

General Discussion : Performing QA – QC for CT Scan

Workshop Nasional AFMI

**DPW AFMI Jawa Tengah
Semarang, 4 – 5 Mei 2017**

General Question??

Procedures and Method?

PURPOSED?

Personel in charge?

Complicated?

How Frequent?

WHAT ?

EQUIPMENTS??

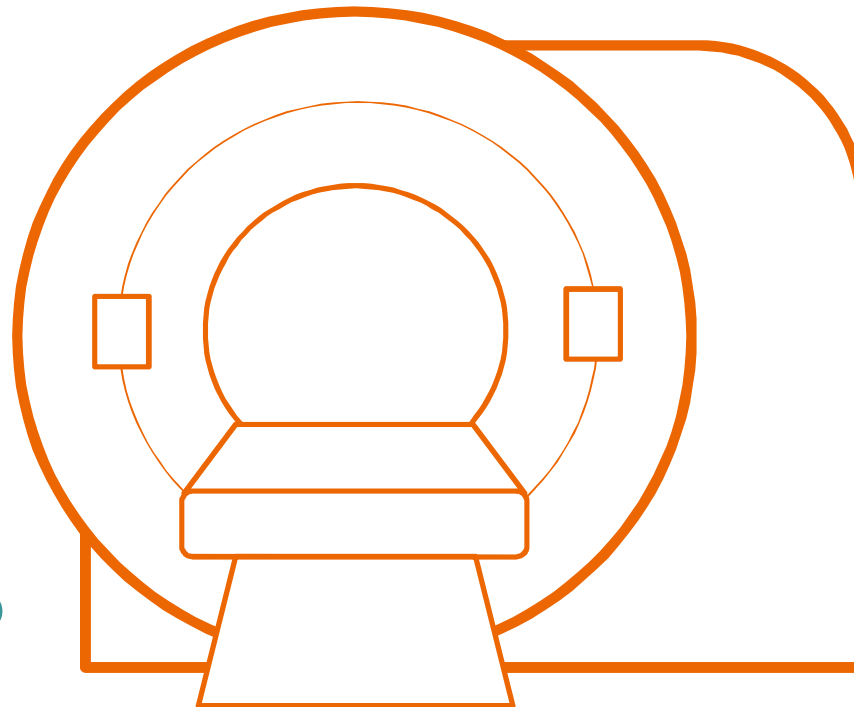

What is QA Procedures?

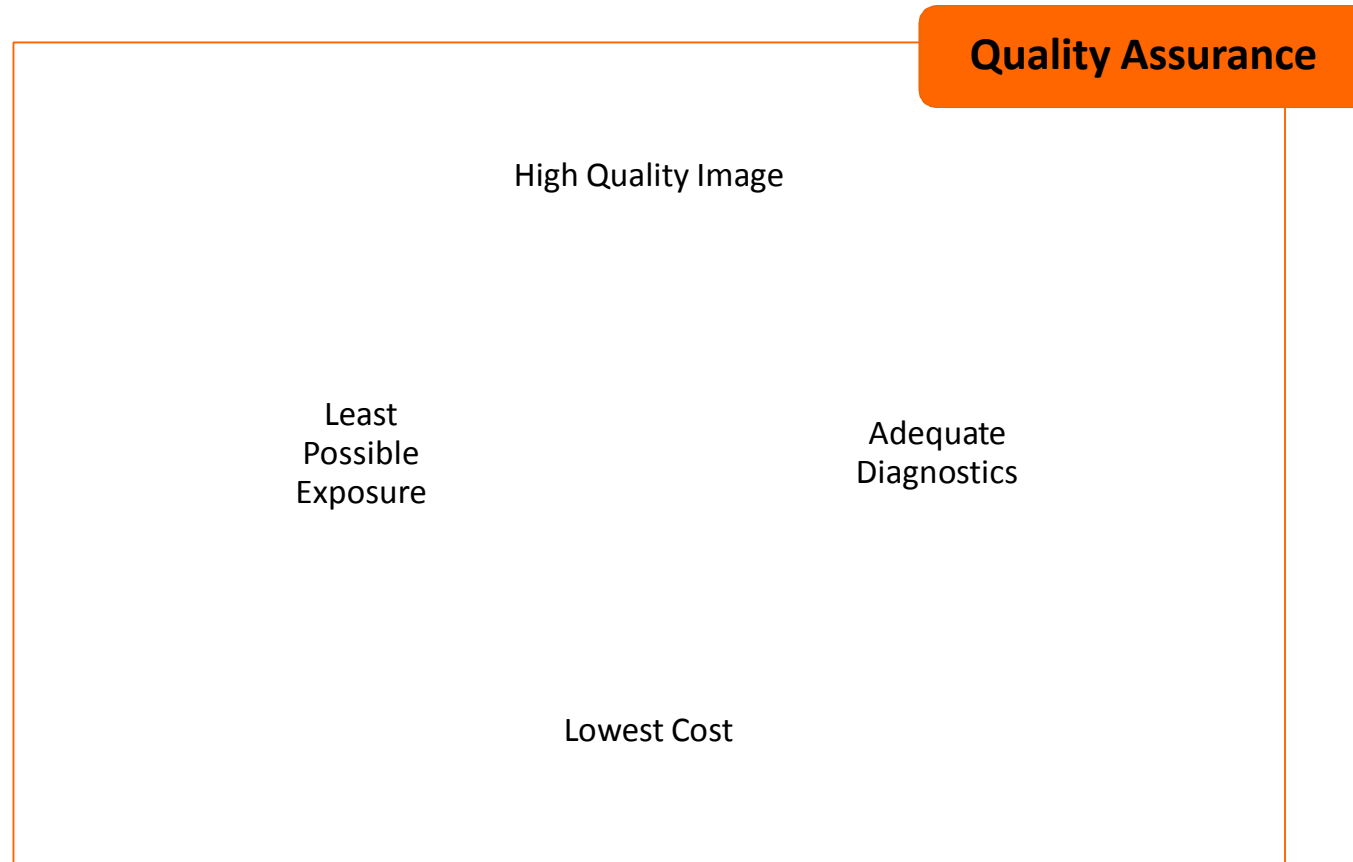

[WORLD HEALTH ORGANIZATION; Quality Assurance in Diagnostic Radiology, WHO, Geneva .1982]

What is QA Procedures?

Quality assurance is a comprehensive concept that comprises all of the oversight and management practices developed by the CT imaging team led by the supervising physician to ensure that :

- 1. Every imaging procedure is necessary and appropriate to the clinical problem at hand**
- 2. The combination of acquisition parameters used for each exam is appropriate to address the clinical question**
- 3. The images generated contain information critical to the solution of that problem**
- 4. The recorded information is correctly interpreted and made available in a timely fashion to the patient's physician**
- 5. The examination results in the lowest possible risk to the patient and is consistent with Objective 2 (above)**

[American College of Radiology ; 2012]

Performance Requirements [IAEA]



What is QC Procedures?

Bagian dari program QA yang meliputi teknik monitoring dan pemeliharaan alat serta sistem radiologi

[Jeffrey Papp; Quality Management in the Imaging Sciences *Fourth Edition*.2013]

QC Procedures [Acceptance, Corrective, Clinical]

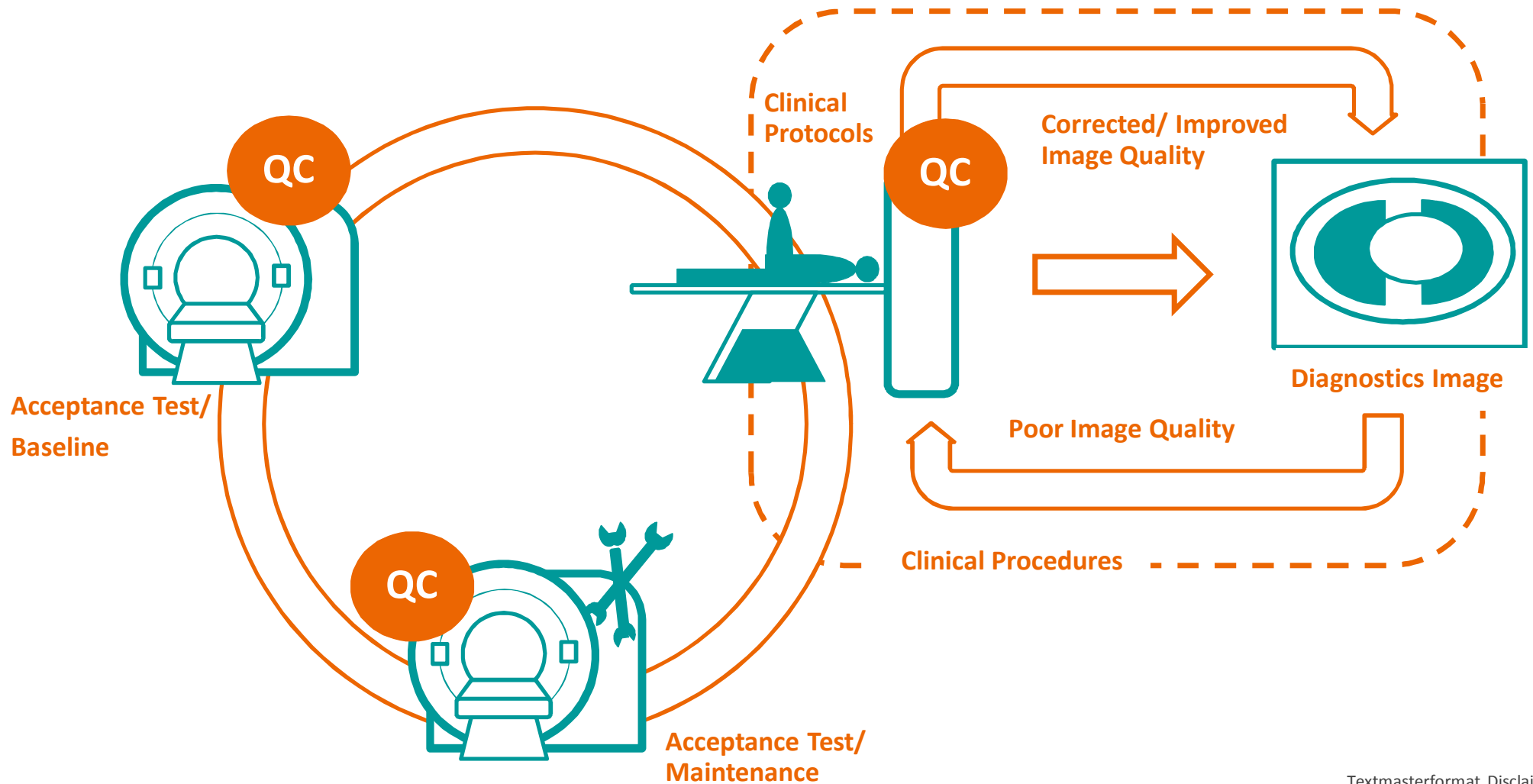

Purposed QC Procedures [Base Line]

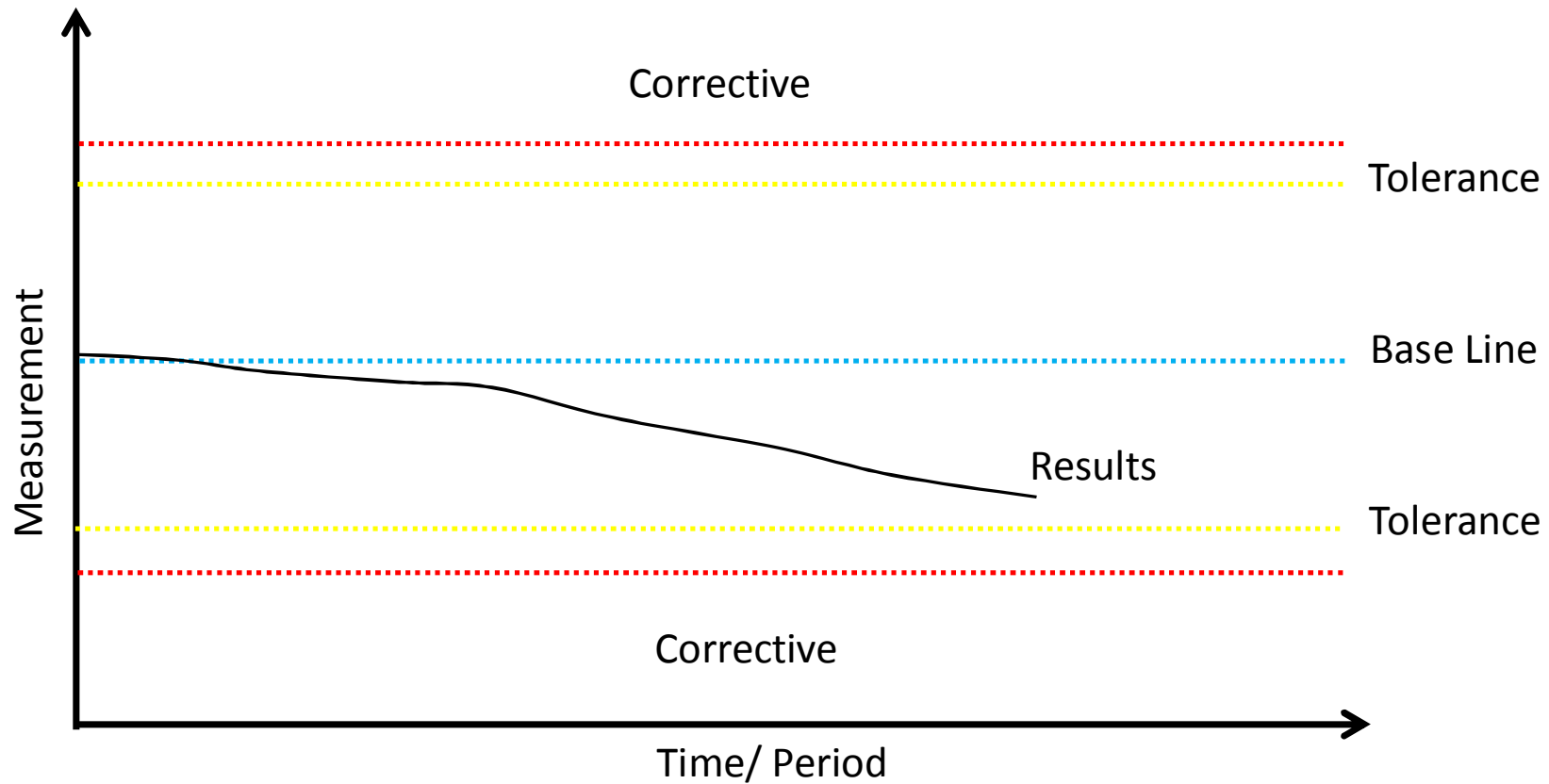

Personel In Charge QA- QC?

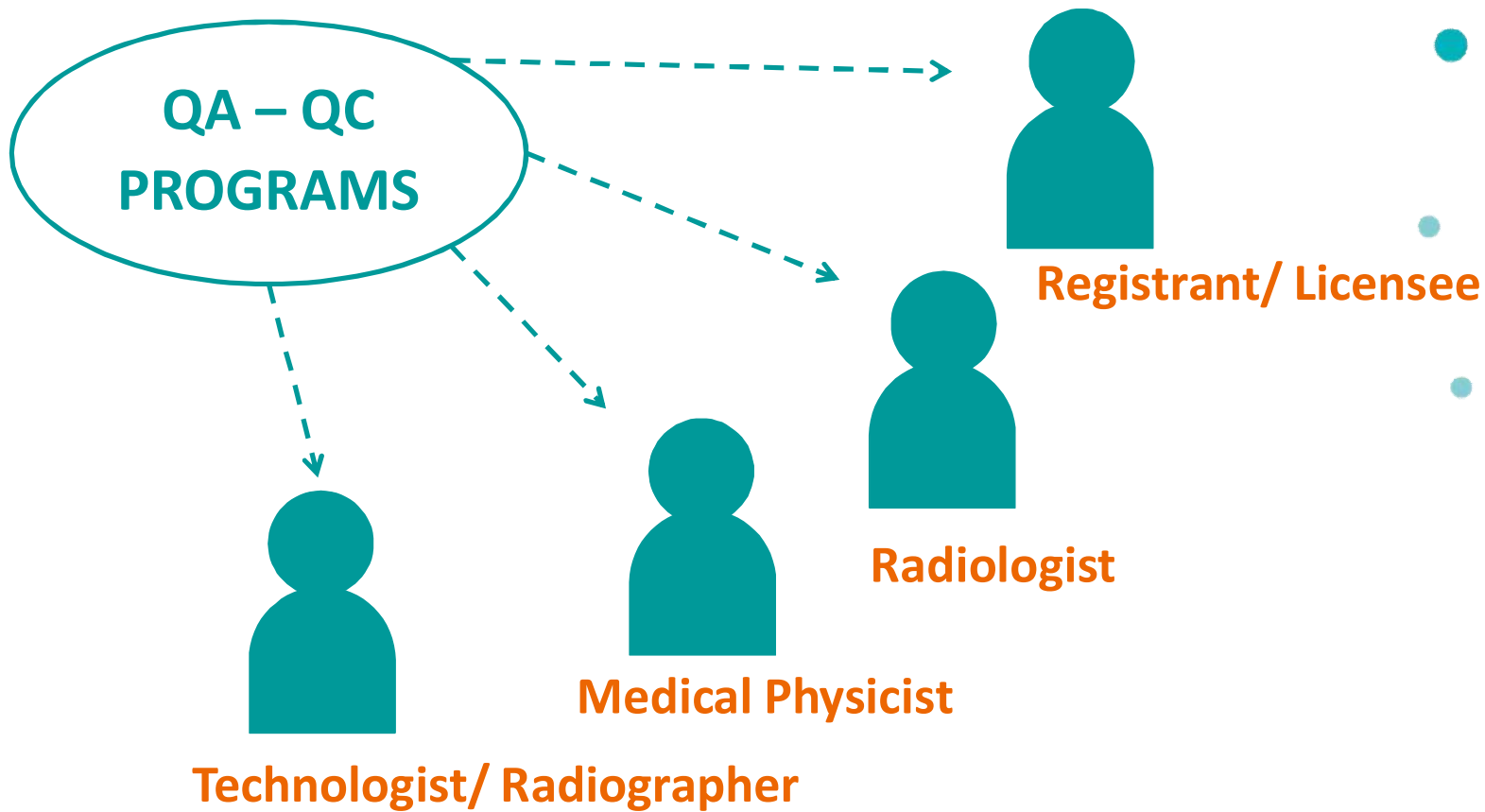

Personel In Charge QA- QC?

REGISTRANT / LICENSEE

- 1. Ensure that all regulatory and/or licensing requirements are met**
- 2. Ensure that all radiologists, radiographers, medical physicists and other personnel who work at the facility are appropriately qualified and trained and meet all continuing education and experience requirements**
- 3. Ensure that a QA programs is in place that encompasses all aspects of the imaging process, it may be delegated into appropriate staff which has qualification and experiences.**

[Quality Assurance Programme for Computed Tomography: Diagnostic and Therapy Applications IAEA]

Personel In Charge QA- QC?

RADIOLOGIST

- 1. Ensuring that medical physicists and radiographers have adequate training and continuous education courses in CT & Ensuring that all equipment is appropriately maintained**
- 2. Motivating, supervising and managing all aspects related to the QA programme in the area of CT**
- 3. Providing an orientation programme for radiographers based on a carefully established procedures manual**
- 4. Designating a single radiographer to be the primary QC radiographer to perform the prescribed QC tests and oversee those that have been delegated to other individuals**

[Quality Assurance Programme for Computed Tomography: Diagnostic and Therapy Applications IAEA]

Personel In Charge QA- QC?

RADIOLOGIST

- 5. Ensuring availability of the equipment and the necessary materials for the implementation of the QC tests**
- 6. Arranging staffing and scheduling so that adequate time is available to carry out the QC tests and to record and interpret the results**
- 7. Ensuring that a medical physicist is available to oversee the equipment related QC programme and to perform the medical physicist's tests**

[Quality Assurance Programme for Computed Tomography: Diagnostic and Therapy Applications IAEA]

Personel In Charge QA- QC?

RADIOLOGIST

- 8. Reviewing the radiographer's test results at least every 3 months, or more frequently if consistency has not yet been achieved, and reviewing the medical physicist's test results annually, or more frequently as needed**
- 9. Designating an individual to oversee the radiation protection programme for employees, patients and other individuals in the surrounding area**
- 10. Ensuring that records of employee qualifications, mammography technique and procedures, infection control procedures, QC, safety and protection are properly maintained and updated in the CT QC procedures manual**
- 11. Providing feedback continually, both positive and negative, to radiographers on image quality and QC procedures**

[Quality Assurance Programme for Computed Tomography: Diagnostic and Therapy Applications IAEA]

Personel In Charge QA- QC?

RADIOGRAPHER

- 1. Ensuring that the appropriate protocol and technique factors are used for the requested examination**
- 2. Ensuring that the QC tests are performed, interpreted and recorded appropriately. This is best achieved when one radiographer assumes overall responsibility for QC matters and is able to train others to assist in QC activities.**
- 3. Recording imaging problems**
- 4. Undertaking additional continuous education courses.**

[Quality Assurance Programme for Computed Tomography: Diagnostic and Therapy Applications IAEA]

Personel In Charge QA- QC?

MEDICAL PHYSICIST

- 1. Advising the facility on CT image quality and on radiation protection of the patient, staff and members of the public**
- 2. Advising the facility on acquisition, installation and shielding for CT**
- 3. Conducting tests to ensure the safety and proper performance of equipment used in CT. These include acceptance, commissioning and routine QC tests**
- 4. Advising the radiologist and radiographer on optimization**
- 5. Providing oversight and advice to the radiographer who carries out the radiographer's component of the QC programme.**

[Quality Assurance Programme for Computed Tomography: Diagnostic and Therapy Applications IAEA]

SIEMENS
Healthineers

Equipments

Quality Control Ct Scan

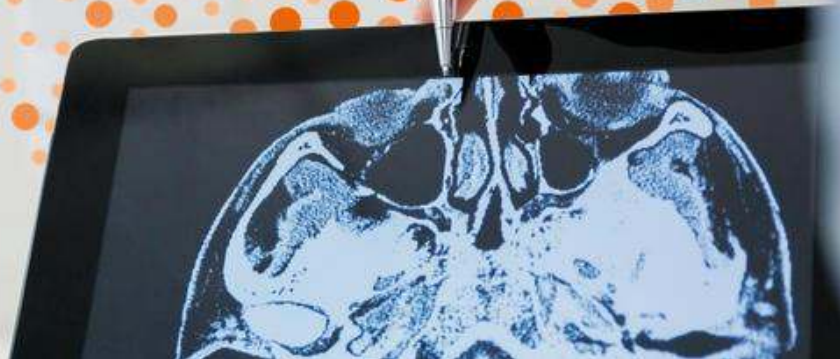

QC Equipments



Alat Ukur Radiasi dan
Phantom Dosimetry

Phantom Image Quality
/ Performance Phantom



Analysis Software

Manufactures Phantom



FDA Recommendations

- Contrast Scale
- Noise
- Tomographic Thickness
- Spatial Resolution (High – Low Contrast)
- CT Number (reference material)

“Siemens” Standard QC Phantom

QC Protocols :

- CT Slice position
- Slice thickness
- CT number homogeneity
- Noise
- Water CT number
- MTF
- Table positioning

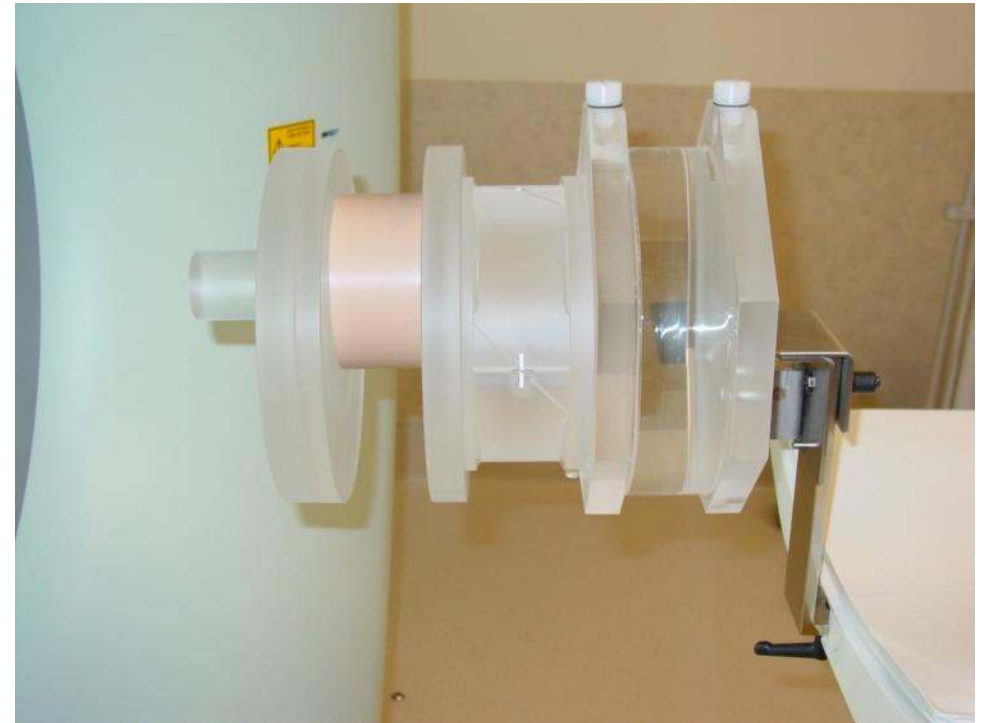

“General Electric” Standard QC Phantom

QC Protocols :

- Slice position
- Slice thickness
- Spatial resolution
- Low contrast
- Noise
- Water CT number

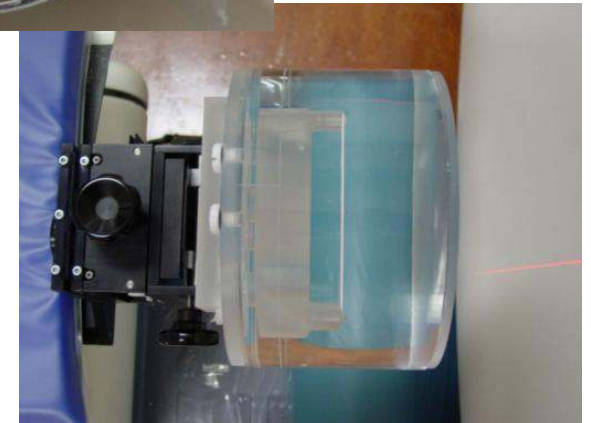
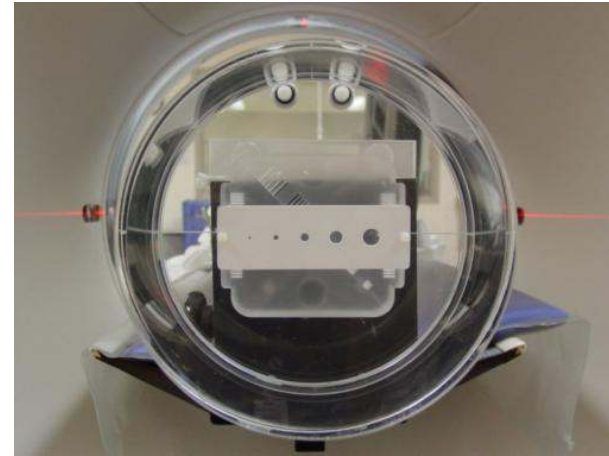

“Philips” Standard QC Phantom

QC Protocols :

- Slice Thickness
- Noise & Uniformity
- “Impulse Response” (MTF)
- Contrast Scale
- Low Contrast Detectability
- Spatial Measurement Accuracy

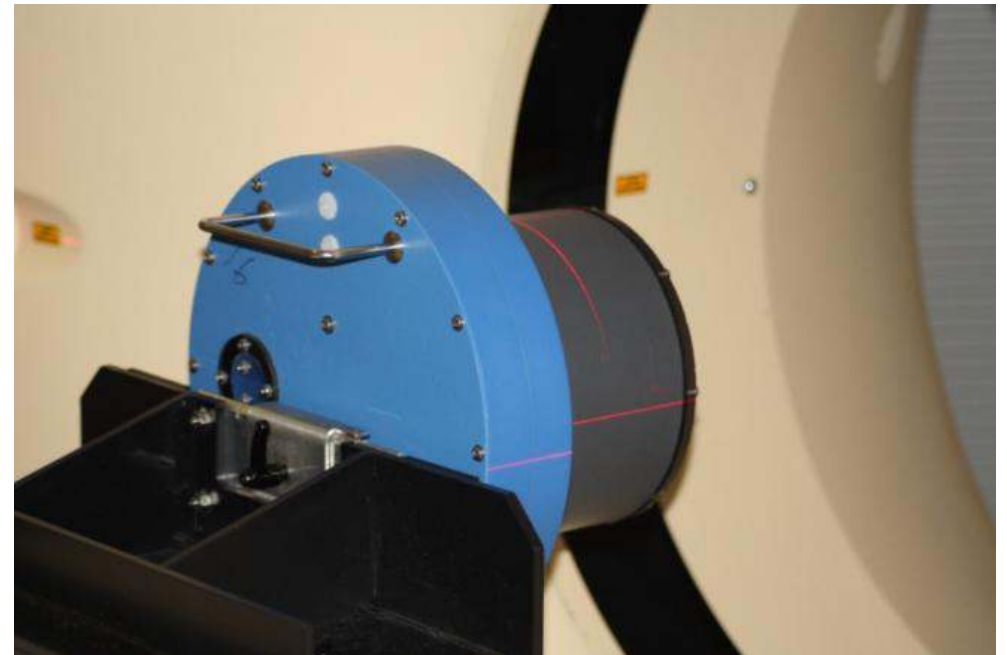

“Toshiba” Standard QC Phantom

QC Protocols :

- Slice Thickness
- Noise & Uniformity
- “Impulse Response” (MTF)
- Contrast Scale
- Low Contrast Detectability
- Spatial Measurement Accuracy



Procedures and Methods

Quality Control CT Scan

ACR Quality Control Manual ; 2012

QA & QC Procedures for Medical Physicist

Daily/ Weekly

- **CT Number Accuracy**
- **Artifact Evaluation**
- **CT Number Uniformity**
- **Image Noise**
- **Visual Inspection**
- **Hard Copy**



Monthly/ Anually

- **Visual Inspection & Clinical Protocols Review**
- **Scout Prescription and Alignment Light Accuracy**
- **Image Thickness – Axial Mode & Sequence Mode**
- **Table Travel Accuracy**
- **Radiation Beam Width**
- **Dosimetry**
- **Hard Copy**
- **Low-Contrast Performance**

Visual Inspection and Review Clinical Protocol

Objectives :

- Ensure that the CT scanner and adjacent areas are safe.
- Ensure that a selection of clinical protocols appropriately utilizes the scanner features
- Ensure that these protocols obtain the diagnostic image quality required

Frequency :

- Acceptance test, Annually or after relevant services

Equipments :

- Visual programs and review check list
- QC Charts and Log
- Written Safety procedures

Visual Inspection and Review Clinical Protocol (Objectives)

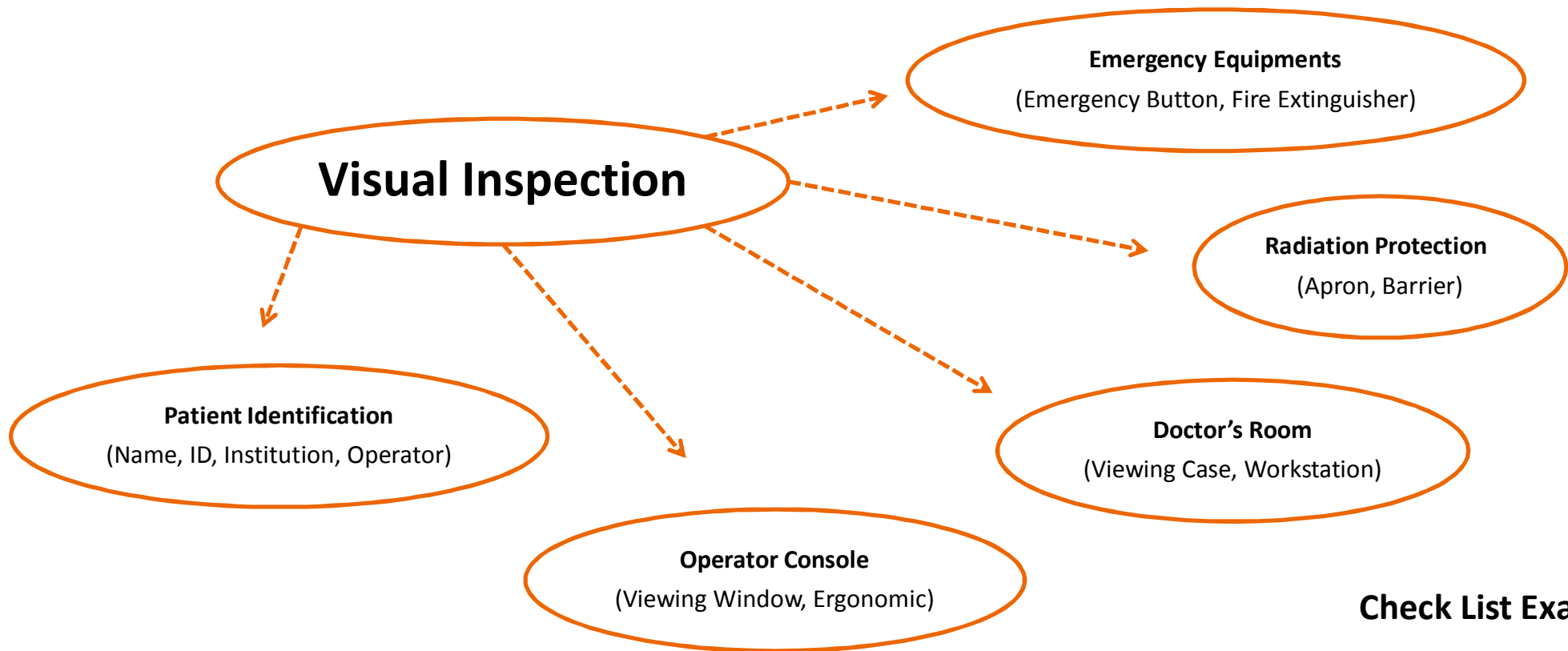

Check List Example

Visual Inspection and Review Clinical Protocol (Objectives)

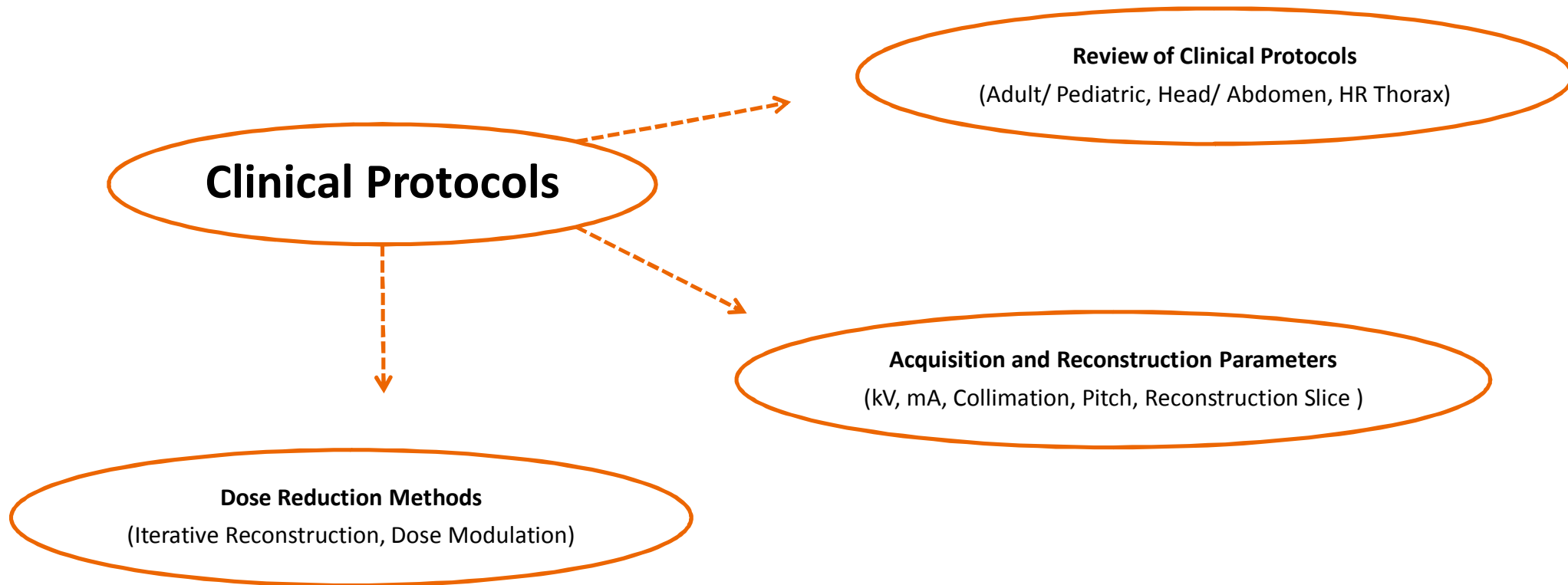

Recommendation Regarding Clinical Protocols [AAPM]

Detector Configuration and Collimation :

- The largest value of detector configuration or beam collimation available for the scan should be used whenever practical, as this improves dose efficiency.

Acquisition and Reconstruction Factors :

- Lower kV settings should be considered for pediatric scans as well as those scans that use intravenous or oral contrast.
- High-Resolution Chest (HRC) protocol should incorporate a sharp reconstruction kernel or filter.

Clinical Dose :

- Doses should be as low as necessary to accomplish the diagnostic task.
- Develop radiation dose thresholds during any new CT protocol design.

Scout and Alignment Light Accuracy

Objectives :

- To verify that the incorporated alignment lights correctly indicate the scan position and that the scout image prescription correctly identifies the scan position

Frequency :

- Acceptance test, Annually or after relevant services

Equipments :

- Phantom that incorporates externally visible radiopaque fiducial markers or an image-center indication

Criteria (IAEA) :

- Acceptable $\pm 5\text{mm}$, Achievable $\pm 1\text{ mm}$ (Beam Alignment)
- Acceptable $\pm 2\text{mm}$, Achievable $\pm 1\text{ mm}$ (Scout Accuracy)

Scout and Alignment Light Accuracy

Test Procedure : (Beam Alignment)

- Using the alignment lights, carefully position the phantom to the radiopaque markers/ Image center Indication in all 3 orthogonal planes.
- Zero the table location indication.
- Scan the phantom in axial mode using a reconstructed scan width less than 2 mm or as thin as the scanner can produce in axial mode at the zero position.
- Use a technique appropriate to the phantom to allow accurate visualization of the fiducial markers; for most phantoms, the adult abdomen technique works well.

Scout and Alignment Light Accuracy

Test Procedure : (Light Accuracy)

- Scan the entire phantom in scout mode.
- Magnify the image, if possible, and position a single slice at the location of the radiopaque fiducial markers.
- Perform an axial scan using a reconstructed scan width less than 2 mm or as thin as the scanner can produce in axial mode.

Scout and Alignment Light Accuracy

Analysis : (Light Accuracy)

- Scan the entire phantom in scout mode.
- Magnify the image, if possible, and position a single slice at the location of the radiopaque fiducial markers.
- Perform an axial scan using a reconstructed scan width less than 2 mm or as thin as the scanner can produce in axial mode.

Image Thickness

Objectives :

- To ensure that the reconstructed imaged slice width is similar to that selected on the CT scanner console

Frequency :

- Acceptance test, Annually or after relevant services

Equipments :

- A phantom with internal targets that allow the determination of reconstructed image thickness

Criteria (IAEA) :

Nominal Slice (mm)	Acceptable
≤ 1 mm	$< \text{nominal} + 0.5$ mm
>1 mm and ≤ 2 mm	$\pm 50\%$
>2 mm	± 1 mm

Image Thickness

Test Procedures : (Sequence Mode)

- Align the axial z sensitivity test device so that its axis coincides with the axis of rotation of the CT scanner with the image centred in the FOV.
- Perform an SPR to confirm acceptable alignment and to define the tomographic plane.
- Select a scan protocol.
- Scan the test object as required.
- Repeat for all other selected scan protocols.

Image Thickness

Test Procedures : (Helical Mode)

- Place the helical z sensitivity test object on the CT couch or secure it on a stand so that it is centred in the FOV and aligned such that the metal foil insert is parallel to the tomographic plane.
- Perform an SPR and define the scanned volume for helical scanning to ensure the metal foil is fully imaged.
- Select a scan protocol.
- Scan the test object.
- Reconstruct images at intervals of approximately one tenth of the nominal imaged slice width.

Image Thickness

Data Analysis :

- Place an ROI over the central portion of each reconstructed image corresponding to the position of the metal disc insert and measure the average CT number in it.
- Plot the measured values of the CT number versus image position (distance in the z axis direction) in chart.
- Determine CTmax and CTb.
- Determine the FWHM by calculating the distance between the two points corresponding to the CThalf values.
- Simple linear interpolation may be used to obtain this distance more accurately. This distance represents the imaged slice width .

$$CT_{half} = \frac{(CT_{Max} - CT_b)}{2} + CT_b$$

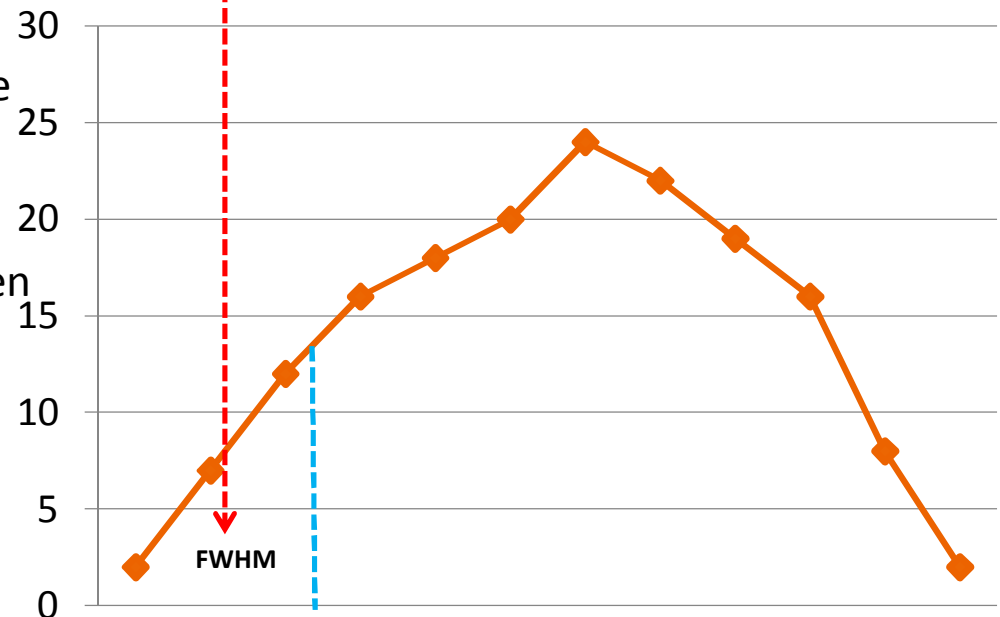
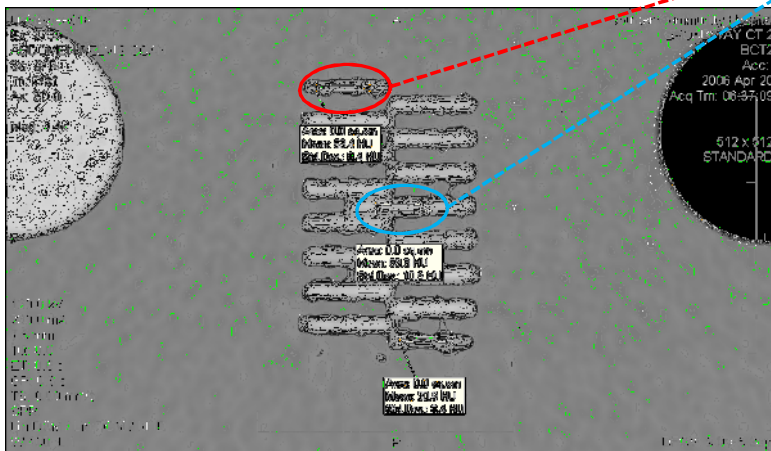
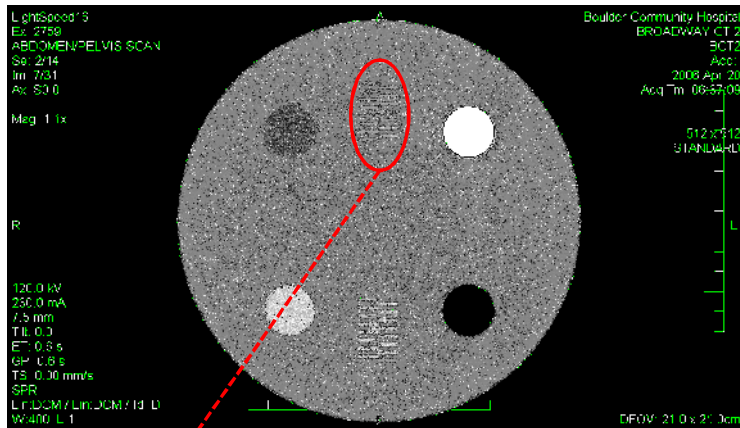

Image Thickness



$$CT_{half} = \frac{(CT_{Max} - CT_b)}{2} + CT_b$$

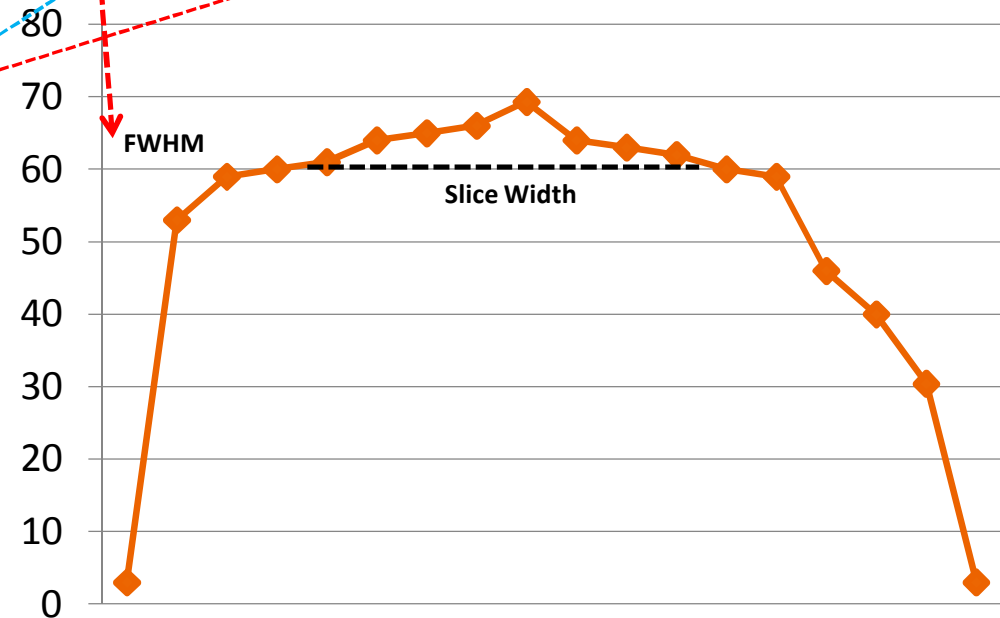

Table Travel Accuracy

Objectives :

- To verify that the patient table translates as indicated

Frequency :

- Acceptance test, Annually or after relevant services

Equipments :

- A phantom with 2 sets of external fiducial markers of known separation

Criteria (IAEA) :

- The table translation accuracy and return to a fixed position should be accurate to within 2 mm

Table Travel Accuracy

Test Procedures :

- If possible, add weight to the tabletop to simulate the weight of an average patient.
- Using the alignment light, carefully position the phantom such that the first set of fiducial markers is in the axial plane.
- Zero the table position indication.
- Move the table to the second set of external fiducial markers.
- Record the table position.
- Translate the table to full extension and return to the first set of fiducial markers.
- Record the new table position.

Table Travel Accuracy

Data Analysis :

- Compare the distance between the fiducial markers as determined by the table travel to the known distance.
- Compare the first fiducial marker table position to the new position recorded after the table extension and return.

Criteria (IAEA) :

- The table translation accuracy and return to a fixed position should be accurate to within 2 mm

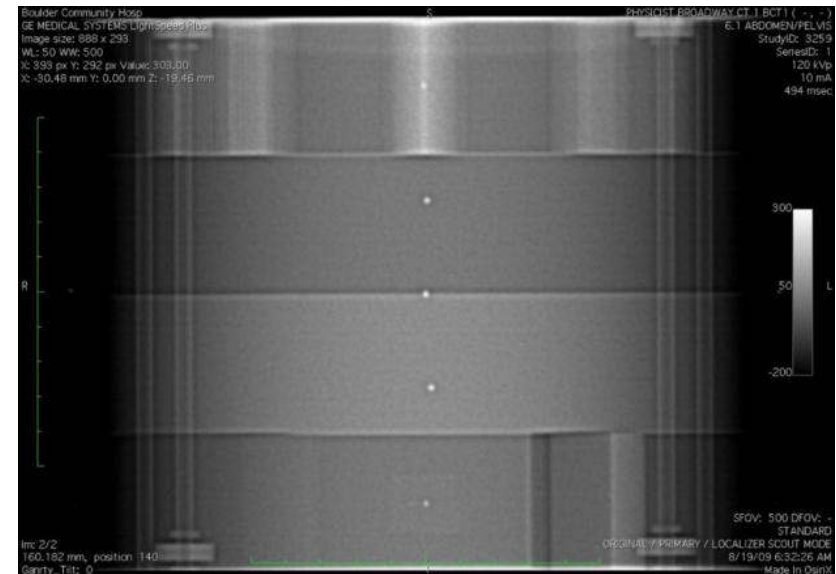

Radiation Beam Width

Objectives :

- To measure the radiation beam width and to assess its relationship to the nominal collimated beam width
- To determine the extent of over-beaming

Frequency :

- Acceptance test, Commissioning, Annually or after relevant services

Equipments :

- External radiation detector (CR Plate, Gafchromic Film, TLD array)
- Attenuator Plate

Criteria (IAEA) :

- Within 3mm or 30% of Applied Collimator

Radiation Beam Width

Test Procedures :

- Place film on a flat foam block to minimize scatter on the film.
- Raise the couch so that the film surface is on the isocentre of the scanner.
- Mark the isocentre of the film.
- Scan the film in axial mode for one collimation setting using a set kV and mAs as required to give the film a density that is clearly below the film maximum density.
- Repeat for all other selected scan protocols.

Radiation Beam Width

Data Analysis :

- Plot the profile of the density of the exposed film using a film scanning device
- Defines the FWHM value for the film, apply the density value for the FWHM to each of the beams plotted to determine the X ray beam width.

Radiation Beam Width

Criteria (IAEA) :

- Within 3mm or 30% of Applied Collimator

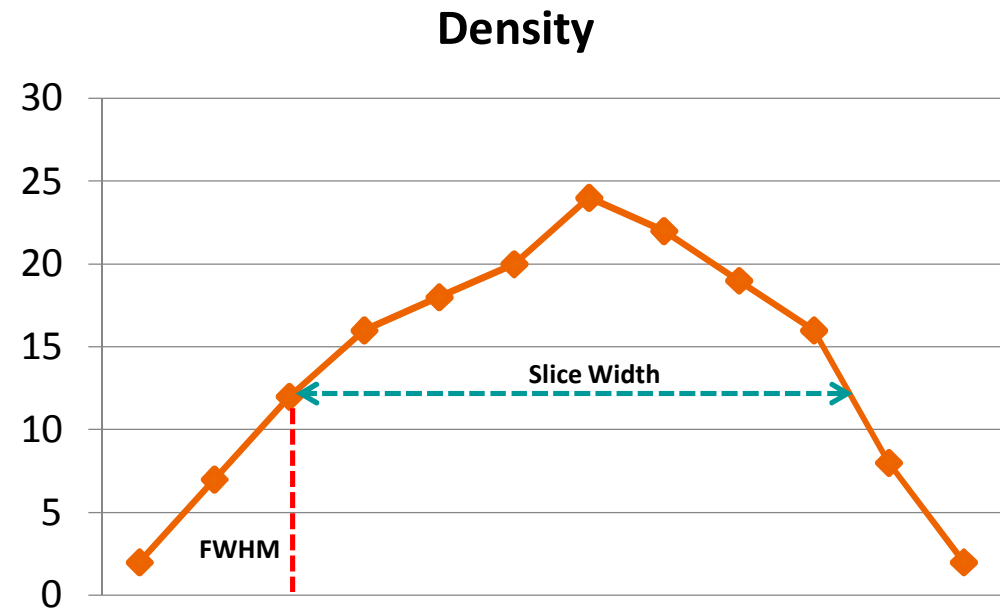
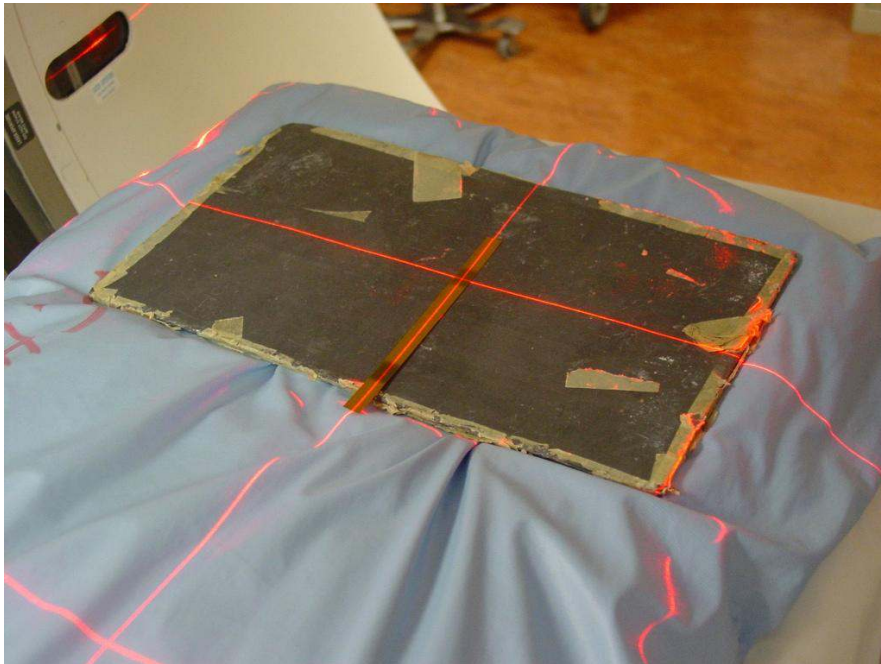

Low Contrast Performance

Objectives :

- To verify that the low-contrast performance of clinical protocols is adequate for diagnosis

Frequency :

- Acceptance test, Annually or after relevant services

Equipments :

- A phantom that incorporates low-contrast targets of known contrast

Low Contrast Performance

Test Procedures :

- Align the phantom.
- Perform clinical scans covering the low-contrast section of the phantom (No Dose Modulation).
- At a minimum, the scans performed should include the following:
 - Adult head (average)
 - Pediatric head (1 year old)
 - Adult abdomen (70 kg)
 - Pediatric abdomen (5 years old; 40-50 lb, approx. 20 kg)

Low Contrast Performance

Data Analysis : (Visual Analysis)

- View each series and determine the image that provides the best low-contrast performance.
- Adjust the window width/level to optimize visibility of the low-contrast targets.
- Record the size and/or contrast of the barely visualized target.

Low Contrast Performance

Data Analysis : (Numeric Analysis)

- View each series and determine the image that provides the best low-contrast performance .
- Place ROI to measure HU number of the target material and structure adjacent the target
- Calculate CNR from largest representative target and adjacent background

Low Contrast Performance

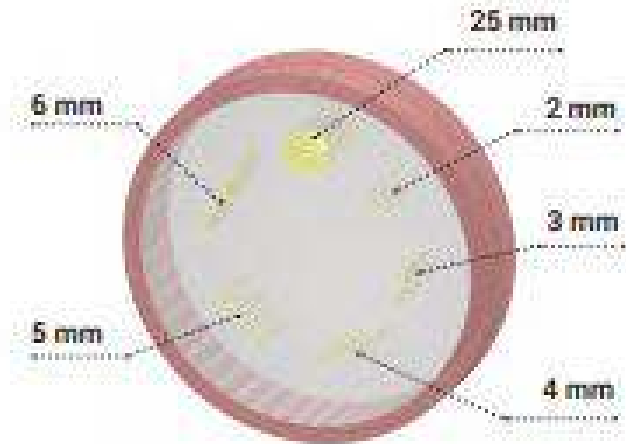

Criteria :

Scan protocol	CNR
Adult Head	1.0
Pediatric Head	1.0
Adult Abdomen	1.0
Pediatric Abdomen	0.5

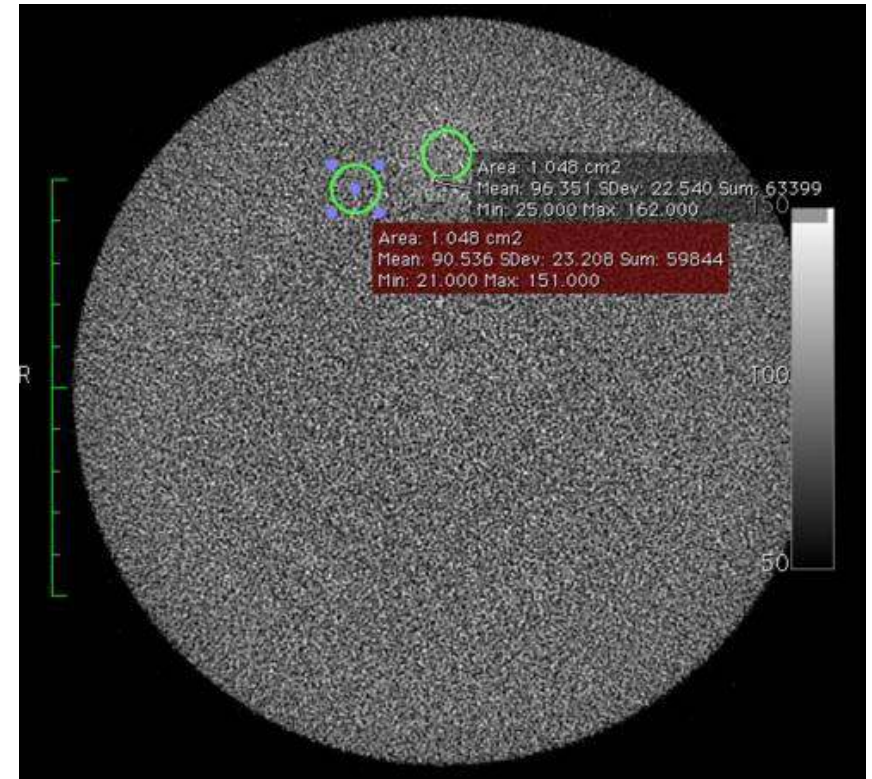

$$CNR = \frac{(T_{mean} - BG_{mean})}{BG_{stdev}}$$

Spatial Resolution

Objectives :

- To ensure that the spatial resolution of a reconstructed image complies with manufacture standards.

Frequency :

- Acceptance test, Annually or after relevant services

Equipments :

- A phantom that incorporates with spatial resolution either for visual analysis or MTF analysis

Spatial Resolution

Test Procedures :

- Align the phantom.
- Perform clinical scans covering the low-contrast section of the phantom (No Dose Modulation).
- At a minimum, the scans performed should include the following:
 - Adult abdomen (average)
 - High Resolution Chest

Spatial Resolution

Data Analysis : (Visual Analysis)

- View each series and determine the image that provides the best high-contrast target.
- Adjust the window width/level to optimize visibility of the low-contrast targets.
- Determine and record the highest frequency visible in the image.

Data Analysis : (Software Analysis)

- Use proper software (some may provide by CT Manufacture) to create MTF for determine spatial resolution

Spatial Resolution

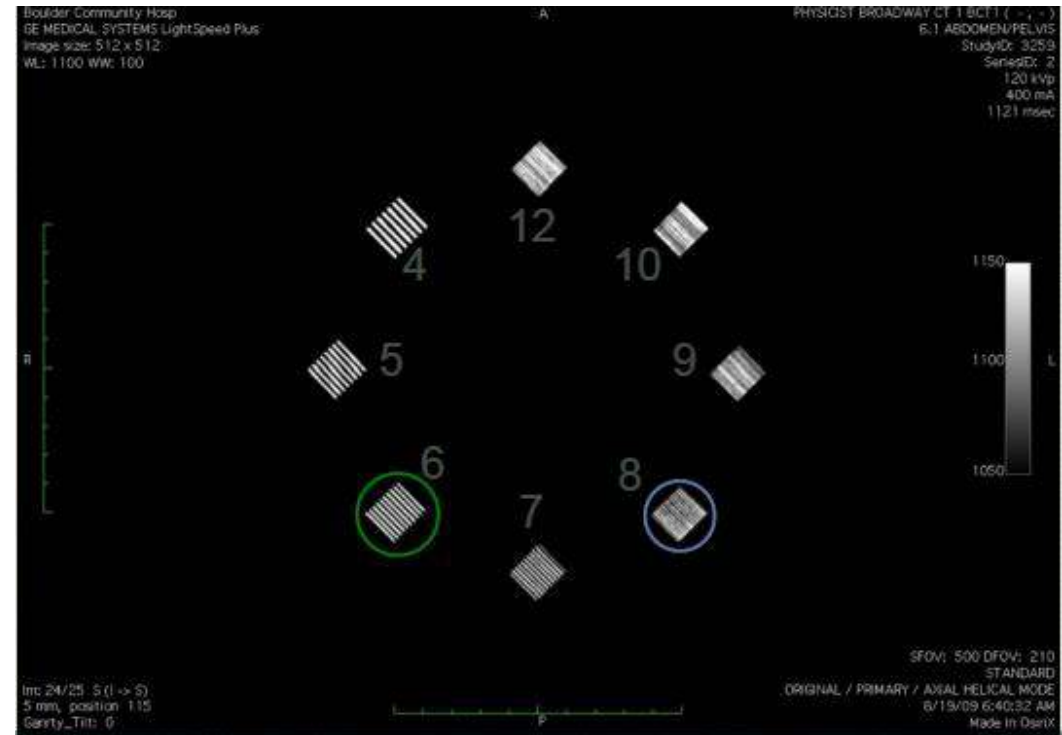
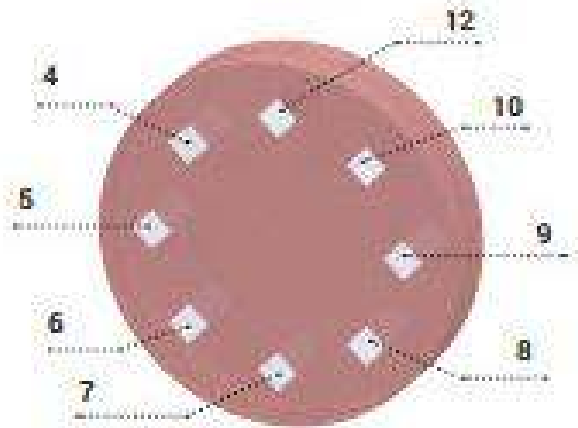

Criteria (IAEA) :

- Within manufacture criteria

Scan protocol	Limiting Resolution
Adult Abdomen	6 lp/cm
High-Resolution Chest	8 lp/cm

CT Number Accuracy, Artifacts, Noise and Uniformity

Objectives :

- To verify that the CT numbers reported by the CT scanner are acceptably accurate and vary as expected.

Frequency :

- Acceptance test, Annually or after relevant services

Equipments :

- A phantom that incorporates targets that provide different known CT number values.
- Phantom provide by manufacture for co-responding test

CT Number Accuracy, Artifacts, Noise and Uniformity

Test Procedures :

- Align the phantom.
- Perform clinical scans covering the low-contrast section of the phantom (No Dose Modulation).
- If possible, the scans performed should include the following:
 - Adult Head
 - Pediatric Head
 - Adult abdomen (average)
 - Pediatric Abdomen

CT Number Accuracy, Artifacts, Noise and Uniformity

Data Analysis : (CT Number Accuracy)

- Select the image most central to the module containing the CT number accuracy targets.
- Adjust the window width/level to optimize visibility of the targets.
- Place a circular ROI, approximately 80% of the size of the target, in each target.
- Record the measured CT number mean for each target

CT Number Accuracy, Artifacts, Noise and Uniformity

CT ACR 464 Phantom modules

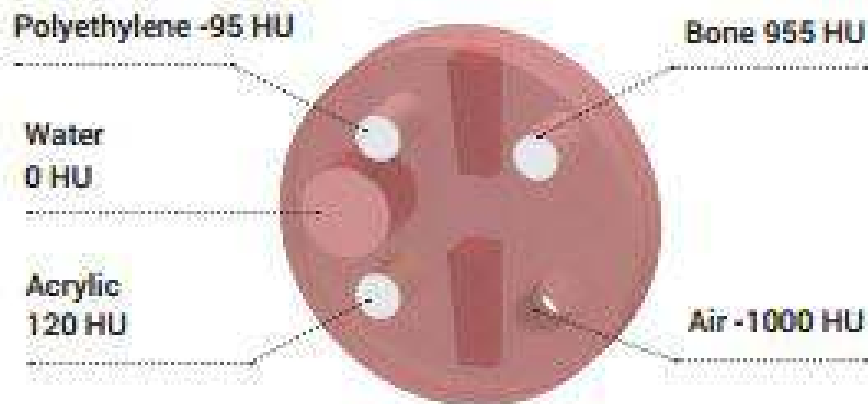

Criteria [IAEA] :

- Acceptable ± 5 from baseline value, achievable ± 4 (water)
- Acceptable ± 10 from baseline value (material)

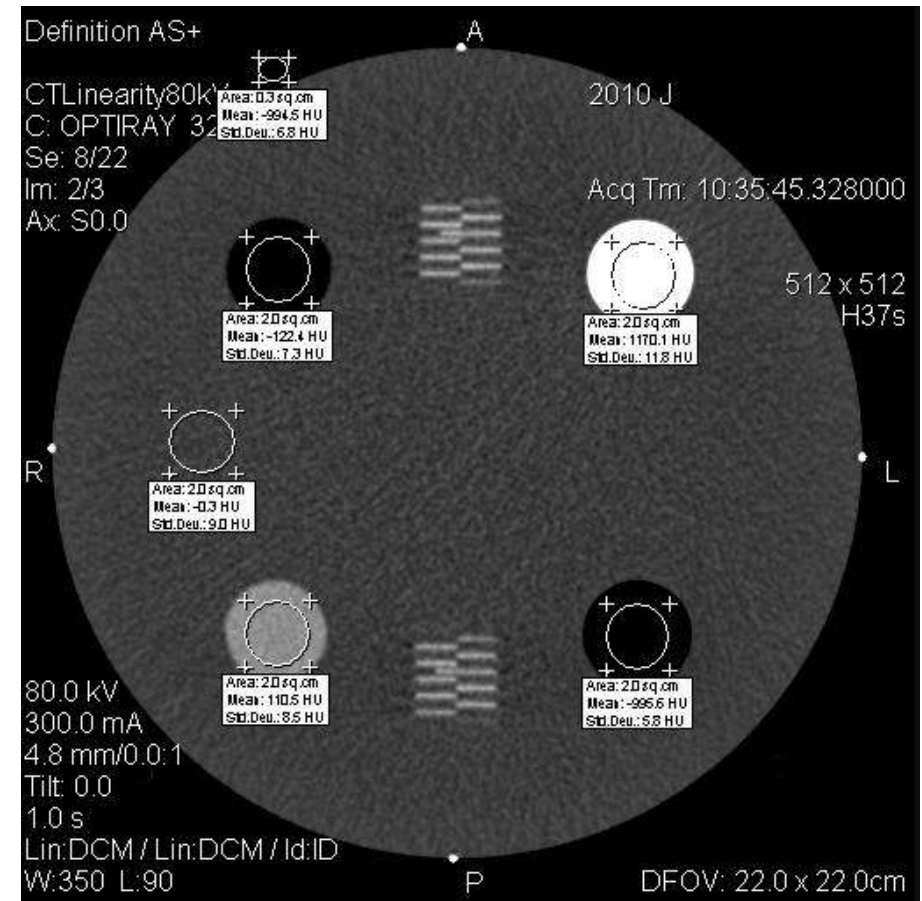

CT Number Accuracy, Artifacts, Noise and Uniformity

Data Analysis : (Noise and Uniformity)

- Select image of water phantom (homogen, no air inside).
- Adjust the window width/level to optimize visibility of the targets.
- Place a circular ROI, at least in 5 position inside the phantom which represent central and peripheral area of the phantom.
- Record the measured CT number mean for each target ROI

Criteria :

Test Type	Acceptable	Achievable
Image noise	±25% of the baseline	±10% of the baseline
Uniformity	±10	±4

CT Number Accuracy, Artifacts, Noise and Uniformity

Data Analysis : (Artifacts)

- Select image of water phantom (homogen, no air inside).
- Adjust the window width/level to optimize visibility of the targets.
- Visual interpretation of image to evaluate a possible artifacts shown

Criteria :

- No visual artefacts shown in the image

CT Number Accuracy, Artifacts, Noise and Uniformity

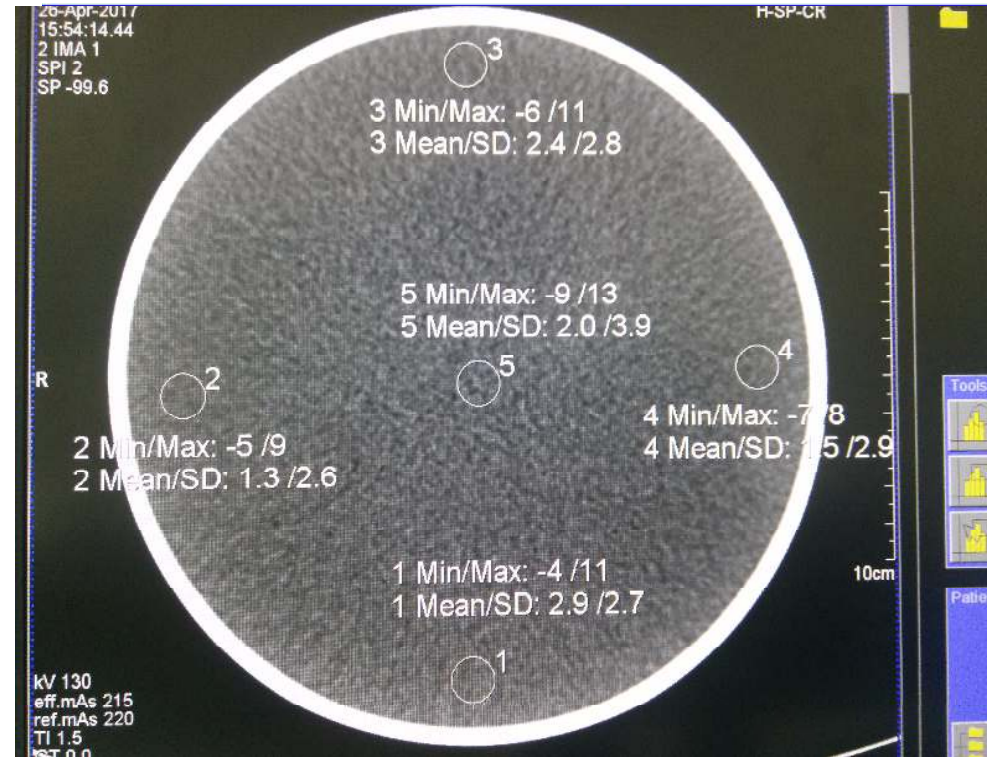
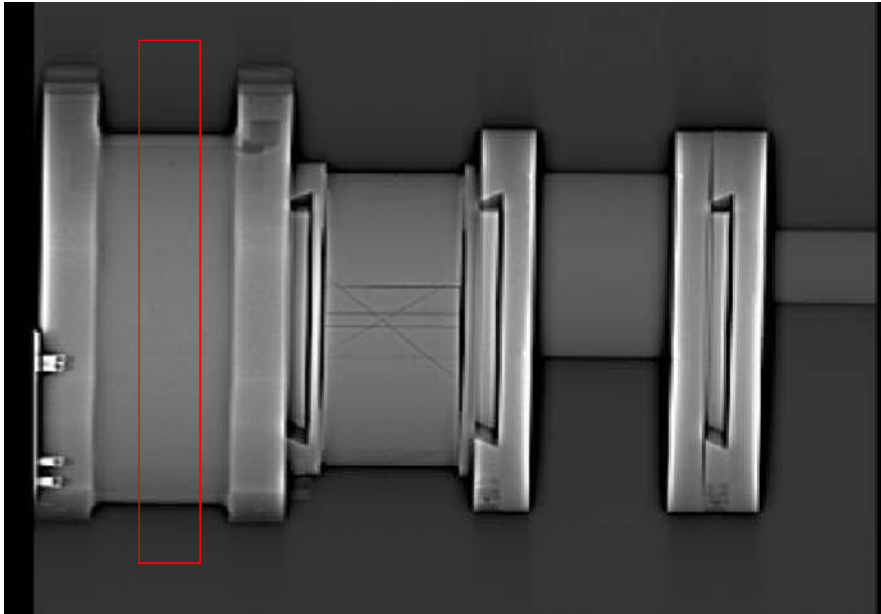

Criteria [IAEA] :

- No Artifacts shown in the image

Test Type	Acceptable	Achievable
Image noise	±25% of the baseline	±10% of the baseline
Uniformity	±10	±4

Objectives :

- To measure doses for verification of scanner performance and to allow for calculation of dosimetric quantities relevant to patient exam estimates.

Frequency :

- Acceptance test, Annually or after relevant services

Equipments :

- Calibrated electrometer and CTDI pencil ionization chamber (10- or 15-cm long)
- 16-cm (head) CTDI dosimetry phantom
- 32-cm (adult body) CTDI dosimetry phantom

Dosimetry

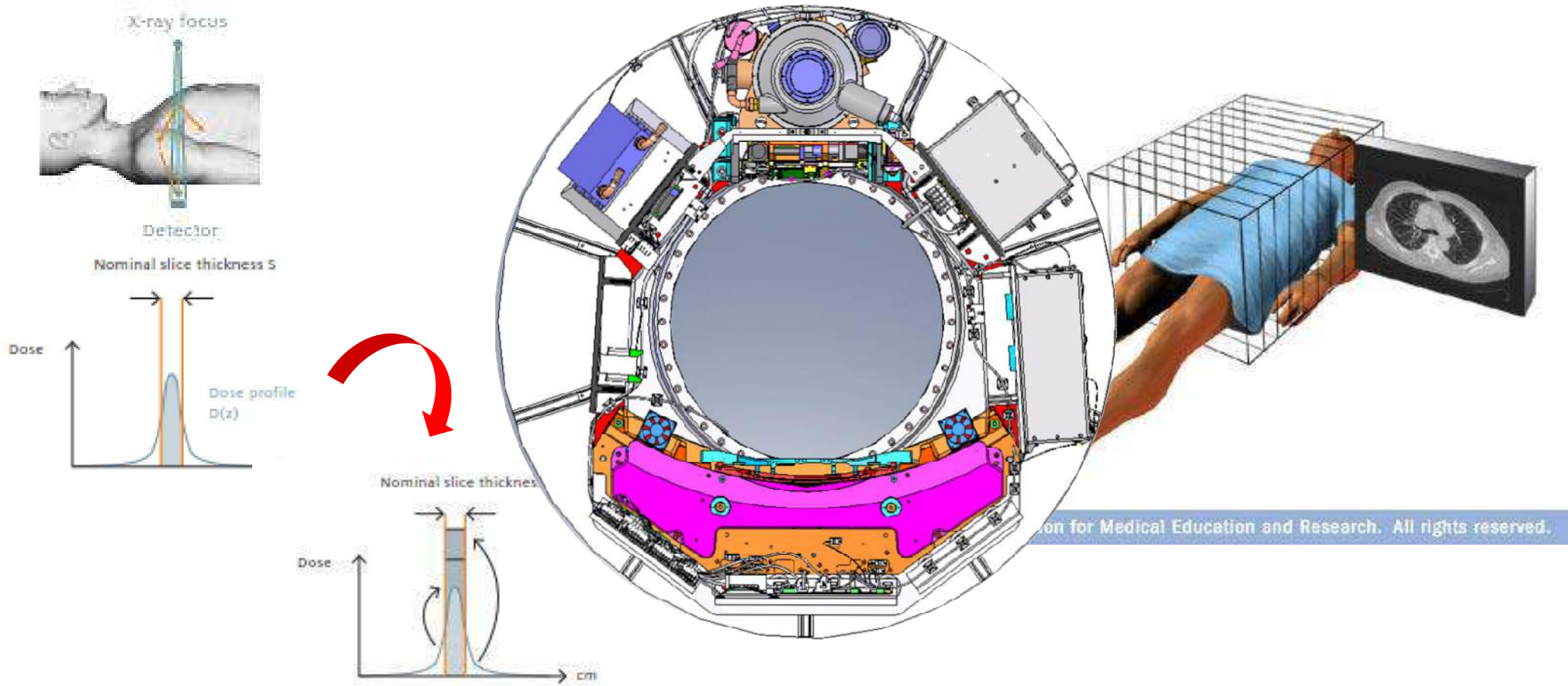

on for Medical Education and Research. All rights reserved.

CTDI_w dan CTDI_{vol}

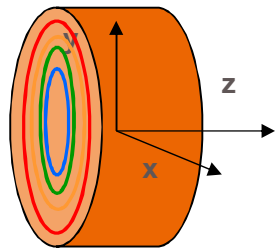

$$CTDI_w = \frac{2}{3} \cdot CTDI_{100}^{Peripheral} + \frac{1}{3} \cdot CTDI_{100}^{central}$$

Multi Slice/ VolumetricScan

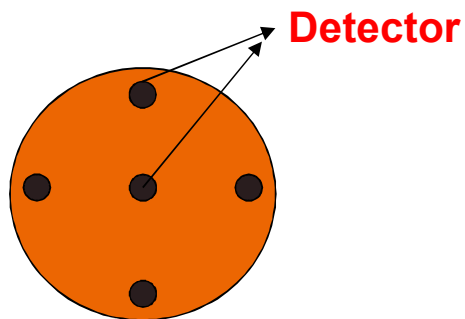

$$CTDI_{vol} = \frac{CTDI_w}{\left(\frac{\text{feed per scan}}{\text{total collimation}} \right)}$$

$$CTDI_{vol} = \frac{CTDI_w}{\text{pitch}}$$

$$DLP = CTDI_{vol} \cdot L \text{ [mGy cm]}$$

L = Scan length

Dosimetry

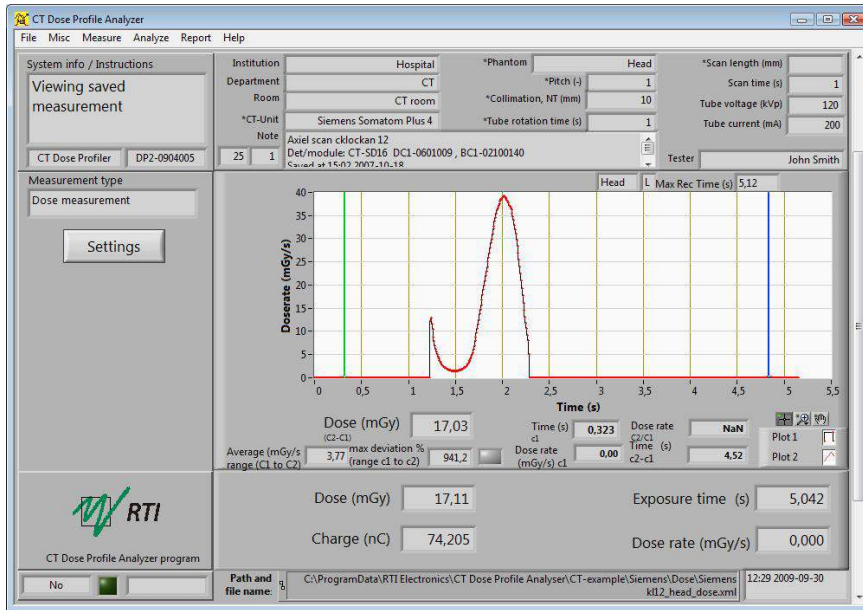

Criteria :

- Dose Calculation in Air : Output at every kVp $\pm 5\%$ from baseline
- CTDIvol for clinical protocols : Less than Dose Reference Level
- Verify scanner CTDIvol : $\pm 10\%$

Thanks all

For Your Kind

Attention

Semarang, 4 – 5 May 2017