

General Purpose Toroidal Conductivity Sensors

- NON-CONTACTING (TOROIDAL) SENSORS resist corrosion and fouling.
- SENSORS ARE IDEAL for measuring concentrations of acid, base, and salt solutions.
- A VARIETY OF MOUNTING CONFIGURATIONS ARE AVAILABLE: submersion, insertion, and retractable.

APPLICATIONS

Rosemount Analytical toroidal conductivity sensors are ideal for use in corrosive liquids or in liquids containing high levels of suspended solids that would otherwise corrode or foul metal-electrode sensors. Toroidal conductivity sensors are also well-suited for measuring highly conductive electrolyte solutions.

FEATURES

The Model 226 and 228 toroidal (inductive) conductivity sensors consist of a pair of wire-wound metal toroids overmolded with either corrosion-resistant PEEK or Tefzel^{®1}. When the sensor is immersed in a conductive liquid and an AC voltage is applied to the drive coil, a voltage is induced in the liquid surrounding the coil. The voltage causes an ionic current to flow proportional to the conductance of the liquid. The ionic current induces a current in the receive coil, which the analyzer measures. The induced current is directly proportional to the conductivity of the solution.

Toroidal sensors work well in highly conductive liquids, up to about 2 S/cm (2,000,000 uS/cm). Performance in low conductivity samples is somewhat limited, with the minimum conductivity depending on the dimensions of the toroids, the number of windings in each, and the analyzer. When used with the Model 1056 and 56 analyzer the limits are 15 uS/cm for the 228 sensor and 5 uS/cm for the 226 sensor. When used with other instruments, the limits are 200 uS/cm for the 228 sensor, and 50 uS/cm for the 226 sensor.

The measurement is insensitive to flow rate and direction. The sensor must be installed so that it is completely flooded, and the toroid hole must remain open.

The Model 226 and 228 sensors have integral RTDs to allow temperature-compensated conductivity measurements.

An insertion/retraction assembly is available for the Model 228.

¹Tefzel is a registered trademark of E.I. duPont de Nemours and Co.



MODEL 226



MODEL 228



MODEL 228
with
retraction
assemblies

MODEL 226 SUBMERSION/INSERTION SENSOR

The Model 226 is a rugged, large bore sensor molded in glass-filled PEEK (polyetheretherketone). A metal frame supports the toroids and reinforces the mounting shaft, so the sensor can readily withstand harsh conditions. The large bore means the sensor resists plugging, so the sensor is ideal for liquids containing high levels of suspended solids that would tend to plug the smaller opening in the 228 sensor. The large toroids in the 226 sensor allow it to measure lower conductivities than the 228 sensor.

MODEL 228 SUBMERSION/INSERTION SENSOR

The Model 228 has rugged construction similar to the 226 sensor. A metal frame supports the toroids and reinforces the mounting shaft, so the sensor tolerates

high vibration applications such as drilling mud shaker trays. The metal frame and toroids are overmolded with either PEEK (glass-filled) or Tefzel (glass-filled or unfilled). There are no seams or welds to crack and cause leakage and failure.

RETRACTION ASSEMBLIES FOR THE MODEL 228 SENSOR

The retraction assembly allows the 228 sensor to be removed from piping and tanks without shutting down and draining equipment. Manual and mechanical retraction assemblies are available. Each requires a 1-1/2 inch full port ball valve, which must be ordered separately. Two wash ports in the retraction chamber allow the sensor to be washed clean of corrosive liquids before it is removed.

SPECIFICATIONS (Model 226)

Conductivity range:

analyzer	minimum	maximum
1056 and 56	5 uS/cm	500 mS/cm
all others	50 uS/cm	1000 mS/cm

Process connection:

option	connection
-80	1-inch MNPT
-81	7/8-inch 9 UNC

Wetted Materials: Glass-filled PEEK

Temperature: 248°F (120°C) maximum

Pressure: 295 psig (2135 kPa abs)

Cable length: 20 ft (6.1 m)

Maximum cable length: 200 ft (61 m)

Installation: Install the sensor so that it is completely immersed in the process liquid. Mounting in a vertical pipe run is best. If the sensor must be installed in a horizontal pipe run, place the sensor in the 3 o'clock position.

Weight/shipping weight: 2 lb/3 lb (1.0 kg/1.5 kg)
(rounded up to nearest 1 lb or 0.5 kg)

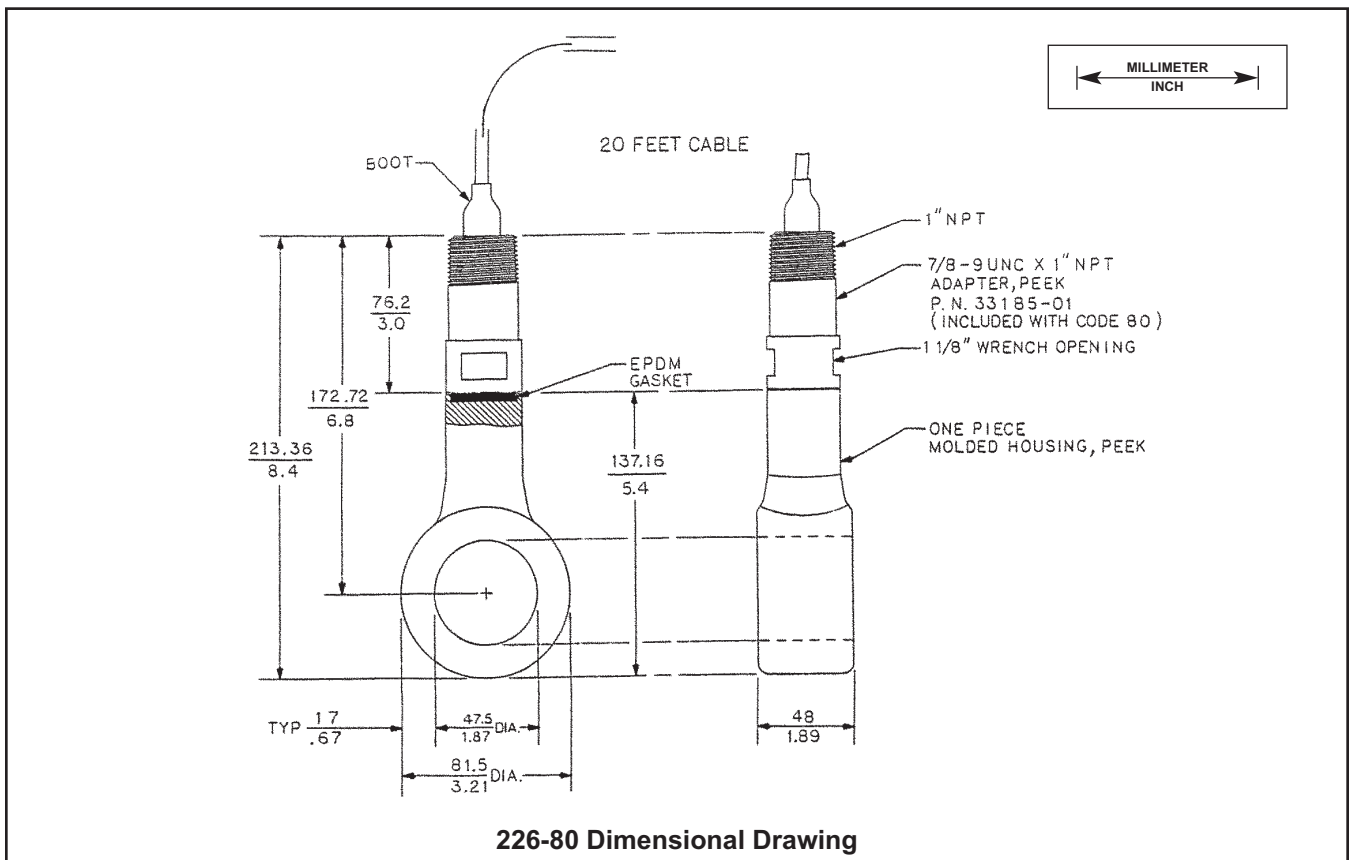

SPECIFICATIONS (Model 226 - continued)

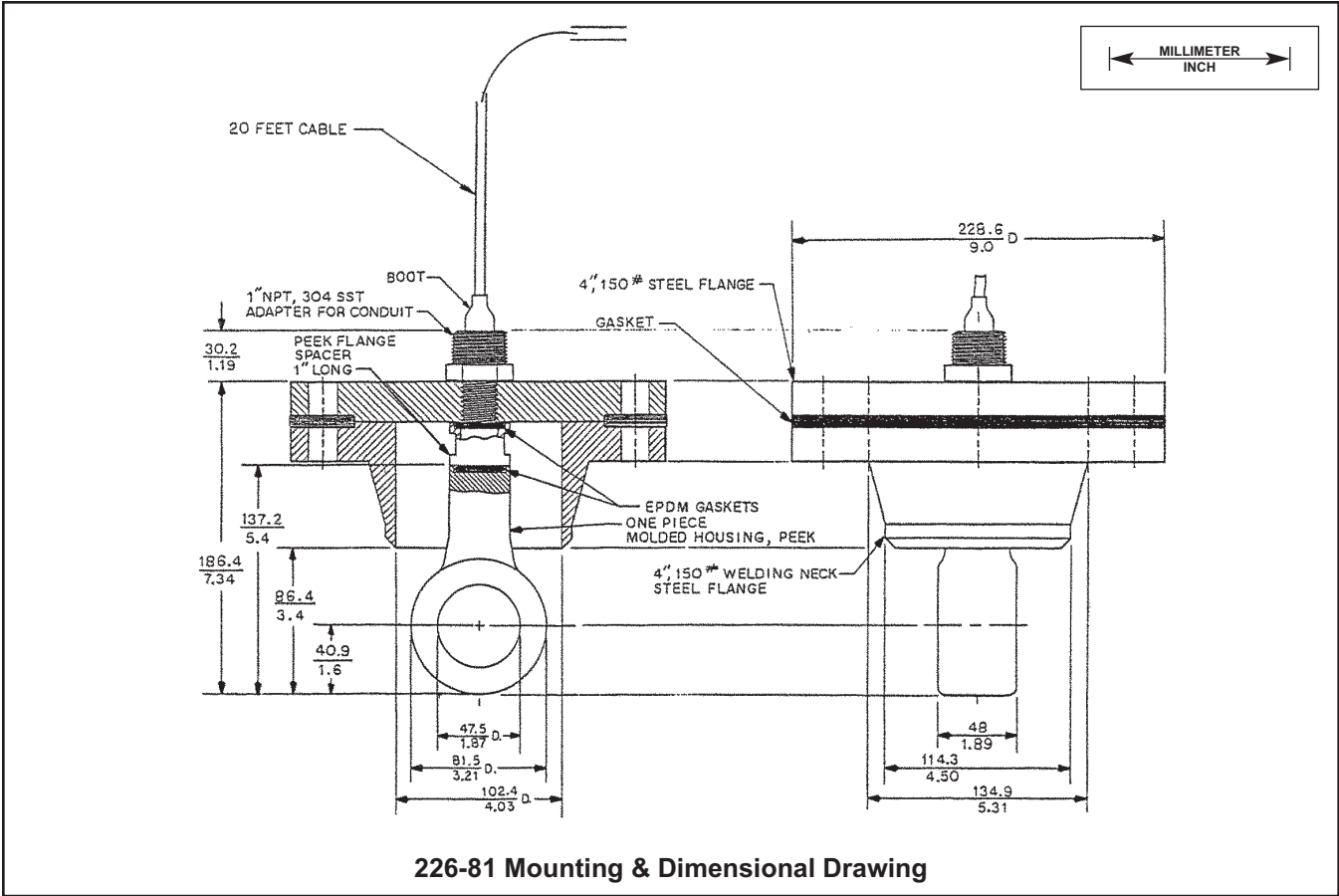

SPECIFICATIONS (Model 228)

Conductivity range:

analyzer	minimum	maximum
1056 and 56	15 uS/cm	1500 mS/cm
all others	200 uS/cm	2000 mS/cm

Wetted materials:

option	wetted materials
-02 and -03	glass-filled PEEK
-04	glass-filled Tefzel
-05	unfilled Tefzel
-20	has EPDM gasket

Process connection:

option	connection
-20	5/8-inch 11 UNC
-21	3/4-inch MNPT

Temperature and pressure:

option	temperature (max.)	pressure (max.)
-02	248°F (120°C)	295 psig (2135 kPa)
-03	392°F (200°C)	295 psig (2135 kPa)
-04	248°F (120°C)	200 psig (1480 kPa)
-05	248°F (120°C)	200 psig (1480 kPa)

Pressure (for CRN registration only):

option	pressure (max.)
-02	220 psig (1618 kPa abs)
-03	220 psig (1618 kPa abs)
-04	150 psig (1135 kPa abs)
-05	150 psig (1135 kPa abs)

Cable length: 20 ft (6.1 m)

Maximum cable length: 200 ft (61 m)

Installation: Install the sensor so that it is completely immersed in the process liquid. Mounting in a vertical pipe run is best. If the sensor must be installed in a horizontal pipe run, place the sensor in the 3 o'clock position.

Weight/shipping weight: 2 lb/3 lb (1.0 kg/1.5 kg)

(rounded up to nearest 1 lb or 0.5 kg)

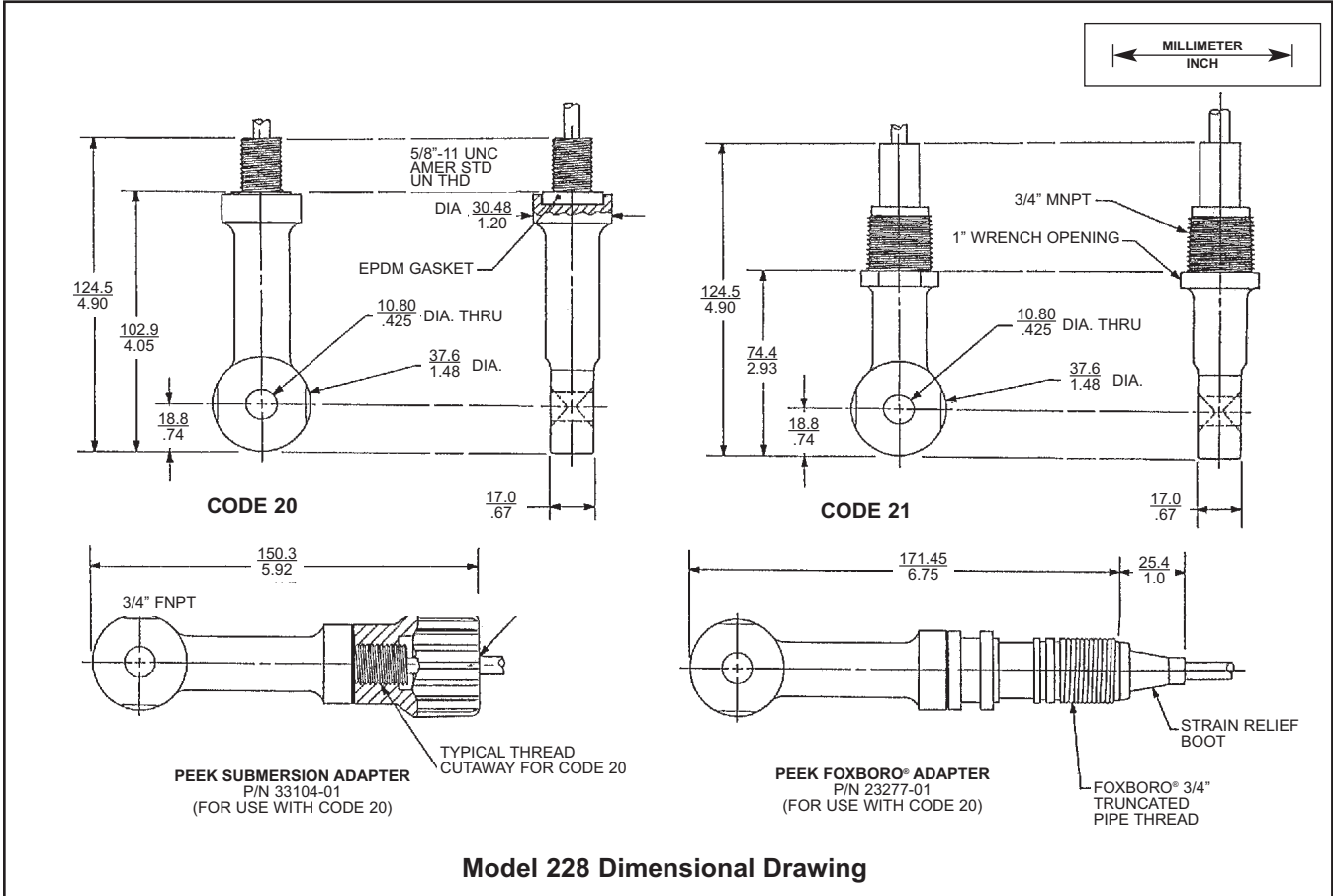

SPECIFICATIONS (insertion adapters for Model 228 sensor)

Sensor compatibility:

PN	use with
23242-02	228-21
23242-03	228-20
2001990	228-21

Process connection:

PN	process connection
23242-02	1-1/2 inch MNPT
23242-03	1-1/2 inch MNPT
2001990	2 inch MNPT

Wetted materials:

PN	wetted materials
23242-02	316 stainless steel, glass-filled PEEK, Viton ^{®2}
23242-03	316 stainless steel, glass-filled PEEK, Viton
2001990	CPVC, Viton

Temperature and pressure:

PN	temperature (max.)	pressure (max.)
23242-02	392°F (200°C)	295 psig (2135 kPa abs)
23242-03	392°F (200°C)	295 psig (2135 kPa abs)
2001990	100°F (38°C) 185°F (85°C)	100 psig (791 kPa abs) 45 psig (412 kPa abs)

Pressure (for CRN registration only):

PN	pressure (max.)
23242-02	220 psig (1618 kPa abs)
23242-03	220 psig (1618 kPa abs)
2001990	NA

Installation: Install the sensor so that it is completely immersed in the process liquid. Mounting in a vertical pipe run is best. If the sensor must be installed in a horizontal pipe run, place the sensor in the 3 o'clock position.

Weight/Shipping weight:

PN	Weight	Shipping Weight
23242-02	3 lb (1.5 kg)	4 lb (2.0 kg)
23242-03	3 lb (1.5 kg)	4 lb (2.0 kg)
2001990	1 lb (0.5 kg)	2 lb (1.0 kg)

(rounded up to nearest 1 lb or 0.5 kg)

²Viton is a registered trademark of DuPont Performance Elastomers.

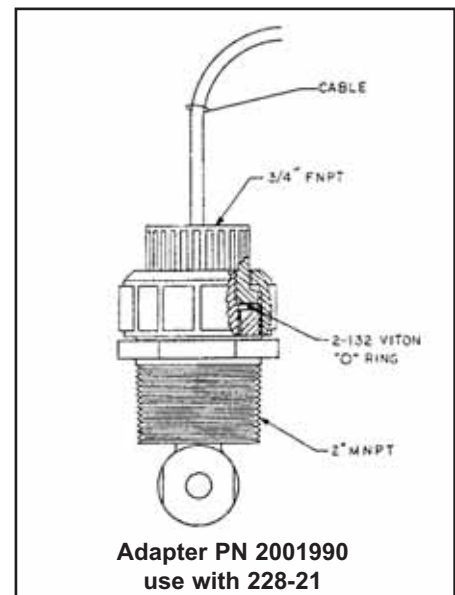
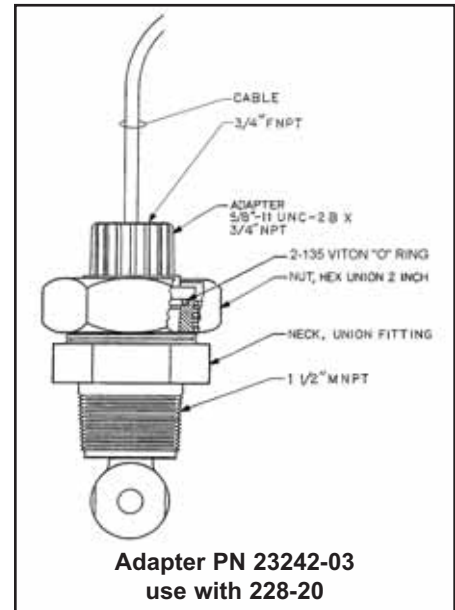
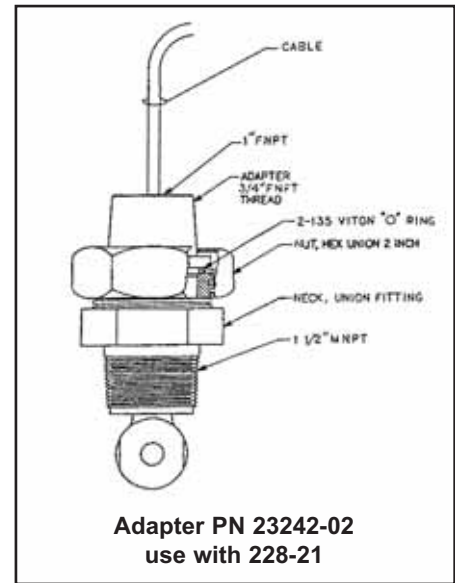

SPECIFICATIONS (retraction assemblies for Model 228 sensor)

Sensor compatibility: The retraction assemblies are used with 228-[]-20-54-62 only.

Wetted materials: 316 stainless steel, EP rubber, unfilled Teflon^{®3}, carbon-filled Teflon

Process connection: 1-1/2 inch MNPT

Temperature: 392°F (200°C) maximum

Pressure: 295 psig (2135 kPa abs) maximum

Maximum retraction/insertion conditions:

PN	description	temperature	pressure
23311-00	mechanical	392°F (200°C)	295 psig (2135 kPa abs)
23311-01	manual	266°F (130°C)	35 psig (343 kPa abs)

Maximum insertion travel:

PN	description	travel (max)
23311-00	mechanical	10.5 in (267 mm)
23311-01	manual	12.0 in (305 mm)

Installation: Install the retraction assembly so that the sensor will be completely immersed in the process liquid.

Weight/shipping weight:

PN	description	weight/shipping weight
23311-00	mechanical	12 lb/15 lb (5.5 kg/7.0 kg)
23311-01	manual	9 lb/12 lb (4.5 kg/5.5 kg)

(rounded up to nearest 1 lb or 0.5 kg)

³Teflon is a registered trademark of E.I. duPoint de Nemours and Co.

SPECIFICATIONS (Ball valve PN 9340065 for use with Model 228 retraction assemblies)

Wetted materials: 316 stainless steel, Teflon[®] TFE

Process connection: 1-1/2 inch FNPT

Pressure and Temperature: See graph

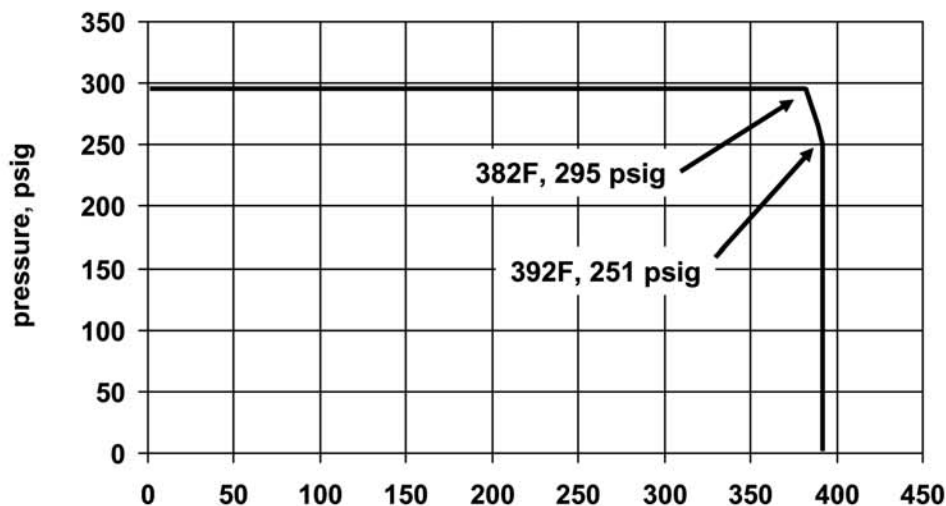

Weight/Shipping weight: 4 lb/5 lb (2.0 kg/2.5 kg)

SPECIFICATIONS (retraction assembly for Model 228 sensor)

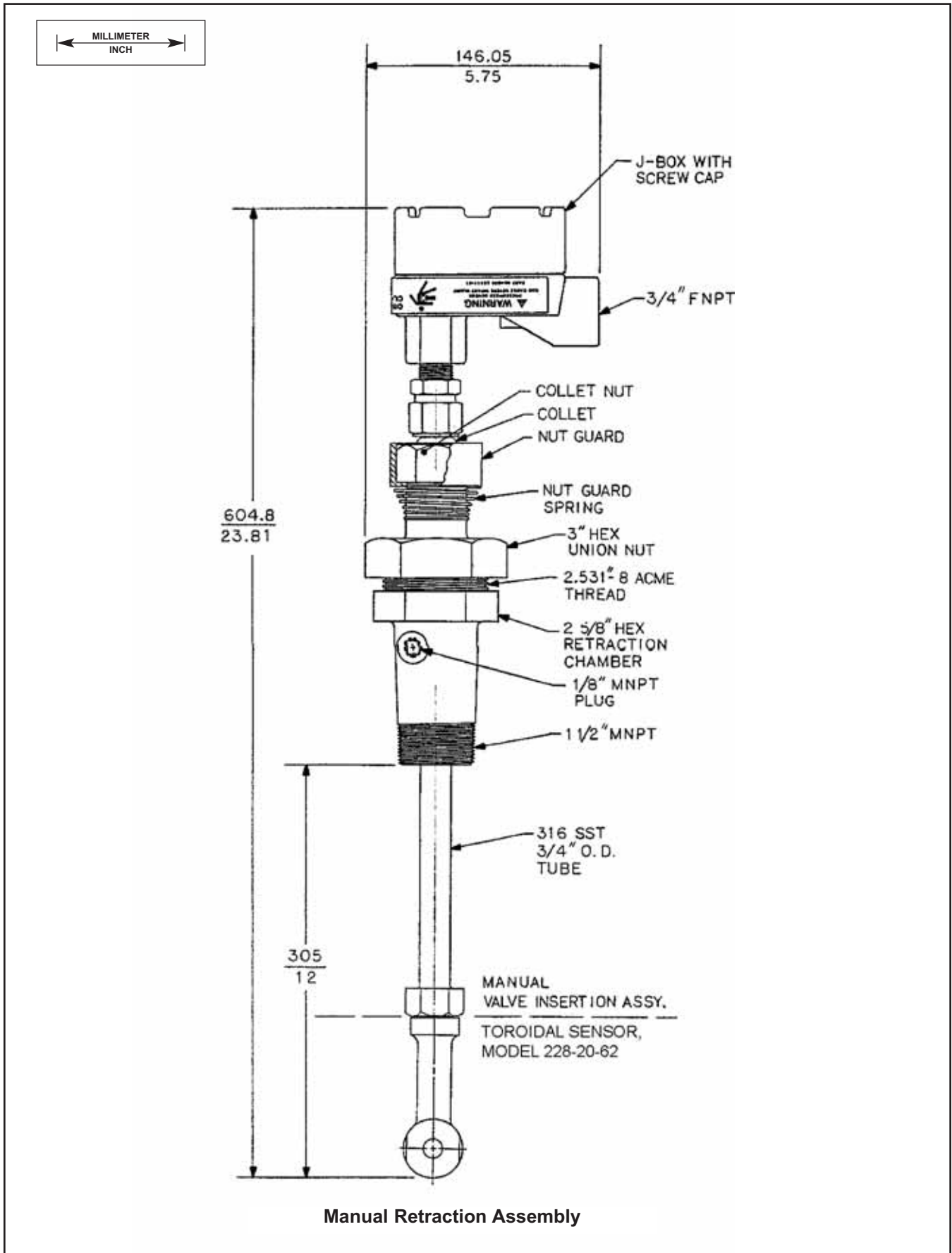

Manual Retraction Assembly

SPECIFICATIONS (retraction assembly for Model 228 sensor) cont.

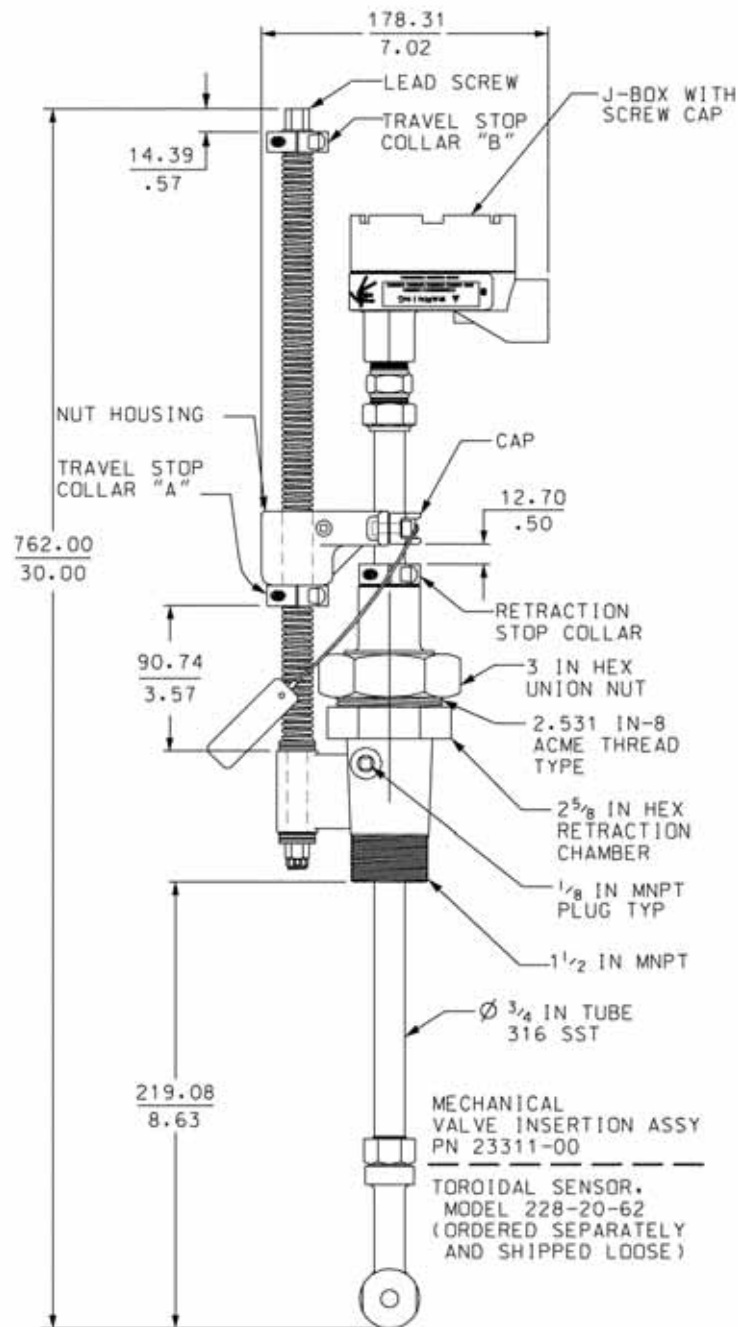

3. EXTENSION CABLE IS ORDERED SEPARATELY. SPECIFY LENGTH
2. REQUIRES CUSTOMER SUPPLIED 1 1/2 IN FPT FULL PORT BALL VALVE
1. MAXIMUM INSERTION/RETRACTION AND OPERATING CONDITIONS:
295 PSIG (2036 KPa) AND 392°F (200°C)

Mechanical Retraction Assembly

MODEL 226 TOROIDAL CONDUCTIVITY SENSOR

The Model 226 Large Bore Submersion/Insertion Toroidal Conductivity Sensor is molded of chemically-resistant glass-filled PEEK. The sensor includes an integral RTD for temperature compensation and 20 ft of cable. The sensor is compatible with the 1056, 56, 54eC, 5081-T, 1066 and Xmt-T instruments. For improved EMI/RFI shielding, choose cable option -56.

MODEL 226 LARGE BORE TOROIDAL CONDUCTIVITY SENSOR	
CODE	BODY MATERIAL (required selection)
02	Glass-filled PEEK (Note 1)
CODE	CABLE (required selection) (Note 2)
54	Standard cable
56	Cable with additional shielding for improved EMI/RFI protection (Note 3)
CODE	MOUNTING OPTIONS (required selection)
80	Submersion (see mounting and dimensional drawing)
81	Insertion through flange (see mounting and dimensional drawing)
82	No mounting kit
226	-56 -82 EXAMPLE

NOTES:

1. The sensor is supplied with an EPDM gasket. A Viton gasket is available as PN 33151-01.
2. Cables can be extended using the remote junction box PN 23550-00. See also EXTENSION CABLE on page 11.
3. Option 56 cable is recommended for use with the 1056, 56, 54eC, 5081-T, 1066, and Xmt-T instruments.

ACCESSORIES (MODEL 226 SENSOR)

PART NUMBER	DESCRIPTION
2001492	Stainless steel tag, specify marking
23550-00	Remote junction box
33151-00	Gasket, EPDM
33151-01	Gasket, Viton
33185-01	Mounting adapter, submersion, 3-in length, 1-in MNPT, PEEK (spare for 226-80)
33185-02	Mounting adapter, flange insertion, 1-in length, PEEK (spare for 226-81)
33219-00	7/8-in 9 UNC X 1-in MNPT for conduit connection, (spare for 226-81)

MODEL 228 TOROIDAL CONDUCTIVITY SENSOR

The Model 228 Submersion/Insertion Toroidal Conductivity Sensor is molded of chemically-resistant PEEK (glass-filled) or Tefzel (glass-filled or unfilled). The sensor includes an integral RTD for temperature compensation. The sensor is compatible with the 1056, 56, 54eC, 5081-T, 1066 and Xmt-T instruments. For improved EMI/RFI shielding, choose cable option -56.

MODEL					
228 INSERTION/SUBMERSION TOROIDAL CONDUCTIVITY SENSOR					
CODE	BODY MATERIAL (required selection)				
02	Glass-filled PEEK, standard temperature to 248°F (120°C)				
03	Glass-filled PEEK, high temperature to 392°F (200°C)				
04	Glass-filled Tefzel, standard temperature to 248°F (120°C) (not available with code 54-62)				
05	Unfilled Tefzel, standard temperature to 248°F (120°C) (not available with code 54-62)				
CODE	PROCESS CONNECTION (required selection)				
20	5/8-in 11 UNC, requires mounting adapter (Note 1)				
21	3/4-in MNPT (not available with code -62)				
CODE	CABLE (required selection) (Note 2)				
54-61	Standard integral cable, 20 ft				
56-61	Integral cable with additional shielding for improved EMI/RFI protection, 20 ft (Note 3)				
54-62	20-inch (508 mm) cable for connection to junction box used in retraction assembly. Requires extension cable from junction box to analyzer. (Note 4)				
228	-02	-21	-56	-61	EXAMPLE

NOTES:

1. The sensor is supplied with an EP gasket. Viton (PN 33075-00) and Kalrez (PN 33075-03) gaskets are also available.
2. Cables can be extended using the remote junction box PN 23550-00. See also EXTENSION CABLE on page 11.
3. Option 56-61 cable is recommended for use with 1056, 56, 54eC, 5081-T, 1066, and Xmt-T instruments.
4. Choose either cable 23294-00 or 23294-04. Cable 23294-04 has more EMI/RFI shielding and is recommended for use with the 1056, 56, 54eC, 5081-T, 1066, and Xmt-T instruments.

ACCESSORIES (MODEL 228 SENSOR)

PART NUMBER	DESCRIPTION
2001492	Stainless steel tag, specify marking
23550-00	Remote junction box
2001990	Mounting adapter, 2-in MNPT, CPVC for use with 228-21 (see drawing)
23242-02	Mounting adapter, 1-1/2 in MNPT, PEEK, for use with 228-21 (see drawing)
23242-03	Mounting adapter, 1-1/2 in MNPT, PEEK, for use with 228-20 (see drawing)
23277-01	Mounting adapter, Foxboro, PEEK, 5/8 11 UNC, for use with 228-20
23277-01 SQ7182	Mounting adapter, Foxboro, Tefzel, 5/8 11 UNC, for use with 228-20
23311-00	Retraction assembly, mechanical, for 228-20-54-62 only
23311-01	Retraction assembly, manual, for 228-20-54-62 only
33075-00	Gasket, Viton, for 228-20
33075-01	Gasket, EPDM, for 228-20
33075-03	Gasket, Kalrez, for 228-20

ACCESSORIES (MODEL 228 SENSOR Continued)

PART NUMBER	DESCRIPTION
33081-00 SQ7091A	Adapter insert, Tefzel, for 23242-02
33080-01 SQ7091B	Adapter insert, Tefzel, for 23242-03
33104-01	Submersion adapter, PEEK, for 228-20
9340065	Ball valve, full port, 1 1/2 inch FNPT for 23311-00 and 23311-01
9550179	O-ring, EP rubber, for 2001990

EXTENSION CABLE

All extension cable is terminated at both ends.

PN	Description
23294-00	Interconnecting cable for use with 226-54 and 228-54 sensors
23294-04	Interconnecting cable for use with 226-56 and 228-56 sensors. Cable has more EMI/RFI shielding than 23294-00, and is recommended for use with 1056, 56, 54eC, 5081-T, 1066, and Xmt-T instruments.
23294-05	Interconnecting cable for use with 228-03-56-61 (high temperature) sensors. Cable has more EMI/RFI shielding than 23294-00.

ENGINEERING SPECIFICATION FOR MODEL 226 SENSOR

1. The sensor shall measure electrolytic conductivity using the inductive or toroidal method.
2. The sensor shall have a large bore to reduce fouling from fibrous materials in the process stream.
3. The sensor shall be molded from glass-filled PEEK.
4. The sensor shall be suitable for submersion mounting or for insertion mounting through a pipe flange.
5. The sensor shall withstand 248°F (120°C) at 295 psig (2135 kPa).
6. The sensor shall be Rosemount Analytical Model 226 or approved equal.

ENGINEERING SPECIFICATION FOR MODEL 228 SENSOR

1. The sensor shall measure electrolytic conductivity using the inductive or toroidal method.
2. The sensor shall be molded from glass-filled PEEK, glass-filled Tefzel, or unfilled Tefzel.
3. The sensor shall be suitable for submersion mounting using a 3/4 inch MNPT, insertion through a pipe flange using a 5/8 inch 11 UNC thread, or insertion through an adapter. Insertion adapters shall have 1-1/2 inch MNPT connections.
4. The glass-filled PEEK sensor shall withstand 248°F (120°C) at 295 psig (2135 kPa). A high temperature glass-filled PEEK sensor that can withstand 392°F (200°C) at 295 psig (2135 kPa) shall also be available. The Tefzel sensor shall withstand 248°F (120°C) at 200 psig (1480 kPa).
5. The sensor shall be Rosemount Analytical Model 228 or approved equal.

COMPATIBLE ANALYZERS AND TRANSMITTERS

The Model 1056 Dual Input Analyzer offers the choice of single or dual sensor inputs in any combination of pH/ORP, contacting and toroidal conductivity (resistivity), chlorine, oxygen, and ozone. High purity water, percent slope, and cation conductivity temperature corrections are standard for the conductivity measurement. Conductivity readings can also be converted to TDS, % concentration, ratio, and % rejection. The large backlit display is easy to read and can be customized to fit user requirements. Diagnostic variables to aid in troubleshooting are displayed at the touch of a button. The analyzer has two fully programmable analog outputs. Programming and calibrating is so simple and intuitive that a manual is almost not necessary.



The Model 5081 Conductivity Transmitter and an Endurance Conductivity Sensor can be used to monitor conductivity or resistivity in a variety of processes. The Model 5081 uses state-of-the-art micro-processor technology. Two digital communication protocols are available: HART and Foundation Fieldbus. Digital communications allows access to AMS (Asset Management Solutions). Use AMS to set up and configure the transmitter, read process variables, and troubleshoot problems from a personal computer or host anywhere in the plant. A handheld infrared remote controller or the HART Model 275 communicator can also be used for programming and calibrating the transmitter. The remote controller works from as far away as six feet. The user-friendly menus of the Model 5081 (Calibrate/Program/ Diagnose), coupled with descriptive headers and prompts, almost eliminate the need for an instruction manual.



The Model 56 Analyzer can be used with any ENDURANCE family conductivity sensor to measure electrolytic conductivity in a variety of applications. The Model 56 can be set up as either a dual input conductivity analyzer, or the second input can be connected to a pH, ORP, chlorine, oxygen, ozone, or turbidity sensor. The analyzer has four fully programmable analog outputs and four fully programmable alarm relays, including PID and TPC control. The high contrast, full color display shows measurement results in large, easy-to-read digits. Menu screens for programming and calibration are simply and intuitive. Information screens, offering detailed explanation of programming features and calibration methods as well as troubleshooting assistance, are available at the touch of a button. An event and data logger and a dual graphical display are also standard. HART and Profibus DP digital communication are optional.



The Solu Comp Model Xmt-C Conductivity Transmitter can be used with most ENDURANCE conductivity sensors. The transmitter has a two-line display. Menu screens for calibrating and configuring are simple and intuitive. Plain language prompts guide the user through the procedures. Two digital communication protocols are available: HART (model option -HT) and FOUNDATION fieldbus (model option -FF). Digital communications allow access to AMS (Asset Management Solutions). Use AMS to set up and configure the transmitter, read process variables, and troubleshoot problems from a personal computer or host anywhere in the plant. The keypad allows local programming and calibrating of the transmitter. The HART Model 375 communicator can also be used for programming and calibrating the transmitter.



All Rosemount Analytical Conductivity Instruments feature automatic temperature correction for high purity water and cation conductivity. Programmable percent change per °C temperature correction is also available.

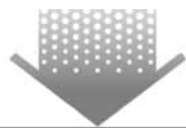

*The right people,
the right answers,
right now.*

ROSEMOUNT ANALYTICAL
CUSTOMER SUPPORT CENTER
1-800-854-8257



ON-LINE ORDERING NOW AVAILABLE ON OUR WEB SITE
<http://www.raihome.com>

Specifications subject to change without notice.



Credit Cards for U.S. Purchases Only.



Emerson Process Management

2400 Barranca Parkway
Irvine, CA 92606 USA
Tel: (949) 757-8500
Fax: (949) 474-7250

<http://www.raihome.com>

