

General Rescue Manual



New Zealand Civil Defence
Emergency Management

August 2001

Table of Contents

FOREWORD.....	1
EXPLANATION OF WARNING NOTES	1
URBAN SEARCH AND RESCUE	2
PHOTOGRAPHS.....	2
NZQA UNIT STANDARDS.....	2
CHAPTER ONE RESCUE.....	3
THE AIM OF RESCUE.....	3
FUNCTIONS.....	3
THE PSYCHOLOGY OF RESCUE.....	4
RESCUE WORKERS.....	5
<i>Group 1 – Survivors.....</i>	<i>5</i>
<i>Group 2 – Untrained Personnel.....</i>	<i>5</i>
<i>Group 3 – Trained Personnel.....</i>	<i>6</i>
PERSONAL TRAITS OF THE RESCUER	6
PERSONAL BEHAVIOUR	7
TEAM COMPOSITION.....	8
ACTIVATION	8
DEPLOYMENT.....	9
COORDINATED INCIDENT MANAGEMENT SYSTEM.....	9
CHAPTER TWO SAFETY IN TRAINING AND OPERATIONS.....	11
INTRODUCTION.....	11
THE RESPONSIBILITY FOR SAFETY	11
BASIC PRECAUTIONS	12
RESCUE / SAFETY HARNESES.....	13
CASUALTY SAFETY	14
SAFE WORKING IN A CONFINED SPACE.....	14
MOVING IN AN UNKNOWN ENVIRONMENT.....	16
SEARCHING A DARKENED ROOM	18
VEHICLE SAFETY	18
EQUIPMENT SAFETY	19
PUBLIC UTILITY HAZARDS	19
<i>General.....</i>	<i>19</i>
<i>Gas (CNG and LPG).....</i>	<i>20</i>
<i>Water.....</i>	<i>20</i>
<i>Sewers.....</i>	<i>21</i>
<i>Electricity</i>	<i>21</i>
CORRECT LIFTING TECHNIQUES	22
TEAM LIFTING	23
CHAPTER THREE RECONNAISSANCE.....	25
THE RESCUE PLAN	25
RECONNAISSANCE & RESCUE BY STAGES	25
<i>Reconnaissance & Survey.....</i>	<i>26</i>
<i>Elimination of Utilities.....</i>	<i>27</i>
<i>Primary Surface Search & Rescue</i>	<i>27</i>
<i>Exploration Of All Voids And Spaces.....</i>	<i>27</i>

<i>Access By Selected Debris Removal</i>	28
<i>Termination by General Debris Removal</i>	28
THE APPRECIATION PROCESS	28
<i>Step One – Define The Problem</i>	28
<i>Step Two – State The Aim</i>	29
<i>Step Three – Consider The Factors</i>	29
<i>Step Four – Determine Courses Open</i>	29
<i>Step Five – Decide On Best Course</i>	30
<i>Step Six – Plan</i>	30
CONTINUING ACTION	30
CALLING AND LISTENING TECHNIQUES	31
DAMAGE TO BUILDINGS	32
TYPES OF BUILDINGS.....	33
<i>Light Timber Framed</i>	33
<i>Unreinforced Masonry</i>	33
<i>Reinforced Concrete Masonry (Blockwork)</i>	33
<i>Concrete Tilt-Up</i>	33
<i>Reinforced Concrete/Structural Steel</i>	33
TYPES OF COLLAPSE.....	34
<i>The ‘V’ Type Collapse</i>	34
<i>The ‘Lean To’ Collapse</i>	35
<i>The ‘Horizontal/Pancake’ Type Collapse</i>	35
PRECAUTIONS IN OPERATIONS	36
CRUSH INJURIES	36
DEBRIS CLEARANCE	37
<i>When Debris Clearance Is Necessary</i>	37
<i>Methods Of Debris Clearance</i>	38
<i>Precautions In Operations</i>	38
BUILDING MARKING	39
<i>General Area Marking</i>	39
VICTIM MARKING	42
OTHER MARKINGS:.....	43
THE DEAD	44
<i>Identification And Removal</i>	44
<i>Suspicious Circumstances</i>	45
<i>Conduct At The Scene</i>	45
CHAPTER FOUR ROPES, TAPES, KNOTS & LASHINGS – GENERAL INFORMATION.....	47
INTRODUCTION.....	47
IDENTIFICATION.....	47
RECORD SYSTEMS	47
ROPE.....	48
TYPES OF ROPE	48
TERMINOLOGY	48
ROPE PACKAGING.....	51
<i>Stuff Sacks</i>	51
<i>Chaining</i>	51
ROPE PACKAGING (CARRYING).....	53
CLIMBING TAPES.....	53
<i>Construction</i>	54
<i>Size</i>	54
<i>Abrasion</i>	54
<i>Tape Strength</i>	54
<i>The Use of Tape</i>	55
<i>Care and Maintenance</i>	55
<i>Safety</i>	55

FLEXIBLE STEEL WIRE ROPES (SWR).....	57
<i>Safe Working Load (SWL)</i>	57
<i>Construction</i>	57
<i>Precautions in Operations</i>	58
<i>Inspection of Steel Wire Rope</i>	58
<i>Storage of Steel Wire Ropes</i>	59
VERTICAL LIFT KNOT	60
CHAIR KNOT	61
<i>Chair Knot – Alternate Method</i>	61
LASHINGS	62
<i>Square Lashing</i>	62
<i>Diagonal Lashing</i>	63
<i>Round Lashing</i>	63
<i>Figure of Eight Lashing</i>	64
CHAPTER FIVE SYNTHETIC ROPES - KNOTS	65
CONSTRUCTION.....	65
POLYAMIDE (NYLON)	66
KERNMANTEL CONSTRUCTION.....	66
STATIC KERNMANTEL ROPES	67
<i>Strength Vs Handling</i>	67
CHARACTERISTICS OF A SYNTHETIC FIBRE STATIC RESCUE ROPE.....	68
CARE AND MAINTENANCE.....	68
WASHING ROPES	69
INSPECTION.....	70
RETIRING A ROPE.....	71
RATED STRENGTH AND SAFE WORKING LOAD	72
POLYAMIDE DYNAMIC CLIMBING ROPES.....	72
SMALL DIAMETER KERNMANTEL CORDS	73
OTHER SYNTHETIC FIBRE ROPES.....	73
<i>Materials</i>	73
<i>Rated Strength and Safe Working Load</i>	73
<i>Care, Maintenance, and Safe Operations</i>	74
KNOTS	74
<i>Stopper Knot</i>	74
KNOTS FOR SYNTHETIC FIBRE RESCUE ROPES	74
<i>Thumb Knot</i>	74
<i>Figure 8 Knot</i>	75
<i>Figure 8 Knot (Single Figure 8)</i>	75
<i>Rethreaded Figure 8</i>	76
<i>Figure 8 Joining Knot (Figure 8 Bend)</i>	76
<i>Double Figure 8 on a Bight (Anchor 8 or Industrial 8)</i>	77
<i>Round Turn and Two Half Hitches</i>	77
<i>Alpine Butterfly</i>	78
<i>Double Fisherman’s Knot</i>	79
<i>Prusik Knot</i>	80
<i>Friction Hitch</i>	81
CHAPTER SIX NATURAL FIBRE ROPES - KNOTS	83
INTRODUCTION.....	83
CONSTRUCTION.....	83
CARE AND MAINTENANCE.....	84
INSPECTION OF LAID ROPE	85
RATED STRENGTH AND SAFE WORKING LOAD (SWL).....	86
ROPE PACKAGING.....	87
WHIPPING ROPE ENDS	87

KNOTS	87
<i>General Purpose Knots</i>	88
KNOT SAFETY.....	92
KNOT STRENGTH.....	92
CHAPTER SEVEN ANCHORS AND HOLDFASTS.....	93
INTRODUCTION.....	93
NATURAL ANCHORS	93
CONSTRUCTED ANCHORS	93
<i>Picket Holdfasts</i>	93
<i>Buried Holdfasts</i>	95
<i>Log And Picket Holdfasts</i>	96
IMPROVISED ANCHORS.....	96
PRECAUTIONS IN OPERATIONS	96
SELECTION OF ANCHORS	97
SLING LOADING ANGLES.....	97
ATTACHMENT TO ANCHORS	98
KARABINERS	99
SHACKLES	101
SAFETY SUMMARY.....	102
CHAPTER EIGHT LADDERS	103
INTRODUCTION.....	103
CONSTRUCTION.....	103
EXTENSION LADDERS.....	103
STEPLADDERS	104
TERMINOLOGY	105
SINGLE RESCUER LADDER RAISE.....	106
ERECTING AND EXTENDING THE LADDER (TWO RESCUERS).....	106
ERECTING AND EXTENDING THE LADDER (THREE RESCUERS).....	107
ANGLE OF LADDERS WHEN RAISED	108
OVERLAPS	108
SECURING THE HEAD OF THE LADDER.....	109
SECURING THE FOOT OF THE LADDER	109
HALVING LADDERS	109
LADDER CLIMBING.....	110
HELPING A CASUALTY DOWN A LADDER.....	111
MAINTENANCE AND TESTING	112
CHAPTER NINE CASUALTY HANDLING TECHNIQUES.....	113
INTRODUCTION.....	113
TRIAGE.....	114
CASUALTY SORTING.....	115
CASUALTY TAGS	116
STRETCHERS.....	116
FOLDING OR POLE STRETCHERS	117
BLANKETING THE STRETCHER.....	118
LOADING A STRETCHER	120
<i>The Four Rescuer Method</i>	120
<i>Blanket Lift (Four Or Six Rescuers)</i>	121
<i>Clothing Lift (Three Rescuers)</i>	122
<i>Webbing Bands (Five Rescuers)</i>	122
<i>Specialist Lifting/Loading Devices</i>	123
LASHING THE CASUALTY TO THE STRETCHER.....	123
<i>Lashing - Lateral/Recovery Position</i>	124

BOARD RESCUE STRETCHERS.....	125
<i>Board Rescue Stretcher Lashing</i>	126
<i>Attaching Lowering Lines To The Board Rescue Stretcher</i>	127
BASKET STRETCHERS.....	127
<i>Blanketing A Basket Stretcher</i>	128
<i>Securing A Basket Stretcher With Securing Straps</i>	128
<i>Securing A Basket Stretcher By Lashing</i>	129
WRAP AROUND STRETCHERS	130
MOVING A STRETCHER OVER UNEVEN GROUND.....	131
MOVING A STRETCHER IN CONFINED SPACES	132
PASSING A STRETCHER OVER A GAP.....	133
CHAPTER TEN IMPROVISED CASUALTY MOVEMENT.....	135
RESCUE TECHNIQUES USING NO EQUIPMENT	135
ONE RESCUER HANDLING TECHNIQUES	135
<i>One Rescuer Human Crutch</i>	135
<i>Pick-A-Back</i>	136
<i>Pack Strap Carry</i>	136
<i>Fire-Fighter's Crawl</i>	137
<i>Removal Down Stairs Method</i>	137
TWO RESCUER HANDLING TECHNIQUES	138
<i>Two Rescuer Human Crutch</i>	138
<i>Two-Handed Seat</i>	138
<i>Three-Handed Seat</i>	138
<i>Four-Handed Seat</i>	139
<i>The 'Fore and Aft' Method</i>	139
IMPROVISED STRETCHERS.....	140
<i>Platform Stretchers</i>	140
<i>Pole Stretchers</i>	140
<i>Bush Stretchers</i>	141
<i>Ladders</i>	141
<i>Chairs</i>	142
CHAPTER ELEVEN LIFTING & LOWERING TECHNIQUES.....	143
INTRODUCTION.....	143
MECHANICAL LOWERING METHODS	143
STRETCHER OPERATIONS.....	144
GUIDE AND SAFETY LINES.....	144
IMPROVISED SINGLE POINT LOWER	144
TWO-POINT VERTICAL SUSPENSION.....	145
FOUR-POINT HORIZONTAL SUSPENSION	147
LADDER HINGE	148
LADDER SLIDE	150
LADDER DERRICK.....	152
THE JIB.....	154
TRIPODS (OR GYNS).....	156
CHAPTER TWELVE PULLEY SYSTEMS, WINCHES & LIFTING EQUIPMENT.....	159
PULLEY SYSTEMS	159
TERMINOLOGY	159
TYPES OF PULLEYS.....	160
CHARACTERISTICS OF A LIGHTWEIGHT RESCUE PULLEY	161
CONSTRUCTING PULLEY SYSTEMS.....	161
TYPES OF PULLEY SYSTEMS.....	162
MECHANICAL ADVANTAGE.....	162

IMPROVISED HOOK MOUSING	163
PRECAUTIONS IN OPERATIONS	163
LIFT / LOWER ROPE RESCUE DEVICES.....	164
<i>Pulley systems</i>	164
<i>Drum systems</i>	165
OPERATIONAL USAGE – STANDARD PROCEDURES	165
TIRFOR STYLE WINCHES	166
<i>The Tirfor Kit</i>	167
<i>Precautions In Tirfor Operations</i>	167
<i>Safety Features Of Tirfor</i>	168
THE RATCHET WINCH.....	168
VEHICLE-MOUNTED POWER WINCHES	169
<i>Precautions In Operations</i>	169
LEVERS	171
<i>Fulcrum Blocks</i>	171
<i>Lifting</i>	171
HYDRAULIC RESCUE EQUIPMENT	172
CHAPTER THIRTEEN LIGHTING, POWER & CUTTING EQUIPMENT	173
GENERATORS	173
ELCB'S AND RCD'S	173
POWER OUTPUT OF THE GENERATOR.....	174
PRECAUTIONS IN OPERATIONS	175
ELECTRICAL SAFETY PRECAUTIONS.....	176
GENERATOR MAINTENANCE & OPERATIONAL CHECKS	176
GENERATOR STORAGE.....	177
LIGHTING.....	177
<i>Positioning Lighting</i>	178
HAND TOOLS FOR CUTTING	178
<i>Bolt Cutters</i>	178
<i>Hacksaw</i>	178
<i>Axe</i>	179
<i>Handsaws</i>	179
CHAPTER FOURTEEN FIRES AND ELEMENTARY FIRE FIGHTING	181
RESPONSIBILITY FOR FIRE FIGHTING	181
THE CHEMISTRY OF FIRE.....	181
THE CHEMISTRY OF FIRE EXTINCTION.....	182
CLASSES OF FIRE.....	183
STANDARD FIRE EXTINGUISHER OPERATING PROCEDURES:	184
FIRE HOSE REELS	184
ACTION TO BE TAKEN BY A PERSON DISCOVERING A FIRE	184
WORKING AND MOVING IN SMOKE	185
CHAPTER FIFTEEN RESCUE TEAM EQUIPMENT	187
PERSONAL EQUIPMENT.....	187
RESCUE TEAM EQUIPMENT LIST (SUGGESTED ONLY).....	188
APPENDIX	189
INDEX OF PHOTOGRAPHS ON CD-ROM AND WEBSITE.....	189

Foreword

The purpose of this manual is to provide a basic reference for rescue training, and operations. It covers basic and general equipment, systems, and techniques, rather than any specialised skill, and should be used in planning, training, and operations.

Rescue, by its very nature, is a high-risk activity. The Ministry of Civil Defence and Emergency Management accepts no responsibility for any accident caused by misuse or misinterpretation of information contained in the manual.

As situations change, and improved techniques are developed, this manual will be updated and amended.

The use of trade or brand names in this manual is not intended to be restrictive, preferential, or promotional. Rather, trade names are used where descriptive clarity is required.

EXPLANATION OF WARNING NOTES

Warning notes are included to bring your attention to specific safety and other serious issues. Completion of the activities in this manual must not be taken as having the necessary skills to teach, instruct, or advise on its contents.

WARNING NOTE:

Reading this manual alone cannot be considered adequate training.

Practical experience and strict adherence to safety standards and procedures must be adhered to.

WARNING NOTE:

Some of the techniques described in this manual are of an improvised nature and involve the use of items of equipment, such as ladders, in other than their normal operation.

These improvised techniques are included, as it is likely that they will have a wide application in rescue operations during a disaster.

URBAN SEARCH AND RESCUE

New Zealand is moving towards the internationally accepted structure of Urban Search And Rescue (USAR). Civil Defence general rescue is one of the core activities of USAR Category 1 (Awareness).

It is intended that all Civil Defence Emergency Management volunteers will complete the USAR Category 1 (Awareness) training as soon as practicable after the resources are made available.

USAR Category 1 (Awareness) is a pre-requisite for Civil Defence general rescue activities.

PHOTOGRAPHS

There is an additional folder on the CD Rom, and on the Ministry of Civil Defence and Emergency Management Website (www.mcdem.govt.nz) that contains a number of colour photographs of activities contained in this manual. These compliment the information in the manual, and are available as teaching aids. There is an index of the photographs included as Appendix I.

NZQA UNIT STANDARDS

New Zealand is using NZQA Unit Standards to formally recognise the skills and abilities of people. Many of the activities undertaken in the rescue field have Unit Standards available.

Personnel interested in pursuing these Unit Standards should talk to the Civil Defence Emergency Management Officer of their Organisation.

CHAPTER ONE

RESCUE

THE AIM OF RESCUE

To save the greatest number of lives in the shortest possible time and to minimise further injury to people and damage to property.

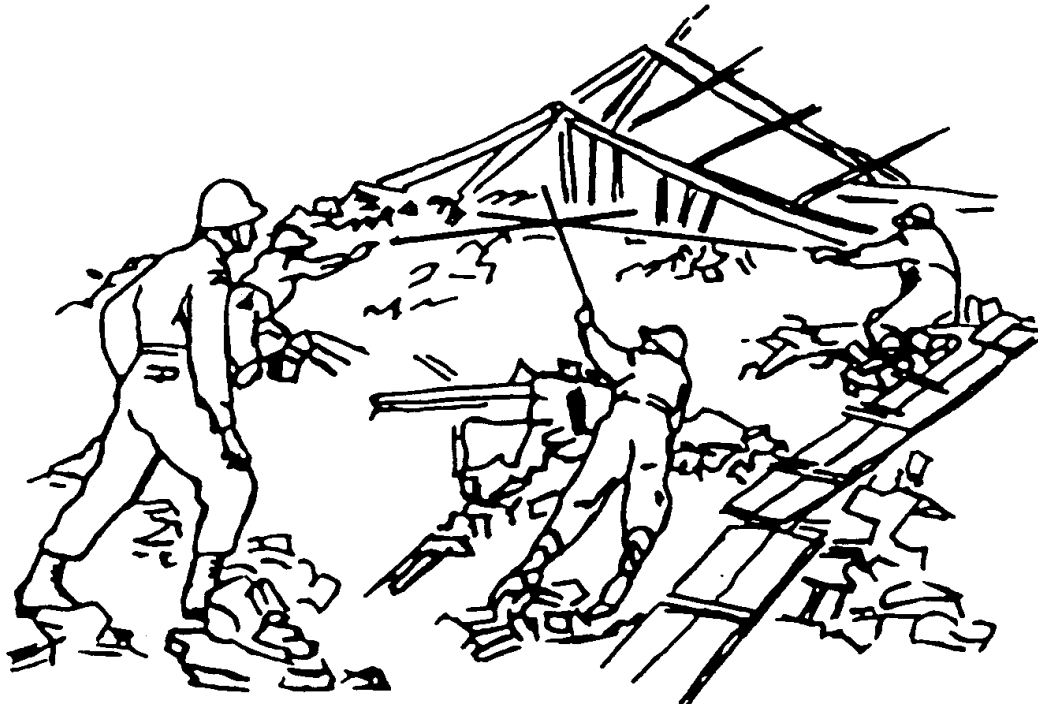

FUNCTIONS

Common rescue functions include:

- Access to, and the support and removal of, trapped people in the course of rescue operations.
- Assistance with the recovery of the dead.
- Provision of support on request to other services, authorities or specialist teams.

WARNING NOTE:

In order to achieve the aim of rescue, all rescuers must be trained in basic life sustaining first aid to recognised standards.

THE PSYCHOLOGY OF RESCUE

A moments reflection is all that is needed to realise that any situation requiring a rescue operation, by definition is one which contains either dangerous or potentially dangerous elements.

People tend to react differently to danger, but the most general responses are anxiety and fear, perhaps the most powerful of all emotions. It must be remembered that is not just the victim who faces the danger; in order to rescue the victim the rescuer must first enter the site of the dangerous situation and face the same danger. Even if the main danger has struck and passed, additional dangers are still often present. The difference between the victim and the rescuer is that the rescuer is better able to cope with, or handle, the situation. This is because the rescuer has the knowledge and the resources to minimise risk and remedy the situation.

It is normal to be anxious and feel fear in the face of danger. These are emotional reactions common to both victim and rescuer. Many other emotional responses may become manifest during a rescue situation—pity, disgust, contempt, pride, concern, and many more. These are often exaggerated beyond all reason by the urgency and pressures of the situation, thus lowering the efficiency of the overall operation.

The rescuer must be aware of the psychological needs of the victims, not just their physical needs, and be prepared to meet these psychological needs.

RESCUE WORKERS

An event requiring rescue operations will usually create three categories of rescue workers:

Group 1 – Survivors

The immediate reaction of survivors in a major incident, once they have discovered that they are not injured, is to help their neighbours and families. They often do not know what to do, but obviously it is a serious situation and thus they feel they must do something.

These good intentions could aggravate the conditions of those being 'helped' to the point where the loss of life may be greater than it should be. They could also get in the way and interrupt the functioning of trained rescue teams. However, uninjured and slightly injured survivors could well be the only hope of survival for many victims (e.g. if toxic gases, dangerous chemicals, fire, or danger of fire exist at the site of the emergency). The first group to commence rescue work at a site consists of those survivors still physically capable of doing so. The potential for good is enormous but the danger inherent in rescue work by untrained personnel is also enormous.

Group 2 – Untrained Personnel

The second 'wave' of rescue workers is drawn from people either witnessing the event from the immediate vicinity, or are drawn to the site by curiosity and a desire to assist the victims. Although not quite as emotionally involved as the survivors, the danger inherent in utilising untrained personnel is still a factor which must be considered. On the positive side, they often bring necessary resources with them and can be effective if brought under control and properly supervised.

Unfortunately, a large number of the 'curious' are just that. They have no desire to help, but just look. They get in the way, shout advice, and generally add to the excitement of the site – the very thing that is least needed, especially from the standpoint of victims.

Group 3 – Trained Personnel

The last group to arrive at the scene is the trained rescuers: Police, Fire, Civil Defence, etc. It takes some time for various emergency services to mobilise and arrive at the scene. The quicker they can arrive, the less time there will have been for the first two groups to aggravate the situation and create more dangers to surviving victims and themselves. The well-trained team will know what to do, and how to utilise the available resources and untrained personnel in efficiently carrying out the necessary tasks in a manner that will not further endanger anyone.

PERSONAL TRAITS OF THE RESCUER

Rescue work is not an easy task, nor is it necessarily a 'glamorous' one. Certainly, not all people are suited to such work. Physical fitness, personality, and emotional stability are all factors in determining one's suitability.

Ideally, the rescuer will have the following qualities:

- **Interest**—A genuine interest in rescue work, not just because of peer pressure, trying to impress, etc.
- **Training**—The will to continually undergo training to maintain a professional standard.
- **Cooperation**—Rescue work is usually a team effort, hence cooperation with others is vital.
- **Dependability**—The lives of victims, and team members rely on you.
- **Initiative**—The nature of rescue operations is such that it is often impossible to closely supervise each team member. Each must be able to see what needs doing, set priorities, and do the tasks at hand.
- **Versatility**—Each situation is unique. An individual must be able to apply a wide range of skills and knowledge to new situations.
- **Physical Fitness**—Rescue work of any kind is physically demanding and often continues for long periods. Any physical limitations must be recognised and taken into consideration.
- **Leadership Qualities**—Required by all rescuers at various times and to varying degrees. Through the capable leadership of trained rescuers, many more untrained personnel may be utilised.

- **Control over Fears and Phobias**—It is important that rescuers know what they can and cannot do. Part of this knowledge consists of being aware of any phobias. It is also vital that the leader of a rescue team knows of any phobias in team members. Some phobias that could seriously affect a rescuer and which may be identified in training are:
 - The sight of blood (Hemophobia)
 - The fear of heights (Acrophobia)
 - The fear confined spaces (Claustrophobia)
 - The fear of water (Hydrophobia)
- **Good Dress and Bearing**—Appearance should instil confidence in others.

PERSONAL BEHAVIOUR

The conduct of individuals says a lot about their psychological makeup and personality. The nature of rescue work is such that it is particularly important that personal conduct does not aggravate matters, but rather assists in creating a feeling that the situation is in competent hands, and everything possible is being done to rescue and care for the victims.

A few of the more important general areas of conduct or behaviours follow:

- **Attitude**—A serious, professional attitude must be maintained to gain confidence and support. Arrogance and superiority create instant antagonism. Loud talking, joking, and horseplay reduce credibility; they create a feeling of resentment and disgust and add to the confusion, thus hindering the work and adding to the state of anxiety of the victims. Rescuers cannot consider themselves 'professional' if they add to the confusion by loud shouting or frantic gestures.
- **Emotions**—Emotions are hard to control in the best of circumstances. In a disaster the control of emotions is a very difficult task but every effort must be made to prevent emotions from influencing good judgement and competence. Regardless of the excitement and the severity of the incident the rescuer must be able to remain calm, and be sympathetic without becoming emotionally involved.

- **Courtesy**—Courtesy, tact, and good judgement are vital if the rescue task is to be completed quickly and effectively. Courtesy must be given to all concerned.
- **Confidentiality**—During rescue activities and training there may be times when you will see and hear things which will be deemed confidential. It is essential that you appreciate this and be 'professional' and do not discuss these matters inappropriately.

TEAM COMPOSITION

Team composition will be determined by the various organisations within each area on the basis of safe accomplishment of set tasks. Regardless of the team composition, a team leader must be appointed. A team of 6 – 8 members is required for effective general rescue teamwork.

ACTIVATION

Each team should have a callout system established, and have determined the time necessary to ensure a full team response. This system should include such details as:

- Who calls out the team
- Who will be responsible for them
- Where to report
- What functions the team will perform
- What equipment to take
- Likely duration of task or event.

Where possible, rescue team members should not be members of like organisations or Emergency Services. If there is likely to be a conflict of interest between organisations, rescue team members need to determine their priorities and ensure that the Civil Defence Emergency Management Organisation is aware of this.

DEPLOYMENT

- On call-out, teams should state clearly to the organisation requesting their support, details of accommodation and any feeding assistance that may be required.
- If practicable, each team should be self-sufficient in the provision of food for the first 24 hours.

COORDINATED INCIDENT MANAGEMENT SYSTEM

CIMS (the Coordinated Incident Management System) provides the model for command, control, and coordination of an emergency response. It provides a means of coordinating the efforts of agencies as they work towards the common goal of stabilising an incident and protecting life, property, and the environment.

This is a separate course in its own right. For further information refer to the Coordinated Incident Management System (CIMS) Manual – Teamwork in E m e r g e n c y M a n a g e m e n t .

CHAPTER TWO

SAFETY IN TRAINING AND OPERATIONS

INTRODUCTION

The task of rescue involves the training of individuals and teams in a variety of skills, some of which, unless properly carried out, may well prove dangerous to the individual rescuer, the team, casualties, or bystanders. In all cases, the safety of rescuers is of prime importance.

It is therefore necessary, particularly in the early stages of training and exercises, to pay a great deal of attention to safety measures, and to emphasise the need to strictly observe and enforce these measures.

WARNING NOTE:

All rescue training and operations must be carried out with due regard to safe work practices, occupational health and safety requirements, and codes of practice and guidelines.

Many of the safety precautions to be observed are merely common sense. Unfortunately, they are so basic and simple they are often overlooked.

THE RESPONSIBILITY FOR SAFETY

Safety is the principal consideration in any rescue activity and it is the responsibility of each rescuer to ensure that safety procedures and Occupational Health and Safety requirements are followed, instructions observed, and operations carried out with a minimum of risk.

There are a number of guidelines, codes of practice, regulations, and procedures that relate to safety, and to operational aspects such as critical incident stress, and risk management. These are constantly being amended and updated – it is the responsibility of organisations to keep current.

Additionally, individual services have procedures for the management of these factors, and for laying out individual and organisational responsibilities. All of these factors must be taken into account in the management of rescue activities.

This section covers the key points of safety in training and operations as they affect the rescuer, the casualty, or the bystander. Specific safety points will be covered with each rescue technique, as they affect the conduct of that rescue technique.

BASIC PRECAUTIONS

Safety Officers should be appointed for any rescue activity. Team Leaders and Safety Officers are responsible for safety at all times. The orders given by these officers are to be obeyed without question or delay, as they are vital to safety.

Equipment must be regularly and carefully checked both before and after use. Ropes can wear and rot, batteries can corrode equipment, and machinery can break down. Faulty equipment can cost lives.

Any faulty or suspect equipment must be labelled immediately and removed for repair or replacement (e.g. the rope that a rescuer used, but did not check, and was damaged; may kill someone next time it is used).

Personnel 'at risk' by working at heights or depths must be protected by properly established and monitored safety lines and systems.

Wherever possible, rescuers should adhere to standard techniques and practices.

In any rescue technique, safety limits and margins have been built in for casualty and rescuer protection. These must never be ignored or exceeded.

WARNING NOTE:

Under no circumstances is smoking permitted in the rescue environment.

Protective clothing and helmets are issued to each rescuer. Each has an obvious safety application, and they must be properly used.

Helmets, in particular, must be worn at all times of risk, whether great or small. They are designed to protect the wearer from a **single** impact, then be replaced. They must never be mistreated by dropping, throwing, or being sat on. They should never be exposed to the effects of UV for prolonged periods (e.g. by being left on the back window-ledge of cars, or any other place).

All safety equipment must be maintained and replaced in accordance with the manufacturer's recommendations.

For training and operations, other items such as protective clothing, foul weather gear, debris gloves, safety goggles, ear protection, and safety harnesses may be issued. These are all for specific purposes, and must be treated and issued with utmost care.

RESCUE / SAFETY HARNESSSES

Personnel working at heights or in similar dangerous environments may require the protection and safety of a harness. A properly fitted climbing, rescue, or safety harness is recommended, and waist belts or safety lines are a minimum requirement if harnesses are not available. A certified Karabiner should be used for harness attachment with the rope or strop secured to the harness by this device at an approved point.

Some industrial safety harnesses are not suitable for rescue, as the location of the attachment points may be not suitable for rescue techniques. They are however,

acceptable for low risk static situations. Competent advice should be obtained before their purchase and use is required.

CASUALTY SAFETY

It must be obvious that the safety of casualties is important. Every effort including the use of protective equipment must be made to ensure that casualties come to no further harm once a rescue team arrives at the scene.

WARNING NOTE:

Horseplay or casual handling of casualties is unsafe and must not be tolerated.

For the sake of realism in training it is an advantage to use live casualties in exercises and drills. Teams should bear in mind the added safety required when dealing with heights, water, and contaminated areas, where dummy casualties may be substituted. In most cases, it is only by handling live casualties in training and exercises that rescuers will appreciate the problems they will encounter on operations.

SAFE WORKING IN A CONFINED SPACE

WARNING NOTE:

Activities in a confined space must only be undertaken by appropriately trained and qualified personnel.

In rescue operations, many environments may fall within the definition of confined spaces as laid down in Standard AS/2865:1995 (Safe Work in Confined Spaces).

A confined space is defined as an enclosed or partially enclosed space which:

- Is at atmospheric pressure during occupancy

- Is not intended or designed primarily as a place of work
- May have restricted means for entry and exit
- May have an atmosphere which contains potentially harmful levels of contaminant
- Does not have a safe oxygen level
- May cause you to be buried.

Rescue activities in such environments must be carried out with particular regard to the problems of breathing in dangerous atmospheres.

MOVING IN AN UNKNOWN ENVIRONMENT

When in strange surroundings and unable to see, the safest course of action is to work by touch. The need for caution is obvious and accidents can be avoided by remembering a few simple points:

The procedure for opening an outward opening door when there may be fire on the other side.



The procedure for opening an inward opening door when there may be fire on the other side.



While entering or leaving a smoke-filled room, crawl on your hands and knees. In this position you are below dangerous heated gases and the bulk of the smoke.

You will also be above toxic, heavier-than-air gases that may have been generated by burning plastics and natural materials.

Moving along a smoke-filled passageway in this manner avoids lighter-than-smoke and heavier-than-air gases.

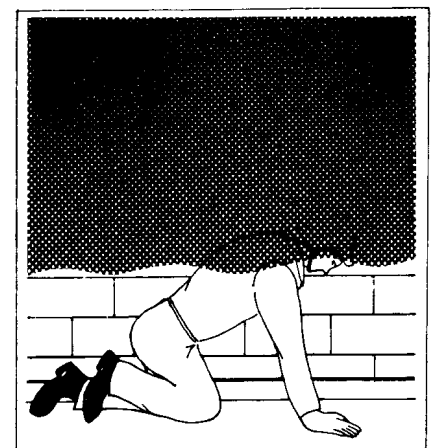

If you suspect fire is behind the door into a room, check the temperature of the door with the back of your hand.

If it is hot to touch, do not open the door, as the temperature inside is excessive.

Shuffle, don't walk. The weight of the body should be kept poised on the rear foot until the advancing foot has tested that it is safe to move forward; do not lift the feet from the ground – they should slide forward as this will help detect obstructions and dangers.

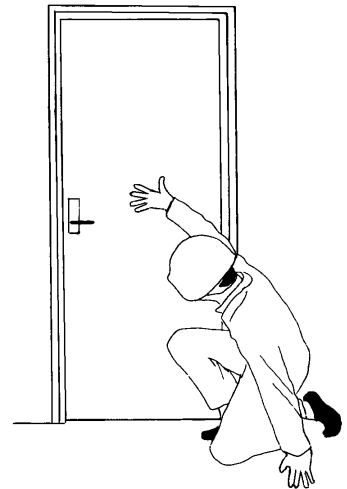

As you move forward raise your free hand in front of your face, lightly clenched, with the back uppermost, to feel for obstructions. If the back of your hand touches a live electric wire, shock will throw it clear. Your hand will not grasp the wire as it would if it were open.

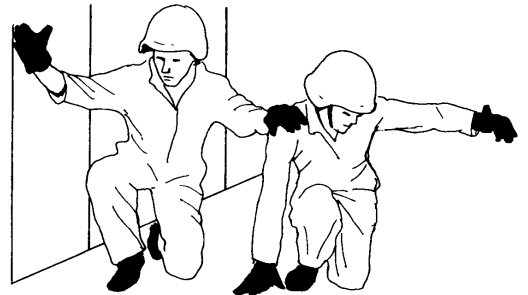

When ascending or descending stairs, keep close to the wall, since the treads will usually bear weight at this point even though their centres may be weakened. If there is any doubt as to their strength, allow only one person on each flight at any one time. The balustrade should be used with caution; it may have been weakened and may collapse if any weight is applied to it. If a stairway has been seriously damaged, use sections of extension ladders to improvise a stairway.

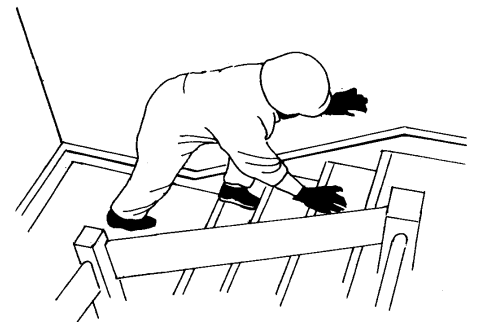

SEARCHING A DARKENED ROOM

- Make a complete circuit of the room, keeping close to the wall.
- Feel under, and on, objects (beds, etc).
- Open and feel inside cupboards, wardrobes, divans, and below other pieces of furniture.

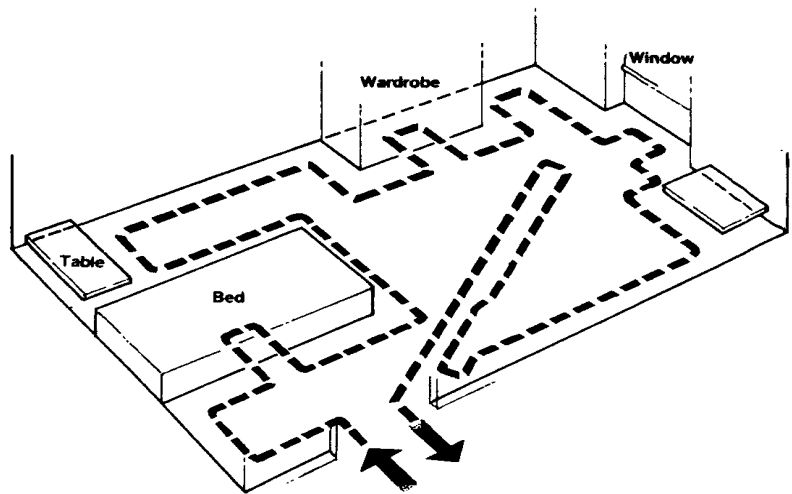

- If a complete circuit is made in this way, in an average sized room, there should be little danger of a victim being missed.
- As a final precaution, the room should be crossed diagonally to make sure that no-one is lying in the centre.
- In a larger open-plan area (office, etc.), adopt this method with diagonals to the centre of the room from each corner. Partitions and furniture will also hamper movement.

VEHICLE SAFETY

Emergency vehicles must be driven by an authorised driver in accordance with the Road Transport Act, particularly with regard to the use of warning lights and sirens. Vehicles and trailers must be maintained in first class condition, and regular checks and inspections should be routine.

Upon arrival at an accident scene, the rescue vehicle must be positioned with due regard to the site hazards, and warning devices must be used to protect the team and the vehicle.

The aim of a rescue team is to assist the public in time of need, and this should always be kept in mind when the team is travelling to an emergency. Little can be done for original casualties if the rescue team is involved in an accident en-route.

EQUIPMENT SAFETY

All equipment should be used in close compliance with the manufacturers' operating instructions, and the following basic safety rules for rescue tools and equipment should be followed:

- Safety goggles and gloves must be worn when using power tools or hammering pickets.
- Many items of equipment have been specifically designed for particular tasks. Careful safety consideration must be given before any modification of equipment, or method of use, is attempted.
- Only blades, fuel, oil, hydraulic fluid, and parts that are recommended by the manufacturer should be used.
- Petrol driven motors must never be refuelled while they are hot, and they must be kept apart from fuel supplies and casualties.
- All specific safety procedures for rescue equipment must be adhered to, and regular and careful safety checks must be carried out both before and after use.

PUBLIC UTILITY HAZARDS

General

Any emergency, from a vehicle accident to a disaster, can result in the rupture of gas and water services, or the bringing down of electrical power lines.

All utility services must be treated with the utmost care, and where possible, either the casualty removed from the source of danger, or the danger removed from the proximity of the casualty.

In a disaster, rescuers must consider their own safety as more important than any single casualty. The loss of a single rescuer could well affect the capability of the team to conduct an effective rescue and save a large number of lives. This must be weighed against the dangers involved in tackling a hazardous situation.

Gas (CNG and LPG)

Escaping gas creates the danger of explosion and the following safety precautions must be observed:

- When entering a building, if you smell gas, turn off the supply and allow time for the area to clear. Ventilation will greatly assist this.
- Never look for a leak with a match. Use soapy water, and if you find a leak, turn off the supply immediately.
- Be extremely careful of leaking liquid propane or butane. Serious frostbite burns will occur on contact with the liquid.
- If a cylinder is leaking liquid while lying on its side, stand the cylinder upright before turning the cylinder off.
- If a line is broken and the supply cannot be turned off, the line can be crimped with a pair of pliers.
- A leak that cannot be turned off can often be stopped by binding the area with a wet cloth. This will freeze over and temporarily prevent any further leak. Use thick gloves when attempting this.
- If it is not possible to stop the cylinder leaking, remove it to a safe place outdoors, keeping people and ignition sources at least 20 metres away.
- If fire is present around a cylinder, keep the cylinder cool by hosing it with a water spray.
- If a cylinder valve cannot be closed and the gas is burning, keep the cylinder cool by hosing, but do not attempt to extinguish the flame as the build-up of burned gases may explode if re-ignited.
- Never attempt to ignite a gas leak.
- Only intrinsically safe equipment should be used where gas is suspected.
- Never use power tools or oxy-acetylene torches in a confined area where gas is suspected.

Water

Water from broken mains and other sources (e.g. rain, fire fighting water, etc.) may enter areas where casualties could be trapped, especially in basement or other underground areas. The appropriate precautions must be observed.

Sewers

Broken sewers may create problems of flooding and escaping gas. Sewer gases can be explosive as well as toxic. The following basic precautions must be observed:

- Gas monitoring is essential for the safe handling of sewer gases.
- Take appropriate action prior to entering any area containing sewage.
- Never use an open flame.
- Endeavour to divert the flow away from the rescue area by building a dam or other obstruction, or by pumping.
- Personal hygiene and public health issues must be addressed in the appropriate manner.

Electricity

Live wires present a serious hazard to trapped casualties and rescue personnel, therefore the following safety precautions should be observed at all times:

- Assume all electric wires are 'live'. The fact that wires do not sputter or spark is no indication that they are dead.
- Avoid pools of water close to live wires as they may be just as dangerous as live wires.
- DO NOT attempt to cut any electrical wires.
- The supply to a damaged building should be switched off at the main switch, normally located in the meter box. The fuses should be removed and secured. Be aware; in some cases there may be more than one supply line to an individual building.

WARNING NOTE:

Even when meter box switches are off and fuses are pulled, the building will still be 'live' from the street supply to the meter box(es).

Expert assistance must be sought.

- Keep vehicles and personnel well clear of areas where wires are torn.
- Be particularly cautious at night when it is difficult to see wires. The technique of holding the back of the hand out in front of your face is advised.

CORRECT LIFTING TECHNIQUES

At all levels of rescue and training operations, rescuers will be required to lift, haul or push loads, and must be trained to handle these tasks properly and safely where mechanical aids are not available or useable

- As the leg and thigh muscles are stronger than those of the arms, back, or abdomen, it follows that these are the muscles which should be used for safe lifting.
- During a lifting operation, the rescuer should crouch down with knees bent, back straight, and feet properly placed to bear the load.
- Gripping the load correctly, the rescuer should start the lift by the thrust of the legs and continue this thrust until the legs are straight, keeping the load close to the body and keeping the back straight. In this way, the strain involved is placed on the leg muscles, and the possibility of back or abdominal injury is greatly reduced.

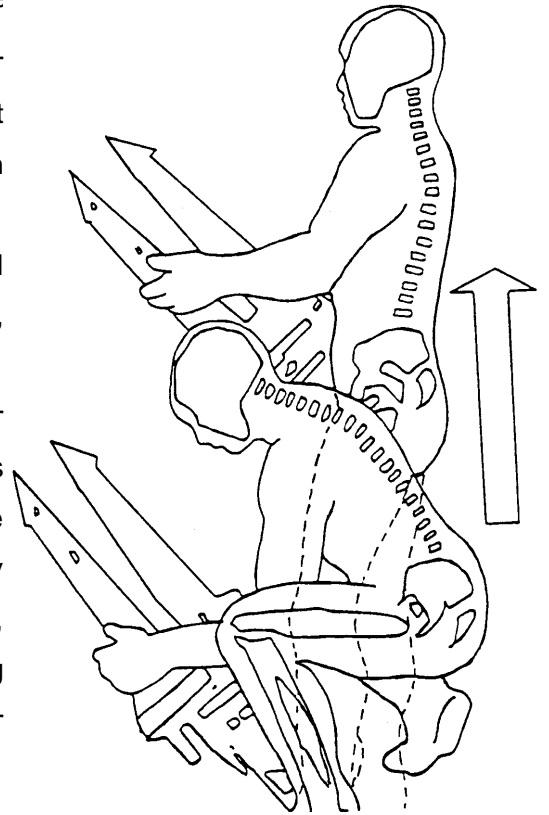

- Loads should be lowered in a reversal of the lifting techniques.

There is a serious risk of spinal or abdominal muscle injury due to incorrect lifting, and the following points detail correct lifting techniques.

TEAM LIFTING

Team lifting is carried out using the same individual techniques already described, but with team discipline and control.

- When the team is in position with respect to the load, the leader gives the preparatory order: **PREPARE TO LIFT**.
- Any rescuer not ready to lift must quickly call: **STOP**, and the Team Leader must wait until all is in order. In the absence of any such dissent, the Team Leader will give the executive order: **LIFT**.
- On this command, all rescuers lift their portion of the load by the technique already described, slowly, and in unison.
- As with the individual technique, lowering a load is the reversal of the procedure with the Team Leader using the commands: **PREPARE TO LOWER** and: **LOWER**.

CHAPTER THREE

RECONNAISSANCE

THE RESCUE PLAN

The success of rescue operations depends principally on the Team Leader organising a quick and thorough reconnaissance of the situation, and then through the appreciation process, developing a workable plan.

RECONNAISSANCE & RESCUE BY STAGES

No set of rules can be devised to give leaders specific guidance on how to tackle every job, but by proceeding in stages in accordance with a regular plan they are less liable to overlook important points and more likely to appreciate, and organise, appropriate action.

R.E.P.E.A.T.

This method of Rescue by Stages is similar to CREST (also shown below), but is more consistent with the International Search And Rescue Advisory Group (INSARAG) rescue response guidelines.

R	Reconnaissance & Survey
E	Elimination of Utilities
P	Primary Surface Search & Rescue
E	Exploration of all Voids & Spaces
A	Access by Selected Debris Removal
T	Terminate by General Debris Control

(Previously known as)	
C	Clearance of surface casualties
R	Rescue of the trapped
E	Exploration of likely survival points
S	Selected debris removal
T	Total debris removal

Reconnaissance & Survey

This is the initial activity undertaken upon arrival at a scene. It includes the resources available to the Team, including personnel, equipment, local expertise, level of training, size and complexity of task, etc. It also takes into account external factors including the weather conditions, external and subsequent threats, structure, or building, in or near the area, surface conditions, etc.

The assessment of the area, or site, that is searched for possible victims (surface and/or buried) and the identification and evaluation of resources and hazards.

Information gained from this activity should be used to compile a “master” rescue plan of the area or site, where victims, hazards, access, egress, etc. are shown.

Reconnaissance is an ongoing activity, and is not completed until the operation is finished. Reconnaissance is:

- C** Continuous
- A** Accurate
- R** Rapid, and
- T** Thorough.

It is essential that every member of a rescue team be trained in reconnaissance. In many instances the Team Leader will be responsible for a number of tasks, and personnel deployed must be capable of conducting reconnaissance and of reporting observations.

All sources should be exploited to obtain information regarding casualties, damage, and likely hazards.

The reconnaissance summary should be aimed at an accurate assessment of:

- The number and location of casualties
- Dangerous situations such as gas, electricity, overhanging walls, unsafe structural components, or anything else which may endanger rescue personnel or survivors
- Access to the casualties or task and alternate exits

- The extent and type of damage
- Appropriate services and support agencies
- Available resources, both personnel and equipment
- The time the task would take with available resources.

Elimination of Utilities

All utilities must be evaluated and controlled for the safety of all those involved. It does not involve any treatment to, or rescue of, victims, as the main need is for information at this stage. (It is expected that some rescue activities will be taking place simultaneously.)

Primary Surface Search & Rescue

Surface, and lightly trapped, victims should be removed as quickly, and safely, as possible.

Extreme care must be taken during this phase to ensure that rescuers do not become victims. It is at this stage that many of the techniques in this manual will be put to use.

Where a number of structures have to be searched, it is vital to adopt a disciplined Priority Structure Assessment (PSA). Also the hazard marking system, and the search marking system must be applied at this stage.

Exploration Of All Voids And Spaces

All voids and accessible spaces created as a result of the event must be explored for live victims.

Audible call systems can be used during this phase, e.g. line and hail search technique (as described in Urban Search And Rescue (USAR) Category 1, Awareness).

WARNING NOTE:

Only suitably trained dog units, or specially trained rescue personnel should be used in 'void' and 'space' searches.

General Rescue personnel should only enter void spaces
If visual contact with outside personnel can be maintained.

Access By Selected Debris Removal

The use of special tools and/or techniques may be necessary after locating a victim. It may be necessary to remove only certain obstructions to gain access to the victim. Information gained from the reconnaissance can be helpful during this phase.

Local knowledge and/or expertise will assist in the identification of possible victim location, and also areas where structural safety is a concern. Experts might include building wardens, survivors, engineers, etc.

Areas that have been identified by search dogs, or the use of electronic search equipment will be given priority at this stage.

It would be unusual for heavy equipment to be used during this phase.

Termination by General Debris Removal

This is usually conducted after all known victims have been recovered and accounted for.

An exception would be when information indicates the possibility of other victims located where a large amount of debris is obstructing operations. The decision to use heavy equipment during this phase must be given serious consideration, especially when there is a possibility that live victims are still in the debris.

THE APPRECIATION PROCESS

The appreciation process is a simple method of problem solving which is effective in rescue situations. It involves the logical assessment of the situation, and the reconnaissance, and results in the formation of the workable plan.

The appreciation process consists of six steps:

Step One – Define The Problem

The problem to be solved, or task to be accomplished must be clearly defined. The problem may be too large or complex to be easily tackled, and may be divided into a number of manageable elements, each with a set aim.

Step Two – State The Aim

The aim is a clear statement of what the team has to achieve in order to solve the problem. The aim must be clear, concise, achievable, and expressed in positive terms. The aim will form the mission statement in an operational briefing and should be as simple as: “To rescue the casualty from the bottom of the lift shaft”.

Step Three – Consider The Factors

Factors are points relevant to the problem that has to be solved. Some factors that may have to be considered in an operational situation are:

- Number and location of casualties
- Time and space
- Topography
- Weather
- Available resources, both personnel and equipment
- Support requirements and availability
- Communications
- Logistics
- Priority of tasks.

Each factor will lead to one or more logical deductions, so that the leader should be in a position to say: “If this is the case – then...”

Factors in an appreciation may be set out as in the following example:

Factor	The casualty's legs are trapped under a heavy steel beam.
Deduction	The rescue team must use cutting and lifting equipment to free the casualty.

Each factor should be thoroughly examined and care should be taken not to introduce irrelevant facts into the examination.

Step Four – Determine Courses Open

All possible courses that will attain the aim and that are practical must be considered in the ‘Courses Open’ segment. Only facts dealt with in the ‘Factors’ should be considered and no new material should be introduced at this stage.

Step Five – Decide On Best Course

At this stage, a choice must be made from one of the possible solutions developed by the appreciation process. If more than one workable solution is produced and the best course is not obvious, the following criteria should be applied to each:

- **Risk** — Which solution carries the least risk factor in its execution, or the consequence of failure?
- **Simplicity** — Which is the simplest course?
- **Time** — If urgency is a factor, which course can be completed in the shortest time?
- **Economy** — In the terms of resources, which solution imposes the least demand?

Step Six – Plan

The plan will result from the choice of the best course open. That is, it will be the best solution to the problem with the most advantages and the least disadvantages. The plan must be simple, and it must relate directly to the aim. When completed, the plan should be checked against the following test questions:

- Is the reasoning sound?
- Is it set out in a logical order?
- Is everything relevant to the problem?
- Has anything relevant been left out?
- Is it free of uncertainties or ambiguities?
- Is it accurate (positions, timings and so on)?
- Has the aim been kept in mind throughout?
- Can the plan achieve the aim?

CONTINUING ACTION

Having made decisions and deployed personnel, Team Leaders must ensure reconnaissance is continued with a view to allocating priorities for the further deployment of resources.

Rescuers deployed on a particular building, damaged by blast or natural causes, should make careful observation of how that building has collapsed. The art of rescue lies in being able to identify and exploit to the maximum, all debris

formations such as voids etc, which can be used to facilitate access to casualties once their whereabouts have been fixed by firm information or inference.

Attempt to locate and identify the parts of the building and especially those parts in which casualties are reported to be. This will provide a rough idea where casualties might be found in relation to the various parts of the damaged structure.

At times such as this, a leader will need to call upon all accumulated experience and training and combine them with effective decision-making.

CALLING AND LISTENING TECHNIQUES

When it is known that people are still missing, and rescuers are confronted with a major structural collapse, the casualties may be trapped within voids or survival spaces formed by the collapsing building. A 'Calling and Listening' period should be introduced — this has, in the past, saved many lives.

The leader places available team members at suitable vantage points around the area where people may be trapped, and then calls: **SILENCE, SILENCE FOR RESCUE.**

Each member, as directed by the leader calls: **RESCUE TEAM HERE, CAN YOU HEAR ME?** while the other members listen intently for any reply. If none is heard it is a good plan to tap on a wall, or on any gas or water pipe, beam etc. running into the debris, all of which are good conductors of sound, and again listen for an answer.

On hearing a reply, each listener points to the place from which a sound came, thus 'pin pointing' the position. Once contact has been established with a trapped person, it must be maintained.

At night this procedure is best done by pointing in the direction of sounds with torches. Rescuers must not be affected by peer pressure and must point to where **they** think the sound comes from.

Specialist resources such as trained dogs, heat sensors, fibre optic probes, acoustic locators and the like should be utilised where available.

If casualties are located, their recovery will entail removing debris according to:

- The location of the casualty
- The nature of their injuries (if known)
- The layout of the building
- The way in which the building has collapsed.

Where it is not possible to account for all missing people, it may be necessary to strip the site methodically. When debris has been relocated, the pile should be suitably marked.

DAMAGE TO BUILDINGS

The type of construction of a building gives some indication of how it may collapse, as a result of a blast, cyclonic wind, or earthquake. Most structures will contain voids or spaces in which trapped people could remain alive for relatively long periods. To know where these safe places may be, it is necessary to know the broad characteristics of construction types.

TYPES OF BUILDINGS

Buildings can be grouped into categories by the methods and materials used in their construction:

- Light timber framed
- Unreinforced masonry
- Reinforced concrete masonry (blockwork)
- Concrete tilt-up
- Reinforced concrete/structural steel.

Light Timber Framed

- Low rise
- Typically residential or school buildings
- Includes brick veneers.

Unreinforced Masonry

- Brick or stone construction prior to mid-1930's
- Could have concrete or timber floors
- May or may not be strengthened with steel or concrete elements.

Reinforced Concrete Masonry (Blockwork)

- Typically low-rise (up to 3 storeys)
- 1960's onwards.

Concrete Tilt-Up

- Typically industrial buildings, but also newer medium-rise residential buildings.

Reinforced Concrete/Structural Steel

- Ranges of different structural bracing systems (wall panels, moment resisting frames)
- Concrete floors
- All eras/ all sizes.

TYPES OF COLLAPSE

All buildings, when subjected to sufficient pressure will collapse in a manner that is largely dependent upon the type of construction. In most instances the floors, ceilings, and roof will collapse in large sections and not disintegrate into a large number of small sections. Cyclonic pressure is the exception to this rule.

These large sections, when they fall, will create voids. The most common types are:

- The 'V' type
- The 'lean-to'
- The 'horizontal/pancake'.

The 'V' Type Collapse

This can occur in any type of building, but is more general in the unframed type and is caused by a heavy weight of debris such as the roofing, ceiling, furniture etc. falling on, or near, the centre of an upper floor or ceiling. This causes the joists to break and collapse in the form of a 'V', thus creating two voids in which casualties may be trapped.

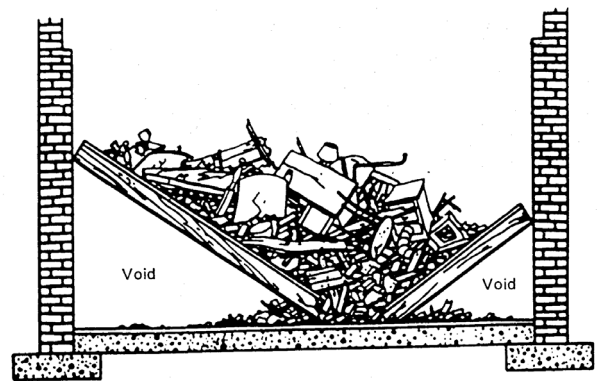

The 'Lean To' Collapse

In many cases only one of the load bearing walls will collapse, and the upper floor ceiling will 'hinge' on the remaining wall, thus creating the most common and the most difficult type of collapse to deal with. Precautions must be taken at the earliest possible moment to prevent a complete collapse by shoring or strutting.

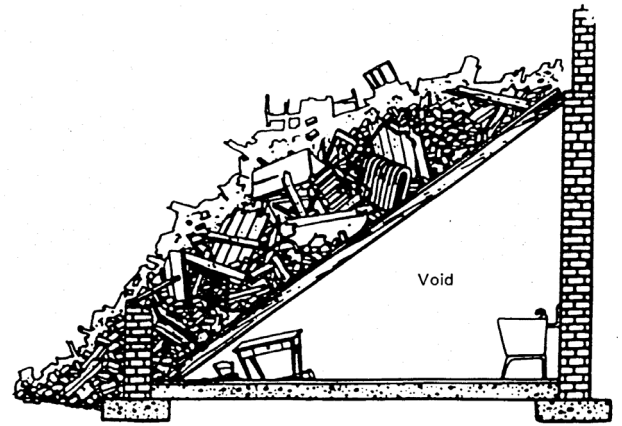

The 'Horizontal/Pancake' Type Collapse

In some cases both load bearing walls may be sufficiently damaged to permit the upper floor or floors, ceiling, or roof to pancake down into the room below.

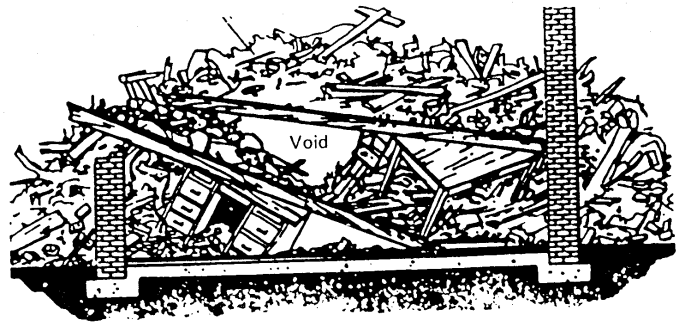

The debris will probably land on furniture or some other obstruction, thus creating a void.

Reinforcing rods and fire-distorted structural steel may create difficult and hazardous rescue problems. However, these materials will create many safe places from which people may be rescued. Rescue from framed structures may not be as difficult as from unframed, except for the fact that these buildings are usually large and multi-storied.

PRECAUTIONS IN OPERATIONS

In the interest of safety to both the trapped and the rescuers, a thorough appreciation must be made before any rescue operation is commenced. The main safety considerations are as follows:

- Do not move any debris in contact with the collapse without assessing its importance to the stability of the site.
- Always stabilise a collapse with shoring before entering a void.
- Entry and rescue procedures for confined spaces must comply with the provisions of AS2865.
- Always appreciate the forces and their possible direction of movement in all types of collapse.
- Pack and support vertically, horizontally, and laterally whenever and wherever possible.
- In all materials used, consider their strength in relation to the loads to which they will be subjected.
- Any disaster will invariably result in ruptured electrical water, gas, and sewer lines and, although these will be primarily the responsibility of the public utility, it is essential that rescue personnel be trained to deal with such problems in the initial stages.

CRUSH INJURIES

It should be remembered that casualties may be found who have suffered severe crush injuries. These people will be suffering from shock and their breathing passages may be clogged by the dust contained in the debris. Rescuers must take immediate steps to provide a clear airway for such casualties.

People trapped in debris and suffering from crush injuries need rapid and expert medical attention. These victims should be treated, if possible, before release from entrapment.

DEBRIS CLEARANCE

Two methods by which people trapped under a pile of debris can be extracted are:

- By clearance of debris, ie: by removing the debris piece by piece until the casualties are uncovered and freed.
- By the construction of tunnels and linking of voids.

If anyone survives at all, inside or under a large pile of debris after a building has collapsed, it is because some heavy timber (a floor, or other portion of the structure) has fallen or remained fixed, in such a way as to protect this person from the main impact and weight of the debris. Furniture can sometimes protect a casualty. Unless something of this kind has happened, it is unlikely that the casualty will survive. This protection may be of a very unstable nature, and, unless great care is exercised, it may collapse.

Internal collapse can be avoided only by disturbing the debris as little as possible during rescue operations, and by making sure that, as one portion of the debris is removed, the remainder is not dislodged and allowed to slide or fall.

Careful observance of these principles reduces the risk of further injury to trapped people, resulting in greater speed in the rescue operation. The ideal is "speed with safety".

When Debris Clearance Is Necessary

If no information is available regarding the approximate position of people trapped in debris, rescue can usually be effected only by total debris clearance. The essential difference between debris clearance as a rescue operation and debris clearance to clear a site is that, so long as there is a reasonable chance of recovering casualties by debris clearance, it must be proceeded with by rescue teams with unremitting effort. Rescue services must continue at work until it is certain that nobody is still alive, and that the responsible officer, according to local arrangements, decides that operations can be discontinued.

Methods Of Debris Clearance

- When debris clearance is undertaken for rescue purposes, the debris should be moved clear of the demolished building, and not merely from one part of the site to another.
- Debris can be removed by hand or by using other receptacles found on the site. In a confined space or over obstacles, it is best to form a human chain.
- It may sometimes be necessary when clearing debris, to cut a lane through it to reach a casualty. Great care must be taken in so doing, to ensure that the sides of the lane do not collapse. These can be made safe, where necessary, by a simple form of timbering or strutting

Precautions In Operations

- Exercise care in the use of edged tools in debris clearance.
- Debris close to casualties should always be removed by hand.
 - Rescuers must wear gloves.
 - Rescuers must not climb over debris during the clearing operation unless absolutely necessary.
- Debris should be withdrawn only when it is certain that no further collapse will be caused.
- Heavy equipment should be operated only at the direction of the officer in charge.
 - Movement of major debris elements must be carefully coordinated.

BUILDING MARKING

General Area Marking

In any major event, international support may be required in the form of Urban Search And Rescue (USAR) teams. It is important that information related to structure identification, conditions, hazards, and victim status, is displayed in a standardised fashion to ensure uniformity and clarity.

This system standardises team functions, worksite hazards, mapping, sketch and landmark labelling with common symbols, ensures the accuracy of search assessment markings, and documents team accomplishments.

- Common Identification System:
 - Marking
 - Signalling
- Structure Assessment:
 - Search
 - Rescue
 - Special hazards of that structure
 - Victim Location.
- Results:
 - Warning
 - Tracking
 - Continuity
 - Commonality.

It is important to identify locations within a single structure

The 'address' side of the building shall be defined as SIDE 1. Other sides of the structure shall be assigned numerically in a clockwise manner from SIDE 1.

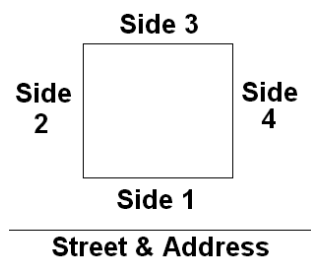

The interior of the structure will be divided into QUADRANTS:

- The quadrants shall be identified ALPHABETICALLY in a clockwise manner starting from where the side 1 and side 2 perimeter meet.
- The centre core, where all four quadrants meet will be identified as QUADRANT E (i.e. central core lobby, etc).

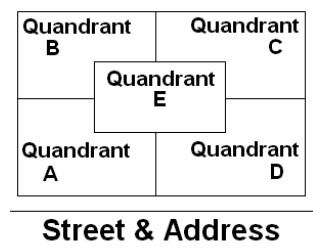

Multi-storey structures must have each floor clearly identified. If not clearly discernible, the floors should be referenced from the interior.

The entrance level floor will be designated as Level 1, then moving upward to the next floor will be Level 2, Level 3 etc. Conversely, the first floor below entrance level would be Basement 1, then Basement 2, etc.

Structure Assessment Marking

The basic symbol consists of a 1m x 1m square box at the primary access point into any compromised structure.

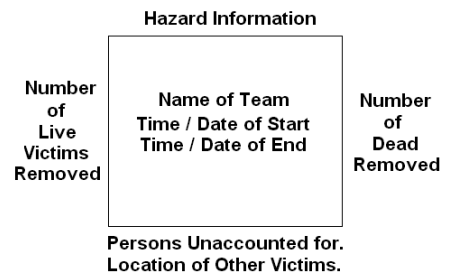

Example Marking Box

Chemicals / Gases
Requires shoring
Rats

2	Anytown CD Rescue Team	7
	21 / 11 0730 Hr	
	22 / 11 1730 Hr	

12?
2 Dead in Elevator

Example Completed Marking Box

Chemicals / Gases
Requires shoring
Rats

2	Anytown CD Rescue Team	7
	21 / 11 0730 Hr	
	22 / 11 1730 Hr	

12?
2 Dead in Elevator

VICTIM MARKING

An easy way to understand the USAR marking system is to place it in a scenario context.

Potential Victim in area

Scenario:

*A five-person search team arrives at a collapsed structure. A man standing outside the building informs the team that it is his apartment block, and says that his wife and son are still inside on the second floor, in what the team would identify as Quadrant A. Initially, a **V** would be placed in the area to identify a potential victim location, due to the intelligence received from the husband.*



Potential Victim Location

The search team would then conduct a technical search to locate the victims. Assuming they get some form of visual or audible confirmation, an arrow would be added to indicate the direction of the victims.



Confirmed Victim(s) Location

Assume the woman is alive and her son and one other person in the area are dead.

*Information regarding the live and dead is added below the **V***

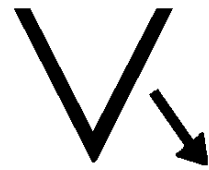

L - 1 (Number of Live Victims)
D - 2 (Number of Dead Victims)

Confirmed (Dead) Location

Marking for the dead victims only, that are still on site is:

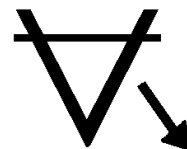

D - 3
(Number of Dead Victims)

Extricated Live Victim(s)

*Once the woman was recovered, and only the dead remain, the information below the **V** is modified by putting a line through the Live Victim information, as well as a line through the **V**.*

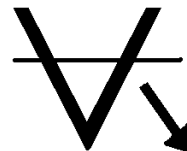

~~L - 1~~ (Number of Live Victims)
D - 2 (Number of Dead Victims)

Extricated Dead Victim

*Once all victims (live and dead) have been removed, then the entire **V** marking would be encircled.*

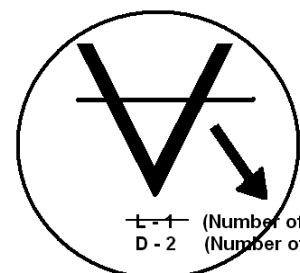

~~L - 1~~ (Number of Live Victims)
D - 2 (Number of Dead Victims)

OTHER MARKINGS:

General cordon markings (marking tape, cordon, banners, flagging etc)—to be used for small, defined area. They can be enlarged to include other non-buildings (i.e. bridge, dangerous zones, security, etc). Large areas may require barricades/fences/patrol/etc.

Operational Work Zone

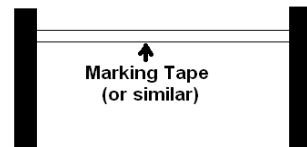

Collapse / Hazard Zone

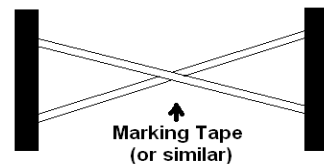

Facility

Iconic flags, banners, balloons etc. (must identify team identity, team medical facility, team CP).

Vehicle

Vehicles must be marked with team name and function (flag, magnetic sign etc).

Team and function

- Response team identified by uniform, patch, etc.
- Personnel – the following positions should preferably be colour-coded, with plain text, on armbands, helmets, etc.
 - Management position(s) – white
 - Medical position(s) – red cross / red crescent
 - Safety / Security position(s) – orange.

THE DEAD

Identification And Removal

Although identification of the dead is a Police responsibility, routine procedures may not be feasible in a major disaster. Police Disaster Victim Identification (DVI) teams, located at various points around the country will be deployed to a disaster area and may require Civil Defence Emergency Management assistance.

- In general, do not remove bodies from the position in which they were found without the agreement of the Police.
- Nevertheless, a rescuer may be justified in moving a body:
 - When rescuers would be put at risk if they had to re-enter the damaged building or structure where the body is located.
 - Where it is necessary in order to reach an injured person.
 - Where the body itself might be affected by flooding, fire, or imminent collapse of a building or structure.
- The exact position in which a body is found may be critical to the identification of that person, particularly if there is extensive mutilation.
- Where bodies do not have to be removed from the building or structure for reasons of safety, make a notebook entry of the location of the body and advise the Police as soon as possible. If possible, do not leave the site until the Police have arrived.
- Where, in the interests of safety, it is considered that bodies should be removed from the exact location of where the body was found, then the person finding the body must collect all necessary information (including any identity obtained from survivors, and personal belongings found with the body). This should be recorded and attached to the body.

Suspicious Circumstances

- If you are in any way suspicious as to the cause of death (suspecting either murder or suicide), do not disturb the body and surrounding area, but record, secure, and then notify the nearest Police.
- Where there is danger of further damage to the body, (by fire, flood, or collapse of the building or structure, or danger to rescue workers and Police), then the body may be removed to a safe place which can be secured.
- Give the Police all vital information (covering the location and position of the body, cause of death, suspicions, circumstances, personal belongings, etc.) included in a full report as soon as possible.
- Photographic records of the original position and surrounding area would be most beneficial, where available.

Conduct At The Scene

- In the presence of death, everyone should be respectful, subdued, and orderly.
- There should be no attempt at humour.
- Although survivors may be shocked when seeing their relative or friend covered, indicating death, *DO* cover a severely mutilated body.
- Otherwise, treat a body as you would a low priority casualty.

CHAPTER FOUR

ROPES, TAPES, KNOTS & LASHINGS – GENERAL INFORMATION

INTRODUCTION

During a rescue operation, a variety of techniques involving ropes, tapes, knots and lashings may be required.

IDENTIFICATION

A system of marking each end of a rope for identification of length, and with a reference number to the rope history card, is recommended.

Colour Coding can be used to quickly identify ropes, and should be located at each end of the rope. The suggested colour coding is:

- **GREEN**—OK to use for all activities.
- **RED**—not suitable for 'life' work.

Discard damaged rope immediately.

If faults are found during any rope inspection, immediate steps must be taken to rectify the problem(s) in accordance with Standard—AS4142.3 (or EN1891).

RECORD SYSTEMS

All ropes should be clearly and permanently identified and a record kept of individual items, their usage, inspection, and maintenance.

Suggested headings for a record system are as follows:

- Identity Number
- Item Description
- Purchase Date
- Usage Dates
- Description of Usage
- Inspection Date

- Inspected By: (name)
- Maintenance Carried Out
- Signature.

ROPE

Rope is one of the most important tools of the rescue team. Rescuers will use a range of rope types for specific applications. All types have their advantages and disadvantages, but provided the rescuer has thorough knowledge of the characteristics and capabilities of each type, all will give valuable service provided they are appropriately cared for and maintained.

Whilst it is accepted that the Standard has not yet been adopted by all rescue services, it is strongly recommended that only synthetic fibre, Kernmantel, and static ropes which comply with AS4142.3, be used for life rescue purposes.

TYPES OF ROPE

The ropes in common use with rescue teams are:

- Synthetic fibre rope
- Climbing tape
- Natural fibre rope
- Flexible steel wire rope (SWR).

TERMINOLOGY

For the purpose of this manual, the following terms are used in reference to rope and rope management. Other terms may be used in specific organisations.

Anchoring

Fastening a rope to some suitably secure object.

Belaying

Controlling a safety rope attached to personnel or equipment as a backup in case of primary system failure.

Bight

A simple bend in which the rope does not cross itself.

Breaking Force

The averaged ultimate breaking point of rope.

Expressed in kilograms (kg) or in kilo-Newtons (kN) following rigorous testing.

Also referred to as Breaking Strain or Mean Breaking Load.

Hauling

The act of pulling on a rope.

Half-Hitch

The closed loop on a rope; a simple fastening of a rope around some object by winding and crossing one turn so that one section of the rope bites on the other without actually knotting the rope.

Kernmantel

A style of construction of synthetic fibre rope, consisting of a core (kern) and a sheath (mantel).

Loop

A simple bend in which the rope crosses itself.

Marrying

Twisting the running end around the standing part, in the same direction as the lay of the rope.

Mousing

Tying a piece of cord or wire across the jaws of a hook to prevent a rope or sling from jumping out of the hook.

Parcelling / Edge Protection

Wrapping a section of the rope to prevent chafing against some object.

Paying Out / Easing

Reducing the tension on a rope so as to allow it to pay out or slacken.

Reeving

Threading a rope through pulley blocks.

Round Turn

One complete turn of a rope around a spar or another rope.

Running End

The free or working end of a rope.

Safe Working Load (SWL)

The maximum working load that should be applied to a rope.

This is consistent with the factor of safety recommended for the conditions under which the rope is to be used (the breaking strain divided by 10).

Standing Part

The part of the rope which is taking the load or which is static.

Tail

The short length of rope or tape (approximately 100mm) that extends past the completed knot.

Whipping

Binding the end of the rope with twine to prevent unlaying or fraying.

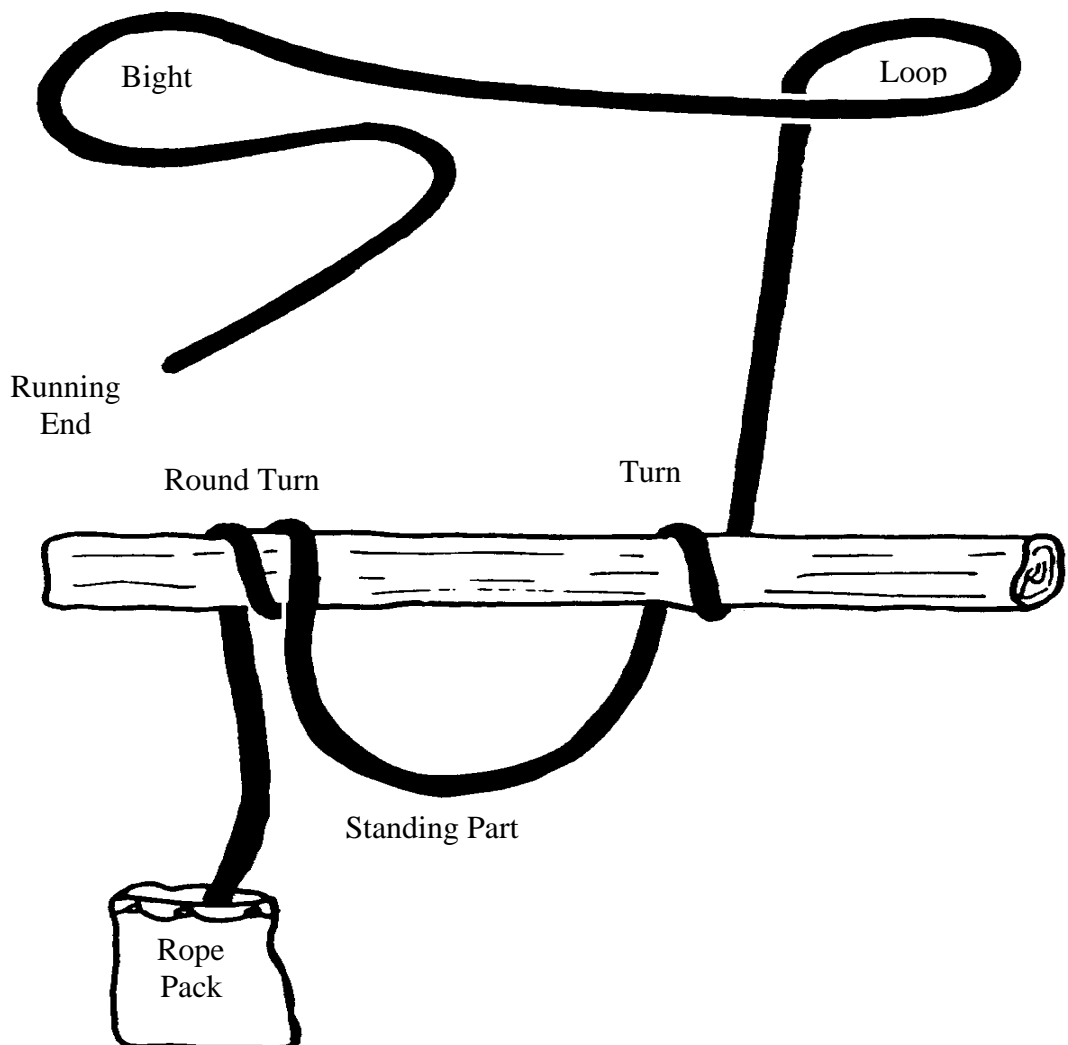

ROPE PACKAGING

There are a number of techniques suited to the packaging of rescue ropes, including:

- Stuff Sacks
- Chaining
- Hanking
- Coiling

Stuff Sacks

These are the preferred method of storage and carriage for long length ropes, and as the name implies, the rope is merely stuffed into the pack and gently tamped down. The sacks can be simply bags, or packs with straps for carriage to the site, and while they are expensive, rucksacks are best for most operations.

Chaining

This is a technique that can be used for ropes of any length, which reduces the final length of the packaged rope. This is useful when washing ropes in a washing machine or for operational packaging. The rope can be chained as a single length, or doubled and then re-doubled as shown.

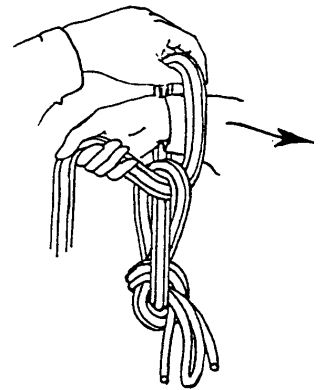

Hanking the Rope

This is also effective for 50m or shorter lengths, and is quite effective with doubled ropes.

- Grasp the rope about 2 metres from one end and at full arm span distance, form bights in the rope, laying them on alternate sides of your hand.

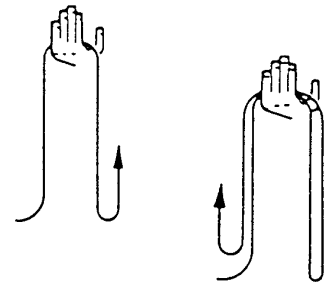

- Continue until 4 metres from the other end.

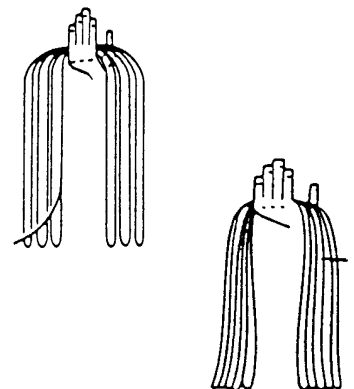

- Tie the next 2 metres around the bundle of rope just beneath your hand working up towards your hand.

- With the remaining 2 metres, push a bight through the hole where your hand was (between where tied and the doubled rope bight), invert it over the head of the hank and pull tight.

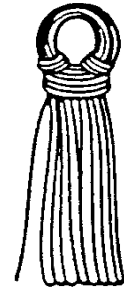

To use, undo the bight and hold the hank

- Lay on ground
- Pull out as required.

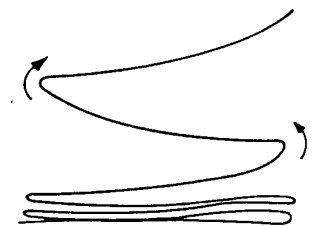

Coiling

Ropes of up to 50m in length can be rapidly coiled and finished off with turns. It should be noted that coiling will severely kink a rope, and that hanking is preferred to coiling at all times.

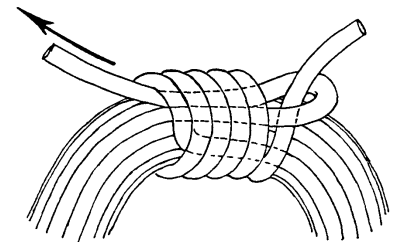

The coil can be secured as shown.

ROPE PACKAGING (CARRYING)

Sacked ropes are easy to carry where the sack is fitted with rucksack straps, and coiled or hanked ropes can be carried as shown.

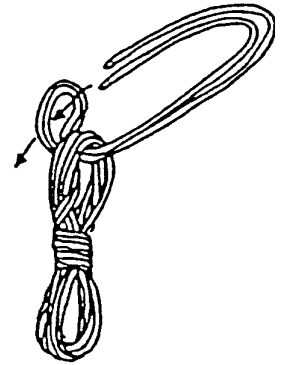

Chained ropes can be carried in packs, or draped over the shoulder.

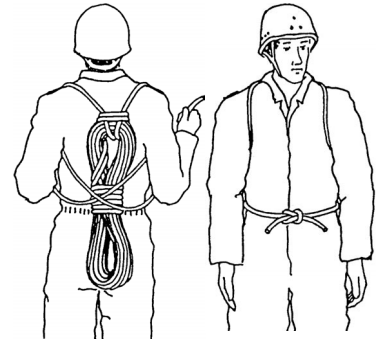

CLIMBING TAPES

Tape or webbing is one of the most versatile materials available to rescuers. It is used as tied, or sewn, slings, and its applications are limited only by the imagination of the rescuers. Some examples of the use of tape slings in disaster rescue are:

- Suspension of blocks from derricks
- The 'hinge' in a ladder hinge
- Anchorage of a mechanical descent device.

Tape slings are used to make improvised harnesses, casualty support systems, anchor attachments, and to link rescue tackle together. Tape is normally tied off in slings with circumferences of 1200mm and 2500mm, referred to as 'single' and 'double' tape slings. The material is very versatile, and can be used to form slings of any length for specific purposes.

Only tape specifically made for rescue, climbing, or caving by recognised equipment manufacturers should be used for vertical rescue.

Construction

There are two broad design categories of tape—flat and tubular. Both types are actually flat in appearance. However, if tubular tape is viewed in cross section, it forms a hollow tube. Standard tubular tape is normally the strongest and most flexible form, and is therefore recommended for vertical rescue.

Tape is woven in many different ways, and the characteristics that can be effected by the style of construction are: strength, elongation, abrasion resistance, and ultra-violet resistance. All of these factors are affected by the fibre used and the weave tension in particular. While a tape with a very tight weave will be strong, knot retention and suppleness will be poor. Obviously, a good rescue tape is a compromise of factors.

Size

Polyamide is sized by a flat width, with 25mm and 50mm being the most commonly used sizes. Smaller tape sizes may be used for some very specialised techniques, but are not suitable or safe for general vertical rescue work.

Abrasion

Under certain circumstances, tape is liable to abrade or wear more rapidly than rope, and it has no sheath for extra protection. Additional attention must be paid to wear or friction areas, and tapes must be discarded when doubt exists as to its safety.

Tape Strength

For vertical rescue operations, only tape with a minimum rated strength of 1500kg should be selected.

The Use of Tape

As previously stated, tape is normally used in the form of sewn or tied slings for all manner of anchorage tasks, improvised harnesses, casualty slings, and other attachments. Where tape is tied to form slings, the only safe knot is the Tape Knot.

The team equipment should include various sized slings. This is the preferred method as strength loss due to knotting is minimised by the use of a single sling. As a very rapid means of joining a large or extra large sling, one or more tapes can be joined by means of a Karabiner, or preferably by untying the slings and joining them into a large sling with Tape Knots.

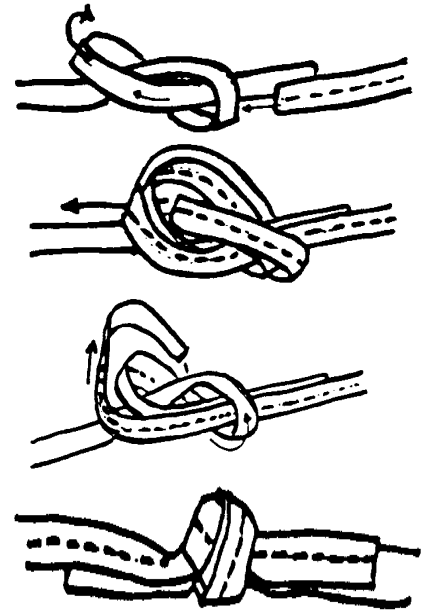

WARNING NOTE:

Always check Tape Knots before using slings.

Care and Maintenance

Tape must be treated in exactly the same manner as synthetic rescue rope, subject to all normal inspections and safety procedures and recorded in the rope record system.

Safety

The following safety points relate to tape:

- When slings are carried on operations, they should preferably be carried on the harness, or diagonally around the neck and under one arm. (Many rescuers carry spare slings around their necks, and it must be recognised that this is a

potentially lethal practice; should the rescuer fall, the loose slings can snag, resulting in serious or fatal injury.)

- Knots must be regularly checked for signs of overstrain or loosening, and properly retied, or cut and retied, where necessary, with minimum tails of 100mm.
- All tape must be regularly and carefully inspected for signs of damage or abrasion, and where damage is suspected, or serious abrasion has occurred, the tape must be withdrawn from service. Where a sling has been subjected to a severe loading, it may be seriously damaged but the damage may not be obvious. ALL SUCH SLINGS MUST BE DESTROYED.

WARNING NOTE:

Home sewn slings are totally unsafe and have no place in the rescue environment.

Tubular tape is preferred for rescue as it is less prone to damage on an edge or rough area than is flat tape.

Tape must have the same care as rope. It should be protected from abrasion, contamination, friction heat, and shock loading, and inspected before, during, and after every use.

FLEXIBLE STEEL WIRE ROPES (SWR)

SWR's have many rescue applications, including heavy haulage and lifting, and structural demolition. The most commonly used SWR's are those fitted to vehicle and hand operated winches.

Safe Working Load (SWL)

In Rescue, we treat steel wire rope as we do rescue rope and use a safety factor of 10:1 eg: Mean Breaking Load divided by 10 = SWL.

Steel Wire Rope is manufactured to a tested **Mean Breaking Load (MBL)** which should be clearly displayed on the end plates of the rope drums or an attached rope identification label.

The **safe working loads** for these ropes can be calculated by dividing the MBL by a **safety factor of 10** which is considered to be an appropriate factor for rescue purposes.

$$\frac{\text{Mean Breaking Load (kg)}}{10} = \text{SWL}$$

Construction

Steel wire rope consists of a number of strands (normally six) with a fibre core.

Each strand consists of a number of steel wires – the most common form of construction being 6/19, indicating six strands, each of nineteen steel wires and with a fibre core.

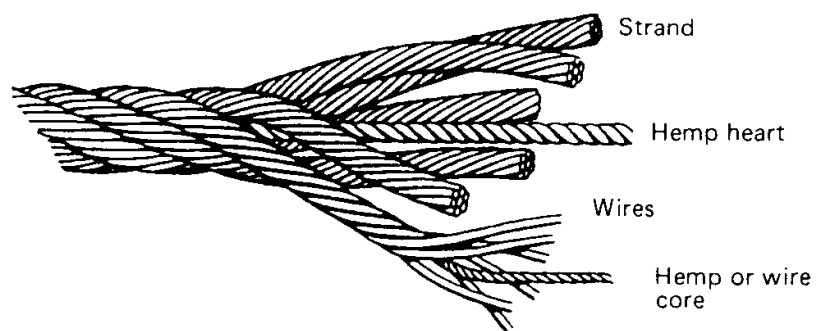

During manufacture, wires and strands are coated with lubricant to prevent corrosion and friction in the rope, or they are galvanised.

Precautions in Operations

Wire ropes should not be bent sharply at any point. As a general rule the smallest diameter around which a SWR should be bent should be approximately **ten times the diameter of the rope** – anything less than this will cause damaging and uneven stresses on the rope: eg: 10mm rope needs a 100mm bend.

Inspection of Steel Wire Rope

SWR's should be regularly inspected in the following manner:

- Check the shackle used with the rope to see that it has not suffered distortion or strain and that the shackle pin is in good condition; easily screwed home by hand.
- Examine the thimble and the splice. The splicing cannot be seen as it is covered by the wire binding or 'serving', but if the binding is loose or shows signs of bulging, it is probable that the splice is starting to come undone.
- Wearing gloves, work along the rope, a hands breadth at a time, checking that it is reasonably round, i.e. it has not been flattened or suffered distortion which causes the wires to open and thus weaken the rope.
- Look for broken wires. A broken wire in a rope should always receive prompt attention. Delay may lead to serious accidents and will certainly cause damage to other wires. The method often used to deal with a broken wire, nipping the wire off using pliers is not entirely safe as a small jagged end is left. To save time and trouble, simply bend the wire backwards and forwards with the fingers until it breaks, or, in the case of a short end, use a piece of wood to bend the wire. In this way, the wire breaks inside, instead of outside the rope, and the end is tucked away between the strands where it can do no harm.
- Look for kinks. When a rope has been kinked, the kink may pull, but when the rope is stressed, and although it may appear reasonably sound, the structure of the rope has been distorted and damaged. The length affected by the kinking may only be small, but this becomes the weakest part of the rope. The presence of a kink is best detected when the rope is lying slack on the ground. Rope of any sort found defective should be labelled and placed apart from good ropes until they can be examined by a competent person.

Storage of Steel Wire Ropes

Wire ropes should be stored under cover in a clean, dry place and in such a manner that no part touches the ground. They must never be stored by laying on concrete or other floors, as these have an adverse effect on the steel. Regular inspection for the presence of corrosion is necessary.

VERTICAL LIFT KNOT

The Vertical Lift Rescue Knot is used to raise or lower casualties in a vertical position, usually in a confined space such as a shaft. Originally used to rescue workers overcome by gases in sewers, it is sometimes called the Sewer Knot.

The feature of the knot is that it can be tied in the bight of the rope without using the ends. This in turn means that the two ends of the rope are available to haul on, and to keep the casualty central in the shaft. The significant safety feature of the knot is that there is no "knot" to slip undone

Remember at all times the comfort of the casualty must be taken into account and padding should be used as necessary

- The bight of the line is taken behind the casualties neck, run down over the arm, behind the buttocks, and up through the legs. The line is then brought back up the front of the body and laid over the shoulder.

CAUTION: Make sure that the ropes do not cross over between the legs.

- A loop is passed under the first rope so that the arm can be passed through the loop. The rope is now behind the back and inside the rope at the neck of the casualty. An alternate method passes the rope over and back through, and placing the arm through the loop, twisting the lines along the side of the body.
- The rope is adjusted to be securely fitted to the casualty. Starting at the neck, adjust the ropes and padding on both sides of the body.
- A Figure 8 on a Bight, using both ropes, is tied behind the casualty's neck to complete the knot. The lowering line is then attached with a Rethreaded Figure 8. The tails of the Vertical Lift Rescue Knot can then be used as guide-lines, or secured out of the way.

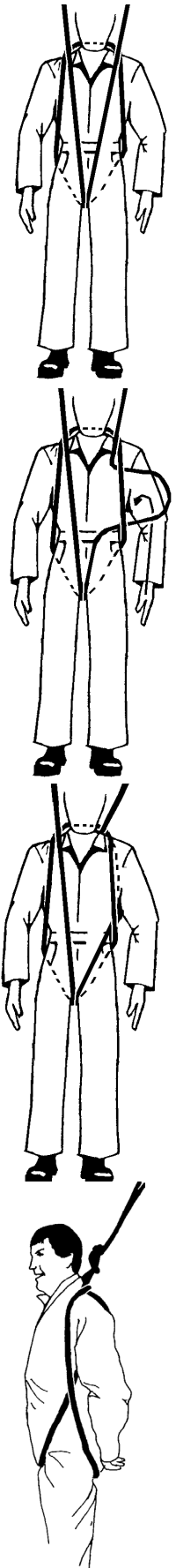

CHAIR KNOT

- Initially loops should be of equal size (knot placed in the centre of the chest and arms extended).
- The casualty is then slung, one loop under the arms, and one under the knees.
- The knot should be midway between nose and knees.
- The Chair Knot may also be used as a stretcher sling, by forming a Chair Knot complete with Half Hitches in the centre of a 12 metre rope.
- The sling is attached to the stretcher handles by means of Half Hitches, and adjusted.
- The main lowering or hauling rope is normally attached to the Chair Knot by forming a Rethreaded Figure 8 knot and tying this into a Double Figure 8 knot that is tied into the Chair Knot lines (as is done with the Vertical Lift knot).

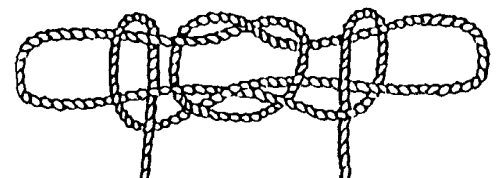
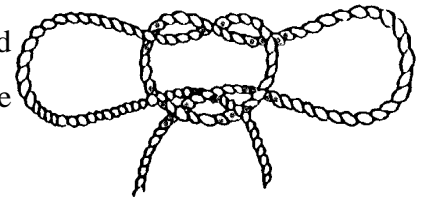

Chair Knot – Alternate Method

The Double Figure 8 on a Bight (Anchor 8 / Industrial 8) can be used in place of the Chair Knot. In certain circumstances (e.g. using synthetic rope, or rope of small diameter) this may be preferred, due to non-slip features of this knot.

LASHINGS

Lashing are mainly used to secure two or more poles firmly together. The form of each type can best be understood by a careful study of the diagrams and appended explanations.

Terminology

All poles or timbers in a vertical attitude or which will be raised vertically are known as **standards**, while those used horizontally are referred to as **ledgers**.

Square Lashing

Used to lash together two poles that touch and cross at right angles.

- Start with a Clove Hitch around the standard, below the ledger, marrying the ends.
- Take the married ends up and around both standard and ledger as depicted by the arrows.
- Repeat this circuit three or four times, working inwards on the standard until the gap is filled, keeping the rope as taut as possible.
- Take three or four turns around the whole lashing between the poles, draw taut, and finish with a Clove Hitch on the ledger.
- The square lashing shown is shown from the back.

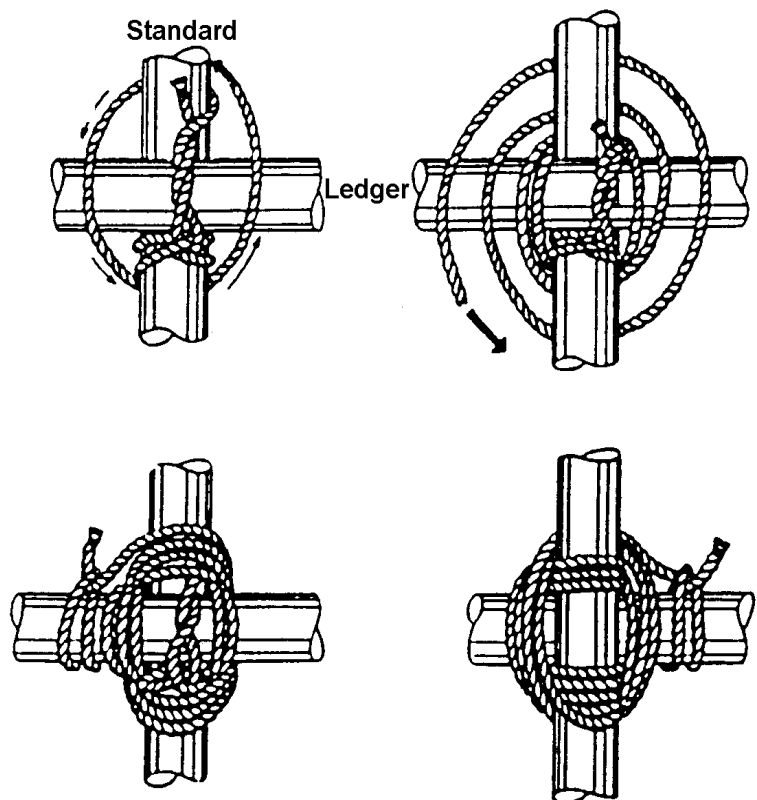

Diagonal Lashing

This is used to lash together two poles that touch at an angle, especially when their mode of use may cause them to spring apart.

- Start with a Timber Hitch around both poles horizontally, then take four vertical turns and draw taut.
- Take four horizontal turns and draw taut.
- Finally, put four turns over the lashing, between the poles, draw well taut, and finish with a clove hitch.

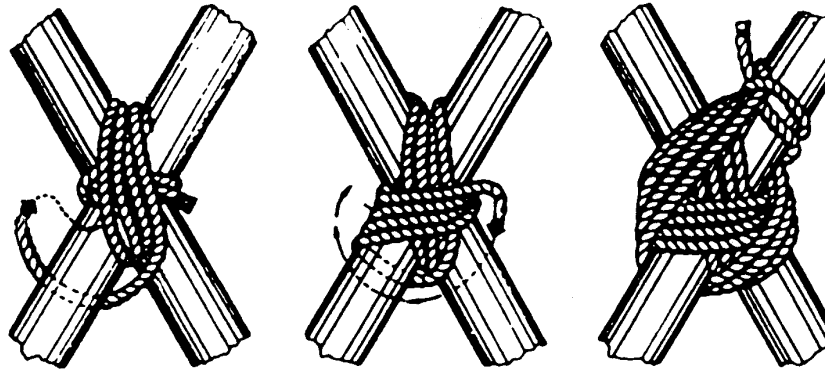

Round Lashing

This is used to lash together two poles that lie parallel to each other.

- Insert spacing pieces about 50mm wide between the poles.
- Start with a Clove Hitch around one pole and continue with 6 – 8 close turns around both poles, travelling upwards.
- Make two or three turns around the lashing and secure with a Clove Hitch on the opposite pole to the beginning of the lashing.
- Do not remove the spacing pieces until the lashing is completed.

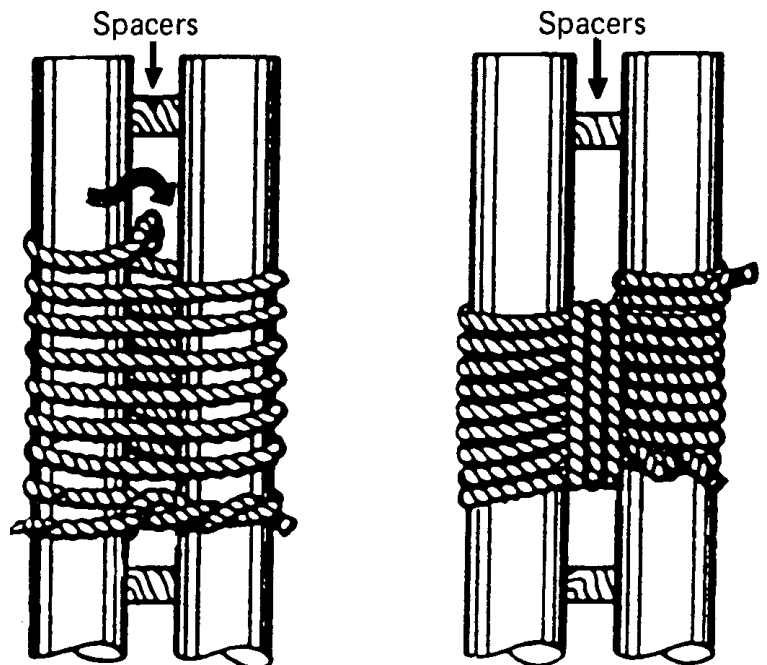
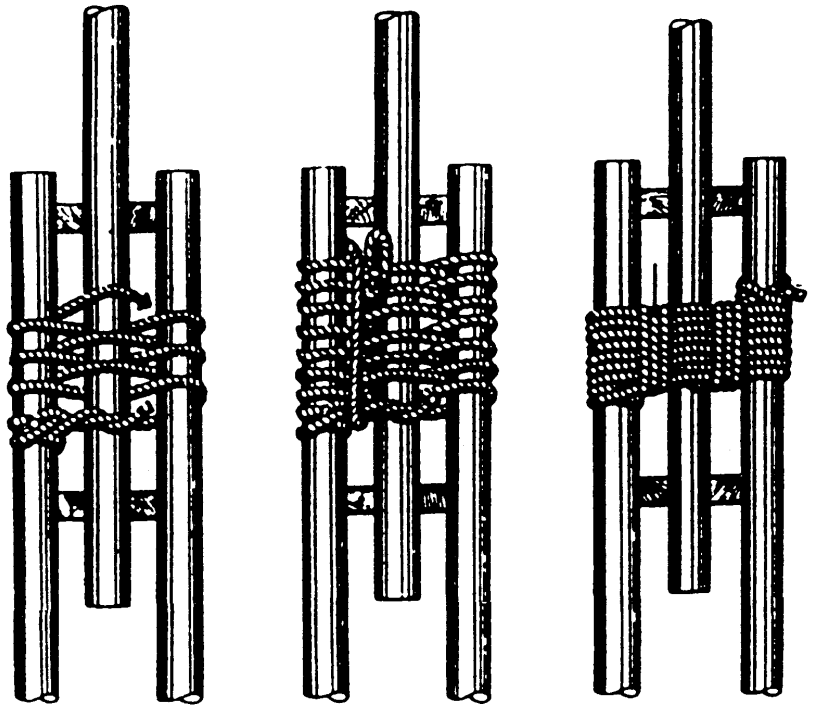

Figure of Eight Lashing

This is used to lash three parallel poles together, as may be necessary to form a tripod.

- Insert spacing pieces about 50 mm wide between the poles.
- Start with a Clove Hitch around one of the outside poles.
- Working upwards all of the time from the first Clove Hitch.
- Continue lashing in Figure 8 fashion for 6 – 8 turns.
- Make two or three turns around the lashing between the first and second poles.
- Then make two or three turns around the lashing between the second and third poles.
- Finish with a Clove Hitch on the opposite pole to the beginning of the lashing.
- Remove the spacers.



CHAPTER FIVE

SYNTHETIC ROPES - KNOTS

CONSTRUCTION

The manufacture of synthetic fibre rope commences with a chemical process that produces the raw material, such as Nylon or Terylene. The material is then melted and extruded through holes in a metal disc to produce long and fine **filaments**.

The filaments are then stretched and cooled, with the amount of stretch determining some subsequent rope properties. In basic terms, higher stretching during filament manufacture will result in a rope with higher tensile strength and lower stretch in use.

These filaments are then bunched to form **multi-filament yarns**. Synthetic rope should be of 'continuous filament' or 'multi-filament' construction, with each filament being a continuous length throughout the rope. It is generally easier to detect a continuous filament rope, as it will be smooth and shiny in appearance, without the 'hairy' appearance of 'stable' or short filament ropes.

The multi-filament yarns are twisted to form **primary strands** and twisted together again to make **plied strands**.

The plied strands are then laid together and encased in a **plaited sheath**. Ropes of multi-filament kernmantel construction are manufactured from Polyamide fibre with a limited stretch factor and high static strength making them ideal for rescue purposes.



HAWSER LAID



BRAIDED



MULTI—PLAIT

POLYAMIDE (NYLON)

There are several different types of Polyamide. The two most commonly used in the manufacture of rope are Nylon 6 – also known as Perlon, and Nylon 6.6.

ADVANTAGES of Polyamide over Polyester (Terylene) and other rope filaments are:

- Polyamide is about 10% stronger than Polyester.
- Polyamide has excellent shock absorption characteristics.
- Nylon 6.6 has one of the highest melting points at around 260 degrees centigrade.

DISADVANTAGES of Polyamide are:

- It may lose up to 15% of its strength when wet (and regain this loss on drying out).
- It is readily affected by contamination by acids.

Polyamide ropes are commonly used in life support application, including rescue, climbing, and caving.

KERNMANTEL CONSTRUCTION

The term kernmantel comes from a German word *Kern* meaning core, and *mantel* meaning sheath.

The kernmantel style of construction therefore consists of a kern or core of filaments designed to sustain the greater part of the load. This core is covered by a woven or braided sheath which supports a lesser portion of the load, but which provides protection for the core against abrasion, dirt, and sunlight (ultra-violet light).

This construction style provides a rope that is strong and resistant to damage, yet is light and easy to handle. These ropes also tend to be highly resistant to spin or twist.

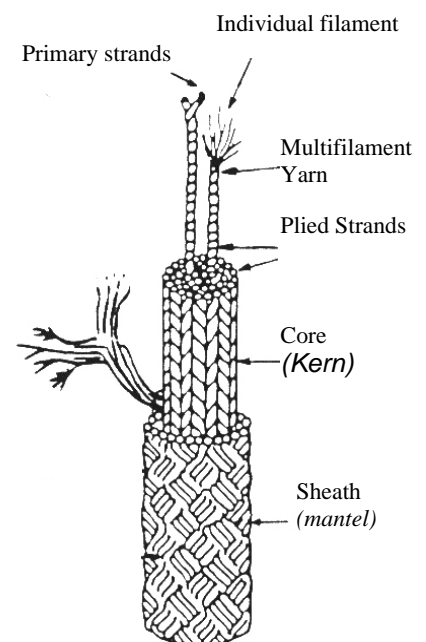

STATIC KERMANTEL ROPES

Elongation

A static rope is one designed with low elongation characteristics. These ropes normally elongate around 3% under one person's body weight, and not more than 10 to 20% at ultimate breaking point.

Elasticity

The stretch of a static rope is normally attributable to the elasticity of the rope filaments. Static ropes have poor shock absorbing qualities, and any shock loading subjects the rescuer's body, the equipment in the system, and the anchor system, to high impact forces.

Strength Vs Handling

Static ropes tend to have thicker sheaths for greater core protection. The increased sheath contributes more to the overall rope strength, but results in a stiffer rope with poorer rope handling characteristics.

ADVANTAGES of static ropes are:

- Low stretch
- Resistance to abrasion
- High tensile strength

DISADVANTAGES of static ropes are:

- Poor capacity for shock absorption
- Stiffer handling and knotting.

WARNING NOTE:

All ropes used in a rescue system must have identical characteristics to avoid unequal stretch and load reactions.

CHARACTERISTICS OF A SYNTHETIC FIBRE STATIC RESCUE ROPE

The criteria for synthetic fibre ropes are laid down in Australian Standard AS4142.3— 1993, (Fibre ropes—Part 3 Man-made fibre rope for static life rescue lines):

- Minimum diameter 11mm
- Static kernmantel construction
- Minimum rated strength 3000kg
- 100% Polyamide (Nylon)
- Spin resistant
- Abrasion resistant
- Good handling and knotting properties
- Maximum 3% elongation at 80kg load
- Maximum 10% elongation at 375kg load
- Maximum 20% elongation at 3000kg load
- Contrasting core and sheath colours
- Coded with an identification tape in the core.

CARE AND MAINTENANCE

The following points should be observed:

- Avoid cutting a rope unless it is essential to do so. If it is necessary, ensure the cut end is heat sealed as soon as possible to prevent fraying. (As a temporary measure, tie a Figure 8 knot near the end of the rope or secure it with adhesive tape.)
- Do not leave knots in a rope as they considerably reduce its strength by seriously damaging the fibres.
- Always use proven knots and fastenings for ropes. Sharp bends or knots can overload elements of the rope. Swayed eyes at rope ends should be avoided.
- Use the correct size sheave in pulleys. Any attempt to force a thick rope through a smaller pulley will cause damage.
- Avoid shock-loading, sudden jerks or violent stress on the rope.
- Avoid stepping or walking on the rope as this will force damaging grit and dirt into the fibres.
- Avoid passing a rope over a sharp edge or rough surface. If it is necessary to do this, protect the rope with sacking or other material.

- Ropes that have been hauled through mud, sand, or grit, should always be cleaned after the work has been completed. This is best managed by washing the rope in fresh, running water and following any manufacturer's recommendations.
- Do not dry ropes in front of a fire or other heat source. Spread the rope on a ladder, laid horizontally off the ground in a cool, shady area to enable the air to circulate freely around the rope.
- Store ropes under cover, off the floor, preferably in racks, in a place free from extremes of temperature and out of contact with any contaminating materials.
- Damaged or defective ropes must be appropriately labelled and removed from service immediately. Details must then be entered on the rope history record card.
- Ropes should not be exposed to direct sunlight for prolonged periods as the fibres will degrade due to ultra-violet radiation. If a rope has to be stored in an exposed location, cover it with a tarpaulin or some other form of protection.
- Ensure no contact is made with contaminants such as grease, oil, petrol, hydraulic fluid, acids, alkalis, and chemicals.

WASHING ROPES

Ropes should be washed when dirty to reduce the effect of grit abrasion on both the rope and the equipment. The rope can be chained to prevent tangling.

Polyamide ropes can be washed in a washing machine, but the machine must be set on the cold or warm setting (never on hot) and no washing agents or fabric softeners should be used.

Where help is needed to clean a particularly dirty rope, refer to the rope manufacturer's specifications.

The washed rope can be pulled under a very slight tension through an in-line descender to remove excess water, and the rope dried in a cool shady area with good ventilation.

INSPECTION

WARNING NOTE:

Load testing of ropes is not recommended as a safe practice.

All ropes should be inspected before, during, and after use. The inspection should be carried out by **visually examining** the rope and by thoroughly **feeling** the rope.

Visual examination should check for the following signs:

- **Discolouration Of The Filaments:** Any changes in the original colour of the rope filaments could indicate contamination by chemicals.
- **Melting:** Any smooth areas could indicate the rope has been damaged by heat fusion.
- **White Filaments:** Where the sheath has been damaged, the white core filaments may protrude.
- **Size Uniformity:** The rope may be damaged by mechanical impacts or over stressing. This may be evidenced by a change in the obvious shape and diameter of the rope.
- **Abrasion:** Excessive signs of abrasion may indicate the breaking of a sheath bundle and localised weakness.
- **Stiffness:** Any inconsistency in the texture of a rope and its stiffness. A bight of rope should have uniform radius around the bend, and inconsistencies may be soft spots that indicate core damage.

Thoroughly feeling the rope should check for these additional signs:

- **STIFFENED FILAMENTS:** This indicates possible overloading or contamination.
- **CHANGES IN DIAMETER:** Depressed irregularities in the rope diameter (soft spots) may indicate core damage, while increases in the apparent

diameter may be due to severe twisting of the core, or the protrusion of core filaments through the sheath.

- **Contamination:** Presence of dirt or other materials.

RETIRING A ROPE

It is currently impossible to properly test a rope without destroying it, and the decision to retire a rope from service must therefore be based on careful inspection by a confident Rescue Instructor. The following guidelines will assist in deciding when to retire a rescue rope:

- **Abrasion.** As a general rule when more than half of the sheath yarns are broken, or the abrasion 'fuzz' stands out from the sheath more than 25% of the rope diameter.
- **Loading.** Where the rope is known to have sustained a shock loading or to have been overloaded, it should be retired.
- **Contamination.** Unless the material with which the rope has come into contact with is harmless, it should be considered as contaminated.
- **Texture.** A lack of uniformity of texture such as soft or hard spots.
- **Diameter.** Variations in the observable diameter of the rope such as soft or hard spots.
- **Sheath Protection.** Where the white core filaments are visible through a hole in the sheath, or where the core protrudes through the sheath as a white filament 'puff'.

Whilst some services may have a policy on the life or limit of use of a rope, the bottom line with regard to rope retirement must be:

IF IN DOUBT, THROW IT OUT.

RATED STRENGTH AND SAFE WORKING LOAD

For synthetic fibre rescue rope only, it is recommended that a safety factor of 10 be considered as an appropriate margin of safety to reflect ageing, environmental effects, and less than ideal usage; including the tying of knots in the rope during its use.

Rope Diameter (mm)	Breaking Force (kg)	Safe Working Load (kg)
11	3000	300
13	3600	360
16	4500	450

WARNING NOTE:

Users must ensure that equipment used in conjunction with the rope is suitable for the task it is required to perform.

POLYAMIDE DYNAMIC CLIMBING ROPES

These ropes are exclusively made from Polyamide, constructed in kernmantel style with very high elongation (stretch) potential, giving the capability to absorb the high shock loadings imposed by a falling climber.

Climbing ropes are highly specialised, and are used for specialist purposes in vertical rescue operations.

WARNING NOTE:

Dynamic climbing rope must not be used as a working rescue line.

SMALL DIAMETER KERNMANTEL CORDS

A wide range of static kernmantel cords are manufactured for climbing, caving, and vertical rescue applications, in diameters from 5mm to 9mm. These are specialist ropes, but they can be used for a range of disaster rescue tasks.

The mean breaking loads of these cords will vary between manufacturers, but typical ratings for the most common diameters are:

Diameter	Breaking Force
6mm	700 – 750kg
7mm	1000 – 1200kg
8mm	1200 – 1500kg
9mm	1600 – 1800kg

OTHER SYNTHETIC FIBRE ROPES

Many other synthetic fibres are used in the construction of ropes of both laid and kernmantel pattern. Whilst ropes constructed of these materials do not comply with the New Zealand Standard for static life rescue purposes, they may still have some rescue applications in a major incident.

Materials

Synthetic materials used in **non-rescue** rope manufacture may include:

- Polyester (Terylene)
- Polypropylene
- Polyvinyl Alcohol
- Polyethylene
- Polyaramid (Kevlar).

Rated Strength and Safe Working Load

In most cases it will be difficult to clearly identify a non-rescue synthetic rope acquired for use in a disaster. For this reason, all non-rescue ropes should be treated as if they were ropes of natural fibre, and arbitrarily given rated strengths and safe working loads appropriate to natural fibre ropes of the same diameters.

Care, Maintenance, and Safe Operations

These ropes should be used and cared for in exactly the same manner as for synthetic fibre static life rescue lines.

KNOTS

Rescue personnel should be familiar with the following knots and by constant practice learn how to make and adapt them with speed and proficiency. Knots must always be tied tightly, dressed down, and inspected. As a good rule of thumb, any knot that does not look neat and correct is almost certainly incorrectly tied.

It must be clearly understood that not all knots are suited to all types of rope, due to the risk of slippage and knot failure. This chapter includes:

1. Knots for synthetic fibre rescue ropes
2. Knots for climbing tape
3. Knots for general rescue ropes.

The knots suitable for synthetic fibre rescue ropes can all be used with general purpose ropes, **but only the recommended knots should be used for rescue ropes.**

Stopper Knot

A Stopper Knot (Thumb Knot or Single Figure 8 Knot) is to be tied on all knots (excluding the Figure 8 family of knots and the Alpine Butterfly), to ensure the overall safety and security of the knot.

KNOTS FOR SYNTHETIC FIBRE RESCUE ROPES

Thumb Knot

The Thumb or overhand knot can be used at the end of a rope to stop it passing through a pulley as a security with knots in synthetic rope, or temporarily to prevent the end of a rope from fraying.

- The knot is formed by forming a loop and passing the running end through it.



Figure 8 Knots

The Figure of Eight knots are the preferred knots for forming end loops in synthetic kernmantel ropes, and are highly suited for this purpose in all ropes. They are used to form a non-slip loop that is easy to undo, with a low percentage deduction of the Safe Working Load of the rope.

Figure 8 Knot (Single Figure 8)

This knot can be used in the same manner as the Thumb Knot, to prevent a rope end running through a pulley, or fraying, or to secure a knot tied in a synthetic rope. In general, it is more useful than the Thumb Knot as it is easier to untie.

- To tie the knot, hold the rope away from you, take the standing part in one hand, palm upward, and the running end in the other hand.
- Pass the running end over the top of the standing part making a loop, then carry on with the running end around the standing part, over the top, then down through the loop which you have formed.
- Draw the running end tight and the knot should resemble the figure 8.

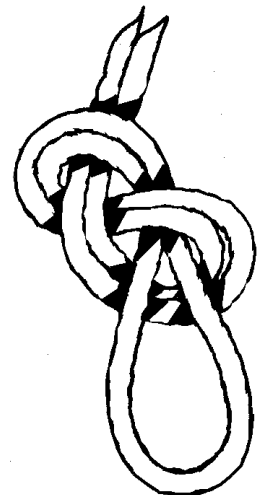

Figure 8 on a Bight (Double Figure 8)

The Figure 8 on a Bight knot is used to form a non-slip loop, which can be placed over a spike, bar, etc

To tie a Figure 8 on a Bight:

- Double sufficient rope to allow the knot to be tied.
- Hold the doubled rope away from you, take the doubled standing part in one hand, palm upwards, and the doubled running end in the other hand.
- Pass the doubled running end over the top of the doubled standing part making a loop, then carry on with the doubled running end around the doubled standing part, over the top, then down through the doubled rope loop which you have formed.
- Draw the doubled running end tight and the knot should resemble the figure 8.



Rethreaded Figure 8

The Rethreaded Figure 8 Knot is used to form a non-slip loop, which must be tied around a bar, through a stretcher, hand-hold, etc.

- Tie a Single Figure 8 Knot as described previously.
- Take the running end and pass it around the object, then follow exactly the path back through the knot that the running end took when forming the original Figure 8.
- Dress and tighten to form the Figure 8 Loop.
- An alternative method where a free loop is required at the rope end, is to double the end of the rope for about 500mm. This doubled rope is tied off in the same manner as the Figure 8 knot and forms a locked bight. This knot is known as the Figure 8 on a Bight.

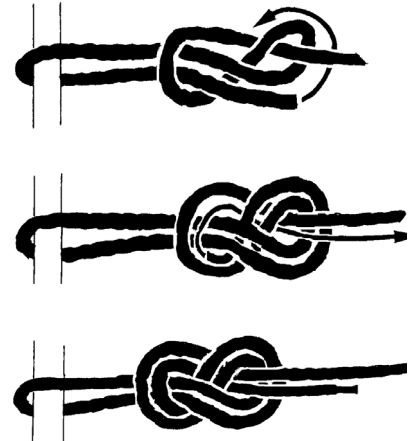
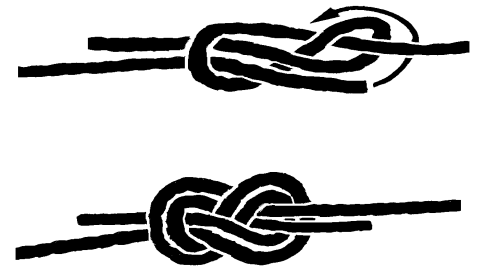

Figure 8 Joining Knot (Figure 8 Bend)

The Figure 8 Joining Knot is the preferred knot for joining synthetic kernmantel ropes

- Tie a single Figure 8 Knot as described previously.
- Take the running end of the second rope and follow exactly the path back through the first knot (as in the Rethreaded Figure 8).
- Dress and tighten both ropes to form the Figure 8 Joining Knot.



Double Figure 8 on a Bight (Anchor 8 or Industrial 8)

This is an exceptionally strong knot to form loops at the end of a rope. It allows you to independently adjust the loops, so that each loop can be used as an anchor point.

- To tie, start with a basic Fig 8 on the Bight, except do not pass the Bight through the final loop.
- Form a new Bight in that end, and place this through the final loop.
- Place the original Bight (single rope loop) over the double and pull it down to the base of the knot.
- To check that it has been tied correctly, there should be 3 loops of rope around the base of the knot and 2 separate bights of rope coming out the end of the knot.

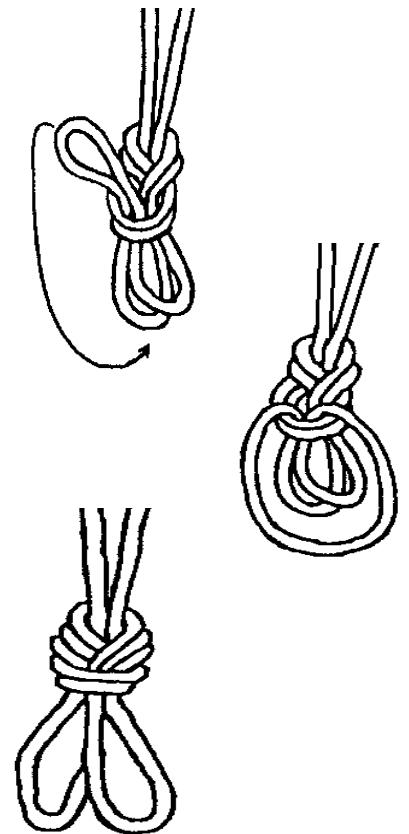

Round Turn and Two Half Hitches

This knot is used for securing the running end of a rope to a spar or ring, and is suited to both synthetic and natural fibre rope.

- It is formed by a round turn on the spar or ring, with two Half Hitches on the standing part of the rope.
- It has the great advantage of allowing a load to be adjusted using the round turn, then finally secured by forming the two Half Hitches on the standing part.
- Extra round turns raise the breaking strain of this knot.
- Finish with a stopper knot.

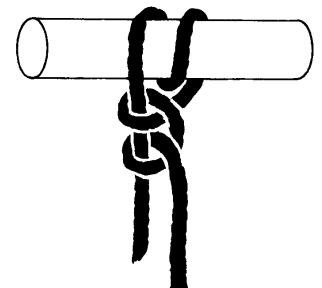

Alpine Butterfly

This is a very strong and useful knot for forming a locked loop at any point of synthetic or natural fibre rope.

There is some confusion in literature as to what constitutes an Alpine Butterfly.

The knots shown are correct in that they form a locked loop which can sustain a three-way loading.

To tie the knot,

- Pass the running end around the palm two times, laying the ropes beside each other, with a gap in between.
- Pass the rope around a third time, laying the rope between the other two.
- Pick up the outside rope, pull out slightly to form a loop, and pass the loop on top of the other two, and then down to pass between the palm and the ropes.
- Pull the loop out from the palm.
- Slide the knot off the hand.
- Pull the ends and loop to dress and secure the knot.

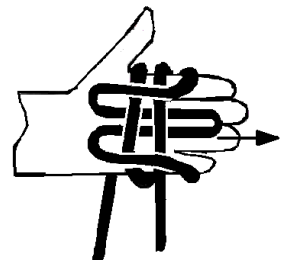
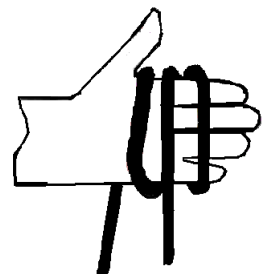
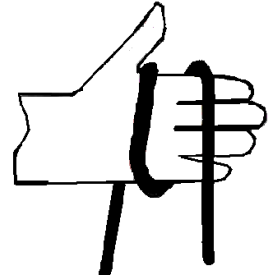

An optional method of tying the Alpine Butterfly is:

- Pick up a Bight of rope.
- Twist the Bight twice in the same direction, holding each of the crossovers.
- Pass the free end of the loop through the opening formed between the two cross-overs.
- Cradle the knot in one hand.
- Pull on each side of the loop to dress and tighten the knot.

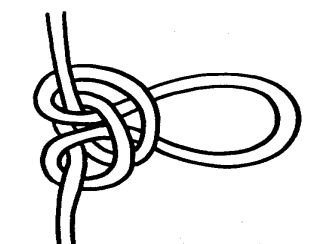
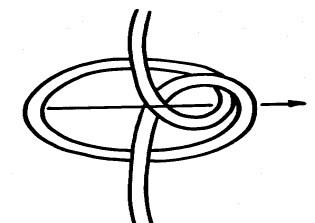
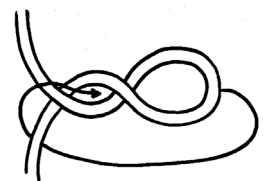

Double Fisherman's Knot

This knot is the most commonly recommended method of joining synthetic fibre ropes, and can be used to join similar ropes of any material of equal or unequal sizes.

- Lay both ropes side by side in opposite directions.
- Make two round turns to the left with the right hand running end, and feed the end under two round turns.
- Make two round turns to the right with the left hand running end and feed this end through the two round turns.
- Dress and pull tight.

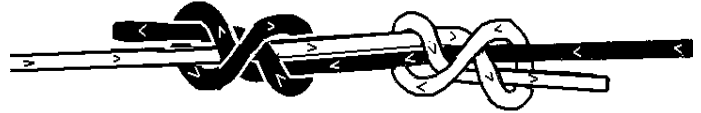

- Whilst the Double Fisherman's Knot can be very difficult to untie once it has been loaded, its great strength is a positive advantage in rescue operations.

Prusik Knot

The Prusik Knot is a method in which a cord sling can be attached to a rope to provide an attachment loop or hand loop.

The position of the loop can be easily adjusted on the main rope.

The cord sling must be at least 3mm smaller in diameter than the main rope for the knot to work, and the Prusik Knot must never be shock loaded.

To tie the Prusik Knot,

- Form the loop by joining the ends of the cord with a Double Fisherman's Knot (as shown previously).
- Place the looped cord over the rope and pass one loop (the first loop) inside the other part of the loop (the second loop).
- Pass the first loop through the second loop two more times (so that there are three passes of the cord on each side).
- Pull the first loop evenly to 'lock' the turns around the rope.
- It is now ready to use, in conjunction with a Karabiner, or similar device.
- To move the knot along the rope, remove the pressure, and slide the knot along by pushing at the turns around the rope.

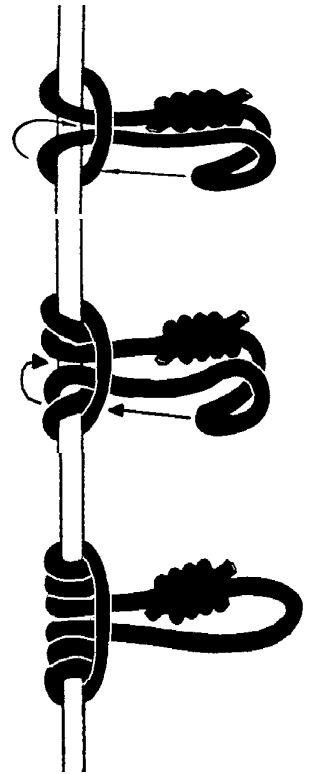

Friction Hitch

This hitch (Italian Hitch, Munter Hitch) is to create friction in a lowering or raising line.

- Pass a bight through a Karabiner or over hard belay point
- Thread one end of the line through the bight.
- Pull tight to dress the hitch, and create the friction point.

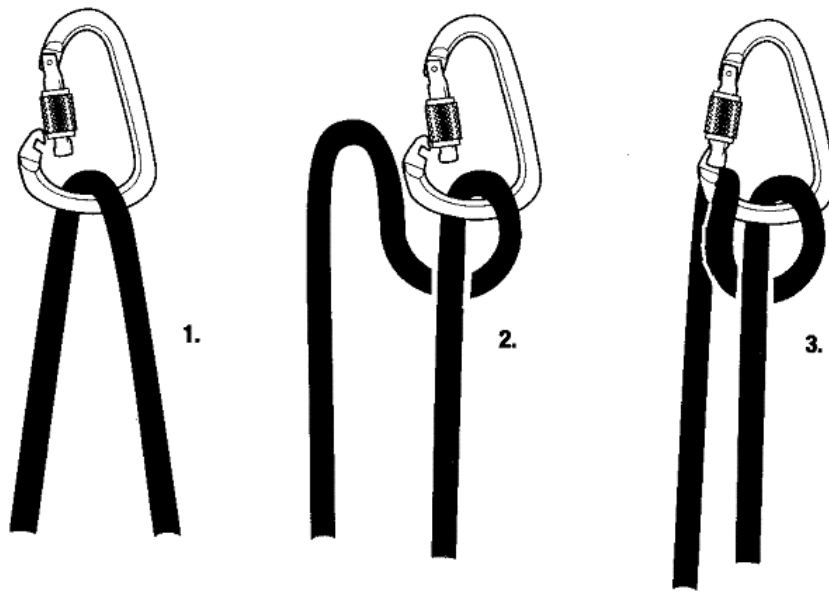

CHAPTER SIX

NATURAL FIBRE ROPES - KNOTS

INTRODUCTION

WARNING NOTE:

Natural fibre ropes are only to be used for rescue as a last resort.

Ropes may be made from a variety of natural materials, the most common of which are Manila, Sisal, Hemp, and Cotton. Manila and Sisal are hard fibres, while Hemp and Cotton are soft fibres. Manila and Sisal were the two materials used in the manufacture of natural fibre rope for rescue operations prior to the adoption of the synthetic fibre rope standard.

The comparison of Manila and Sisal fibres follows:

- Sisal has a harder fibre and therefore makes a stiffer rope.
- New Sisal is white in colour, while Manila is light brown.
- Both fibres are similar in weight.
- Ropes made of both fibres have similar working loads.
- Sisal absorbs moisture more readily than Manila and deteriorates more rapidly.

CONSTRUCTION

Most natural fibre rope is constructed by taking a number of threads or fibres and twisting them into yarns. The yarns are then twisted to make strands and the strands (generally three in number) are laid together to make the finished rope. The number of fibres in the yarns and the number of yarns determine the size of the rope. This type of rope can be left-hand lay or more commonly right-hand lay, which is termed 'Plain' or 'Hawser Laid' rope.

CARE AND MAINTENANCE

- Avoid cutting a rope unless it is essential to do so. If it is necessary, ensure the cut end is whipped (if laid rope) as soon as possible to prevent fraying. As a temporary measure, a Figure 8 Knot can be tied near the end of the rope, or adhesive tape applied.
- Avoid permanent knots in a rope as they considerably reduce its strength by seriously damaging the fibres.
- Avoid, as far as possible, dragging the ropes over rough or sharp surfaces.
- Always use proven knots and fastenings for ropes. Sharp bends or knots can cause some parts of the rope to become overloaded.
- Use correct pulleys, as an attempt to force thick rope through a narrow pulley will cause damage to both elements. Additionally, use cordage blocks and Steel Wire Rope SWR blocks for steel wire rope.
- Avoid shock loading or overloading of ropes or slings.
- Do not step on rope as this will introduce damaging grit and dirt into the fibres.
- Avoid passing a rope over a sharp edge. If this is unavoidable, pad the edge to prevent damage to the rope.
- Ropes that have been worked through mud, sand, or grit should always be cleaned after the work has been completed. This is best managed by washing the rope with clean running water. No form of solvent or cleaning agent should be used.
- Do not dry ropes in front of a fire or other heat source. Spread the rope on a ladder, laid horizontally off the ground to enable the air to circulate freely around the rope.
- Store all ropes under cover, off the floor, and preferably on storage racks. The store should be free of extremes of temperature and from any source of moisture which will particularly affect natural fibre rope.
- Keep all ropes out of contact with any contaminating material such as acids, alkalis, solvents, and the like.
- Try to keep storage area free of rodents, and other vermin.
- If a rope has to be temporarily stored in an exposed location, it should be covered with a tarpaulin or some other form of protection.
- Report damaged or defective items as soon as possible, enter details in the record system and ensure the defect is remedied.

- Regularly inspect the quality of whipping in laid rope. Repair these as required.
- Ensure that natural fibre ropes are not exposed to sunlight for prolonged periods of time, as they will degrade due to the ultra-violet radiation.

INSPECTION OF LAID ROPE

It is essential to have sufficient space to handle the full length of the rope in systematic fashion, and to have good light. The entire length of the rope should be inspected in sections of approximately 300mm at a time, by gently twisting against the lay to expose the inner surfaces of the strands for inspection. Return the strands to their original positions afterwards. The outer layer of the strands must also be inspected.

Check the exterior of the rope for the following:

- Broken fibres – abrasions
- Cuts
- Soft spots – a sure sign of wear
- Decay or burns – heat or chemical
- Any other deformation or irregularity.

Check the interior of the rope for the following:

- Broken fibres
- Powdering – indicating internal damage or overloading
- Dry rot or mildew
- Change in colour
- Any odour of mildew, rot, etc.

RATED STRENGTH AND SAFE WORKING LOAD (SWL)

Natural fibre ropes are manufactured to a tested **Mean Breaking Load (MBL)** which should be clearly displayed on the end plates of the rope drums or an attached rope identification label.

The **Safe Working Loads (SWL)** for these ropes can be calculated by dividing the MBL by a **safety factor of 10** which is considered to be an appropriate factor for rescue purposes.

$$\frac{\text{Mean Breaking Load (kg)}}{10} = \text{SWL}$$

A good rule of thumb technique for determining the SWL of all **new condition** non-rescue ropes in the field is to square the rope diameter (in mm) to provide an appropriate SWL (kg).

EXAMPLE: 16mm Manila rope in new condition:

$$D_{} \text{ (mm)} = \text{SWL (kg)}$$

or $16 \times 16 = 256 \text{ kg}$

Where the rope has been used, or its new condition cannot be guaranteed, it is classed as 'previously used rope', and the SWL must be reduced by half:

$$\frac{D_{} \text{ (mm)}}{2} = \text{SWL (kg)}$$

or $256 \text{ halved} = 128 \text{ kg}$

NOTE: A new 16mm Manila rope can support 256kg safely.

Previously used 16mm Manila rope would only support 128kg safely.

ROPE PACKAGING

Large diameter natural fibre ropes will cause problems due to their bulk and stiffness, but as a general rule, the hanking and sacking procedures for storage of synthetic fibre rescue ropes are entirely appropriate for ropes of natural fibre.

WHIPPING ROPE ENDS

Whilst synthetic fibre ropes can be heat fused to prevent the ends from unlaying or fraying, all laid ropes should be whipped with a small diameter twine or trapped securely to secure the rope ends.

One common whipping technique is shown.

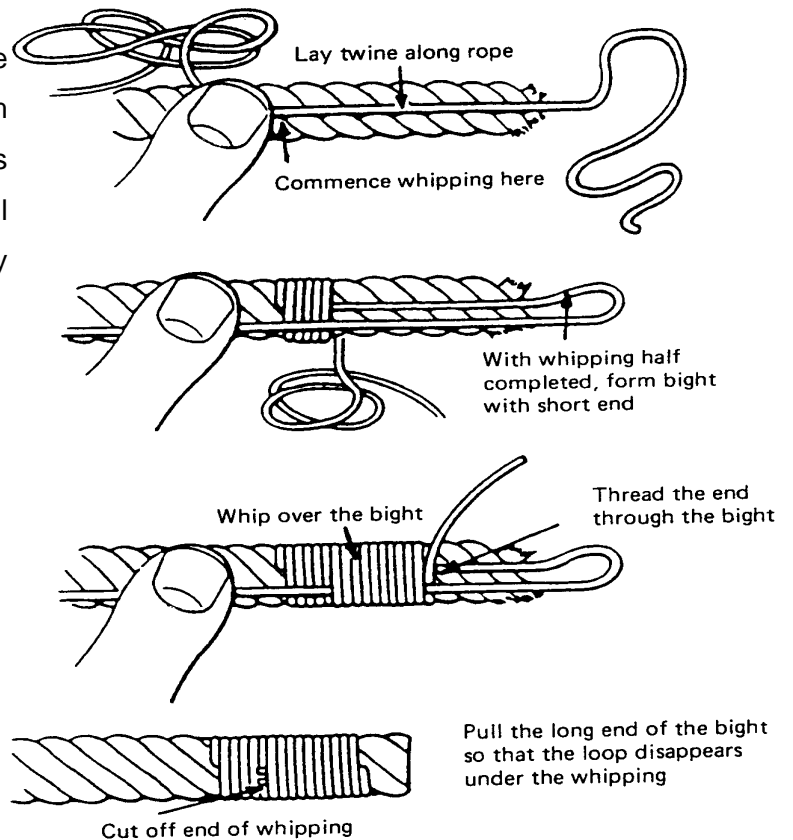

KNOTS

Rescue personnel should be familiar with the following knots and by constant practice learn how to make and adapt them with speed and proficiency. Knots must always be tied tightly, dressed down and inspected. As a good rule of thumb, any knot that does not look neat and correct is almost certainly incorrectly tied.

It must be clearly understood that not all knots are suited to all types of rope due to the risk of slippage and knot failure.

The knots suitable for synthetic fibre rescue ropes can all be used with general purpose/natural fibre ropes, but only the recommended knots should be used for life rescue activities.

Stopper Knot

A Stopper Knot (Thumb Knot or Single Figure 8 Knot) is to be tied on all knots, to ensure the overall safety and security of the knot.

Thumb Knot

The Thumb or overhand knot can be used at the end of a rope to stop it passing through a pulley as a security with knots in synthetic rope, or temporarily to prevent the end of a rope from fraying.

- The knot is formed by forming a loop and passing the running end through it.



Figure 8 Knot (Single Figure 8)

This knot can be used in the same manner as the Thumb Knot, to prevent a rope end running through a pulley, or fraying, or to secure a knot tied in a synthetic rope. In general, it is more useful than the Thumb Knot as it is easier to untie.

To tie the knot:

- Hold the rope away from you, take the standing part in one hand, palm upward, and the running end in the other hand.
- Pass the running end over the top of the standing part making a loop, then carry on with the running end around the standing part, over the top, then down through the loop that you have formed.
- Draw the running end tight and the knot should resemble the figure 8.



General Purpose Knots

Half Hitch

This is formed by passing the running end of a rope around a spar (or around another rope) and under the standing part so that when pulled, one part of the rope binds on the other.

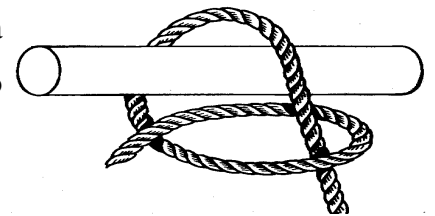

WARNING NOTE:

The following knots **are not suitable for synthetic rope and life rescue.**

They are designed for natural fibre ropes and non-life rescue activities.

- Clove Hitch
- Timber Hitch
- Fisherman's Bend
- Double Sheet Bend
- Bowline

Clove Hitch

This knot is useful for hoisting timbers and rescue tools, and fastening a rope onto another rope, or a spar, at right angles. It is commonly used to start and finish a pole lashing.

To tie at the end of a rope:

- Pass the running end over the spar, bringing it out underneath the standing part.
- Cross over the first Half Hitch and pass the running end around the spar again, bringing the running end under itself to tighten, pulling both the running end and standing part.

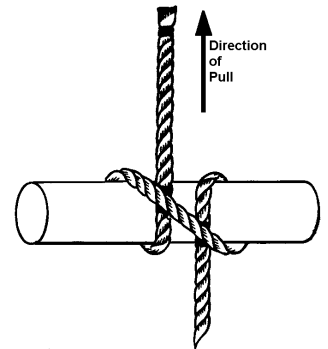

When tied near the end of a rope, it is a good anchoring hitch, which can easily be untied

To tie the Clove Hitch in any other part of a rope:

- Two loops are formed, one in the left hand (clockwise) and one in the right hand (anti-clockwise).
- The right (anti-clockwise) loop is passed in front of the left (clockwise) loop.
- Both loops are then passed over the pole and pulled tight

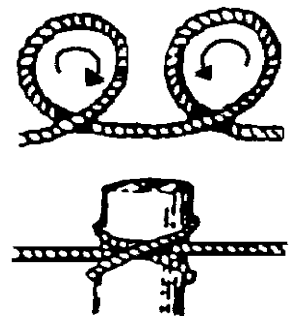

WARNING NOTE:

The clove hitch should not be used at the end of a synthetic fibre rope except when forming a pole lashing.
Knot creep and slippage will be considerable and will pose a safety risk.

Timber Hitch

This is a quickly made hitch used to secure a synthetic or natural fibre rope to a plank or spar.

- It is formed by making a Half Hitch on the standing part of the rope leaving a long end which is twisted for a minimum of 3 turns with the laid rope, and 5 turns with Kernmantel rope, around its own part of the hitch.
- When used for lifting spars, planks or poles, this hitch should be used in conjunction with a Half Hitch at the upper end of the spar.

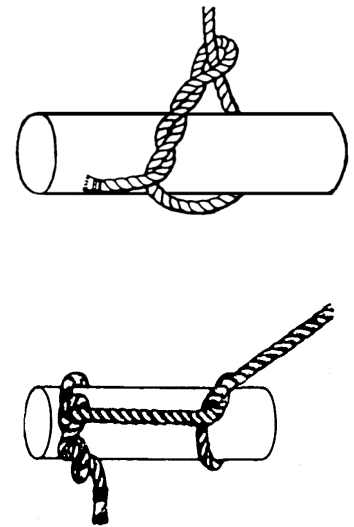

Fisherman's Bend

This bend can be used when anchoring lines, and is a variation of the Round Turn and Two Half Hitches.

- Take a round turn around the anchor point, bringing the running end out under the standing part.
- Feed the running end through the two turns from the top.
- Tie off two or more Half Hitches around the standing part.
- Finish with a stopper knot.

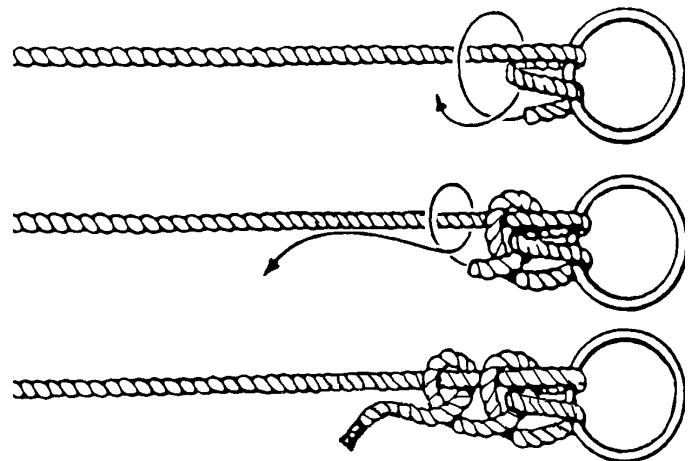

Double Sheet Bend

This bend is used for joining natural fibre laid ropes regardless of their diameter.

- It is made by forming a bight in the thicker of the two ropes and holding this in the left hand.
- Pass the running end of the smaller rope up through the bight and around both thicknesses of the thicker rope and pass under its own standing part.
- Pass the running end around both thicknesses of the thicker rope and pass under its own standing part a second time.
- Ideally the running ends of both ropes are on the same side of the finished knot.

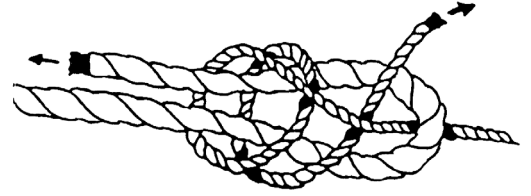

Bowline

The Bowline is a knot that is only safely suited to laid ropes.

A bowline is not safe for use with synthetic fibre ropes of Kernmantel construction, due to the high risk of knot creep.

The Figure 8 Loop, or Figure 8 on the Bight, should be used for safety.

- Hold the rope in the left hand and form a small loop over the top of the standing part.
- Hold the loop in place with the thumb of the left hand.
- Feed the running end through the back of the loop, round the standing part and tuck the end back through the loop.
- Dress and pull tight.
- Adjust to the correct tension.
- Finish with a stopper knot.

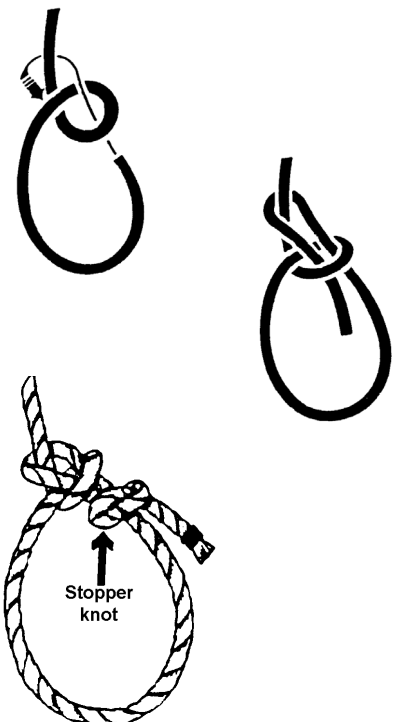

KNOT SAFETY

The following points relating to knot safety should be observed in all activities:

- Knots must be selected which are appropriate to the task and to the rope in use. This is of particular importance with synthetic fibre Kernmantel ropes.
- Any knots tied, at or near, the end of a synthetic fibre rope can be protected with a Thumb Knot tied on the inactive side of the knot to prevent slippage.
- Knots must be tied with a minimum tail of 100mm protruding from the knot.
- All knots must be monitored and checked throughout any operation.
- Knots must not be left permanently in a rope as they will deform the rope fibres and weaken the rope.
- Due to the risk of knot creep and failure when forming knots in synthetic fibre ropes, all tasks for which the Bowline may traditionally have been used, should now be accomplished with one of the Figure 8 family of knots.

KNOT STRENGTH

It should be noted that the safety factor of 10, which is normally applied to ropes in use, takes into account the reduction of strength caused by tying knots.

CHAPTER SEVEN

ANCHORS AND HOLDFASTS

INTRODUCTION

Anchors and holdfasts are used in rescue for the purpose of securing a line, rope, or wire that will be under load. They fall into three main classes:

1. **Natural** – Trees and boulders
2. **Constructed** – Those that have to be set up (eg. by use of pickets and lashings, anchor devices, buried baulks, or timber)
3. **Improvised** – Those found on the site, (eg. Reinforced concrete or metal standards, metal framework of buildings, baulks of timber across door openings, etc).

NATURAL ANCHORS

The most readily identifiable anchor points are trees, large rocks, and spikes of rock. These must be carefully selected, with regard to load and direction of load. These points should not be too close to risk areas, and must be tested by a hauling crew before use.

CONSTRUCTED ANCHORS

Picket Holdfasts

Pickets are suitable as anchors, used as single pickets.

It is recommended they be placed into a holdfast system. These can be arranged as:

- a 1 & 1 or
- a 2 & 1 or
- a 3 & 2 & 1 system,

according to the situation.

The following points should be observed:

- The pickets should be driven into the ground at about 90 degrees to the line of pull, at an approximate angle of 45 degrees from ground level, leaning away from the load, and with two-thirds of their length into the ground.
- The strongest picket should be nearest the load.

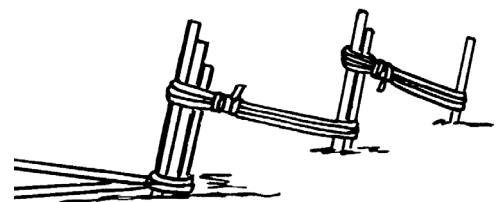
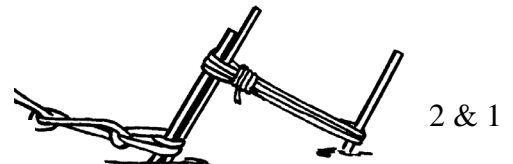
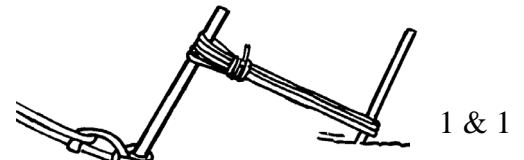

3 & 2 & 1

- The lashings connecting the pickets should be at 90 degrees to the pickets and should go from the head of the one in the front to ground level on the one behind. This determines the distance between the pickets, which should be more than 700mm apart.
- Anchor systems should be monitored at all times.
- As a rough guide to safe working loads a 1.5m x 25mm mild steel picket driven into ground with good holding qualities will safely support a load of approximately 350kg.
- As the number of pickets in the holdfast is increased, the load it will support is increased by approximately 350kg for each picket.

NOTE: When using angle iron pickets, the V of the picket must face the load. Padding must be used.

Placement of Pickets

- Pickets are placed either using heavy hammers or impact drivers.
- They should be positioned and held by two rescuers, each holding one end of a short cord taken around the picket in a Clove Hitch, whilst a third rescuer hammers the picket into the ground.
- Rescuers must wear safety glasses / goggles and leather gloves.
- Pickets are often capped lengths of pipe with internal diameter greater than the pickets.
- Some are fitted with handles and used in place of hammers to drive the picket by sliding impact.

Picket Removal

- Pickets can be removed from most placements with a large stilson or pipe wrench.
- The wrench is fitted to the shaft of the picket and used to wind the picket around and out of the ground as the rescuer exerts an upward pressure on the wrench handle.

NOTE: For angle iron V pickets, reverse hammering, leverage or high lift jacks are suitable for removal.

Picket Lashings

- Each lashing is formed using a 12m rope.
- The lashing should be started by a Clove Hitch about 180mm from the head of the front picket.
- Four turns should be taken around the base of the back picket and the head of the front picket, placing these above the Clove Hitch.
- Turns should be applied around the lashing, finishing off with a Clove Hitch around the lashing, thus using up whatever spare rope is left.
- The lashing must be tightened before commencing the frapping turns.

Buried Holdfasts

With this holdfast, a stout piece of timber, a length of steel girder, a large diameter water pipe, or a vehicle spare wheel is required.

- A trench is dug to accommodate the material used and a small outlet made at right angles to the trench to allow the rope or wire to come to the surface.
- The greater the load applied, the deeper the trench should be.
- It must be appreciated that the buried holdfast is only satisfactory where the angle between ground level and the rope is small.
- This being the case, the trench need not be filled in, but a rescuer should be detailed to check the holdfast when the initial load is applied.
- Where a round section of material such as a log or pipe is used for the buried holdfast, the positioning of the rope is critical.
- The rope should be taken around the holdfast so that the standing part comes to the bottom of the holdfast and the running end comes off the top of the holdfast.

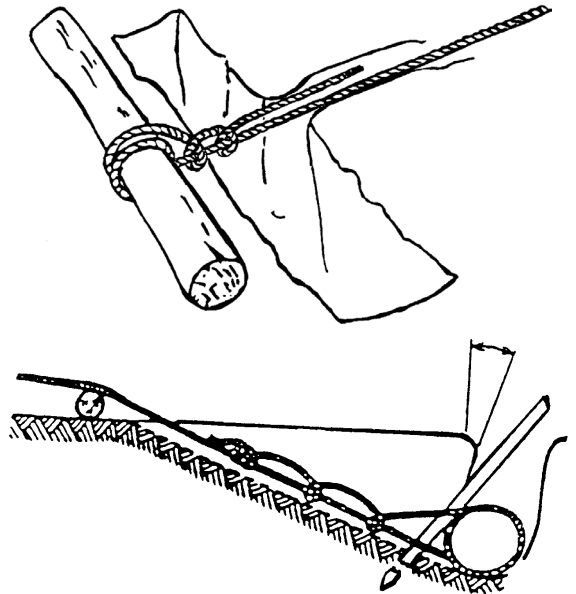

- As the load is applied, this will tend to roll the holdfast down into the trench rather than upwards.

Log And Picket Holdfasts

- This heavy-duty anchor is set up with four pickets properly placed about 400 – 500mm apart, and a second row of four pickets is placed 1m behind the first row.
- A log, beam, or other suitable section of material is laid behind the first row of pickets and each pair of pickets is lashed together.
- This method is of particular use in wet or soft earth and bears evenly against the front row of pickets.

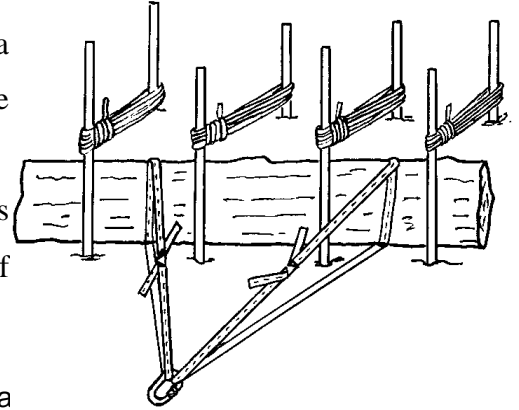

IMPROVISED ANCHORS

When using an improvised holdfast (eg. an electric light pole, a baulk of timber across a doorway, or a heavy vehicle, etc), care should be exercised in assessing whether or not the item selected will in fact carry the load, and that it is correctly placed relative to the anticipated load.

PRECAUTIONS IN OPERATIONS

The following points should be observed in anchoring operations:

- Padding must be placed to protect anchors and slings.
- Pickets should be of sound materials, preferably steel, correctly placed and secured.
- Anchors must be assessed as capable of sustaining the maximum anticipated load in the appropriate load direction.
- Any selected point must be tested in all appropriate load directions.
- All anchor points, slings and attachments must be checked regularly throughout the operation.

SELECTION OF ANCHORS

Given the various types of anchors available, the selection of the most appropriate point or points must always be made on the basis of speed and simplicity.

The first choice for anchorage should always be a large single point capable of sustaining the calculated maximum loading. Where no single point is sufficiently strong to sustain the load, two points can be brought together so that the load is evenly distributed between the two points.

SLING LOADING ANGLES

When the two legs of a sling system form an angle of 120 degrees, each leg is supporting 100% of the load. This is due to the fact that the legs start to pull against one another as the angle increases. Above 120 degrees, the tension begins to increase at an alarming rate. At 150 degrees, the load is 200% of the original load on each leg.

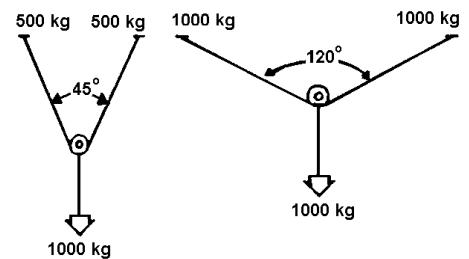

Operationally, 90 degrees is a safe relationship between the two legs of the system, and the smaller the angle, the lower the load on each leg. At an angle close to zero the load on each leg is around 50% of the original load.

The principle for loading angles holds when using a two leg sling to support a load, or when securing a load to two separate anchor points. It is a direct relationship of load and angle of attachment.

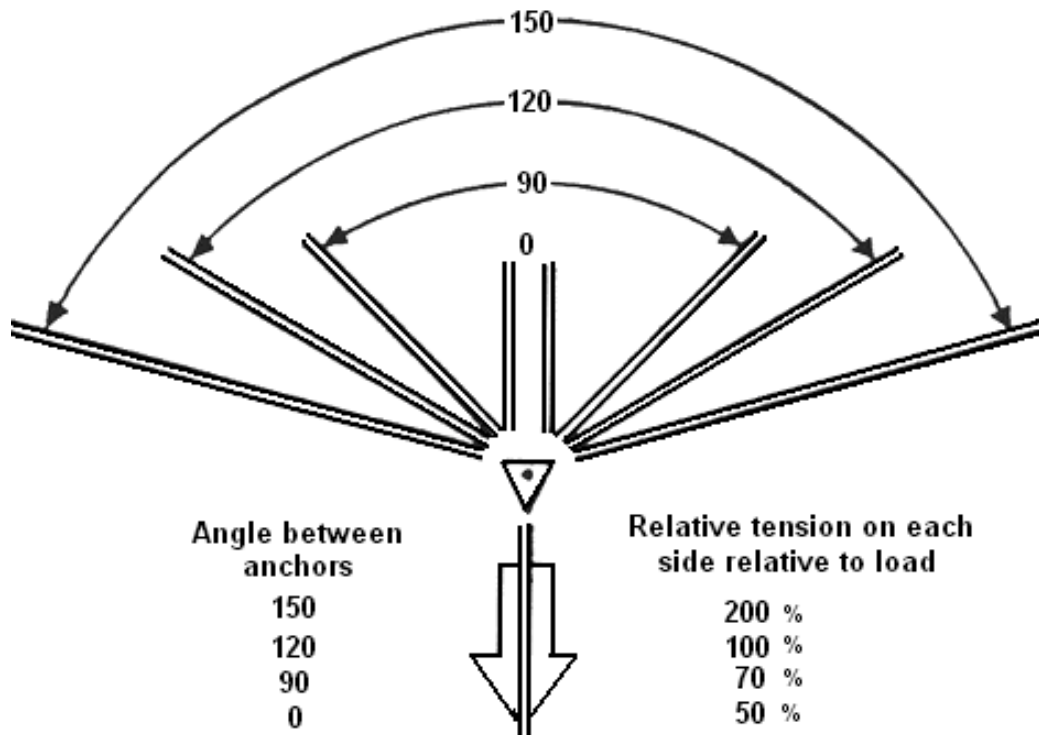

WARNING NOTE:

The angle at which anchor slings meet must never be more than 120 degrees, and should preferably be less than 90 degrees.

ATTACHMENT TO ANCHORS

Ropes may be tied off directly to anchors, providing that the anchor material is padded or will not damage the rope itself. Wherever possible, two independent anchor points should be used as the standard for any task, with the load equally shared between the points.

Rescue anchors are most commonly set up with the load attached by means of climbing tape slings and rescue rated Karabiner. In any single anchor point system, **two tape slings should be taken completely around the anchor, and all four loop ends clipped into the Karabiner.** Where multiple point systems are set up, a single tape sling is acceptable for each point.

Heavy-duty anchor systems are set up using steel wire rope or webbing slings taken around a padded anchor, and connected to the load by means of appropriately rated shackles.

KARABINERS

Known as 'karabs', 'biners', or 'snaplinks' these are the most common item of hardware used in vertical rescue. They are normally a 'D' or modified 'D' shaped metal link, having a spring loaded opening section (the gate) in one of the long sides. The gate allows ropes and slings to be clipped into the Karabiner for attachment purposes.

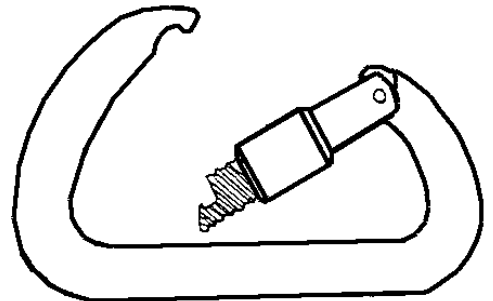

Karabiners are manufactured from either high-tensile steel or alloy, and may have either a plain opening gate, or one fitted with a screw locking device or autolocking gate, which prevents the gate from accidental opening. Consequently, Karabiners are referred to as snaplinks, screwgates, twistlocks, or autolocks.

NOTE: Auto-locking Karabiners are considered to be 'Best Practice' in rescue situations.

Most manufacturers stamp the rated strength of the Karabiner into the metal for easy reference. Rescue Karabiners should be of minimum rated strength of 2500kg.

WARNING NOTE:

Snaplink style Karabiners are **NOT** recommended for rescue.

As these devices are made of specialised steel or alloys, care should be taken not to drop them or knock them on hard surfaces. Small stress points can be introduced into the metal that may then cause deterioration of the device.

Accidental Gate Opening

The main job of a Karabiner is to maintain its link with the other elements of the rescue system. To do this, the Karabiner gate must remain securely closed. If it does not, then the connecting elements will come apart and the system will fail.

There are several ways in which Karabiner gates may come open accidentally. Among the most common situations are where:

- The Karabiner is pressed against an edge or surface, forcing the gate open.
- A rope or section of tape is pulled across the Karabiner gate, forcing it open.

Concerns With Screwgate Karabiners

Any Karabiner that regularly becomes unlocked without apparent reason must be withdrawn from service. Screw gate Karabiners are designed to be locked only to finger tightness. In their concern for safety, and in some anxiety, people will tend to over-tighten a Karabiner gate, and then be unable to unlock it. This most commonly occurs when the gate is tightened while the Karabiner is under load, and unlocking it is readily accomplished by again subjecting it to a similar load.

Karabiner Usage

Karabiners are designed to be loaded along the major axis or spine. As previously stated, the gate is the weakest point of a Karabiner, and any side loading places an unnatural force on the Karabiner, severely reduces its strength, and may cause it to fail.

With some Karabiner designs, vibration can cause the gate locking sleeve to unscrew. Karabiners should always be used in a manner which will ensure that gravity will keep the sleeve in place.

WARNING NOTE:

Maximum strength is only achieved when the Karabiner gate is locked. Karabiners must not be used unless the gate is properly closed and locked.

SHACKLES

There are two principal types of shackle: 'D' and 'Bow'. With 'D' being the most commonly used in the rescue environment. Almost all are made from a plain round steel bar and all are secured by a round section steel pin, and all should comply with New Zealand Standards.

The pin is located through one eye of the shackle and screws directly into the other (threaded) eye to secure the attachment in the shackle.

Shackles must be selected which are large enough to accept the slings or other attachments, and which are appropriately rated for the loading and the task.

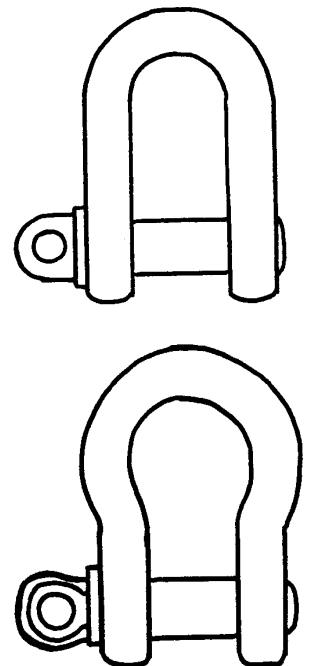

WARNING NOTE:

Only the shackle pin should be used to secure the shackle. The practice of replacing the proper pin with a nut and bolt is highly dangerous and may cause the failure of the shackle.

Safety In Operation

The following safety points should be noted:

- Shackles or pins that are worn more than 10% of the original diameter must be removed from service and destroyed.
- Shackles or pins that have been bent, strained, deformed, or damaged must not be used. They should be removed from service and destroyed.
- Screw shackle pins must be properly tightened and either moused or monitored to ensure that the pins do not unscrew under load.
- Always use shackles of the correct size and shape for the task.

SAFETY SUMMARY

The three-point safety plan recommended for all anchorage operations is as follows:

1. **Select** points which are suitable, strong and safe, and check angles between anchors.
2. **Ensure** all connections are properly made and checked.
3. **Monitor** the anchor system at all times.

CHAPTER EIGHT

LADDERS

INTRODUCTION

Ladders are readily available at most rescue sites and during a disaster may be used for improvised rescue techniques. It must be remembered however, that ladders have been constructed to be used in a specified load bearing position, and should normally be used in accordance with AN/NZS Standards.

CONSTRUCTION

Ladders come in a variety of styles, lengths, and materials. Aluminium, timber, and fibreglass are the three most commonly in use.

EXTENSION LADDERS

Extension ladders are commonly in two sections, with the upper section sliding on and between the stiles of the lower section. Latching devices are fitted to the lower end of the upper section and operate on a movable shaft. Hauling ropes are taken through a sheave fixed near the top of the lower section, brought down, and fastened to hooks or cleats at the bottom of the upper section. One cleat is attached to the latching device thus providing an endless line by means of which the top section can be extended and the latching devices, which are mounted on the upper section, can be engaged or released.

To easily distinguish them in the dark, the stiles of the top section should bear a white line to indicate the limit of safety when extended for use.

Timber ladders are strengthened on the underside of the stiles by galvanised wire or fibreglass which is stretched tautly in the groove along the edge of the strings being secured top and bottom.

Timber ladders are further strengthened by cross ties from stile to stile at intervals.

Ladders should not be painted as paint could hide defects. A small section, at each end, may be painted for identification purposes. Timber ladders may be treated with linseed oil.

Defective ladders must be withdrawn from service and labelled: 'Dangerous – Do not use', and either repaired or destroyed as soon as possible.

WARNING NOTE:

A hazard exists when using ladders in the vicinity of electrical wires as all ladders have the potential to conduct electricity from wires or 'live' roofs or structures. Rescuers must ensure overhead clearance when erecting a ladder.

STEPLADDERS

Stepladders in common use are usually constructed of aluminium or wood, while others are of an aluminium/fibreglass composite construction.

Some stepladders have flat steps on one side, and the other leg of the stepladder may be extended using round rungs to give a three to four metre single ladder.

When using stepladders both as a step, or as a single ladder, care must be taken to ensure that all locks on the ladder are in place

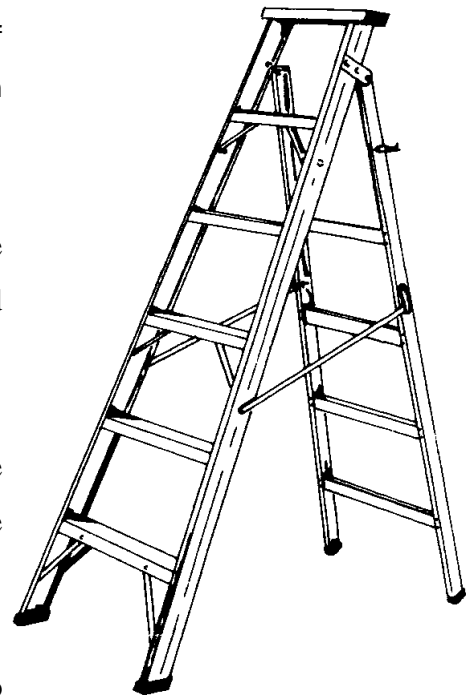

The following checks should be carried out from time to time:

- That there are no cracks or evidence of rungs being loose where they are attached to the strings and all bolts are secure.
- Rungs should be checked for wear, particularly where the pawl crosses the rounds.
- The rubber feet should be checked to see that there is no deterioration.

WARNING NOTE

Aluminium ladders conduct electricity, and are liable to excessive twisting.

TERMINOLOGY

The following terminology is standard for ladder operations:

Head:

The top of a ladder

Stiles/Strings:

The main structural part of a ladder

Latching Device/Pawl:

Metal hooks fitted to extension ladders to lock the ladders in extended form.

Rungs/Rounds:

Cross members used in climbing a ladder.

Hauling Rope:

Pulling line for raising extension ladders.

Foot:

The bottom or ground end of a ladder.

Single Ladder:

A One-piece ladder.

Extension Ladder:

A ladder built in sections, one or more of which can be extended.

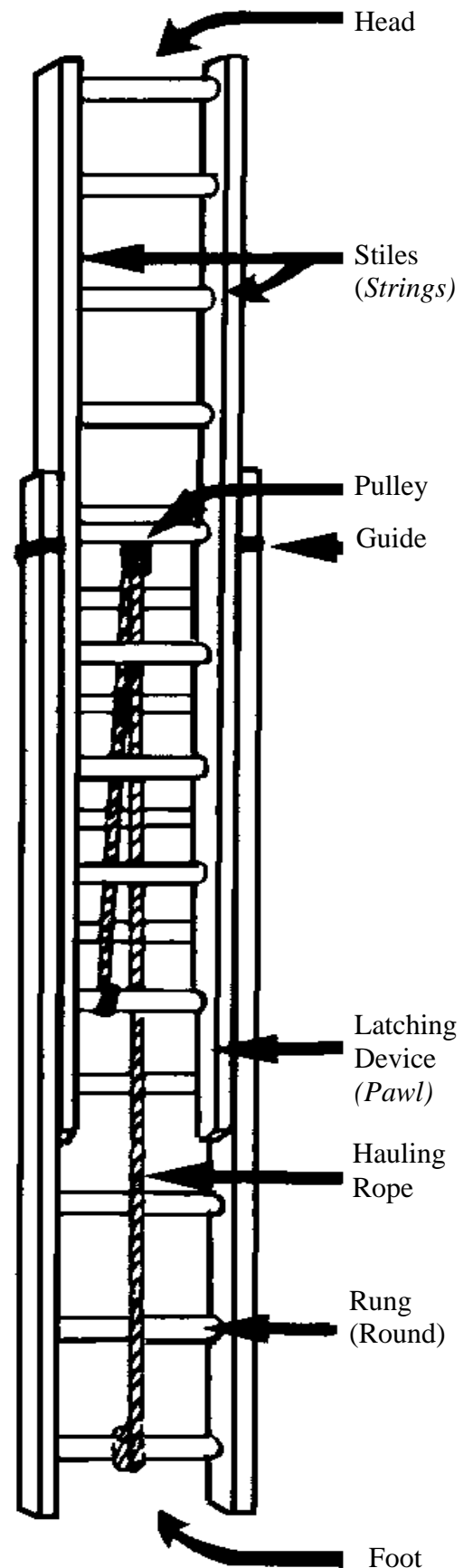

SINGLE RESCUER LADDER RAISE

A single rescuer can quite easily and safely raise a short ladder, by placing the ladder foot against the base of the wall or some other stationery object, and under-running the ladder by walking in and pushing forward and upwards on alternate rungs.



ERECTING AND EXTENDING THE LADDER (TWO RESCUERS)

Place the foot of the ladder against a wall, kerb or some other fixed object

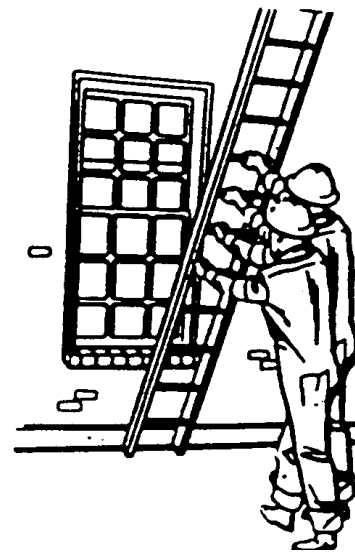

The ladder is under-run in the usual manner by two rescuers, extended to the required height and the foot of the ladder drawn outwards to the correct distance from the wall.

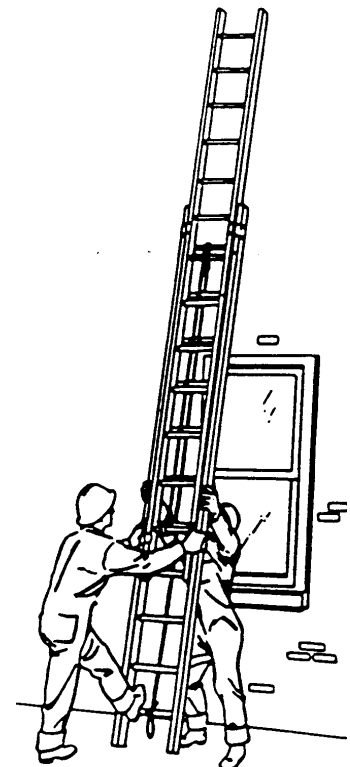

ERECTING AND EXTENDING THE LADDER (THREE RESCUERS)

Ideally three rescuers are required to form a ladder team.

- One person is responsible for the foot of the ladder, both in carrying and positioning where necessary.
- The others support the uppermost stile of the ladder on their shoulders.
- On arrival at the site, one person places the foot of the ladder with the reinforcing wires uppermost (if not uppermost, turn ladder over) as near as possible to its required position and anchors it by 'footing'. The others, working on their respective sides, raise the ladder from the underneath side to the vertical position assisted by the first person.
- The others face the ladder, each 'footing' it, and then the first person, pulling on the hauling ropes, extends the ladder to the required height ensuring that the latching device is properly engaged on the rung.
- The ladder is then laid back by the first person, who walks backward until the top of the ladder comes to rest where required is: against sill, wall etc.

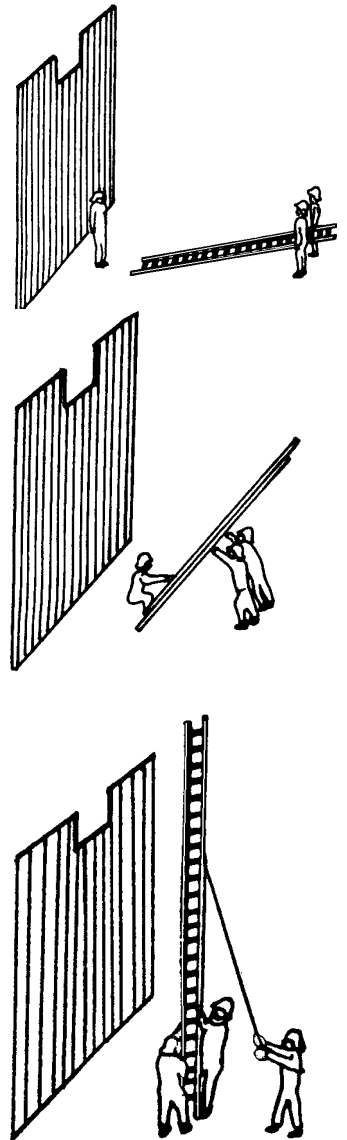

ANGLE OF LADDERS WHEN RAISED

When a ladder is raised, the bottom of the ladder should be placed at a distance from the base of the structure equal to **one quarter of the effective height**.

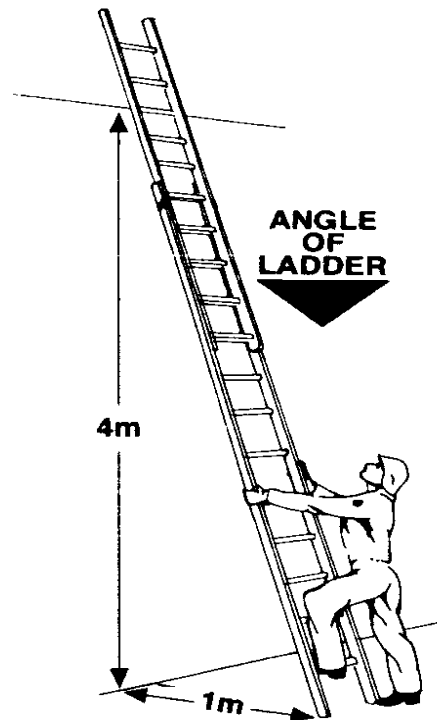

A method to quickly check the angle is to stand in front of the set ladder with your toes touching the ladder. Holding the arm at horizontal to the ground, your fingers should be between the strings, and between or on a round.

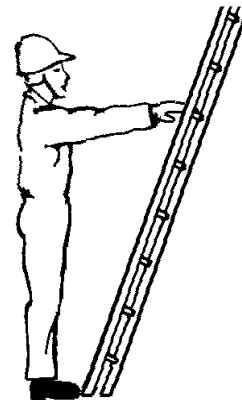

OVERLAPS

Normal two part extension ladders must be extended with sufficient overlap for safety.

- For small ladders (up to 3 metres not extended) an overlap of three (3) rungs is recommended.
- A five (5) rung overlap recommended for large ladders.
- Wherever possible, ladders should be erected so that the head of the ladder projects or overlaps the window, roof, or other landing point by at least one metre.

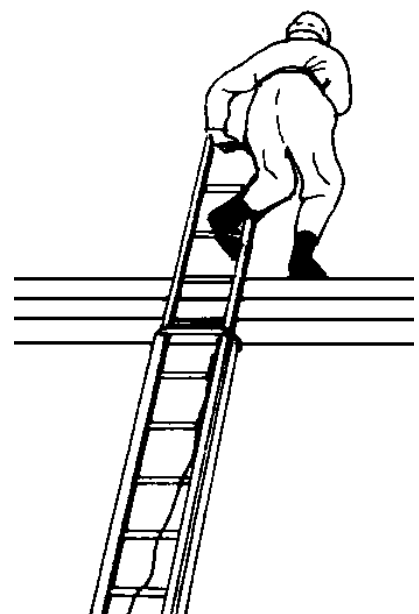

SECURING THE HEAD OF THE LADDER

When it is necessary to secure the head of a ladder, a lashing may be applied to any secure point, for example, a length of timber, long enough to spread across the inside width of a window, may be lashed to the head of the ladder.

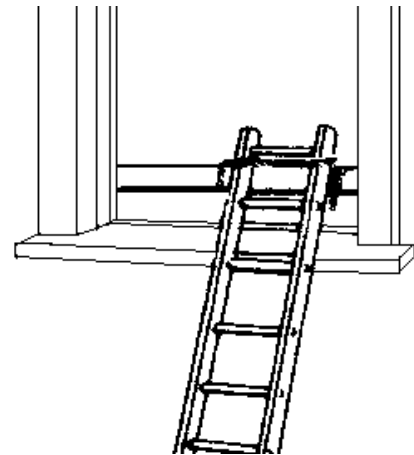

SECURING THE FOOT OF THE LADDER

This may be done as shown by means of fastening to a picket or by tying back to any secure object behind the ladder eg: railings, fence posts etc.

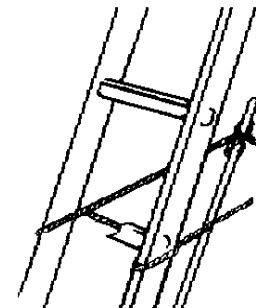

HALVING LADDERS

In some cases it may be necessary to have two short ladders when only one long extension is available.

- This can be achieved by halving the extension ladder, (by removing the sliding extension from the main ladder).
- The ladder should be first placed on the ground, the sliding section uppermost.
- The ropes are uncoupled from the pulley and hooks or cleats, the latching device freed and the upper extension withdrawn. To reassemble, reverse the procedure.
- It should be noted that some extension ladders cannot be halved.

LADDER CLIMBING

WARNING NOTE:

Ladders must be secured or stabilised by 'footing' at all times whilst rescuers are climbing.

The ladder should be climbed steadily, keeping the body erect, the head upright, arms straight but not tense, without any tendency to hug the ladder and hands grasping the rungs at a level between the wrist and shoulders.

- It must be remembered that the legs and not the hands carry the weight of the body when climbing.
- It is generally agreed that it is safer to use the instep rather than the ball of the foot on the rungs.
- When climbing a ladder, the arms and legs should work in unison.
- If possible, maintain 3 points of body contact to the ladder.

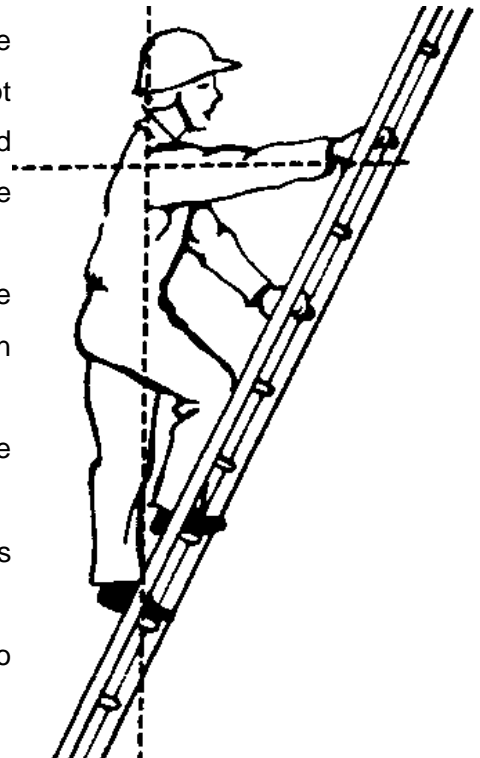

- When working at height on a ladder, the rescuer should be secured to the ladder by means of a lashing, sling, strop or harness, or by using a leg lock.

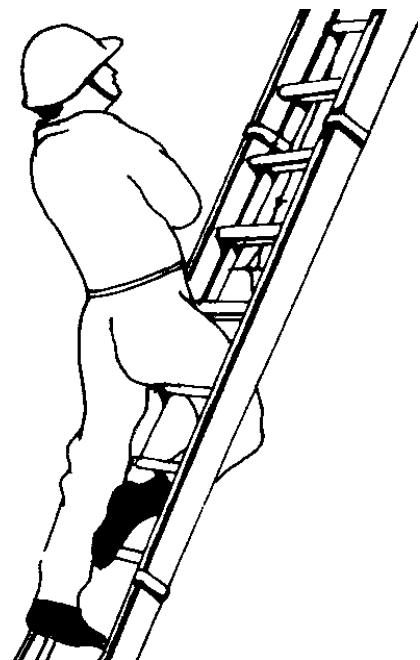

HELPING A CASUALTY DOWN A LADDER

Great care should be taken when helping a person down a ladder, even if that person is conscious and uninjured. Rescuers should keep in mind that many people are unaccustomed to height and may 'freeze-up' or lose their hold.

- The rescuer should take a position, one rung below the casualty, with arms encircling the casualty's body and grasping the rungs.
- The rescuer should keep in step with the casualty, letting them set the pace. The rescuer's knees should be close together, to ensure support in case the casualty loses hold or becomes unconscious.
- The rescuer should also talk to the casualty to keep up morale and overcome fear.
- If the casualty becomes unconscious, they should be permitted to slip down until the crutch rests on the rescuer's knee.
- By repeating this procedure for each step down the ladder, the rescuer can lower the victim to the ground.



Note: The diagrams show two methods. The Rescuer will need to select the appropriate method for the situation.

WARNING NOTE:

This technique could exceed the safe working load of the ladder or de-stabilise the ladder.

MAINTENANCE AND TESTING

Extension ladders must be regularly and carefully checked for damage or defects, in accordance with the relevant Standards. Particular attention must be paid to those ladders that are stored on vehicle roof racks and thereby exposed to the weather regularly.

The ladder should be visually inspected for cracks in the timber, the security of the rungs and reinforcing wires, and for general appearance.

Pulleys, latching devices and extension guides should be checked for lubrication and security, and the latching device pivot points and pulleys lubricated as necessary. Hauling ropes should be checked and replaced as necessary.

Ladders should never be painted as the paint can cover quite serious cracks and defects. Better that timber ladders be left in a natural condition, and regularly oiled with linseed oil, which will keep the ladder flexible, and prevent water damage or rot.

CHAPTER NINE

CASUALTY HANDLING TECHNIQUES

INTRODUCTION

Rescues will be conducted under almost every conceivable adverse condition. The method used for casualty removal will depend on the location of the casualty and the type of injury sustained. In some rescue operations, casualties will have to be lowered from the upper floors of buildings; in others, hoisted from below through holes in floors, or removed by a combination of those techniques. Where casualties are handled by rescue personnel, care must be taken to ensure that further aggravation of injuries does not occur.

All rescuers must be aware that the safety of the casualty is paramount even when immediate evacuation from a hazardous environment is necessary.

A careful assessment must be made of the casualties' injuries, condition, and possible entrapment, and a final check must be made to ensure that the casualty is actually ready to move and is not caught or entangled in some unseen object.

WARNING NOTE:

The importance of first aid training cannot be over-stated.

All rescue personnel must hold a current first aid qualification.

After removal, many casualties will have to be carried over piles of debris and uneven ground before being handed over to the ambulance service or first aid station. Whilst speed of removal is important, it must be consistent with safety and proper handling to prevent further injury.

The method used will depend on the immediate situation, the condition of casualties, types of injuries, and available equipment. Rescue leaders should conduct frequent exercises in the removal of casualties, using live people as casualties to give team members understanding and confidence in the various methods, enabling them to make decisions promptly in times of emergency.

As important as learning methods; rescuers should experience the physical effort required in transporting casualties, either by stretchers or by some improvised method. The transportation of casualties over long distances is a very tiring task and requires fit personnel.

TRIAGE

Where multiple casualties need attention, the rescuer will be required to select casualties for treatment and rescue by order of priority. This selection or sorting of casualties is known as **Triage**.

Rescuers may be called upon to perform the triage role at a rescue site as a specific task, or this may be a part of the overall reconnaissance element of a rescue.

While moving fairly quickly from casualty to casualty, the rescuer performing triage must:

- Quickly assess the condition of casualties and label them.
- Place any unconscious person in a lateral recovery position – care for airway, breathing, and circulation.
- Temporarily control any serious bleeding – by the use of bystanders or other rescuers as necessary.
- Choose the casualties with the greatest chance of survival.

It must be noted that it will sometimes be necessary to treat and rescue casualties of relatively low priority in order to access and clear the way for treatment of high priority casualties. Additionally, the principle of '**remove the casualty from the risk or remove the risk from the casualty**' should be adopted where a site hazard presents a risk to casualties being treated prior to rescue.

CASUALTY SORTING

Priorities are displayed using a colour code system:

- **Red**
Those victims who need immediate advanced medical treatment (within 1 hour) to survive. These victims would have first priority for transport to a medical facility, if available.
- **Yellow**
These victims have serious injuries, but are not life threatening. They will survive without advanced medical treatment and their situation can be maintained through proper basic emergency care.
- **Green**
Minor injuries that can be dealt with by first aid, or can wait for some time without treatment.
- **Black**
Deceased, or who are unlikely to survive given the situation.

WARNING NOTE

These colour codes may constantly change, as the assessment of the casualties and their injuries is an ongoing process.

The victim's colour code may change as the situation changes (e.g. the availability of transport, medical supplies, etc).

In a major incident, be prepared to wait some time without either advanced care on-site, or transport to an appropriate facility.

CASUALTY TAGS

Any tagging system may be used for casualties during a disaster, providing the method undertaken is easily understood by all of those concerned with its use.

The type of casualty tag to be used during a disaster should, where possible, be predetermined and arrangements made to hold adequate stocks of tags for use.

STRETCHERS

The Four categories of stretcher in most common use are:

- Folding or Pole stretcher
- Basket stretcher—incorrectly referred to as the Stokes Litter, or Ferno-Washington.
- Wrap-around stretchers
- Board Rescue stretchers.

FOLDING OR POLE STRETCHERS

WARNING NOTE

These stretchers are not suitable for lowers,
and are only appropriate for casualty movement on the flat.

The folding stretcher must be set up, as follows
before a casualty can be transferred to it:

- Unfasten the straps that hold the stretcher closed.
- Spread open the stretcher and lock the spreaders in place by pushing on each bar **with your foot**, until it locks into place.
- **Do not use your hands** as they can be pinched by the hinges.
- Where it is possible that the centre hinge of the spreader bar may be snagged, causing the hinge to unlock and collapse the stretcher, a securing rope should be used.
- A short length of rope can be tied from one stretcher handle to the centre hinge and then to the other stretcher handle in 'V' pattern.
- The Clove Hitch or Round Turn and Two Half Hitches is ideal for all three knots of this rig.

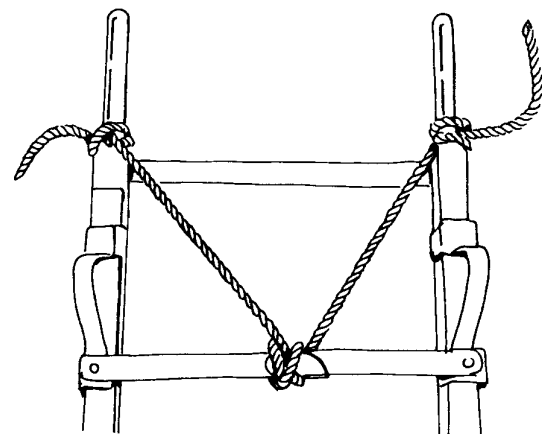
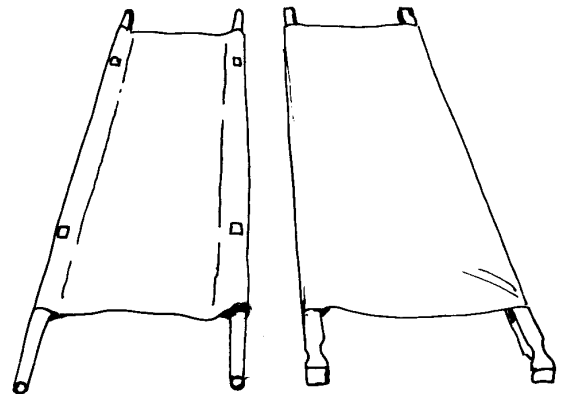

BLANKETING THE STRETCHER

Before a casualty is placed on a stretcher, it should be covered with a blanket so that no contact is made with the canvas bed portion. This adds to comfort, keeps the casualty warm, and to a large degree helps immobilise any fractures that may have been sustained. Depending on the weather, and the supply of available blankets, one or two blankets can be used. In very warm weather a cotton bed sheet or sheets may be used instead of blankets.

Single Blanket Method

- Lay one open blanket diagonally down the stretcher with the corner of the blanket in the centre of the top of the stretcher, and about 150mm overlapping.
- Place the casualty on the blanket with the head level with the top.
- Fold over and tuck in the lower half of the blanket.
- Do likewise with the top half.

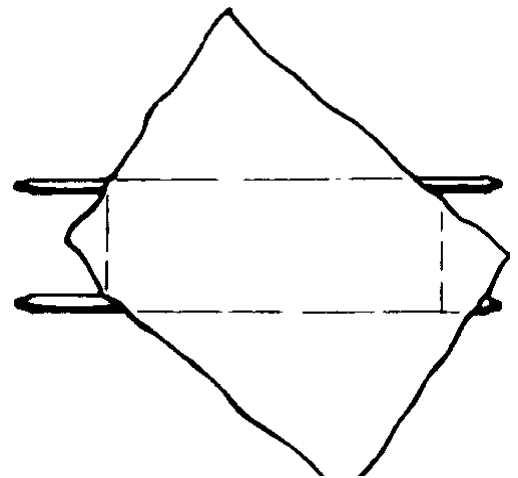

Blanketing – Lateral/Recovery Position

In addition to warmth, comfort, and immobilisation, the blanket is used for padding to keep the patient in the required lateral/recovery position.

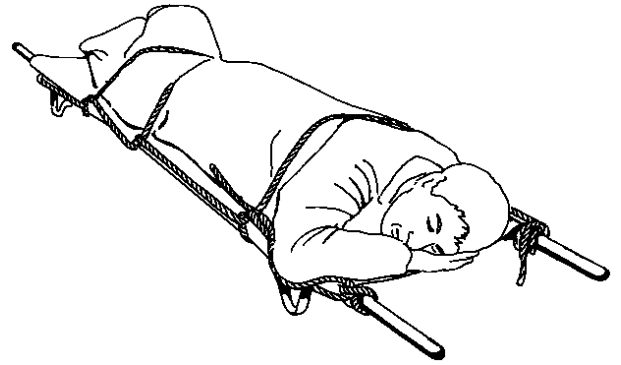

The following is the recommended method:

- Roll a blanket end to end and position it on the stretcher so that the roll is used to pad the patient's back.
- A second blanket is placed on the stretcher in a similar manner with the rolled portion on the opposite side, and the blanket folded over the patient and tucked under the first roll.

LOADING A STRETCHER

- Loading a stretcher is an important part of casualty handling.
- Correct methods are essential for the well being of the casualty to prevent aggravation of injuries.
- Final checks must be made by hand to ensure that a casualty is actually free to lift before a lift is executed.

WARNING NOTE:

The casualty's head and neck must be supported at all times.

The Four Rescuer Method

When using four rescuers to load a stretcher and where spinal injuries are not suspected, the following method can be used:

- The stretcher is made ready and placed near the casualty's head or feet.
- The leader details three others to kneel down on one knee on one side of the casualty (casualty lying flat on back). They all have the knee up closest to the casualty's head.
- The leader kneels near the casualty's hip on the opposite side to the three others and eases the casualty on to one side.
- The other three place their hands and arms underneath the casualty and the leader lowers the casualty onto their arms.
- The leader gives the order: **Prepare To Lift** and, if no one dissents, follows it with: **Lift**, whereupon all four lift.
- If necessary, the casualty can be briefly supported on the rescuers knees. The leader then places the stretcher under the casualty.
- Final orders are: **Prepare To Lower**, then: **Lower**.
- The three rescuers, assisted by the leader, lower the casualty on to the stretcher.

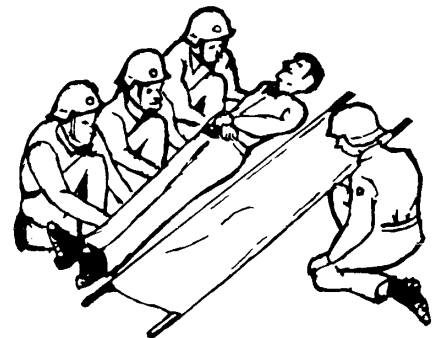

Blanket Lift (Four Or Six Rescuers)

This is an effective method for loading or moving a casualty in a confined space.

- Make a stretcher ready using one blanket.
- Roll a blanket lengthways for half of its width and lay the rolled section along the side of the casualty (casualty flat on back).
- The leader then directs two (or three) rescuers to kneel down on each side of the casualty.
- The rescuers on one side ease the casualty over on one side and the rolled section of the blanket is pushed well underneath the casualty.
- With the rolled up section of the blanket now under the centre of the casualty, the casualty is eased over in the opposite direction and the blanket is unrolled. The casualty should now be lying flat on their back.

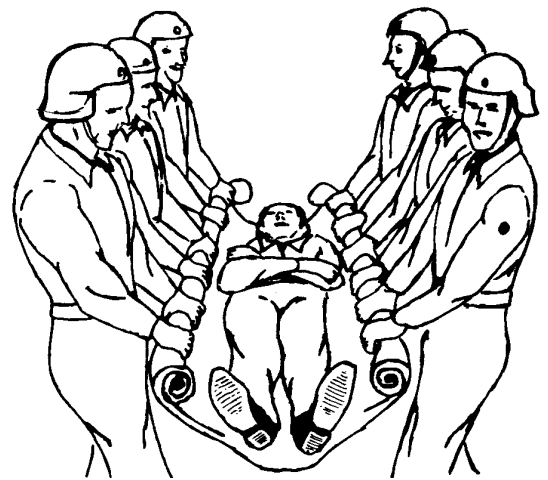
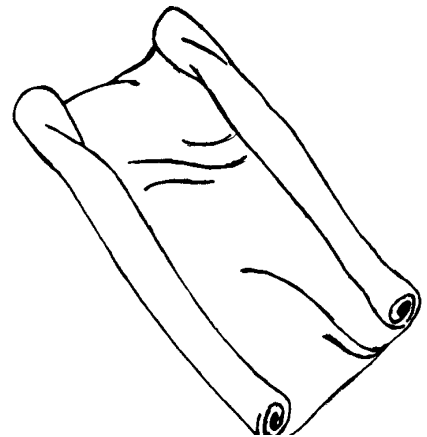

- The sides of the blanket are rolled up close to the casualty's body to provide handgrips for the bearers.
- On the order from the leader, the casualty is lifted waist high, and carried to the stretcher.
- On the order from the leader, the casualty is lowered onto the stretcher.
- The blanketing is then completed with one blanket, leaving the lifting blanket in position.
- This 'blanket carry' can also be used as an improvised stretcher for carries over moderate distances.

WARNING NOTE:

Suspected spinal injured casualties can be safely transported by this method with correct immobilisation of the spine and with particular attention paid to the head and neck.

Clothing Lift (Three Rescuers)

This is an emergency method which can be used when the casualty's injuries are not too severe, and time is critical.

- Blanket a stretcher and place it close to the side of the casualty.
- Tie the casualty's hands together with a triangular bandage or similar material if unconscious.

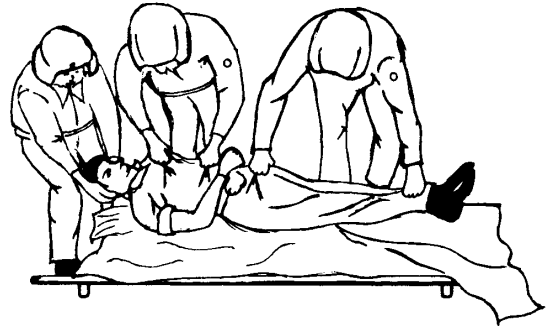

- Roll the casualty's clothes together along the centre of the body.
- Three rescuers take up the position on the opposite side of the casualty to the stretcher and position their hands.
- The normal commands are given (**Prepare To Lift**, etc) and the casualty is gently placed on the stretcher.

Webbing Bands (Five Rescuers)

In some cases it may be necessary to transport a casualty some distance to a place where a stretcher can be loaded. Webbing bands can greatly assist this operation. While there are many configurations that can be used, one suggestion is:

- The bands are placed in position by pushing the long steel handle under the natural body hollows and see-sawing the bands into the requires position, i.e. under the buttocks and shoulders.
- After bands are correctly positioned, the handles of each band are centred above the middle of the casualty and the five rescuers take up position.

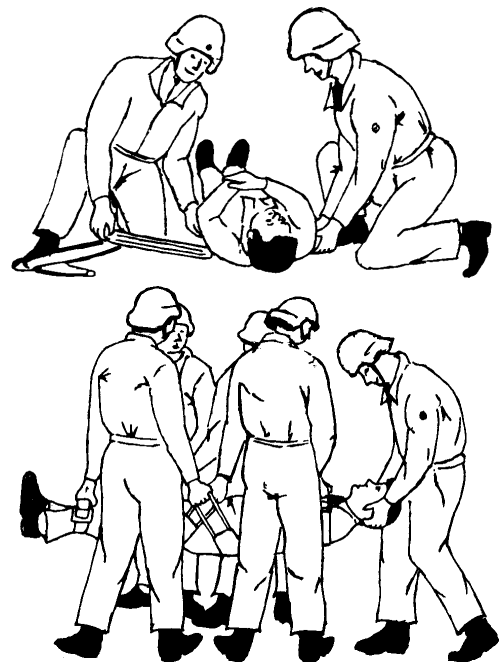

Specialist Lifting/Loading Devices

Specialist lifting/loading/extraction devices such as timber or synthetic spinal boards, scoop stretchers, and spinal immobilisation devices or harnesses are readily available from rescue equipment suppliers.

These devices should always be used in compliance with manufacturers' specifications and recommendations, and following appropriate specialist training.

LASHING THE CASUALTY TO THE STRETCHER

In many cases, casualties will have to be firmly secured to the stretcher to enable it to be handled in different places. No hard or fast rule can be laid down as to when the casualty should or should not be lashed in, however, the nature of the rescue should in itself provide the answer. **If in doubt, lash the casualty in.**

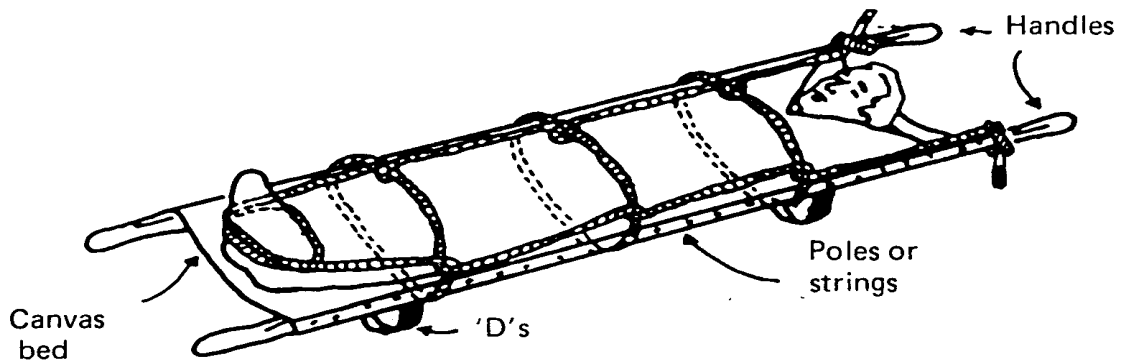

The ideal size and length for stretcher lashing is 12 metres of 11mm or 12mm rope.

- Commence the stretcher lashing by forming a Figure 8 Loop around one of the top stretcher handles.
- From this point take three Half Hitches around both the casualty and the stretcher, first in the region of the chest, the second in the vicinity of the wrist and the third hitch just above the knees.
- A round turn is then taken around the feet and three Half Hitches applied to those already formed on the opposite side of the casualty's body.
- The lashing is finished with a Round Turn and Two Half Hitches on the remaining stretcher handle.
- The position of the three securing Half Hitches can be varied according to the location of the injuries that the casualty has sustained. In the case of a female casualty, the top securing hitch should be placed just above the breast line.
- Bricks or timber placed under the stretcher D's before lashing commences, will enable the rope to be passed under the stretcher more easily.

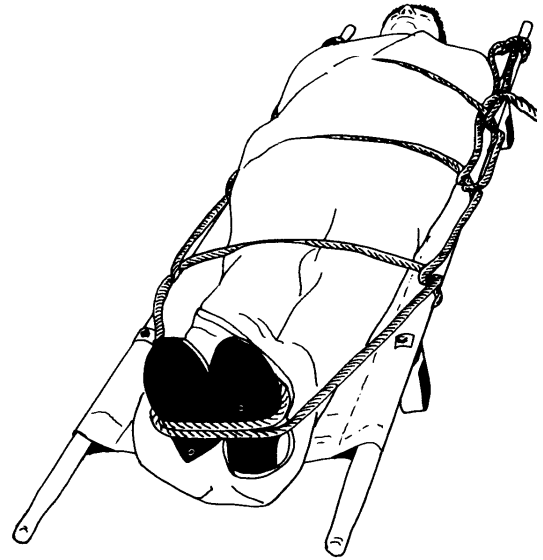

Lashing - Lateral/Recovery Position

The lashing of the stretcher differs from the normal method in that the rope does not pass around the feet.

- The middle lashing is positioned under the casualty's buttocks to prevent movement downwards.
- Instead of passing a loop around the casualty's feet, the line is Half Hitched around each handle at the foot of the stretcher.

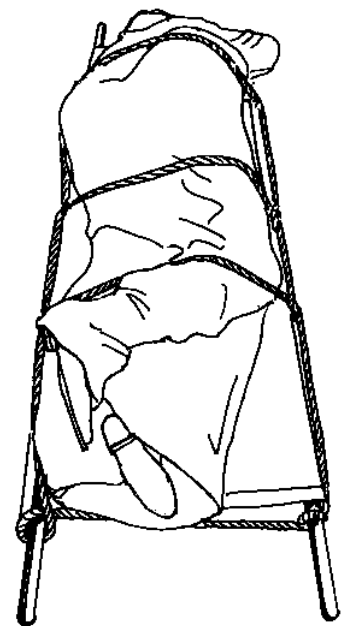

BOARD RESCUE STRETCHERS

WARNING NOTE:

A rope lashing system should be used at all times other than when the stretcher is moved over smooth and flat ground.

WARNING NOTE

Care must be taken if this stretcher is used for lowering as the high centre of gravity can cause the stretcher to invert, particularly when using the two-point suspension method.

Many organisations have Board Rescue Stretchers available. This type of stretcher has a number of advantages for the rescue environment:

- Providing protection for the patient from underneath.
- A number of handholds.
- Relatively inexpensive.
- This stretcher is suitable for patient transport and some rescue techniques.
- A footplate is usually used to prevent the patient sliding downwards if the stretcher is tilted towards the vertical position.

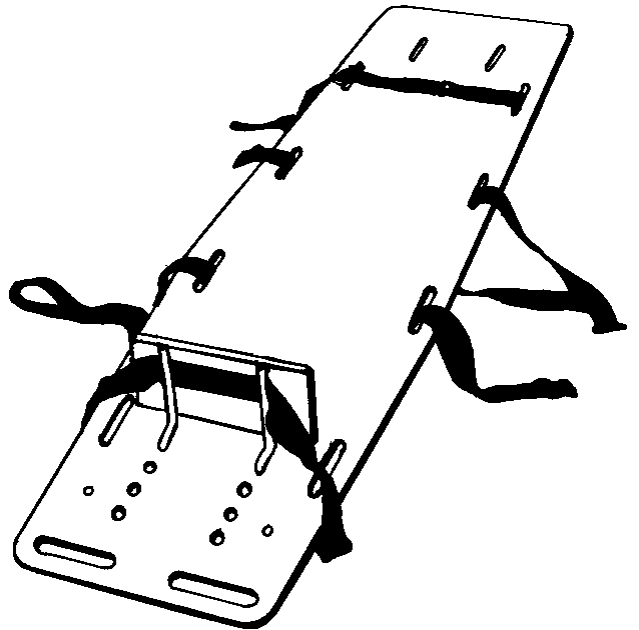

Board Rescue Stretcher Lashing

The patient should be lashed to the Board Rescue Stretcher whenever it is going to be lowered. This may also be necessary if carrying the patient in rough or difficult terrain eg: rubble, confined spaces, and the stretcher does not come with webbing or nylon straps.

A 12m rescue line is used to lash the Board Rescue Stretcher.

The process is as follows:

- Begin with a Rethreaded Figure 8 through the top most handhold or hole (depending on the design of the stretcher this may be on the top or bottom edge, or along the sides).
- Pass the line down the side of the board.
- Take a complete turn under the board and back across the casualty's chest.

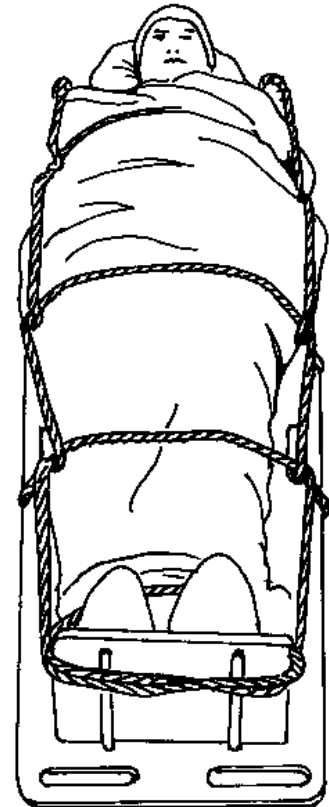

NOTE: Some Board Rescue Stretchers have runners underneath and some runners have slots in them for the rope to pass through. This has the advantage of minimising ropes being scraped on the ground or building edges.

- Form a hitch by passing the line between the board and where the line passes under the board. Tighten gently.
- This is repeated across the casualty's wrists and again just above the casualty's knees.
- A complete round turn is taken around the feet.
- The rope is then taken up the other side of the board forming hitches on each turn of the lashing.
- Complete with a round turn and 2 Half Hitches on the handhold opposite where the lashing was started.

Attaching Lowering Lines To The Board Rescue Stretcher

Lowering lines are attached to the Board Rescue Stretcher for the two or four point suspension lower by:

- Forming a Half Hitch around the handhold closest to the appropriate corner.
- A rethreaded Figure 8 is formed through the next adjacent handhold on the side of the Board Rescue Stretcher.

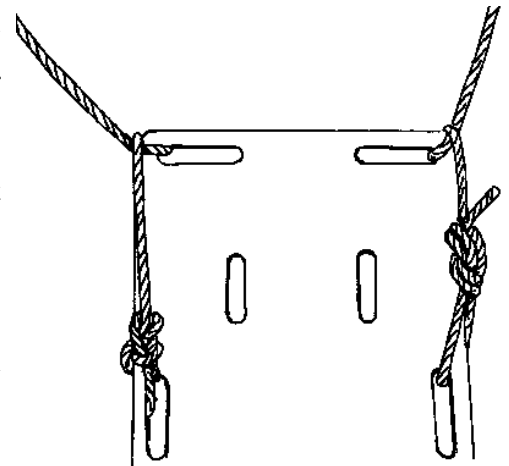

BASKET STRETCHERS

There are two types of basket stretcher currently in use. The older type has a strong tubular aluminium frame covered with 'chicken wire', whereas the newer has a formed plastic, fibreglass, or aluminium basket attached to a tubular aluminium frame.

The newer designs have an advantage in that they are less likely to be snagged or penetrated than the wire model.

Other than the very old wire designs, these stretchers can accommodate a 'scoop' style stretcher, or spinal board, thus making the transfer of a spinal casualty easier.

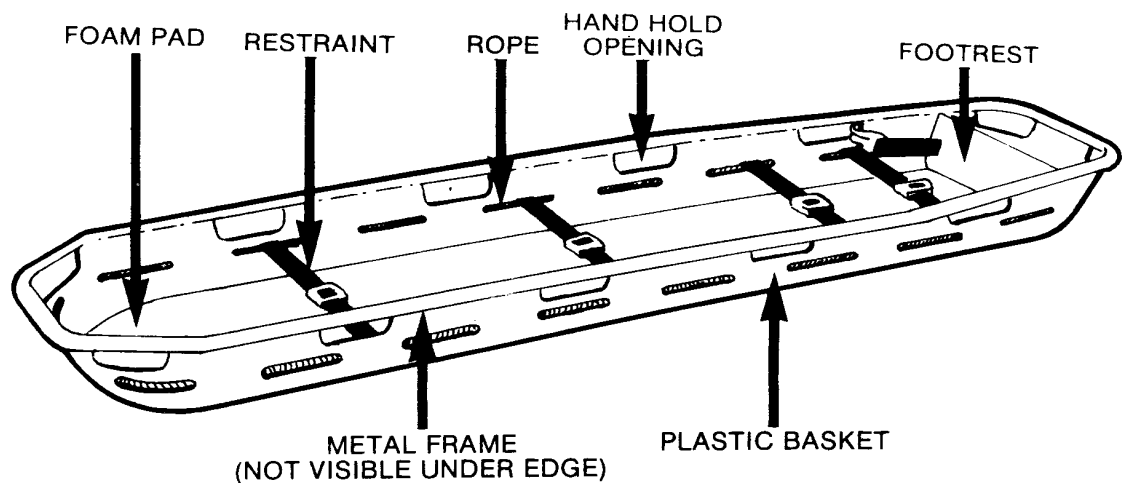

Blanketing A Basket Stretcher

Basket stretchers should be blanketed, particularly in cold weather to ensure the maintenance of body heat, particularly during lengthy rescue or transfer operations.

- Lay an unfolded blanket over the stretcher, with the upper edge of the blanket just beyond the head end of the basket. Use two blankets if necessary.
- Place the casualty in the basket.
- If spinal injuries are not involved, padding can be placed under the head for comfort.
- Fold up the end of the blanket over the feet and tuck between the ankles to prevent chafing.
- Fold over, first one side, then the other, and tuck the blanket in.
- An alternative is to transfer the casualty inside a sleeping bag in the stretcher (where attention to injuries does not preclude this method), or to lay folded blankets under the casualty for insulation.

Securing A Basket Stretcher With Securing Straps

Some basket stretchers are supplied with securing straps with seatbelt buckles or 'Fastex' clips.

- The preparation of an adult casualty for horizontal rescue involves little more than tightening the straps.
- When that patient is small there will be gaps between the patient and the sides of the stretcher. It is not improbable that a casualty could slide out from under the straps if the stretcher was tilted. Gaps between the casualty and the stretcher sides may be filled with blankets, clothing or pillows etc. before the straps are snapped in place.
- Remember that the purpose of strapping or lashing is to combine the patient and the stretcher in a solid manageable unit capable of being carried over hazardous terrain.

Securing A Basket Stretcher By Lashing

- The casualty can be lashed securely to a basket stretcher with a 12m length of 11mm rope, or tape, with the lashing pattern dictated by the casualty's injuries and size, and by the attitude through which the stretcher will move. .
- The two diagrams show optional lashing methods.
- Tape can be used instead of Rope for this lashing.
- If the Basket stretcher has no foot plate, the casualties feet should be secured to prevent them from sliding down the stretcher.
- If the casualty is to be shifted in a vertical position the head of the patient must be secured. Pack soft material on either side of the casualty's head and tie a length of bandage to one lower rail, lay it over the casualties head (not covering the eyes) and tie the other end to the opposite lower rail.
- It is important to continually reassure any casualty who is secured to a stretcher in such a confining manner.

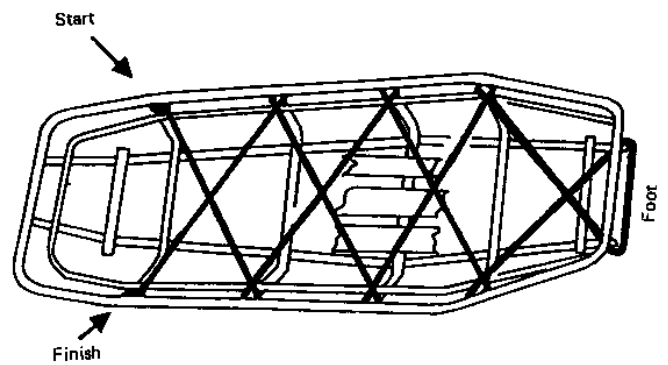
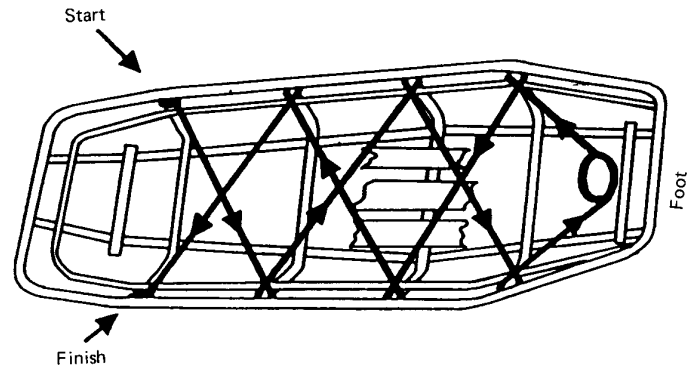

WRAP AROUND STRETCHERS

- Wrap around style stretchers such as the Paraguard and the Fallright Evacuation Splint, whilst quite different in design and construction, share the same critical feature:
- They conform very closely to the casualties body, thus adding very little width or bulk for confined space operations.
- Each of the wrap-around style stretchers has its own advantages and disadvantages that must be weighed up prior to use.
- Each has its own individual casualty securing system. Manufacturers' recommendations about methods of attaching lowering and guide ropes must be followed.

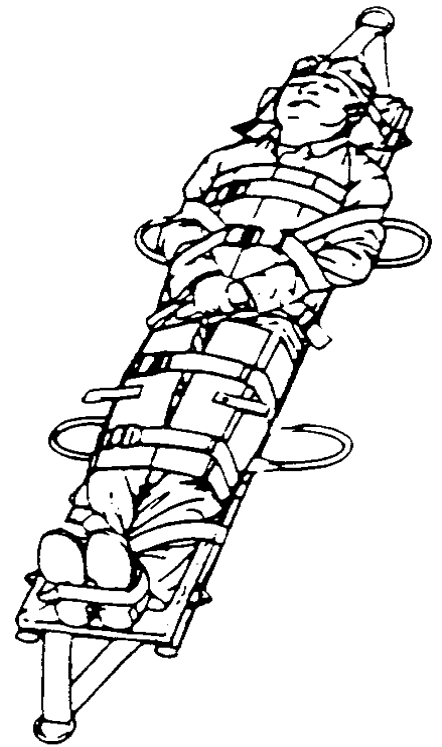

MOVING A STRETCHER OVER UNEVEN GROUND

A stretcher should, wherever possible, be carried in the horizontal position or slightly 'head high'. When moving over debris or uneven ground, this may prove to be difficult, but risks to both casualty and rescuers can be reduced to a minimum by adopting the following procedures:

Using Six Rescuers

Moving a heavy casualty over difficult debris conditions for any more than 10 or 15 metres, will almost certainly require 6 rescuers.

- The leader should position three on each side of the stretcher.
- On the order: **Prepare To Lift**, the rescuers stoop and grasp the stretcher. When all is in readiness, the leader gives the order: **Lift** and the stretcher is raised to waist height.
- The next order will be: **Prepare To Pass**. Any member of the team who for any reason is not ready should inform the leader.
- Good footing on debris is hard to find, and care should be taken in this regard.
- On the command: **Pass**, the stretcher is passed until such time as it is supported by four rescuers, leaving two spare.
- These two then climb carefully around the stretcher and take up positions at the other end of the stretcher.
- The process is then repeated until the stretcher arrives on clear, solid ground.
- It is stressed that this operation calls for a high degree of teamwork and that the leader must retain control throughout.
- The leader must ensure that while the stretcher is being passed, no member of the team is moving on the debris.

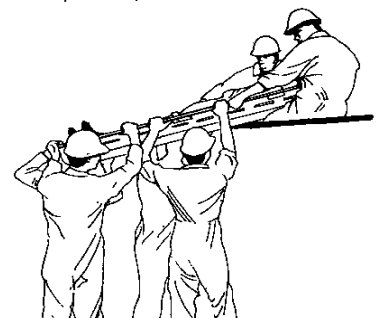
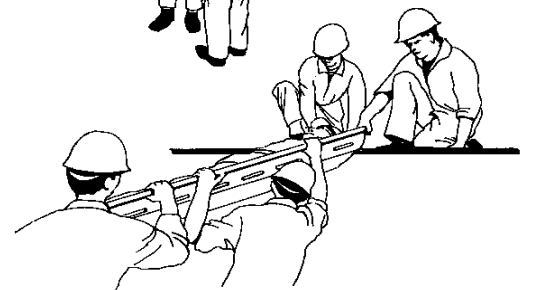
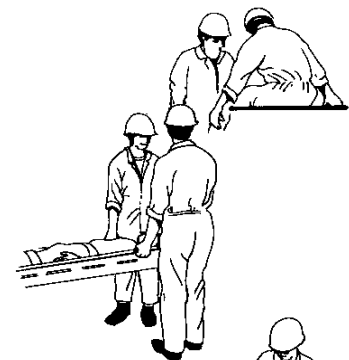
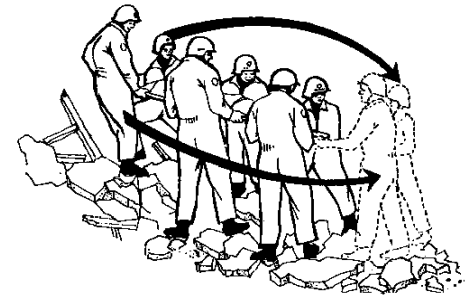

Using Four Rescuers

In this method the operation is carried out in a similar manner, except that where with six rescuers there were four to support the stretcher, while two changed their positions.

Using only four rescuers, two must support, whilst the other two move. It will be found of great assistance to those left supporting the stretcher, to get their thighs well braced under the stretcher. Not only does this relieve the weight on their arms, but also helps to stabilise the operation.

MOVING A STRETCHER IN CONFINED SPACES

In confined spaces, if there is sufficient height and the casualty has been lashed to the stretcher, it may be stood on end and moved around sharp corners.

- Where the height is insufficient to permit this method being used, a compromise between the vertical and horizontal positions is necessary.
- The casualty should be carried feet first as far as the middle of the right-angle bend, when the foot of the stretcher is placed on the ground and the head end lifted as high as the situation will permit.
- The stretcher can be worked around the bend, one rescuer easing the foot end and the other the head.
- Under these conditions the stretcher should not be tipped on its side. To do so would only increase its height and also the difficulty in handling it.



It should be obvious that 'wrap-around' style stretchers are specifically designed for combined spaces and that these should be used wherever possible.

PASSING A STRETCHER OVER A GAP

A large gap which has to be negotiated by rescuers can be overcome by laying an extension ladder across it being mindful of ladder load ratings, and, if possible, placing a decking of boards over the rungs.

Shorter gaps, such as in floors etc, can be patched, using timber from the site or possibly the short ladder.

Still smaller gaps can be traversed in a similar way to that described for moving over debris.

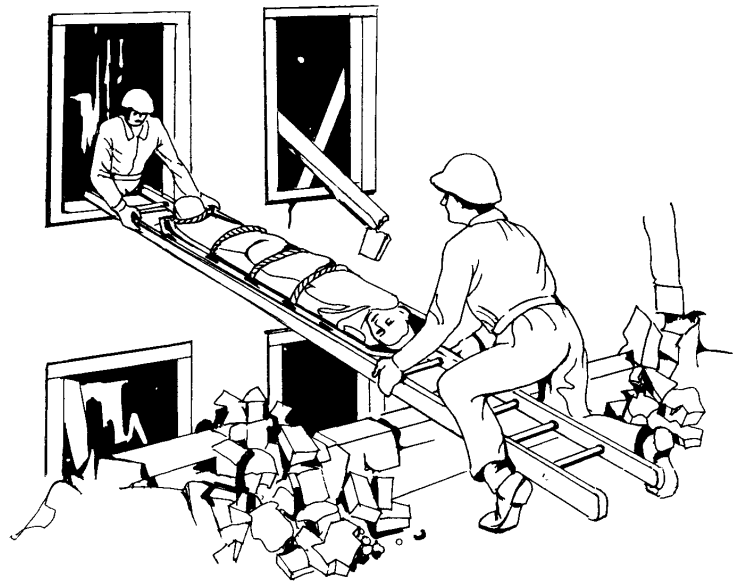

CHAPTER TEN

IMPROVISED CASUALTY MOVEMENT

RESCUE TECHNIQUES USING NO EQUIPMENT

This subject is covered under two headings:

1. One Rescuer Handling Techniques
2. Two Rescuer Handling Techniques

It must be clearly understood that the following techniques are for use in an **emergency** and that seriously injured casualties should, where possible, be placed on a stretcher.

Conditions such as fire or imminent danger of building collapse, may however dictate that removal from the scene is the first priority. In some cases this may even take precedence over life sustaining first aid.

ONE RESCUER HANDLING TECHNIQUES

One Rescuer Human Crutch

For this method to work, the casualty must be conscious and capable of giving the rescuer some assistance.

- Demonstration clearly indicates how the single rescuer human crutch is effected.
- Note the position of the rescuer's hands, one holding the casualty's wrist and the other taking a firm grip of the clothes at the waist on the far side of the body.
- The injured side of the casualty should be closest to the rescuer.



WARNING NOTE:

All single rescuer techniques involve the risk of Injury to the rescuer.

Pick-A-Back

This is an effective method when conducted correctly.

- When the casualty has been loaded (must be conscious), care should be taken to ensure they are supported well up on the rescuer's hips with the body literally draped across the rescuer's back.

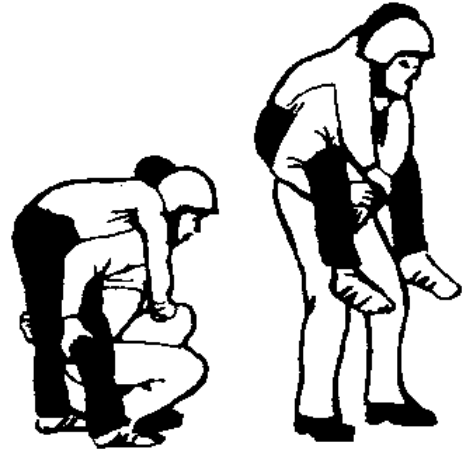

WARNING NOTE:

The rescuer effecting a pick-a-back or firefighter's crawl carry runs a significant risk of back injury and must take appropriate safety precautions.

Pack Strap Carry

This is used on the conscious casualty with no fractures of the extremities.

- Turn your back to the standing casualty.
- Bring their arms over your shoulders to cross your chest.
- Keep their arms straight as possible, the armpits over your shoulders.
- Hold casualty's wrists, bend, and pull the person onto your back.

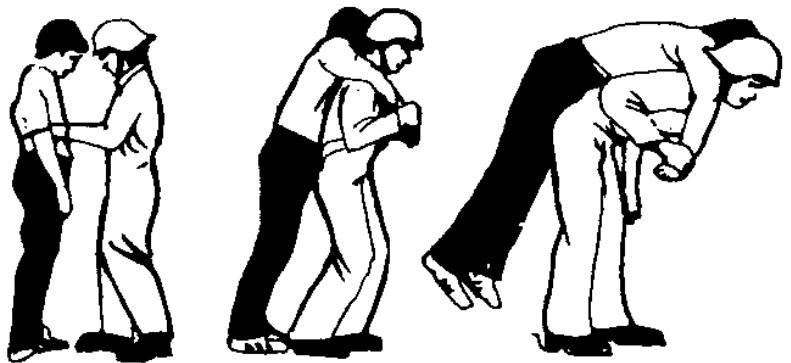

Fire-Fighter's Crawl

This is an invaluable method where a casualty has to be removed from a burning or smoke filled building.

- Both rescuer and casualty have their heads low down where the clearest and coolest air is to be found if the building is on fire.
- It is clear that the entire weight of the casualty does not have to be supported by the rescuer.
- The casualty's hands should be crossed over and tied with a bandage or similar.
- The Fire-Fighters crawl method can be varied according to personal preference. Probably the most effective method is for the rescuer to place an arm, shoulder and head through the casualty's arms as shown.

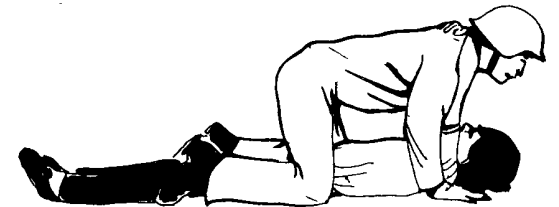
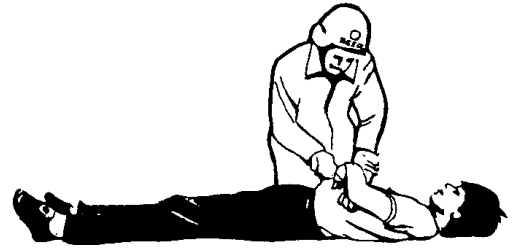

Removal Down Stairs Method

This method is used to recover a heavy casualty downstairs, when the rescuer cannot use the pick-a-back or other methods. However, its use need not be restricted to staircases.

- With the casualty lying flat, the first step is to tie the wrists together using a triangular bandage or similar.
- Next, the rescuer comes to the head and
- The rescuer reaches though under the casualty's arms and grasps the wrists.
- The rescuer is then in a position to drag the casualty backwards, and if a staircase has to be negotiated a large measure of support can be given to the casualty's trunk by the rescuer using a knee to ease over each successive step.
- It is well to remember that the strongest part of any staircase is close to the wall.

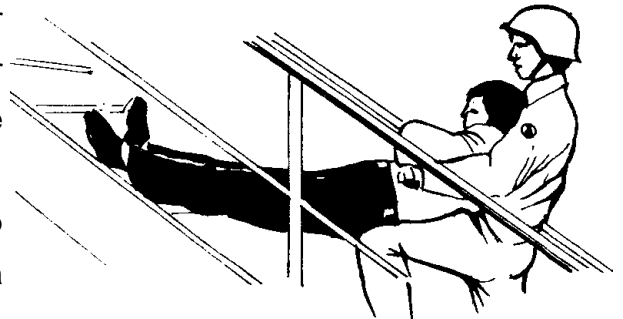

TWO RESCUER HANDLING TECHNIQUES

Two Rescuer Human Crutch

This method is similar to the One Rescuer Human Crutch, except that the casualty is supported on both sides with the arms of the rescuers' crossed over on the casualty's back and grasping the clothing on the opposite sides of the body.

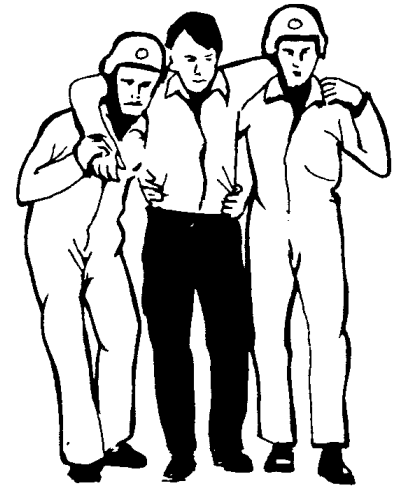

Two-Handed Seat

- Rescuers kneel on either side of the casualty, get them into a sitting position, place one arm under the knees and link up with the hand to wrist grip.
- Their forearms are then crossed over the casualty's back, where they get a firm grip of the clothing or link arms across casualty's back.
- The leader should give the normal orders for lifting and lowering.

Three-Handed Seat

This method gives the casualty good support and is reasonably comfortable for the rescuers. It has the added advantage that the two rescuer team has a spare hand for steadying.

- One rescuer grasps their left wrist with their right hand and the second rescuer places their hands as shown.
- This forms a seat. If the casualty is capable of standing for a short period they can be loaded by placing the seat under the buttocks, but if not, the rescuers' hands must be placed under the casualty's knees first, then joined up.

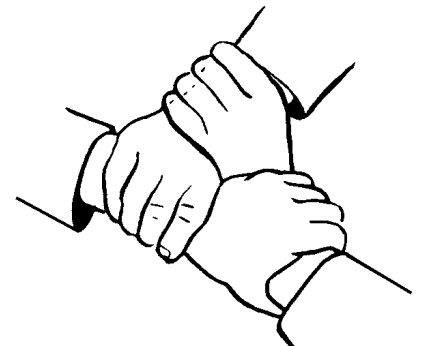

Four-Handed Seat

This is a method where each rescuer grasps their left wrist and the hands are joined up.

This provides a comfortable seat for the casualty and places a minimum strain on the rescuers. However, the casualty must be sufficiently conscious to hold on.

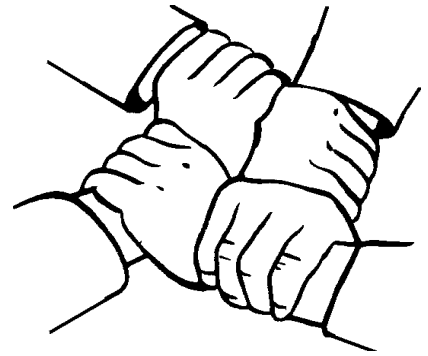

The 'Fore and Aft' Method

This is perhaps the most suitable way in which two rescuers can handle an unconscious casualty.

- The casualty is prepared in the same way as for the removal down stairs method ie: the wrists are tied together.
- The first rescuer stoops at the rear of the casualty. Reaching under the casualty's arms, the first rescuer grips the casualty's wrists.
- The second rescuer stoops between the casualty's legs grasping them underneath the knees.
- The standard lift orders are given and the casualty is lifted into the carrying position.
- Should the casualty have a leg injury, the effects of this can be minimised by the front rescuer crossing the casualty's legs over, then carrying them to one side.
- The advantage of this method is that the rescuer supporting the casualty's feet has a free hand with which to open doors, clear debris, etc

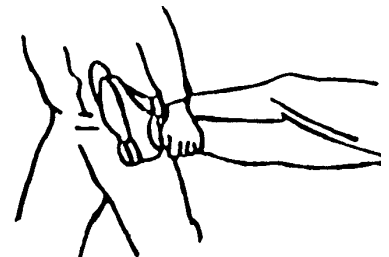
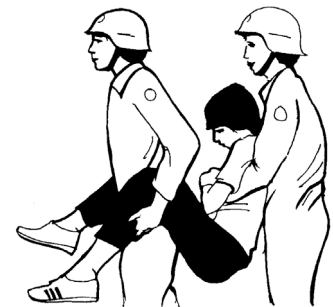
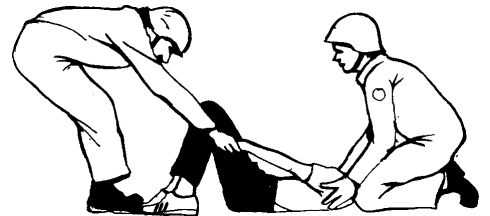

It is again stressed that the foregoing one and two rescuer techniques are generally confined to emergencies where removal from the scene is the first priority.

IMPROVISED STRETCHERS

In any disaster, there may be insufficient stretchers immediately to hand for the number of casualties involved. Such situations will normally be multi-agency responses, and the resources of all involved agencies should be brought to bear on the problem.

There are many methods of improvisation and some imagination should be used when confronted with the problem. However, a number of the more obvious methods are described here.

Platform Stretchers

Improvised platform stretchers can readily be devised from doors, sheets of galvanised iron, or bed frames.

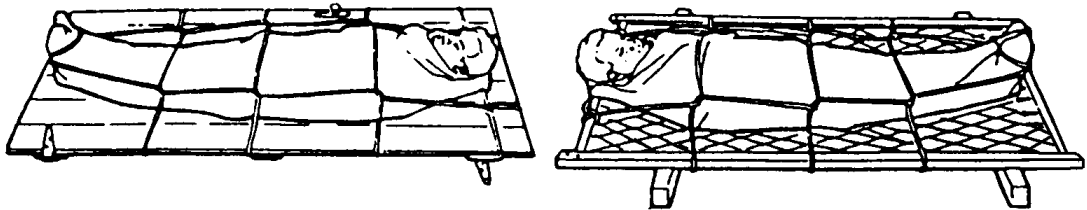

Pole Stretchers

These stretchers are very simple to make and require two poles about two metres long. Stout broom handles, water pipe or 50mm x 25mm timber are quite appropriate for this job.

The poles should be laid parallel on the ground and about 600mm apart. The bed of the stretcher can be formed from a blanket, sacks, overalls, or coats.

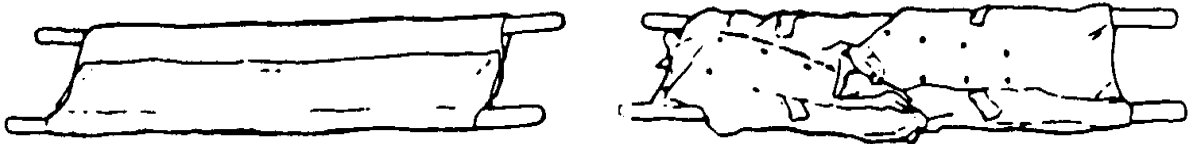

Bush Stretchers

A bush stretcher can readily be devised from two timbers about 4 to 5 metres long, strutted and lashed together. This is not a makeshift stretcher by any means, and in bush country may be the only suitable means of carrying an injured casualty over long distances.

With the casualty supported on the rope lashings, up to 8 rescuers can carry the stretcher at shoulder height over rough ground and bush, thus avoiding many of the obstacles normally in the way of conventional stretchers.

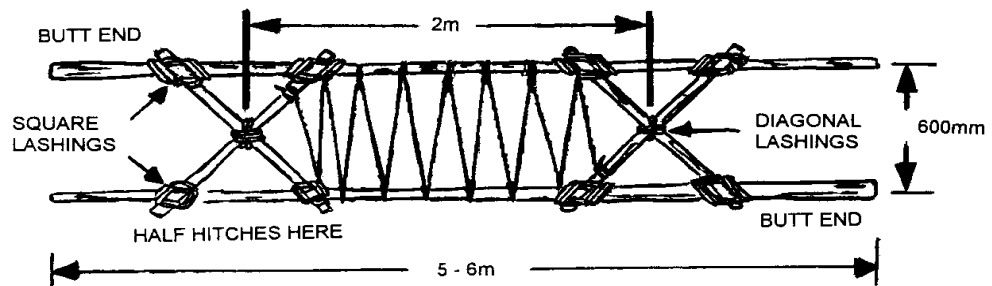

Ladders

Where for any reason, a very narrow stretcher is required, such as for passing through small window openings, tunnels etc. a small ladder or one half of a small extension ladder can be used to an advantage

A decking of boards should be placed on the ladder (if available) and it is then blanketed in the normal way.

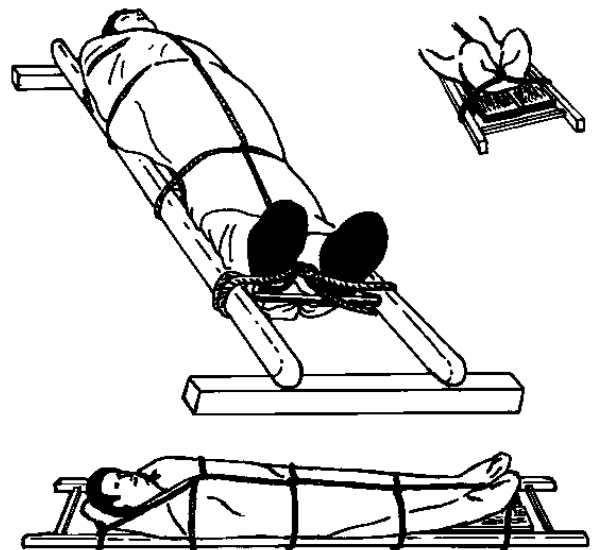

Chairs

A **strong** style kitchen chair can be used for carries of casualties without serious injuries.

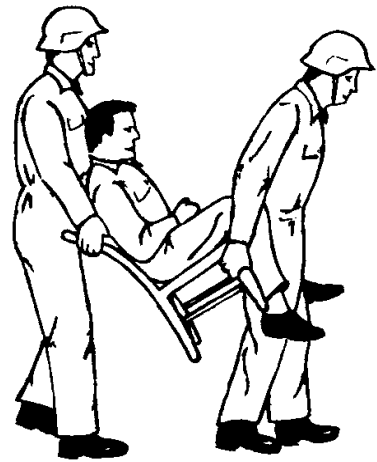

CHAPTER ELEVEN

LIFTING & LOWERING TECHNIQUES

INTRODUCTION

In any disaster occurring in an urban environment, it can be assumed that large numbers of casualties could be trapped in upper floors of buildings, in basements or other depths, or many other difficult or inaccessible areas. In each case, the method of rescue will be dictated by the circumstances and this chapter attempts to provide some of the alternative methods of rescue often used. The simple option of carrying a casualty up or down an inside stairway must never be overlooked.

It must be stressed that the techniques included here are very basic. More technical systems (requiring a higher level of training and expertise) can be used in many circumstances.

Additionally, a number of improvised techniques are included in this chapter. They are, in the main, those simple techniques which utilise materials found or acquired on a disaster site, and which can readily be used to effect rescues.

MECHANICAL LOWERING METHODS

Basic vertical rescues can readily be carried out using equipment such as Karabiners, descenders, and climbing tape. These techniques are best effected using 11mm static rescue rope.

STRETCHER OPERATIONS

The recovery of an injured person requires the bringing together of a wide range of rescue skills with the use of rescue stretchers. **Where any doubt exists as to the casualty's injuries, a stretcher must be used.**

Depending on the injuries, terrain and conditions, a casualty can be recovered in a horizontal or a vertical attitude. Wherever possible, it is recommended that casualties be recovered in a horizontal attitude.

GUIDE AND SAFETY LINES

Two guide lines may be attached to stretchers during lowering operations to prevent the stretcher from spinning, and in order to clear obstacles. These guide lines are attached to the head and the foot of the stretcher for maximum control. Rescuers controlling guide lines should wear gloves. Safety lines should be attached to the stretcher as an added safety measure and belayed from above.

IMPROVISED SINGLE POINT LOWER

This improvised method should only be used when, because of fire or other emergency combined with a lack of equipment, immediate evacuation of the casualty is imperative.

The technique uses an 11mm rescue rope and a casualty support knot or a stretcher, and consists of taking two round turns around a sound anchor point as a belay.

The rope should be paid out hand-over-hand and the rescuers must wear gloves.

A more satisfactory single point lower technique can be achieved with a mechanical descender.

Where a descender is not available, it is desirable that at least two rescuers control the lowering rope.

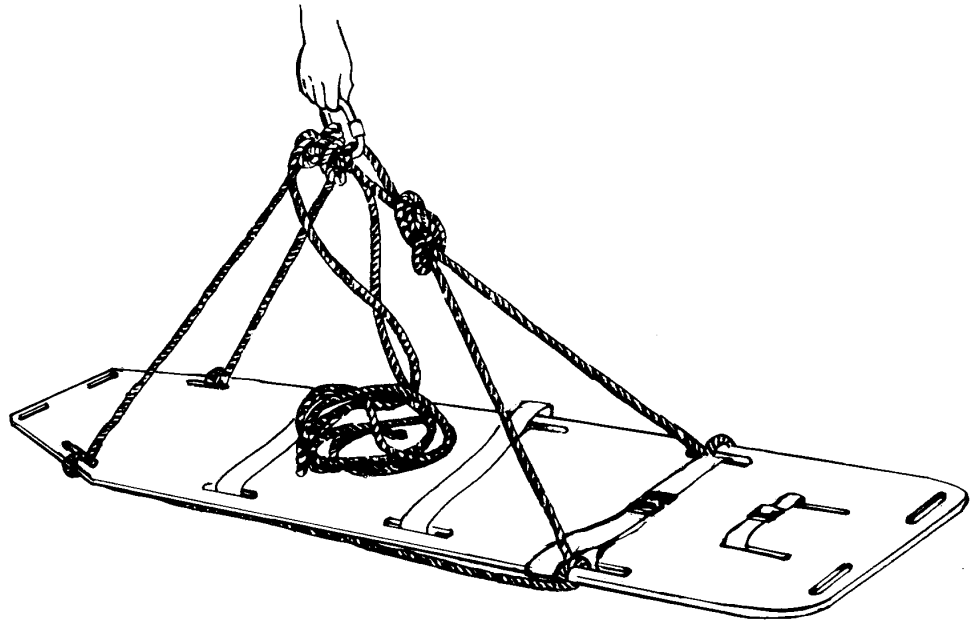

TWO-POINT VERTICAL SUSPENSION

This method is used for raising or lowering a stretcher over relatively short distances, and where the casualty's injuries allow for transport in a vertical attitude.

WARNING NOTE:

The use of folding (Furley or Mark 2) stretchers for rescues should only be considered as an improvised technique where no other stretcher is available.

The casualty is blanketed and lashed to a stretcher in the normal way, with the addition of a bandage tied across the forehead to prevent the head flopping forward should the casualty become unconscious.

- When using Basket or Board Rescue stretchers, the lowering ropes and guide lines are tied to the stretcher by means of a Rethreaded Figure 8, and a _ Hitch.
- The same procedure is used for the foot of the stretcher and the guidelines are passed out to the two rescuers on the ground.
- The two rescuers above ease the stretcher over the edge of the wall, until such time as they come to the lowering lines with which they lower away hand-over-hand.
- The two rescuers on the ground guide the stretcher clear of any obstruction and walk in on the guide lines to support the stretcher on either side as it comes down.
- This technique can be used equally well inside a building, using a hole found or cut in the floor.
- If possible, do not cut through floor joists as it takes longer and weakens the whole structure.
- Four rescuers form the ideal team to do the job.
- Additional personnel can assist in lowering the casualty.

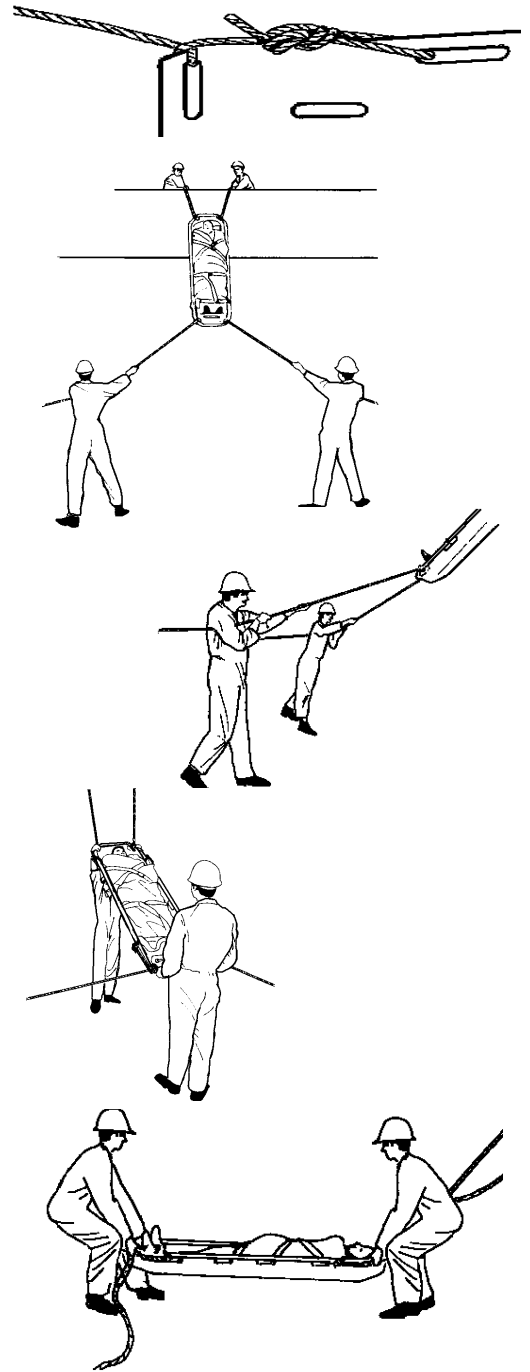

FOUR-POINT HORIZONTAL SUSPENSION

Where it is essential to keep the casualty horizontal, and where injuries permit, the four-point horizontal suspension can be used with any rescue stretcher.

- The stretcher is rigged and lowering lines are attached in exactly the same way as for the two-point suspension, except that it is advisable to use separate ropes for each 'corner' of the stretcher.
- A suitable hole must be found or cut in the floor and the stretcher is then lowered.
- The rescuers on the far side pull the stretcher across until it is located over the centre of the hole.
- Four rescuers are required, unless the casualty is very light, in which case one rescuer positioned at the head and one at the foot of the stretcher can do the job, each controlling two ropes.
- If no suitable landing is available for the stretcher below, two rescuers will be required to receive the stretcher.



NOTE: Safety lines must be fitted to all rescuers working at height, adjusted to ensure that they do not fall down through the hole. These must be fastened to suitable anchors.

LADDER HINGE

WARNING NOTE:

This is an improvised rescue technique.
The ladder is used in a manner other than for which it was designed
and manufactured.

This is a relatively simple method of rescuing a casualty from an upper floor, when it is desirable to keep the stretcher horizontal, or the upper building is so unstable that it cannot be used to assist in the operation. It should be noted that the ladder is used with its reinforced side **away** from the structure.

- The casualty is blanketed and lashed to a stretcher in the normal way.
- The ladder is placed vertically against the wall in front of the opening.
- One rescuer supports the head of the stretcher, while another lashes the foot of the stretcher to the ladder about 250mm above the window opening, using a short length of rope or tape and Karabiners can be used.
- Rethreaded Figure 8 is tied to the stretcher in the same manner as for a Two Point Suspension.
- The rope is then taken around the stile of the ladder in a Half Hitch and the stretcher is raised until it is about 250mm clear of the window sill.
- Six to eight round turns are taken around the ladder rung, the rope is Half-Hitched to the stile on the opposite side of the ladder, and finally secured to the other side of the stretcher using a Round Turn and two Half-Hitches.
- Alternately, webbing and Karabiners can be used, as shown.
- This hitch is used so that the stretcher may be adjusted for lateral balance.

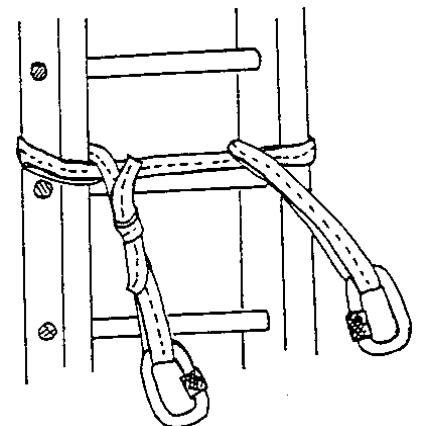
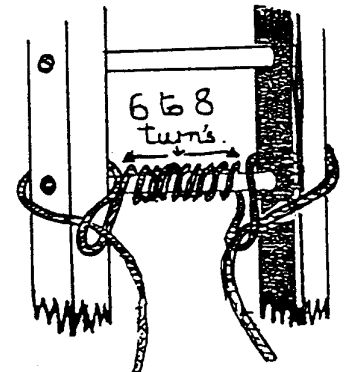

- Lowering lines are attached to the head end of the stretcher, and when all is secure, the word is passed to the leader who gives the orders: **Prepare To Lower** and then: **Lower**.
- The stretcher is passed out of the window by hand until the head end can be supported by the lowering lines.
- Two rescuers remain close to where the ladder has been footed, ensuring no side-sway develops.
- One rescuer then walks backwards, hand-over-hand with each rung, controlling the speed of the whole operation.
- The stretcher should finally come to rest on top of the ladder flat on the ground, from where it can be quickly disconnected and the casualty removed to safety.

NOTE: this method can also be readily used to raise a casualty.

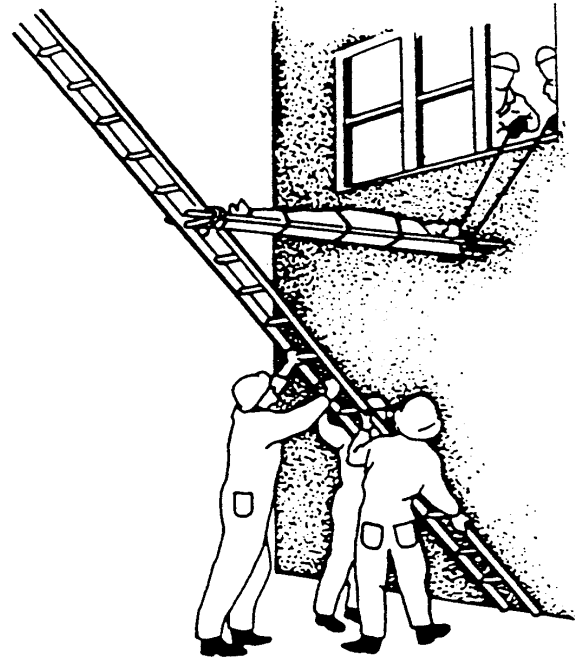

WARNING NOTE:

Where timber ladders are used for ladder hinge or ladder slide techniques, the ladders must be reinforced with wire or fibreglass to support the stiles.

LADDER SLIDE

- The casualty is blanketed and lashed to a stretcher, and two lowering lines are secured to the head end.
- The ladder is placed in position by three rescuers at as steep an angle as possible.
- One rescuer foots the ladder and one or two act as human props.
- The rescuer climbs the ladder.
- The foot of the stretcher is passed out onto the ladder.
- The stretcher is then moved down the ladder until such time as the head end passes clear of the opening.
- The stretcher is slid down the ladder, guided by the rescuer.

NOTE: This is a technique that can also be used to raise a casualty to safety.

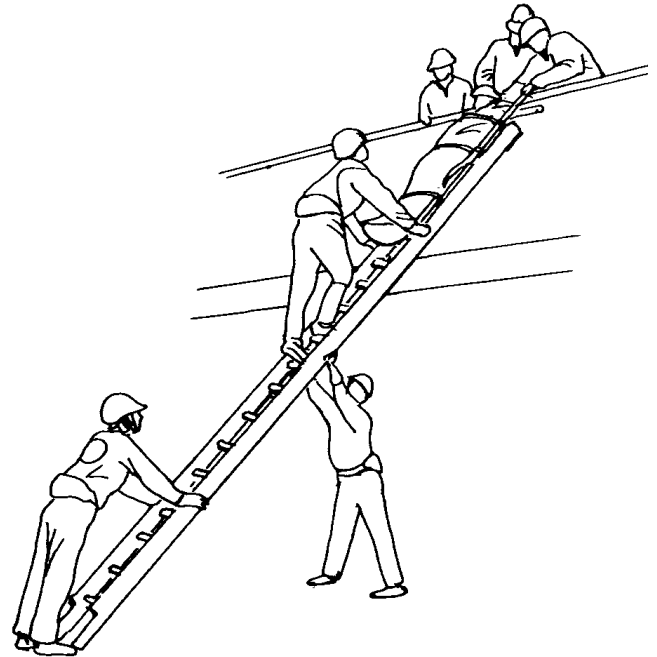

WARNING NOTE:

In the ladder slide technique, the ladder is used in a manner other than that for which it was designed and manufactured. This is an improvised technique. As the load on the centre of the span will be close to 150kg, the span must be propped by one or two rescuers, or shored.

Some specific points to be observed with the Ladder Slide are:

- Where a timber ladder is used, it must be reinforced with wire or fibreglass stile supports.
- Where a basket stretcher is used on an alloy ladder, there will be very little friction, providing a rapid descent.
- The ladder must be set at as steep an angle possible for safety.
- Where ladders are extended to provide sufficient reach, the overlap should be lashed with short rope or cord.

LADDER DERRICK

This technique has particular application where the structure from which the casualty has to be removed is so unstable that it cannot be used in any way to assist the operation. In this situation the ladder derrick is self-supporting and does not depend on support from the building in any way. A Team of 9 Rescuers is recommended for this techniques, with an absolute minimum of seven.

- Set up the head of the ladder with guy ropes, and pulley. A shackle or Karabiner may be substituted for a pulley.
- A rope is then secured between the two top rounds and tied with a Rethreaded Figure 8. This is used as the back guy, and carries the main load.
- A 12m lashing is halved, and then two Half-Hitches are applied to the top of the ladder string. This is on both sides of the ladder. These two lines are then crossed, and become the side guy ropes. Additional 12m lashings may need to be joined to them to reach the pickets
- An appropriate length rope is passed through the pulley, and is used as the lowering line. The standing end of this line passes down the inside of the ladder and under the bottom round. A Friction Hitch may be applied to the bottom round to provide additional control.
- Three sets of picket holdfasts are driven to support the back and side guys. If possible, the sides guys should be located in front of the point where the ladder is footed.
- The ladder is now ready to be erected, under the control of the leader.
- The ladder is raised using a three-rescuer raise technique. All guy ropes should be controlled at this stage.
- Once raised, the ladder is extended to the required height, and after being levelled-up, the guy ropes are secured using a Round Turn and Two Half-Hitches on each.

It is recommended that the foot of the ladder be secured to pickets.

At all times while the Derrick is under load, the pickets must be carefully watched to ensure that they do not pull out.

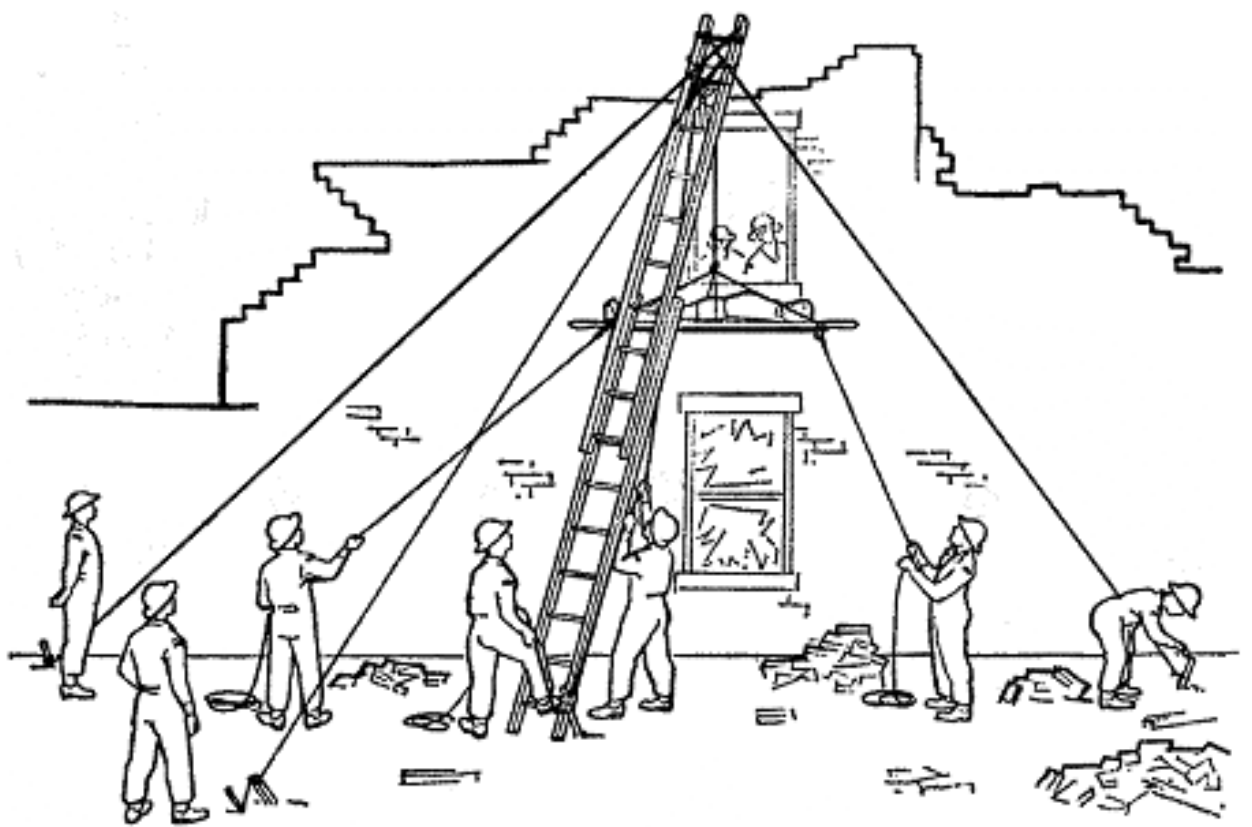
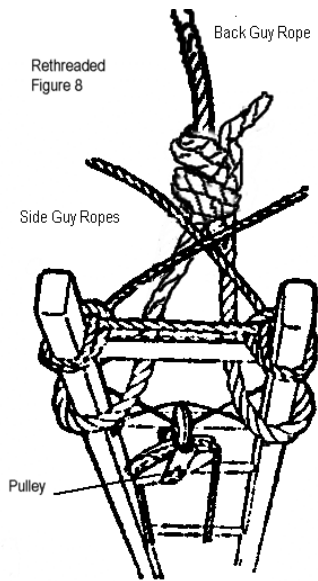

THE JIB

- The jib consists of a pole projecting about one metre horizontally out from a structure. A snatch block or pulley, with a lowering line passed through, is attached to the end. It is a quick method of lowering stretchers in a horizontal position.
- The material used for the jib must be strong enough to allow the one metre projection to bear all weight.
- Before pushing the jib pole out, the pulley must be secured by tying a pulley to the pole.
- Alternatively, the pulley can be safely and rapidly secured to the jib by means of tape slings and a Karabiner.
- It is important that the lowering rope is passed through the block or pulley, in such a way that the running end goes directly to the lowering party, and the standing part goes to the stretcher. The rope should not cross.
- The pole must then be firmly lashed into position, making sure that the pulley is in the centre of the opening and not more than 1m out from the wall in order to reduce leverage on the jib.
- It is important that the pole be lashed as near as possible to the point where it passes over the wall as side strains will often be set up during the lowering operation.
- The other end of the pole must be secured.
- Remember this end of the pole will tend to lift, and this must be borne in mind when selecting an anchorage.

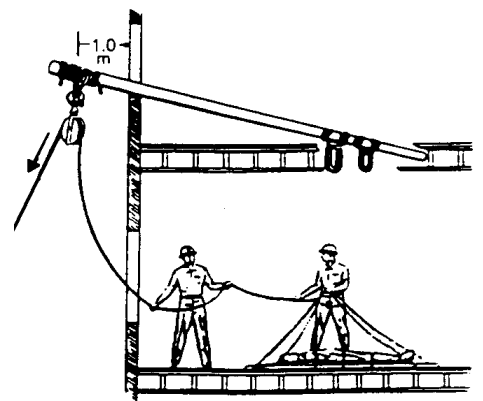
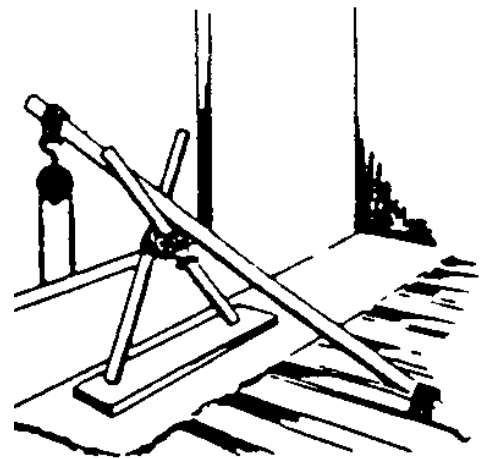
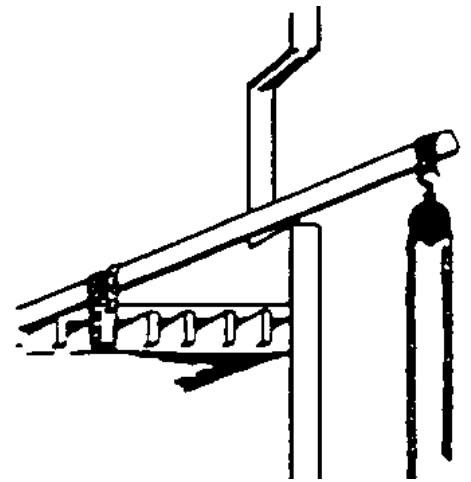
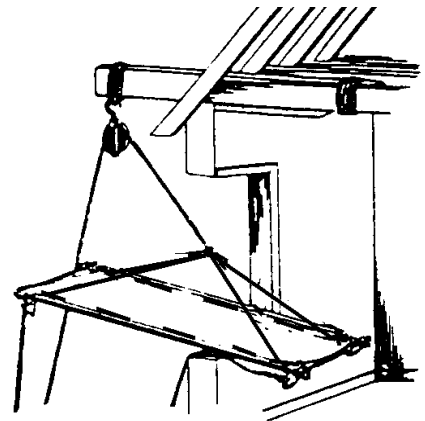

- It is not necessary that the pole should be at right angles to the wall or that it should be in the horizontal plane, (eg: the inside end of the pole could be anchored down to a floor joist, if it were solid).
- The casualty is blanketed and lashed in the usual way and secured to the rope end in the appropriate manner.
- Two guide lines are attached to the stretcher and passed down to the rescuers on the ground.
- A friction-lowering device is secured to an appropriate anchor point and the lowering operation is controlled by a rescuer letting rope out slowly and carefully through the device.
- When a lowering device is not available, at least two, preferably three, rescuers will be required on the lowering rope.
- When all is ready, the weight is taken on the lowering rope and the two rescuers up top ease the casualty out through the opening, feet first.
- As soon as possible the rescuers on the guide lines swing the stretcher around parallel to the structure and lowering commences.
- Where necessary, the guide line rescuers can pull the stretcher out to a clear landing space as it comes down.
- They should walk in on their lines so as to be ready to take hold of the stretcher as it comes in reach.

TRIPODS (OR GYNS)

- A tripod consists of three poles lashed together near the heads and with the butts forming an equilateral triangle on the ground.
- No guys are required and the space occupied is small, but only a vertical operation is possible.
- A lateral pull or loading will de-stabilise the tripod and may cause its collapse.
- The poles used should be of roughly equal length and strength.

Layout and Preparation

- The three poles should be laid out side by side, the butts flush on the ground.
- They should be marked about 1metre down from the head of the shortest pole to show the position of the centre of the lashing.
- The centre pole should then be reversed and the head placed between the heads of the other two so that all three marks are in line.

- Spacing pieces 50mm thick should be inserted between the poles, and the poles lashed together with a Figure 8 lashing.

- The spacer blocks are then removed and the two outer poles are crossed until their butts are at a distance apart equal to about half the effective length of the poles, the top of the centre pole to rest in the fork of the other two.

- A sling is placed in the fork of the tripod in such a manner as to bind the poles together when the weight is taken, the lashing being suitably protected.

- The upper pulley is secured to the sling. The tackle is prepared and overhauled to the required length.
- The lower pulley is temporarily lashed to one of the legs to prevent swinging.
- The hauling rope is passed through a leading pulley secured to the butt of the pole.

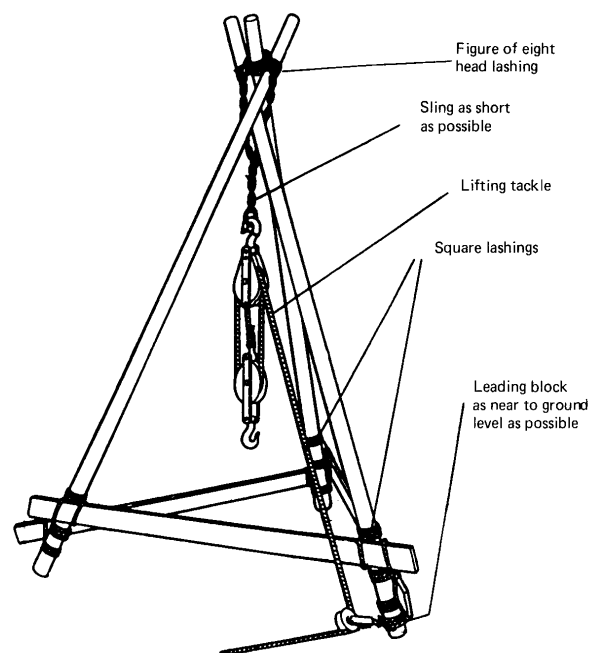

Raising

- The head of the tripods should be lifted as far as possible by hand and the centre pole brought in to form an equilateral triangle.
- The butts should be evenly spaced at a distance apart equal to about half the height from the butt to the lashing. They must all be on the same level or the weight will be distributed unevenly, and the tripod must be placed so that its head is as near as possible over the centre of gravity of the load.

Securing

Whether a load is suspended or not, the tripod should not be left standing unless the butts are secured against slipping.

CHAPTER TWELVE

PULLEY SYSTEMS, WINCHES & LIFTING EQUIPMENT

PULLEY SYSTEMS

Pulley systems are used to gain a mechanical advantage in hauling, lifting, and lowering operations.

A system is formed by threading the pulleys with rope, and all rescuers should be thoroughly familiar with the correct terms, applications, capabilities, and maintenance of this equipment.

The traditional forming of ropes and pulleys into block and tackle systems has largely been overtaken by the more modern Z-rig pulley techniques utilising Kernmantel rescue ropes and lightweight high strength rescue pulleys.

TERMINOLOGY

Heave Or Haul

The act of pulling on the running end of the tackle rope to operate the tackle.

Mousing

Securing the hook of a pulley.

Pulley

A sheave in a frame or shell, provided with a connection point by which it may be attached to another object.

Redirection Pulley

A pulley used in a system to change the direction of the pull without affecting the mechanical advantage.

Running End

The free end of the fall or rope to which the pulling power is applied.

Running Pulley

The pulley attached to the object being moved.

Sheave

The grooved wheel over which the rope is run in a pulley.

Shell

The frame or part of the pulley which holds the sheave and to which the strap, hook, or eye is attached.

Snatch Block

A single sheave pulley with an opening or gate in one side of the shell, through which a rope can be engaged or 'snatched' into the sheave without threading the end of the rope through. This opening is secured by means of a hinged or pivoted portion of the strap.

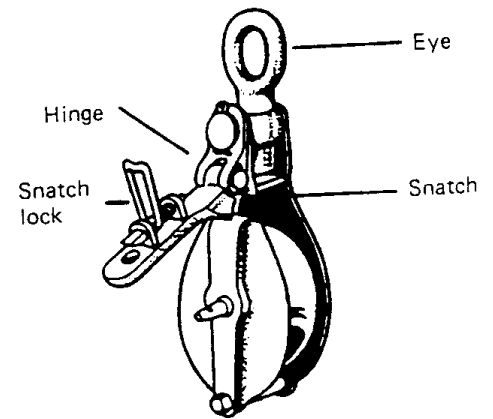
**Standing Block**

The system pulley which is fastened to an anchor.

Strap Or Cheek

The side plate of the pulley to which the hook or eye is attached.

Swing Cheek Pulley

A pulley design in which the side plates or cheeks can be pivoted on the axle to open the pulley and permit access for the rope to the sheave.

TYPES OF PULLEYS

The pulleys normally used in rescue systems are:

- Single sheave pulleys
- Double or two sheave pulleys
- Triple or three sheave pulleys
- Snatch block.

Sheave size and shape are important to safety. The diameter of the sheave must be such that the rope is not turned too sharply or it will be damaged, and particularly with steel wire ropes, the shape of the sheave groove must be correct for the rope.

CHARACTERISTICS OF A LIGHTWEIGHT RESCUE PULLEY

Lightweight rescue pulleys should be of swing cheek design and have the following characteristics:

- The sheave should have a diameter at least four times the diameter of the rope.
- The cheek plates should be moveable so that the pulley can be placed on the rope at any point without having to feed the rope through. They should also extend beyond the edge of the sheave to protect the rope from abrasion.
- The axle should have rounded ends which will not snag on ropes, other gear, or objects.
- The bearings should be of such construction as to allow the sheave to turn freely when loaded.
- A rated strength in excess of 1500kg, and preferably greater than 2500kg.

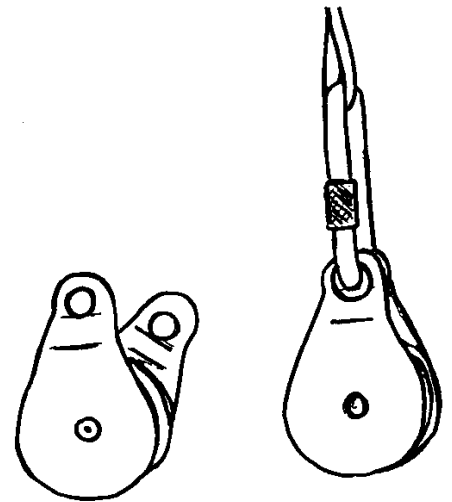

CONSTRUCTING PULLEY SYSTEMS

A modern lightweight pulley system such as the theoretical 3:1 rig is best built in place. The load line is brought to the anchored pulley, passed through it, and forward to the moving pulley, through the moving pulley, and back to the running end.

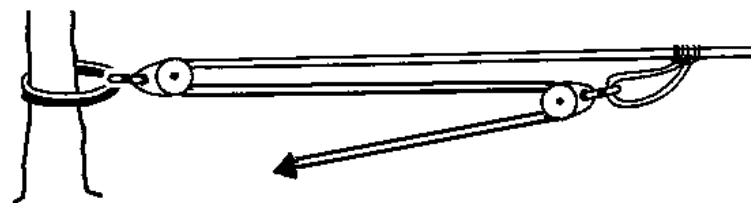

TYPES OF PULLEY SYSTEMS

A **lifting system** is one in which the load is attached to the running (lowest) pulley, and with the running end of the fall coming off the standing or upper pulley. When calculating the capability of a lifting system, it must be realised that the only returns between the pulleys assist in the lift, and that the running end does not help the lift at all.

Power is applied to the running end, and in the opposite direction to the direction in which the load is to be moved.

A **hauling system** is one in which the running end of the fall comes off the running pulley (to which the load is attached), and the standing pulley is made fast to an anchor of appropriate capability.

MECHANICAL ADVANTAGE

The **Theoretical Mechanical Advantage (TMA)** of a pulley system can be calculated by counting the number of sheaves or the number of returns in the system. For a system involving five sheaves, the TMA would be expressed as being 5 to 1 (or 5:1).

The **Actual Mechanical Advantage (AMA)** is less than the theoretical one due to the amount of friction caused by the ropes passing over the sheaves or contacting each other in the returns. The actual efficiency of the pulleys in the system is also taken into account.

IMPROVISED HOOK MOUSING

Wherever possible pulley hooks should be fitted with automatic mousing devices to prevent the load from jumping the hook. In the event that a plain hook pulley must be used, the following improvised mousing technique should be utilised:

- The mousing twine is used on the bight for speed of application and strength.
- The twine is first hitched to the hook above the bulge of the shank so that it cannot be pulled downwards.
- It is then led towards the bowl of the hook, being fixed to the shank again by one or more Half Hitches prior to the formation of the first Figure 8 or diagonal lashing turns.
- These are passed around the hook on alternate sides of the sling eyes.
- At least two Half Hitches are passed around the diagonal turns and inside the eyes of the slings to prevent the bights of the diagonal turns from sliding over the bill of the hook.

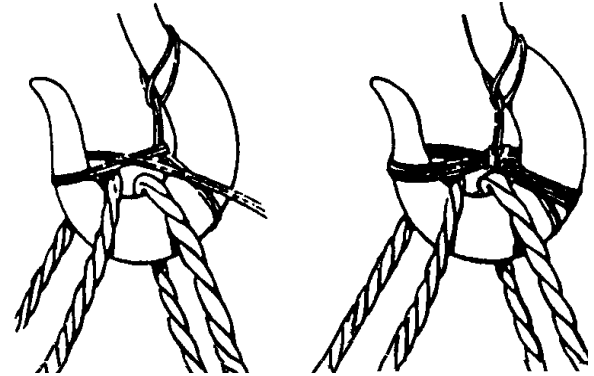

PRECAUTIONS IN OPERATIONS

The following safety factors must be observed when working with pulley systems:

- Pulley sheave sizes must be appropriate to the rope used.
- The fall must be free from kinks and twists, and must run easily over the sheaves.
- All fastenings must be securely made.
- Pulley systems must be carried, never dragged on the ground.
- All hooks must be properly moused.
- Suspended weight must always be eased off gently and never lowered in jerks.
- Rescuers must haul or lower in unison, positioned on alternate sides of the running end of the rope to keep the pull in a straight line using the hand over hand method.

- The returns near the pulleys should not be touched when they are moving, as the rescuer's hand may be trapped by the rope and drawn into the pulley.
- Not more than one tackle should ever be attached to either the load or the anchor sling.
- Pulleys must be well maintained, carefully handled, and kept free of dirt and grit, with all working parts sufficiently oiled to ensure free movement.
- Snatch blocks or single sheave blocks should be used on the running end of the system as redirection pulleys wherever possible. This will change the direction of haul to the horizontal, so that the rescue crew can work to best advantage.
- When using snatch blocks, check safety pins are secured.
- All anchor points should be capable of supporting the total load involved.

LIFT / LOWER ROPE RESCUE DEVICES

A number of pre-rigged lift/lower rescue devices are readily available on the commercial rescue market. These systems operate either as traditional pulley rigs, or as friction drums or capstans. The devices are therefore easily categorised as either **pulley systems** or **drum systems**.

Pulley systems

These rigs are identical in design and operating principles to conventionally reeved pulleys, with the most common configuration being a 4:1 TMA. Several models are fitted with a rope brake cam in the shell of the anchored pulley, allowing for the final rope return to be secured between hauls. This cam can be 'tripped' by an accessory cord for lowering operations. Devices such as the Rescue Master operate on the same principle but use a special inertial brake pulley.

Systems such as the 'Haulsafe' and the 'Rescuemate' utilise lightweight rescue pulleys, and can readily be rigged with a length of rope that is appropriate to the most common application within the agency's area of operations. The entire kit can then be stored and carried in a rope pack ready for deployment on all lift/lower/haul tasks.

Drum systems

Drum controlled systems such as the 'Griptech' and the 'Rollgliss' provide friction for a controlled lower by means of the number of turns of rope formed around a rolling drum. They can be used with or without a travelling pulley, and in general provide a lower theoretical advantage for lifting/hauling than do the pulley systems.

OPERATIONAL USAGE – STANDARD PROCEDURES

- The device should be constructed with a length of rope which is sufficient for normal applications in the area of response. This must take into account the rope required to form the returns required for the specific device.
- When used for life rescue purposes, the device should be rigged with rope that complies with New Zealand Standard AS4142.3:1993 - Static Rescue Lifelines.
- The devices must be used strictly in accordance with the manufacturer's guidelines.
- These systems can be anchored overhead for direct lift/lower operations, or can be used for horizontal hauling. When used horizontally, additional care must be taken to ensure that the device is clear of all contact.
- Safety brakes or cams must be active or fitted for all lift/haul operations.
- Standard procedures must be followed with respect to anchoring, crew operations, commands, and the wearing of gloves.

WARNING NOTE:

For all mechanical winches, when SWR is under load, a heavy blanket or similar should be placed across the rope so as to identify rope location and in case of failure of rope will assist as a rope brake.

TIRFOR STYLE WINCHES

This style of winch consists of a machine or casing through which passes a long steel wire rope which is attached to the load to be hauled or lifted. The operation of a lever handle backwards and forwards pulls the rope through the machine, which if properly anchored, causes the load to be hauled towards the machine.

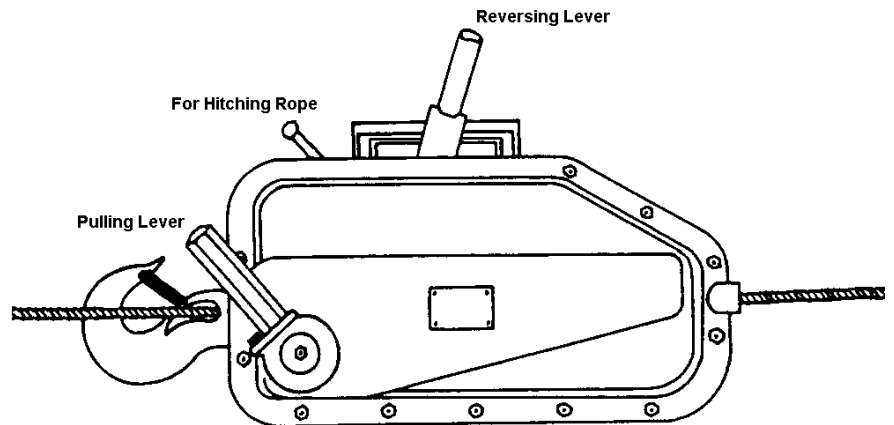

As a device for lifting or hauling, the machine has innumerable uses and applications. Being light and compact, it can be attached to any convenient holdfast or hung from overhead beams or girders, slung from or attached to derricks or 'A' frames, or even attached to the load itself if the rope end is anchored to an immovable object.

The rope enables the load to be lifted, lowered, or hauled considerable distances without changing the position of the machine and in conjunction with the SWR blocks, permits the most convenient position to be selected for fastening the machine. The rope can then be taken over the pulley, through window or door openings, or down through floors to wherever the load may be. It can also be passed over a block, at the head of a derrick or 'A' frame, to obtain height for raising loads.

WARNING NOTE:

Do not step over or stand near a winch rope which is under tension.

The back lash from a broken cable can be fatal.

Keep clear of loads being winched.

The Tirfor Kit

The Tirfor winch kit consists of:

- A pulling and lifting winch unit complete with a swivel hook to enable it to be secured.
- A detachable telescopic tubular steel handle for operating the unit.
- A length of flexible steel wire rope fitted with a hook at one end, the other end being tapered and fused. (This rope is coiled on to a reel for convenience in carriage).

The machine unit consists of a steel casing enclosing two pairs of automatic jaws which grip the steel wire rope passing through the casing. These two pairs of jaws are moved in opposite directions by means of linkages when the handle is operated backwards and forwards. This alternating operation of the handle results in a hauling or lifting movement in the rope.

WARNING NOTE:

Tirfor style winches must be operated and maintained in accordance with manufacturers' guidelines.

Precautions In Tirfor Operations

If a single operator cannot move the load with the telescopic operating handle fully extended; the load is too great for the machine and a steel wire rope block should be used to increase the mechanical advantage.

- The operating handle must not be extended in any additional way.
- Always use slings and anchors of sufficient strength to withstand the load.
- Keep the wire rope wound on to the reel when not in use.
- Never allow any kinks in the rope to enter the machine as this causes internal damage.
- Only use the wire rope supplied with the machine.
- Never anchor the machine by the tip of the hook; always use slings.
- Never apply tension to the running end of the rope.
- Never step or stand over a wire rope under tension, and remain clear of the likely whip back areas, should the rope break.

Safety Features Of Tirfor

Tirfor style winches have three safety features incorporated in their design:

- The clutch lever cannot be engaged whilst the machine is under load.
- If the strain on the lifting lever becomes too much for one rescuer, it can be assumed that the machine has reached its safe working load.
- If the safe working limit of the machine is exceeded, there are three shear pins in the shaft of the pulling lever. If rope and machine are in good condition, these pins will fail before more serious damage can occur. Spare shear pins should be carried in the hollow handle of the machine. No special tools are required for replacement. The new pins are inserted, the load immediately eased, and blocks added to the system for greater advantage.

THE RATCHET WINCH

This low cost, readily available, hand operated winch, is a useful tool for rescue, but should not be viewed as a replacement for the Tirfor style winch.

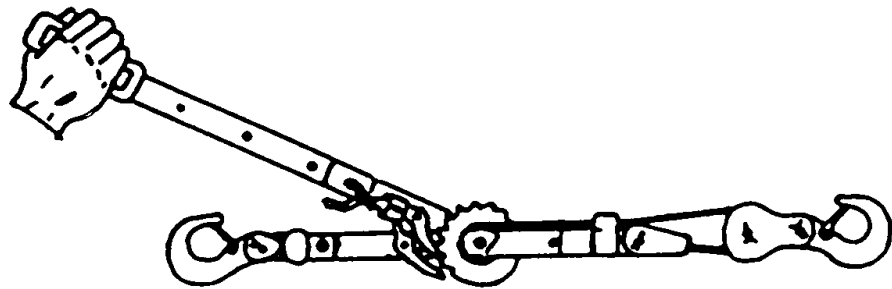

The winch has a handle that cranks a drum via a pawl and ratchet system, thus winding the wire onto the drum. Forward and reverse are achieved by a spring-loaded control of the pawl. The wire rope length and the winch capacity will vary from model to model and must be confirmed prior to use.

WARNING NOTE:

Some cheap ratchet winches are of very poor quality and capability.

A careful check should be made prior to use, and the manufacturer's guidelines must be followed closely.

VEHICLE-MOUNTED POWER WINCHES

WARNING NOTE:

Never use vehicle mounted power winches to retrieve casualties.

The human body pulls apart often before the winch is overloaded.

Power winches are available in many types and variations, and each has its own particular characteristics and attributes. In all cases, the manufacturers instructions must be read carefully prior to use.

Precautions In Operations

- Always be aware of the manufacturer's specifications and safe working loads and operate the winch within those parameters.
- Do not step over or stand near a winch rope while under tension, the back lash from a broken cable can be fatal.
- Do not hook the winch rope back over itself, as this reduces the Safe Working Load by up to 50 percent and damages the rope. Use an approved chain, wire or synthetic fibre sling.
- Wear gloves at all times when handling the cable. Frayed cable can inflict serious wounds.
- Do not handle the cable closer than 750mm from the drum when winching in. A loose wire may snag the glove and draw the rescuer's hand into the winch.
- Do not winch with less than five turns of cable around the drum.
- Do not use the winch for lifting casualties.
- Replace damaged wire ropes immediately.
- Most winches have a shear pin, which is designed to shear if the winch is overloaded. The shear pin should only be replaced with a genuine replacement pin.
- When winching, always pull in as straight a line as possible.
- Before applying a load to a new wire rope, it should be run out to the last five wraps on the drum and spooled on to the winch under a load.

- Always take out slack in the rope before applying full power to the winch. Sudden jerks may exceed safe working loads.
- With a Power Take Off (PTO) winch, do not release the vehicle clutch rapidly, it could shear the safety pin.
- Do not slip the vehicle clutch.
- Always wind the cable tightly. A good method for winding the cable, is to extend it fully, attach it to a holdfast, and then pull the vehicle with the brakes slightly applied. Wind the entire cable with this load.

The Power Take Off Winch (Mechanical Spool)

The PTO mechanical winch is operated from the power take off, attached to the gear box through a shaft, to the winch mounted on the front bumper bar of the vehicle. Winch speed is controlled by varying the engine speed.

The Power Take Off Winch (Mechanical Capstan)

This winch is mechanically the same to operate as the PTO spool winch, but differs in the 'spooling' method. The capstan is a tapered, vertically positioned drum around which a turn or two of the winch rope is taken. When the operator applies pressure to the running end of the rope, the turning capstan causes the rope to be recovered and thus winching occurs.

The Electrically Powered Spool Winch

The electric winch is one which the spool or drum is driven by an electric motor, similar to a vehicle starter motor, through a gear train. The electric motor is connected by heavy duty cables directly to the vehicle battery.

In most modern winches, a remote control switch to operate all winch functions is supplied and is on a lead long enough to reach back to the drivers seat or to a safe position clear of the cable and the load. A simple 'push-pull' clutch is fitted, so that the drum can free spool to permit faster run out of the winch rope by hand to the hook up point.

Although the winch will operate without the engine running, it is inadvisable to do so unless absolutely necessary, due to the load the winch imposes on the battery.

LEVERS

The purpose of all lifting techniques is to gain sufficient power to lift or hold a large load with a small, suitable applied force.

The simplest appliance for gaining this power is the lever.

There are two principle ways in which a lever can be used.

In each case, the advantage gained depends on the distance of A (the centre of the load), and C, (the point where the force is applied), from B, (the fulcrum).

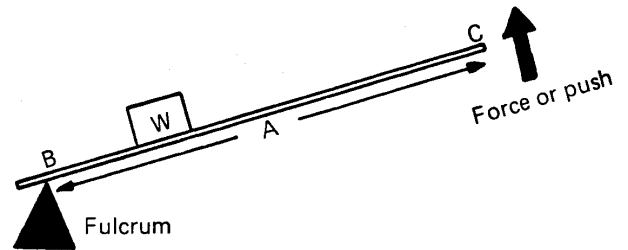

Fulcrum Blocks

A fulcrum should be of hardwood, never of brick or other crushable material. It must be resting on a firm base, which should be as large as practicable so as to distribute the weight to be lifted. The fulcrum must be placed as near to the weight as possible under the circumstances, and it should not be placed at any point where there is a possibility of a casualty being buried immediately below. An appreciation must be made before using the lever to ensure the equipment is strong enough, as a collapse would, of course, be disastrous to a casualty.

Lifting

Power should be applied as near to the end of the lever as practicable. When more than one lever is used, the load should be lifted evenly.

HYDRAULIC RESCUE EQUIPMENT

WARNING NOTE:

Hydraulic rescue equipment should only be used by appropriately trained and qualified personnel.

Hydraulic equipment provides a tremendous mechanical advantage, which is available in the form of a ram or spreader attachment which can be coupled to a standard type of hydraulic pump. The power per weight of equipment can be readily appreciated by the fact that a very basic pump and ram, weighing approximately 9kg, can lift a load of 10 tonnes or more.

The advantage of using hydraulic equipment is that a comparatively small force can be greatly increased. This is due to the fact that when a force is applied to a fluid, it is transmitted equally and undiminished in all directions throughout the fluid.

Hydraulic tools may be available to rescue teams in either hand-operated or power or air-operated models.

CHAPTER THIRTEEN

LIGHTING, POWER & CUTTING EQUIPMENT

GENERATORS

Numerous brands and types of generators are available commercially, but all are basically similar in construction. They have a frame or case, and for safety reasons are fitted with some form of Earth Leakage Circuit Breaker (ELCB) or Residual Current Device (RCD) and a motor driven alternator to produce 240 volts AC (Alternating Current). The ability of the alternator to deliver current is measured by its power output rating in WATTS. This is a power rating that is also often rated in KILOWATTS (kW), ie:

$$1 \text{ Kilowatt} = 1000 \text{ Watts}$$

ELCB'S and RCD'S

These are commonly used methods to describe the same thing. All portable generators are built to minimise the possibility of electric shock.

For portable single-phase generators, an acceptable safe configuration is either:

- **Option One**

- **Floating (Isolated) Windings, without an ELCB/RCD.**

- With an isolated winding there is no loss of power in the event of a single fault in the generator or in the load. Nor is there any indication of such fault. Accordingly, it is ideal for lighting. A person touching 'live parts' will receive no shock.

- **Option Two**

- **Polarised (Frame Connected) Windings, with an ELCB/RCD**

- With a frame connected winding plus RCD, a single fault on load-side equipment will trip the RCD and cause loss of power. A person touching the 'live parts' will receive a minor shock, but will be protected by the RCD.

Portable ELCBs/RCDs must be tested three (3) monthly as per AS3760. Other devices must be tested twelve (12) monthly. If frequently used in harsh or severe environments they should be tested at three (3) monthly intervals using the procedures set out in AS3760.

POWER OUTPUT OF THE GENERATOR

Rescuers must know how to describe the amount of power that a particular appliance will draw so as not to overload the generator.

- Lights and heating appliances are normally rated in **Watts**.

Therefore when using lights only, it is a simple matter to add the wattage of the number of lights being used and subtract the figure from the generator capacity to calculate the power still available.

Example: 3 banks of lights, each drawing 500 Watts are being used:

TOTAL WATTAGE IS 1500 WATTS

Therefore, if a generator was rated at 2500 WATTS or 2.5kW, it can be seen that there is still 1000 Watts capacity left in the generator.

- Appliances using electric motors (eg: drills, chain saws, refrigerators, fans etc.) often indicate the amount of current drawn from the generator, not the power. This is usually found on a compliance plate on the appliance and is rated **Amps**.

Example: An electric chain saw is rated at 5 Amps, the power it draws from the generator is:

POWER (IN WATTS) = 240 VOLTS x 5 AMPS = 1200 WATTS

It can be seen that this particular chainsaw can be run from a 2500 Watt (2.5 kW) generator, but not from a 1000 Watt (1.0kW) generator.

- Rescue teams should calculate the **power** rating of each appliance likely to be used and clearly mark this figure in **Watts** on the appliance to save time and possible overload problems during an emergency.

WARNING NOTE:

Motor starting current is approximately five times the rated full load current of electric motors. When selecting generators for motor starting, this factor should be considered to avoid overloads.

PRECAUTIONS IN OPERATIONS

Any combination of heat, petrol, and electricity, creates a potentially dangerous situation.

The following list of precautions should be observed when operating any generator.

- Do not place combustible material on or near the generator.
- Operate the generator on a stable, level surface to prevent fuel spillage, excessive vibration, and oil starvation.
- During use, keep the generator at least 1 metre away from buildings and other equipment.
- Avoid placing anything around the generator, or covering it up. Generators are normally air-cooled and require a free flow of air to prevent overheating.
- Always stop the engine before refuelling.
- Be careful not to spill fuel on the generator. If fuel is spilt, wipe the machine dry before starting the engine.
- Do not fill the fuel tank above the designated level.
- Do not smoke when refuelling, or expose the process to naked flame.
- Keep a suitable fire extinguisher nearby and upwind of the generator at all times.
- Do not operate the generator in or near locations with poor ventilation such as tunnels, under houses, inside tents, etc. Carbon Monoxide poisoning can rapidly result from a build up of exhaust gases.

ELECTRICAL SAFETY PRECAUTIONS

The electrical output of a generator is lethal. The following safety points should be observed:

- Keep the generator dry. Exercise great care when operating in wet conditions.
- Never connect a generator to a household system.
- Coiled leads should be completely unwound before use.
- On-the-job surveillance of all electrical equipment, particularly leads, continues to be the rule. Checks must be made when stowing or withdrawing equipment from storage.
- Multiple outlets on floating generators are permitted if all equipment is double insulated or 'equipotential' bound.
- All inspection and testing of electrical equipment shall be carried out by a licensed electrician and in accordance with AS3760.
- All electrical equipment, including generators, leads, and fittings should be tested by a licensed electrician within each twelve (12) month period. The equipment mentioned must be tagged to indicate the date of inspection and name of the person inspecting.

GENERATOR MAINTENANCE & OPERATIONAL CHECKS

Before operating any generator, read the manufacturers instruction and:

- Check sump oil level
- Ensure the correct fuel is used
- Use correct starting procedures.
- Generators must be properly maintained to the manufacturers specifications if reliable and long service is to be expected.
- Generators should be run regularly under load.

GENERATOR STORAGE

Many generators used by emergency services have periods where they may not be used for some considerable time.

If this is the case:

- Store the generator with the piston in the compression stroke, thus closing both the inlet and exhaust valves and also closing the breaker points.
 - This procedure prevents corrosion of the combustion chamber, corrosion of the contact points and prevents the valves from sticking open when next the generator needs to be started. The compression stroke can be found by pulling the starter cord or turning the starter pulley until it becomes hard to turn (the piston is rising on the compression stroke), then continuing to turn the pulley until just before the top of the piston stroke.
- Drain the fuel from both the tank and the carburettor.
 - Fuel left for long periods in the carburettor can cause a chemical reaction that adversely affects carburettor components.

LIGHTING

Working at night can increase the dangers involved with rescue work due to shadows, glare, and poor vision associated with artificial lighting systems. Rescuers should experience night rescue situations in training and experiment with various lighting arrangements, so as to eliminate as much as possible the three hazards mentioned.

Positioning Lighting

Little in the way of guidance can be given when lighting the rescue scene because all scenes vary greatly, but the following points are valid for most situations:

- Position lights as high as possible to illuminate the area required.
- If working at heights, do not shine lights from below to illuminate the situation. For example, rescuers on roof tops can suffer a temporary and unsafe loss of night vision by looking down into lights.
- If lights cannot be positioned above the scene, use hand lights or helmet mounted lights only, controlled by the rescuers working at that height.
- A rescuer who is temporary blinded or suffering a loss of night vision for any reason, should stay still and not move until night vision returns.
- A rescue scene is better illuminated with a soft, medium density light for movement within the area, with the particular work scene being illuminated with higher intensity lights such as spotlights.
- Position lights so that large shadows are minimised.
- Keep lighting leads away from any dangerous area where damage is likely to occur.

HAND TOOLS FOR CUTTING

Bolt Cutters

Bolt cutters come in a variety of sizes and styles, but most are capable of cutting through 8mm mild steel. This makes the tool valuable for debris clearance, in reinforced concrete and the removal of padlocks and security grills in areas where it is suspected casualties may be.

Hacksaw

A hacksaw can be used in many situations. Always cut at right angles to the job. Use a wedge to alleviate pressure on the blade. Cut as close as possible to a supported section of the metal.

Cutting may be assisted by using a solution of 6:1 water/detergent to lubricate hacksaw cuts.

Axe

An axe can be used to cut timber or sheet metal. When used to cut sheet metal as an improvised measure, the axe should be driven into the sheet so that the blade penetrates to approximately half the depth of the cutting surface. The handle should be pulled upwards so that the head is almost parallel with the metal. A second rescuer should drive the axe head down with a sledgehammer while the first guides it with the handle.

Handsaws

Other types of handsaws such as the bow saw, general purpose saw, rip saw, etc. all have a part to play in the rescue tool kit and should not be neglected. Remember to train with hand tools, because in a disaster they may be all that you will have.

CHAPTER FOURTEEN

FIRES AND ELEMENTARY FIRE FIGHTING

RESPONSIBILITY FOR FIRE FIGHTING

In rescue situations involving fire, it is the responsibility of the Fire Service to extinguish the fire.

Rescuers would not normally commence operations until advised by the Fire Service that it is safe. On occasions rescuers will be the first to arrive at the incident involving fire, or may be required to protect rescue equipment such as generators. Therefore a basic knowledge of fire, fire fighting techniques, and equipment is required by rescuers.

THE CHEMISTRY OF FIRE

Definition

Fire is a chemical reaction in which heat, smoke, and sometimes light are produced.

Chemistry

For fire to occur, the three necessary elements are:

1. Heat
2. Oxygen, and
3. Fuel

These three elements form the Triangle of Fire.

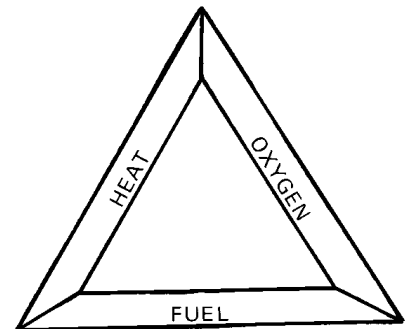

Fire will continue as long as the three elements are present. Elimination or removal of any one of them causes the triangle to collapse, therefore extinguishing the fire. This is the basis of all fire fighting operations.

THE CHEMISTRY OF FIRE EXTINCTION

The principals of fire extinction consist of the elimination or limitation of one, or more of the three elements:

1. Cooling, or the reduction of temperature
2. Smothering, or the limitation of oxygen
3. Starvation, or the elimination of fuel.

Cooling

The most commonly used fire-fighting medium is water. Water cools the heat being produced in the fire to below ignition temperature.

Smothering

By excluding the oxygen in the surrounding atmosphere, the fire will be extinguished. Smothering can be achieved by using sand, blanketing, foam application, or by the use of chemical extinguishers.

Starvation

Starvation is achieved by removal of the fuel burning in the fire. Any combustible material can be removed, or gas or fuel flows shut off.

Specific methods of extinguishing fires often involve a combination of more than one of the three principles.

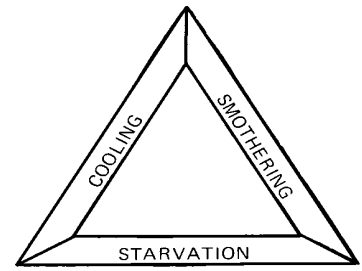

CLASSES OF FIRE

Fires are classified according to the nature of the fuel involved. There are currently six classes of fire as shown in the following table.

CLASS A	Combustible solids	Carbonaceous solids such as wood, paper, plastics, and clothing.
CLASS B	Flammable and combustible liquids	Petroleum based liquids such as petrol, oil, alcohol, and thinners.
CLASS C	Flammable gases	Gases in either vapour or liquefied form such as propane, butane, methane, or acetylene
CLASS D	Combustible metals Fires of this type require special extinguishers and expert advice	Metals such as magnesium, sodium, potassium, or aluminium powder.
CLASS E	Electrical Fires	Fires that involve energised or 'live' electrical equipment or services.
CLASS F	Cooking oils and fats	Grease, fats and cooking oils.

STANDARD FIRE EXTINGUISHER OPERATING PROCEDURES:

The following procedure is in line with current practice:

P	Pull the pin
T	Test the extinguisher is going to operate
A	Aim at the base of the fire
S	Squeeze the operating trigger
S	Sweep the flames off the fuel.

FIRE HOSE REELS

Hose reels can be operated by a single rescuer. The basic procedure is:

- Ensure that the nozzle or jet is in the closed position.
- Turn on the main valve (most reels have a device that only charges the nozzle when the valve is opened).
- Pull the hose off the drum, towards the fire.
- Open the nozzle or valve, and direct the stream of water at the base of the fire.

ACTION TO BE TAKEN BY A PERSON DISCOVERING A FIRE

The following standard procedure is recommended:

- Assess the situation
- Raise the alarm
- Evacuate the immediate area
- Call the Fire Service
- Attack the fire – only if safe to do so
- Always work in pairs.

WORKING AND MOVING IN SMOKE

Working in smoke is extremely dangerous and should be avoided. Rescuers working under these conditions should wear self-contained breathing apparatus, and should be protected by safety lines.

Under emergency conditions, rescuers may have to enter a smoke-affected area to conduct a rescue or to leave the site. On these occasions, rescuers must keep close to the floor, work in pairs, and be monitored by rescuers outside in the clear air.

Refer also to Chapter 2, Moving in an unknown environment, for further information that may be relevant.

CHAPTER FIFTEEN

RESCUE TEAM EQUIPMENT

PERSONAL EQUIPMENT

All rescue personnel must be equipped with the following protective equipment as a minimum requirement:

Personal Equipment

- Overalls With some form of identification showing the organisation to which the person belongs.
- Safety Helmet Complete with chinstrap. Colour to be uniform within team.
- Footwear Leather safety boots or shoes with non-slip soles.
- Debris Gloves Palm to be leather.
- Goggles To give good all round protection from dust and debris.
- Personal Safety Line Minimum length of 4 metres of at least 8 mm line.
- Torch (or Helmet Lamp) With spare batteries & bulbs.
- First Aid Personal First Aid kit (1 x Triangular & 2 x Field Dressings, 4 pr x Surgical Gloves).

Helmet Markings

- Team Leader 2 red bands (reflective) around the helmet.
- Deputy Team Leader 1 red band (reflective) around the helmet.
- All Team Members An option would be to have 1 reflective band around the helmet, as well as the Civil Defence logo and the member's name.

Optional Identification, etc.

- Reflective Jerkin An option to other means of identification.
- Other badges, logos, etc. Should be kept to a minimum to avoid confusion for team members, and to assist recognition from all angles.

The team member is responsible for all equipment issued to them, and should report damage immediately.

RESCUE TEAM EQUIPMENT LIST (SUGGESTED ONLY)

The following list is a guide to the minimum equipment necessary to equip a 6 – 8 person basic rescue team (extra to personal equipment listed previously):

	Item	Quantity
Personal Equipment		
Boots	Safety Boots or shoes	8
First Aid / Medical	Surgical Gloves (4 pr per person)	32
	1 x Triangular Bandage,	8
	2 x Field Dressing	16
Gloves	Leather Debris	8
Goggles	Eye protection	10
Helmet	Safety Helmet (suitably marked)	8
Lines	Personal (4+m x 8+mm)	8
Mask	Dust, moulded type	8
Overalls	Heavy Duty Cotton	8
Torch (or Head Lamp)	1 each as applicable	8
Team Equipment		
Blankets	Wool / wool mix, hemmed, standard single size	8
Ladder	Extension (wooden, 4m x 7m)	1
Lines	Lashing (12mm x 12m)	8
Masks	Dust, moulded type	10
Pickets		5
Stretcher	Board Rescue	2
	Basket type (high impact plastic)	1
	Furley / NATO / Field type	2
Tools	Crowbar	1
	Wood saw (general purpose)	1
	Hacksaw with spare blades	1
	Sledgehammer (3.5 kg)	1
Torch (or Head Lamp)	Spares	2

APPENDIX

Index of Photographs on CD-ROM and Website

Chapter 1	nil
Chapter 2	Stair Climb
Chapter 3	nil
Chapter 4	Bight of a Rope Chair Knot (5) Vertical Lift Knot (7)
Chapter 5	Alpine Butterfly (8) Double Figure 8 on a Bight (4) Double Fisherman's Knot (8) Figure 8 Joining Knot (4) Figure 8 on a Bight (2) Friction Hitch (4) Kernmantel Rope (2) Prusik Knot (5) Rethreaded Figure 8 (5) Round Turn & 2 Half-Hitches (4) Tape Knot (5) Thumb Knot
Chapter 6	Thumb Knot Timber Hitch (5)
Chapter 7	3,2,1 Picket Autolock Descenders Karabiners Friction Devices Mallion Pulleys Racks Stretcher Karabiner
Chapter 8	Ladder Angle Check Ladder Climbing Ladder Leg Lock Ladder Picketing

	Ladder Raise 3 Rescuers (3)
	Ladder Step Off
	Ladder Tie Off – Top
Chapter 9	4 Person Lift (3)
	Blanket Lift (2)
	Board Lashing (2)
	Board Lowering Line
	Clothing Lift
	Four Person Lift
	NATO stretchers (5)
Chapter 10	1 Person Walk
	2 Person Assisted Walk
	3 Handed Seat
	4 Handed Seat
	Firemans Crawl
	Fore and Aft Carry (2)
	Improvised Ladder Stretcher
	Improvised Chair Lift
	Pack Strap-Piggy Back
	Pack Strap Carry
	Stair Carry
Chapter 11	2 Point Lower
	4 Point Lower (5)
	Basket Stretcher (4)
	Ladder Hinge (5)
	Ladder Slide (3)
Chapter 12	nil
Chapter 13	nil
Chapter 14	nil
Chapter 15	nil