



A TEREX BRAND

# *Parts Manual*

Serial Number Range

**GS-2046**

to SN 59999

**GS-2646**

**GS-3246**

Part No. 48338

Rev G4

April 2017

---

## Technical Publications

Genie has endeavored to deliver the highest degree of accuracy possible. However, continuous improvement of our products is a Genie policy. Therefore, product specifications are subject to change without notice.

Readers are encouraged to notify Genie of errors and send in suggestions for improvement. All communications will be carefully considered for future printings of this and all other manuals.

---

## Contact Us:

Internet: [www.genielift.com](http://www.genielift.com)  
e-mail: [awp.techpub@terex.com](mailto:awp.techpub@terex.com)

---

## Find a Manual for this Model

Go to <http://www.genielift.com>

Use the links to locate Operator's, Parts, Maintenance, and Service and Repair Manuals.

---

Copyright © 2011 by Terex Corporation

48338 Rev F July 2009  
First Edition, Sixth Printing

Genie is a registered trademark of Terex South Dakota, Inc. in the USA and many other countries. "GS" is a trademark of Terex South Dakota, Inc.

 Printed on recycled paper

**Genie**  
A TEREX BRAND

Model: GS-1930  
Serial number: GS3005A-12345  
Model year: 2005    Manufacture date: 04/12/05  
Electrical schematic number: ES0141  
Machine unladen weight: 2,714 lb / 1,231 N

Rated work load (including occupants): 500 lb / 227 kg  
Maximum allowable inclination of the chassis:  
N/A

Gradeability: N/A

Maximum allowable side force : 100 lb / 445 N  
Maximum number of platform occupants:2

Country of manufacture: USA  
This machine complies with:  
ANSI A92.6-  
B354.2-

Terex South Dakota, Inc.  
18340 NE 76th Street  
Redmond, WA 98052  
USA



1 1 0 0 1 1 1 1

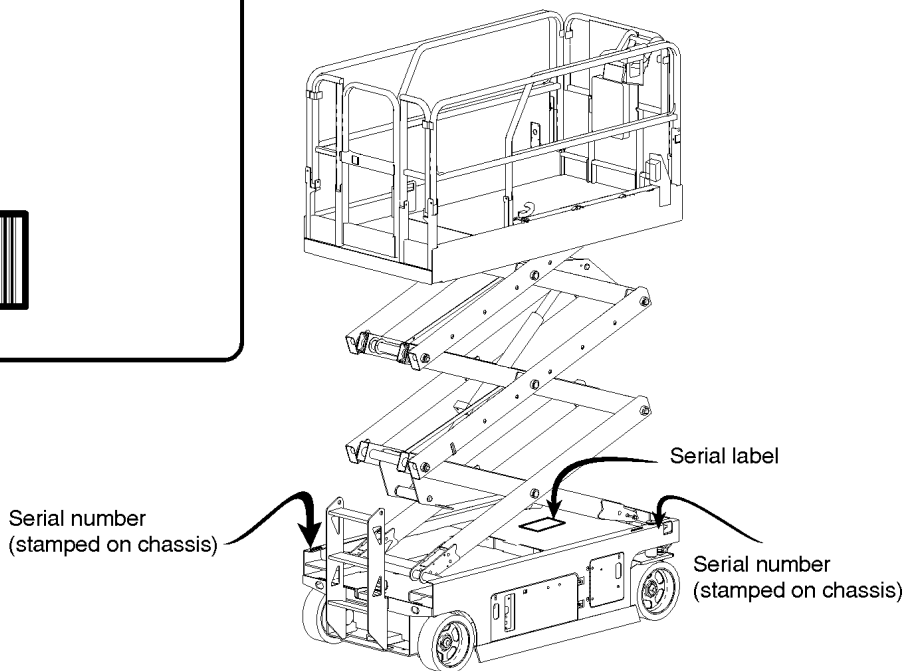
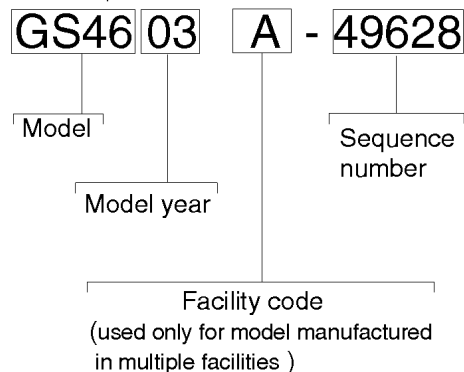

Table of Contents

This manual is updated frequently. If you have a printed manual, you can keep it up to date by downloading new figures from the Genie website at [www.genielift.com](http://www.genielift.com). For the most up-to-date parts information, visit the Parts Lookup System on the Genie website at [www.genielift.com](http://www.genielift.com).

How to Read Your Serial Number.....3  
 Parts Stocking List.....7  
 How to Order Parts.....8  
 Service Parts Fax Order Form.....9

**Electronic Version**

Click on any page number to view the figure.

**100 Decals**  
 101.1 Decals.....10  
 102.1 Platform Control Box Decals.....14

**200 Drive Chassis Components**  
 201.1 Steer Axle Linkage and Wheels (to SN 43634).....16  
 201.2 Steer Axle Linkage and Wheels (from SN 43635).....18  
 202.1 Ground Controls and Level Sensor Installation (to SN 1999).....20  
 202.2 Ground Controls and Level Sensor Installation (from SN 2000).....22  
 203.1 Battery Charger.....24  
 203.2 Battery Charger, 110V AC, Asia.....26  
 203.3 Battery Charger, 220V AC, European.....28  
 203.4 Battery Charger - Domestic and Worldwide.....30  
 204.1 Battery Pack Module Tray Installation (to SN 36044).....32  
 204.2 Battery Pack Module Tray Installation (from SN 36045).....34  
 205.1 Battery Pack Module (to SN 35799).....36  
 205.2 Battery Pack Module (from SN 35800).....38  
 206.1 Non-steer Axle and Brake Release Hand Pump Installation.....40  
 207.1 Pothole Protection Assembly and Counterweights (to SN 35799).....42  
 207.2 Pothole Protection Assembly and Counterweights (from SN 35800).....44  
 208.1 Power Unit Module Installation (to SN 35799).....46  
 208.2 Power Unit Module Installation (from SN 35800).....48  
 209.1 Power Unit Module Tray (to SN 36044).....50  
 209.2 Power Unit Module Tray (from SN 36045).....54  
 210.1 Hydraulic Power Unit.....56

211.1 Function Manifold (to SN 36044).....58  
 211.2 Function Manifold (from 36045).....60  
 211.3 Function Manifold - Models with Traction Control.....62  
 212.1 Ground Controls (to SN 28695).....64  
 212.2 Ground Controls (from SN 28696).....66  
 213.1 Hydraulic Hoses and Fittings (to SN 36044).....68  
 213.2 Hydraulic Hoses and Fittings (from 36045).....70  
 214.1 Power Cables - Drive Chassis (to SN 6899).....74  
 214.2 Power Cables - Drive Chassis (from SN 6900).....76

**300 Scissor Components**

301.1 Scissor Assembly, GS-2046, View 1 (to SN 23567)...78  
 301.2 Scissor Assembly, GS-2046, View 1 (from SN 23568).....80  
 302.1 Scissor Assembly, GS-2046, View 2 (to SN 23567)...82  
 302.2 Scissor Assembly, GS-2046, View 2 (from SN 23568).....84  
 303.1 Scissor Assembly, GS-2646, View 1 (to SN 23567)...86  
 303.2 Scissor Assembly, GS-2646, View 1 (from SN 23568).....88  
 304.1 Scissor Assembly, GS-2646, View 2 (to SN 23567)...90  
 304.2 Scissor Assembly, GS-2646, View 2 (from SN 23568).....92  
 305.1 Scissor Assembly, GS-3246, View 1 (to SN 23567)...94  
 305.2 Scissor Assembly, GS-3246, View 1 (from SN 23568).....96  
 306.1 Scissor Assembly, GS-3246, View 2 (to SN 23567)...98  
 306.2 Scissor Assembly, GS-3246, View 2 (from SN 23568).....100

**400 Platform Components**

401.1 Platform Installation.....102  
 402.1 Platform Railings and Entry Gate - Rigid Rails (to SN 42999).....104  
 402.2 Platform Railings and Entry Gate - Fold Down Rails, Round Tube (to SN 42999).....106  
 402.3 Platform Railings and Entry Gate - Fold Down Rails, Square Tube (from SN 23568).....108  
 403.1 Platform Extension - Rigid Rails.....110  
 403.2 Platform Extension - Fold Down Rails, Round Tube.112  
 403.3 Platform Extension - Fold Down Rails, Square Tube.114  
 404.1 Power to Platform - Rigid Rails.....116  
 404.2 Power to Platform - Fold Down Rails.....118  
 405.1 Control Cable - Chassis to Platform.....120  
 406.1 Platform Controls (to SN 17407).....122  
 406.2 Platform Controls (from SN 17408 to 42999).....124  
 406.3 Platform Controls (from SN 43000 to 48054).....126  
 406.4 Platform Controls (from SN 48055).....128  
 407.1 Joystick Controller (to SN 17407).....130

407.2 Joystick Controller (from SN 17408 to 48054).....132  
407.3 Joystick Controller (from SN 48055).....134

**500 Accessories**

501.1 Alarms - Horn and Flashing Beacon.....136  
502.1 Air Line to Platform.....138  
503.1 Platform Worklight.....140  
504.1 Platform Overload Protection.....142  
505.1 Voltage Inverter.....144  
506.1 Battery - Maintenance Free.....146  
507.1 Pipe Cradle Assembly.....148

**Indices**

Part Number Index.....150  
Part Description Index.....154

**Cross References**

Fittings Cross Reference.....160



### Required Parts

The following parts are required to perform maintenance procedures as outlined in the *Genie GS-46 Service Manual*.

Description	Part No.
Filter Element, 10 Micron.....	44788
Dielectric Grease.....	66399
Chevron Ultra-duty Grease (Lithium) or equivalent, EP NLGI 1.....(source locally)	
Breather Cap, Hydraulic Tank.....	78546
Cotter Pin, Castle Nut, Steer-end Wheels, GS-32, GS-46.....	13635-10
Cotter Pin, Castle Nut, Steer-end Wheels, GS-30 and Non-steer end Wheels, All Models .....	42079

### Recommended Parts

Description	Part No.
Genie Blue Paint, 1 Gallon .....	32150
Genie Blue Paint, 12 Ounce Aerosol.....	1484
Genie Gray Paint, 1 Gallon .....	32151
Genie Gray Paint, 12 Ounce Aerosol .....	1268

Genie also offers the following support documents:

EMI Safety Manual .....	27581
Manual of Responsibilities ANSI A92.5 .....	44163

## How to Order Parts

Please be prepared with the following information when ordering replacement parts for your Terex or Genie product.

- Machine model number
- Machine serial number
- Part number
- Part description and quantity
- Purchase order number
- "Ship to" address
- Desired method of shipment
- Name and telephone number of the authorized distributor in your area

Use the Service Parts Fax Order Form on the next page and fax your order to our Parts Department.

If you don't know the name of your authorized distributor, or if your area is not currently serviced by an authorized distributor, please call Terex or Genie Industries.

### Machine Information

\_\_\_\_\_

Model

\_\_\_\_\_

Serial Number

\_\_\_\_\_

Date of Purchase

\_\_\_\_\_

Authorized Genie Distributor

\_\_\_\_\_

Phone Number

#### North America

Telephone (425)881-1800

Toll Free (800)536-1800 in US and Canada

Fax (425)556-8659

Toll Free fax (888)274-6192

Email [AWP.PartsSalesPO@terex.com](mailto:AWP.PartsSalesPO@terex.com)

<http://genielift.com/en>

#### EMEAR (Europe, Middle East, Africa and Russia)

Telephone (31)(165)519 313

Fax (31)(165)511 148

<http://genielift.co.uk>

#### Asia Pacific (Genie Singapore)

Telephone +65 6692 7777

Fax +65 6261 8893

<http://genielift.com.sg/>

#### Australia

Telephone (61)(7)3456 4444

Fax (61)(7)3456 4466

<http://genielift.com.au>

#### South America

Telephone (55)(11)4082 5600

Fax (55)(11)4082 5630





101.1 Decals

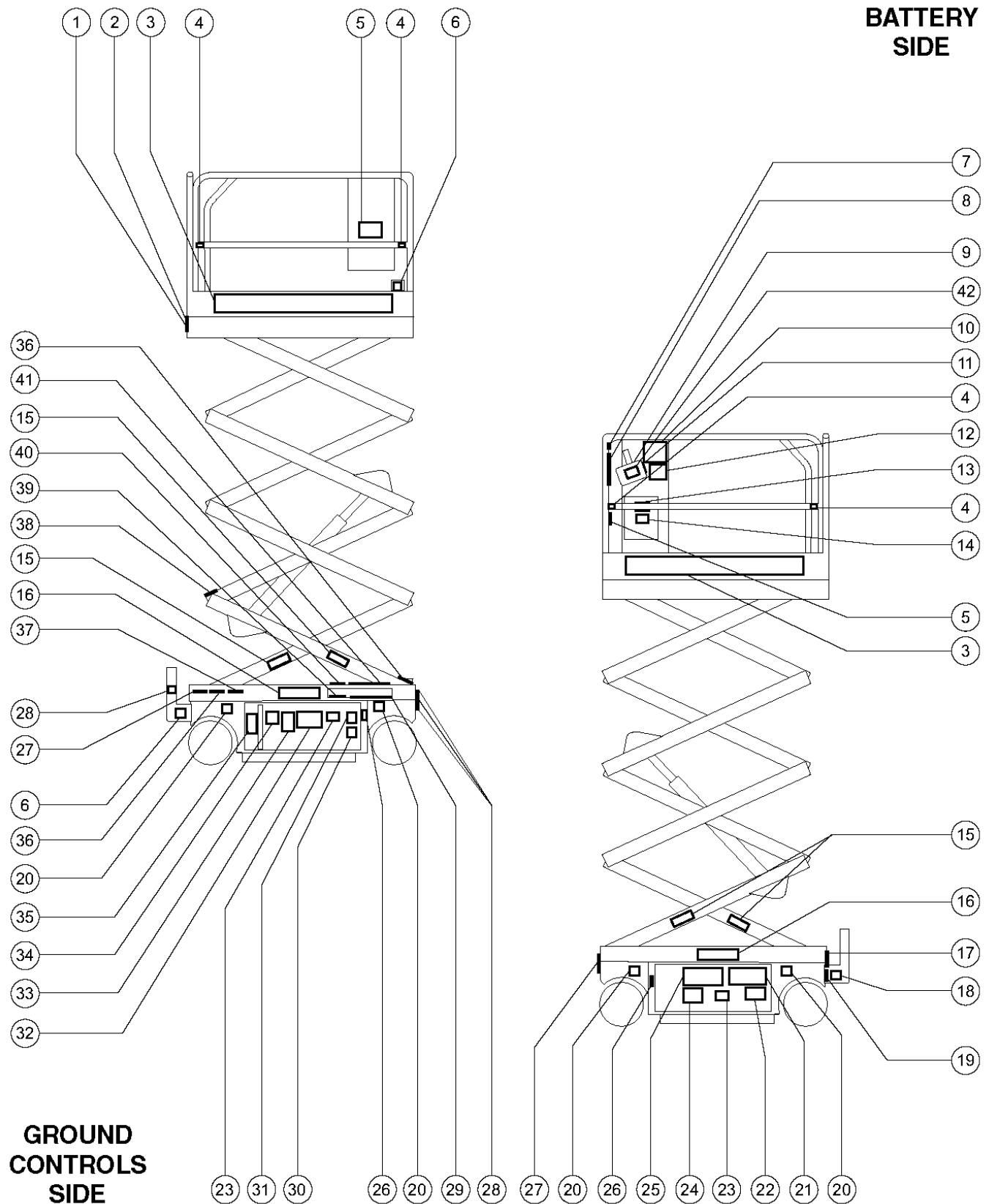

101.1 Decals

Item	Part No.	Description	Qty.	Item	Part No.	Description	Qty.
--	46328GT	DECAL KIT-SFTY/INST,2032,2646 <i>(does not include Index numbers 1-4, 6, 7, 9, 18, 26, 28, 30, 37 and 40)</i>		6	28235GT	DECAL,POWER TO PLATFORM 115V...2	
1	52084GT	DECAL,NOTICE,MAX CAP 1200/250.....1 <i>GS-2046 (ANSI, CSA, CE and Australia) (544 kg)</i>		7	52494GT	DECAL,CAUTION,CRUSH HAZ, RAILS.....1	
1A	48331GT	DECAL,NOTICE,MAX CAP 1000/250*.....1 <i>GS-2646 (ANSI, CSA, and CE) (454 kg)</i>		8	43091GT	DECAL,DANGER,GENERAL SAFETY....1	
--	78027GT	DECAL,NOTICE,MAX CAP,2646 AU.....1 <i>(1000 lbs, 454 kg)</i>		9		Ref. Platform Control Panel.....1 <i>(refer to Figure 102.1)</i>	
1B	52337GT	DECAL,NOTICE,MAX CAP 700 ANSI.....1 <i>(GS-3246) (to SN 24438) (700 lbs, 318 kg)</i>		10	43090GT	DECAL,NOTICE, OPER INST, PCP.....1	
--	44254GT	DECAL,NOTICE,MAX CAP 500 ANSI*.....1 <i>GS-3246 (CSA) (to SN 24438) (500 lbs, 227 kg)</i>		11	46238GT	DECAL,NOTICE,ERROR LIGHT.....1	
--	78028GT	DECAL,NOTICE,MAXCAP,3246 AU/CE.....1 <i>(from SN 24440) (700 lbs, 318 kg)</i>		12	44736GT	DECAL,DANGER,TIP-OVER,TILT.....1	
2	52609GT	DECAL,NOTICE,SIDE FRC,2046ANSI...1 <i>(ANSI, CSA) (180 lbs, 801 N)</i>		13	28236GT	DECAL,WARN,IMPROPER OPERATION.....1	
--	52561GT	DECAL,NOTICE,SIDE FRC,2046AUS.....1 <i>(CE, AU) (indoor: 180 lbs, 801 N, wind speed: 0 mph, 0 m/sec) (outdoor: 90 lbs, 400N; wind speed: 28 mph, 12.5m/sec)</i>		14	28176GT	DECAL,LABEL,MANUAL NOT HERE.....1 <i>(located inside manual storage box)</i>	
2A	52610GT	DECAL,NOTICE,SIDE FRC,2646ANSI...1 <i>(ANSI, CSA) (150 lbs, 667 N)</i>		15	44255GT	DECAL,DANGER,CRUSHING HAZARD.....4	
--	52562GT	DECAL,NOTICE,SIDE FRC,2646CE.....1 <i>(indoor: 150 lbs, 667 N, wind speed: 0 mph, 0 m/sec) (outdoor: 90 lbs, 400N; wind speed: 28 mph, 12.5m/sec)</i>		16	43696GT	DECAL,DANGER,ELEC HAZARD,GS....2	
--	78026GT	DECAL,NOTICE,SIDE FRC,2646 AU.....1 <i>(indoor: 150 lbs, 667 N, wind speed: 0 mph, 0 m/sec) (outdoor: 45 lbs, 200N; wind speed: 28 mph, 12.5m/sec)</i>		17	44220GT	DECAL,DANGER,BRAKE REL SAFETY*.....1	
2B	72120GT	DECAL,NOTICE,SIDE FRC,3246ANSI...1 <i>(ANSI, CSA) (105 lbs, 467N)</i>		18	44980GT	DECAL,LABEL,PWR TO CHARGR 115 UK.....1	
--	52563GT	DECAL,NOTICE,SIDE FRC,3246CE.....1 <i>(indoor: 105 lbs, 467 N, wind speed: 0 mph, 0 m/sec) (outdoor: 45 lbs, 200N; wind speed: 28 mph, 12.5m/sec)</i>		18A	43658GT	DECAL,LABEL,PWR TO CHARGR 230V.....1	
--	72084GT	DECAL,NOTICE,SIDE FRC,3246AUS.....1 <i>(indoor: 105 lbs, 467 N, wind speed: 0 mph, 0 m/sec) (outdoor: 45 lbs, 200N; wind speed: 28 mph, 12.5m/sec)</i>		19	31508GT	DECAL,DANGER,ELECT HAZARD,PLUG.....1	
3	62056GT	DECAL,COSMETIC,GENIE GS-2046**...2		20	46287GT	DECAL,LABEL-TIRE SPECS.....4	
3A	62057GT	DECAL,COSMETIC,GENIE GS-2646.....2		21	31785GT	DECAL,NOTICE,CHARGER INSTRUC...1	
3B	62058GT	DECAL,COSMETIC,GENIE GS-3246.....2		22	46286GT	DECAL,NOTICE,BATTERY CONNECT.....1	
4	40434GT	DECAL,LANYARD ANCHORAGE POINT.....5		23	44737GT	DECAL DANGER TIP OVER TRAYS.....2	
5	43618GT	DECAL, LABEL - DIRECTION ARROWS.....2		24	43617GT	DECAL,DANGER,TIP-OVER,BATTERY..1 <i>(batteries)</i>	
6	28174GT	DECAL,POWER TO PLATFORM 230V...2		25	46262GT	DECAL,DANGER,BATTERY SAFETY.....1	
				26	72833GT	DECAL,LABEL,OPEN,LATCH.....2	
				27	28161GT	DECAL,WARN,CRUSH HAZARD HAND.....2	
				28	52475GT	DECAL,LABEL,TRANSPORT TIEDOWN*.....5	
				29	43094GT	DECAL, GROUND CONTROL PANEL***.....1	
				30	65052GT	DECAL,LABEL,FAULT CODES.....1	
				31	44753GT	DECAL, LABEL, LED READOUT.....1	
				32	28175GT	Warning - Compartment Access.....1	
				33	28164GT	DECAL,NOTICE,HAZARDOUS MAT'LS*.....1	
				34	28171GT	DECAL,DANGER,NO SMOKING ***.....1	
				35	44994GT	DECAL,LABEL,DEXRON/FLUID LEVEL.....1 <i>(to SN 48523)</i>	



101.1 Decals  
(continued)

Item	Part No.	Description	Qty.
35A	82368GT	DECAL,LABEL,RYKON/FLUID LEVEL....1 <i>(from SN 48524)</i>	1
36	31060GT	DECAL,DANGER DO NOT ALTER SWTC.....	2
37	77046GT	SERIAL # LABEL,MYLAR 4X8***.....	1
38	43619GT	DECAL,LABEL,SAFETY ARM.....	1
39	37145GT	DECAL, MANUAL LOWERING VALVE....	1
40	72853GT	DECAL,DANGER,IMPROPER USE HAZ.....	1
41	43089GT	DECAL,INSTRUCTIONS-OPER,GCP.....	1
42	65058GT	DECAL, LABEL, GS32/46.....	1

*This Page Intentionally Left Blank*

102.1 Platform Control Box Decals

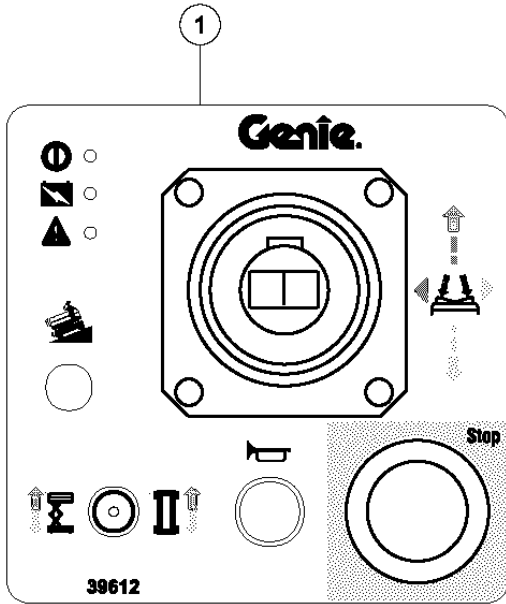

**Gen I**  
Emergency Stop button in lower right corner

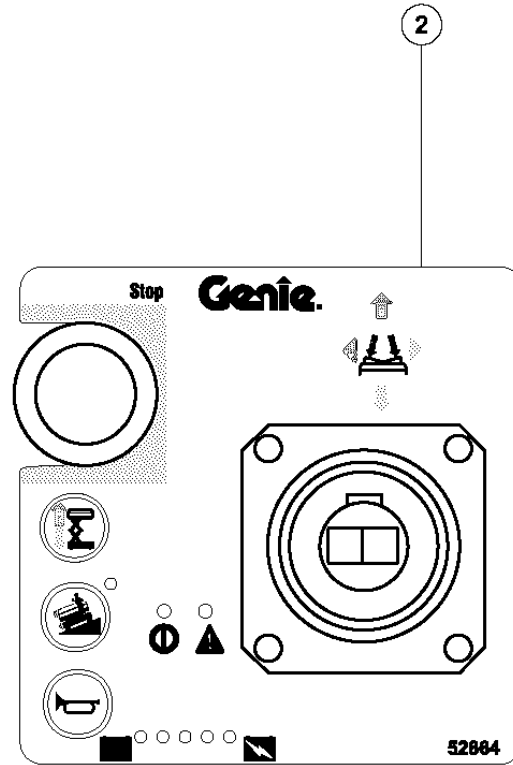

**Gen II**  
One function select button (lift) AND  
Emergency Stop button in upper left corner

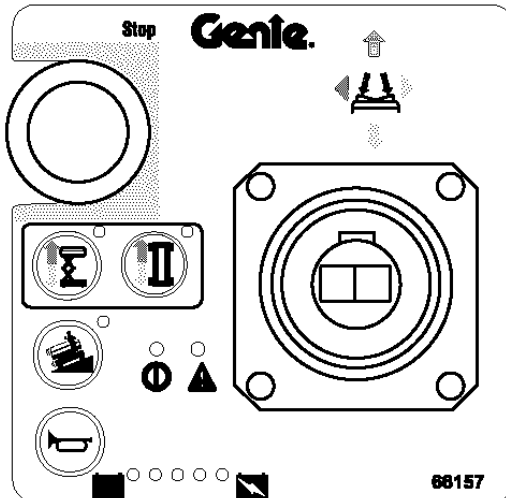

**Gen III**  
Two function select buttons (lift and drive) AND  
Emergency Stop button in upper left corner AND  
joystick secured from outside box

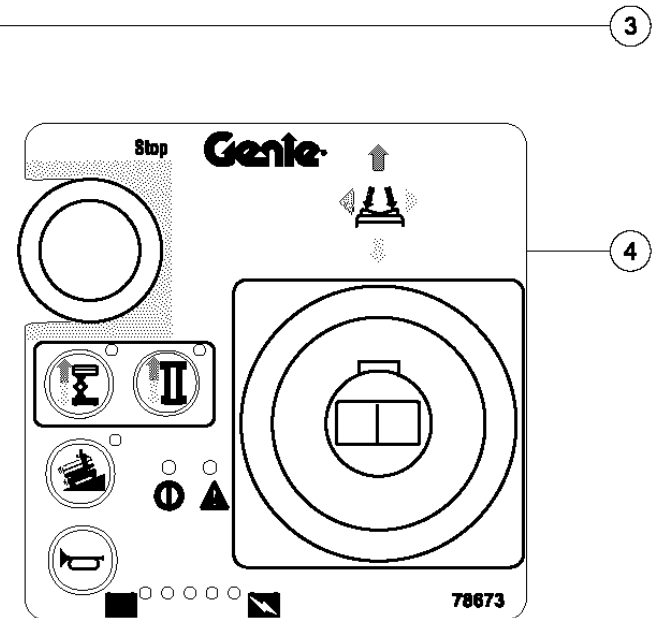

**Gen IV**  
Two function select buttons (lift and drive) AND  
Emergency Stop button in upper left corner AND  
large joystick base secured from inside box

102.1 Platform Control Box Decals

Item	Part No.	Description	Qty.
1	39612GT	DECAL,JOYSTICK**.....1 (Gen I)	1
2	52864GT	DECAL,JOYSTICK CONTROLLER.....1 (Gen II)	1
3	66157GT	OVERLAY,PLAT CONTROLLER SLAB....1 (Gen III)	1
4	78673GT	OVERLAY, PLAT CONTRL BOX,GEN4~.....1 (Gen IV)	1



201.1 Steer Axle Linkage and Wheels (to SN 43634)

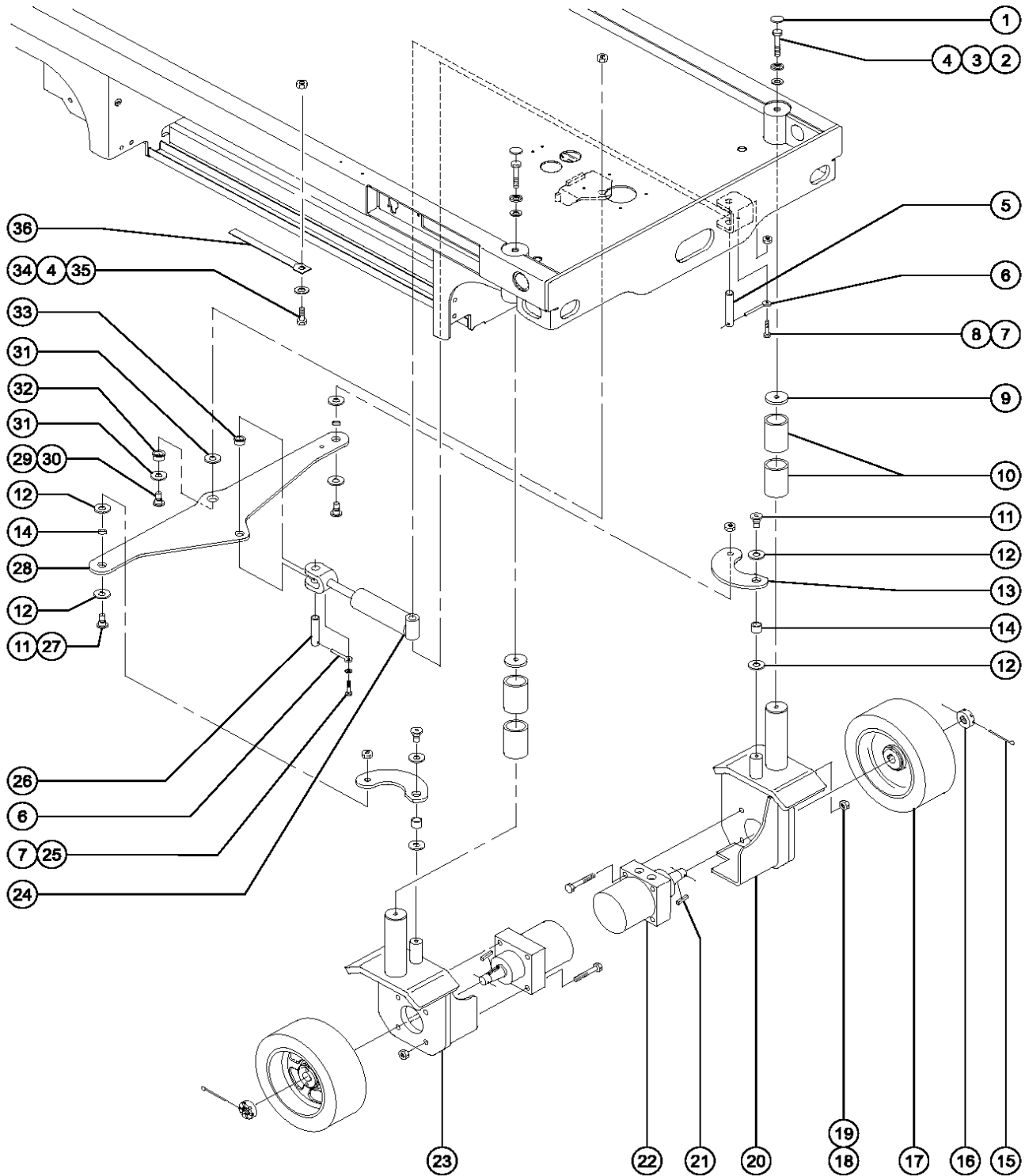



201.1 Steer Axle Linkage and Wheels (to SN 43634)

Item	Part No.	Description	Qty.	Item	Part No.	Description	Qty.
--	78070GT	STEERING,SRV KIT,GS2646/3246 <i>(from SN 1 to 42999) (includes heavy-duty bellcrank and steer links, and all pins and fasteners)</i>		21	44781GT	KEY,RECTANGULAR,.31X.28X1.25***.....2 <i>(0.31 x 0.28 x 1.25 inches)</i>	
1	47189GT	CAP,FINISHING,BLACK.....2		22	78222GT	SRV KIT, DRIVE MOTOR, GS32/46.....2 <i>(to SN 45212) (includes one each 1 items 16 and 21)</i>	
2	6019GT	SCREW,HHC,3/8-16 X 1.25 GRD 5.....2		--	44782GT	SEAL KIT,DR MTR.GS15/19,Z20***.....2 <i>(to SN 45212)</i>	
3	47190GT	WASHER,FINISHING CAP.....2		--	44783GT	BEARING,DRIVE MOTOR GS15/19.....2 <i>(to SN 45212)</i>	
4	6097GT	WASHER,FLAT,USS,3/8",Y.....3		23	55992-SGT	WELDMENT STEERYOKE RH 32/46***.....1 <i>(to SN 42999) (power unit side)</i>	
5	39250GT	PIN,0.75DIA X 4.28LG,CHAMFER.....1 <i>(1.9 x 10.2 cm)</i>		23A	78045GT	WELDMENT,RH STEER YOKE,32/46* <i>(from SN 43000)</i>	
6	45748GT	ROD END,.250 X 2.75 LG.....2		24	39038GT	CYLINDER,STEERING GS15/GS19.....1	
7	6888GT	SCREW,HHC,1/4-20 X 1.....2		--	44250GT	SEAL KIT-FOR P.N.39038(SCISRS).....1	
8	6889GT	NUT,LP NYLOCK,1/4-20.....1		25	6356GT	WASHER, LOCK, .25.....1	
9	39240GT	WASHER,THRUST,.5 X 2.438 X .25.....2		26	39586GT	PIN,.75 DIA X 2.75 LG,CHAMFER.....1	
10	18722GT	BEARING,2.25IDX2.50ODX1.50L*.....4 <i>(5.7 x 6.4 x 3.8 cm)</i>		27	38028GT	NUT,LP NYLOCK,5/8-11.....2	
11A	47255GT	BOLT,SHORT SHOULDER.....2 <i>used on early generation steer yokes (shown)</i>		28	48352GT	BELLCRANK,STEER W/BEARING 2646.....1 <i>(to SN 42999) (includes 2 each item 14 and item 33)</i>	
11B	38028GT	NUT,LP NYLOCK,5/8-11.....2 <i>used on later generation steer yokes</i>		28A	78077GT	SERV,BELLCRANK ASSY, GS46 <i>(from SN 1 to 42999) for use ONLY after installation of 78070 steering service kit, above</i>	
12	47520GT	WASHER,THRUST .75 X 1.25 X .06.....8		28B	78077GT	SERV,BELLCRANK ASSY, GS46.....1 <i>(from SN 43000) (includes 2 each item 14 and items 32 and 33)</i>	
13	46343GT	STEER LINK ASSY W/BRGS.GS2032....2 <i>right and left sides (from SN 1 to 42999) (includes 1 each item 14)</i>		29	47464GT	BOLT, WIDE SHOULDER.....1	
13A	78075GT	SRV KIT,32/46 STR. LINK ASSY,R.....1 <i>right (from SN 1 to 42999) for use ONLY after installation of 78070 steering service kit, above</i>		30	8538GT	NUT,LP NYLOCK,3/4-10.....1	
13A	78076GT	SRV KIT,32/46 STR. LINK ASSY,L.....1 <i>left (from SN 1 to 42999) for use ONLY after installation of 78070 steering service kit, above</i>		31	47521GT	WASHER,THRUST 1 X 1.75 X .058.....2	
13B	78075GT	SRV KIT,32/46 STR. LINK ASSY,R.....1 <i>right (from SN 43000 to 43634)</i>		32	47946GT	BEARING,1.00IDX1.25ODX0.49L.....1 <i>(2.5 x 3.8 x 1 cm)</i>	
13B	78076GT	SRV KIT,32/46 STR. LINK ASSY,L.....1 <i>left (from SN 43000 to 43634)</i>		33	47547GT	BEARING,FL,.75IDX1.25ODX.5 L.....2 <i>(from SN 43000) (1.9 x 3.2 x 1.27 cm)</i>	
14	39581GT	BEARING,0.75IDX1.00ODX0.50L.....2 <i>(from SN 43000) (1.91 x 2.54 x 1.27 cm)</i>		33A	47548GT	BEARING,FL,0.75ID X 1 OD X .49.....1 <i>(to SN 42999) (1.9 x 2.5 x 1 cm)</i>	
14A	39580GT	BEARING,0.75IDX1.00ODX0.38L.....4 <i>(to SN 42999) (1.91 x 2.54 x 0.97 cm)</i>		34	6175GT	SCREW,HHC,3/8-16 X 1.....2	
15	42079GT	PIN,COTTER,.156 X 2.5.....2		35	4828GT	NUT,NYLOCK,3/8-16.....2	
16	44780GT	NUT,CASTLE,1.125-18 UNEF.....2		36	96317GT	GROUND STRAP,12"LG***.....1	
17	105454GT	WHEEL & TIRE ASSY LP,15".....2					
18	6198GT	NUT,NYLOCK,1/2-13.....8					
19	39479GT	SCREW,HHC,1/2-13 X 2.75.....8					
20	55991-SGT	WELDMENT STEERYOKE LH 32/46**...1 <i>(to SN 42999) (battery pack side)</i>					
20A	78044GT	WELDMENT,LH STEER YOKE, 32/46* <i>(from SN 43000)</i>					



201.2 Steer Axle Linkage and Wheels (from SN 43635)

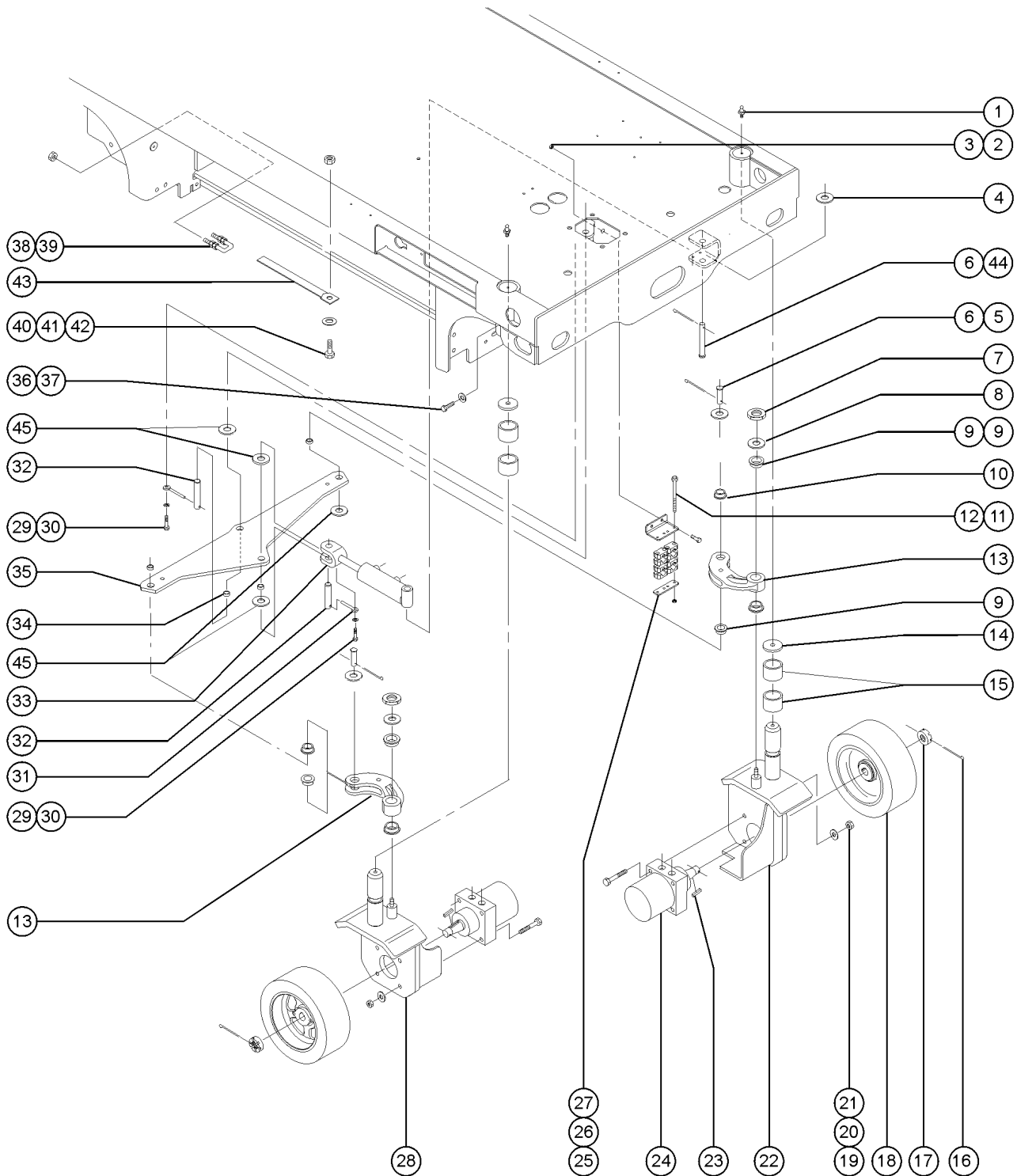

201.2 Steer Axle Linkage and Wheels (from SN 43635)

Item	Part No.	Description	Qty.	Item	Part No.	Description	Qty.
1	55953GT	ZERK-GREASE,1/4-28, STRAIGHT.....	2	27A	96197GT	FORMING,HOSE ROUTING,BULKHEAD.....	1 <i>(from SN 49200)</i>
2	6019GT	SCREW,HHC,3/8-16 X 1.25 GRD 5.....	2	28	78045GT	WELDMENT,RH STEER YOKE,32/46* ....	1 <i>(battery pack module side)</i>
3	4828GT	NUT,NYLOCK,3/8-16.....	2	29	6356GT	WASHER, LOCK, .25.....	2
4	55355GT	SPACER,.75ID X 1.5OD X 1/4THK.....	1	30	6888GT	SCREW,HHC,1/4-20 X 1.....	2
5	6545GT	PIN,CLEVIS,.75 X 2.....	2	31	45748GT	ROD END,.250 X 2.75 LG.....	2
6	13635-10GT	PIN,COTTER,.156 X 1.75.....	3	32	39586GT	PIN,.75 DIA X 2.75 LG,CHAMFER.....	1
7	38028GT	NUT,LP NYLOCK,5/8-11.....	2	33	39038GT	CYLINDER,STEERING GS15/GS19.....	1
8	6035GT	WASHER,FLAT,USS,5/8",Y.....	2	--	44250GT	SEAL KIT-FOR P.N.39038(SCISRS).....	1
9	47946GT	BEARING,1.00IDX1.25ODX0.49L.....	4	34	39581GT	BEARING,0.75IDX1.00ODX0.50L.....	2 <i>(1.91 x 3.18 x 0.97 cm)</i>
10	47548GT	BEARING,FL,0.75ID X 1 OD X .49.....	4	35	78077GT	SERV,BELLCRANK ASSY, GS46.....	1 <i>(includes 2 each item 10 and item 34)</i>
11	6884GT	SCREW,HHC,1/4-20 X 2.5.....	4	36	55917GT	SCREW, YOKE LOCK ALL SLABS.....	4
12	6091GT	NUT,NYLOCK,1/4-20.....	4	37	20912GT	WASHER,LOCK,.437,PLTD.....	4
13	97016GT	STEER LINK ASSY GS46.....	2 <i>(includes 2 each items 9 and 10)</i>	38	66778GT	U-BOLT,SQ BEND, 1/2-13.....	2
14	39240GT	WASHER,THRUST,.5 X 2.438 X .25.....	2	39	6198GT	NUT,NYLOCK,1/2-13.....	2
15	18722GT	BEARING,2.25IDX2.50ODX1.50L*.....	4	40	6175GT	SCREW,HHC,3/8-16 X 1.....	2
16	42079GT	PIN,COTTER,.156 X 2.5.....	2	41	6097GT	WASHER,FLAT,USS,3/8",Y.....	2
17	44780GT	NUT,CASTLE,1.125-18 UNEF.....	2	42	4828GT	NUT,NYLOCK,3/8-16.....	2
18	105454GT	WHEEL & TIRE ASSY LP,15".....	2	43	96317GT	GROUND STRAP,12"LG***.....	2 <i>(to SN 50252) (30.48 cm)</i>
19	6198GT	NUT,NYLOCK,1/2-13.....	8	44	78060GT	PIN,CLEVIS,.75 DIA. X 4.00.....	1
20	6095GT	WASHER,FLAT,USS,1/2",Y.....	8	45	47520GT	WASHER,THRUST .75 X 1.25 X .06	
21	39479GT	SCREW,HHC,1/2-13 X 2.75.....	8				
22	78044GT	WELDMENT,LH STEER YOKE, 32/46*...1					
23	44781GT	KEY,RECTANGULAR,.31X.28X1.25**.....	2				
24	78222GT	SRV KIT, DRIVE MOTOR, GS32/46.....	2 <i>(to SN 45272) (includes one each items 14 and 19)</i>				
--	44782GT	SEAL KIT,DR MTR.GS15/19,Z20***.....	2 <i>(to SN 45272)</i>				
--	44783GT	BEARING,DRIVE MOTOR GS15/19.....	2 <i>(to SN 45272)</i>				
24A	96417GT	DRIVE MOTOR,18.3 CU. IN/REV.....	2 <i>(from SN 45273)</i>				
--	96419GT	SEAL KIT,RC SERIES DR MOTOR***.....	2 <i>(from SN 45273)</i>				
25	66750GT	PLATE,HOSE ROUTING, BULKHEAD...1					
		<i>(to SN 49199)</i>					
25A	58592GT	PLATE,HOSE ROUTG,BULKHEAD(PTD).....	1 <i>(from SN 49200)</i>				
26	66829GT	TUBE, CLAMP, 3/8 (PAIR).....	8 <i>(to SN 49199)</i>				
26A	78736GT	CLAMP,2 HOSE,PLASTIC,5/8.....	8 <i>(from SN 49200)</i>				
27	66986GT	FORMING,HOSE ROUTING.....	1 <i>(to SN 49199)</i>				



202.1 Ground Controls and Level Sensor Installation (to SN 1999)

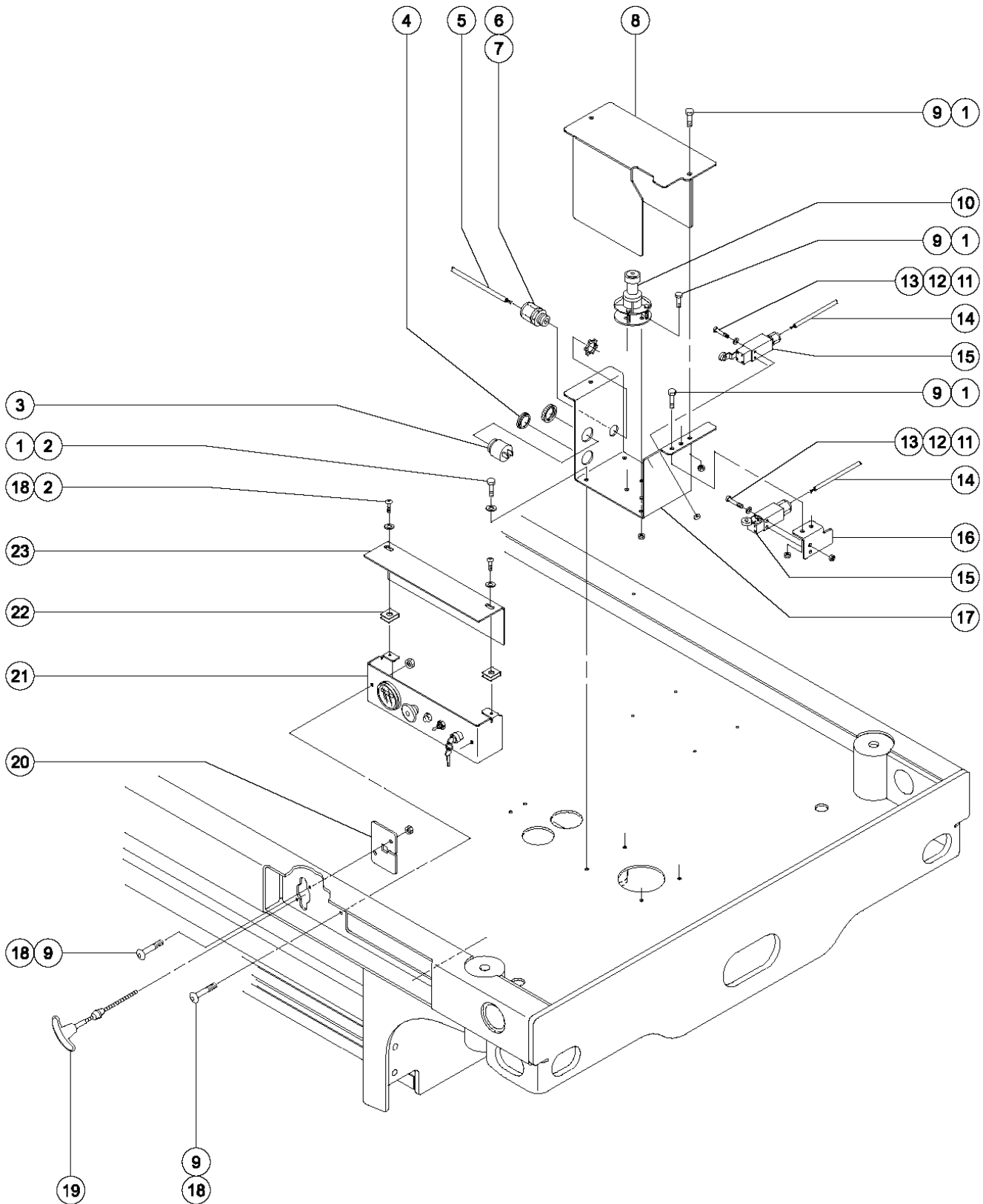

202.1 Ground Controls and Level Sensor Installation (to SN 1999)

Item	Part No.	Description	Qty.	Item	Part No.	Description	Qty.
1	8914GT	SCREW, HHC, 1/4-20 X .625.....	12	19	39232GT	CABLE,EMERGENCY DOWN.....	1
2	6356GT	WASHER, LOCK, .25.....	6			GS-2046, GS-2646 (includes mounting fasteners)	
3	39540GT	ALARM,STEADY TONE***.....	1	19A	66813GT	BUTTON,PUSH,BLACK W/SEAL***.....	1
--	72326GT	NUT - PLASTIC,RING FOR ALARMS.....	1	--	55350GT	24V,SYSTEM,E-DOWN GS3246	
4	45385GT	PLUG,NYLON 1.12 BLACK DOMED.....	1	--	66490GT	BRACKET, BATTERY MOUNTING	
		(2.84 cm)		--	66818GT	CONTACT,NC.....	1
5	39907GT	WIRE CABLE,18/2 SJO,BULK...10-inches		--	68817GT	Base - Push Button.....	1
		(25 cm)				GS-3246 (includes 1 each N.C. contact)	
6	7056GT	CONN,SQUEEZE,1/2NPT .38-.50,SM....	1	20	47194GT	PLATE,HANDLE MOUNTING.....	1
		(12.7 mm)		21		Ref. Ground Control Panel Assembly.....	1
7	6935GT	LOCKNUT,ELEC,1/2".....	1			(refer to Figure 212.1)	
8	65299GT	ENCLOSURE-LVL SENSOR		22	56912GT	SPRING CLIP,1/4-20,.025-.15X.5,	
		W/DECAL**.....	1			ZAG.....	2
9	6091GT	NUT,NYLOCK,1/4-20.....	10	23	66458GT	COVER,LOWER CONTROL PANEL ***...1	
10	40836GT	LEVEL SENSOR,LS60,BLUE,2X4**.....	1				
--	23083-SGT	FUSE HOLDER,WATERPROOF.....	1				
--	27488GT	FUSE,1 AMP.....	1				
11	51063GT	SCREW,PHILLIPS,RHM,10-32 X 1.5....	2				
		GS-2046, GA-2646					
11A	51063GT	SCREW,PHILLIPS,RHM,10-32 X 1.5....	4				
		GS-3246					
12	6146GT	WASHER,FLAT,MS,#10,Y.....	2				
		GS-2046, GA-2646					
12A	6146GT	WASHER,FLAT,MS,#10,Y.....	4				
		GS-3246					
13	6178GT	NUT,NYLOCK,10-32.....	2				
		GS-2046, GA-2646					
13A	6178GT	NUT,NYLOCK,10-32.....	4				
		GS-3246					
14	39907GT	WIRE CABLE,18/2 SJO,BULK....9-inches					
		(23 cm)					
15	96948GT	SWITCH,LIMIT,W/ROLLER ARM***.....	1				
		GS-2046, GA-2646					
--	19491GT	CONTACTOR,LIMIT SWITCH.....	2				
		GS-2046, GA-2646					
--	27643GT	ROLLER ARM-LIMIT SWITCH.....	2				
		GS-2046, GA-2646					
15A	96948GT	SWITCH,LIMIT,W/ROLLER ARM***.....	2				
		GS-3246					
--	19491GT	CONTACTOR,LIMIT SWITCH.....	2				
		GS-3246					
--	27643GT	ROLLER ARM-LIMIT SWITCH.....	2				
		GS-3246					
16	51592GT	BRACKET,LIMIT SWITCH.....	1				
17	55725GT	FORMING,LEVEL SENSOR					
		ENCLOSURE.....	1				
18	14297GT	SCREW,BHHS,1/4-20 X .75.....	4				



202.2 Ground Controls and Level Sensor Installation (from SN 2000)

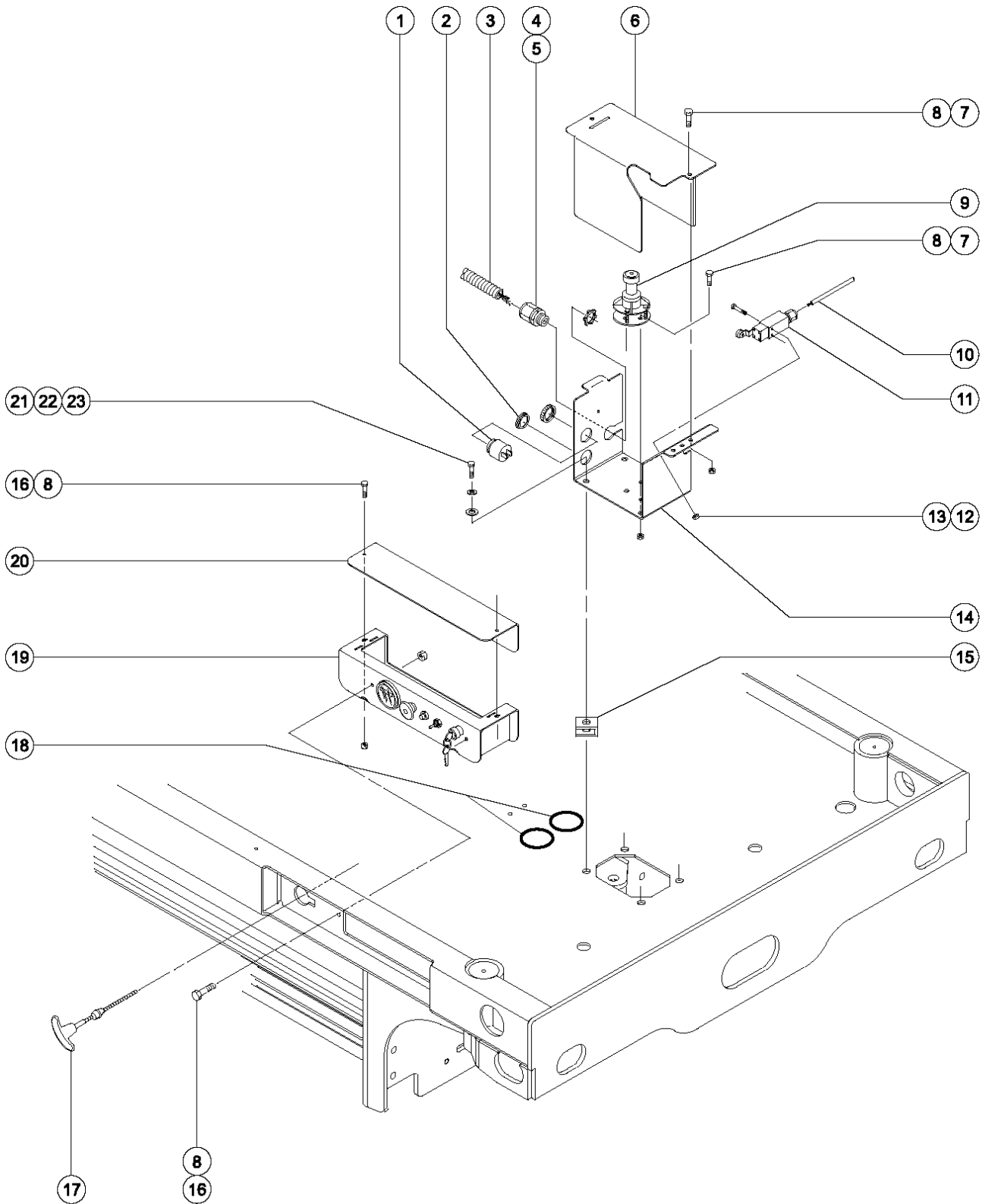

202.2 Ground Controls and Level Sensor Installation (from SN 2000)

Item	Part No.	Description	Qty.	Item	Part No.	Description	Qty.
1	39540GT	ALARM,STEADY TONE***.....1 <i>(Does not include 72326 nut)</i>	1	18	47232GT	GROMMET,RUBBER 2 X 2.75.....2 <i>(8.08 x 6.99 cm)</i>	2
--	72326GT	NUT - PLASTIC,RING FOR ALARMS.....1	1	19		Ref. Ground Control Panel.....1 <i>refer to 212.1 or 212.2</i>	1
2	45385GT	PLUG,NYLON 1.12 BLACK DOMED.....1 <i>(2.84 cm)</i>	1	20	66458GT	COVER,LOWER CONTROL PANEL ***...1 <i>GS-2046, GS-2646</i>	1
3		Ref. Wire Harness (consult factory).....1	1	20A	66462GT	LWR CONTROL PANEL COVER,GS3246.....1 <i>(from SN 28695)</i>	1
4	12960GT	CABLE SQUEEZE CONN.,XTRA LRG...1	1	21	6175GT	SCREW,HHC,3/8-16 X 1.....4	4
5	14041GT	LOCKNUT,ELECTRIC,3/4".....1	1	22	6021GT	WASHER, LOCK, .375.....4	4
6	65299GT	ENCLOSURE-LVL SENSOR W/DECAL **.....1 <i>(replaced 48356)</i>	1	23	6097GT	WASHER,FLAT,USS,3/8",Y.....4	4
7	8914GT	SCREW, HHC, 1/4-20 X .625.....1	1				
8	6091GT	NUT,NYLOCK,1/4-20.....10	10				
9	40836GT	LEVEL SENSOR,LS60,BLUE,2X4**.....1 <i>to SN 47753</i>	1				
--	23083-SGT	FUSE HOLDER,WATERPROOF.....1 <i>for 40836</i>	1				
--	27488GT	FUSE,1 AMP.....1 <i>for 40836</i>	1				
9A	78674GT	LEVEL SENSOR,LS60,BLUE,2X3**.....1 <i>from SN 47754</i>	1				
--	23083-SGT	FUSE HOLDER,WATERPROOF.....1 <i>for 78674</i>	1				
--	27488GT	FUSE,1 AMP.....1 <i>for 78674</i>	1				
10	39907GT	WIRE CABLE,18/2 SJO,BULK.....9-inches <i>(23 cm)</i>	1				
11	96948GT	SWITCH,LIMIT,W/ROLLER ARM***.....1 <i>(180 degree)</i>	1				
--	19491GT	CONTACTOR,LIMIT SWITCH.....1	1				
--	27643GT	ROLLER ARM-LIMIT SWITCH.....1	1				
12	6178GT	NUT,NYLOCK,10-32.....1	1				
13	51063GT	SCREW,PHILLIPS,RHM,10-32 X 1.5.....1	1				
14	55725GT	FORMING,LEVEL SENSOR ENCLOSURE.....1	1				
15	29868GT	SPRING CLIP,3/8-16,.05-.20X.73,ZAG...4	4				
16	6090GT	SCREW,HHC,1/4-20 X .75.....4	4				
17	39232GT	CABLE,EMERGENCY DOWN.....1 <i>GS-2046, GS-2646 (includes mounting fasteners)</i>	1				
17A	66813GT	BUTTON,PUSH,BLACK W/SEAL ***.....1 <i>GS-3246</i>	1				
--	55350GT	24V,SYSTEM,E-DOWN GS3246 <i>GS-3246 (to SN 49198)</i>	1				
--	66490GT	BRACKET, BATTERY MOUNTING <i>GS-3246 (to SN 49198)</i>	1				
--	66817GT	BASE WITH 1 NC CONTACT, E-STOP...1 <i>GS-3246 (includes 1 N.C. contact)</i>	1				
--	68818GT	Contact - N.C.....1 <i>GS-3246</i>	1				



203.1 Battery Charger

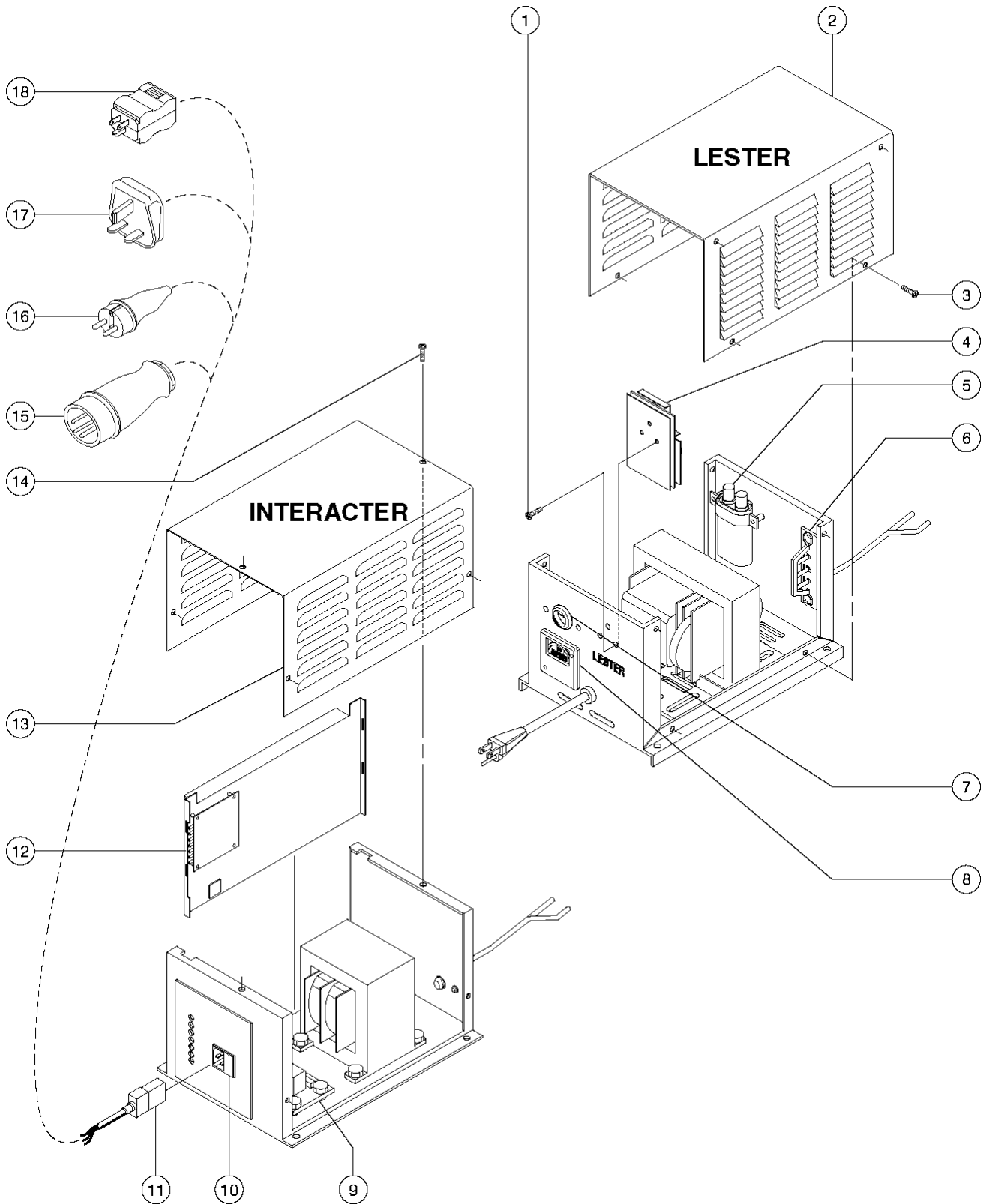



203.1 Battery Charger

Item	Part No.	Description	Qty.	Item	Part No.	Description	Qty.
A	66412GT	CHARGER,120VAC/60HZ,25A 24V*** (Lester)		17	25388GT	PLUG,FUSED,250V,13AMP,U.K.**.....1	
--	58230GT	SWITCH,STARTER,LOW VOLTAGE		--		FUSE,13 AMP,220V PLUG.....1 (component no longer available) refer to BS1362 BUSS TDC180-13A	
--	72285GT	TRANSFORMER.47906,66412,39243		18	6595GT	PLUG,ELECTRICAL,DOMESTIC.....1 (3-pin)	
--	83037GT	CORD SET, AC (66412)					
B	105739GT	CHARGER,BAT,24VDC,H/LO GEN2 power cord sold separately (worldwide, except Asia) (Interacter) (for use with maintenance-free batteries)					
--	105334GT	CONNECTOR, IEC CHARGER CORD					
--	78464-SGT	KIT,ZERO CHARGER START SWITCH					
--	96214GT	BATTERY CHARGER,UPGRADE KIT*** power cord sold separately (to SN 50318)					
C	219480GT	KIT,BATTERY CHARGER,24V (includes 105739 charger, fasteners, ring terminals and instructions for field installation)					
1	40536GT	SCREW,TIMER,#8 PHMS X.375.....3 (Lester)					
2	65432-SGT	CASE ASSY-BATTERY CHRGR**.....1 (Lester) (includes cover and base)					
3	40537GT	SCREW,CHARGER COVER,#10 X .5.....8 (Lester)					
4	62858-SGT	TIMER ASSY-ELECTRONIC, DMSTC*...1 (Lester)					
5	46335GT	CAPACITOR, 4 MFD,660VAC,39243.....1 (Lester)					
6	27262GT	HEATSINK ASSY W/DIODES (23442)....1 (Lester)					
7	13008-6GT	FUSE ASSY-BOOM CHARGER.....1 (Lester)					
8	46337GT	AMMETER, 39243/47906/66412.....1 (Lester)					
9	62237GT	CONTROL-AVS, BATT CHGR.....1 (Interacter)					
10	62233GT	CONNECTOR-IEC, BATT CHGR.....1 (Interacter)					
--	62234GT	FUSE,BATT CHGR.....1 (Interacter)					
11	51288GT	IEC PIGTAIL ***.....1 (Interacter)					
12	62231GT	HEATSINK-CNTRL ASSY,BATT CHGR.....1 (Interacter)					
13	52294GT	COVER-BATT CHGR.....1 (Interacter)					
14	12017GT	SCREW,RHM,6-32 X .25.....6 (Interacter)					
15	144161GT	PLUG,PWR,UK,16AMP,3PIN,BLK.....1					
16	6666GT	PLUG,ELECTRICAL,220/50,NOVON.....1					



203.2 Battery Charger, 110V AC, Asia

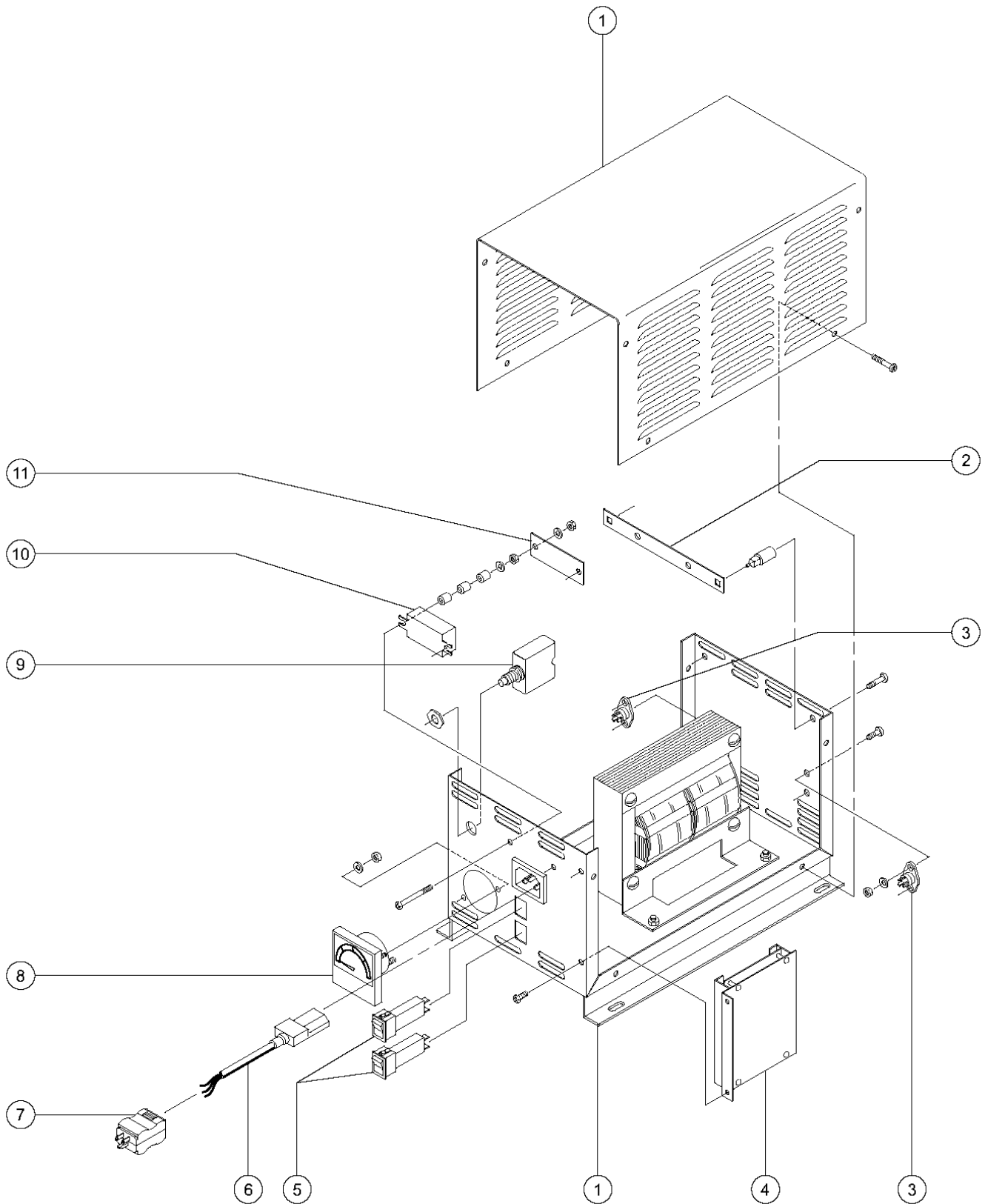

A TEREX BRAND

203.2 Battery Charger, 110V AC, Asia

Item	Part No.	Description	Qty.
--	48282GT	POWER CORD, IEC 320 BLANK	
--	55620GT	CHARGER-BATT, DUAL VOLT** (Asia) (Lester)	
--	96214GT	BATTERY CHARGER,UPGRADE KIT*** <i>power cord sold separately</i>	
1	52168GT	CASE ASSEMBLY, 47671 CHARGER.....1 <i>(includes cover and base)</i>	
2	52169GT	SHUNT,ELECTRONIC,47671 CHARGER.....1	
3	52175GT	SCR ASSY,47671 LESTER CHARGER.....2	
4	52170GT	TIMER ASSY,ELECTRONIC,47671.....1	
5	52173GT	CIRCUIT BREAKER-CHARGER, 8 AMP.....2	
6	51288GT	IEC PIGTAIL ***.....1	
7	6595GT	PLUG,ELECTRICAL,DOMESTIC.....1	
--		FUSE,13 AMP,220V PLUG.....1 <i>(component no longer available) refer to BS1362 BUSS TDC180-13A</i>	
--	144161GT	PLUG,PWR,UK,16AMP,3PIN,BLK.....1	
--	25388GT	PLUG,FUSED,250V,13AMP,U.K.**.....1	
--	6666GT	PLUG,ELECTRICAL,220/50,NOVON....1	
8	52172GT	AMMETER-47671 CHARGER,25 AMP...1	
9	52174GT	CIRCUIT BREAKER-CHARGER,45 AMP.....1	
10	52176GT	RELAY,CHARGR,47671,DPDT,110VDC.1	
11	52171GT	PCB,RELAY DRIVER,CHARGER 47671.....1	

203.3 Battery Charger, 220V AC, European

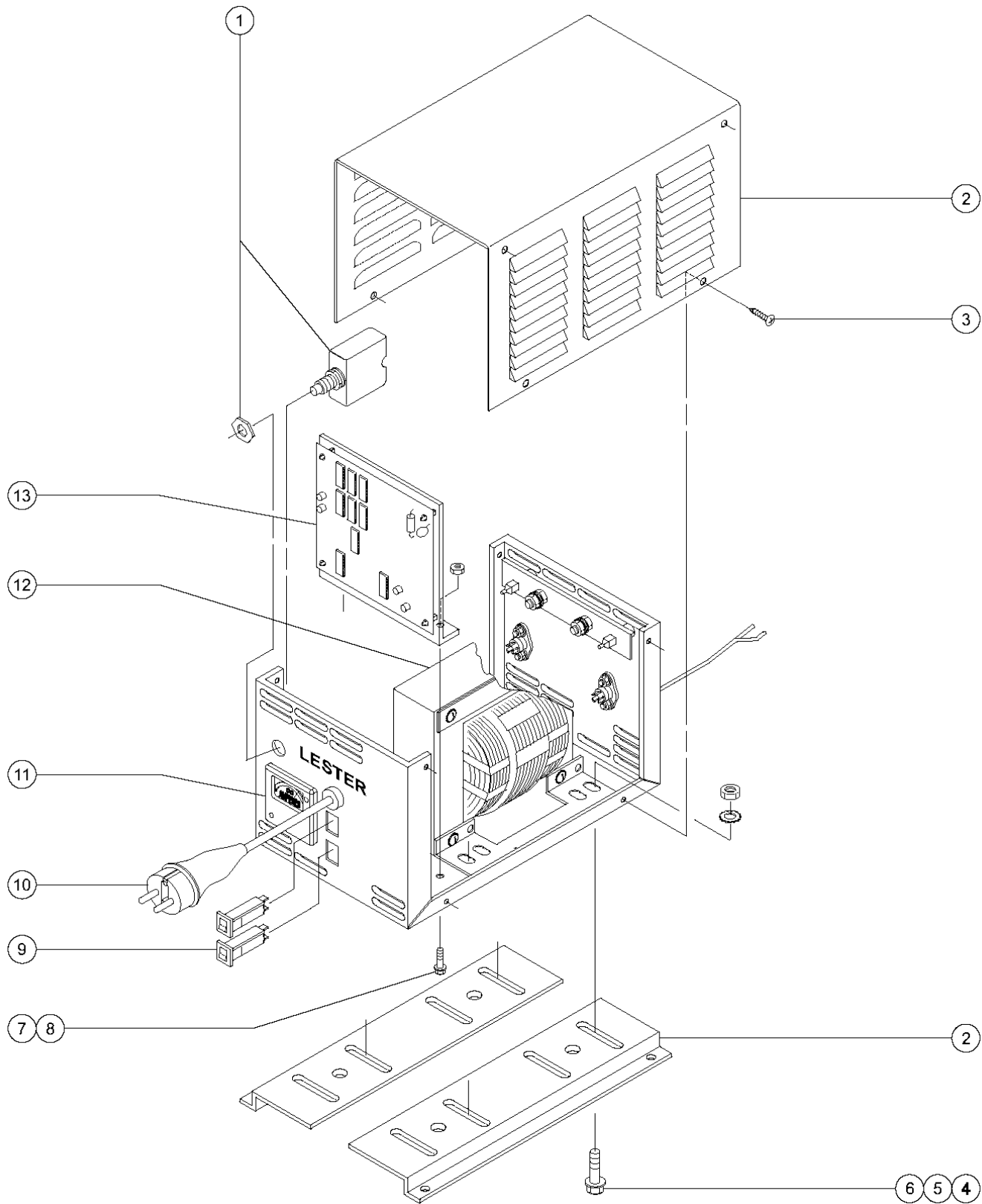

## 203.3 Battery Charger, 220V AC, European

Item	Part No.	Description	Qty.
--	105739GT	CHARGER,BAT,24VDC,H/LO GEN2 <i>power cord sold separately</i>	
--	66478GT	BATTERY CHARGER, CONT EUROPE <i>(Lester)</i>	
--	96214GT	BATTERY CHARGER,UPGRADE KIT*** <i>power cord sold separately</i>	
1	69585GT	CIRCUIT BREAKER,50A,50VAC.....	1
2	69580GT	CASE ASSY,BATT CHARGER (66478)..... <i>(includes cover and mounting brackets)</i>	1
3	69581GT	TUBE, PLATFORM SPACER STD-12P...8	
4	69582GT	SCREW,HHC,WASH HEAD,1/4-20X.63.....	4
5	69586GT	WASHER,STAR,EXTERNAL,.25.....	4
6	6357GT	NUT,HEX,1/4-20.....	4
7	69583GT	SCREW,HEX INDENT,8-32 X 5/16.....	2
8	18542GT	NUT,HEX,8-32.....	2
9	52173GT	CIRCUIT BREAKER-CHARGER, 8 AMP.....	2
10	55019GT	POWER CORD,NOVON***.....	1
--	66666GT	SPRING, COMPRESSION.....	1
11	52172GT	AMMETER-47671 CHARGER,25 AMP...1	
12	69584GT	TRANSFORMER,CHARGER (66478).....	1
13	52170GT	TIMER ASSY,ELECTRONIC,47671.....	1

203.4 Battery Charger - Domestic and Worldwide

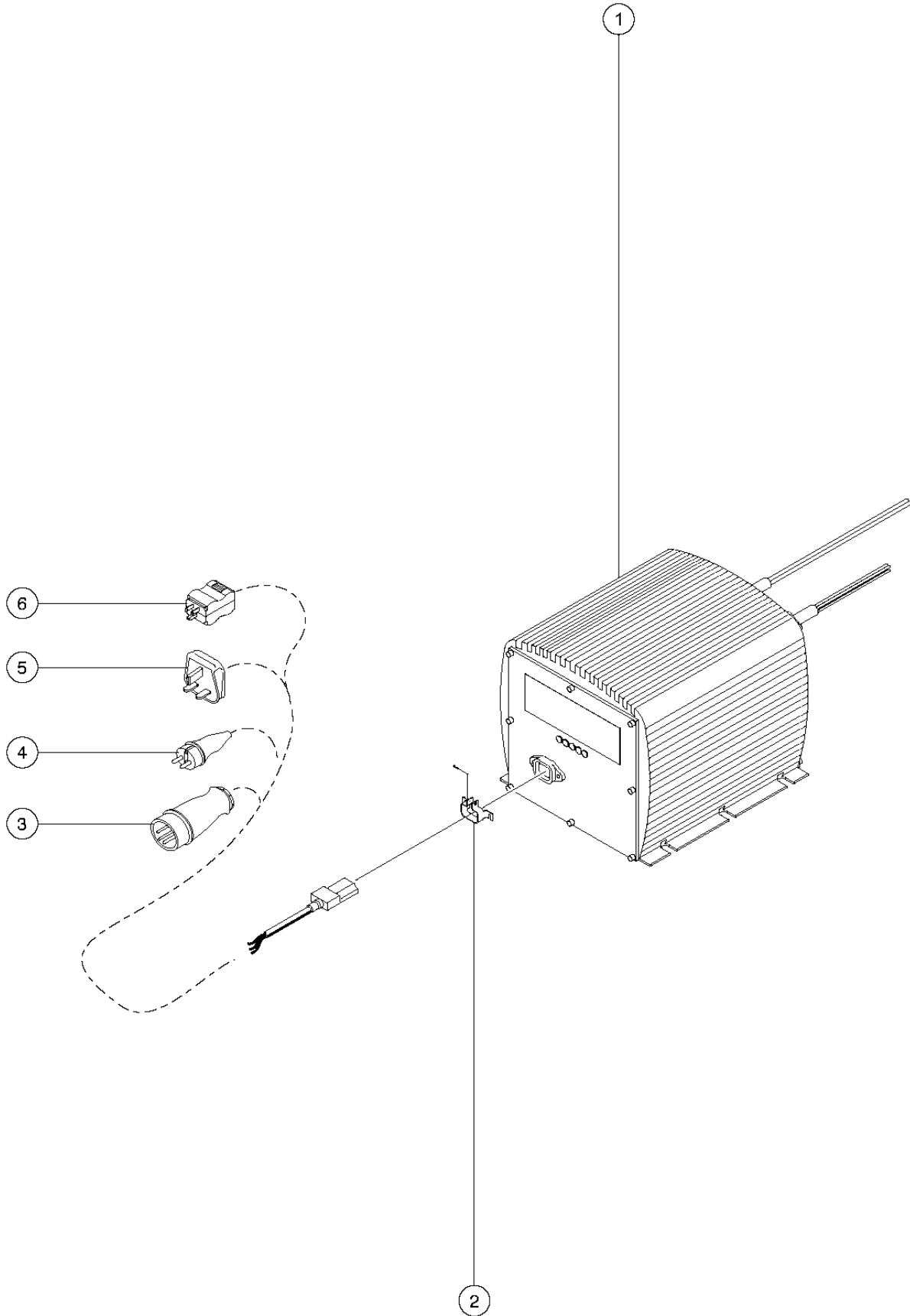

203.4 Battery Charger - Domestic and Worldwide

Item	Part No.	Description	Qty.
--	105334GT	CONNECTOR, IEC CHARGER CORD <i>for 5-LED battery charger</i>	
--	97059GT	FUSE,BATTERY CHARGER*** <i>for 5-LED battery charger</i>	
1	105739GT	CHARGER,BAT,24VDC,H/LO GEN2.....1	
--	144180GT	MANUAL,OWNERS,CHARGER,105739	
2	55010GT	LOCK, CONNECTOR.....1 <i>(includes fasteners)</i>	
3	71706GT	POWER CORD, UK 110.....1	
4	55019GT	POWER CORD,NOVON*** .....1	
5	55018GT	POWER CORD,UK-HIGH VOLTAGE*** .....1	
6	55021GT	POWER CORD,US 110*** .....1	

204.1 Battery Pack Module Tray Installation (to SN 36044)

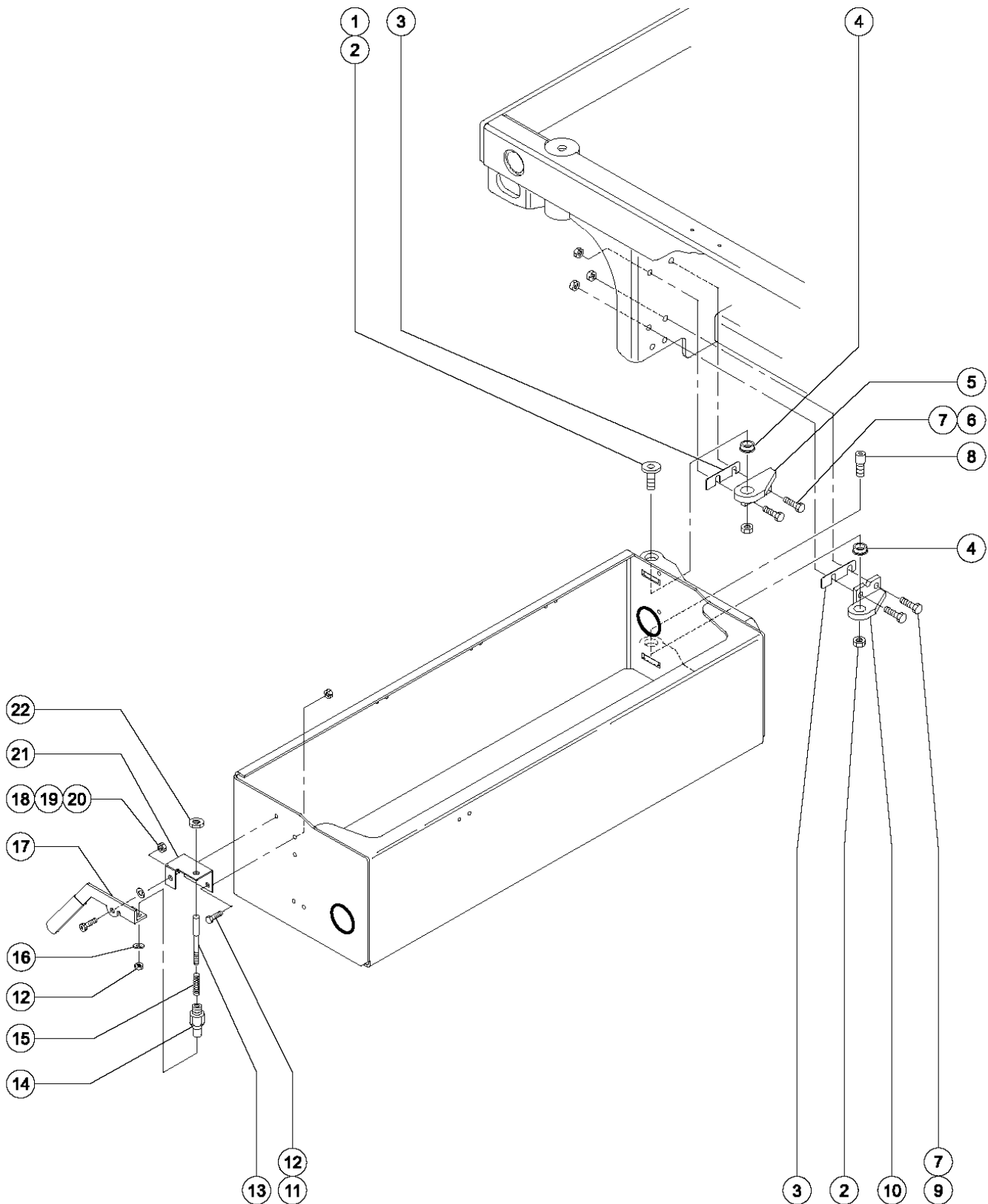



## 204.1 Battery Pack Module Tray Installation (to SN 36044)

Item	Part No.	Description	Qty.
1	47255GT	BOLT,SHORT SHOULDER.....	1
2	38028GT	NUT,LP NYLOCK,5/8-11.....	2
3	47342GT	SPACER,MODULE TRAY,.030 THK..... <i>(Quantity listed for this item is approximate. Actual quantity may vary to ensure proper fit.)</i>	2
3A	47455GT	SPACER,MODULE TRAY,.075 THK..... <i>(Quantity listed for this item is approximate. Actual quantity may vary to ensure proper fit.)</i>	2
4	47548GT	BEARING,FL,0.75ID X 1 OD X .49..... <i>(1.91 x 2.54 x .95 cm)</i>	2
5	47324GT	BRACKET,BOX HINGE,LH-UP/RH-LO...	1
6	10597GT	SCREW,HHC,1/2-13 X 1.25 GR5.....	2
7	6086GT	NUT,LP NYLOCK,1/2-13.....	4
8	55983GT	PIN-THREADED SHLDR OFFS,5/8-11...	1
9	8177GT	SCREW,HHC,1/2-13 X 1.5.....	2
10	47323GT	BRACKET,BOX HINGE,RH-UP/LH-LO...	1
11	33681GT	SCREW,HHC,3/8-16 X .625.....	2
12	7713GT	NUT, LP NYLOCK, 3/8-16.....	3
13	39470GT	PIN, LOCK.....	1
14	41630GT	HOUSING, LOCK PIN.....	1
15	39469GT	SPRING,COMPRESSION.485 X1.75**...	1
16	6097GT	WASHER,FLAT,USS,3/8",Y.....	1
17	46347GT	HANDLE-LOCK,BATT.MOD,LEFT SIDE..... <i>(battery pack side)</i>	1
--	44733GT	HANDLE COVER,PLASTIC.....	1
--	47326GT	HANDLE,LOCK PIN,LT.....	1
18	6782GT	NUT,NYLOCK,5/16-18.....	1
19	47228GT	WASHER,NYLON,.406 X.750 X.032.....	1
20	47227GT	SCREW,SHS,5/16-18 X .375.....	1
21	47325GT	BRACKET,LOCK PIN,LEFT..... <i>(battery pack side)</i>	1
22	8538GT	NUT,LP NYLOCK,3/4-10.....	1

204.2 Battery Pack Module Tray Installation (from SN 36045)

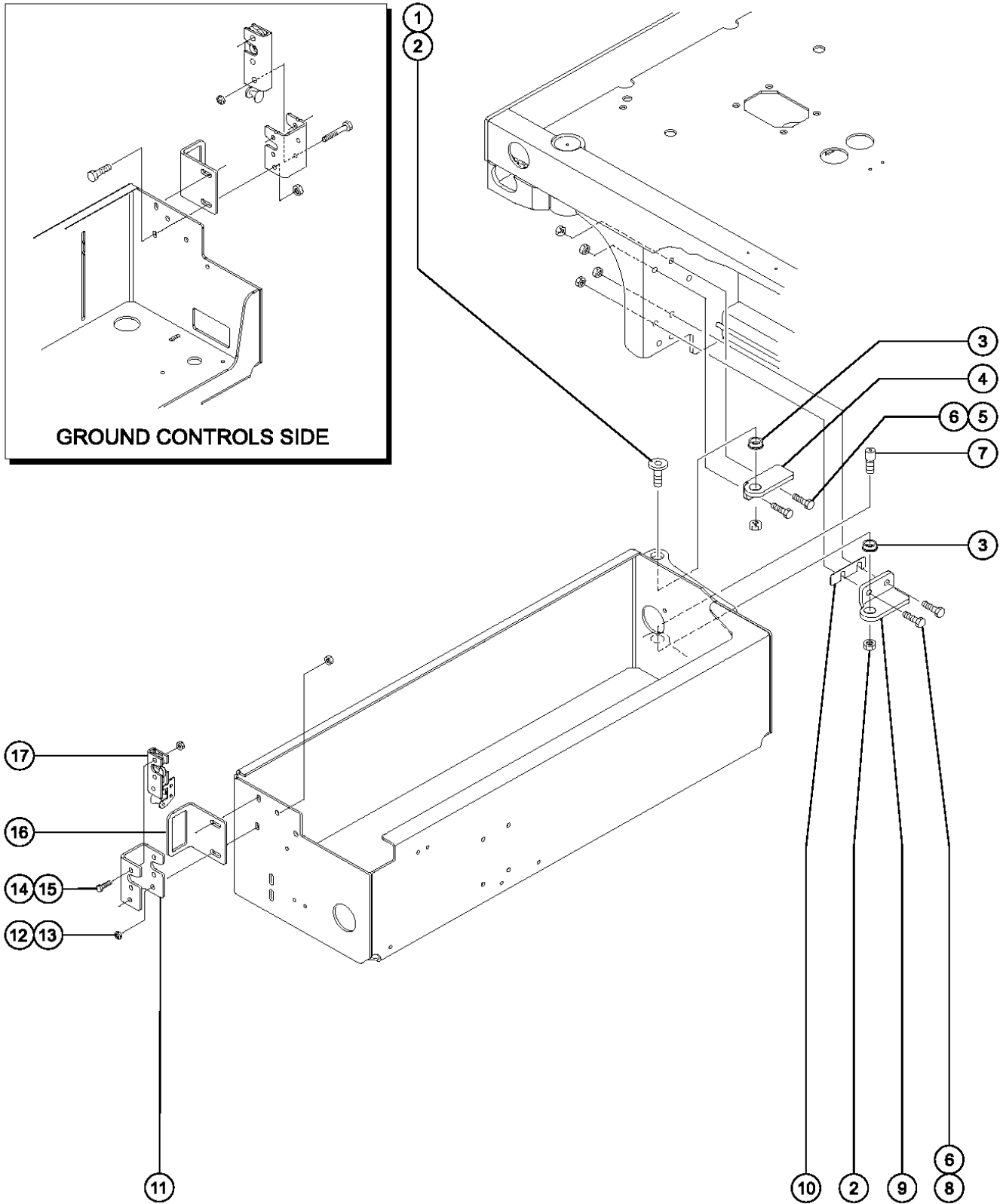

## 204.2 Battery Pack Module Tray Installation (from SN 36045)

Item	Part No.	Description	Qty.
--	65971-SGT	HANDLE-ROTATOR LATCH ASSY LS** <i>(battery pack side) (includes items 11-17)</i>	
--	65972-SGT	HANDLE-ROTATOR LATCH ASSY RS** <i>(ground controls side)</i>	
1	47255GT	BOLT,SHORT SHOULDER.....1	
2	38028GT	NUT,LP NYLOCK,5/8-11.....2	
3	47548GT	BEARING,FL,0.75ID X 1 OD X .49.....2 <i>(1.91 x 2.54 x 0.97 cm)</i>	
4	47324GT	BRACKET,BOX HINGE,LH-UP/RH-LO....1	
5	10597GT	SCREW,HHC,1/2-13 X 1.25 GR5.....2	
6	6086GT	NUT,LP NYLOCK,1/2-13.....4	
7	55983GT	PIN-THREADED SHLDR OFFS,5/8-11...1	
8	51496GT	SCREW,HHC,1/2-13 X 1.375.....2	
9	47323GT	BRACKET,BOX HINGE,RH-UP/LH-LO....1	
10	47342GT	SPACER,MODULE TRAY,.030 THK.....2 <i>(Quantity listed for this item is approximate. Actual quantity may vary to ensure proper fit.)</i>	
10A	47455GT	SPACER,MODULE TRAY,.075 THK.....2 <i>(Quantity listed for this item is approximate. Actual quantity may vary to ensure proper fit.)</i>	
11	65982GT	BRACKET-LATCH MOUNT,BAT MOD.....1	
12	6782GT	NUT,NYLOCK,5/16-18.....1	
13	13002GT	SCREW,HHC,5/16-18 X 1 GR5.....2	
14	13000GT	SCREW,HHC,5/16-18 X 1.25.....2	
15	6002GT	NUT,LP NYLOCK,5/16-18.....2	
16	66871GT	FORMING, MOD TRAY HANDLE.....1	
17	66900GT	LATCH,ROTARY, W/KNOB, LEFT.....1 <i>(battery pack side) (shown)</i>	
17A	66901GT	LATCH,ROTARY,W/KNOB,RIGHT.....1 <i>(ground controls side)</i>	

205.1 Battery Pack Module (to SN 35799)

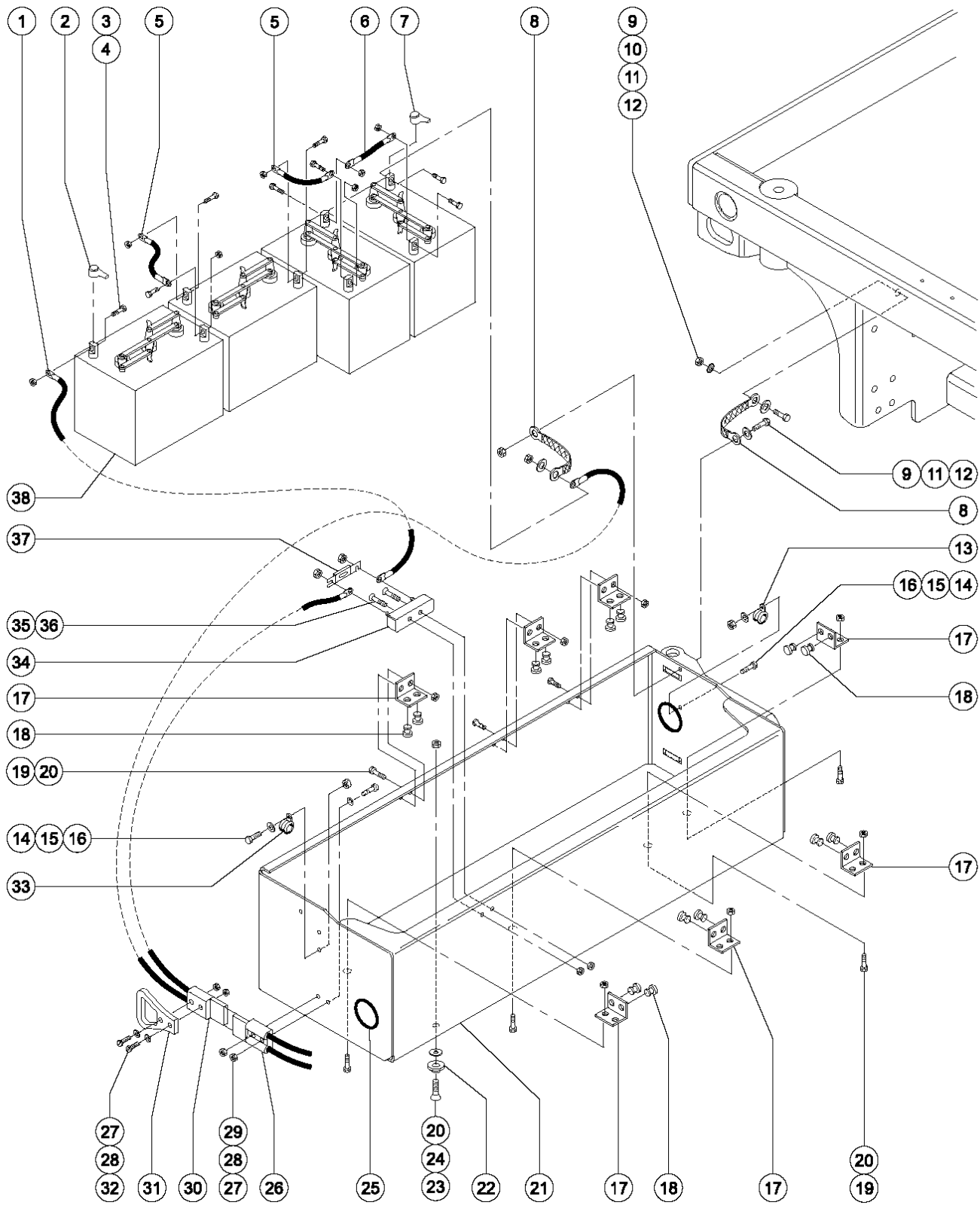

205.1 Battery Pack Module (to SN 35799)

Item	Part No.	Description	Qty.	Item	Part No.	Description	Qty.
1		Ref. Battery Cable Assembly <i>(refer to Figure 214.1 and 214.2)</i>		35	6873GT	SCREW,FHM,10-32 X 1.....	2
2	96110GT	BOOT,CABLE TERMINAL COVER.....	9	36	6178GT	NUT,NYLOCK,10-32.....	2
3	13002GT	SCREW,HHC,5/16-18 X 1 GR5.....	8	37	40833GT	FUSE,275 AMP,VERY FAST ACTING.....	1
4	18503GT	NUT,LOCKING-LG.FLANGE,5/16-18.....	8	38	76502GT	BATTERY,T105 W/LPT,3 CAP,DRY**.....	4
5		Ref. Battery Cable Assembly..... <i>(refer to Figure 214.1 and 214.2)</i>	8			<i>Case size: 10 3/8 x 7 1/2 x 10 5/8 inches (26.4 x 19.05 x 26.98 cm)</i>	
6		Ref. Battery Cable Assembly..... <i>(refer to Figure 214.1 and 214.2)</i>	8				
7	51147GT	BOOT,CABLE TERMINAL,LG,RED,2/0...1					
8	39532GT	GROUND STRAP.....	2				
9	7713GT	NUT, LP NYLOCK, 3/8-16.....	2				
10	6700GT	WASHER,STAR,EXTERNAL,,375.....	2				
11	6097GT	WASHER,FLAT,USS,3/8",Y.....	2				
12	6175GT	SCREW,HHC,3/8-16 X 1.....	2				
13	18666GT	CLAMP,1.00,#16 X 1/4,RUB CUSH..... <i>(2.5 cm)</i>	1				
14	6090GT	SCREW,HHC,1/4-20 X .75.....	2				
15	6638GT	WASHER,FLAT,USS,1/4"Y.....	2				
16	6091GT	NUT,NYLOCK,1/4-20.....	2				
17	66427GT	SERVICE KIT, BATTERY STOP.....	7				
--	47480GT	FORMING,BATTERY STOP.....	7				
18	47478GT	BUMPER,RUBBER,1"OD X .461 H..... <i>(2.5 cm)</i>	14				
19	19284GT	SCREW,FHS,1/4-20 X .63.....	14				
20	6889GT	NUT,LP NYLOCK,1/4-20.....	15				
21	48334GT	BATT.MODULE ASSY W/DECAL-2032...1 <i>(bearing shown in 204.1) (includes 15 each itemr 20 and items 22-25)</i>					
22	47793GT	BUMPER, MODULE TRAY.....	1				
23	8514GT	SCREW,FHS,1/4-20 X .75.....	1				
24	12906GT	WASHER,FENDER,.25 X 1.25 X.062.....	1				
25	47232GT	GROMMET,RUBBER 2 X 2.75..... <i>(5.1 x 7 cm)</i>	2				
26		Ref. Battery Cable Assembly..... <i>(refer to Figure 214.1 and 214.2)</i>	2				
27	6357GT	NUT,HEX,1/4-20.....	4				
28	6356GT	WASHER, LOCK, .25.....	4				
29	8915GT	SCREW,HHC,1/4-20 X 1.25.....	2				
30		Ref. Battery Cable Assembly..... <i>(refer to Figure 214.1 and 214.2)</i>	2				
31	44716GT	HANDLE,ANDERSON CONNECTOR SB.....	1				
32	11966GT	SCREW,BHHS,1/4-20 X 1.5.....	2				
33	45454GT	CLAMP,0.75,#12 X 3/8,RUB CUSH*..... <i>(1.9 cm)</i>	1				
34	66717GT	FUSE BLOCK, ANN & ANL FUSE..... <i>(includes mounting fasteners)</i>	1				



205.2 Battery Pack Module (from SN 35800)

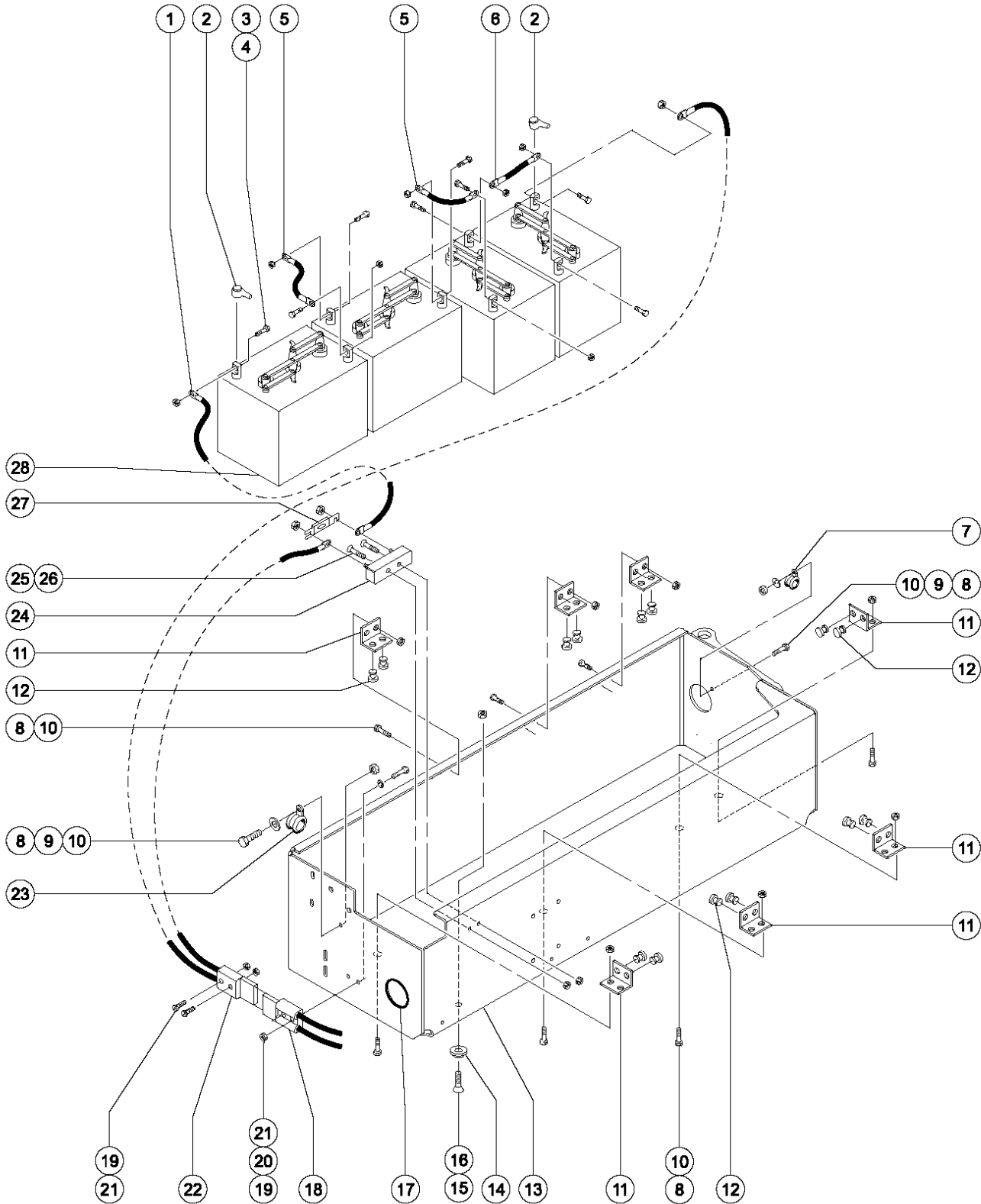

## 205.2 Battery Pack Module (from SN 35800)

Item	Part No.	Description	Qty.
1		Ref. Battery Cable Assembly (refer to Figure 214.2)	
2	96110GT	BOOT,CABLE TERMINAL COVER.....9	
3	13002GT	SCREW,HHC,5/16-18 X 1 GR5.....8	
4	18503GT	NUT,LOCKING-LG.FLANGE,5/16-18....8	
5		Ref. Battery Cable Assembly.....8 (refer to Figure 214.2)	
6		Ref. Battery Cable Assembly.....8 (refer to Figure 214.2)	
7	18666GT	CLAMP,1.00,#16 X 1/4,RUB CUSH.....1 (2.5 cm)	
8	6090GT	SCREW,HHC,1/4-20 X .75.....2	
9	6638GT	WASHER,FLAT,USS,1/4"Y.....2	
10	6091GT	NUT,NYLOCK,1/4-20.....2	
11	66427GT	SERVICE KIT, BATTERY STOP.....7	
--	47480GT	FORMING,BATTERY STOP.....7	
12	47478GT	BUMPER,RUBBER,1"OD X .461 H.....14	
13	48334GT	BATT.MODULE ASSY W/DECAL-2032...1 (includes items 14-17) (bearings are shown in 204.1)	
14	47793GT	BUMPER, MODULE TRAY.....1	
15	8514GT	SCREW,FHS,1/4-20 X .75.....1	
16	6889GT	NUT,LP NYLOCK,1/4-20.....15	
17	47232GT	GROMMET,RUBBER 2 X 2.75.....2 (5.1 x 7 cm)	
18		Ref. Battery Cable Assembly.....2 (refer to Figure 214.2)	
19	66094GT	NUT-THIN HEAVY HEX, 1/4-20.....4	
20	6356GT	WASHER, LOCK, .25.....2	
21	8915GT	SCREW,HHC,1/4-20 X 1.25.....4	
22		Ref. Battery Cable Assembly.....2 (refer to Figure 214.2)	
23	45454GT	CLAMP,0.75,#12 X 3/8,RUB CUSH*.....1 (1.9 cm)	
24	66717GT	FUSE BLOCK, ANN & ANL FUSE.....1	
25	6782GT	NUT,NYLOCK,5/16-18.....2	
26	13000GT	SCREW,HHC,5/16-18 X 1.25.....2	
27	40833GT	FUSE,275 AMP,VERY FAST ACTING....1	
28	76502GT	BATTERY,T105 W/LPT,3 CAP,DRY**.....4 Case size: 10 3/8 x 7 1/2 x 10 5/8 inches (26.4 x 19.05 x 26.98 cm)	

206.1 Non-steer Axle and Brake Release Hand Pump Installation

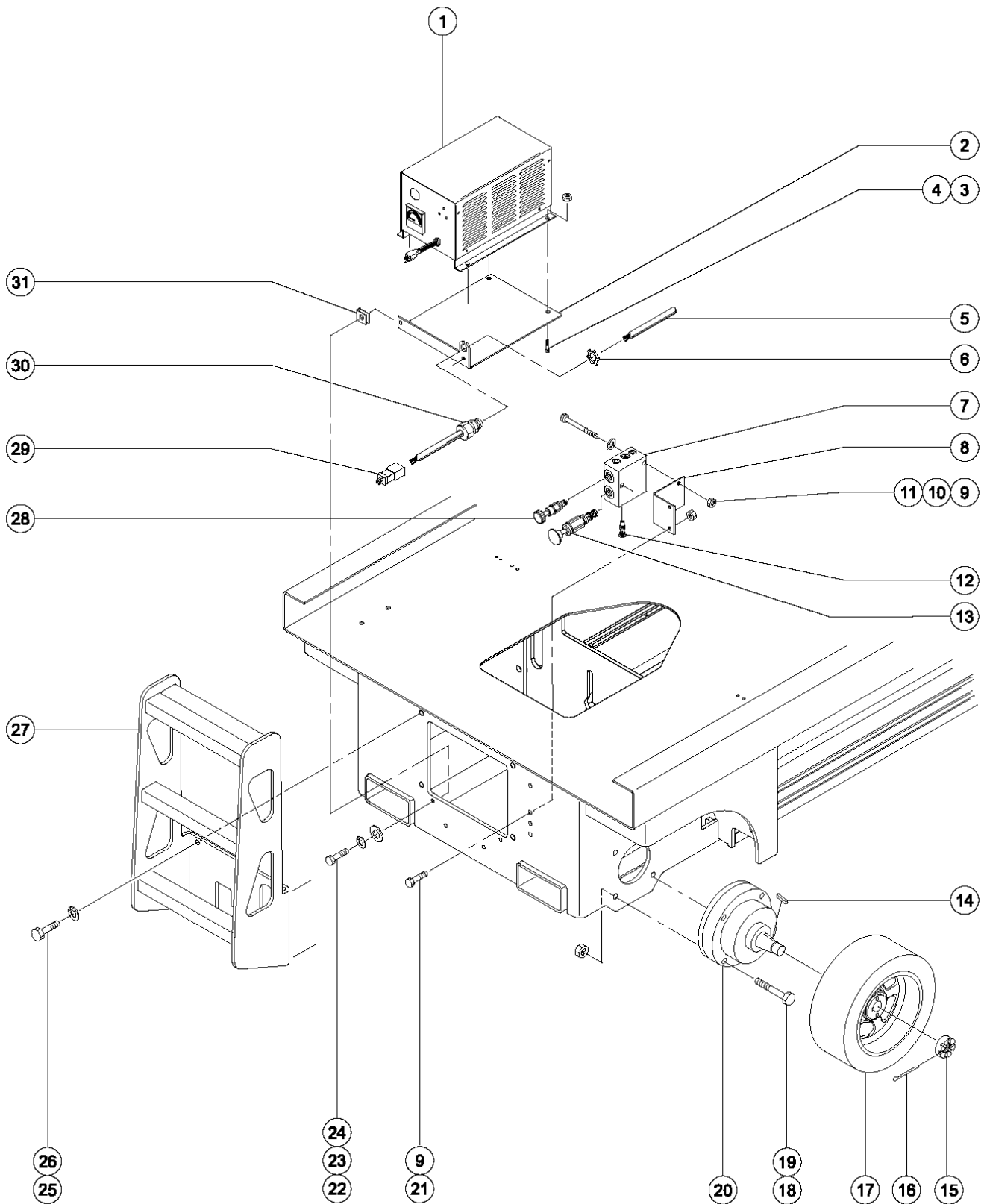



206.1 Non-steer Axle and Brake Release Hand Pump Installation

Item	Part No.	Description	Qty.	Item	Part No.	Description	Qty.
1		Ref. Charger - Battery <i>(refer to Figure 203.1, 203.2 or 203.3)</i>		27	48355GT	LADDER ASSY W/DECALS GS32/46**.....	1
2	39271GT	CHARGER MOUNT PLATE.....	1	28	44217GT	VALVE,CHECK,PILOT OPERATED***.....	1
3	6090GT	SCREW,HHC,1/4-20 X .75.....	4	--	44233GT	SEAL KIT-FOR PN. 44217.....	1
4	6091GT	NUT,NYLOCK,1/4-20.....	4	--	65763GT	KNOB,BLACK(44217)CHECK VALVE.....	1
5	43956GT	WIRE CABLE,14/3 CON.TPE JKT*.....	444-inches (11.28 m)	29	6595GT	PLUG,ELECTRICAL,DOMESTIC.....	1
5A	43956GT	WIRE CABLE,14/3 CON.TPE JKT*.....	504-inches (12.8 m)	29A	6666GT	PLUG,ELECTRICAL,220/50,NOVON.....	1
5B	43956GT	WIRE CABLE,14/3 CON.TPE JKT*.....	624-inches (15.85 m)	29B	25388GT	PLUG,FUSED,250V,13AMP,U.K.**.....	1
6	6935GT	LOCKNUT,ELEC,1/2".....	1	29C		FUSE,13 AMP,220V PLUG.....	1
7	96461GT	SERVICE KIT,BRAKE RELEASE MAN*..... <i>(to SN 60878) (includes items 12, 13 and 28)</i>	1	30	7056GT	CONN,SQUEEZE,1/2NPT .38-.50,SM....	1
8	66825GT	FORMING, HAND PUMP BRACKET.....	1	31	56912GT	SPRING CLIP,1/4-20,.025-.15X.5, ZAG.....	2
9	4828GT	NUT,NYLOCK,3/8-16.....	6				
10	6097GT	WASHER,FLAT,USS,3/8",Y.....	2				
11	14033GT	SCREW,HHC,3/8-16 X 2.75.....	2				
12	44216GT	VALVE,SHUTTLE.....	1				
--	44235GT	SEAL KIT-FOR PN.44216 & 826779.....	1				
13	44218GT	VALVE,HAND PUMP**.....	1				
--	44224GT	SEAL KIT, VALVE.....	1				
--	58992GT	KNOB,RED(44218)HP VALVE.....	1				
14	44781GT	KEY,RECTANGULAR,.31X.28X1.25**..... <i>(0.31 x 0.28 x 1.25 inches)</i>	2				
15	44780GT	NUT,CASTLE,1.125-18 UNEF.....	2				
16	42079GT	PIN,COTTER,.156 X 2.5.....	2				
17	105454GT	WHEEL & TIRE ASSY LP,15".....	2				
18	8220GT	SCREW,HHC,1/2-13 X 4.....	8				
19	66777GT	NUT,TOP LOCK,1/2-13.....	8				
20	96416GT	SERVICE KIT,BRAKE,14.2 IN 3***..... <i>to SN 49846 (Ausco-Mico) (contains two brakes and mounting hardware)</i>	1				
--	88000GT	SEAL KIT (66419, 66416, 74297)..... <i>(to SN 49846) (Ausco)</i>	2				
20A	96257GT	BRAKE, HYDRAULIC***..... <i>from SN 49846 (White)</i>	2				
21	6175GT	SCREW,HHC,3/8-16 X 1.....	2				
22	6888GT	SCREW,HHC,1/4-20 X 1.....	2				
23	6356GT	WASHER, LOCK, .25.....	2				
24	6638GT	WASHER,FLAT,USS,1/4"Y.....	2				
25	10597GT	SCREW,HHC,1/2-13 X 1.25 GR5.....	4				
26	6033GT	WASHER,LOCK,0.5".....	4				



207.1 Pothole Protection Assembly and Counterweights (to SN 35799)

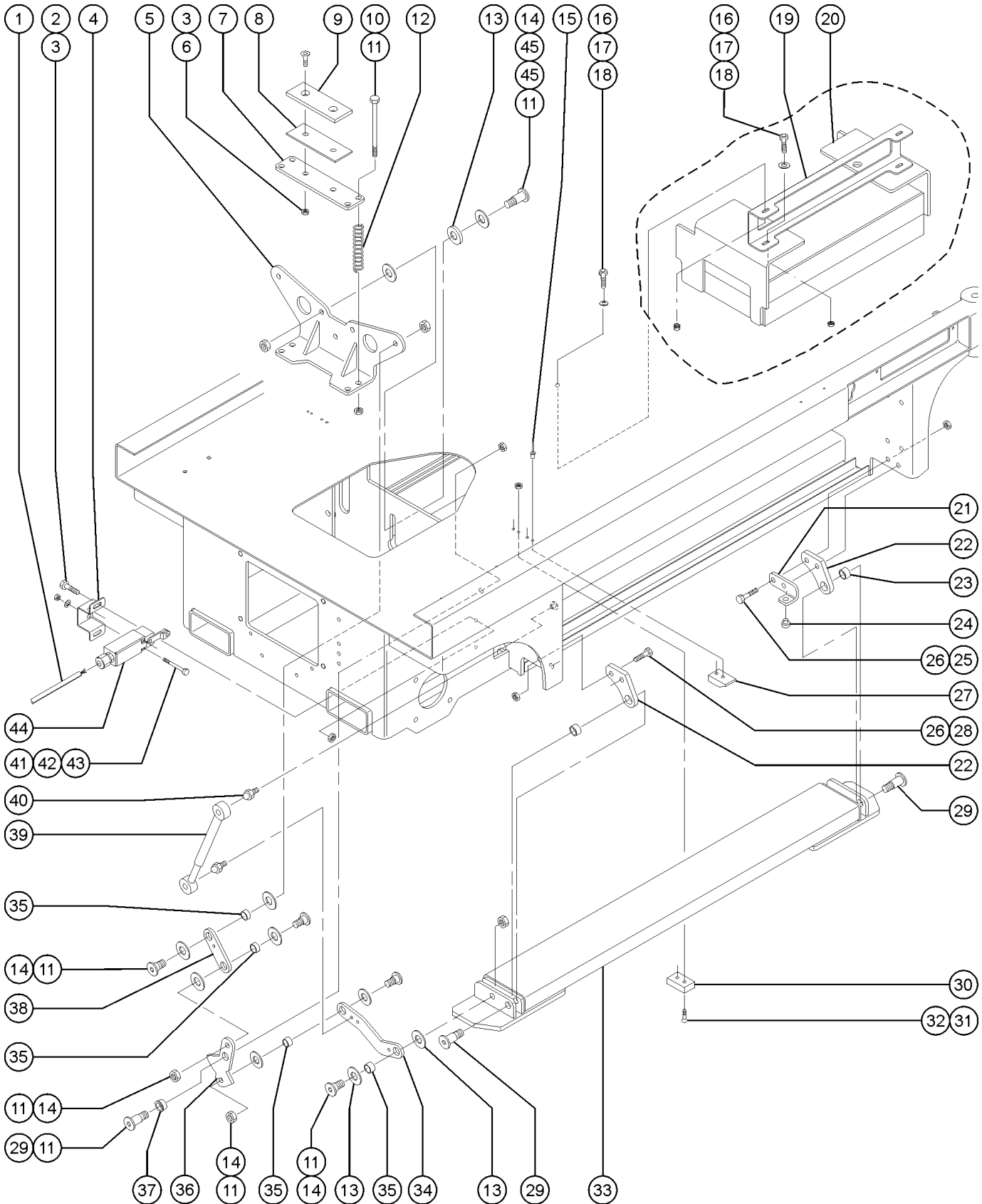

207.1 Pothole Protection Assembly and Counterweights (to SN 35799)

Item	Part No.	Description	Qty.	Item	Part No.	Description	Qty.
1	39907GT	WIRE CABLE,18/2 SJO,BULK...86-inches (2.18 m) (ground controls side) (shown)		24	47230GT	BUMPER,RUBBER.....	2
1A	39907GT	WIRE CABLE,18/2 SJO,BULK...62-inches (1.58 m) (battery pack side)		25	8177GT	SCREW,HHC,1/2-13 X 1.5.....	4
2	6175GT	SCREW,HHC,3/8-16 X 1.....	4	26	6086GT	NUT,LP NYLOCK,1/2-13.....	8
3	4828GT	NUT,NYLOCK,3/8-16.....	6	27	39317GT	STOP PLATFORM ROLLER..... (tapered)	2
4	47274GT	BRACKET,POTHOLE SWITCH.....	2	28	51496GT	SCREW,HHC,1/2-13 X 1.375.....	4
5	47539GT	WELDMENT,POTHOLE ACTUATOR,46.....	1	29	71912GT	BOLT,SHOULDER,5/8-11 X 1.19 LT.....	6
6	35463GT	SCREW,FHS,3/8-16 X 1.5.....	2	30	47907GT	BLOCK,MODULE TRAY STOP.....	2
7	47540GT	PLATE,POTHOLE ACTUATOR,46.....	2	31	40594GT	SCREW,FHS,1/4-20 X 1.25.....	4
8	47414GT	PLATE,POTHOLE PAD SPACER, 32..... (Quantity listed for this item is approximate. Actual quantity may vary to ensure proper fit)	1	32	6091GT	NUT,NYLOCK,1/4-20.....	4
9	47322GT	WEAR PAD,POTHOLE..... (15.2 x 6.4 x 1 cm)	1	33	47244GT	POTHOLE WELDMENT,RIGHT,32..... (ground controls side) (shown)	1
10	47593GT	SCREW,HHC,5/8-11 X 10.....	4	33A	47243GT	POTHOLE WELDMENT,LEFT,32/46..... (battery pack side)	1
11	38028GT	NUT,LP NYLOCK,5/8-11.....	17	34	48325GT	PLATE,POTHOLE LINK,LWR.W/BUSH..... (includes 2 each item 35)	2
12	47541GT	SPRING,DIE 1.25 X 8.0..... (20.3 cm)	4	35	39580GT	BEARING,0.75IDX1.00ODX0.38L..... (1.91 x 2.54 x 0.97 cm)	8
13	51146GT	SPACER,.75IDX.875ODX.375..... (1.9 x 2.2 x 1 cm)	22	36	48326GT	ARM, POTHOLE CRANK, GS32/46..... (shown) (ground controls side) (includes item 37)	1
14	47255GT	BOLT,SHORT SHOULDER.....	11	36A	48359GT	ARM,L POTHOLE CRANK, GS32/46..... (battery pack side) (includes item 37)	1
15	41695GT	RIVET,STL,STL,.188 X .50.....	4	37	47548GT	BEARING,FL,0.75ID X 1 OD X .49..... (1.9 x 2.5 x 1 cm)	2
16	6019GT	SCREW,HHC,3/8-16 X 1.25 GRD 5.....	4	38	48327GT	PLATE,POTHOLE LINK,UPR.W/BEAR..... (includes item 35)	2
17	6097GT	WASHER,FLAT,USS,3/8",Y.....	4	39	39542GT	GAS SHOCK,SCISSORS***.....	2
18	4828GT	NUT,NYLOCK,3/8-16.....	4	40	40265GT	BALL STUD,GAS STRUT (38593)***.....	4
19	66452GT	BRACKET, COUNTERWEIGHT, GS3246..... (from SN 24439)	1	41	51063GT	SCREW,PHILLIPS,RHM,10-32 X 1.5.....	4
20	66453GT	WELDMENT,COUNTERWEIGHT 575 LBS..... GS-2646 CE (between fork tubes)	1	42	6146GT	WASHER,FLAT,MS,#10,Y.....	4
20A	66453GT	WELDMENT,COUNTERWEIGHT 575 LBS..... GS-3246 (between fork tubes)	1	43	6178GT	NUT,NYLOCK,10-32.....	4
20B	66430GT	COUNTERWEIGHT, LARGE, GS32..... GS-3246 (inside chassis above hydraulic tray)	2	44	96948GT	SWITCH,LIMIT,W/ROLLER ARM***.....	2
21	47656GT	BRACKET,POTHOLE STOPPER,LEFT..... (ground controls side) (shown)	1	--	19491GT	CONTACTOR,LIMIT SWITCH.....	2
21A	47657GT	BRACKET,POTHOLE STOPPER,RIGHT..... (battery pack side)	1	--	27643GT	ROLLER ARM-LIMIT SWITCH.....	2
22	48324GT	PLATE,POTHOLE PIVOT W/BEARING..... (includes 1 each item 23)	4	45	47520GT	WASHER,THRUST .75 X 1.25 X .06	
23	39581GT	BEARING,0.75IDX1.00ODX0.50L..... (1.91 x 2.54 x 1.27 cm)	4				



207.2 Pothole Protection Assembly and Counterweights (from SN 35800)

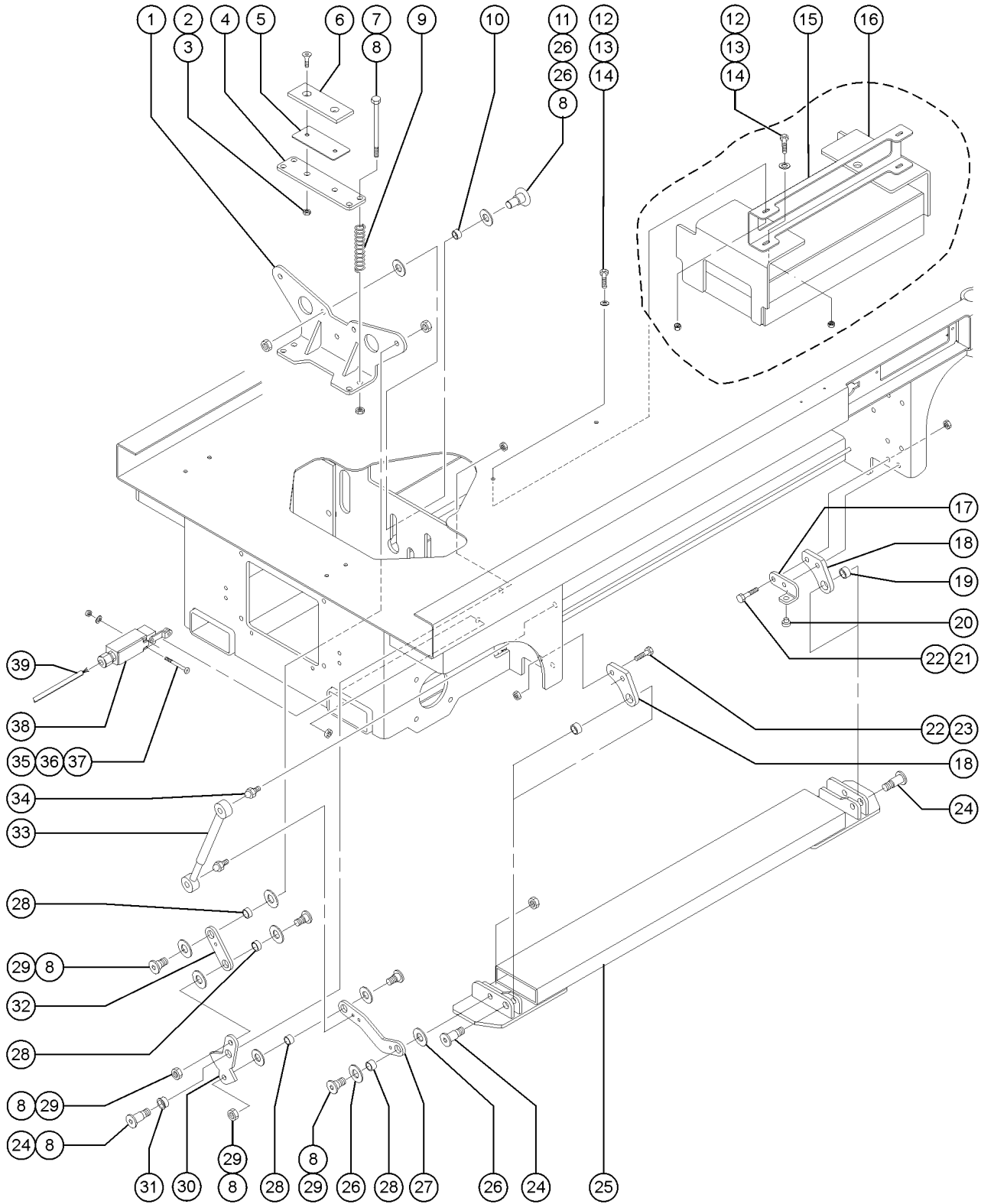

207.2 Pothole Protection Assembly and Counterweights (from SN 35800)

Item	Part No.	Description	Qty.	Item	Part No.	Description	Qty.
--	78093GT	SRV KIT,POTHOLE ACTUATOR, GS46		19	39581GT	BEARING,0.75IDX1.00ODX0.50L.....4 (1.91 x 2.54 x 1.27 cm)	4
--	72877GT	INSTRUCTIONS POTHOLE SRV KIT		20	47230GT	BUMPER,RUBBER.....2	2
--	78093GT	SRV KIT,POTHOLE ACTUATOR, GS46		21	8177GT	SCREW,HHC,1/2-13 X 1.5.....4	4
1	47539GT	WELDMENT,POTHOLE ACTUATOR,46.....1	1	22	6086GT	NUT,LP NYLOCK,1/2-13.....8	8
2	4828GT	NUT,NYLOCK,3/8-16.....6	6	23	51496GT	SCREW,HHC,1/2-13 X 1.375.....4	4
3	64213GT	SCREW,FHS,3/8-16 X 2.25 ZN.....2 (to SN 49199)	2	24	71912GT	BOLT,SHOULDER,5/8-11 X 1.19 LT.....6	6
3A	35463GT	SCREW,FHS,3/8-16 X 1.5.....2 (from SN 49200)	2	25	66716GT	WELDMENT,POTHOLE ARM, 32/46.....2	2
4	47540GT	PLATE,POTHOLE ACTUATOR,46.....2	2	26	78055GT	SPACER, POTHOLE ACTUATOR.....26	26
5	66976GT	PLATE,POTHOLE SPACER, GS46.....1 (to SN 49199) (Quantity listed for this item is approximate. Actual quantity may vary to ensure proper fit.)	1	27	48325GT	PLATE,POTHOLE LINK,LWR.W/BUSH.....2 (includes 2 each item 28)	2
6	47322GT	WEAR PAD,POTHOLE.....1 (15.2 x 6.4 x 1 cm)	1	28	39580GT	BEARING,0.75IDX1.00ODX0.38L.....8 (1.91 x 2.54 x 0.97 cm)	8
7	47593GT	SCREW,HHC,5/8-11 X 10.....4	4	29	47255GT	BOLT,SHORT SHOULDER.....11	11
8	38028GT	NUT,LP NYLOCK,5/8-11.....17	17	30	48326GT	ARM, POTHOLE CRANK, GS32/46.....1 (ground controls side) (shown) (includes item 31)	1
9	47541GT	SPRING,DIE 1.25 X 8.0.....4 (20.3 cm)	4	30A	48359GT	ARM,L POTHOLE CRANK, GS32/46.....1 (battery pack side) (includes 1 each item 31)	1
10	51146GT	SPACER,.75IDX.875ODX.375.....2	2	31	47548GT	BEARING,FL,0.75ID X 1 OD X .49.....2 (1.91 x 2.54 x 0.97 cm)	2
11	66990GT	BOLT, SHOULDER, LARGE FLANGE.....11	11	32	48327GT	PLATE,POTHOLE LINK,UPR.W/BEARI.....2 (includes 2 each item 28)	2
12	6019GT	SCREW,HHC,3/8-16 X 1.25 GRD 5.....4	4	33	39542GT	GAS SHOCK,SCISSORS***.....2	2
13	6097GT	WASHER,FLAT,USS,3/8",Y.....4	4	34	40265GT	BALL STUD,GAS STRUT (38593)***.....4	4
14	4828GT	NUT,NYLOCK,3/8-16.....4	4	35	51063GT	SCREW,PHILLIPS,RHM,10-32 X 1.5.....4	4
15	66452GT	BRACKET, COUNTERWEIGHT, GS3246.....1	1	36	6146GT	WASHER,FLAT,MS,#10,Y.....4	4
16	66453GT	WELDMENT,COUNTERWEIGHT 575 LBS.....1 GS-2646 CE (between fork tubes)	1	37	6178GT	NUT,NYLOCK,10-32.....4	4
16A	66453GT	WELDMENT,COUNTERWEIGHT 575 LBS.....1 GS-3246 (between fork tubes)	1	38	96948GT	SWITCH,LIMIT,W/ROLLER ARM***.....2	2
16B	66430GT	COUNTERWEIGHT, LARGE, GS32.....1 GS-3246 (inside chassis above hydraulic tray)	1	--	19491GT	CONTACTOR,LIMIT SWITCH.....2	2
16C	105015GT	WELDMENT, 3246 RETROFIT GS-3246 CE with Platform Overload option (inside chassis) (from SN 48000 to 59999)		--	27643GT	ROLLER ARM-LIMIT SWITCH.....2	2
17	47656GT	BRACKET,POTHOLE STOPPER,LEFT.....1 (ground controls side) (shown)	1	39	39907GT	WIRE CABLE,18/2 SJO,BULK...86-inches (shown) (ground controls side) (0.281 mm <sup>2</sup> )	
17A	47657GT	BRACKET,POTHOLE STOPPER,RIGHT.....1 (battery pack side)	1	39A	39907GT	WIRE CABLE,18/2 SJO,BULK...62-inches (battery pack side) (0.281 mm <sup>2</sup> )	
18	48324GT	PLATE,POTHOLE PIVOT W/BEARING.....4 (includes 1 each item 20)	4				

208.1 Power Unit Module Installation (to SN 35799)

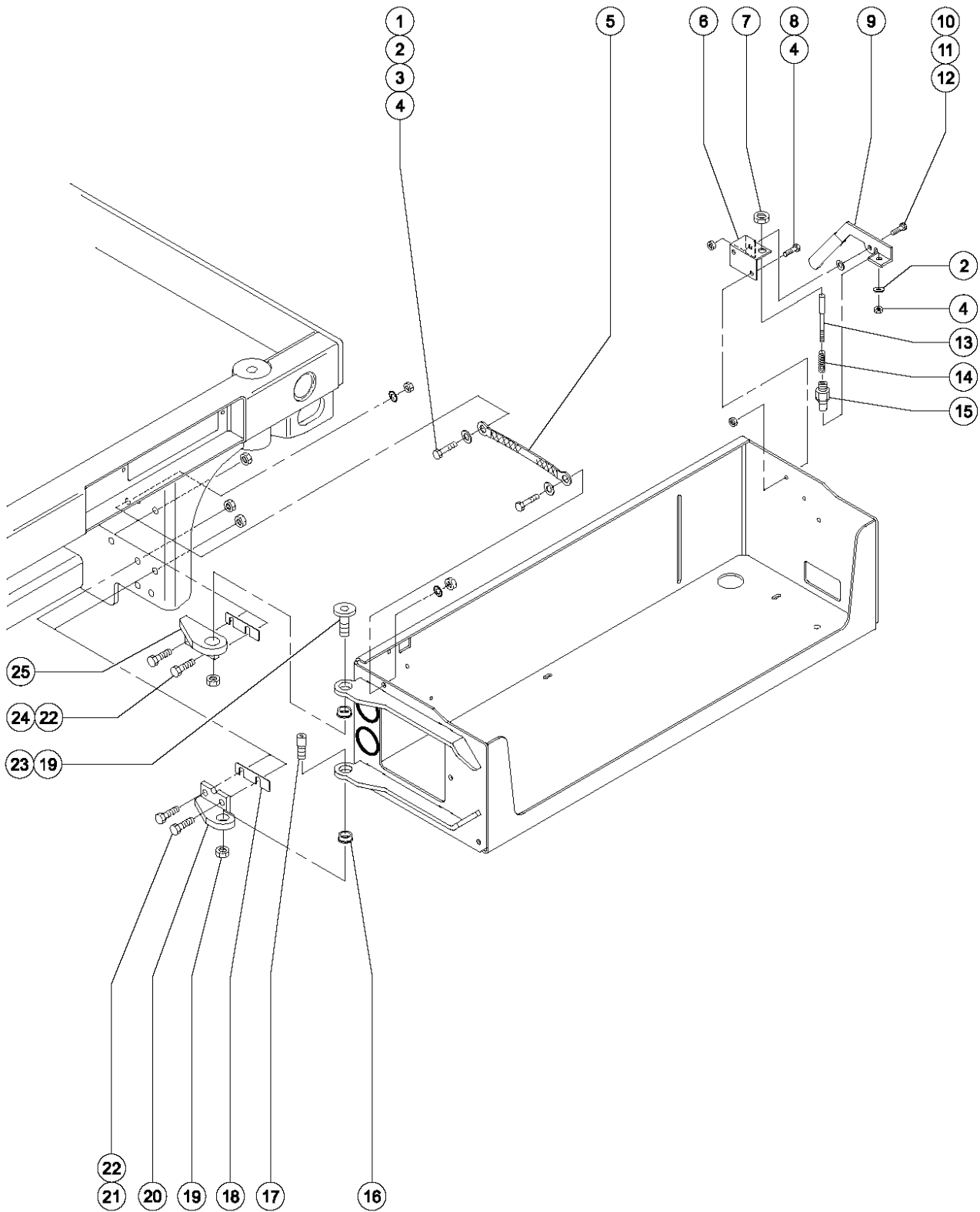

## 208.1 Power Unit Module Installation (to SN 35799)

Item	Part No.	Description	Qty.
1	6019GT	SCREW,HHC,3/8-16 X 1.25 GRD 5.....	2
2	6097GT	WASHER,FLAT,USS,3/8",Y.....	2
3	6700GT	WASHER,STAR,EXTERNAL,,.375.....	2
4	7713GT	NUT, LP NYLOCK, 3/8-16.....	2
5	39532GT	GROUND STRAP.....	1
6	47331GT	BRACKET,LOCK PIN,RIGHT..... <i>(ground controls side)</i>	1
7	8538GT	NUT,LP NYLOCK,3/4-10.....	1
8	33681GT	SCREW,HHC,3/8-16 X .625.....	2
9	46348GT	HANDLE-LOCK,PWR MOD.RIGHT SIDE..... <i>(ground controls side)</i>	1
--	44733GT	HANDLE COVER,PLASTIC.....	1
10	47227GT	SCREW,SHS,5/16-18 X .375.....	1
11	47228GT	WASHER,NYLON,,.406 X.750 X.032.....	1
12	6782GT	NUT,NYLOCK,5/16-18.....	1
13	39470GT	PIN, LOCK.....	1
14	39469GT	SPRING,COMPRESSION.485 X1.75**...1	1
15	41630GT	HOUSING, LOCK PIN.....	1
16	47548GT	BEARING,FL,0.75ID X 1 OD X .49..... <i>(1.91 x 2.54 x 0.97 cm)</i>	2
17	55983GT	PIN-THREADED SHLDR OFFS,5/8-11...1	1
18	47455GT	SPACER,MODULE TRAY,.075 THK..... <i>(1.905 mm) (quantities vary)</i>	2
18A	47342GT	SPACER,MODULE TRAY,.030 THK..... <i>(0.762 mm) (quantities vary)</i>	2
19	38028GT	NUT,LP NYLOCK,5/8-11.....	2
20	47324GT	BRACKET,BOX HINGE,LH-UP/RH-LO...1	1
21	8177GT	SCREW,HHC,1/2-13 X 1.5.....	2
22	6086GT	NUT,LP NYLOCK,1/2-13.....	4
23	47255GT	BOLT,SHORT SHOULDER.....	1
24	10597GT	SCREW,HHC,1/2-13 X 1.25 GR5.....	4
25	47323GT	BRACKET,BOX HINGE,RH-UP/LH-LO...1	1

208.2 Power Unit Module Installation (from SN 35800)

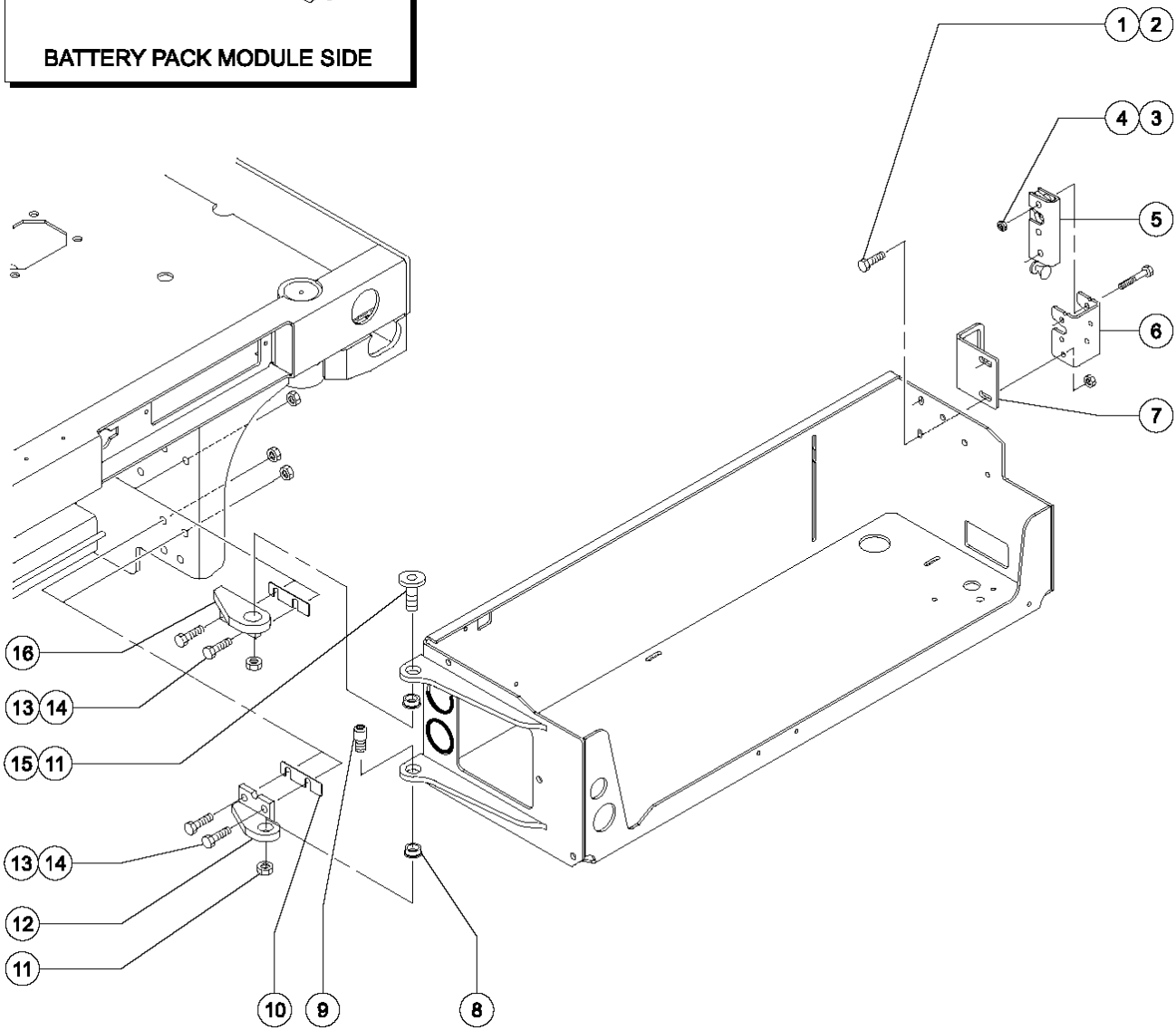
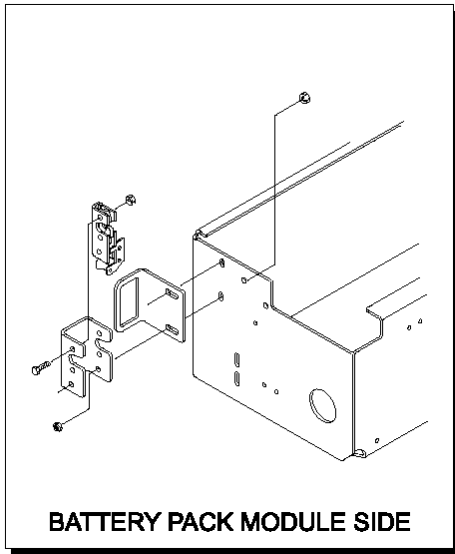



## 208.2 Power Unit Module Installation (from SN 35800)

Item	Part No.	Description	Qty.
--	65971-SGT	HANDLE-ROTATOR LATCH ASSY LS** (battery side)	
--	65972-SGT	HANDLE-ROTATOR LATCH ASSY RS** (ground controls side)	
1	13002GT	SCREW,HHC,5/16-18 X 1 GR5.....	2
2	6782GT	NUT,NYLOCK,5/16-18.....	2
3	13000GT	SCREW,HHC,5/16-18 X 1.25.....	2
4	6002GT	NUT,LP NYLOCK,5/16-18.....	2
5	66901GT	LATCH,ROTARY,W/KNOB,RIGHT..... (ground controls side)	1
5A	66900GT	LATCH,ROTARY, W/KNOB, LEFT..... (battery side)	1
6	65981GT	BRACKET-LATCHMNT,PWR MOD W/DEC.....	1
7	66871GT	FORMING, MOD TRAY HANDLE.....	1
8	39580GT	BEARING,0.75IDX1.00ODX0.38L..... (1.91 x 2.54 x 0.97 cm)	2
9	55983GT	PIN-THREADED SHLDR OFFS,5/8-11...1	1
10	47342GT	SPACER,MODULE TRAY,.030 THK..... (quantities vary)	2
10	47455GT	SPACER,MODULE TRAY,.075 THK..... (quantities vary)	2
11	38028GT	NUT,LP NYLOCK,5/8-11.....	2
12	47324GT	BRACKET,BOX HINGE,LH-UP/RH-LO....1	1
13	8177GT	SCREW,HHC,1/2-13 X 1.5.....	2
14	6086GT	NUT,LP NYLOCK,1/2-13.....	4
15	47255GT	BOLT,SHORT SHOULDER.....	1
16	47323GT	BRACKET,BOX HINGE,RH-UP/LH-LO....1	1

209.1 Power Unit Module Tray (to SN 36044)

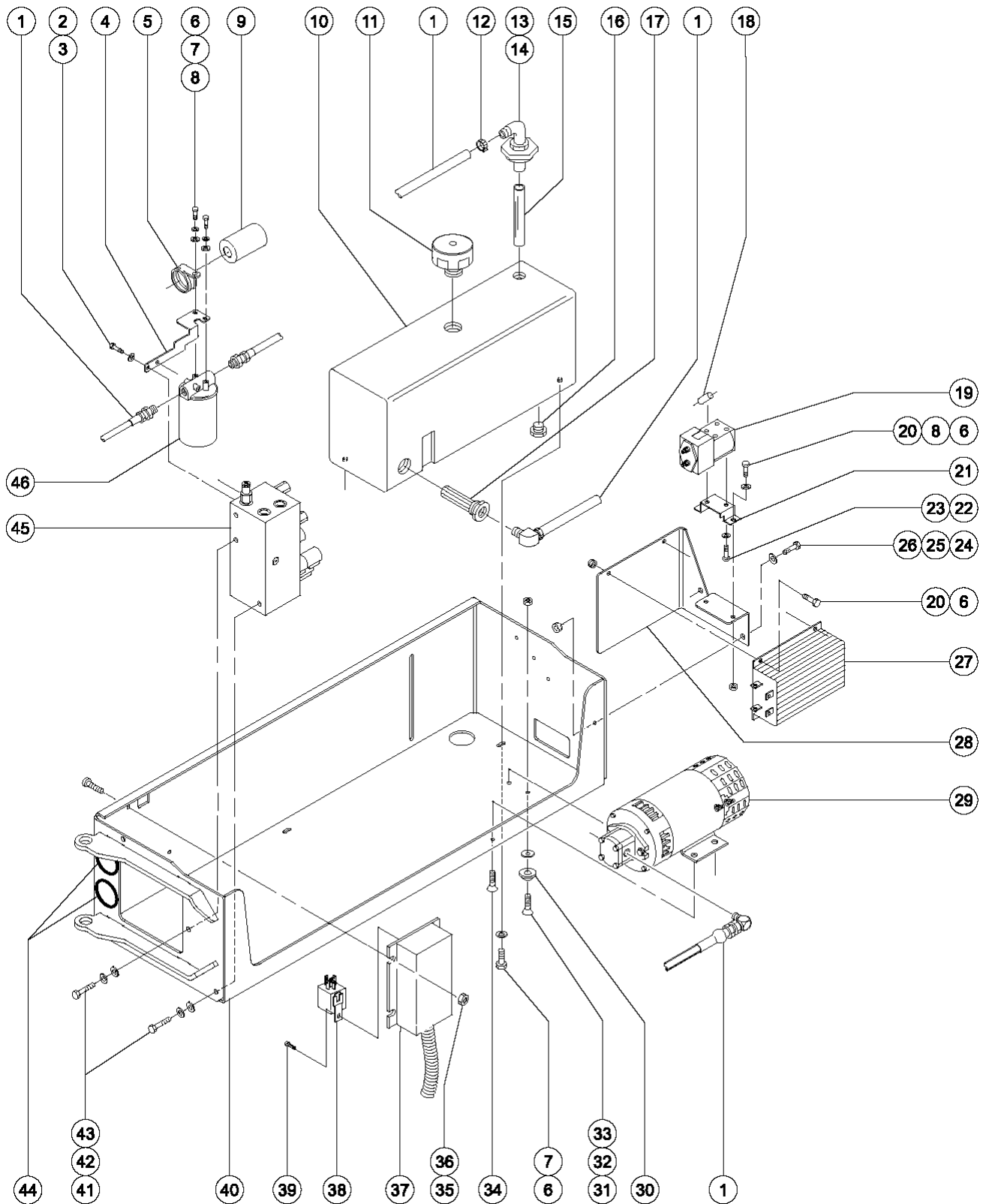

209.1 Power Unit Module Tray (to SN 36044)

Item	Part No.	Description	Qty.	Item	Part No.	Description	Qty.
1		Ref. Hydraulic Hoses and Fittings (refer to Figure 213.1)		22	19871GT	SCREW,HHC,M5 X 6.....	2
2	10107GT	SCREW,HHC,5/16-18 X .75.....	2	23	19872GT	WASHER,LOCK,M5,PLTD.....	2
3	6886GT	WASHER,LOCK,.313.....	2	24	13002GT	SCREW,HHC,5/16-18 X 1 GR5.....	2
4	39438PGT	BRACKET,FILTER MOUNT.....	1	25	5397GT	WASHER,FLAT,USS,5/16",Y.....	2
5	39518GT	CLAMP,2.00,#32 X 3/8,RUB CUSH..... (5.1 cm)	1	26	6782GT	NUT,NYLOCK,5/16-18.....	2
6	8914GT	SCREW, HHC, 1/4-20 X .625.....	8	--	823408GT	MOTOR CONTROLLER, DC,24V,300A motor controllers sold separately only in cases where upgrade kits are N/A or an upgrade kit has been previously installed	
7	6356GT	WASHER, LOCK, .25.....	4	27A	1263633GT	KIT, GS MOTOR CONTROLLER REPL.....	1
8	6638GT	WASHER,FLAT,USS,1/4"Y.....	4	27B	1263634GT	KIT, GS MOTOR CONTROLLER REPL.....	1
9	78585GT	KIT,ACCUM 180 PSI PRECHARGE***..... (12.5 bar) (to SN 46555)	9	27C	1257205GT	KIT,GS46 MOTOR CONTROLLER.....	1
10	55856GT	HYDRAULIC TANK, GS46..... (7.4 gallon, 28 liters) (from SN 26566)	1	27D	219497GT	KIT,CONTACTOR,GS,ALT (if machine does not have a contactor previously installed, 219497 kit is required)	
--	66208GT	KIT,7.43 GAL - COMPLETE..... (28 liters) (from SN 26566)	1	27E	233379GT	KIT, INVERTER JUMPER, GS (if machine has an inverter, 233379 is required in addition to the installation of 219497)	
--	78546GT	BREATHER CAP, HYD. TANK, 1/4 NPT..... (from SN 26566)	1	28	39301GT	BRACKET,CONTROLLER MOUNT.....	1
10A	65736GT	KIT,5 GALLON HYDRAULIC TANK***..... (complete) (19 liters) (to SN 26565) (includes items 11, 13-15 and 17)	1	29		Ref. Hydraulic Power Unit..... (refer to Figure 210.1)	1
--	40832GT	TANK ONLY,HYDRAULIC GS30/32***..... (5 gallon, 19 liters) (to SN 26565)	1	30	47793GT	BUMPER, MODULE TRAY.....	1
11	42019GT	TANK BREATHER,NYLON **..... (to SN 26565)	1	31	19284GT	SCREW,FHS,1/4-20 X .63.....	1
11	66204GT	FILTER CAP (PLUG 1-1/2" NPT HEX (from SN 26566)		32	12906GT	WASHER,FENDER,.25 X 1.25 X.062.....	1
12	42280GT	CLAMP,HOSE,.50..... (1.3 cm)	1	33	6889GT	NUT,LP NYLOCK,1/4-20.....	1
13	39225GT	ELBOW,90ø,.5 MPT X.5BRB PLST.....	1	34	47522GT	SCREW,FHS,1/4-20 X .25 NYLOCK.....	2
14	39223GT	BULKHEAD FITTING,PLASTIC X 8**.....	1	35	6178GT	NUT,NYLOCK,10-32.....	2
15	39226GT	NIPPLE,PLASTIC .5 NPT X 6"..... (15.2 cm)	1	36	6147GT	SCREW,RHM,10-32 X 1.....	2
16	39227GT	PLUG,HEX HEAD-8 PLASTIC.....	1	--	39520GT	RECEPTACLE,FEMALE,36 CONTACT... (to SN 17407)	1
17	55616GT	STRAINER ASSEMBLY.....	1	--	39521GT	RECEPTACLE,ANTI-BACKOUT..... (to SN 17407)	1
18	39533GT	CAPACITOR,1.0 MFD..... (to SN 6899) (includes wire connectors)	1	--	39522GT	WIRE SEAL,GRAY..... (to SN 17407)	1
19	74267GT	CONTACTOR,DRIVE,24V,180A***..... (to SN 6899)	1	--	39523GT	CAVITY PLUG,GRAY..... (to SN 17407)	1
--	74468GT	SPRING, RETURN (FOR 74267)..... (to SN 6899)	1	--	39673GT	CONTACT,14-20GA..... (to SN 17407)	1
--	74469GT	FIXED CONTACT (FOR 74267)..... (to SN 6899)	1	--	78313GT	SERVICE KIT, BOM PLUG..... (to SN 17407)	1
--	74470GT	MOVING CONTACT (FOR PN 74267)..... (to SN 6899)	1	37A	105295GT	KIT,GEN1 TO GEN5 CONTRL SYS***..... (models with platform PCB Rev A or Rev B) (to SN 17407)	1
20	6091GT	NUT,NYLOCK,1/4-20.....	4	37B	97055GT	ECM,SLAB,SERVICE*** (models with platform PCB Rev C) (to SN 17407)	
21	19815GT	BRACKET, RELAY MOUNTING..... (to SN 6899)	1				



209.1 Power Unit Module Tray (to SN 36044)  
(continued)

Item	Part No.	Description	Qty.
37C	78725GT	ECU,SLAB,GEN4*** .....1 (from SN 17408 to 59999)	
--	39520GT	RECEPTACLE,FEMALE,36 CONTACT...1 (from SN 17408 to 59999)	
--	39521GT	RECEPTACLE,ANTI-BACKOUT.....1 (from SN 17408 to 59999)	
--	39522GT	WIRE SEAL,GRAY.....1 (from SN 17408 to 59999)	
--	39523GT	CAVITY PLUG,GRAY.....1 (from SN 17408 to 59999)	
--	39673GT	CONTACT,14-20GA.....1 (from SN 17408 to 59999)	
--	78313GT	SERVICE KIT, BOM PLUG.....1 (from SN 17408 to 59999)	
38	56302GT	RELAY,24VDC,40/30A,SEALED*** .....1	
39	47363GT	SCREW,RHM,8-32 X .50.....1	
40	46332GT	MODULE TRAY ASSY-HYD PWR UNIT.....1 (includes items 30, 31, 32 and 33 and 44) (bearings shown in 208.1)	
41	8255GT	SCREW, HHC, 3/8-16 X .75.....2	
42	6021GT	WASHER, LOCK, .375.....2	
43	6700GT	WASHER,STAR,EXTERNAL,.375.....2	
44	47232GT	GROMMET,RUBBER 2 X 2.75.....2 (5.1 x 7 cm)	
45		Ref Function Manifold.....1 (refer to Figure 211.1)	
46	78622GT	FILTER ASSY,SAE8,10 MIC,PAPR**.....1	
--	44207GT	FILTER ELEMENT,BETA(10)=200.....1 (fiberglass, optional)	
--	44788GT	FILTER ELEMENT,10MICRON,PAPER*.....1 (paper, standard)	

209.1 Power Unit Module Tray (to SN 36044)  
(continued)

*This Page Intentionally Left Blank*

209.2 Power Unit Module Tray (from SN 36045)

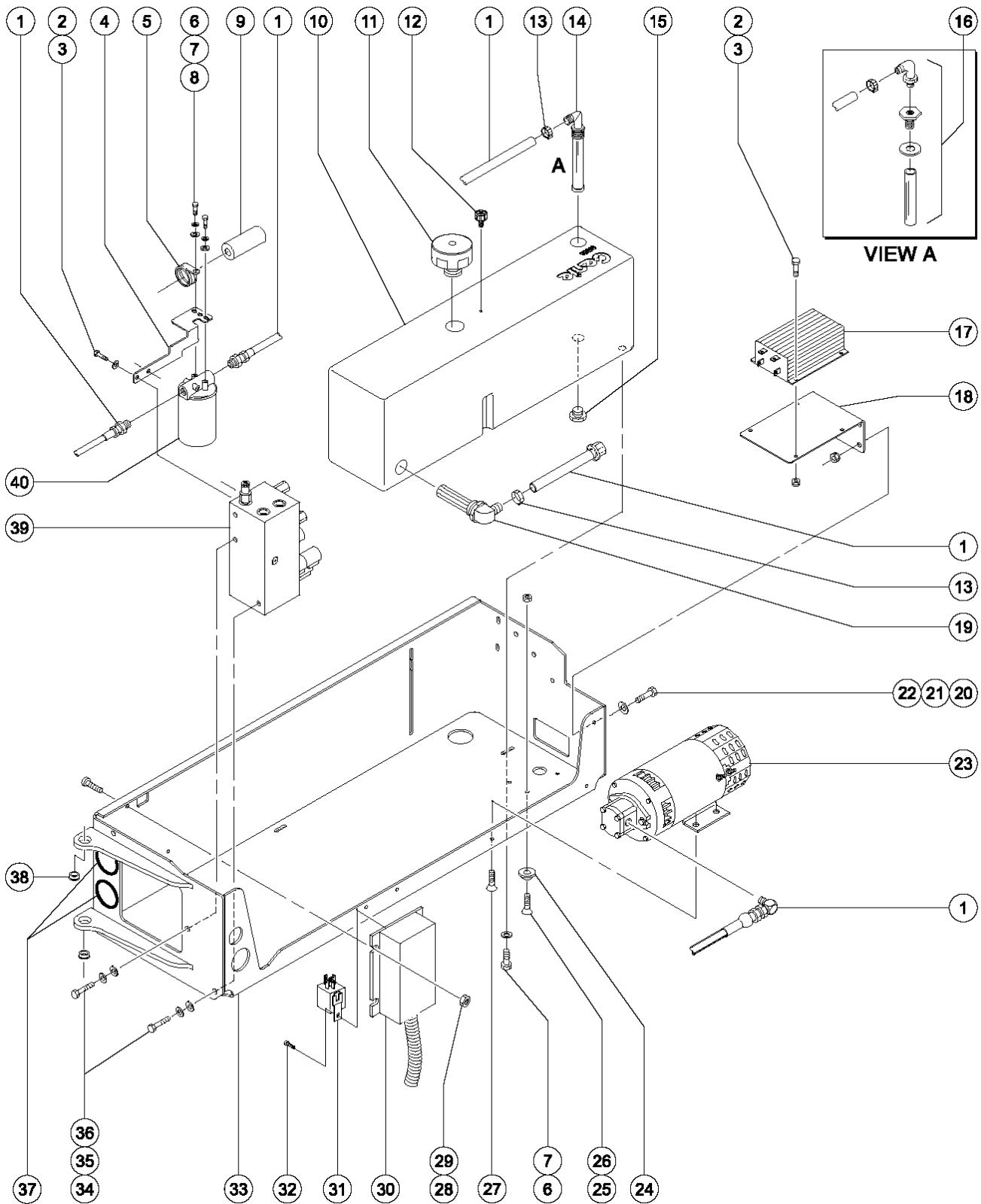

209.2 Power Unit Module Tray (from SN 36045)

Item	Part No.	Description	Qty.	Item	Part No.	Description	Qty.
1		Ref. Hydraulic Hoses and Fittings <i>(refer to Figure 213.2)</i>		24	47793GT	BUMPER, MODULE TRAY.....	1
2	8255GT	SCREW, HHC, 3/8-16 X .75.....	2	25	19284GT	SCREW,FHS,1/4-20 X .63.....	1
3	6021GT	WASHER, LOCK, .375.....	2	26	6889GT	NUT,LP NYLOCK,1/4-20.....	1
4	39438PGT	BRACKET,FILTER MOUNT.....	1	27	47522GT	SCREW,FHS,1/4-20 X .25 NYLOCK.....	2
5	32339GT	CLAMP,1.75,#28 X 3/8,RUB CUSH..... <i>(from SN 46557)</i>	1	28	6178GT	NUT,NYLOCK,10-32.....	2
5A	39518GT	CLAMP,2.00,#32 X 3/8,RUB CUSH..... <i>(to SN 46556)</i>	1	29	6147GT	SCREW,RHM,10-32 X 1.....	2
6	6888GT	SCREW,HHC,1/4-20 X 1.....	2	30	78725GT	ECU,SLAB,GEN4***..... <i>(from SN 17408 to 59999)</i>	1
7	6356GT	WASHER, LOCK, .25.....	2	--	39520GT	RECEPTACLE,FEMALE,36 CONTACT... <i>(from SN 17408 to 59999)</i>	1
8	6638GT	WASHER,FLAT,USS,1/4"Y.....	2	--	39521GT	RECEPTACLE,ANTI-BACKOUT..... <i>(from SN 17408 to 59999)</i>	1
9	78422GT	ACCUMULATOR,180 PSI PRECHARGE*..... <i>(from SN 46557) (12.5 bar)</i>	1	--	39673GT	CONTACT,14-20GA..... <i>(from SN 17408 to 59999)</i>	1
9A	78585GT	KIT,ACCUM 180 PSI PRECHARGE***..... <i>(to SN 46556) (includes clamp)</i>	1	--	78313GT	SERVICE KIT, BOM PLUG..... <i>(from SN 17408 to 59999)</i>	1
10	66208GT	KIT,7.43 GAL - COMPLETE..... <i>(28 liters) (includes items 1, 12, 13 and 16)</i>	1	31	78098GT	RELAY,24VDC,40/30A,SLD W/BRKT*..... <i>(to SN 49486)</i>	1
10A	55856GT	HYDRAULIC TANK, GS46..... <i>(7.4 gallon, 28 liters)</i>	1	31A	56302GT	RELAY,24VDC,40/30A,SEALED***..... <i>(from SN 49487)</i>	1
11	66204GT	FILTER CAP (PLUG 1-1/2" NPT HEX.....)	1	32	47363GT	SCREW,RHM,8-32 X .50.....	1
12	78546GT	BREATHER CAP, HYD. TANK, 1/4 NPT.....	1	33	46332GT	MODULE TRAY ASSY-HYD PWR UNIT..... <i>(includes items 24, 37 and 38) (bearings shown in 208.2)</i>	1
13	19273GT	CLAMP,HOSE,,.75 **..... <i>(2 cm)</i>	2	--	12906GT	WASHER,FENDER,.25 X 1.25 X.062.....	1
14	39225GT	ELBOW,90ø,.5 MPT X.5BRB PLST.....	1	--	8514GT	SCREW,FHS,1/4-20 X .75.....	1
15	39227GT	PLUG,HEX HEAD-8 PLASTIC.....	1	34	8255GT	SCREW, HHC, 3/8-16 X .75.....	2
16	65318GT	FITTING KIT-HYDRAULIC TANK.....	1	35	6021GT	WASHER, LOCK, .375.....	2
17A	1263634GT	KIT, GS MOTOR CONTROLLER REPL..... <i>(replaces 218236)</i>	1	36	6700GT	WASHER,STAR,EXTERNAL,,.375.....	2
--	823408GT	MOTOR CONTROLLER, DC,24V,300A <i>motor controllers sold separately only in cases where upgrade kits are N/A or an upgrade kit has been previously installed</i>		37	47232GT	GROMMET,RUBBER 2 X 2.75..... <i>(5.1 x 7 cm)</i>	2
17B	219497GT	KIT,CONTACTOR,GS,ALT <i>(if machine does not have a contactor previously installed, 219497 kit is required)</i>		38	39580GT	BEARING,0.75IDX1.00ODX0.38L.....	2
17C	233379GT	KIT, INVERTER JUMPER, GS <i>(if machine has an inverter, 233379 is required in addition to the installation of 219497)</i>		39		Ref. Function Manifold..... <i>(refer to Figure 211.2 or 211.3)</i>	1
18	55789GT	BRACKET, CONTROLLER MOUNT.....	1	40	78698GT	SERVICE KIT,FILTER,2032/46.....	1
19	55616GT	STRAINER ASSEMBLY.....	1	--	44207GT	FILTER ELEMENT,BETA(10)=200..... <i>(fiberglass, optional)</i>	1
20	10107GT	SCREW,HHC,5/16-18 X .75.....	4	--	44788GT	FILTER ELEMENT,10MICRON,PAPER*..... <i>(paper, standard)</i>	1
21	5397GT	WASHER,FLAT,USS,5/16",Y.....	4	--	78622GT	FILTER ASSY,SAE8,10 MIC,PAPR**.....	1
22	6782GT	NUT,NYLOCK,5/16-18.....	4				
23		Ref. Hydraulic Power Unit..... <i>(refer to Figure 210.1)</i>	4				



210.1 Hydraulic Power Unit

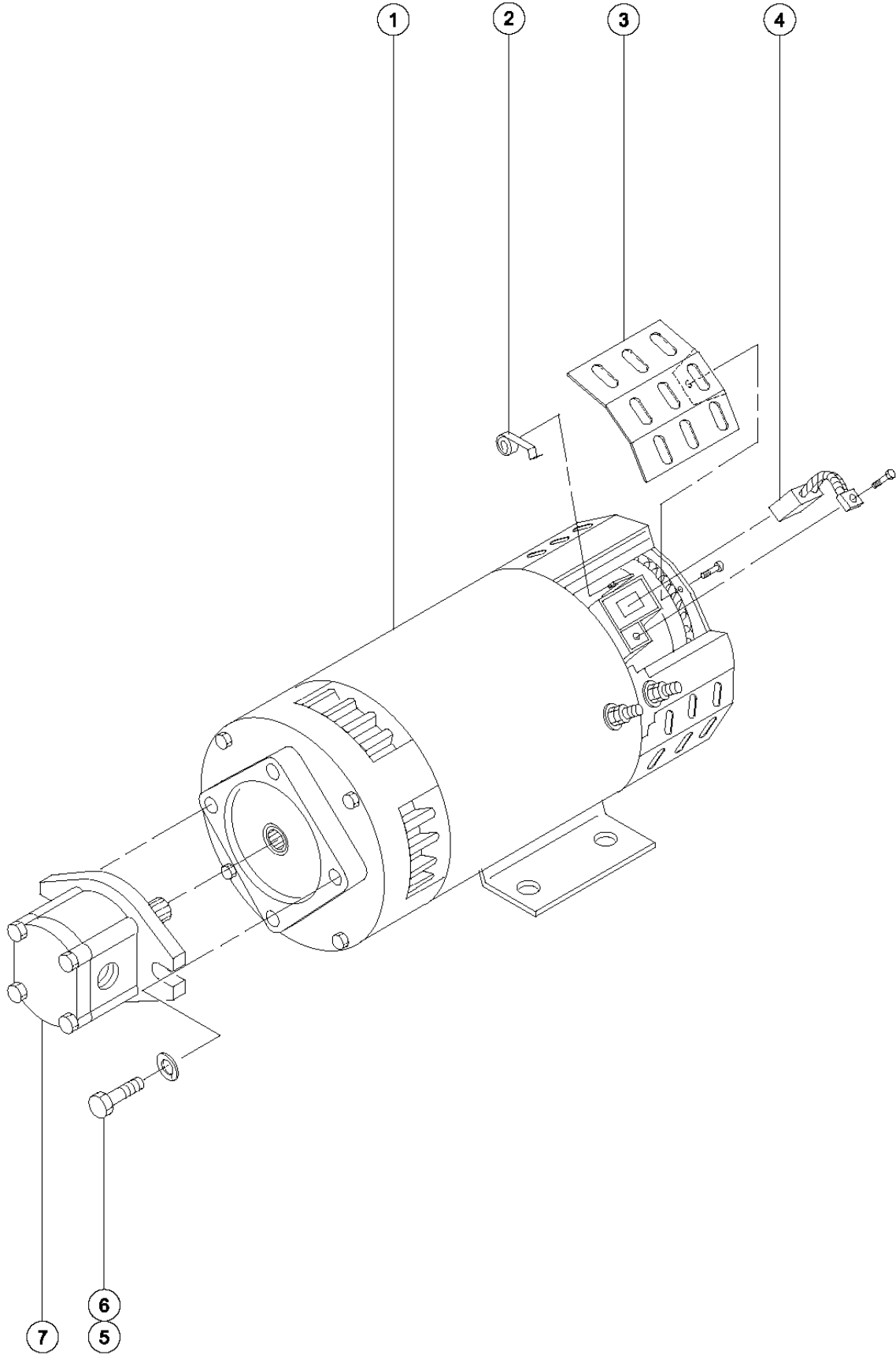



210.1 Hydraulic Power Unit

Item	Part No.	Description	Qty.
1	40844GT	MOTOR,ELECTRIC,24VDC 4.5HP.....1 <i>(includes seal kit and items 1, 3 and 4) units before SN 36045 requier bracket 105390</i>	1
--	105390GT	BRACKET, CONTROLLER MOUNT,SP.....1 <i>(to SN 36044) not shown, not included, sold separately</i>	1
--	43685GT	SEAL KIT,LIFT PUMP,BARNES**.....1	1
--	44777GT	BEARING,MOTOR.....1	1
--	44778GT	BEARING,MOTOR,36843,BRUSH END*.....1	1
2	44750GT	SPRING-BRUSH,40844, SCISSORS....4	4
3	44752GT	COVER-BRUSH INSPEC.40844,SCISS.....4	4
4	44751GT	BRUSH,PWR UNIT (40844)**.....4	4
5	55921GT	SCREW,SHC,3/8-24 X 1.25".....2	2
6	6021GT	WASHER, LOCK, .375.....2	2
7	96193GT	PUMP,4CC GEAR,CCW*** .....1 <i>(Bosch)</i>	1
7A	66206GT	PUMP KIT,BOSCH,GS30*** <i>(to SN 16988) (Barnes pump replacements only)</i>	
7B	43685GT	SEAL KIT,LIFT PUMP,BARNES** <i>(to SN 16988) (Barnes pump replacements only)</i>	
7C	85197GT	SEAL KIT,BOSCH PUMP*** <i>for 96193</i>	

211.1 Function Manifold (to SN 36044)

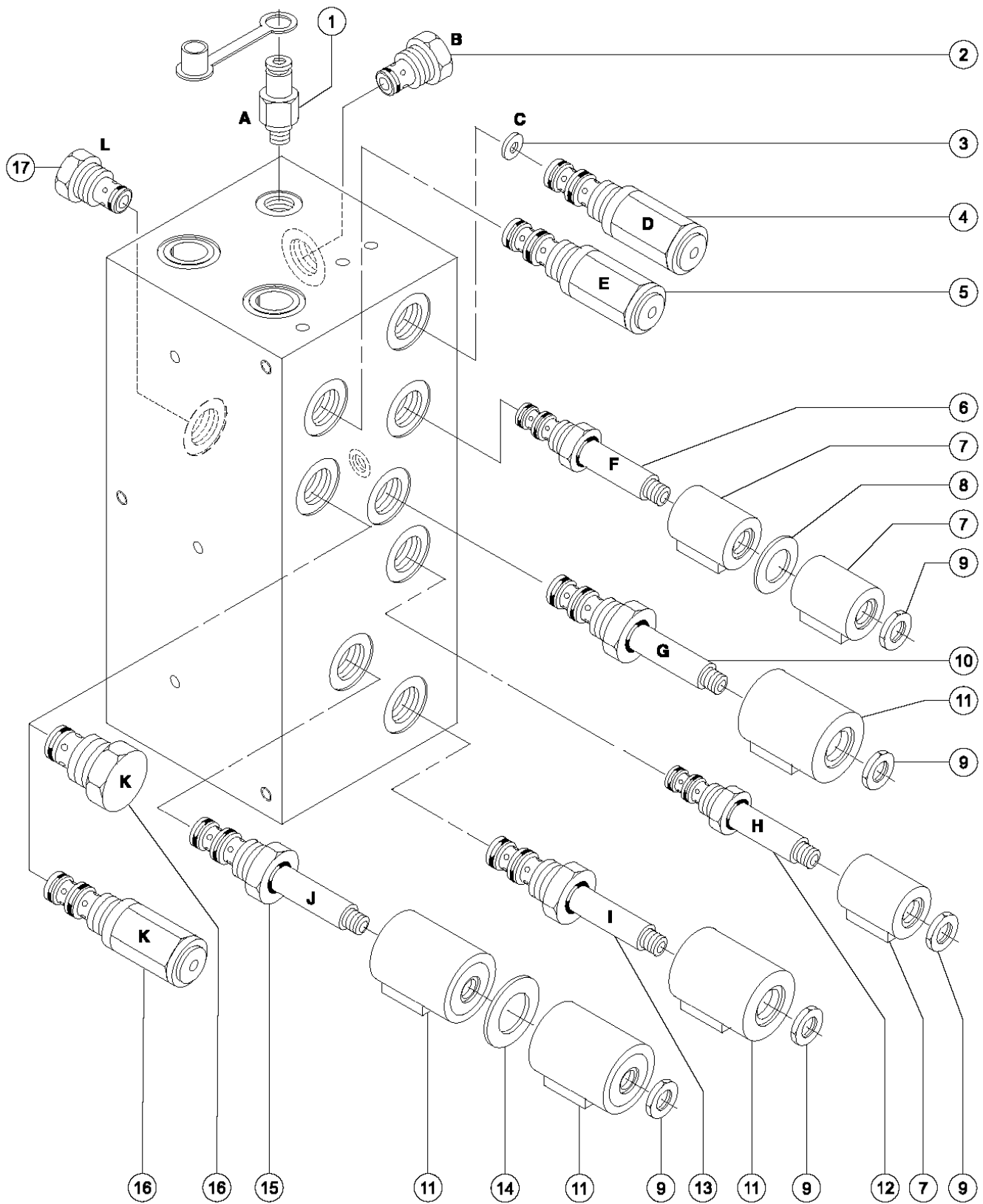

211.1 Function Manifold (to SN 36044)

Item	Part No.	Description	Qty.	Item	Part No.	Description	Qty.
A		Diagnostic nipple <i>Testing</i>		9	44174GT	NUT-COIL SHORT.....	5
B		Flow regulator valve <i>Steer circuit</i>		10	44169GT	VALVE-SOLENOID, 2POS 4 WAY.....	1
C		Orfice <i>Steer circuit</i>		--	44230GT	SEAL KIT-P.N.44169,44172,44171.....	1
D		Relief valve <i>Steering relief</i>		11	44176GT	COIL,20V W/DIODE,#10 (SCI).....	4 <i>(to SN 6843)</i>
E		Relief valve <i>Sistem relief</i>		11A	52595GT	COIL,20V DS W/DIODE,#10 SCISRS.....	4 <i>(from SN 6844)</i>
F		Solenoid valve <i>Steer left/right</i>		12	44170GT	VALVE-SOLENOID N.O.(SCISSORS)*.....	1
G		Solenoid valve <i>Platform up</i>		--	44228GT	SEAL KIT, VALVE.....	1
H		Solenoid valve <i>Brake circuit</i>		13	44171GT	VALVE-SOLENOID,2POS 4WAY**.....	1
I		Solenoid valve <i>Drive speed</i>		--	44230GT	SEAL KIT-P.N.44169,44172,44171.....	1
J		Solenoid valve <i>Forward/reverse</i>		14	44175GT	SPACER-DUAL COIL,#10, SCISSORS...1	
K		Check Valve <i>Brake circuit</i>		15	105457GT	KIT,DYN BRAKING VALVE,MINI.....	1
L		Check Valve <i>Steer circuit</i>		--	44230GT	SEAL KIT-P.N.44169,44172,44171.....	1
--		<i>(Use this list to identify the function of the components illustrated in the drawing)</i>		16	44178GT	VALVE,CHECK,5 PSI**.....	1 <i>(0.3 bar) (to SN 17481)</i>
--	51679GT	MANIFOLD MAIN VALVE,W/20 VDC* <i>(complete) (does not include item 17)</i>		--	44224GT	SEAL KIT, VALVE.....	1 <i>(to SN 17481)</i>
1	48997GT	NIPPLE,DIAGNOSTIC,#4.....	1	16A	58998GT	VALVE-RELIEF,130 PSI.....	1 <i>(9 bar) (from SN 17482)</i>
--	20224GT	DIAGNOSTIC FEMALE Q-DSCNT.....	1 <i>(Parker PN PD242)</i>	--	44227GT	SEAL KIT, VALVE.....	1 <i>(from SN 17482)</i>
--	48880GT	CAP,DIAGNOSTIC NIPPLE.....	1	17	48659GT	VALVE,CHECK***.....	1
2	62082GT	VALVE-FLOW REGULATOR 0.75 GPM.....	1 <i>(2.8 L/min)</i>	--	44227GT	SEAL KIT, VALVE.....	1
--	44225GT	SEAL KIT, VALVE.....	1				
3	46288GT	ORIFICE DISC,.040".....	1 <i>(1.02 mm)</i>				
4	44166GT	VALVE,RELIEF,1000PSI(SCISSORS).....	1 <i>(69 bar)</i>				
--	44227GT	SEAL KIT, VALVE.....	1				
5	44167GT	VALVE,RELIEF,3500PSI(SCISRS)**.....	1 <i>(241.3 bar)</i>				
--	44226GT	SEAL KIT-FOR P.N.44167.....	1				
6	44168GT	VALVE,SOLENOID,3POS 4WAY.....	1				
--	44229GT	SEAL KIT, VALVE.....	1				
7	39347GT	COIL,20V W/DIODE,#8 (SCI)***.....	3 <i>(from SN 6843 to 36044) (single spade coil)</i>				
8	44236GT	SPACER-DUAL COIL,#8***.....	1				



211.2 Function Manifold (from 36045)

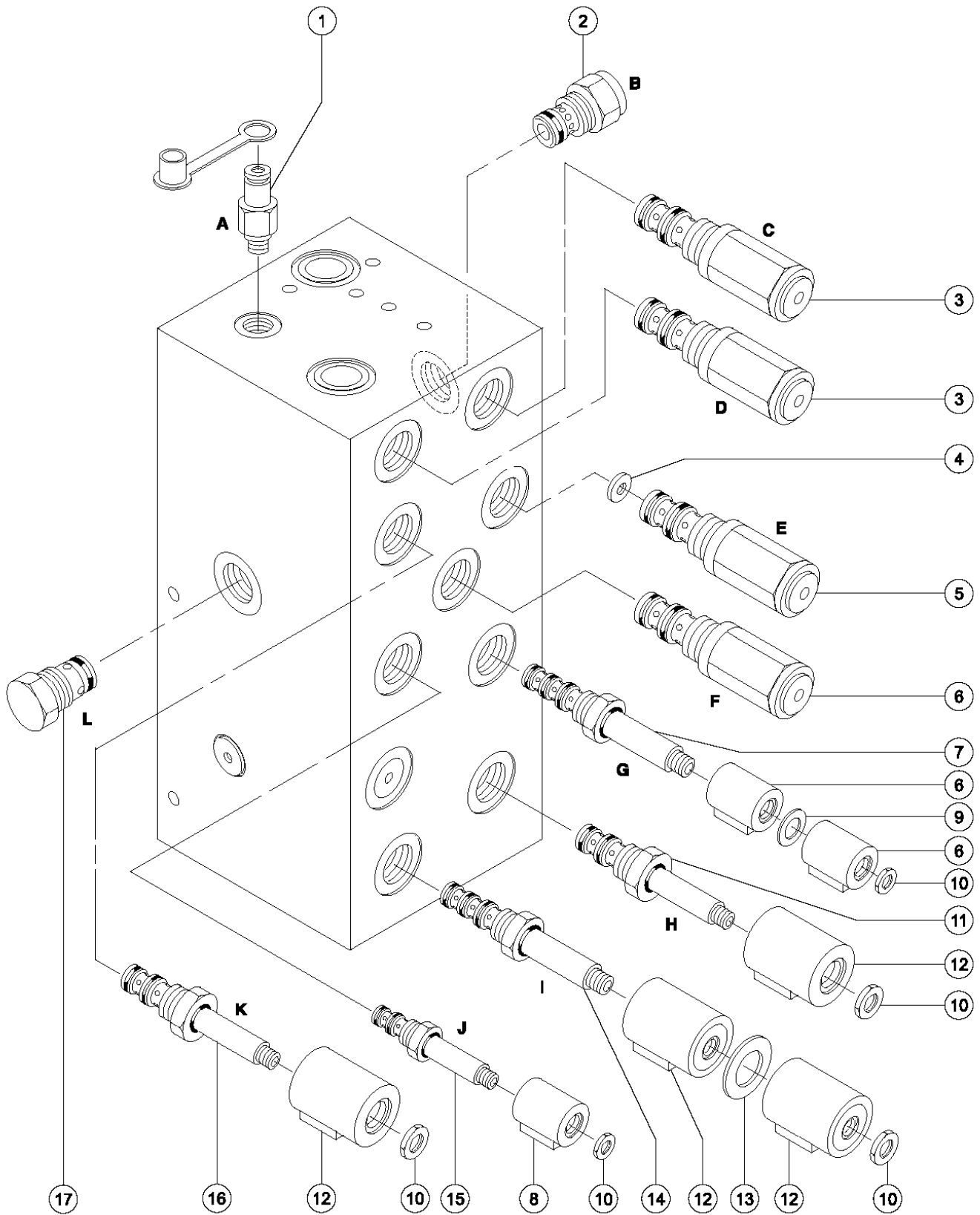

211.2 Function Manifold (from 36045)

Item	Part No.	Description	Qty.	Item	Part No.	Description	Qty.
A		Diagnostic nipple <i>Testing</i>		9	44236GT	SPACER-DUAL COIL,#8***.....	1
B		Flow regulator valve <i>Steer circuit</i>		10	44174GT	NUT-COIL SHORT.....	2
C		Orifice <i>Platform up</i>		11	44171GT	VALVE-SOLENOID,2POS 4WAY**.....	1
D		Relief valve <i>System relief</i>		--	44230GT	SEAL KIT-P.N.44169,44172,44171.....	1
E		Relief valve <i>Steering relief</i>		12	52595GT	COIL,20V DS W/DIODE,#10 SCISR.....	4
F		Solenoid valve <i>Brake relief</i>		13	44175GT	SPACER-DUAL COIL,#10, SCISSORS...	1
G		Solenoid valve <i>Steer left/right</i>		14	105457GT	KIT,DYN BRAKING VALVE,MINI.....	1
H		Solenoid valve <i>Drive speed</i>		--	44230GT	SEAL KIT-P.N.44169,44172,44171.....	1
I		Solenoid valve <i>Forward/reverse</i>		15	44170GT	VALVE-SOLENOID N.O.(SCISSORS)*....	1
J		Flow regulator valve <i>Brake circuit</i>		--	44228GT	SEAL KIT, VALVE.....	1
K		Check Valve <i>Platform up</i>		16	44169GT	VALVE-SOLENOID, 2POS 4 WAY.....	1
L		Check Valve <i>Steer circuit</i>		--	44230GT	SEAL KIT-P.N.44169,44172,44171.....	1
--		<i>(Use this list to identify the function of the components illustrated in the drawing)</i>					
--	66772GT	STD MANIFOLD MAIN,GS32/46 <i>(complete) (does not include item 1)</i>		17	46216GT	VALVE,CHECK,IWP-S/CWP PWR ASSI.....	1
1	48997GT	NIPPLE,DIAGNOSTIC,#4.....	1			<i>(0.3 bar)</i>	
--	20224GT	DIAGNOSTIC FEMALE Q-DSCNT.....	1	--	44227GT	SEAL KIT, VALVE.....	1
--	48880GT	CAP,DIAGNOSTIC NIPPLE.....	1				
2	62082GT	VALVE-FLOW REGULATOR 0.75 GPM.....	1				
		<i>(2.8 L/min)</i>					
--	44225GT	SEAL KIT, VALVE.....	1				
3	65962GT	VALVE-RELIEF, 3700 PSI #8**.....	2				
		<i>(255 bar)</i>					
--	44226GT	SEAL KIT-FOR P.N.44167.....	2				
4	46288GT	ORIFICE DISC,.040".....	1				
		<i>(1 mm)</i>					
5	65184GT	VALVE-RELIEF,1500 PSI, RV2.....	1				
		<i>(103.4 bar)</i>					
--	44227GT	SEAL KIT, VALVE.....	1				
6	58998GT	VALVE-RELIEF,130 PSI.....	1				
		<i>(9 bar)</i>					
--	44227GT	SEAL KIT, VALVE.....	1				
7	44168GT	VALVE,SOLENOID,3POS 4WAY.....	1				
--	44229GT	SEAL KIT, VALVE.....	1				
8	52594GT	COIL,20V DS W/DIODE.....	3				

211.3 Function Manifold - Models with Traction Control

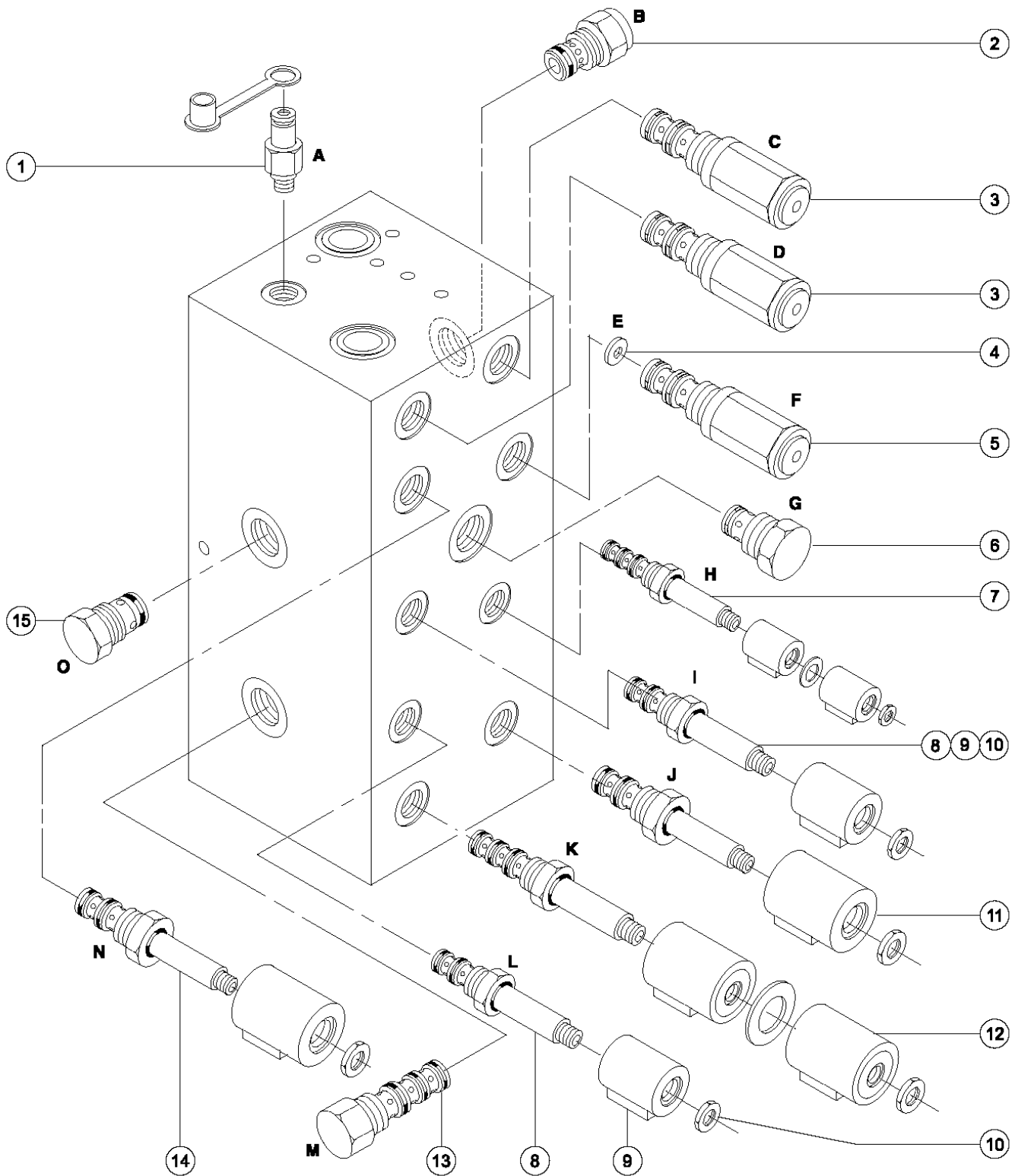

211.3 Function Manifold - Models with Traction Control

Item	Part No.	Description	Qty.	Item	Part No.	Description	Qty.
A		Diagnostic nipple <i>Testing</i>		--	44227GT	SEAL KIT, VALVE.....	1
B		Flow regulator valve <i>Steer circuit</i>		7	44168GT	VALVE,SOLENOID,3POS 4WAY.....	1
C		Orifice <i>Platform up</i>		--	44229GT	SEAL KIT, VALVE.....	1
D		Relief valve <i>System relief</i>		8	44170GT	VALVE-SOLENOID N.O.(SCISSORS)*.....	1
E		Relief valve <i>Steer circuit</i>		--	44228GT	SEAL KIT, VALVE.....	1
F		Solenoid valve <i>Steer relief</i>		9	52594GT	COIL,20V DS W/DIODE.....	1
G		Solenoid valve <i>Brake circuit</i>		10	44174GT	NUT-COIL SHORT.....	1
H		Solenoid valve <i>Steer left/right</i>		11	44171GT	VALVE-SOLENOID,2POS 4WAY**.....	1
I		Relief valve <i>Brake circuit</i>		--	44230GT	SEAL KIT-P.N.44169,44172,44171.....	1
J		Solenoid valve <i>Drive speed</i>		12	105457GT	KIT,DYN BRAKING VALVE,MINI.....	1
K		Solenoid valve <i>Forward/reverse</i>		--	44230GT	SEAL KIT-P.N.44169,44172,44171.....	1
L		Check Valve <i>High speed</i>		13	78112GT	VALVE,FLOW DIVIDER/COMBINER.....	1
M		Flow divider valve <i>Drive split limit</i>		--	44227GT	SEAL KIT, VALVE.....	1
N		Solenoid valve <i>Platform up</i>		14	44169GT	VALVE-SOLENOID, 2POS 4 WAY.....	1
O		Check Valve <i>Steer circuit</i>		--	44230GT	SEAL KIT-P.N.44169,44172,44171.....	1
--		<i>(use this list to identify the function of the components illustrated in the drawing)</i>		15	46216GT	VALVE,CHECK,IWP-S/CWP PWR ASSI.....	1
--	66772GT	STD MANIFOLD MAIN,GS32/46				<i>(0.7 bar)</i>	
1	48997GT	NIPPLE,DIAGNOSTIC,#4.....	1	--	44228GT	SEAL KIT, VALVE.....	1
--	20224GT	DIAGNOSTIC FEMALE Q-DSCNT.....	1				
--	48880GT	CAP,DIAGNOSTIC NIPPLE.....	1				
2	62082GT	VALVE-FLOW REGULATOR 0.75 GPM.....	1				
		<i>(2.8 L/min)</i>					
--	44225GT	SEAL KIT, VALVE.....	1				
3	65962GT	VALVE-RELIEF, 3700 PSI #8**.....	2				
		<i>(255 bar)</i>					
--	44226GT	SEAL KIT-FOR P.N.44167.....	2				
4	46288GT	ORIFICE DISC,.040".....	1				
		<i>(1 mm)</i>					
5	65184GT	VALVE-RELIEF,1500 PSI, RV2.....	1				
		<i>(103.4 bar)</i>					
--	44227GT	SEAL KIT, VALVE.....	1				
6	48659GT	VALVE,CHECK***.....	1				
		<i>(2 bar)</i>					



212.1 Ground Controls (to SN 28695)

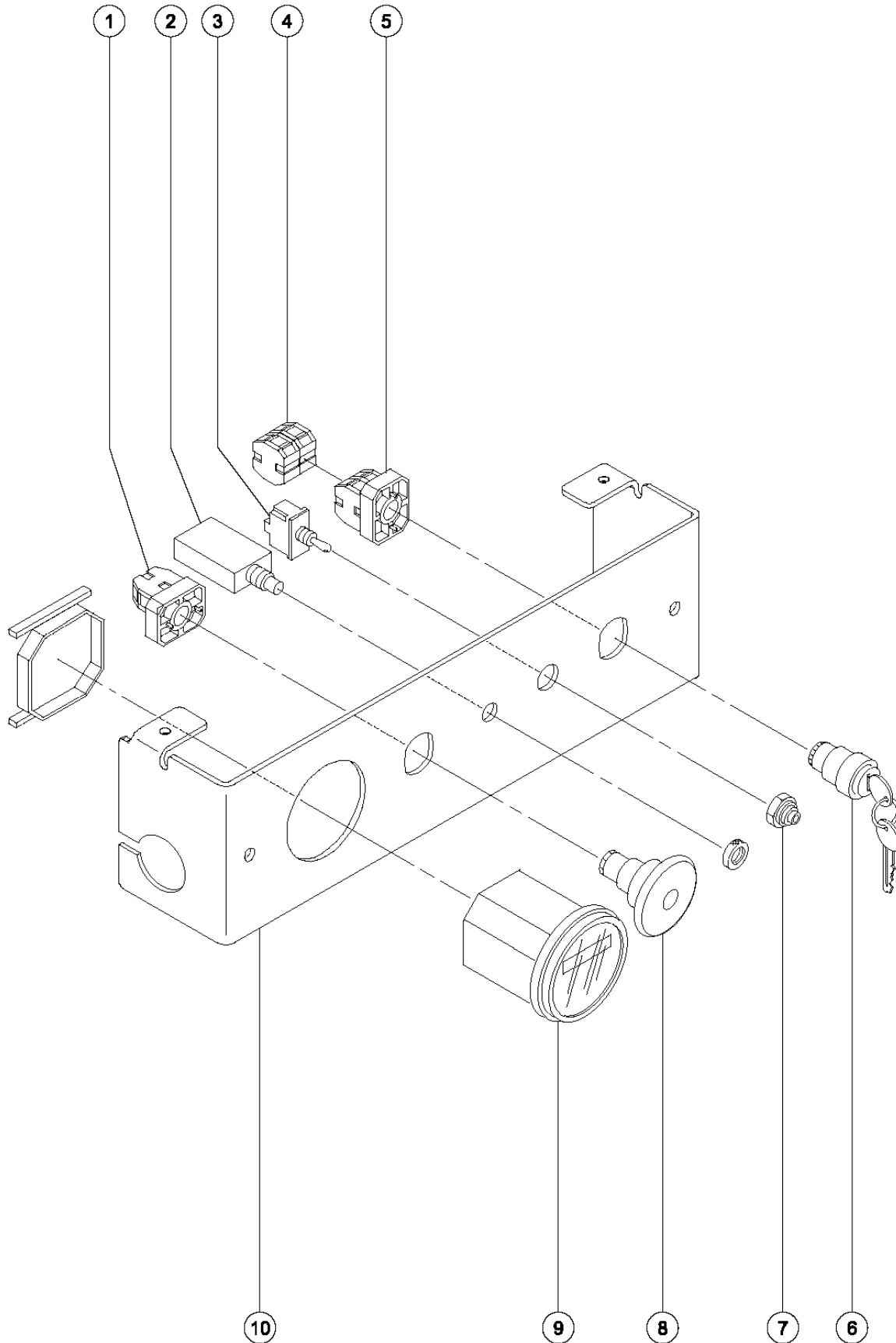



## 212.1 Ground Controls (to SN 28695)

Item	Part No.	Description	Qty.
1		Ref. Base, Push Button.....1 <i>(refer to item 8)</i>	1
2	96452GT	CIRCUIT BREAKER,7.0 AMP***.....1 <i>(includes mounting fasteners)</i>	1
3	80220GT	SWITCH,TOGGLE,SPDT***.....1	1
4		Ref. Contact.....2 <i>(refer to item 6)</i>	2
5		Ref. Base, Push Button.....1 <i>(refer to item 6)</i>	1
6	96011GT	KIT, KEYSWITCH***.....1 <i>(this is an update kit; the original key switch is no longer available from the supplier. Please note, if this kit has already been installed on the unit, refer to the part numbers listed below)</i>	1
--	21982GT	KEY,SINGLE***	
--	37947GT	KEYS,10 PACK***	
--	83093GT	KEY SINGLE*** <i>(with rubber boot)</i>	
--	96008-SGT	KEYSWITCH,3 POS. W/KEYS***	
--	96009GT	WASHER,NITRILE	
--	96010GT	SCREW,PHILLIPS,PHM,8-32 X.25**	
7	27246GT	BOOT,TOGGLE SWITCH,SHORT*.....1	1
8	66761GT	SERVICE KIT,E-STOP.....1 <i>(this is an update kit; the original E-stop button is no longer available from the supplier. Please note, if this kit has already been installed on the unit, refer to the part numbers listed below)</i>	1
--	66812GT	BUTTON,PUSH,RED MUSHROOM HEAD	
--	66817GT	BASE WITH 1 NC CONTACT, E-STOP	
--	66818GT	CONTACT,NC	
9	56100GT	HOUR METER,LCD,9-60 VDC***.....1 <i>(to SN 21064) (includes mounting bracket)</i>	1
9A	19506GT	HOUR METER,10-80 VOLTS***.....1 <i>(from SN 21065 to 28696) (includes mounting bracket)</i>	1
10	65734GT	CONTROL PANEL-LOWER.....1	1

212.2 Ground Controls (from SN 28696)

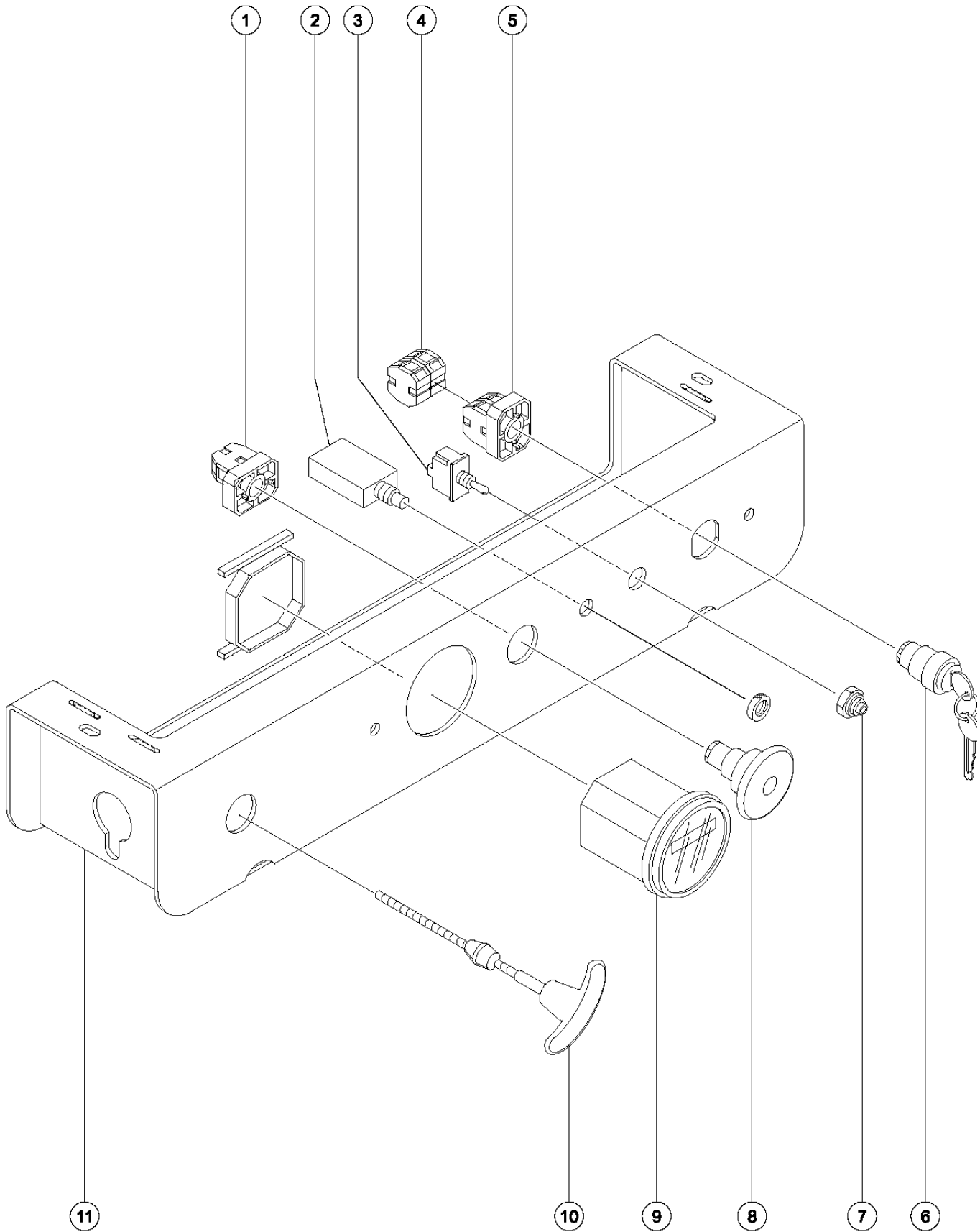

212.2 Ground Controls (from SN 28696)

Item	Part No.	Description	Qty.	Item	Part No.	Description	Qty.
1	66817GT	BASE WITH 1 NC CONTACT, E-STOP...1 <i>(includes 1 each N.C. contact)</i>	1	8	66761GT	SERVICE KIT,E-STOP.....1 <i>(to SN 36366) (Complete)</i>	1
--	68818GT	Contact - N.C.....1	1	--	66812GT	BUTTON,PUSH,RED MUSHROOM HEAD <i>(to SN 36366)</i>	1
2	96452GT	CIRCUIT BREAKER,7.0 AMP*** .....1 <i>(includes mounting fasteners)</i>	1	--	66817GT	BASE WITH 1 NC CONTACT, E-STOP <i>(to SN 36366)</i>	1
3	T114691GT	ASSY,SWITCH,TOGGLE,SPDT***** .....1 <i>(direct replacement for 13037-S and 96418)</i>	1	8A	66812GT	BUTTON,PUSH,RED MUSHROOM HEAD.....1 <i>(from SN 36367)</i>	1
--	13826GT	TERMINAL,FEM.BUTT SEAM:16/14.....4 <i>(to update 13037-S)</i>	4	--	94506GT	BASE,W/3 NC CONTACTS <i>(from SN 36367)</i>	1
4		Ref. Contact.....1 <i>(to SN 36366) (refer to item 6)</i>	1	9	56100GT	HOUR METER,LCD,9-60 VDC*** .....1 <i>(to SN 40625) (includes mounting bracket)</i>	1
4A	66816GT	CONTACT,N.O.....2 <i>(from SN 36367)</i>	2	9A	19506GT	HOUR METER,10-80 VOLTS*** .....1 <i>(from SN 40626) (includes mounting bracket)</i>	1
5		Ref. Base, Push button.....1 <i>(to SN 36366) (refer to item 6)</i>	1	10		Ref. Cable - Manual Lowering.....1 <i>(refer to Figure 202.2)</i>	1
5A	66814GT	BASE,WITH 2 N.O. CONTACTS*** .....1 <i>(from SN 36367) (includes 2 each N.O. contacts)</i>	1	11	66459GT	CONTROL PANEL,LWR, GS46*** .....1	1
6	96011GT	KIT, KEYSWITCH*** .....1 <i>(to SN 36366) (this is an update kit; the original key switch is no longer available from the supplier. Please note, if this kit has already been installed on the unit, refer to the part numbers listed below) (includes 1 pair of keys)</i>	1				
--	21982GT	KEY,SINGLE***					
--	37947GT	KEYS,10 PACK***					
--	96008-SGT	KEYSWITCH,3 POS. W/KEYS*** <i>(to SN 36366)</i>					
--	96009GT	WASHER,NITRILE <i>(to SN 36366)</i>					
--	96010GT	SCREW,PHILLIPS,PHM,8-32 X.25** <i>(to SN 36366)</i>					
6A	66811GT	KEYSWITCH,3POS.MNTND.DR WKEY** .....1 <i>(from SN 36367 to 48718) (includes the keyswitch and one set of keys, not included: base and contacts)</i>	1				
--	21982GT	KEY,SINGLE***					
--	37947GT	KEYS,10 PACK***					
6B	96008-SGT	KEYSWITCH,3 POS. W/KEYS*** <i>(from SN 48719) (includes 1 pair of keys)</i>					
--	83093GT	KEY SINGLE*** <i>(from SN 48719)</i>					
--	96009GT	WASHER,NITRILE <i>(from SN 48719)</i>					
--	96010GT	SCREW,PHILLIPS,PHM,8-32 X.25** <i>(from SN 48719)</i>					
--	96011GT	KIT, KEYSWITCH*** .....1 <i>(from SN 48719) (includes base and contact)</i>	1				
7	27246GT	BOOT,TOGGLE SWITCH,SHORT*.....1	1				



213.1 Hydraulic Hoses and Fittings (to SN 36044)

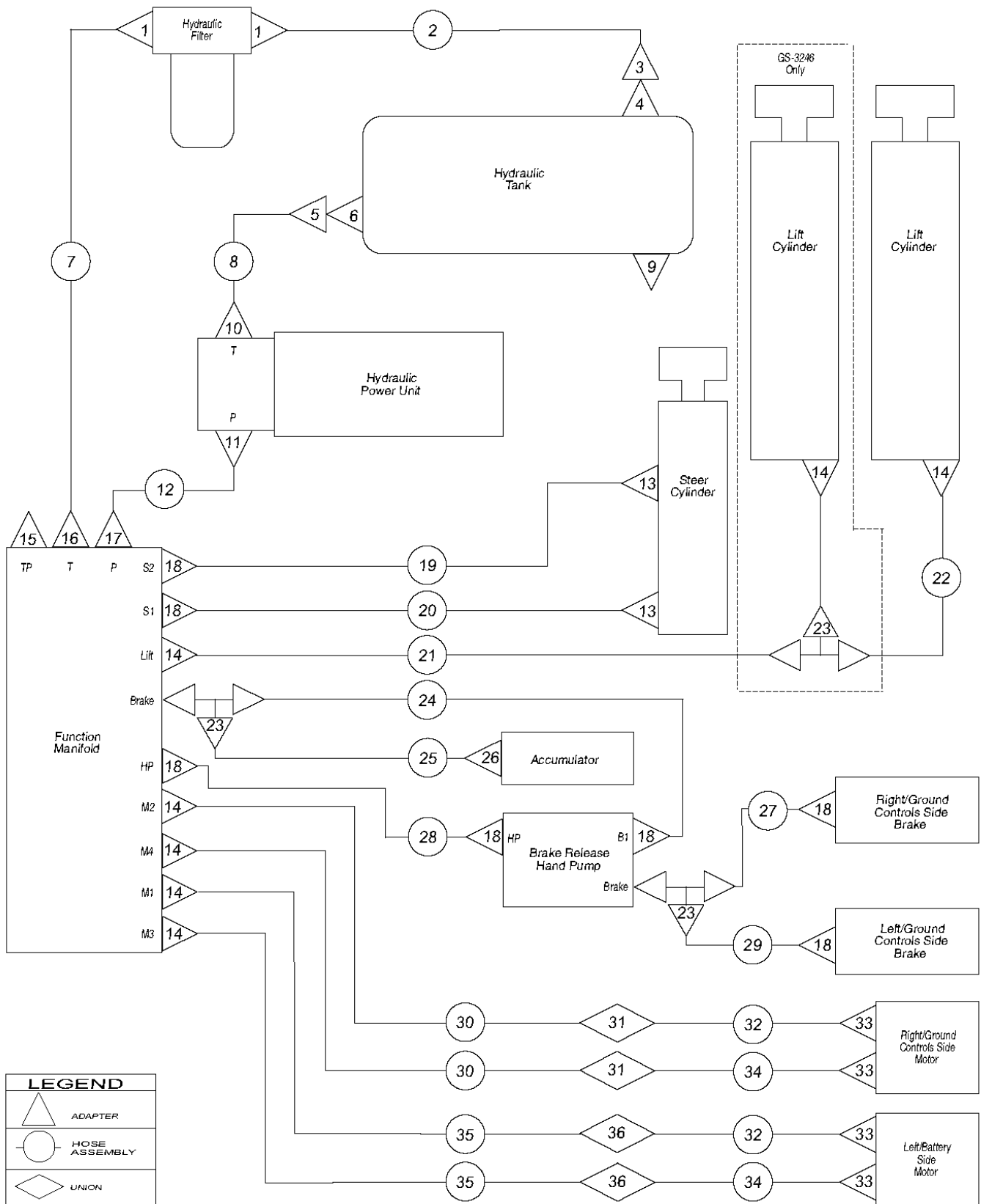

213.1 Hydraulic Hoses and Fittings (to SN 36044)

Item	Part No.	Description	Qty.	Item	Part No.	Description	Qty.
--		<i>The hose lengths below reflect the length of the hose only. Refer to the 'Fittings Cross Reference' to match Genie part numbers to Parker part numbers.</i>		25	78864GT	HOSE ASSY, MAN/ACCUM, MINI.....1 <i>(components: 78855, 78855, 78852 @ 20 inches)</i>	1
1	39883GT	CONNECTOR,070102-8-8.....2		26	39879GT	CONNECTOR,070120-4-8.....1	1
2	47442GT	HOSE ASSY,FILTER/TANK GS32&46.....1 <i>(components: 55967 and 39888 @ 29 inches)</i>		27	78879GT	HOSE ASSY, HANDPUMP/R BRAKE,46.....1 <i>(components: 78855, 78855, 78852 @ 18.12 inches)</i>	1
3		Ref. Clamp.....1 <i>(refer to Figure 209.1)</i>		28	47643GT	HOSE ASSY,MANIFOLD/HANDPUMP....1 <i>(components: 78855, 78855, 39887 @ 100 inches)</i>	1
4		Ref. Fitting.....1 <i>(refer to Figure 209.1)</i>		29	78878GT	HOSE ASSY, HANDPUMP/L BRAKE,46.....1 <i>(components: 78855, 78855, 78852 @ 25.87 inches)</i>	1
5		Ref. Clamp.....1 <i>(refer to Figure 209.1)</i>		30	47638GT	HOSE ASSY,MANIFOLD/BULKHEAD....2 <i>(components: 39890, 39890, 56776 @ 30 inches)</i>	2
6		Ref. Strainer.....1 <i>(refer to Figure 209.1)</i>		31	39871GT	ELBOW,070701-6.....2	2
7	47440GT	HOSE ASSY,MANIFOLD/FILTER.....1 <i>(components: 49213, 49213, 39888 @ 5.10 inches)</i>		32	47631GT	HOSE ASSY,BULKHEAD/DRIVE MOTOR.....2 <i>(components: 39890, 39892, 56776 @ 29.25 inches)</i>	2
8	47636GT	HOSE ASSY,HYD.TANK/PUMP.....1 <i>(components: 39895, 39895, 39889 @ 6 inches)</i>		--	66765-3000GT	WIRE LOOM,SPIRAL,1-5/8 ID 30".....2 <i>(sold seperately)</i>	2
9	39227GT	PLUG,HEX HEAD-8 PLASTIC.....1		33	39880GT	CONNECTOR,070120-6-10.....4	4
10	47670GT	ELBOW,90DEG.....1		34	47630GT	HOSE ASSY,BULKHEAD/DRIVE MOTOR.....2 <i>(components: 39890, 39891, 56776 @ 27.25 inches)</i>	2
11	39876GT	ELBOW,070220-6-8.....1		35	47639GT	HOSE ASSY,MANIFOLD/BULKHEAD....2 <i>(components: 39890, 39891, 56776 @ 30.25 inches)</i>	2
12	47441GT	HOSE ASSY,PUMP TO MANIFOLD.....1 <i>(components: 39890, 39890, 56776 @ 27 inches)</i>		36	39870GT	BULKHEAD,UNION,070601-6.....2	2
13	39875GT	ELBOW,070220-4-6.....2					
14	39878GT	CONNECTOR,070120-6-6.....6					
15	48997GT	NIPPLE,DIAGNOSTIC,#4.....1					
--	20224GT	DIAGNOSTIC FEMALE Q-DSCNT.....1					
--	48880GT	CAP,DIAGNOSTIC NIPPLE.....1					
16	39874GT	ELBOW,070220-8-6.....1					
17	39873GT	ELBOW,070220-6-6.....1					
18	39877GT	CONNECTOR,070120-4-4.....7					
19	78876GT	HOSE ASSY, MAN/STEER CYL, 46.....1 <i>(components: 78855, 78855, 78852 @ 51.62 inches)</i>					
20	47633GT	HOSE ASSY,MNFLD TO STEER CYL....1 <i>(components: 78855, 78855, 39887 @ 51.62 inches)</i>					
21	47641GT	HOSE ASSY,MNFLD TO LIFT CYL.....1 <i>(components: 39890, 47223, 56776 @ 136.50 inches)</i>					
22	47012GT	FLARE TUBE ASSY,LIFT CYLINDER....1					
23	39872GT	TEE,RUN,070428-4.....2					
24	78877GT	HOSE ASSY, MAN/HANDPUMP, 46.....1 <i>(components: 78855, 78855, 78852 @ 95 inches)</i>					



213.2 Hydraulic Hoses and Fittings (from 36045)

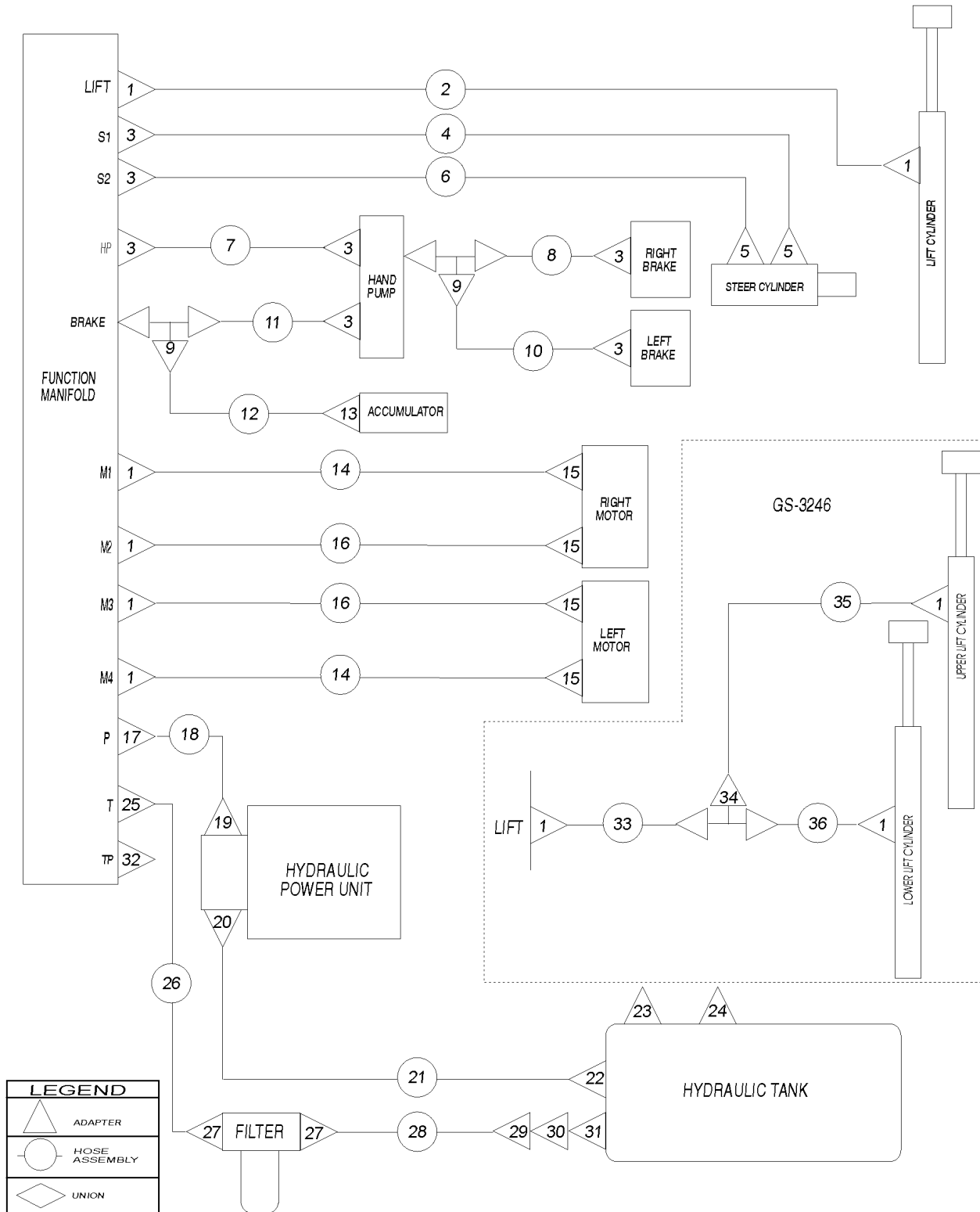

213.2 Hydraulic Hoses and Fittings (from 36045)

Item	Part No.	Description	Qty.	Item	Part No.	Description	Qty.
--		<i>The hose lengths below reflect the length of the hose only. Refer to the 'Fittings Cross Reference' to match Genie part numbers to Parker part numbers.</i>		14	105801GT	HOSE ASSY,DRIVE MOTORS,GS46.....2 <i>(components: 39890, 39890, 56776 @ 60 inches)</i>	
1	39878GT	CONNECTOR,070120-6-6.....	9	--	66765-3000GT	WIRE LOOM, SPIRAL, 1-5/8 ID 30".....	2
2	66165GT	HOSE ASSY, MAN TO LIFT, GS46.....1 <i>(components: 39890, 39890, 56776 @ 173 inches)</i>		15	39880GT	CONNECTOR,070120-6-10.....	4
3	39877GT	CONNECTOR,070120-4-4.....	7	16	105580GT	HOSE ASSY,DRIVE MOTORS,GS46.....2 <i>(components: 39890, 39890, 56776 @ 64 inches)</i>	
4	47633GT	HOSE ASSY,MNFLD TO STEER CYL.....1 <i>Hose End - Female JIC Swivel (Parker No. 10657-4-2), Hose End - Female JIC Swivel (Parker No. 10657-4-2) and Hose, 1/8" Thermoplastic Medium Pressure (Parker No. 540N-2) @ 51.62 inches (1.311m)</i>		17	39873GT	ELBOW,070220-6-6.....	1
5	39875GT	ELBOW,070220-4-6.....	2	18	47441GT	HOSE ASSY,PUMP TO MANIFOLD.....1 <i>Hose End - Female JIC Swivel (Parker No. 10648-6-6), Hose End - Male, Rigid (Parker No. 10348-6-6) and Hose, 3/8" Hydraulic (Parker No. 471TC-6) @ 27 inches (68.6 cm)</i>	
6	78876GT	HOSE ASSY, MAN/STEER CYL, 46.....1 <i>Hose End - Female JIC Swivel (Parker No. 10657-4-2), Hose End - Female JIC Swivel (Parker No. 10657-4-2) and Hose, 1/8" Thermoplastic Medium Pressure (Parker No. 540N-2) @ 48.62 inches (1.235 m)</i>		19	39890GT	HOSE END,FEM.SWIV,JIC 6-6.....	1
7	47643GT	HOSE ASSY,MANIFOLD/HANDPUMP....1 <i>Hose End - Female JIC Swivel (Parker No. 10657-4-2), Hose End - Female JIC Swivel (Parker No. 10657-4-2) and Hose, 1/8" Thermoplastic Medium Pressure (Parker No. 540N-2) @ 100 inches (2.54 m) @ 95 inches (2.413 m)</i>		20	55968GT	ELBOW,070220-10.....	1
8	78879GT	HOSE ASSY, HANDPUMP/R BRAKE,46.....1 <i>Hose End - Female JIC Swivel (Parker No. 10657-4-2), Hose End - Female JIC Swivel (Parker No. 10657-4-2) and Hose, 1/8" Thermoplastic Medium Pressure (Parker No. 540N-2) @ 18.12 inches (46 cm)</i>		21	66205GT	HOSE ASSY, HYD. TANK/PUMP.....1 <i>Hose End - Barbed Swivel (Parker No. 30682-10-12) and Hose, 1/8" Thermoplastic Medium Pressure (Parker No. 540N-2) 12.5 inches (31.8 cm)</i>	
9	39872GT	TEE,RUN,070428-4.....	2	22		Ref. Strainer.....	1
10	78878GT	HOSE ASSY, HANDPUMP/L BRAKE,46.....1 <i>Hose End - Female JIC Swivel (Parker No. 10657-4-2), Hose End - Female JIC Swivel (Parker No. 10657-4-2) and Hose, 1/8" Thermoplastic Medium Pressure (Parker No. 540N-2) @ 23.87 inches (60.6 cm)</i>		23		Ref. Plug.....	1
11	47643GT	HOSE ASSY,MANIFOLD/HANDPUMP....1 <i>Hose End - Female JIC Swivel (Parker No. 10657-4-2), Hose End - Female JIC Swivel (Parker No. 10657-4-2) and Hose, 1/8" Thermoplastic Medium Pressure (Parker No. 540N-2)</i>		24		Ref. Breather.....	1
12	78864GT	HOSE ASSY, MAN/ACCUM, MINI.....1 <i>(components: 78855, 78855, 78852 @ 20 inches)</i>		25	39874GT	ELBOW,070220-8-6.....	1
13	39879GT	CONNECTOR,070120-4-8.....	1	26	66945GT	HOSE ASSY,MNFLD. FILTER.....1 <i>Hose End - Barbed Swivel (Parker No. 30682-8-8), Hose End - Barbed Swivel (Parker No. 30682-8-8) and Hose, 1/2" Push-On (Parker No. 801-8) @ 5.1 inches (13 cm)</i>	
				27	55967GT	HOSE END,BARBED SWIVEL,8,MALE.....	1
				28	55837GT	HOSE ASSY, FILTER/TANK GS32/46.....1 <i>Hose End - Barbed Swivel (Parker No. 30682-8-8), Hose End - Barbed Swivel (Parker No. 30682-8-8) and Hose, 1/2" Push-On (Parker No. 801-8) @ 28 inches (71.1 cm)</i>	
				29		Ref. Fitting(refer to Figure 2-I.1).....	1
				30	39223GT	BULKHEAD FITTING,PLASTIC X 8**.....	1
				31	39226GT	NIPPLE,PLASTIC .5 NPT X 6".....	4
				32	48997GT	NIPPLE,DIAGNOSTIC,#4.....	1
				--	20224GT	DIAGNOSTIC FEMALE Q-DSCNT.....	1
				--	48880GT	CAP,DIAGNOSTIC NIPPLE.....	1
				33	51625GT	HOSE ASSY,LIFT/MAN TO TEE FIT.....1 <i>Hose End - Female JIC Swivel (Parker No.10648-6-6), Hose End - Male, Rigid (Parker No. 10348-6-6) and Hose, 3/8" Hydraulic (Parker No. 471TC-6) @ 108.62 inches (275.9 cm)</i>	



213.2 Hydraulic Hoses and Fittings (from 36045)  
(continued)

Item	Part No.	Description	Qty.
34	66392GT	TEE,RUN,070428-6.....	1
35	66283GT	HOSE ASSY, TEE TO 1ST CYLIN..... <i>Hose End - Female JIC Swivel (Parker No.10648-6-6), Hose End - Female JIC Swivel (Parker No.10648-6-6) and Hose, 3/8" Hydraulic (Parker No. 471TC-6) @ 64 inches (1.625 m)</i>	1
36	66284GT	HOSE ASSY, TEE TO 2ND CYLIN..... <i>Hose End - Female JIC Swivel (Parker No.10648-6-6), Hose End - Female JIC Swivel (Parker No.10648-6-6) and Hose, 3/8" Hydraulic (Parker No. 471TC-6) @ 228 inches (5.791 m)</i>	1





---

213.2 Hydraulic Hoses and Fittings (from 36045)  
(continued)

***This Page Intentionally Left Blank***

214.1 Power Cables - Drive Chassis (to SN 6899)

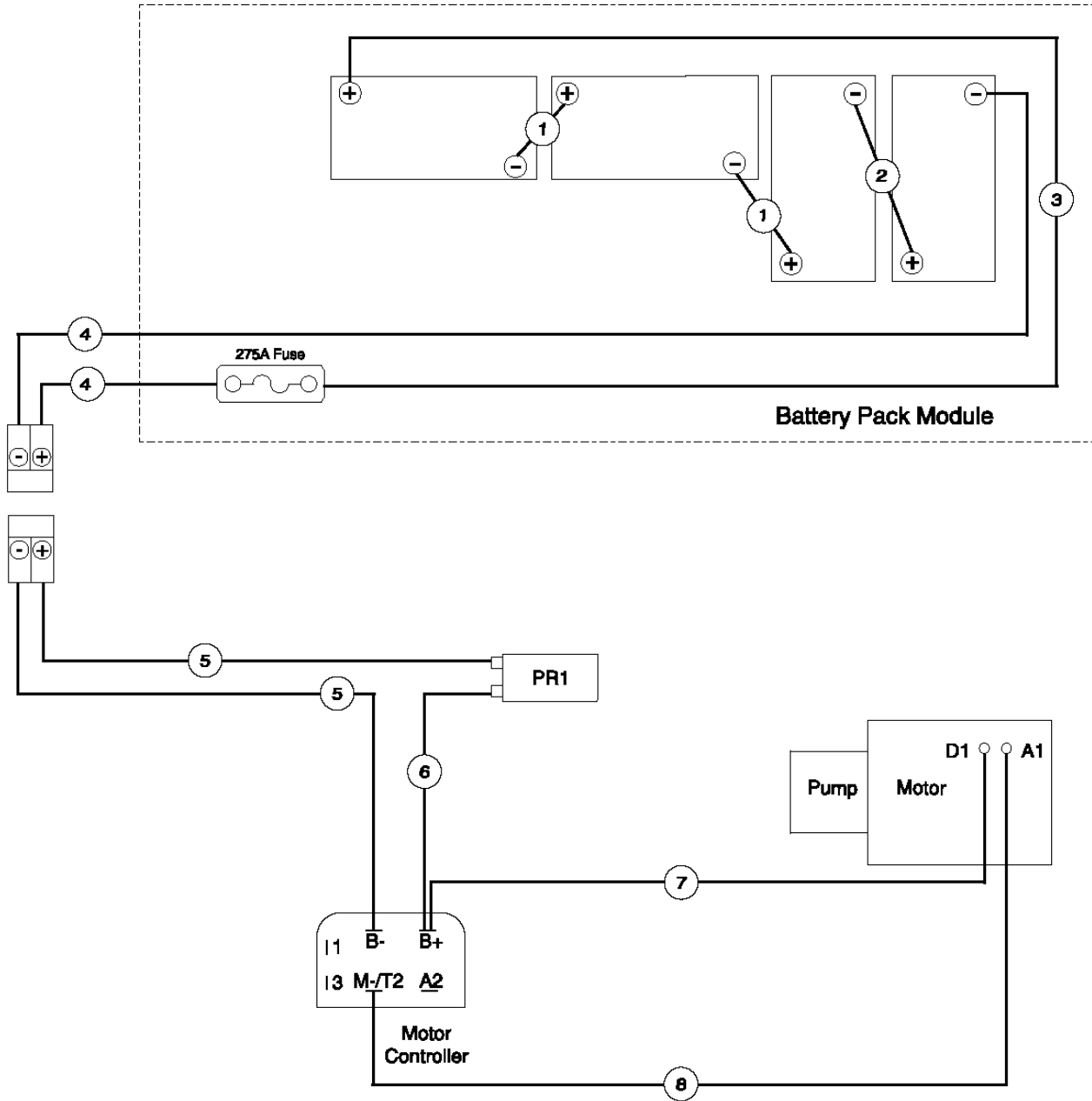

214.1 Power Cables - Drive Chassis (to SN 6899)

Item	Part No.	Description	Qty.
--	105907GT	HARNESS,GS20/2646 <i>from SN 1 to 6899; chassis wire harness</i>	
--	105911GT	E-DOWN HARNESS <i>from SN 1 to 6899; e-down wire harness, GS-2046</i>	
--	105912GT	E-DOWN HARNESS <i>from SN 1 to 6899; e-down wire harness, GS-2646</i>	
--	105914GT	E-DOWN HARNESS <i>from SN 1 to 6899; e-down wire harness, GS-3246</i>	
--		Ref. Fuse, 275A <i>(refer to Figure 205.1)</i>	
1	44244GT	BATTERY CABLE ASSY,3.5" RED.....	2
2	46225GT	CABLE ASSEMBLY,9" RED.....	1
3	40552GT	CABLE ASSEMBLY,13"(SCISSORS).....	1
4	48664GT	BATT CABLE ASSY-BATT.MOD, 2646.....	1
--	19436GT	CONNECTOR,ANDERSON SB 175,1/0G.....	1
5	48665GT	BATT CABLE ASSY.CHASSIS-2646.....	1
--	66397GT	QUICK DISCONNECT CASING,BATT**.....	1
6	49904GT	CABLE ASSEMBLY,13" RED.....	1
7	49903GT	CABLE ASSEMBLY,11"(SCISSORS).....	1
8	49906GT	CABLE ASSEMBLY,13" BLACK.....	1

214.2 Power Cables - Drive Chassis (from SN 6900)

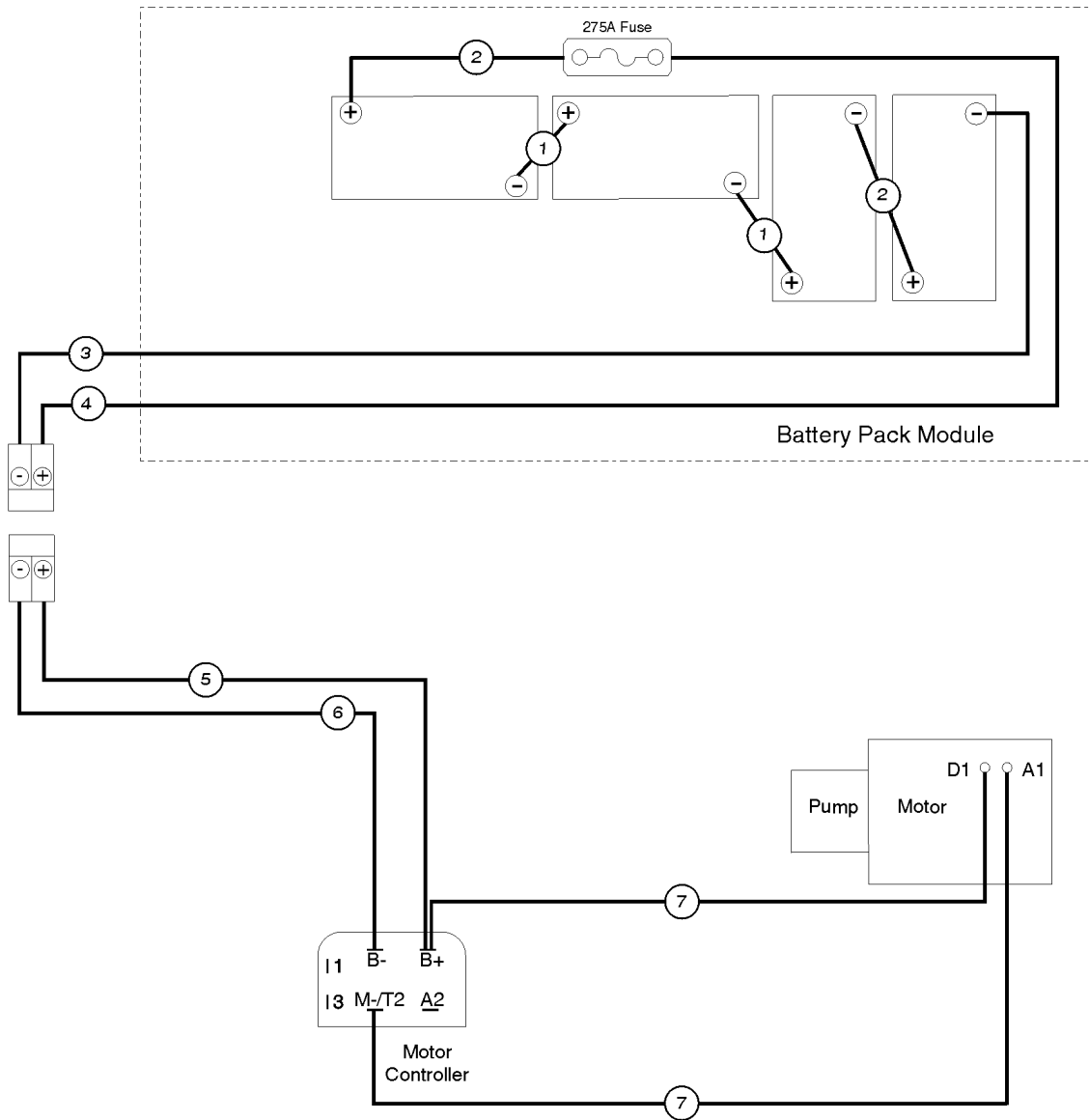

214.2 Power Cables - Drive Chassis (from SN 6900)

Item	Part No.	Description	Qty.
--	105907GT	HARNESS,GS20/2646 <i>from SN 6900 to 12084; chassis wire harness</i>	
--	144421GT	HARNESS, GS46 <i>from SN 12085 to 17407; chassis wire harness</i>	
--	105908GT	HARNESS,GS46 <i>from SN 17408 to 25110; chassis wire harness</i>	
--	105909GT	HARNESS,GS32/46 <i>from SN 25111 to 48717; chassis wire harness</i>	
--	105910GT	HARNESS,GS32/46 <i>from SN 48718 to 59999; chassis wire harness</i>	
--	105911GT	E-DOWN HARNESS <i>from SN 6900 to 59999; e-down wire harness, GS-2046</i>	
--	105912GT	E-DOWN HARNESS <i>from SN 6900 to 59999; e-down wire harness, GS-2646</i>	
--	105914GT	E-DOWN HARNESS <i>from SN 6900 to 59999; e-down wire harness, GS-3246</i>	
--	51590	RESISTOR, 75 OHM,DALE RS-10-38	
--		Ref. Fuse, 275A <i>(refer to Figure 205.1 or 205.2)</i>	
1	78716GT	BATTERY CABLE ASSY,RED.....	2
2	49904GT	CABLE ASSEMBLY,13" RED.....	2
3	66961GT	BATTERY CABLE ASSY 75" BLK QD.....	1
4	66960GT	BATTERY CABLE ASSY 25" RED QD....	1
--	19436GT	CONNECTOR,ANDERSON SB 175,1/0G.....	1
5	66962GT	BATTERY CABLE ASSY 153" RED QD.....	1
--	66397GT	QUICK DISCONNECT CASING,BATT**.....	1
6	66963GT	BATTERY CABLE ASSY 156" BLK QD...	1
7	49906GT	CABLE ASSEMBLY,13" BLACK.....	2

301.1 Scissor Assembly, GS-2046, View 1 (to SN 23567)

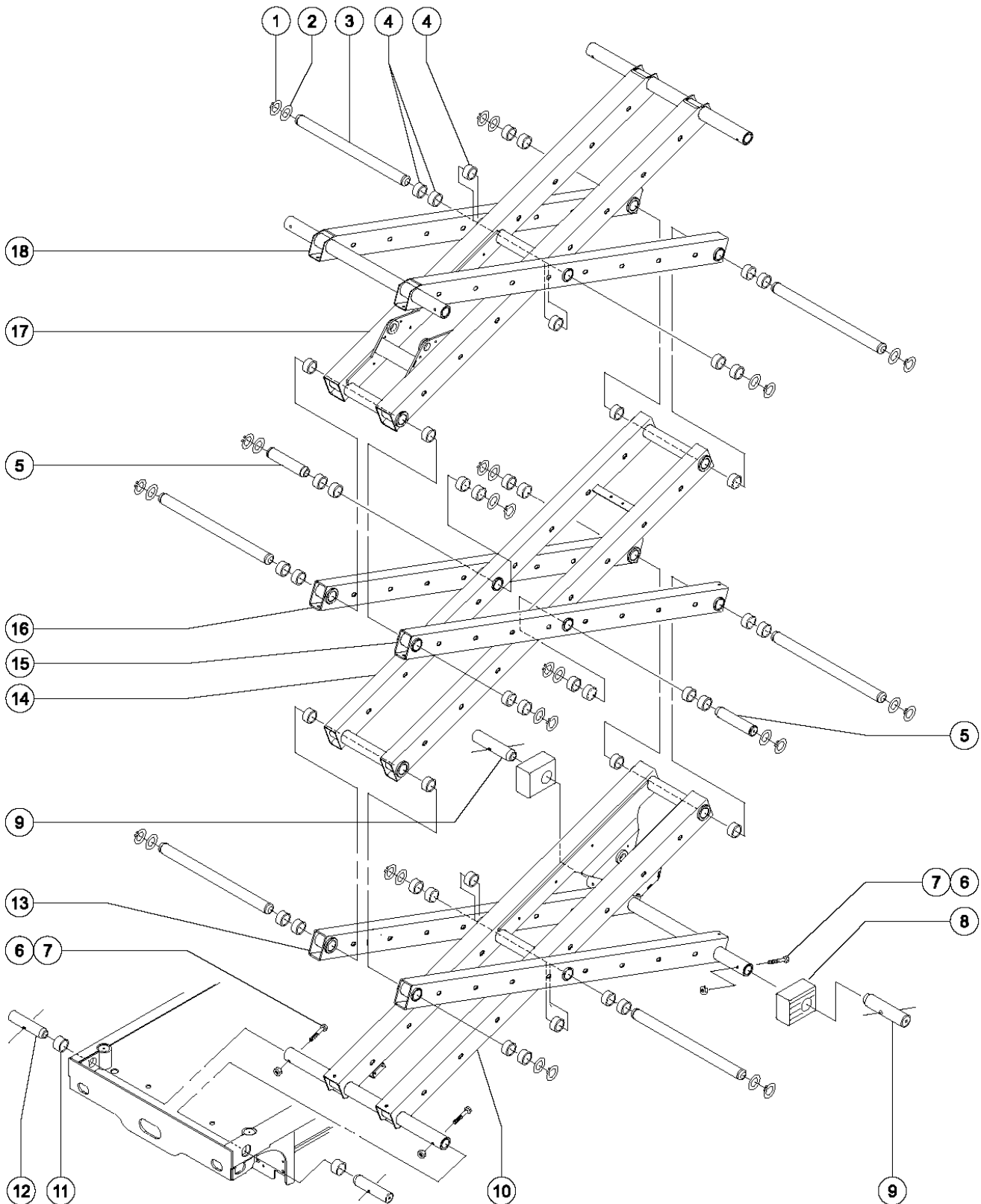

## 301.1 Scissor Assembly, GS-2046, View 1 (to SN 23567)

Item	Part No.	Description	Qty.
1	18384GT	SNAP RING,EXTERNAL,1.75 DIA.....16 (4.44 cm)	
2	39127GT	WASHER,SCIS ARM,1.79X2.25X.120.....16	
3	47301GT	PIN,1.75DIA X 26.71LG,2RING.....6 (68.28 x 4.445 cm)	
4	51144GT	BEARING,1.75ID X 2.00OD X 1.25L.....44 (4.45 x 5.08 x 3.18 cm)	
5	47302GT	PIN,1.75DIA X 8.51LG,2RING.....2 (22.07 x 4.445 cm)	
6	14033GT	SCREW,HHC,3/8-16 X 2.75.....4	
7	4828GT	NUT,NYLOCK,3/8-16.....4	
8	47510GT	SLIDER,BASE CHASSIS,46.....2	
9	39095GT	PIN,1.75DIA X 7.35LG,CHAMFER.....2 (18.77 x 4.445 cm)	
10	48344GT	ARM-#1 INNER W/DECALS GS2646.....1 (includes 4 each item 4)	
11	51763GT	BEARING,FL,1.75ID X 2.25OD X .85L.....2 (4.45 x 5.08 x 6.35 cm)	
12	47102GT	PIN,1.75DIA X 7.94LG, 1HOLE.....2 (20.17 x 4.445 cm)	
13	48345GT	ARM-#1 OUTER W/BEARINGS GS2646.....1 (includes 8 each item 4)	
14	48346GT	ARM-#2 INNER W/BEARINGS,GS2646.....1 (includes 8 each item 4)	
15	48349GT	ARM-#3 OUTER W/BEARING GS2646...1 (battery pack side) (includes 6 each item 4)	
16	48347GT	ARM-#2 OUTER W/BEARINGS GS2646.....1 (ground controls side) (includes 6 each item 4)	
17	52266GT	ARM-#3 INNER (GS-2046).....1 (includes 4 each item 4)	
18	52268GT	ARM-#3 OUTER (GS-2046).....1 (includes 8 each item 4)	

301.2 Scissor Assembly, GS-2046, View 1 (from SN 23568)

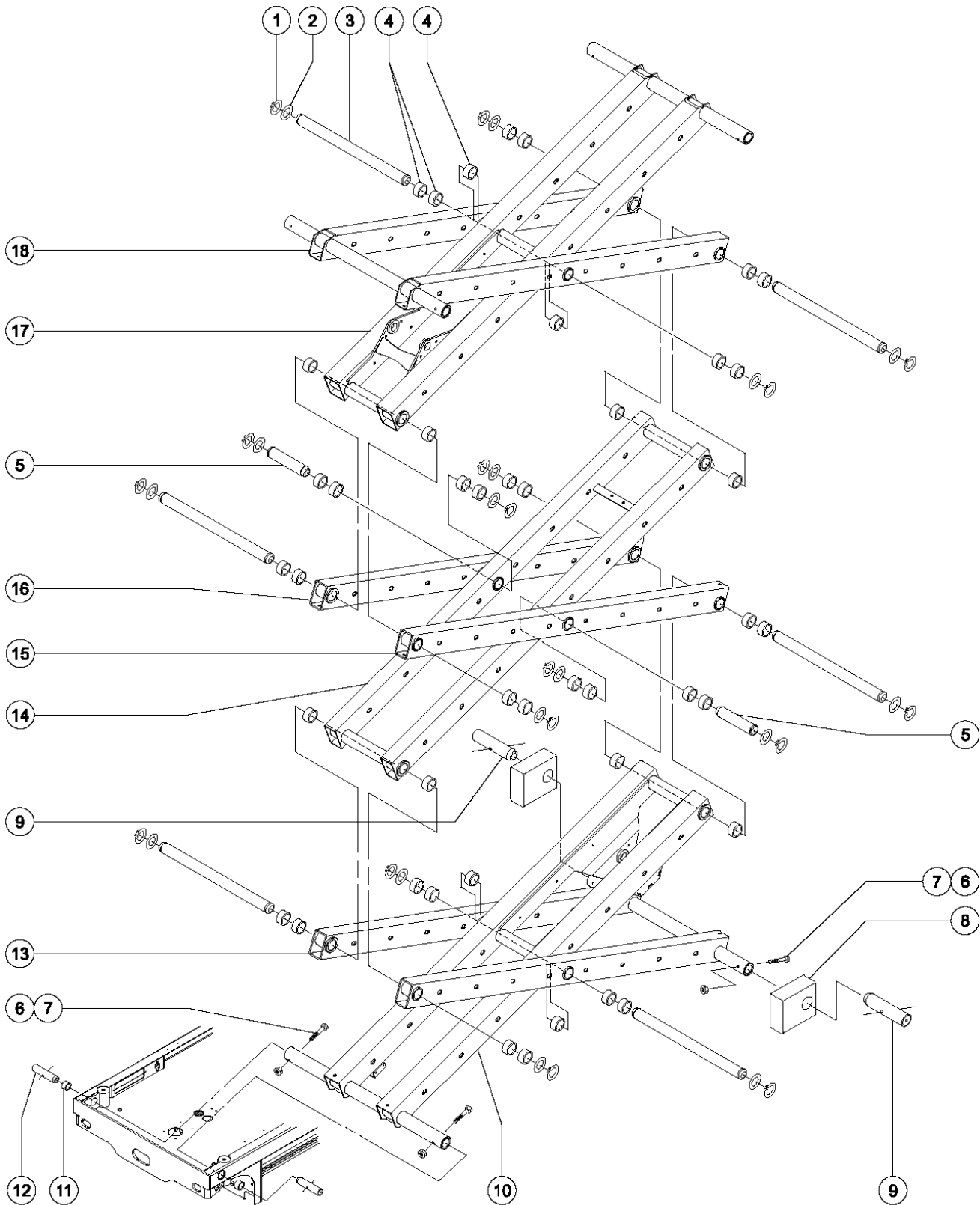



## 301.2 Scissor Assembly, GS-2046, View 1 (from SN 23568)

Item	Part No.	Description	Qty.
1	18384GT	SNAP RING,EXTERNAL,1.75 DIA.....	16
2	39127GT	WASHER,SCIS ARM,1.79X2.25X.120.....	16
3	47301GT	PIN,1.75DIA X 26.71LG,2RING..... (68.28 x 4.445 cm)	6
4	51144GT	BEARING,1.75IDX2.00ODX1.25L..... (4.45 x 5.08 x 3.18 cm)	44
5	47302GT	PIN,1.75DIA X 8.51LG,2RING..... (22.07 x 4.445 cm)	2
6	14033GT	SCREW,HHC,3/8-16 X 2.75.....	4
7	4828GT	NUT,NYLOCK,3/8-16.....	4
8	47510GT	SLIDER,BASE CHASSIS,46.....	2
9	39095GT	PIN,1.75DIA X 7.35LG,CHAMFER..... (4.4 x 19 cm)	2
10	52267GT	ARM-#1 INNER W/DECALS, GS2046.... (includes 4 each item 4)	1
11	51763GT	BEARING,FL,1.75IDX2.25ODX.85L..... (4.45 x 5.08 x 6.35 cm)	2
12	47102GT	PIN,1.75DIA X 7.94LG, 1HOLE..... (20.17 x 4.445 cm)	2
13	48345GT	ARM-#1 OUTER W/BEARINGS GS2646..... (includes 8 each item 4)	1
14	48346GT	ARM-#2 INNER W/BEARINGS,GS2646..... (includes 8 each item 4)	1
15	48349GT	ARM-#3 OUTER W/BEARING GS2646... (battery pack side) (includes 6 each item 4)	1
16	48347GT	ARM-#2 OUTER W/BEARINGS GS2646..... (ground controls side) (includes 6 each item 4)	1
17	52326GT	ARM-#5 INNER W/BEARINGS,GS3246..... (includes 4 each item 4)	1
18	48351GT	ARM-#4 OUTER W/BEARING GS2646... (includes 8 each item 4)	1

302.1 Scissor Assembly, GS-2046, View 2 (to SN 23567)

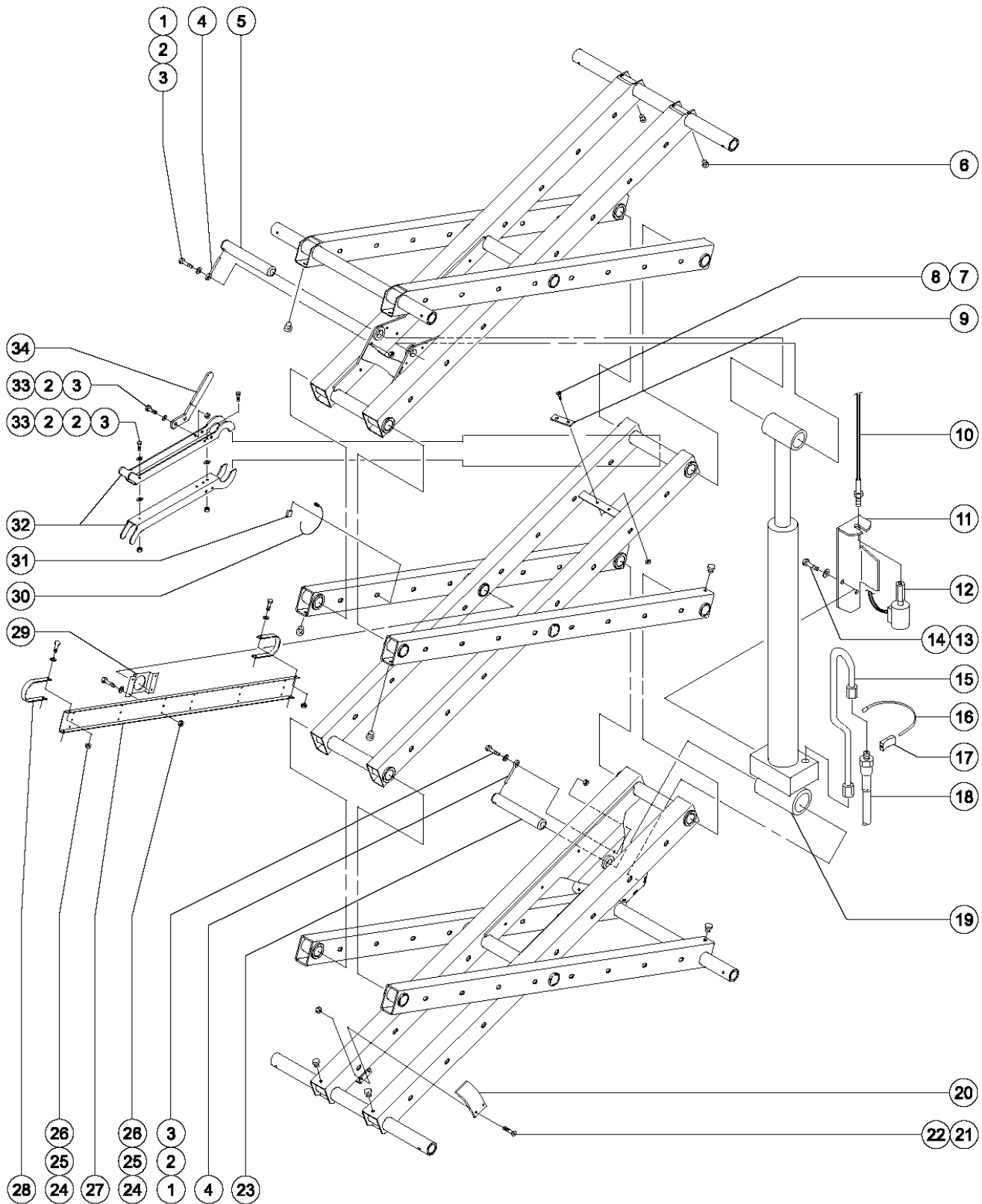

302.1 Scissor Assembly, GS-2046, View 2 (to SN 23567)

Item	Part No.	Description	Qty.	Item	Part No.	Description	Qty.
1	8516GT	SCREW,HHC,3/8-16 X 1.50,GR5.....	2	31	39560GT	CLIP,CABLE TIE MOUNT.....	20 <i>(quantities vary)</i>
2	6097GT	WASHER,FLAT,USS,3/8",Y.....	8	32	58000GT	SAFETY CHOCK,SCISSOR.....	1
3	4828GT	NUT,NYLOCK,3/8-16.....	8	--	4828GT	NUT,NYLOCK,3/8-16.....	1
4	45226GT	ROD END,,375 X 3.69.....	2	--	60790GT	BOLT, CARRIAGE, 3/8-16 X 1.50, G5.....	1
5	47955GT	PIN,1.50DIAX10.45LG,1HOLE.....	1	--	78901GT	FORMING,SAFETY ARM***.....	1
6	47502GT	BUMPER,1.25 INCH O.D.,SCISSORS.....	12	33	6175GT	SCREW,HHC,3/8-16 X 1.....	4
7	16439GT	SCREW,FHS,3/8-16 X 1.....	2	34	52356GT	HANDLE ASSY,SEE58000-S/58001-S....	1
8	7713GT	NUT, LP NYLOCK, 3/8-16.....	2	--	44733GT	HANDLE COVER,PLASTIC.....	1
9	51424GT	PAD,BUMPER SUPPORT.....	1				
10		Ref. Cable - Manual Platform Lowering... <i>(Includes mounting fasteners) (refer to Figure 202.1 or 202.2)</i>					
11	41557-SGT	CABLE BRACKET,PAINTED.....	1				
12	66465GT	VALVE,W/20V NC SOLENOID,MANUAL.....	1				
--	44973GT	NUT,COIL (39909).....	1				
--	44979GT	SEAL KIT,39909,PLAT LWR VALVE*.....	1				
--	84422GT	COIL-SOLENOID VALVE,20V DC***..... <i>(direct replacement for 44787)</i>	1				
13	7339GT	SCREW, HHC, 1/4-20 X .5.....	2				
14	6356GT	WASHER, LOCK, .25.....	2				
15	47012GT	FLARE TUBE ASSY,LIFT CYLINDER....	1				
16	28443GT	CABLE TIE,11.5" BLACK.....	1				
17	47046GT	CABLE TIE MOUNT.....	1				
18		Ref. Hydraulic Hoses and Fittings..... <i>(refer to Figure 214.1)</i>					
19	55717GT	CYLINDER, GS2632/46/68***..... <i>(includes orifice, spring, and fitting)</i>	1				
--	39878GT	CONNECTOR,070120-6-6.....	1				
--	45071GT	BEARING,1.5IDX1.75ODX1.5L.....	1				
--	48340GT	SEAL KIT, 48341 LIFT CYL.....	1				
--	55560GT	ORIFICE,LONG, .059".....	1				
20	47566GT	PLATE,LIFT ARM CAM 1930,32,46.....	1				
21	19284GT	SCREW,FHS,1/4-20 X .63.....	2				
22	6889GT	NUT,LP NYLOCK,1/4-20.....	2				
23	47458GT	PIN,1.50DIAX8.45LG,1HOLE.....	1				
24	6091GT	NUT,NYLOCK,1/4-20.....	12				
25	6638GT	WASHER,FLAT,USS,1/4"Y.....	12				
26	8914GT	SCREW, HHC, 1/4-20 X .625.....	12				
27	78686GT	FORMING,CABLE BRIDGE,MAIN***.....	1				
28	55351GT	CLAMP, CABLEBRIDGE,HALF..... <i>(older strap shown)</i>	4				
29	47625GT	BRACKET CABLE BRIDGE.....	1				
30	21121GT	CABLE TIE,4" BLK,HEAT RESISTNT.... <i>(quantities vary)</i>	20				

302.2 Scissor Assembly, GS-2046, View 2 (from SN 23568)

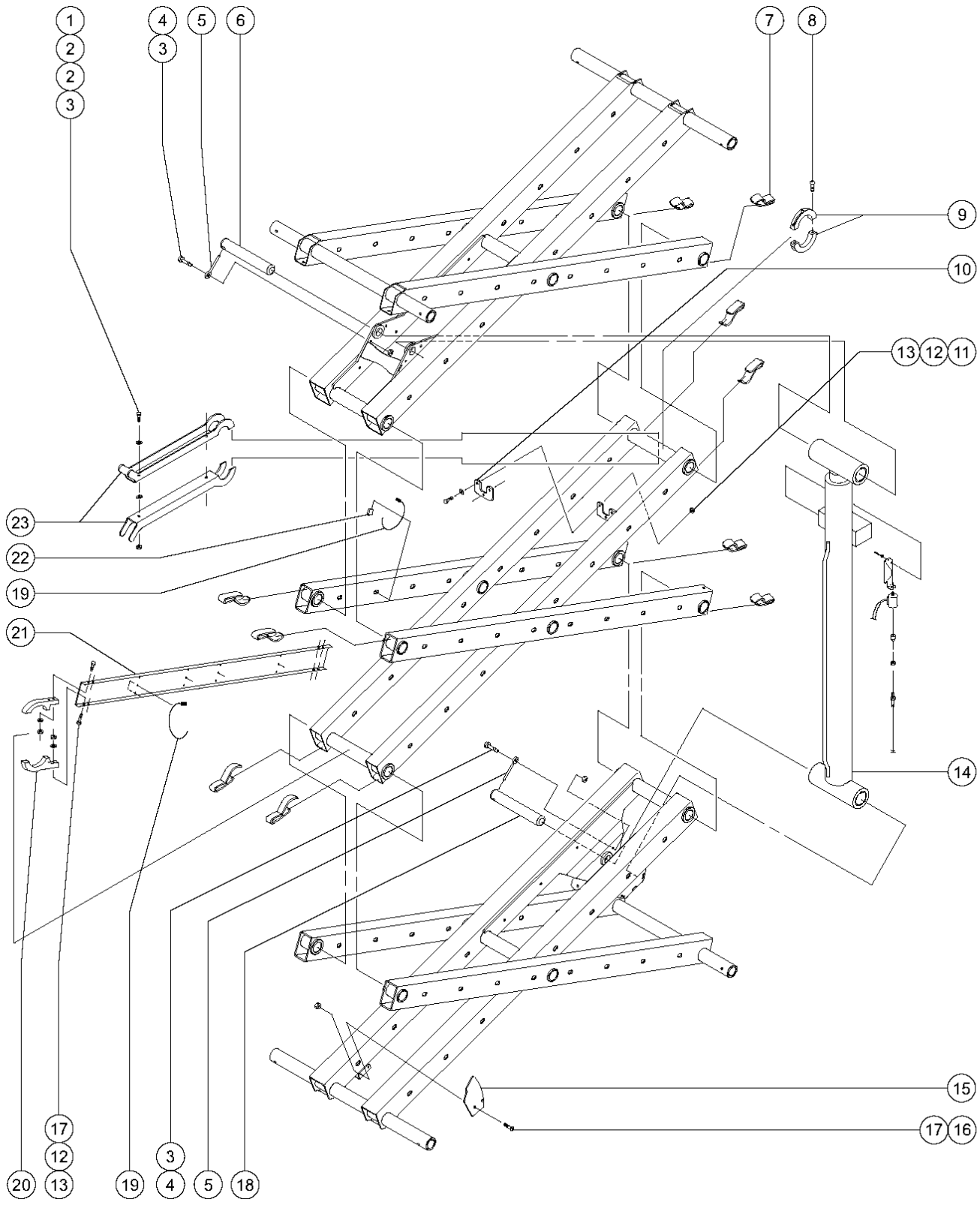

## 302.2 Scissor Assembly, GS-2046, View 2 (from SN 23568)

Item	Part No.	Description	Qty.
1	6019GT	SCREW,HHC,3/8-16 X 1.25 GRD 5.....	2
2	6097GT	WASHER,FLAT,USS,3/8",Y.....	4
3	4828GT	NUT,NYLOCK,3/8-16.....	4
4	8516GT	SCREW,HHC,3/8-16 X 1.50,GR5.....	2
5	45226GT	ROD END,.375 X 3.69.....	2
6	47955GT	PIN,1.50DIAX10.45LG,1HOLE.....	1
7	47502GT	BUMPER,1.25 INCH O.D.,SCISSORS.....	12 (to SN 42999)
7A	71349GT	BUMPER, LINK.....	12 (from SN 43000)
8	11966GT	SCREW,BHHS,1/4-20 X 1.5.....	1
9	55488GT	CROSS TUBE COLAR, GS46\68.....	2 (includes nut fastener)
--	6091GT	NUT,NYLOCK,1/4-20.....	1
10	55336GT	CHOCK STOP CUSHION.....	1
11	6091GT	NUT,NYLOCK,1/4-20.....	3
12	6638GT	WASHER,FLAT,USS,1/4"Y.....	11
13	6888GT	SCREW,HHC,1/4-20 X 1.....	11
14	58148GT	CYL.ASSY,2046-3268.....	1 (includes orifice and fitting)
--	39878GT	CONNECTOR,070120-6-6.....	1
--	45071GT	BEARING,1.5IDX1.75ODX1.5L.....	1
--	55560GT	ORIFICE,LONG, .059".....	1
--	66470GT	SEAL KIT (55717) TEXAS HYD VER.....	1
15	51596GT	PLATE,LIFT ARM CAM,GS-3246.....	1
16	8914GT	SCREW, HHC, 1/4-20 X .625.....	2
17	6889GT	NUT,LP NYLOCK,1/4-20.....	10
18	47666GT	PIN,1.50DIAX9.13LG,1HOLE.....	1
19	28443GT	CABLE TIE,11.5" BLACK.....	6
20	55351GT	CLAMP, CABLEBRIDGE,HALF.....	4
21	78686GT	FORMING,CABLE BRIDGE,MAIN***.....	1
22	39560GT	CLIP,CABLE TIE MOUNT.....	20 (quantities will vary)
23	58000GT	SAFETY CHOCK,SCISSOR.....	1 (includes items 1, 2 and 2 each item 3)

303.1 Scissor Assembly, GS-2646, View 1 (to SN 23567)

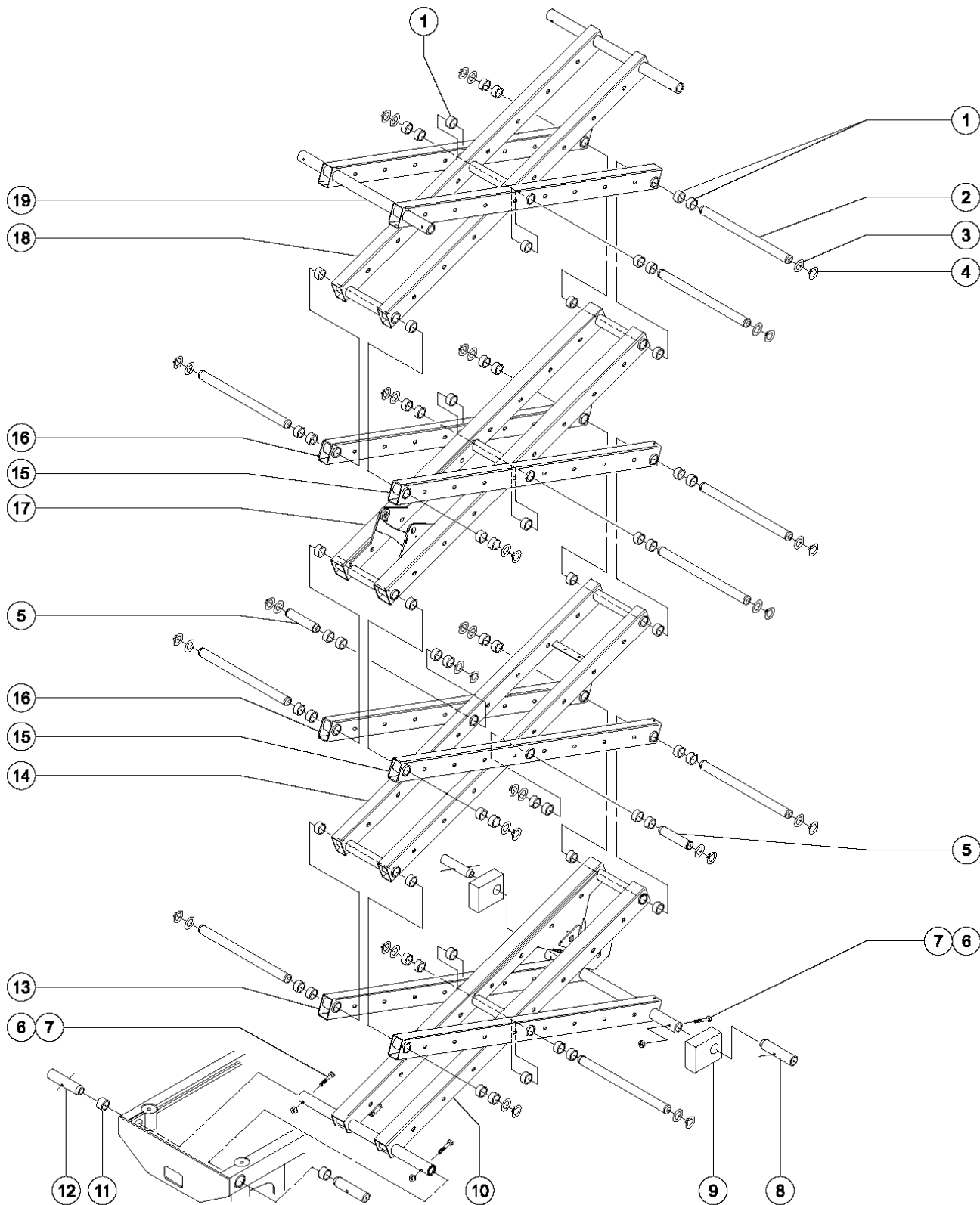

## 303.1 Scissor Assembly, GS-2646, View 1 (to SN 23567)

Item	Part No.	Description	Qty.
1	51144GT	BEARING,1.75IDX2.00ODX1.25L.....62 (4.45 x 5.08 x 3.18 cm)	
2	47301GT	PIN,1.75DIA X 26.71LG,2RING.....9 (67.84 x 4.445 cm)	
3	39127GT	WASHER,SCIS ARM,1.79X2.25X.120.....22 (4.55 x 5.72 x 0.32 cm)	
4	18384GT	SNAP RING,EXTERNAL,1.75 DIA.....22	
5	47302GT	PIN,1.75DIA X 8.51LG,2RING.....2 (21.62 x 4.445 cm)	
6	4828GT	NUT,NYLOCK,3/8-16.....4	
7	14033GT	SCREW,HHC,3/8-16 X 2.75.....4	
8	39095GT	PIN,1.75DIA X 7.35LG,CHAMFER.....2 (18.67 x 4.445 cm)	
9	47510GT	SLIDER,BASE CHASSIS,46.....2	
10	48344GT	ARM-#1 INNER W/DECALS GS2646.....1 (includes 4 each item 1)	
11	51763GT	BEARING,FL,1.75IDX2.25ODX.85L.....2 (4.45 x 5.08 x 6.35 cm)	
12	47102GT	PIN,1.75DIA.X7.94LG, 1HOLE.....2 (20.17 x 4.445 cm)	
13	48345GT	ARM-#1 OUTER W/BEARINGS GS2646.....1 (includes 8 each item 1)	
14	48346GT	ARM-#2 INNER W/BEARINGS,GS2646.....1 (includes 8 each item 1)	
15	48349GT	ARM-#3 OUTER W/BEARING GS2646...2 (battery pack side) (includes 6 each item 1)	
16	48347GT	ARM-#2 OUTER W/BEARINGS GS2646.....2 (ground controls side) (includes 6 each item 1)	
17	48348GT	ARM-#3 INNER W/BEARINGS,GS2646.....1 (includes 6 each item 1)	
18	48350GT	ARM-#4 INNER W/BEARINGS,GS2646.....1 (includes 4 each item 1)	
19	48351GT	ARM-#4 OUTER W/BEARING GS2646...1 (includes 8 each item 1)	

303.2 Scissor Assembly, GS-2646, View 1 (from SN 23568)

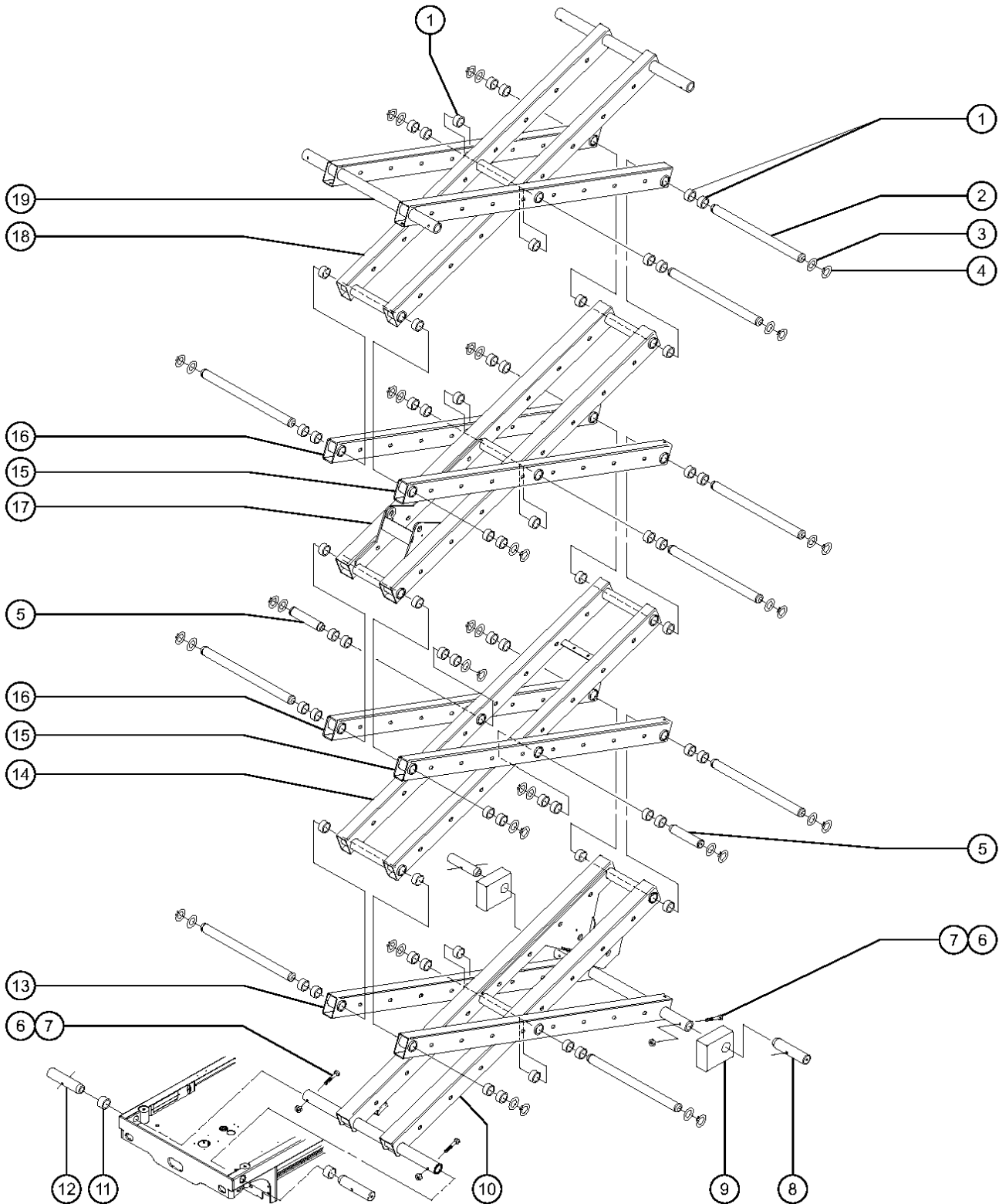

A TEREX BRAND



## 303.2 Scissor Assembly, GS-2646, View 1 (from SN 23568)

Item	Part No.	Description	Qty.
1	51144GT	BEARING,1.75IDX2.00ODX1.25L.....62 (4.45 x 5.08 x 3.18 cm)	
2	47301GT	PIN,1.75DIA X 26.71LG,2RING.....9 (67.84 x 4.445 cm)	
3	39127GT	WASHER,SCIS ARM,1.79X2.25X.120.....22	
4	18384GT	SNAP RING,EXTERNAL,1.75 DIA.....22	
5	47302GT	PIN,1.75DIA X 8.51LG,2RING.....2 (21.62 x 4.445 cm)	
6	4828GT	NUT,NYLOCK,3/8-16.....4	
7	14033GT	SCREW,HHC,3/8-16 X 2.75.....4	
8	39095GT	PIN,1.75DIA X 7.35LG,CHAMFER.....2 (18.77 x 4.445 cm)	
9	47510GT	SLIDER,BASE CHASSIS,46.....2	
10	48344GT	ARM-#1 INNER W/DECALS GS2646....1 (includes 4 each item 1)	
11	51763GT	BEARING,FL,1.75IDX2.25ODX.85L.....2 (4.45 x 5.08 x 6.35 cm)	
12	47102GT	PIN,1.75DIA X 7.94LG, 1HOLE.....2 (20.17 x 4.445 cm)	
13	48345GT	ARM-#1 OUTER W/BEARINGS GS2646.....1 (includes 8 each item 1)	
14	48346GT	ARM-#2 INNER W/BEARINGS,GS2646.....1 (includes 8 each item 1)	
15	48349GT	ARM-#3 OUTER W/BEARING GS2646...2 (battery pack side) (includes 6 each item 1)	
16	48347GT	ARM-#2 OUTER W/BEARINGS GS2646.....2 (ground controls side) (includes 6 each item 1)	
17	48348GT	ARM-#3 INNER W/BEARINGS,GS2646.....1 (includes 6 each item 1)	
18	48350GT	ARM-#4 INNER W/BEARINGS,GS2646.....1 (includes 4 each item 1)	
19	48351GT	ARM-#4 OUTER W/BEARING GS2646...1 (includes 8 each item 1)	

304.1 Scissor Assembly, GS-2646, View 2 (to SN 23567)

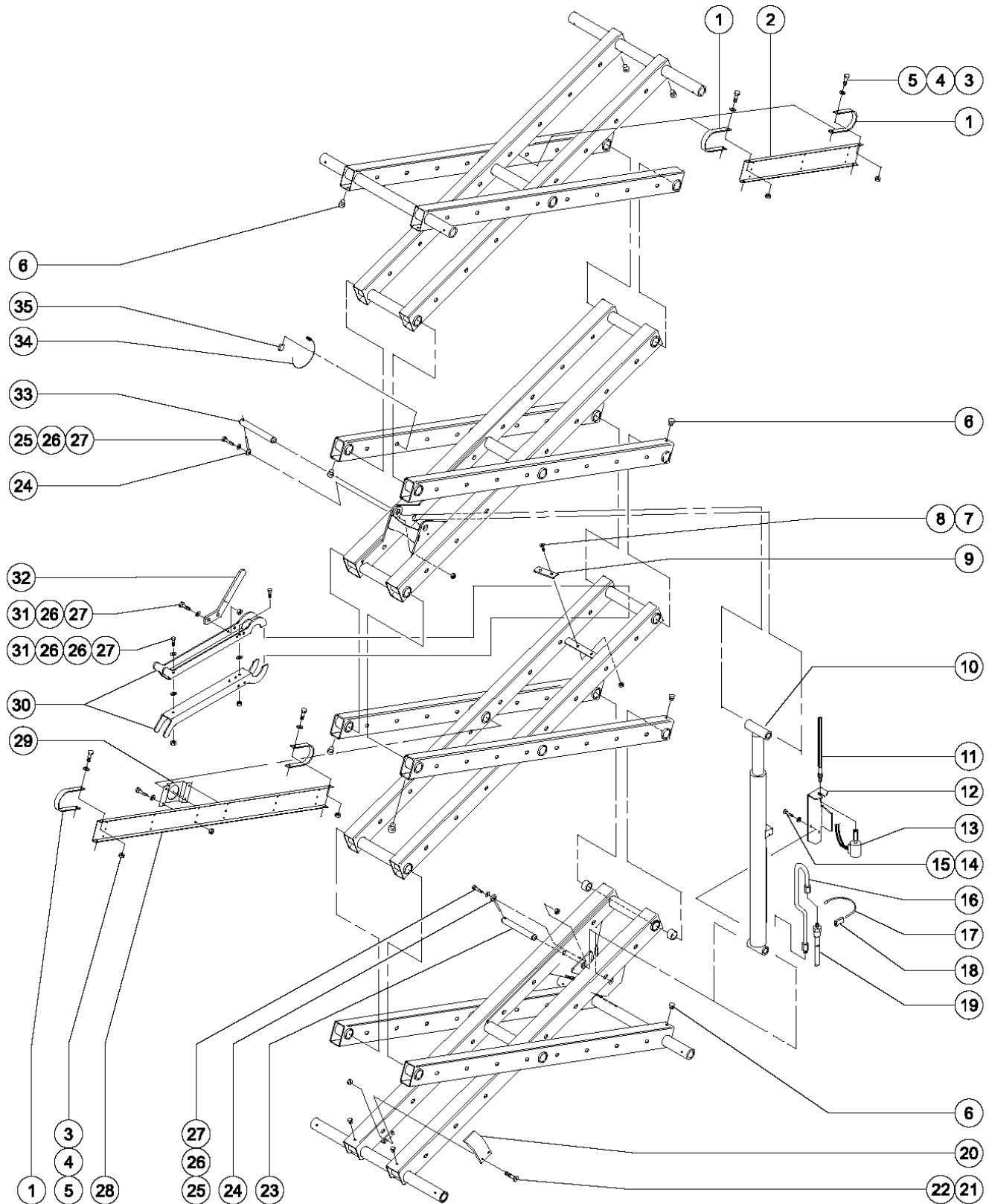

304.1 Scissor Assembly, GS-2646, View 2 (to SN 23567)

Item	Part No.	Description	Qty.	Item	Part No.	Description	Qty.
1	55351GT	CLAMP, CABLEBRIDGE,HALF.....8 <i>(older strap shown)</i>	8	27	4828GT	NUT,NYLOCK,3/8-16.....6	6
2	78687GT	FORMING, CABLE BRIDGE, UPPER.....1	1	28	78686GT	FORMING,CABLE BRIDGE,MAIN***.....1	1
3	8914GT	SCREW, HHC, 1/4-20 X .625.....20	20	29	47625GT	BRACKET CABLE BRIDGE.....1	1
4	6638GT	WASHER,FLAT,USS,1/4"Y.....20	20	30	58000GT	SAFETY CHOCK,SCISSOR.....1 <i>(includes item 32, 4 each item 26, and 2 each items 27, 31)</i>	1
5	6091GT	NUT,NYLOCK,1/4-20.....20	20	31	6175GT	SCREW,HHC,3/8-16 X 1.....4	4
6	47502GT	BUMPER,1.25 INCH O.D.,SCISSORS.....16 <i>(3.2 cm)</i>	16	32	52356GT	HANDLE ASSY,SEE58000-S/58001-S....1	1
7	16439GT	SCREW,FHS,3/8-16 X 1.....2	2	--	44733GT	HANDLE COVER,PLASTIC.....1	1
8	7713GT	NUT, LP NYLOCK, 3/8-16.....2	2	33	47955GT	PIN,1.50DIAX10.45LG,1HOLE.....1 <i>(26.54 x 3.81 cm)</i>	1
9	51424GT	PAD,BUMPER SUPPORT.....1 <i>(18.42 x 3.86 x 0.953 cm)</i>	1	34	21121GT	CABLE TIE,4" BLK,HEAT RESISTNT....20 <i>(10.2 cm) (quantities vary)</i>	20
10	58128GT	CYL.UPDATE GS-3246,3268.....1 <i>(includes orifice, spring and fitting)</i>	1	35	39560GT	CLIP,CABLE TIE MOUNT.....20 <i>(quantities vary)</i>	20
--	39878GT	CONNECTOR,070120-6-6.....1	1				
--	45071GT	BEARING,1.5IDX1.75ODX1.5L.....1 <i>(3.81 x 4.45 x 3.81 cm)</i>	1				
--	48340GT	SEAL KIT, 48341 LIFT CYL.....1	1				
--	55560GT	ORIFICE,LONG, .059".....1 <i>(1.499 mm)</i>	1				
11		Ref. Cable - Manual Platform Lowering...1 <i>(refer to Figure 202.1 or 202.2 )</i>	1				
12	41557-SGT	CABLE BRACKET,PAINTED.....1	1				
13	66465GT	VALVE,W/20V NC SOLENOID,MANUAL.....1	1				
--	44973GT	NUT,COIL (39909).....1	1				
--	44979GT	SEAL KIT,39909,PLAT LWR VALVE*.....1	1				
--	84422GT	COIL-SOLENOID VALVE,20V DC***.....1 <i>(direct replacement for 44787)</i>	1				
14	7339GT	SCREW, HHC, 1/4-20 X .5.....2	2				
15	6356GT	WASHER, LOCK, .25.....2	2				
16	47012GT	FLARE TUBE ASSY,LIFT CYLINDER.....1	1				
17	28443GT	CABLE TIE,11.5" BLACK.....1 <i>(29.2 cm)</i>	1				
18	47046GT	CABLE TIE MOUNT.....1	1				
19		Ref. Hydraulic Hoses and Fittings.....1 <i>(refer to Figure 213.1)</i>	1				
20	47566GT	PLATE,LIFT ARM CAM 1930,32,46.....1	1				
21	19284GT	SCREW,FHS,1/4-20 X .63.....2	2				
22	6889GT	NUT,LP NYLOCK,1/4-20.....2	2				
23	47458GT	PIN,1.50DIAX8.45LG,1HOLE.....1 <i>(21.46 x 3.81 cm)</i>	1				
24	45226GT	ROD END,.375 X 3.69.....2 <i>(0.953 x 8.26 cm)</i>	2				
25	8516GT	SCREW,HHC,3/8-16 X 1.50,GR5.....2	2				
26	6097GT	WASHER,FLAT,USS,3/8",Y.....8	8				

304.2 Scissor Assembly, GS-2646, View 2 (from SN 23568)

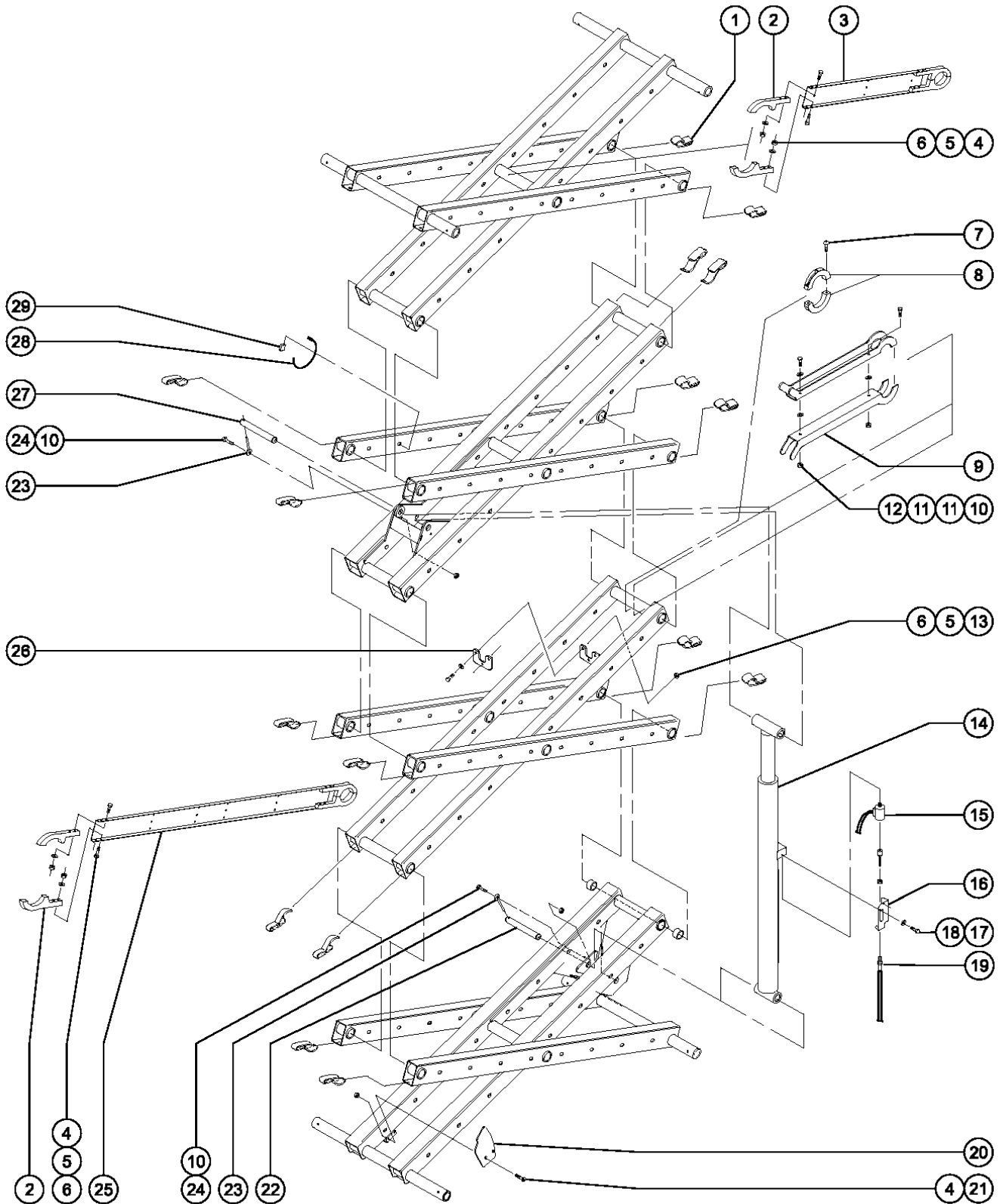

304.2 Scissor Assembly, GS-2646, View 2 (from SN 23568)

Item	Part No.	Description	Qty.	Item	Part No.	Description	Qty.
1	47502GT	BUMPER,1.25 INCH O.D.,SCISSORS....1 <i>(to SN 42999)</i>	1	24	8516GT	SCREW,HHC,3/8-16 X 1.50,GR5.....2	2
1A	71349GT	BUMPER, LINK.....1 <i>(from SN 43000)</i>	1	25	78686GT	FORMING,CABLE BRIDGE,MAIN***.....1	1
2	55351GT	CLAMP, CABLEBRIDGE,HALF.....8	8	26	55336GT	CHOCK STOP CUSHION.....1	1
3	78687GT	FORMING, CABLE BRIDGE, UPPER....1	1	27	47955GT	PIN,1.50DIAX10.45LG,1HOLE.....1 <i>(26.54 x 3.81 cm)</i>	1
4	6889GT	NUT,LP NYLOCK,1/4-20.....18	18	28	21121GT	CABLE TIE,4" BLK,HEAT RESISTNT....26 <i>(10.2 cm) (quantities vary)</i>	26
5	6638GT	WASHER,FLAT,USS,1/4"Y.....19	19	29	39560GT	CLIP,CABLE TIE MOUNT.....26 <i>(quantities vary)</i>	26
6	6888GT	SCREW,HHC,1/4-20 X 1.....19	19				
7	11966GT	SCREW,BHHS,1/4-20 X 1.5.....1	1				
8	55488GT	CROSS TUBE COLAR, GS46\68.....2 <i>(includes nut fastener)</i>	2				
9	58000GT	SAFETY CHOCK,SCISSOR.....1 <i>(includes 2 each item 10 and items 11 and 12)</i>	1				
10	4828GT	NUT,NYLOCK,3/8-16.....4	4				
11	6097GT	WASHER,FLAT,USS,3/8",Y.....4	4				
12	6019GT	SCREW,HHC,3/8-16 X 1.25 GRD 5.....2	2				
13	6091GT	NUT,NYLOCK,1/4-20.....3	3				
14	55717GT	CYLINDER, GS2632/46/68***.....1 <i>(includes orifice and fitting)</i>	1				
--	39878GT	CONNECTOR,070120-6-6.....1	1				
--	45071GT	BEARING,1.5IDX1.75ODX1.5L.....1 <i>(3.81 x 4.45 x 3.81 cm)</i>	1				
--	55560GT	ORIFICE,LONG, .059".....1 <i>(1.499 mm)</i>	1				
--	66470GT	SEAL KIT (55717) TEXAS HYD VER....1 <i>(Texas)</i>	1				
--	78912GT	SEAL KIT, 55717 DY LIFTCYL.....1 <i>(Dongyang)</i>	1				
15	66465GT	VALVE,W/20V NC SOLENOID,MANUAL.....1 <i>(from SN 28933)</i>	1				
--	44973GT	NUT,COIL (39909).....1	1				
--	44979GT	SEAL KIT,39909,PLAT LWR VALVE*.....1	1				
--	84422GT	COIL-SOLENOID VALVE,20V DC***.....1 <i>(direct replacement for 66767)</i>	1				
16	41557-SGT	CABLE BRACKET,PAINTED.....1	1				
17	7339GT	SCREW, HHC, 1/4-20 X .5.....1	1				
18	6356GT	WASHER, LOCK, .25.....1	1				
19		Ref. Cable - Manual Platform Lowering...1 <i>(refer to Figure 202.2)</i>	1				
20	51596GT	PLATE,LIFT ARM CAM,GS-3246.....1	1				
21	8914GT	SCREW, HHC, 1/4-20 X .625.....2	2				
22	47666GT	PIN,1.50DIAX9.13LG,1HOLE.....1 <i>(22.73 x 3.81 cm)</i>	1				
23	45226GT	ROD END,.375 X 3.69.....2 <i>(0.953 x 8.26 cm)</i>	2				



305.1 Scissor Assembly, GS-3246, View 1 (to SN 23567)

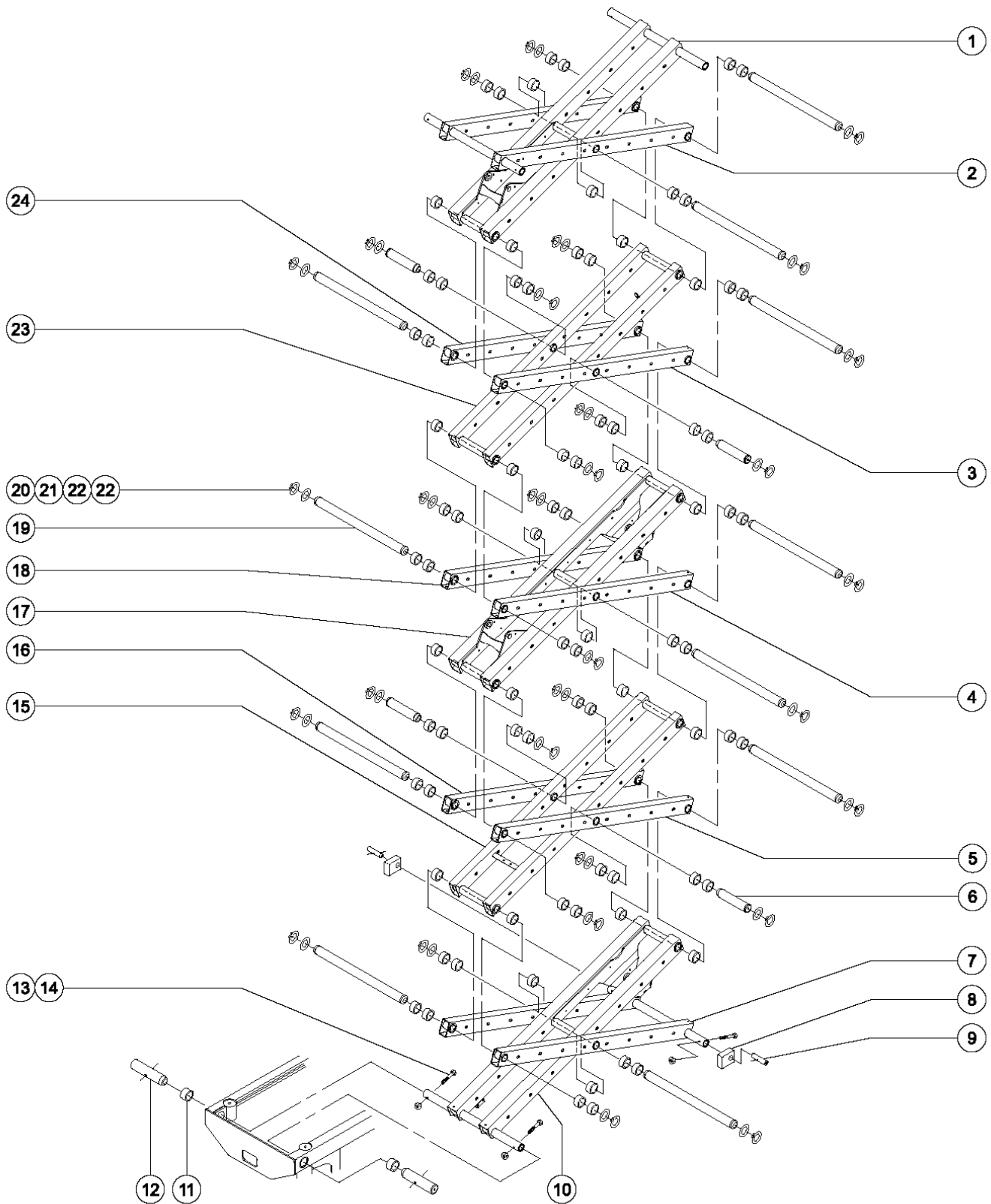

305.1 Scissor Assembly, GS-3246, View 1 (to SN 23567)

Item	Part No.	Description	Qty.	Item	Part No.	Description	Qty.
1	52326GT	ARM-#5 INNER W/BEARINGS,GS3246.....1 <i>(includes 4 each item 22)</i>	1	24	52328GT	ARM-#4 OUTR,GRN.CONTROL,GS3246.....1 <i>(ground controls side) (includes 6 each item 22)</i>	1
2	48351GT	ARM-#4 OUTER W/BEARING GS2646...1 <i>(includes 8 each item 22)</i>	1				
3	52327GT	ARM-#4 OUTR,BATT.SIDE, GS3246.....1 <i>(battery pack side) (includes 6 each item 22)</i>	1				
4	52330GT	ARM-#3 OUTR,BATT.SIDE, GS3246.....1 <i>(battery pack side) (includes 6 each item 22)</i>	1				
5	48349GT	ARM-#3 OUTER W/BEARING GS2646...1 <i>(battery pack side) (includes 6 each item 22)</i>	1				
6	47302GT	PIN,1.75DIAx8.51LG,2RING.....4 <i>(21.62 x 4.445 cm)</i>	4				
7	48345GT	ARM-#1 OUTER W/BEARINGS GS2646.....1 <i>(includes 8 each item 22)</i>	1				
8	47510GT	SLIDER,BASE CHASSIS,46.....2	2				
9	39095GT	PIN,1.75DIAx7.35LG,CHAMFER.....2 <i>(18.77 x 4.445 cm)</i>	2				
10	48344GT	ARM-#1 INNER W/DECALS GS2646.....1 <i>(includes 4 each item 22)</i>	1				
11	51763GT	BEARING,FL,1.75IDX2.25ODX.85L.....2 <i>(4.45 x 5.08 x 6.35 cm)</i>	2				
12	47102GT	PIN,1.75DIA.X7.94LG, 1HOLE.....2 <i>(20.17 x 4.445 cm)</i>	2				
13	14033GT	SCREW,HHC,3/8-16 X 2.75.....4	4				
14	4828GT	NUT,NYLOCK,3/8-16.....4	4				
15	48346GT	ARM-#2 INNER W/BEARINGS,GS2646.....1 <i>(includes 8 each item 22)</i>	1				
16	48347GT	ARM-#2 OUTER W/BEARINGS GS2646.....1 <i>(ground controls side) (includes 6 each item 22)</i>	1				
17	52332GT	ARM-#3 INNER W/BEARINGS,GS3246.....1 <i>(includes 6 each item 22)</i>	1				
18	52331GT	ARM-#3 OUTR,GRN.CONTROL,GS3246.....1 <i>(ground controls side) (includes 6 each item 22)</i>	1				
19	47301GT	PIN,1.75DIAx26.71LG,2RING.....11 <i>(67.84 x 4.445 cm)</i>	11				
20	18384GT	SNAP RING,EXTERNAL,1.75 DIA.....22	22				
21	39127GT	WASHER,SCIS ARM,1.79X2.25X.120.....30	30				
22	51144GT	BEARING,1.75IDX2.00ODX1.25L.....82 <i>(4.45 x 5.08 x 3.18 cm)</i>	82				
23	52329GT	ARM-#4 INNER, GS3246.....1 <i>(includes 8 each item 22)</i>	1				



305.2 Scissor Assembly, GS-3246, View 1 (from SN 23568)

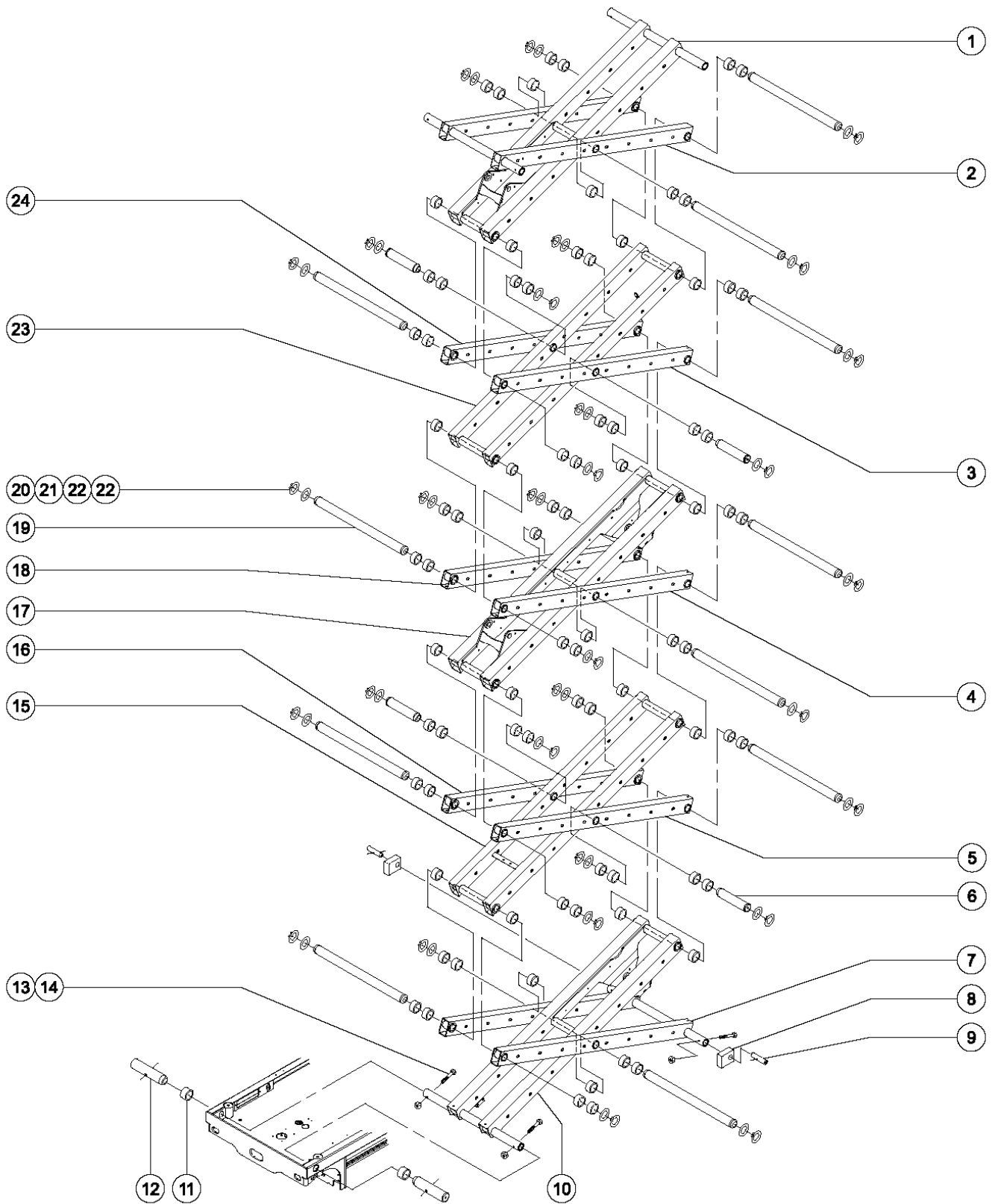



305.2 Scissor Assembly, GS-3246, View 1 (from SN 23568)

Item	Part No.	Description	Qty.	Item	Part No.	Description	Qty.
1	52326GT	ARM-#5 INNER W/BEARINGS,GS3246.....1 <i>(includes 4 each item 22)</i>	1	24	52328GT	ARM-#4 OUTR,GRN.CONTROL,GS3246.....1 <i>(ground controls side) (includes 6 each item 22)</i>	1
2	48351GT	ARM-#4 OUTER W/BEARING GS2646...1 <i>(includes 8 each item 22)</i>	1				
3	52327GT	ARM-#4 OUTR,BATT.SIDE, GS3246.....1 <i>(battery pack side) (includes 6 each item 22)</i>	1				
4	52330GT	ARM-#3 OUTR,BATT.SIDE, GS3246.....1 <i>(battery pack side) (includes 6 each item 22)</i>	1				
5	65993GT	ARM-SINGLE OUTER, LEFT.....1 <i>(battery pack side) (includes 6 each item 22)</i>	1				
6	47302GT	PIN,1.75DIAx8.51LG,2RING.....4 <i>(21.62 x 4.445 cm)</i>	4				
7	48345GT	ARM-#1 OUTER W/BEARINGS GS2646.....1 <i>(includes 8 each item 22)</i>	1				
8	47510GT	SLIDER,BASE CHASSIS,46.....2	2				
9	39095GT	PIN,1.75DIAx7.35LG,CHAMFER.....2 <i>(18.77 x 4.445 cm)</i>	2				
10	48344GT	ARM-#1 INNER W/DECALS GS2646.....1 <i>(includes 4 each item 22)</i>	1				
11	51763GT	BEARING,FL,1.75IDX2.25ODX.85L.....2 <i>(4.45 x 5.08 x 6.35 cm)</i>	2				
12	47102GT	PIN,1.75DIA.X7.94LG, 1HOLE.....2 <i>(20.17 x 4.445 cm)</i>	2				
13	14033GT	SCREW,HHC,3/8-16 X 2.75.....4	4				
14	4828GT	NUT,NYLOCK,3/8-16.....4	4				
15	62210GT	ARM-#4 INNER W/BEARING,GS3268....1 <i>(includes 8 each item 22)</i>	1				
16	52364GT	ARM-#3 OUTR,ENGINE SIDE,GS68....1 <i>(ground controls side) (includes 6 each item 22)</i>	1				
17	52332GT	ARM-#3 INNER W/BEARINGS,GS3246.....1 <i>(includes 6 each item 22)</i>	1				
18	52331GT	ARM-#3 OUTR,GRN.CONTROL,GS3246.....1 <i>(ground controls side) (includes 6 each item 22)</i>	1				
19	47301GT	PIN,1.75DIAx26.71LG,2RING.....11 <i>(67.84 x 4.445 cm)</i>	11				
20	18384GT	SNAP RING,EXTERNAL,1.75 DIA.....22	22				
21	39127GT	WASHER,SCIS ARM,1.79X2.25X.120.....30	30				
22	51144GT	BEARING,1.75IDX2.00ODX1.25L.....82 <i>(4.45 x 5.08 x 3.18 cm)</i>	82				
23	52329GT	ARM-#4 INNER, GS3246.....1 <i>(includes 8 each item 22)</i>	1				

306.1 Scissor Assembly, GS-3246, View 2 (to SN 23567)

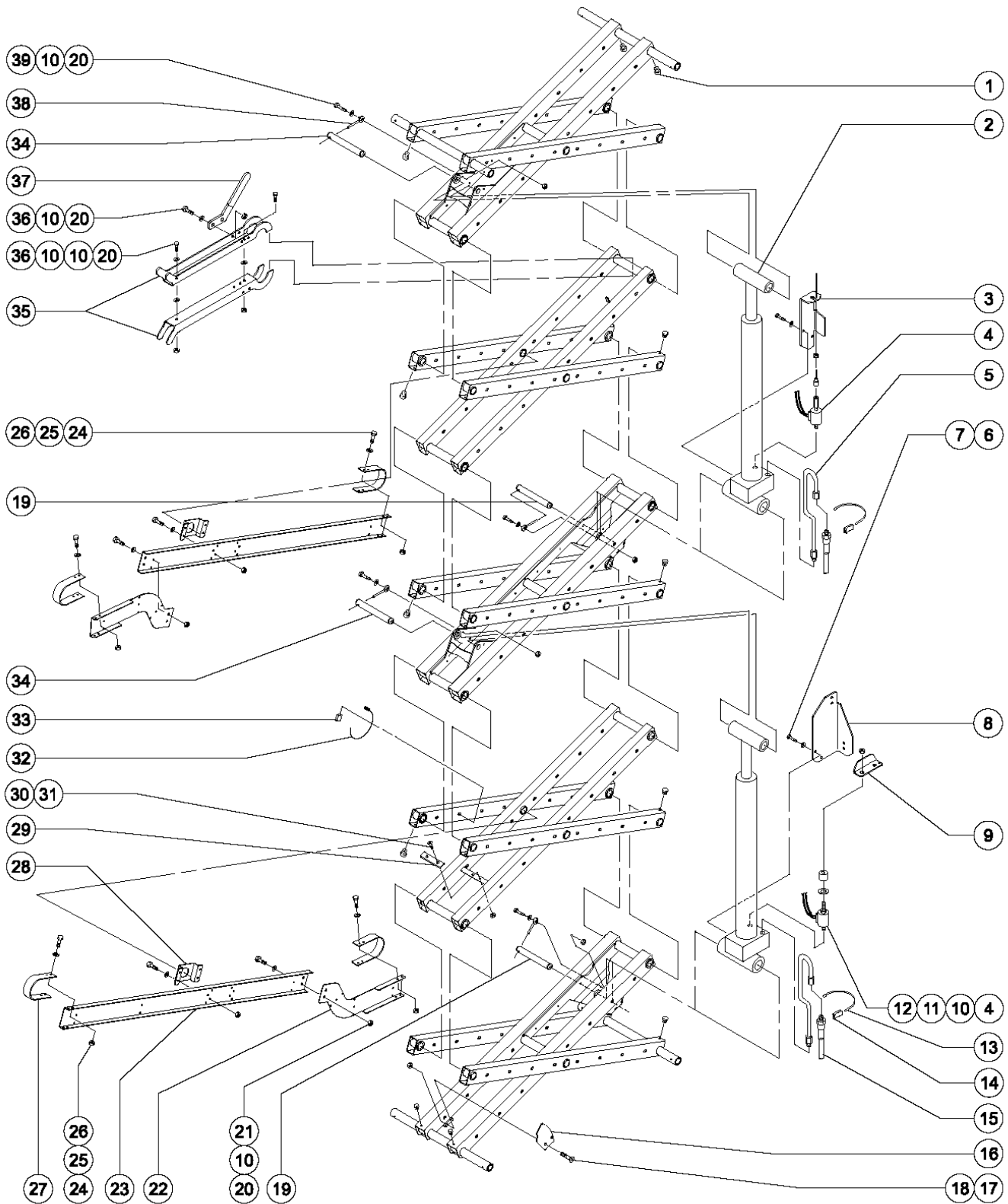

306.1 Scissor Assembly, GS-3246, View 2 (to SN 23567)

Item	Part No.	Description	Qty.	Item	Part No.	Description	Qty.
1	47502GT	BUMPER,1.25 INCH O.D.,SCISSORS.....20 (3.2 cm)	20	30	16439GT	SCREW,FHS,3/8-16 X 1.....2	2
2	58128GT	CYL.UPDATE GS-3246,3268.....2 (includes orifice and fitting)	2	31	7713GT	NUT, LP NYLOCK, 3/8-16.....2	2
--	39878GT	CONNECTOR,070120-6-6.....2	2	32	21121GT	CABLE TIE,4" BLK,HEAT RESISTNT....20 (10.2 cm) (quantities vary)	20
--	45071GT	BEARING,1.5IDX1.75ODX1.5L.....2 (3.81 x 4.45 x 3.81 cm)	2	33	39560GT	CLIP,CABLE TIE MOUNT.....20 (quantities vary)	20
--	55560GT	ORIFICE,LONG, .059".....2 (1.499 mm)	2	34	47955GT	PIN,1.50DIAX10.45LG,1HOLE.....2 (26.54 x 3.81 cm)	2
3	41557-SGT	CABLE BRACKET,PAINTED.....1	1	35	58001GT	SAFETY CHOCK-SCISSOR.....1 (includes 6 each item 10, 4 each item 20 and items 36 and 37)	1
4	66465GT	VALVE,W/20V NC SOLENOID,MANUAL.....2	2	36	6175GT	SCREW,HHC,3/8-16 X 1.....4	4
--	44973GT	NUT,COIL (39909).....2	2	37	52356GT	HANDLE ASSY,SEE58000-S/58001-S....1	1
--	44979GT	SEAL KIT,39909,PLAT LWR VALVE*.....2	2	--	44733GT	HANDLE COVER,PLASTIC.....1	1
--	84422GT	COIL-SOLENOID VALVE,20V DC***.....2 (direct replacement for 44787)	2	38	45226GT	ROD END,.375 X 3.69.....4 (0.953 x 8.26 cm)	4
5	47012GT	FLARE TUBE ASSY,LIFT CYLINDER....2	2	39	8516GT	SCREW,HHC,3/8-16 X 1.50,GR5.....4	4
6	7339GT	SCREW, HHC, 1/4-20 X .5.....4	4				
7	6356GT	WASHER, LOCK, .25.....4	4				
8	51582GT	CABLE BRACKET,VERTICAL.....1	1				
9	51584GT	CABLE BRACKET,YOKE.....1	1				
10	6097GT	WASHER,FLAT,USS,3/8",Y.....15	15				
11	51638GT	SPACER,EMERGENCY DOWN.....1	1				
12	4828GT	NUT,NYLOCK,3/8-16.....1	1				
13	28443GT	CABLE TIE,11.5" BLACK.....2 (29.2 cm)	2				
14	47046GT	CABLE TIE MOUNT.....2	2				
15		Ref. Hydraulic Hoses and Fittings.....2 (refer to Figure 213.1)	2				
16	51596GT	PLATE,LIFT ARM CAM,GS-3246.....1	1				
17	19284GT	SCREW,FHS,1/4-20 X .63.....2	2				
18	6889GT	NUT,LP NYLOCK,1/4-20.....2	2				
19	47458GT	PIN,1.50DIAX8.45LG,1HOLE.....2 (21.46 x 3.81 cm)	2				
20	4828GT	NUT,NYLOCK,3/8-16.....12	12				
21	8255GT	SCREW, HHC, 3/8-16 X .75.....4	4				
22	51542GT	BRACKET,CABLE BRIDGE,GS3246.....2	2				
23	51505GT	BRACKET,MAIN CABLE BRIDGE.....2	2				
24	6091GT	NUT,NYLOCK,1/4-20.....28	28				
25	6638GT	WASHER,FLAT,USS,1/4"Y.....24	24				
26	8914GT	SCREW, HHC, 1/4-20 X .625.....24	24				
27	55351GT	CLAMP, CABLEBRIDGE,HALF.....8 (older strap shown)	8				
28	47625GT	BRACKET CABLE BRIDGE.....2	2				
29	51424GT	PAD,BUMPER SUPPORT.....1 (18.42 x 3.86 x 0.953 cm)	1				



306.2 Scissor Assembly, GS-3246, View 2 (from SN 23568)

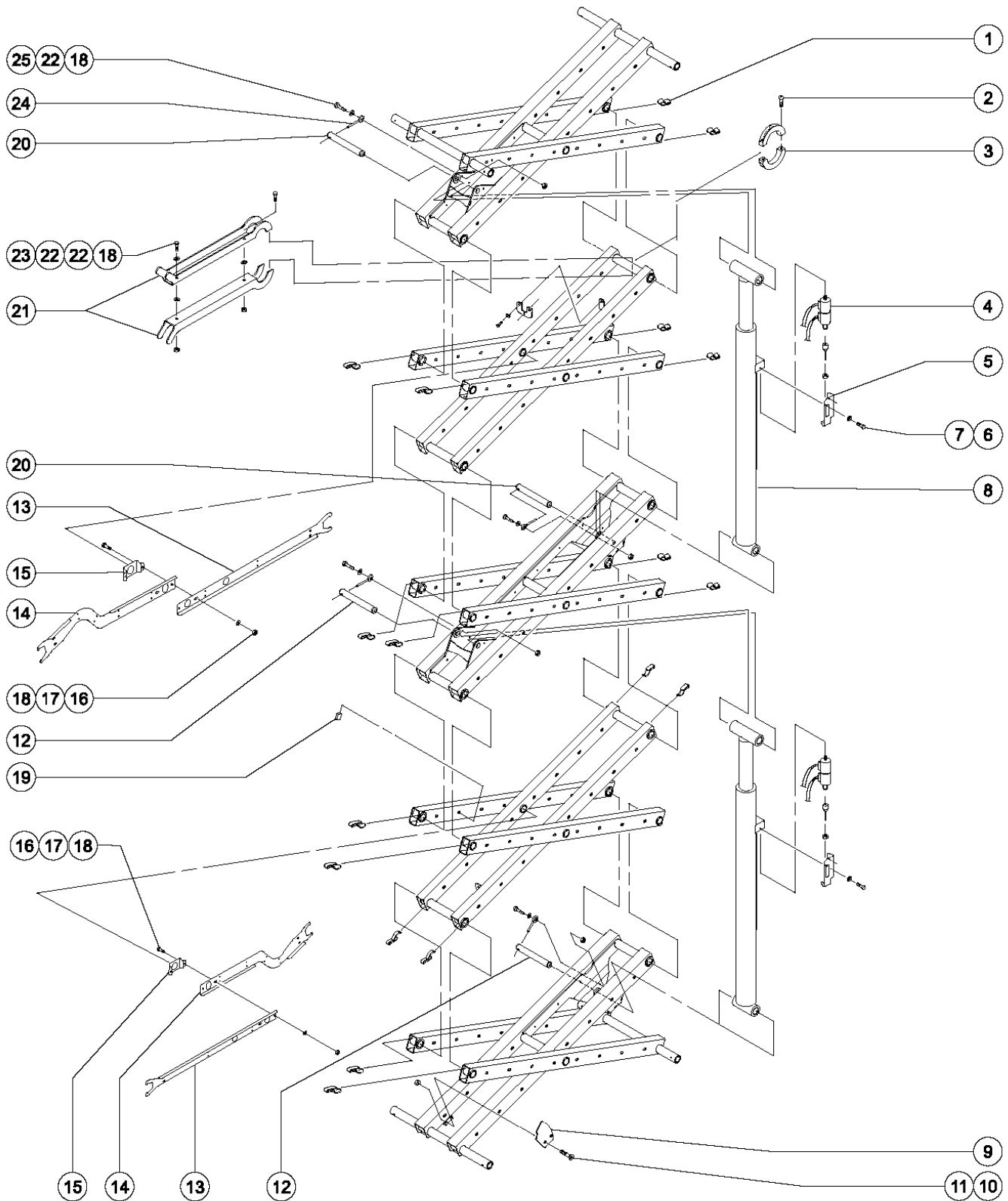

306.2 Scissor Assembly, GS-3246, View 2 (from SN 23568)

Item	Part No.	Description	Qty.	Item	Part No.	Description	Qty.
--				15	78897GT	FORMING, CABLE BRIDGE, CENTER...	2
1	47502GT	BUMPER, 1.25 INCH O.D., SCISSORS... <i>(to SN 42999)</i>	2	16	6175GT	SCREW, HHC, 3/8-16 X 1.....	4
1A	71349GT	BUMPER, LINK..... <i>(from SN 43000)</i>	2	17	5397GT	WASHER, FLAT, USS, 5/16", Y.....	2
2	11966GT	SCREW, BHHS, 1/4-20 X 1.5..... <i>(includes nut fastener)</i>	1	18	4828GT	NUT, NYLOCK, 3/8-16.....	14
3	55488GT	CROSS TUBE COLAR, GS46\68.....	2	19	39560GT	CLIP, CABLE TIE MOUNT..... <i>(quantities vary)</i>	26
4	66465GT	VALVE, W/20V NC SOLENOID, MANUAL..... <i>(to SN 27182)</i>	2	20	47955GT	PIN, 1.50DIAX10.45LG, 1HOLE..... <i>(26.54 x 3.81 cm)</i>	2
--	44973GT	NUT, COIL (39909)..... <i>(to SN 27182)</i>	2	21	58001GT	SAFETY CHOCK-SCISSOR..... <i>includes 2 each index number 10 and 16 and 4 each index number 22</i>	1
--	44979GT	SEAL KIT, 39909, PLAT LWR VALVE*..... <i>(to SN 27182)</i>	2	22	6097GT	WASHER, FLAT, USS, 3/8", Y.....	10
--	84422GT	COIL-SOLENOID VALVE, 20V DC***..... <i>(to SN 27182) (direct replacement for 66467)</i>	2	23	6019GT	SCREW, HHC, 3/8-16 X 1.25 GRD 5.....	2
4A	66683GT	VALVE, DBL PULL S-NOID 20V***..... <i>(from SN 27183)</i>	2	24	6888GT	SCREW, HHC, 1/4-20 X 1.....	19
--	44973GT	NUT, COIL (39909)..... <i>(from SN 27183)</i>	2	25	45226GT	ROD END, .375 X 3.69..... <i>(0.953 x 8.26 cm)</i>	2
--	44979GT	SEAL KIT, 39909, PLAT LWR VALVE*..... <i>(from SN 27183)</i>	2				
--	84422GT	COIL-SOLENOID VALVE, 20V DC***..... <i>(from SN 27183)</i>	2				
5	41557-SGT	CABLE BRACKET, PAINTED.....	2				
6	7339GT	SCREW, HHC, 1/4-20 X .5.....	4				
7	6356GT	WASHER, LOCK, .25.....	4				
8	58148GT	CYL. ASSY, 2046-3268..... <i>(includes orifice and fitting)</i>	2				
--	39878GT	CONNECTOR, 070120-6-6.....	2				
--	45071GT	BEARING, 1.5ID X 1.75OD X 1.5L..... <i>(3.81 x 4.45 x 3.81 cm)</i>	2				
--	55560GT	ORIFICE, LONG, .059"..... <i>(1.499 mm)</i>	2				
--	66470GT	SEAL KIT (55717) TEXAS HYD VER					
9	51596GT	PLATE, LIFT ARM CAM, GS-3246.....	1				
10	19284GT	SCREW, FHS, 1/4-20 X .63.....	2				
11	6889GT	NUT, LP NYLOCK, 1/4-20.....	18				
12	47458GT	PIN, 1.50DIAX8.45LG, 1HOLE.....	2				
13	78686GT	FORMING, CABLE BRIDGE, MAIN***.....	2				
--	78900GT	TRIM LOCK, 1/8 X .75..... <i>(5.72 cm)</i>	2.25-inches				
14	78688GT	FORMING, CABLE BRIDGE, GS3246/68..... <i>(from SN 23568 to 47403)</i>	2				
--	78900GT	TRIM LOCK, 1/8 X .75..... <i>(5.72 cm)</i>	2.25-inches				



401.1 Platform Installation

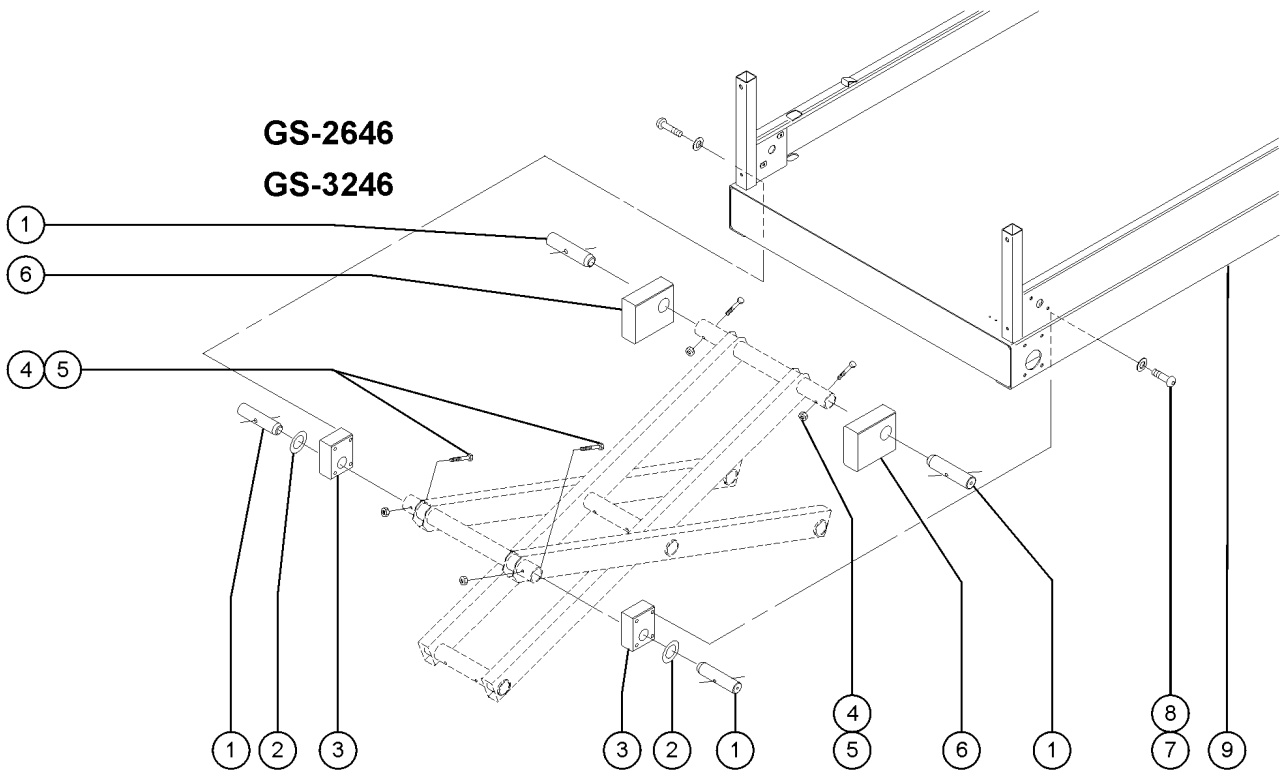
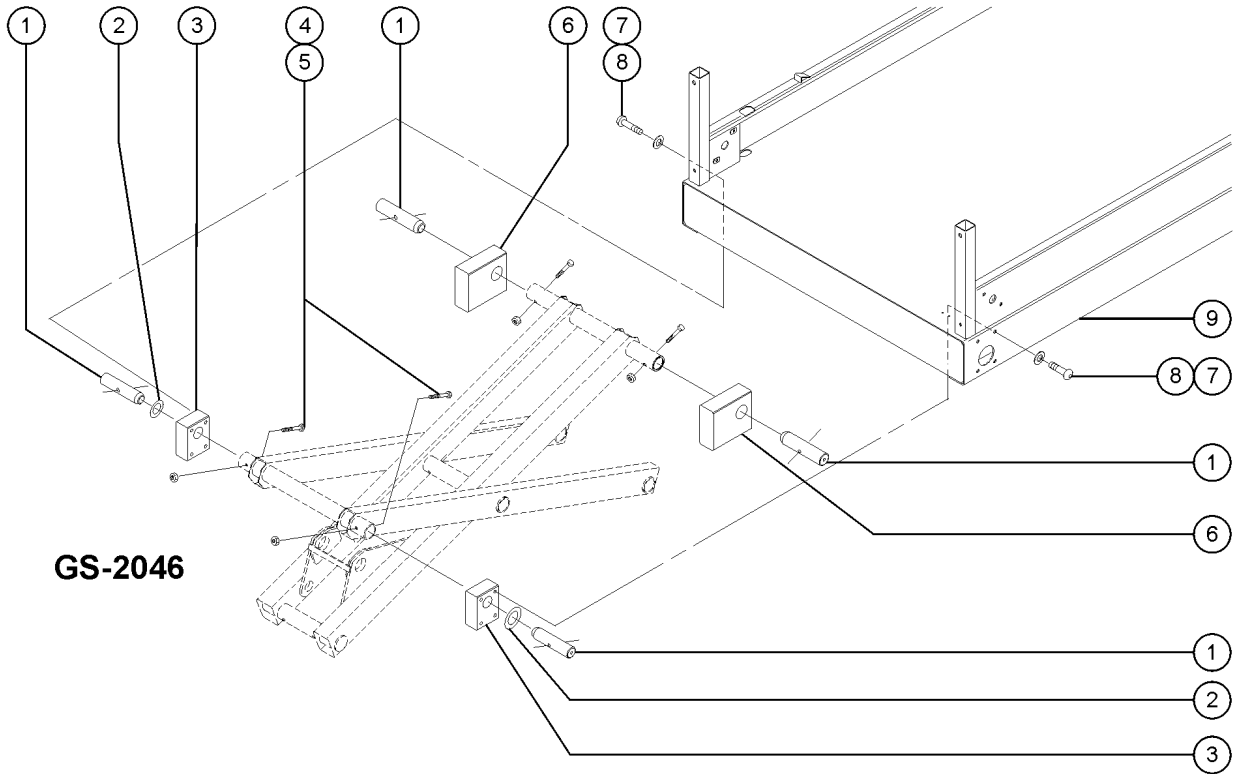

Item	Part No.	Description	Qty.
1	39095GT	PIN,1.75DIAX7.35LG,CHAMFER.....4 <i>(18.77 x 4.445 cm)</i>	4
2	39127GT	WASHER,SCIS ARM,1.79X2.25X.120....4	4
3	47160GT	BLOCK, PLATFORM ANCHOR.....2 <i>(10.8 x 6 x 14.6 cm)</i>	2
4	14033GT	SCREW,HHC,3/8-16 X 2.75.....4	4
5	4828GT	NUT,NYLOCK,3/8-16.....4	4
6	131426GT	SLIDER BLOCK,PLATFORM.....2 <i>(6.5 x 5.77 x 2.38 inches) (16.51 x 14.65 x 6.04 cm)</i>	2
7	36874GT	SCREW,BHHS,3/8-16 X 2.5.....8	8
8	6021GT	WASHER, LOCK, .375.....8	8
9		Ref. Platform Assembly.....1 <i>(refer to Figure 402.1, 402.2 or 402.3)</i>	1

402.1 Platform Railings and Entry Gate - Rigid Rails (to SN 42999)

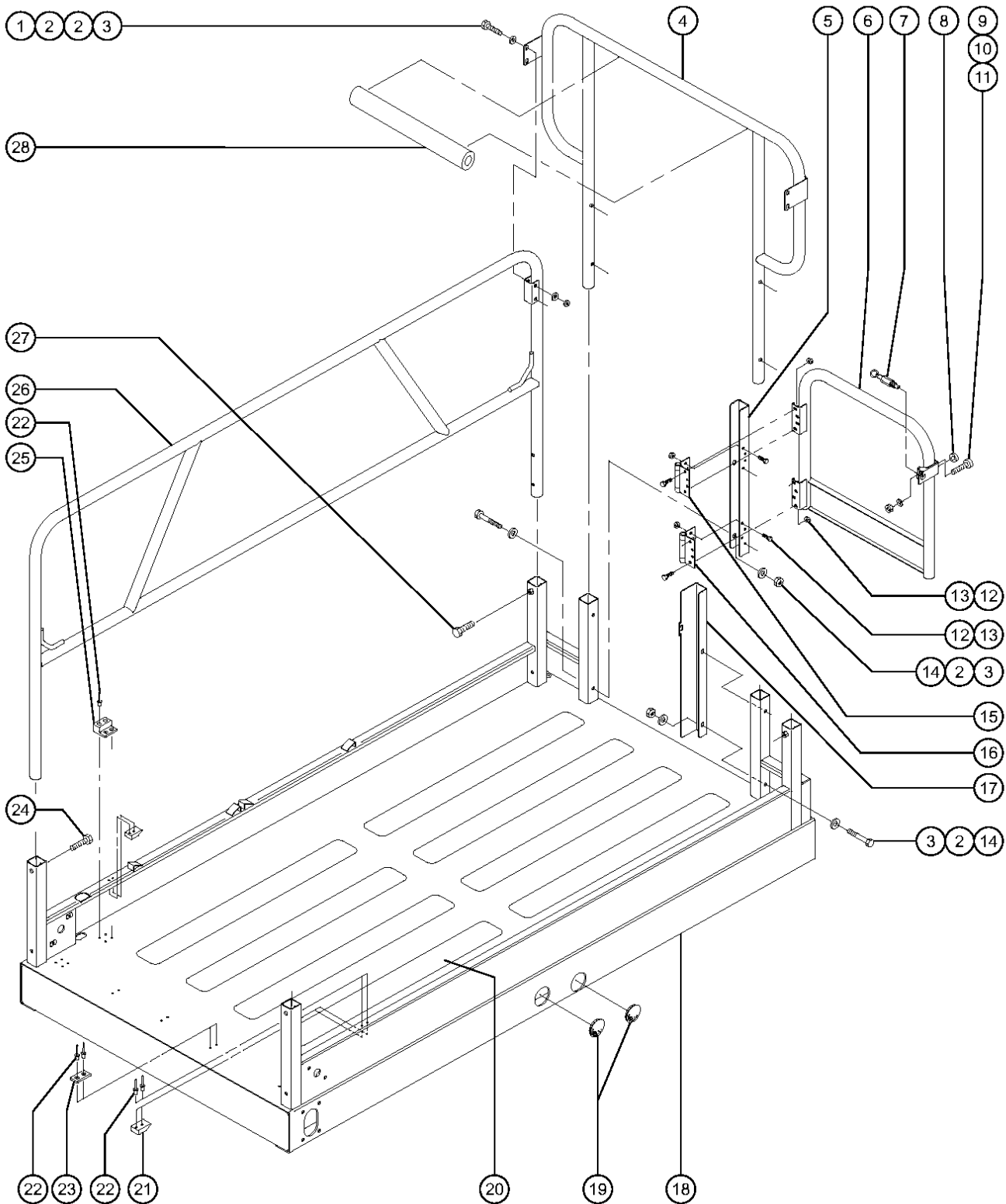



402.1 Platform Railings and Entry Gate - Rigid Rails (to SN 42999)

Item	Part No.	Description	Qty.	Item	Part No.	Description	Qty.
--	52397GT	PLATFORM ASSY W/ DECALS,GS2046 (ANSI, CSA) (complete)		--	97033GT	PLAT.ASSY.W/DECAL CE/AUS.....1 GS-3246 (CE) (includes items 19-23 and 25)	
--	52398GT	PLATFORM ASSY DECALS GS2046 CE (CE) (complete)		19	45840GT	PLUG,NYLON 2.00 BLACK DOMED.....4 (2 inches) (5.1 cm)	
--	48353GT	PLAT. ASSY. W/DECALS (GS2646) (ANSI, CSA) (complete)		20	47098GT	TAPE,NON-SKID,DIE CUT,4"X 40".....8 (10.2 x 101.6 cm)	
--	82100-SGT	GS46 PLAT W/EXT COMPLETE*** GS-2646 (CE)		21	39317GT	STOP PLATFORM ROLLER.....2 (1.63 inches x 1 inch) (4.14 x 2.5 cm)	
--	52399GT	PLATFORM ASSY DECALS GS-3246 (ANSI, CSA) (complete)		22	39579GT	RIVET,STL,STL,.188 X .45.....26	
--	52400GT	PLATFORM ASSY DECALS GS-3246CE (CE) (complete)		23	39474GT	WEAR PAD,PLATFORM.....3 (5.1 x 2.5 x 0.64 cm)	
1	6708GT	SCREW,HHC,3/8-16 X 2.25.....4		24	39478GT	SCREW,HHC,3/8-16 X 2 FULL THRD.....2	
2	6097GT	WASHER,FLAT,USS,3/8",Y.....16		25	39310GT	WEAR/GUIDE PAD MAIN PLATFORM....4	
3	4828GT	NUT,NYLOCK,3/8-16.....8		26	47944GT	WELDMENT,SIDE RAIL.....2	
4	39654GT	PLATFORM GATE WLDMENT GS46"W.....1		27	6019GT	SCREW,HHC,3/8-16 X 1.25 GRD 5.....4	
5	47148GT	BRACKET,HINGE MOUNTING**.....1		28	47188GT	FOAM,CLOSED CELL 1.75X.250X18"....1 (3.5 x 0.64 x 46 cm)	
6	47395GT	WELDMENT,ENTRY GATE 32 **.....1					
7	47138GT	PIN,SNAP,ENTRY RAIL.....1					
8	47785GT	BUMPER,RUBBER,.63 X .63H.....1 (from SN 2394) (16 x 16 mm)					
9	36388GT	BUMPER,RUBBER,.75 X .50H,STUD....1 (to SN 2393)					
10	6356GT	WASHER, LOCK, .25.....1 (to SN 2393)					
11	6357GT	NUT,HEX,1/4-20.....1 (to SN 2393)					
12	6091GT	NUT,NYLOCK,1/4-20.....12					
13	6090GT	SCREW,HHC,1/4-20 X .75.....12					
14	14033GT	SCREW,HHC,3/8-16 X 2.75.....4					
15	47524GT	HINGE,CLOSING (SPRING) 4 X 4.....1					
--	55739GT	SPRING, TORSION, ENTRY GATE.....1					
16	47523GT	HINGE,4 X 4.....1					
17	39608GT	BRACKET,LATCH SUPPORT.....1					
18	97028GT	PLAT.ASSY.W/DECAL ANSI/CSA.....1 GS-2046 (ANSI, CSA) (includes items 19-23 and 25)					
--	97029GT	PLAT.ASSY.W/DECAL CE/AUS.....1 (GS-2046 (CE) (includes items 19-23 and 25)					
--	97030GT	PLAT.ASSY.W/DECAL ANSI/CSA.....1 GS-2646 (ANSI, CSA) (includes items 19-23 and 25)					
--	97031GT	PLAT.ASSY.W/DECAL CE/AUS.....1 GS-2646 (CE) (includes items 19-23 and 25)					
--	97032GT	PLAT.ASSY.W/DECAL ANSI/CSA.....1 GS-3246 (ANSI, CSA) (includes items 19-23 and 25)					



402.2 Platform Railings and Entry Gate - Fold Down Rails, Round Tube (to SN 42999)

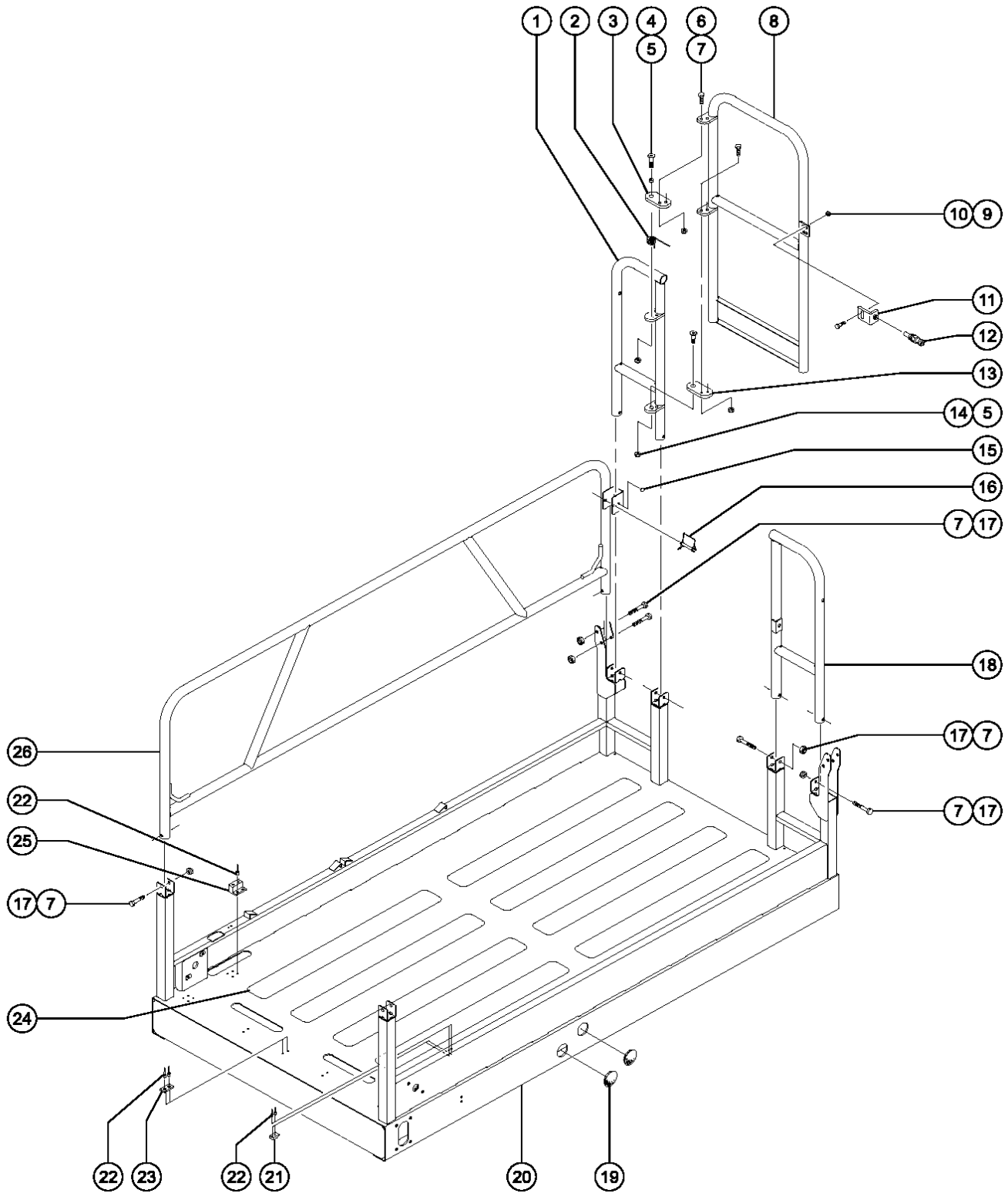

402.2 Platform Railings and Entry Gate - Fold Down Rails, Round Tube (to SN 42999)

Item	Part No.	Description	Qty.	Item	Part No.	Description	Qty.
--	97000GT	PLAT ASSY,FLD/RND,S2046,ANS/CS		--	97146GT	PLAT MAIN ASSY GS2046 AUS.....1 <i>(includes items 19, 21-23 and 25)</i>	
--	97001GT	PLAT ASSY,FLD/RND,S2046, CE		--	97147GT	PLAT MAIN ASSY GS2046 CE.....1 <i>(includes items 19, 21-23 and 25)</i>	
--	97163GT	PLTFRM ASSY COMLT, GS2046AUS		20A	97135GT	PLAT MAIN ASSY W/DECAL 2646ANS.....1 <i>(includes items 19, 21-23 and 25)</i>	
B	97002GT	PLAT ASSY,FLD/RND,S2646,ANS/CS		--	97136GT	PLAT MAIN ASSY W/DECAL 2646AUS.....1 <i>(includes items 19, 21-23 and 25)</i>	
--	97003GT	PLAT ASSY,FLD/RND,S2646, CE		--	97148GT	PLAT MAIN ASSY GS2646 CE.....1 <i>(includes items 19, 21-23 and 25)</i>	
--	97160GT	PLTFRM ASSY GS2646 AUS, ROUND		20B	97137GT	PLAT MAIN ASSY W/DECAL 3246ANS.....1 <i>(includes items 19, 21-23 and 25)</i>	
C	97004GT	PLAT ASSY,FLD/RND,S3246,ANS/CS		--	97138GT	PLAT MAIN ASSY W/DECAL 3246ANS.....1 <i>(includes items 19, 21-23 and 25)</i>	
--	97005GT	PLAT ASSY,FLD/RND,S3246, CE <i>(to SN 24438)</i>		--	97149GT	PLAT MAIN ASSY GS3246 AUS.....1 <i>(includes items 19, 21-23 and 25)</i>	
--	97164GT	PLTFRM ASSY CMPLT, GS3246AUS <i>(to SN 24438)</i>		--	97150GT	PLAT MAIN ASSY GS3246 AUS.....1 <i>(includes items 19, 21-23 and 25)</i>	
--	97165GT	PLTFRM ASSY CMPLT, GS3246AUS <i>(from SN 24439)</i>		--	97151GT	PLAT MAIN ASSY GS3246 CE.....1 <i>(includes items 19, 21-23 and 25)</i>	
--	97169GT	PLTFRM ASSY W/DECAL GS3246 CE <i>(from SN 24439)</i>		--	97152GT	PLAT MAIN ASSY GS3246 CE.....1 <i>(includes items 19, 21-23 and 25)</i>	
1	97024GT	RAIL-SIDE, ENTRY GATE RS***.....1 <i>(ground controls side)</i>		21	39317GT	STOP PLATFORM ROLLER.....2 <i>(4.14 x 2.5 cm)</i>	
2	55739GT	SPRING, TORSION, ENTRY GATE.....1		22	39579GT	RIVET,STL,STL,.188 X .45.....26	
3	97017GT	PLATE ENTRY GATE ASSEMBLY UPPER.....1		23	39474GT	WEAR PAD,PLATFORM.....3 <i>(5.1 x 2.5 x 0.64 cm)</i>	
--	39580GT	BEARING,0.75IDX1.00ODX0.38L.....1 <i>(1.91 x 2.54 x 0.97 cm)</i>		24	47374GT	TAPE,NON-SKID,DIE CUT,4"X 32".....8 <i>(10.2 x 81.3 cm)</i>	
4	71912GT	BOLT,SHOULDER,5/8-11 X 1.19 LT.....1		25	39310GT	WEAR/GUIDE PAD MAIN PLATFORM...4	
5	38028GT	NUT,LP NYLOCK,5/8-11.....2		26	97023GT	RAIL-PLATFORM, FOLDDOWN RS**.....1 <i>(ground controls side) (shown)</i>	
6	6019GT	SCREW,HHC,3/8-16 X 1.25 GRD 5.....4		--	97022GT	RAIL-PLATFORM, FOLDDOWN LS.....1 <i>(battery pack side)</i>	
7	4828GT	NUT,NYLOCK,3/8-16.....13					
8	97019GT	GATE-SWING FOLD DOWN ENT ASSY.....1					
9	7713GT	NUT, LP NYLOCK, 3/8-16.....2					
10	8255GT	SCREW, HHC, 3/8-16 X .75.....2					
11	55898GT	WELDMNT, LATCH, ENTRY GATE.....1					
12	47138GT	PIN,SNAP,ENTRY RAIL.....1					
13	97018GT	PLATE-ENTY GATE ASSEMBLY LOWER.....1					
--	47548GT	BEARING,FL,0.75ID X 1 OD X .49.....1 <i>(0.75 x 1 x 0.38 inch) (1.91 x 2.54 x 0.97 cm)</i>					
14	71912GT	BOLT,SHOULDER,5/8-11 X 1.19 LT.....1					
15	43392GT	BUMPER,BATTERY BOX & RAILS.....2					
16	66030GT	PIN, WIRE LOCK 3/8 X 2 -1/2.....2					
17	8178GT	SCREW,HHC,3/8-16 X 2.5.....10					
18	97021GT	RAIL-SIDE, ENTRY GATE LS.....1 <i>(battery pack side)</i>					
19	45840GT	PLUG,NYLON 2.00 BLACK DOMED.....4 <i>(5.1 cm)</i>					
20	97134GT	PLAT MAIN ASSY GS2046 ANSI CSA....1 <i>(includes items 19, 21-23 and 25)</i>					

402.3 Platform Railings and Entry Gate - Fold Down Rails, Square Tube (from SN 23568)

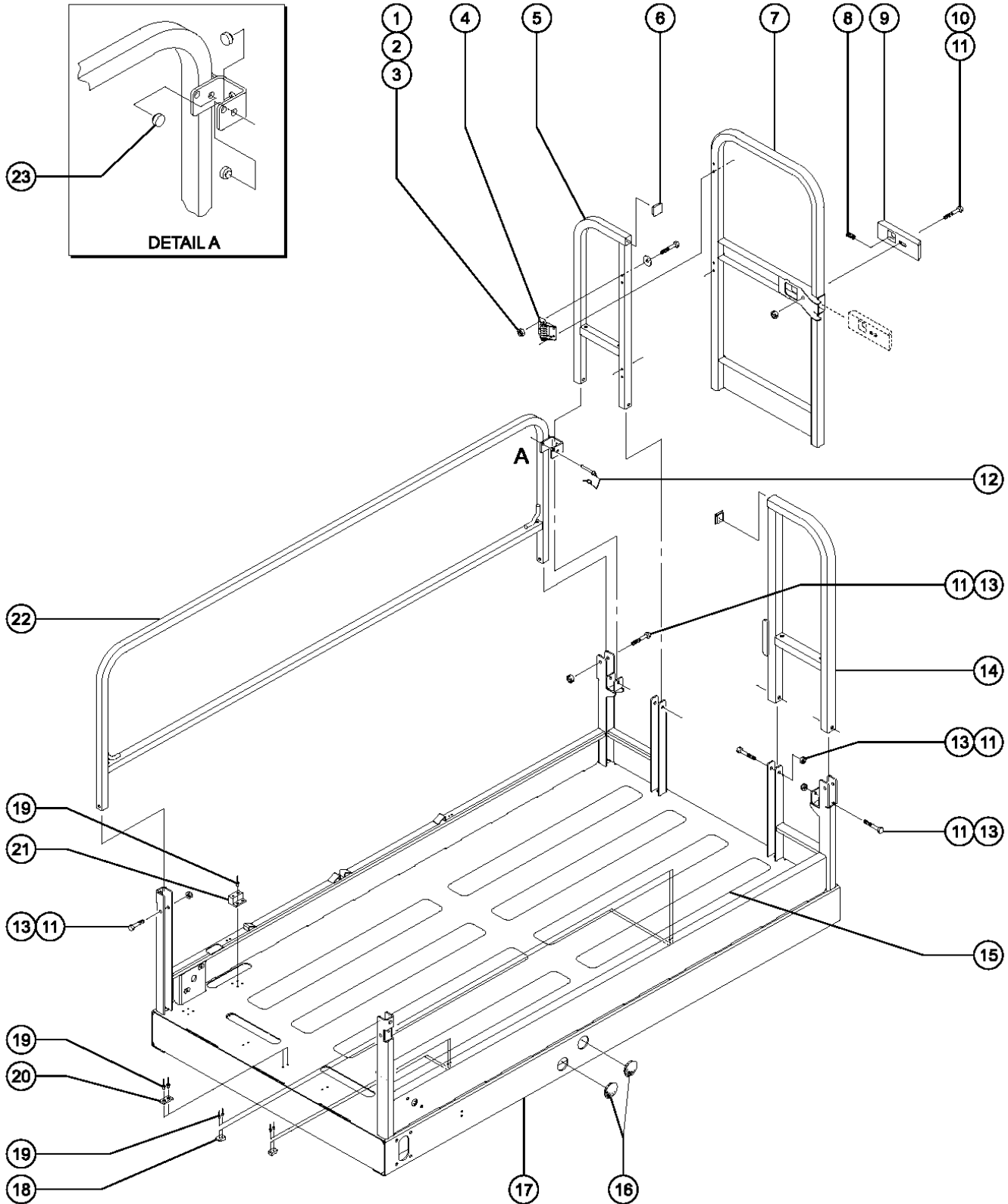

402.3 Platform Railings and Entry Gate - Fold Down Rails, Square Tube (from SN 23568)

Item	Part No.	Description	Qty.	Item	Part No.	Description	Qty.
A	97006GT	PLAT ASSY W/DECALS,S2046,ANS/C		--	97157GT	PLAT MAIN SQ ASSY GS3246 AUS.....1 <i>(includes items 15, 16, and 18-21)</i>	
--	97007GT	PLAT ASSY W/DECALS,S2046, CE		--	97159GT	PLAT MAIN SQ ASSY GS3246 CE.....1 <i>(includes items 15, 16, and 18-21)</i>	
--	97166GT	PLTFRM ASSY CMPLT, GS2046AUS		18	39317GT	STOP PLATFORM ROLLER.....4 <i>(4.14 x 2.5 cm)</i>	
B	97008GT	PLAT ASSY W/DECALS,S2646,ANS/C		19	39579GT	RIVET,STL,STL,.188 X .45.....26	
--	97009GT	PLAT ASSY W/DECALS,S2646, CE		20	39474GT	WEAR PAD,PLATFORM.....3 <i>(5.1 x 2.5 x 0.64 cm)</i>	
--	97161GT	PLTFRM ASSY GS2646 AUS, SQ		21	39310GT	WEAR/GUIDE PAD MAIN PLATFORM...4	
C	97010GT	PLAT ASSY W/DECALS,S3246,ANS/C		22	82052-SGT	RAIL-GS46 PLAT,MAINDECK RT****.....1 <i>(ground controls side) (shown)</i>	
--	97011GT	PLAT ASSY W/DECALS,S3246, CE		--	82053-SGT	RAIL-GS46 PLAT,MAINDECK LT****.....1 <i>(battery pack side)</i>	
--	97168GT	PLTFRM ASSY CMPLT, GS3246AUS		23	43392GT	BUMPER,BATTERY BOX & RAILS.....6	
1	6091GT	NUT,NYLOCK,1/4-20.....8					
2	6638GT	WASHER,FLAT,USS,1/4"Y.....8					
3	6637GT	SCREW,HHC,1/4-20 X 1.75.....8					
4	104804GT	HINGE, SPRING, LONG LEG.....2					
5	82054GT	RAIL-GS46 PLAT ENTRY, MAIN.....1 <i>(includes 1 each item 6)</i>					
6	78038GT	CAP, TUBE, SQ,1.25 X .083.....2					
7	82056GT	GATE-GS46 PLATFORM ENTRY.....1 <i>(includes Item 9)</i>					
8	22446GT	SPRING,COMPRESSION .835 X 2.....1					
9	65990-SGT	KIT,GATE LATCH.....1 <i>(includes items 8, 10 and 1 each item 11)</i>					
--	66544GT	LATCH HANDLE					
10	5224GT	SCREW,HHC,3/8-16 X 2.....1					
11	4828GT	NUT,NYLOCK,3/8-16.....9					
12	66030GT	PIN, WIRE LOCK 3/8 X 2 -1/2.....2					
13	8178GT	SCREW,HHC,3/8-16 X 2.5.....8					
14	82055GT	RAIL-GS46 PLAT ENTRY, MAIN.....1 <i>(battery pack side)</i>					
15	47374GT	TAPE,NON-SKID,DIE CUT,4"X 32".....8 <i>(10.2 x 81.3 cm)</i>					
16	45840GT	PLUG,NYLON 2.00 BLACK DOMED.....4 <i>(5.1 cm)</i>					
17	97139GT	PLAT MAIN ASSY SQ GS2046 ANSI.....1 <i>(includes items 15, 16, and 18-21)</i>					
--	97153GT	PLAT MAIN ASSY SQ GS2046 AUS.....1 <i>(includes items 15, 16, and 18-21)</i>					
--	97154GT	PLAT MAIN SQ ASSY GS2046 CE.....1 <i>(includes items 15, 16, and 18-21)</i>					
17A	97140GT	PLAT MAIN ASSY SQ GS2646 ANSI.....1 <i>(includes items 15, 16, and 18-21)</i>					
--	97141GT	PLAT MAIN ASSY SQ GS2646 AUS.....1 <i>(includes items 15, 16, and 18-21)</i>					
--	97155GT	PLAT MAIN SQ ASSY GS2646 CE.....1 <i>(includes items 15, 16, and 18-21)</i>					
17B	97142GT	PLAT MAIN ASSY SQ GS3246 ANSI.....1 <i>(includes items 15, 16, and 18-21)</i>					
--	97143GT	PLAT MAIN ASSY SQ GS3246 CSA.....1 <i>(includes items 15, 16, and 18-21)</i>					



403.1 Platform Extension - Rigid Rails

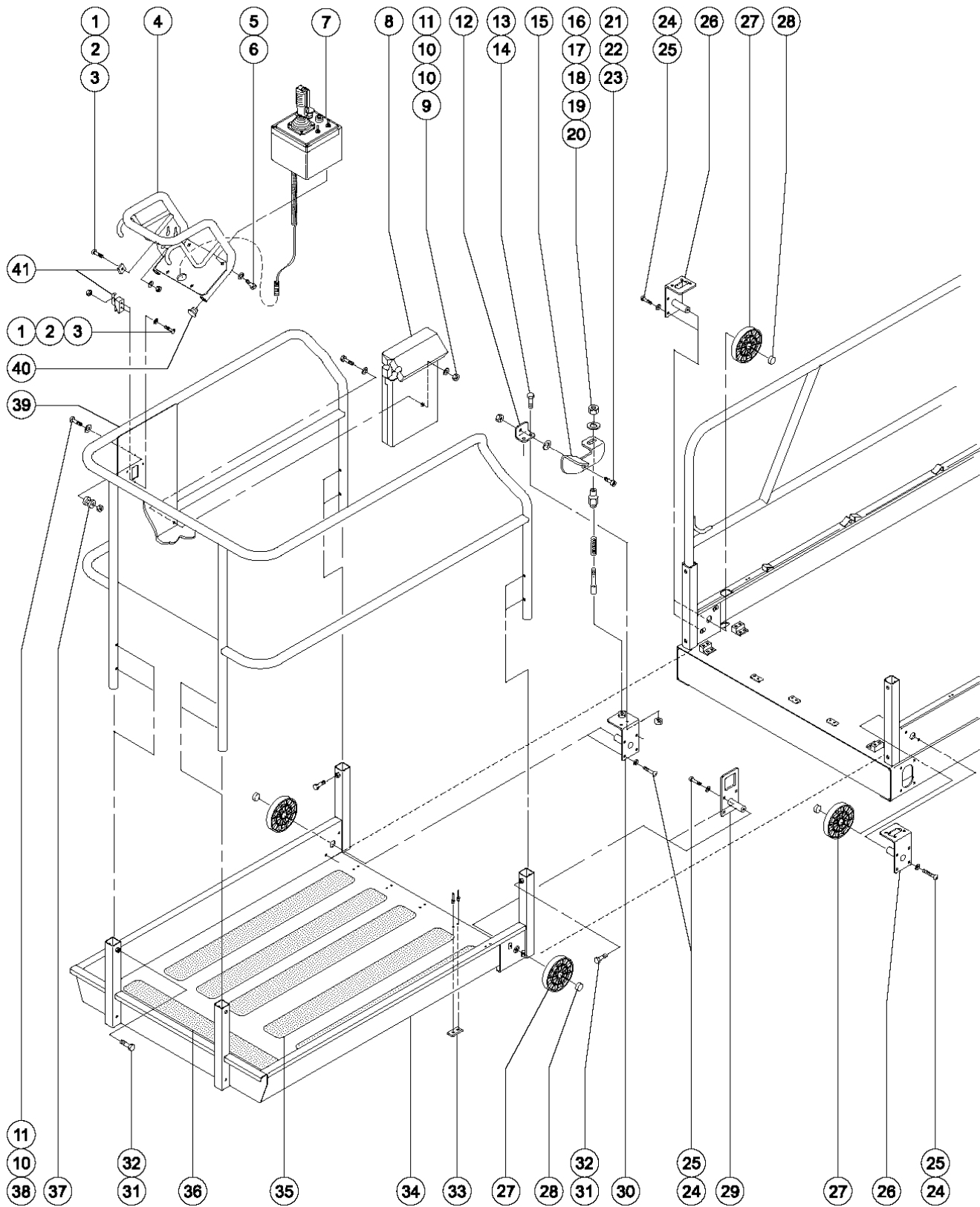

403.1 Platform Extension - Rigid Rails

Item	Part No.	Description	Qty.	Item	Part No.	Description	Qty.
1	47363GT	SCREW,RHM,8-32 X .50.....	3	33	39474GT	WEAR PAD,PLATFORM.....	5
2	35461GT	WASHER,FLAT,MS,#8,Y.....	3			(2 x 1 x 0.25 inch) (5.1 x 2.5 x 0.64 cm)	
3	18605GT	NUT,NYLOCK,8-32.....	3	34	97162GT	PLATFRM EXT ASSY GS46.....	1
4	39796GT	WELDMNT, ALUM,JOYSTICK GUARD.....	1			(includes items 32, 33, 35 and 36)	
5	47094GT	SCREW,HHC,5/16-18 X .50.....	4	35	47098GT	TAPE, NON-SKID, DIE CUT, 4" X 40".....	5
6	6886GT	WASHER, LOCK, .313.....	4			(10.2 x 101.6 cm)	
7		Ref. Platform Controls.....	1	36	47374GT	TAPE, NON-SKID, DIE CUT, 4" X 32".....	1
		(refer to Figure 406.1 or Figure 406.2)				(10.2 x 81.3 cm)	
8A	44743GT	MANUAL BOX W/DECALS***.....	1	37	66866GT	BUTTON,JOYSTICK MOUNT,BRASS***.....	3
		USA/Canada/Australia					
8B	24514GT	BOX,INSTRUCTION STORAGE Europe/Asia/South America (decals required; refer to Section100)	1	38	11968GT	SCREW,BHHS,1/4-20 X 1.....	3
9	6090GT	SCREW,HHC,1/4-20 X .75.....	4	39	48668GT	RAILING-PLAT EXT.W/DECALS,46".....	1
10	6638GT	WASHER,FLAT,USS,1/4"Y.....	11			(includes items 8, 9, and 4 each items 10 and 11)	
11	6091GT	NUT,NYLOCK,1/4-20.....	7	40	47389GT	PLUG,ROUND TUBING,1".....	2
12	47167PGT	BRACKET,FOOT PEDAL SUPPORT.....	1			(2.54 x 1.17 cm)	
13	8914GT	SCREW, HHC, 1/4-20 X .625.....	2	41	47218GT	DRAW LATCH,OVER-CENTER***.....	1
14	6889GT	NUT,LP NYLOCK,1/4-20.....	2				
15	46260GT	FOOTPEDAL W/NON-SKID TAPE,GS**.....	1				
--	47225GT	TAPE, NON-SKID, DIE CUT, 1.38X1.5.....	1				
		(3.51 x 3.8 cm)					
16	7713GT	NUT, LP NYLOCK, 3/8-16.....	1				
17	6097GT	WASHER,FLAT,USS,3/8",Y.....	1				
18	41630GT	HOUSING, LOCK PIN.....	1				
19	39469GT	SPRING,COMPRESSION.485 X1.75**...1	1				
20	39470GT	PIN, LOCK.....	1				
21	47227GT	SCREW,SHS,5/16-18 X .375.....	1				
22	47228GT	WASHER,NYLON,.406 X.750 X.032.....	1				
		(to SN 1797)					
22A	47222GT	WASHER,SHOULDER,NYLON.....	1				
		(from SN 1798)					
23	6002GT	NUT,LP NYLOCK,5/16-18.....	1				
24	39429GT	SCREW,BHHS,3/8-16 X 1.75.....	8				
25	6021GT	WASHER, LOCK, .375.....	8				
26	39448GT	WELDMNT,PLATFORM OUTLET.....	2				
27	47163GT	ROLLER,PLATFORM EXTENSION.....	4				
28	21279GT	BUTTON, .800 O.D. X .281.....	4				
		(20.3 mm)					
29	51290GT	PLATFORM LANYARD.....	1				
30	96413GT	WLDMT,LOCKING ROLLER SUPPORT.....	1				
		(ground controls side)					
31	39478GT	SCREW,HHC,3/8-16 X 2 FULL THRD....	4				
32	4828GT	NUT,NYLOCK,3/8-16.....	4				



403.2 Platform Extension - Fold Down Rails, Round Tube

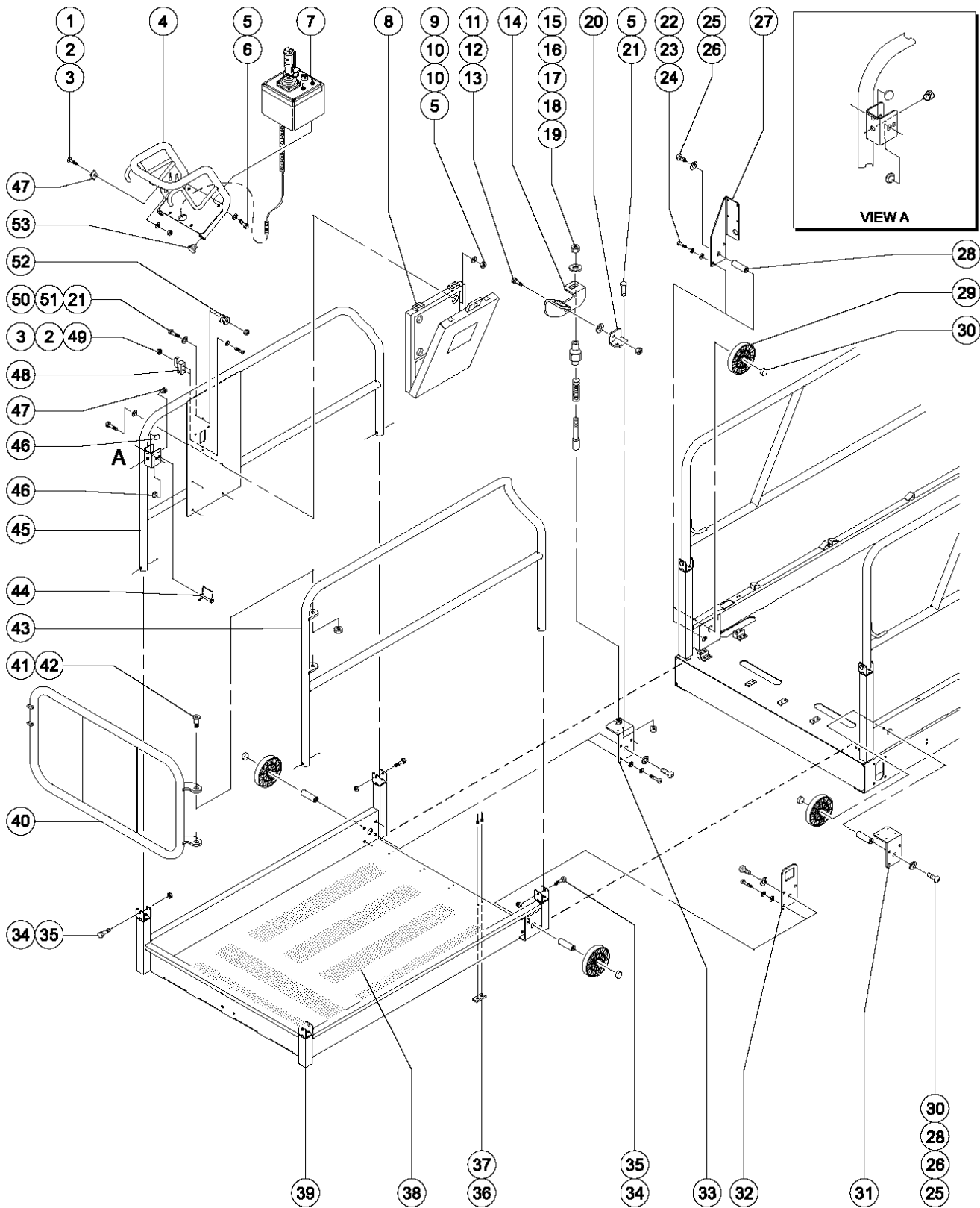



403.2 Platform Extension - Fold Down Rails, Round Tube

Item	Part No.	Description	Qty.	Item	Part No.	Description	Qty.
1	47363GT	SCREW,RHM,8-32 X .50.....	3	32	84586GT	LANYARD ROLLER BRKT ASSY W/DEC.....	1 <i>(includes one each item 30) (battery pack side)</i>
2	35461GT	WASHER,FLAT,MS,#8,Y.....	3	33	96413GT	WLDMT,LOCKING ROLLER SUPPORT.....	1 <i>(ground controls side)</i>
3	18605GT	NUT,NYLOCK,8-32.....	3	34	8178GT	SCREW,HHC,3/8-16 X 2.5.....	4
4	39796GT	WELDMNT, ALUM,JOYSTICK GUARD.....	1	35	4828GT	NUT,NYLOCK,3/8-16.....	4
5	6090GT	SCREW,HHC,1/4-20 X .75.....	4	36	39474GT	WEAR PAD,PLATFORM.....	5 <i>(5.1 x 2.5 x 0.64 cm)</i>
6	6886GT	WASHER,LOCK, .313.....	4	37	T113787GT	RIVET,ALUM,STL, .188 X .250.....	10
7		Ref. Platform Controls..... <i>(refer to Figure 406.2)</i>	4	38	47374GT	TAPE, NON-SKID, DIE CUT, 4" X 32".....	7 <i>(10.2 x 81.3 cm)</i>
8A	44743GT	MANUAL BOX W/DECALS***..... <i>USA/Canada/Australia</i>	1	39	97025GT	DECK ASSY-EXTENSION, GS46.....	1 <i>(includes items 36-38)</i>
8B	24514GT	BOX, INSTRUCTION STORAGE <i>Europe/Asia/South America (decal required; refer to Section100)</i>		40	97026GT	RAIL-EXT, FOLD DOWN END**.....	1
9	6091GT	NUT,NYLOCK,1/4-20.....	7	41	47255GT	BOLT,SHORT SHOULDER.....	2
10	6638GT	WASHER,FLAT,USS,1/4"Y.....	11	42	38028GT	NUT,LP NYLOCK,5/8-11.....	2
11	47227GT	SCREW,SHS,5/16-18 X .375.....	1	43A	55537GT	RAIL-PLATFORM EXT DECK, LS.....	1 <i>(battery pack side) for round rails</i>
12	47222GT	WASHER, SHOULDER, NYLON.....	1	43B	82058GT	RAIL-GS46 EXT DECK***.....	1 <i>for square rails</i>
13	6002GT	NUT,LP NYLOCK,5/16-18.....	1	44	66030GT	PIN, WIRE LOCK 3/8 X 2 -1/2.....	1
14	46260GT	FOOTPEDAL W/NON-SKID TAPE,GS**.....	1 <i>3.51 x 3.8 cm)</i>	45	62227GT	RAIL-EXT DECK,FOLDDOWN RS.....	1 <i>(ground controls side)</i>
--	47225GT	TAPE, NON-SKID, DIE CUT, 1.38X1.5.....	1 <i>3.51 x 3.8 cm)</i>	46	47478GT	BUMPER,RUBBER,1"OD X .461 H.....	2
15	7713GT	NUT, LP NYLOCK, 3/8-16.....	1	47	43392GT	BUMPER,BATTERY BOX & RAILS.....	1
16	6097GT	WASHER,FLAT,USS,3/8",Y.....	1	48	47218GT	DRAW LATCH,OVER-CENTER***.....	1
17	41630GT	HOUSING, LOCK PIN.....	1	49	78196GT	SCREW,PHP, 8-32 X 5/8.....	2
18	39469GT	SPRING,COMPRESSION.485 X1.75**.....	1	50	6888GT	SCREW,HHC,1/4-20 X 1.....	3
19	39470GT	PIN, LOCK.....	1	51	6638GT	WASHER,FLAT,USS,1/4"Y.....	3
20	47167PGT	BRACKET,FOOT PEDAL SUPPORT.....	1	52	66866GT	BUTTON,JOYSTICK MOUNT,BRASS***.....	3
21	6889GT	NUT,LP NYLOCK,1/4-20.....	2	53	47389GT	PLUG,ROUND TUBING,1".....	2 <i>(2.54 cm)</i>
22	39429GT	SCREW,BHHS,3/8-16 X 1.75.....	8				
23	6021GT	WASHER, LOCK, .375.....	8				
24	5397GT	WASHER,FLAT,USS,5/16",Y.....	8				
25	51692GT	SCREW,BHSC,5/8-11 X 1.....	4				
26	6036GT	WASHER,LOCK, .625 PLTD.....	4				
27	96247GT	WELDMNT,ROLLER BRACKET,RT***.....	1 <i>(ground controls side)</i>				
28	51367GT	PIN, THREADED ROLLER..... <i>(to SN 49620) (8.3 cm)</i>	4				
28A	96199GT	PIN, ROLLER..... <i>(from SN 49621)</i>	4				
29	47163GT	ROLLER,PLATFORM EXTENSION.....	4				
30	21279GT	BUTTON, .800 O.D. X .281..... <i>(20.3 mm)</i>	4				
31	96246GT	WELDMNT,ROLLER BRACKET,LT***.....	1 <i>(battery pack side)</i>				



403.3 Platform Extension - Fold Down Rails, Square Tube

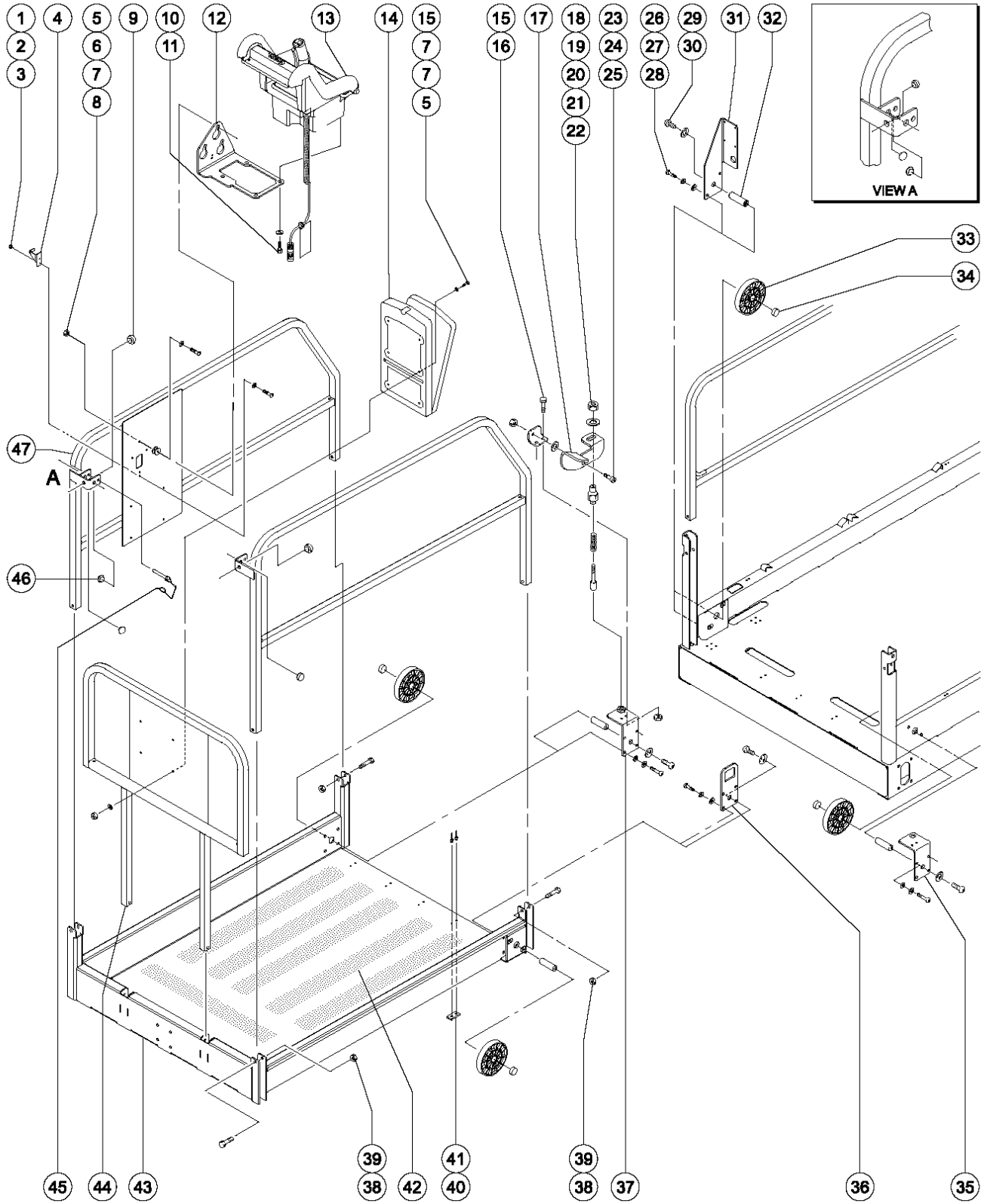

403.3 Platform Extension - Fold Down Rails, Square Tube

Item	Part No.	Description	Qty.	Item	Part No.	Description	Qty.
--	82100-SGT	GS46 PLAT W/EXT COMPLETE***		32A	96199GT	PIN, ROLLER (from SN 49621)	
1	18605GT	NUT,NYLOCK,8-32.....	2	33	47163GT	ROLLER,PLATFORM EXTENSION.....	4
2	35461GT	WASHER,FLAT,MS,#8,Y.....	2	34	21279GT	BUTTON, .800 O.D. X .281.....	4
3	55906GT	SCREW,PHILLIPS,PHM,8-32 X .5.....	2			(20.3 mm)	
4	65987GT	LATCH ASSEMBLY-CONTROL BOX.....	1	35	96246GT	WELDMENT,ROLLER BRACKET,LT***.....	1
		(includes item 5 and catch)				(battery pack side)	
5	6091GT	NUT,NYLOCK,1/4-20.....	7	36	84586GT	LANYARD ROLLER BRKT ASSY W/DEC.....	1
6	66866GT	BUTTON,JOYSTICK MOUNT,BRASS***.....	3			(battery pack side) (includes one each item 34)	
7	6638GT	WASHER,FLAT,USS,1/4"Y.....	11	37	96413GT	WLDMT,LOCKING ROLLER SUPPORT.....	1
8	11968GT	SCREW,BHHS,1/4-20 X 1.....	3			(ground controls side)	
9	43392GT	BUMPER,BATTERY BOX & RAILS.....	6	38	4828GT	NUT,NYLOCK,3/8-16.....	4
10	8255GT	SCREW, HHC, 3/8-16 X .75.....	4	39	8178GT	SCREW,HHC,3/8-16 X 2.5.....	4
11	6021GT	WASHER, LOCK, .375.....	4	40	39474GT	WEAR PAD,PLATFORM.....	5
12	66685GT	BRACKET,PLAT CONTROL BOX SLAB.....	1			(5.1 x 2.5 x 0.64 cm)	
13		Ref. Platform Controls.....	1	41	39579GT	RIVET,STL,STL,.188 X .45.....	10
		(refer to 406.1, 406.2, 406.3, or 406.4)		42	47374GT	TAPE,NON-SKID,DIE CUT,4"X 32".....	7
14A	44743GT	MANUAL BOX W/DECALS***.....	1			(10.2 x 81.3 cm)	
		USA/Canada/Australia		43	82051-SGT	GS46 EXT DECK-FOLD DOWN SQ.....	1
14B	24514GT	BOX,INSTRUCTION STORAGE Europe/Asia/South America (decals required; refer to Section100)				(includes items 40-42)	
15	6090GT	SCREW,HHC,1/4-20 X .75.....	4	44	82059-SGT	RAIL-GS46 EXT DECK.....	1
16	6889GT	NUT,LP NYLOCK,1/4-20.....	2	45	66030GT	PIN, WIRE LOCK 3/8 X 2 -1/2.....	2
17	46260GT	FOOTPEDAL W/NON-SKID TAPE,GS**.....	1	46	47478GT	BUMPER,RUBBER,1"OD X .461 H.....	3
--	47225GT	TAPE,NON-SKID,DIE CUT,1.38X1.5.....	1	47	82057GT	RAIL-GS46 EXT DECK***.....	1
		(3.51 x 3.8 cm)				(ground control side)	
18	7713GT	NUT, LP NYLOCK, 3/8-16.....	1	47A	82058GT	RAIL-GS46 EXT DECK***.....	1
19	6097GT	WASHER,FLAT,USS,3/8",Y.....	1			(battery pack side)	
20	41630GT	HOUSING, LOCK PIN.....	1				
21	39469GT	SPRING,COMPRESSION.485 X1.75**...1					
22	39470GT	PIN, LOCK.....	1				
23	47227GT	SCREW,SHS,5/16-18 X .375.....	1				
24	47222GT	WASHER,SHOULDER,NYLON.....	1				
25	6002GT	NUT,LP NYLOCK,5/16-18.....	1				
26	5224GT	SCREW,HHC,3/8-16 X 2.....	8				
27	6021GT	WASHER, LOCK, .375.....	8				
28	5397GT	WASHER,FLAT,USS,5/16",Y.....	8				
29	51692GT	SCREW,BHSC,5/8-11 X 1.....	4				
30	6036GT	WASHER,LOCK,.625 PLTD.....	4				
31	96247GT	WELDMENT,ROLLER BRACKET,RT***.....	1				
		(ground controls side)					
32	51367GT	PIN, THREADED ROLLER.....	4				
		(to SN 49620)					



404.1 Power to Platform - Rigid Rails

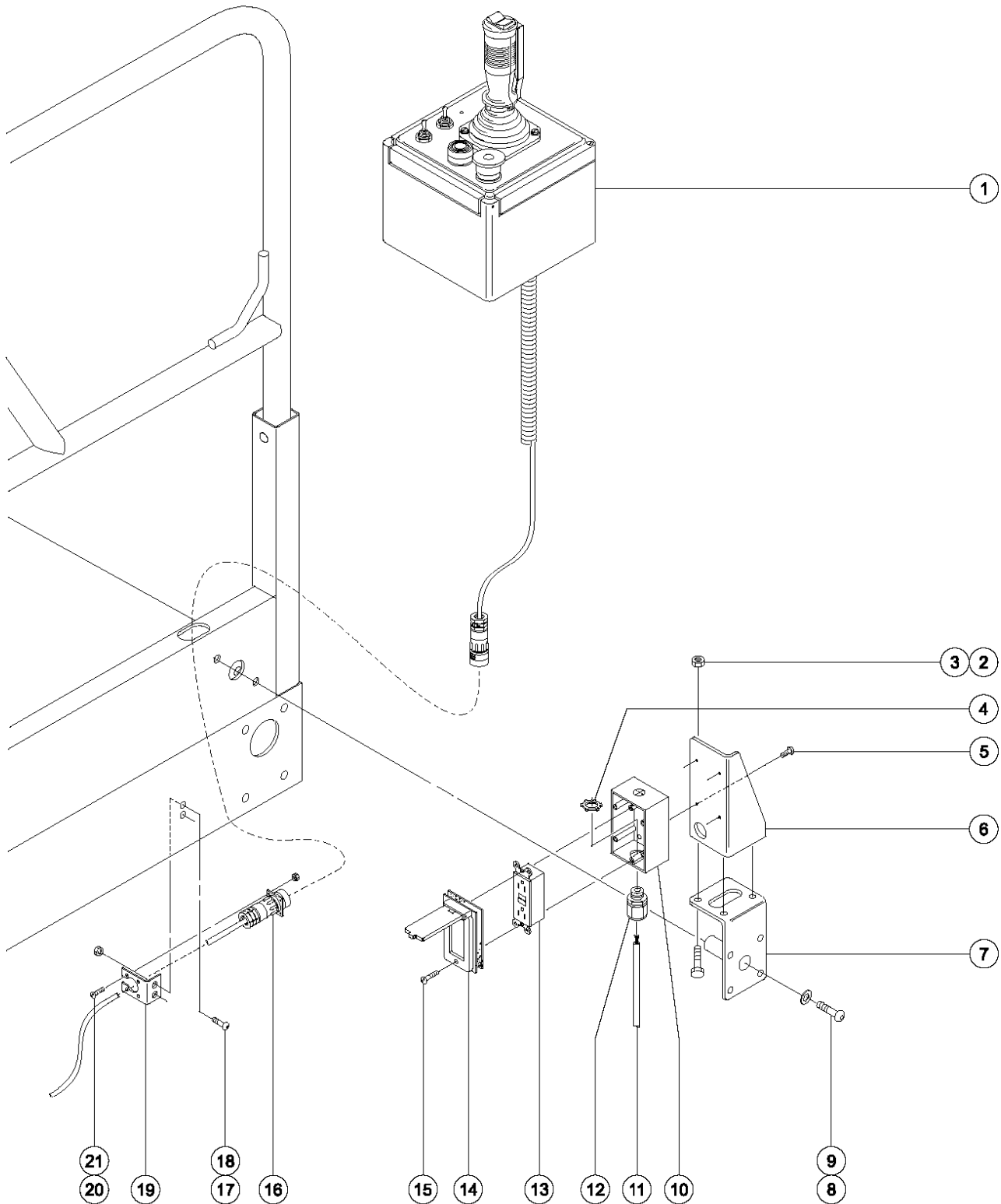

## 404.1 Power to Platform - Rigid Rails

Item	Part No.	Description	Qty.
1		Ref. Platform Controls.....1 (refer to Figure 406.1, 406.2, 406.3 or 406.4)	1
2	6889GT	NUT,LP NYLOCK,1/4-20.....3	3
3	8914GT	SCREW, HHC, 1/4-20 X .625.....3	3
4	6935GT	LOCKNUT,ELEC,1/2".....1	1
5	33759GT	SCREW,PHILLIPS,PHM,8-32 X.375.....4	4
6	97124GT	ROLLER BRKT ASSY W/DECAL.....1	1
7		Ref. Weldment - Roller Support, Platform Outlet.....1 (refer to 403.1 or 403.2 or 403.3)	1
8	39429GT	SCREW,BHHS,3/8-16 X 1.75.....2	2
9	6021GT	WASHER, LOCK, .375.....2	2
10	10775GT	T-BOX,2.75 X 4.5 X 2.0.....1	1
11	43956GT	WIRE CABLE,14/3 CON.TPE JKT*.....456-inches GS-2046 (11.6 m)	1
11A	43956GT	WIRE CABLE,14/3 CON.TPE JKT*.....516-inches GS-2646 (13.1 m)	1
11B	43956GT	WIRE CABLE,14/3 CON.TPE JKT*.....624-inches GS-3246 (15.8 m)	1
12	7056GT	CONN,SQUEEZE,1/2NPT .38-.50,SM....1 (12.7 mm)	1
13	13585GT	OUTLET,110V GFCI*** .....1 (North America)	1
14	45437GT	COVER,GFCI,WEATHERPROOF.....1 (North America) (includes mounting fasteners)	1
15	12348GT	SCREW,RHM,6-32 X .75.....2	2
16		Ref. Control Cable Assembly.....2 (refer to Figure 405.1)	2
17	12011GT	SCREW,BHHS,1/4-20 X .5,Y/ZINC.....1	1
18	6091GT	NUT,NYLOCK,1/4-20.....1	1
19	47867GT	BRACKET,JOYSTICK QUICK DISCNT...1	1
20	40767GT	SCREW,PHM,4-40 X .38 PHIL.....3	3
21	40766GT	NUT,NYLOCK,4-40.....3	3

404.2 Power to Platform - Fold Down Rails

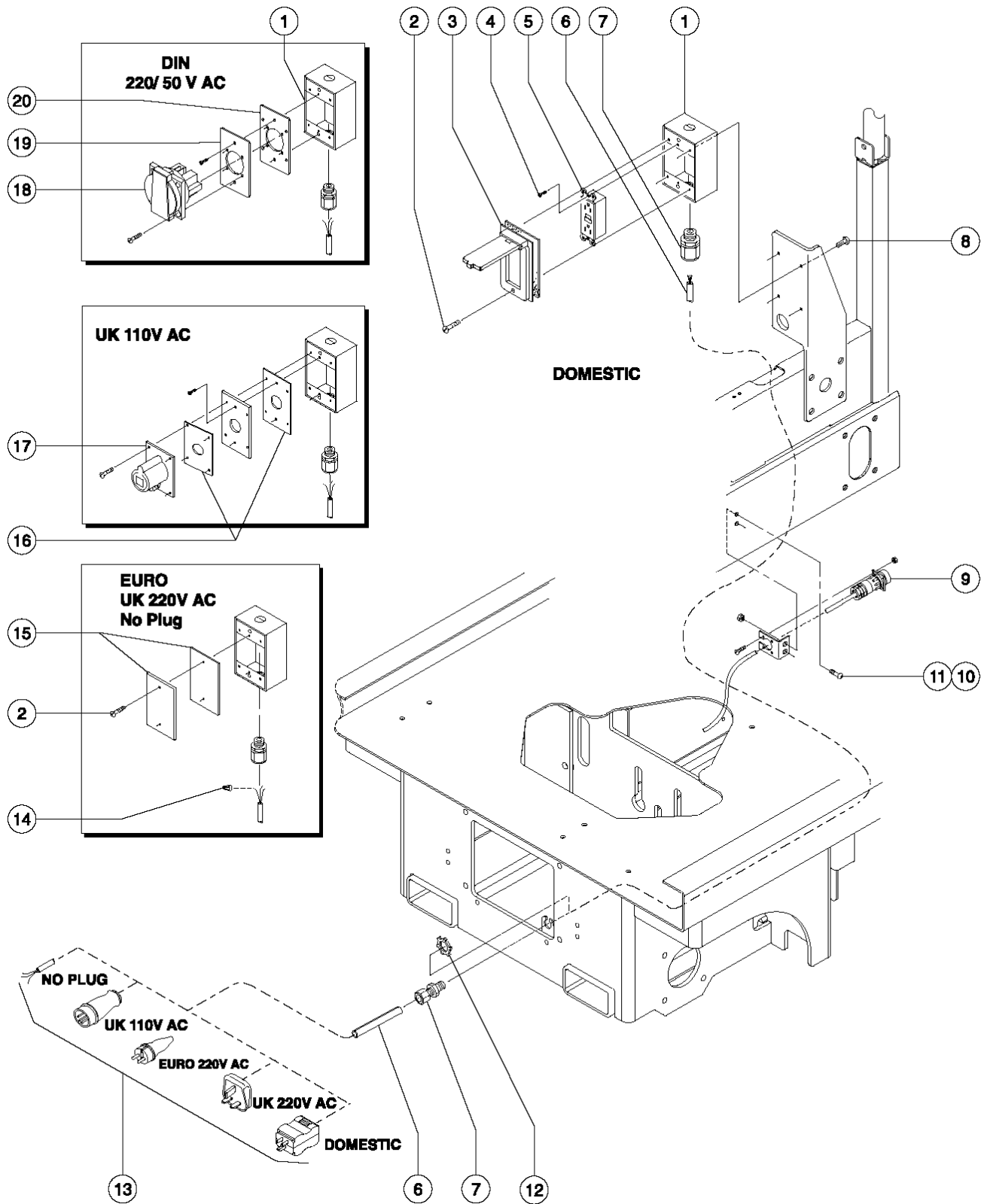

## 404.2 Power to Platform - Fold Down Rails

Item	Part No.	Description	Qty.
1	10775GT	T-BOX,2.75 X 4.5 X 2.0.....	1
2	7127GT	SCREW,PHILLIPS,PHM,6-32 X .75.....	2
3	45437GT	COVER,GFCI,WEATHERPROOF..... <i>(North America) (includes mounting fasteners)</i>	1
4	45546GT	SCREW,RHM,6-32 X .5.....	2
5	13585GT	OUTLET,110V GFCI***.....	1
6	43956GT	WIRE CABLE,14/3 CON.TPE JKT*.....456-inches <i>GS-2046 (11.6 m)</i>	
6A	43956GT	WIRE CABLE,14/3 CON.TPE JKT*.....516-inches <i>GS-2646 (13.1 m)</i>	
6B	43956GT	WIRE CABLE,14/3 CON.TPE JKT*.....624-inches <i>GS-3246 (15.8 m)</i>	
7	7056GT	CONN,SQUEEZE,1/2NPT .38-.50,SM.... <i>(12.7 mm)</i>	2
8	78196GT	SCREW,PHP, 8-32 X 5/8.....	4
9		Ref. Control Cable Assembly..... <i>(refer to Figure 405.1)</i>	4
10	14297GT	SCREW,BHHS,1/4-20 X .75.....	2
11	6091GT	NUT,NYLOCK,1/4-20.....	2
12	6935GT	LOCKNUT,ELEC,1/2".....	1
13	6595GT	PLUG,ELECTRICAL,DOMESTIC.....	1
--		Ref. No Plug - Consult Factory..... <i>(component no longer available) refer to BS1362 BUSS TDC180-13A</i>	1
--	144161GT	PLUG,PWR,UK,16AMP,3PIN,BLK.....	1
--	25388GT	PLUG,FUSED,250V,13AMP,U.K.**.....	1
--	6666GT	PLUG,ELECTRICAL,220/50,NOVON.....	1
14	6626GT	WIRE CAP,ORANGE.....	3
15	10777GT	COVER,BLANK.....	1
16	33724GT	KIT,GASKET,UK POWER TO PLAT..... <i>(includes one each p/n 66355 and 66356)</i>	1
--	66355GT	GASKET, UK & DIN PWR. TO PLAT. <i>4.6 x 2.9 inches</i>	
--	66356GT	GASKET, UK RECEPTACLE <i>2.9 x 2.9 inches</i>	
17	T112563GT	SVC KIT,UK RECEPT.REPLACEMENT.....	1
18	66353GT	RECEPTACLE, DIN, 220V 50A.....	1
19	96236GT	PLATE,AC ADAPTER,DIN/UK***.....	1
20	33724GT	KIT,GASKET,UK POWER TO PLAT..... <i>(includes one each p/n 66355 and 66356)</i>	1

405.1 Control Cable - Chassis to Platform

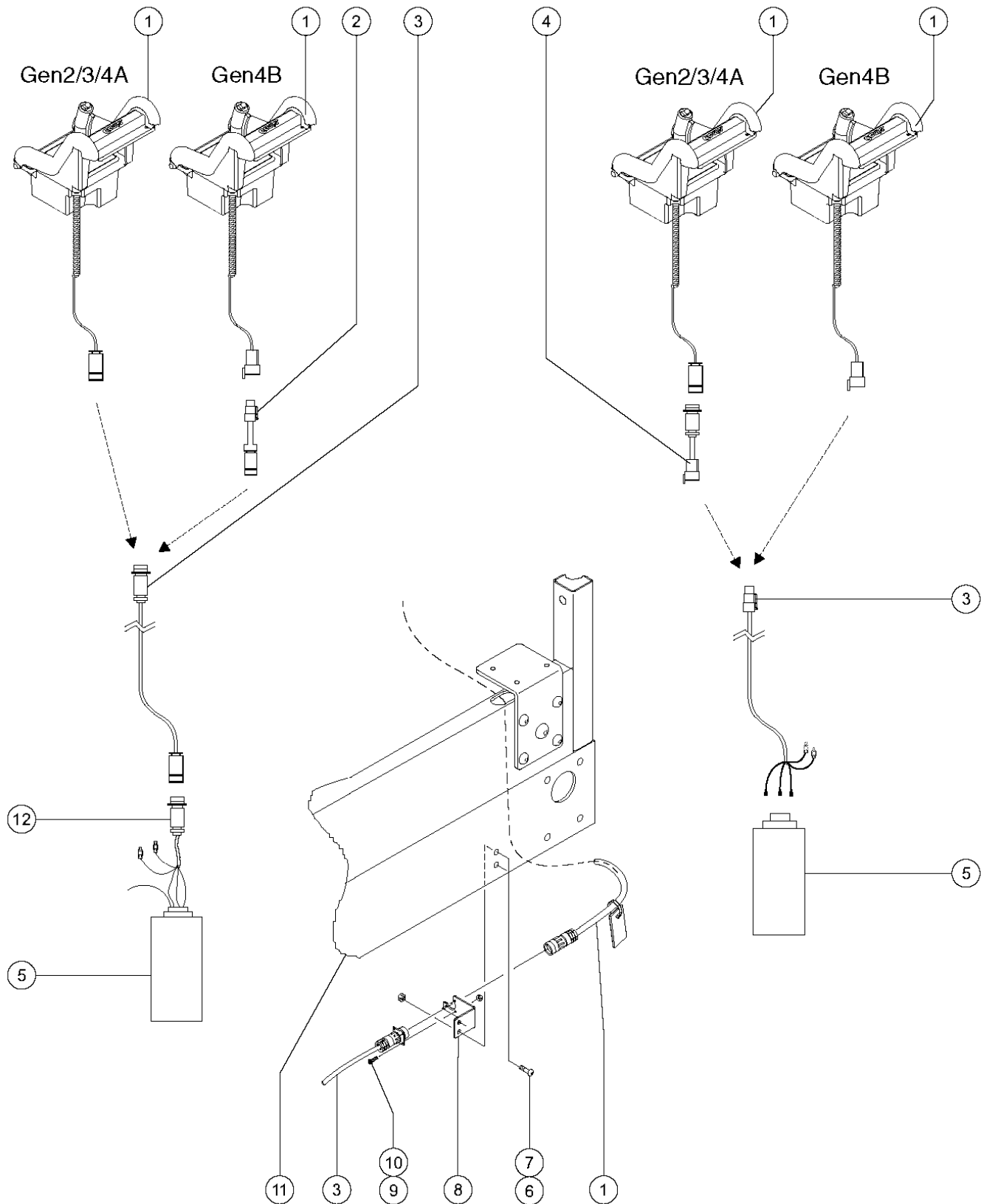



## 405.1 Control Cable - Chassis to Platform

Item	Part No.	Description	Qty.
1		Ref. Platform Control Box - Complete (refer to Figures 406.1, 406.2, 406.3 or 406.4)	
2	96019GT	ADAPTER, HARNESS (to SN 49199) (connects Gen 4 platform controls with Deutsch connector to machine harness with round connector)	
3	52157GT	CNTRL CABLE(FEM/FEM)GS-2046 **...1 (to SN 6843)	
--	51742GT	WIRE ASSY,GS2046.....1 (from SN 6844 to 49199)	
--	78314GT	CONNECTOR KIT,ITT CABLE/WIRE....1	
--	96014GT	WIRE ASSEMBLY,GS2046.....1 (from SN 49200)	
3A	52158GT	CNTRL CABLE(FEM/FEM) GS-2646**...1 (to SN 6843)	
--	51743GT	WIRE ASSY,GS2646.....1 (from SN 6844 to 49199)	
--	78314GT	CONNECTOR KIT,ITT CABLE/WIRE....1	
--	96015GT	WIRE ASSEMBLY,GS2646/2632.....1 (from SN 49200)	
3B	52158GT	CNTRL CABLE(FEM/FEM) GS-2646**...1 (to SN 6843)	
--	51744GT	WIRE ASSY,GS3246.....1 (from 6844 to 49199)	
--	78314GT	CONNECTOR KIT,ITT CABLE/WIRE....1 (from SN 6844 to 49199)	
--	96016GT	WIRE ASSEMBLY,GS3246.....1 (from SN 49200)	
4	96020GT	ADAPTER, HARNESS.....1 (from SN 49200)	
5		Ref. Electronic Control Module.....1 (refer to Figure 211.1 or 211.2)	
6	14297GT	SCREW,BHHS,1/4-20 X .75.....2 (to SN 49199)	
7	6091GT	NUT,NYLOCK,1/4-20.....2 (to SN 49199)	
8	47867GT	BRACKET,JOYSTICK QUICK DISCNT...1 (to SN 49199)	
9	65430GT	SCREW,PHS,6-32 X 0.25.....3 (to SN 49199)	
10	12344GT	NUT,NYLOCK,6-32.....3 (to SN 49199)	
11		Ref. Platform.....3 (refer to Figures 402.1, 402.2, 402.3, 403.1, 403.2 or 403.3)	
12	64258GT	WIRE ASSY,CHASSIS CONTROL PIGT.....1 (to SN 49199)	

406.1 Platform Controls (to SN 17407)

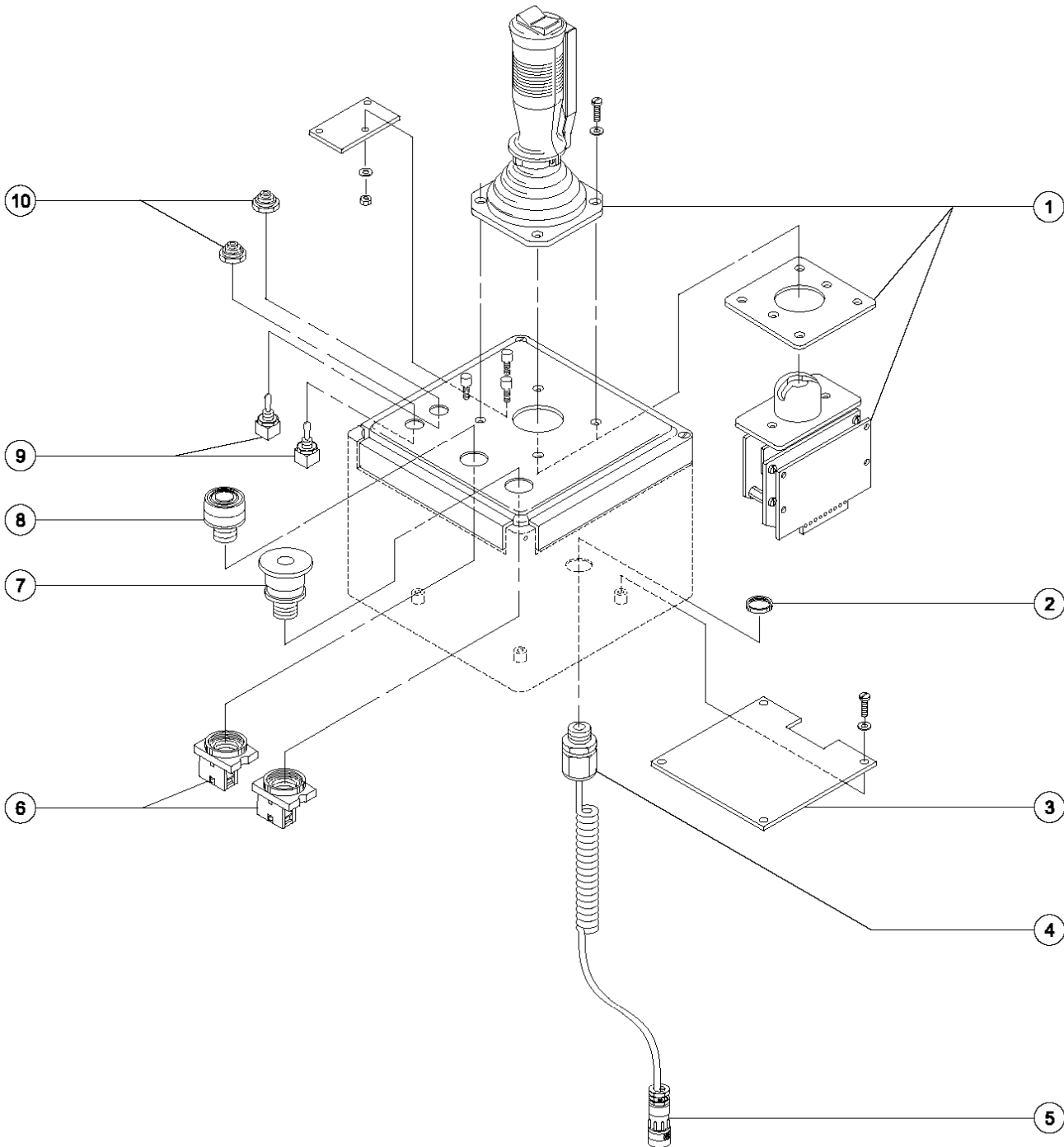

406.1 Platform Controls (to SN 17407)

Item	Part No.	Description	Qty.
--	105295GT	KIT,GEN1 TO GEN5 CONTRL SYS***	
--	46253GT	PCB,ASSY,LED,GS JOYSTICK	
--	58914GT	BOX, GRAY SCISSOR CONTROLLERS	
--	65297GT	PLATFRM CNTRLS W/DCLS 32/GS46	
--	83126GT	KIT,CONTROL BOX UPDATE,32/46	
1		Ref. Joystick Controller with Encoder Card <i>(refer to Figure 407.1)</i>	
2	46267GT	NUT-STRAIN RELIEF-GS JOYSTICK~...1	
3	105295GT	KIT,GEN1 TO GEN5 CONTRL SYS*** .....1	
4	46266GT	STRAIN RELIEF-GS JOYSTICK**~.....1	
5	46254GT	COIL CORD ASSY,GS JOYSTICK***.....1 <i>includes connector</i>	
6		Ref. Base.....2 <i>(refer to items 7 or 8)</i>	
7	66761GT	SERVICE KIT,E-STOP.....1 <i>(this is an update kit; the original E-stop button is no longer available from the supplier. Please note, if this kit has already been installed on the unit, refer to the part numbers listed below)</i>	
--	66812GT	BUTTON,PUSH,RED MUSHROOM HEAD	
--	66817GT	BASE WITH 1 NC CONTACT, E-STOP	
--	66818GT	CONTACT,NC	
8	66762GT	SERVICE KIT,E-DOWN 3246.....1 <i>(this is an update kit; the original black push button is no longer available from the supplier. Please note, if this kit has already been installed on the unit, refer to the part numbers listed below)</i>	
--	66813GT	BUTTON,PUSH,BLACK W/SEAL***	
--	66815GT	BASE, W/1 N.O. CONTACTS***	
--	66816GT	CONTACT,N.O.	
9	66410GT	TOGGLE SWITCH, PREWIRED*** .....2	
10	27246GT	BOOT,TOGGLE SWITCH,SHORT*.....2	

406.2 Platform Controls (from SN 17408 to 42999)

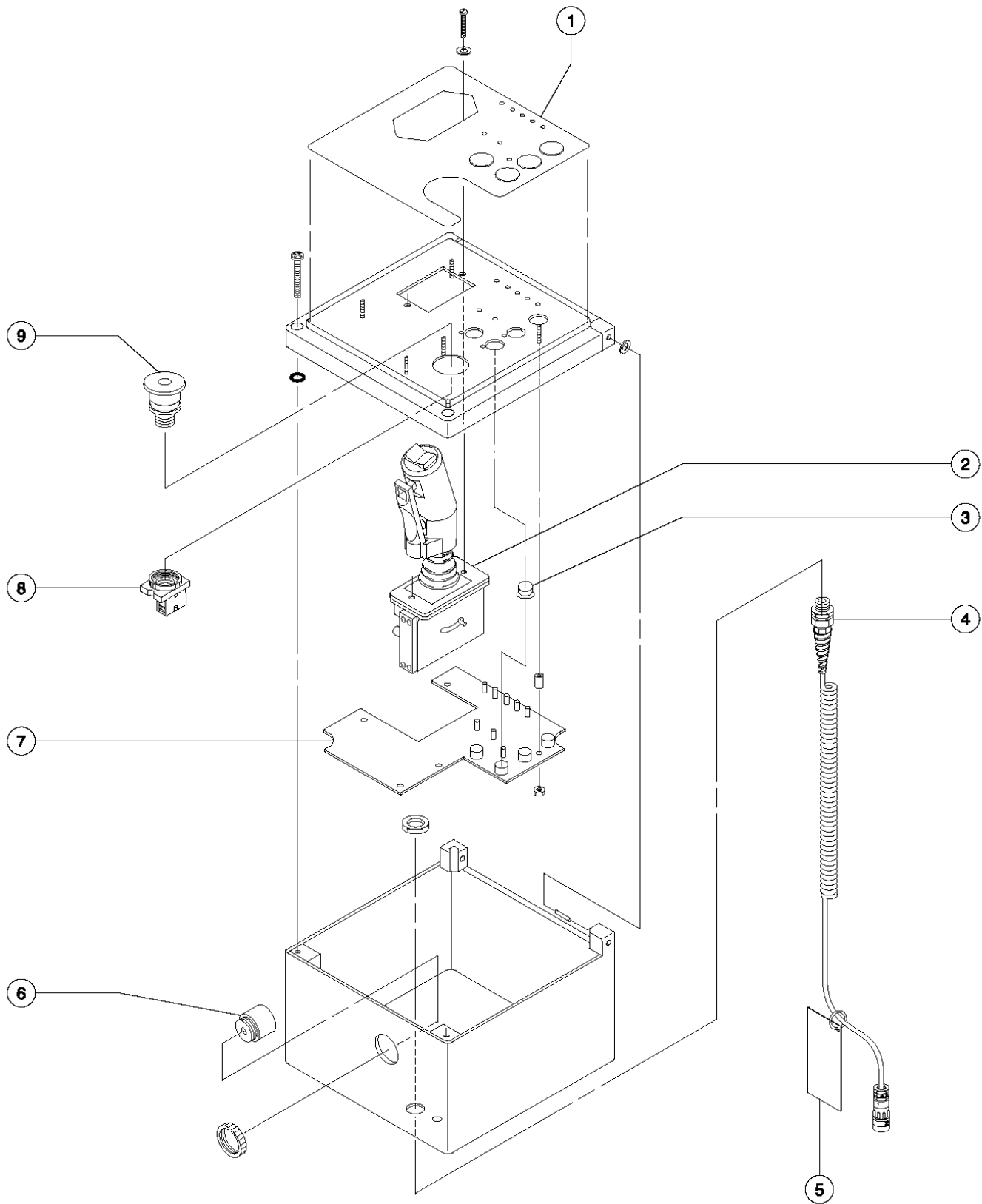

## 406.2 Platform Controls (from SN 17408 to 42999)

Item	Part No.	Description	Qty.
--	105295GT	KIT,GEN1 TO GEN5 CONTRL SYS*** (convert Gen 4 to Gen 5)	
--	65297GT	PLATFRM CNTRLS W/DCLS 32/GS46	
--	83126GT	KIT,CONTROL BOX UPDATE,32/46 (convert Gen 1-3 to Gen 4)	
1		Ref. Decal - Overlay, Platform Controls...1 (refer to Figure 101.1)	
2		Ref. Joystick Controller.....1 (refer to Figure 407.2)	
3	72254GT	ACTUATR,SWITCH,UNDER OVERLAY*~.....1	
4	62223GT	COIL CORD-JOYSTICK, SLABS.....1 (includes connector)	
5	66152GT	DOG TAG, CONTROL BOX.....1	
6	51860GT	ALARM ASSY.12VDC,ITT.....1 (Does not include 72326 nut)	
--	72326GT	NUT - PLASTIC,RING FOR ALARMS	
7	66158GT	PC BOARD,PLAT CNTRL,SLAB.....1	
8		Ref. Base, Push Button.....1 (refer to item 9) (to SN 36365)	
8A	66817GT	BASE WITH 1 NC CONTACT, E-STOP...1 (from SN 36366)	
--	66818GT	CONTACT,NC.....1 (from SN 36366)	
9	66761GT	SERVICE KITE,E-STOP.....1 (to SN 36365) (this is an update kit; the original E-stop button is no longer available from the supplier. Please note, if this kit has already been installed on the unit, refer to the part numbers listed below)	
9A	66812GT	BUTTON,PUSH,RED MUSHROOM HEAD.....1 (from SN 36366)	
--	66817GT	BASE WITH 1 NC CONTACT, E-STOP (from SN 36366)	
--	66818GT	CONTACT,NC (from SN 36366)	

406.3 Platform Controls (from SN 43000 to 48054)

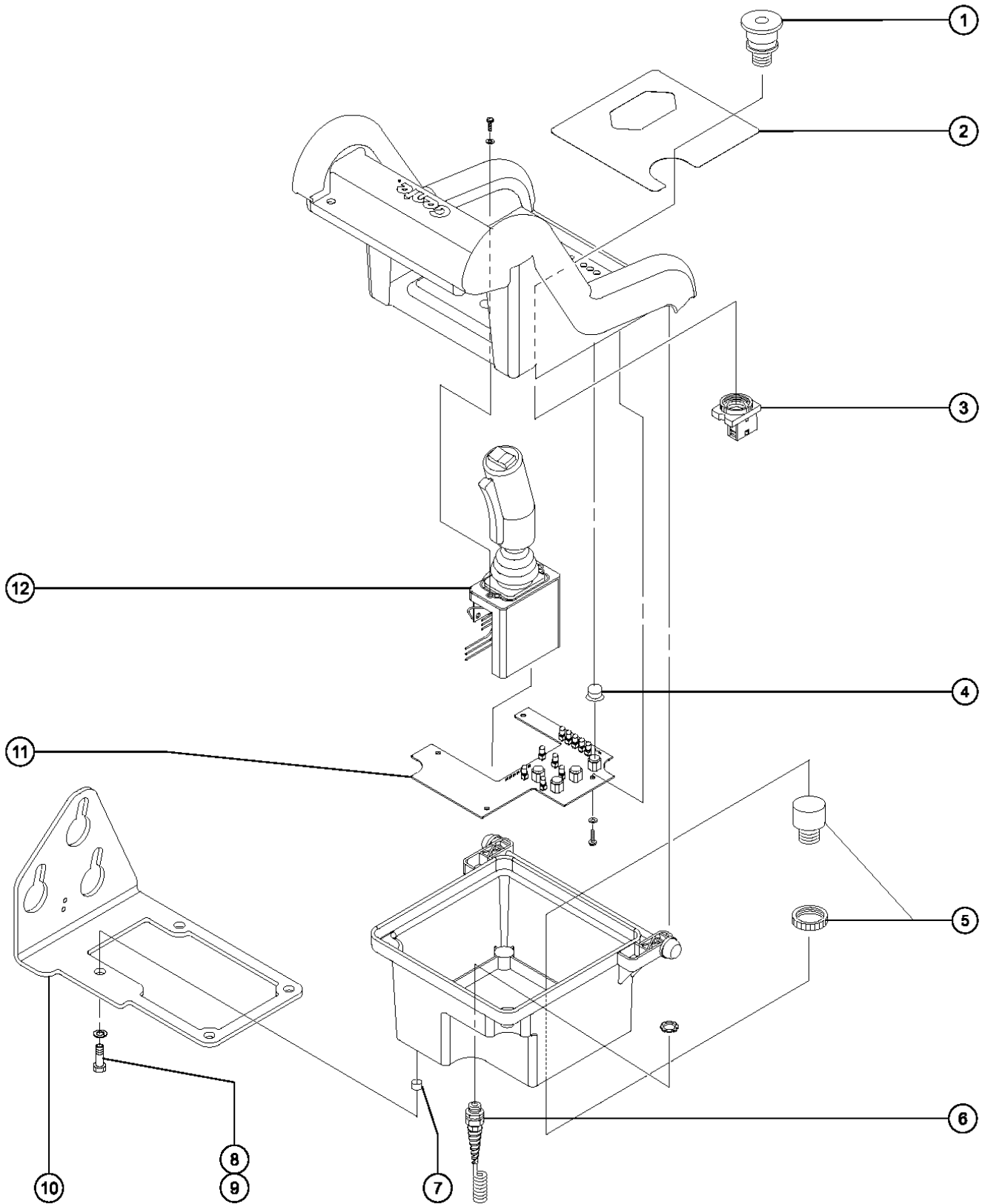

A TEREX BRAND

406.3 Platform Controls (from SN 43000 to 48054)

Item	Part No.	Description	Qty.
--	78805GT	BOX,MOLDED UPPER CONTROL	
--	96421GT	PLAT CONTRL,G4,DEC,IPCB,32/46 <i>(complete with decals)</i>	
1	66812GT	BUTTON,PUSH,RED MUSHROOM HEAD.....	1
2		Ref. Decal - Overlay, Platform Controls... <i>(refer to Figure 101.1)</i>	1
3	66817GT	BASE WITH 1 NC CONTACT, E-STOP...1	
--	66818GT	CONTACT,NC.....	1
4	72254GT	ACTUATR,SWITCH,UNDER OVERLAY*~.....	1
5	51860GT	ALARM ASSY.12VDC,ITT..... <i>(Does not include 72326 nut)</i>	1
--	72326GT	NUT - PLASTIC,RING FOR ALARMS.....	1
6	62223GT	COIL CORD-JOYSTICK, SLABS..... <i>(includes connector)</i>	1
7	66843GT	INSERT, 3/8-16 X .5.....	1
8	8255GT	SCREW, HHC, 3/8-16 X .75.....	4
9	6021GT	WASHER, LOCK, .375.....	4
10	66685GT	BRACKET,PLAT CONTROL BOX SLAB.....	1
11	66158GT	PC BOARD,PLAT CNTRL,SLAB.....	1
12		Ref. Controller - Joystick..... <i>(refer to figure 407.2)</i>	1

406.4 Platform Controls (from SN 48055)

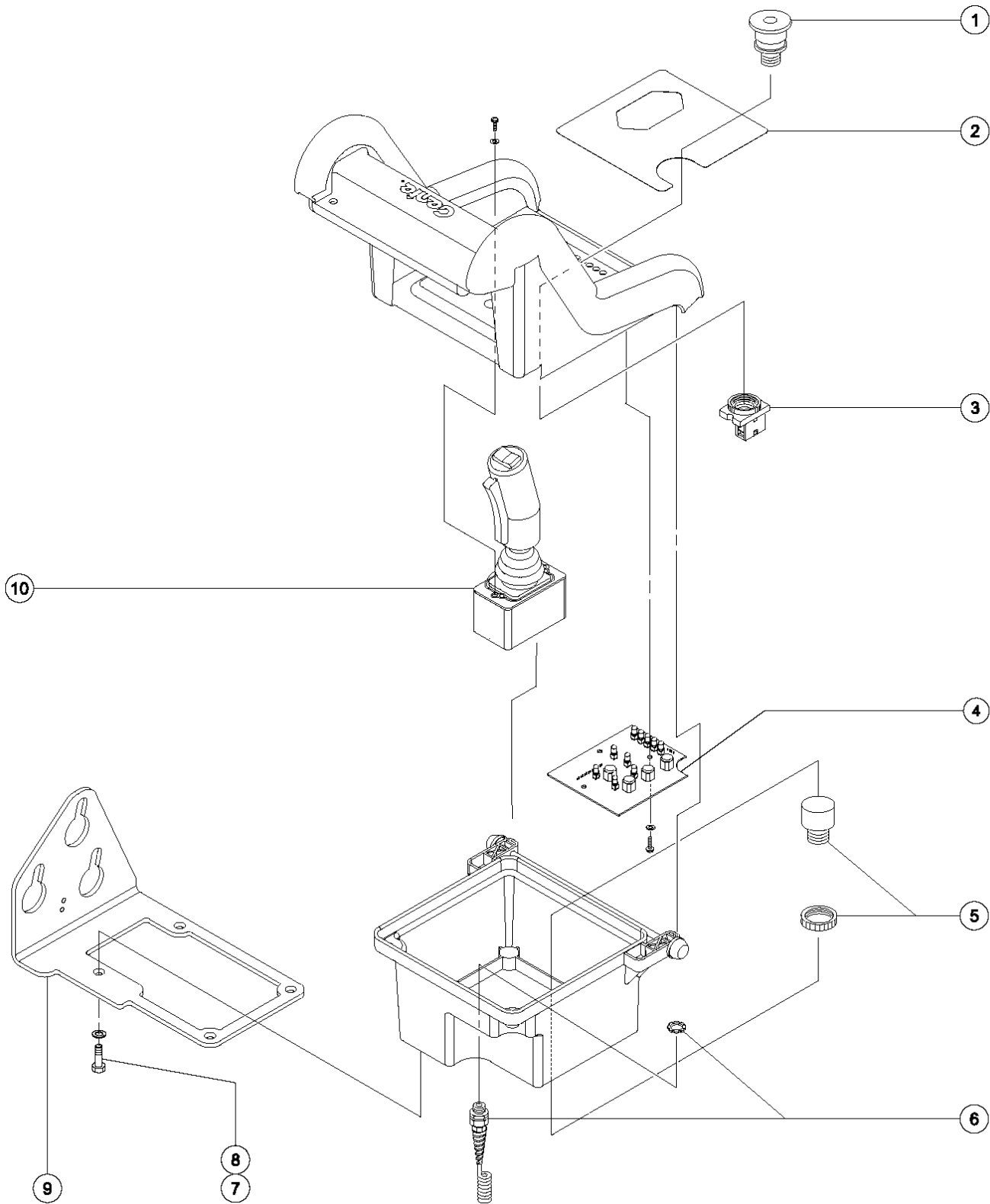



406.4 Platform Controls (from SN 48055)

Item	Part No.	Description	Qty.
--	78892GT	BOX,MOLDED UPPER CONTROL	
--	96020GT	ADAPTER, HARNESS <i>(connects Gen 4 platform controls with deutsch connector to machines from SN 17408 to 51015)</i>	
--	96421GT	PLAT CONTRL,G4,DEC,IPCB,32/46	
1	66812GT	BUTTON,PUSH,RED MUSHROOM HEAD.....	1
2	66157GT	OVERLAY,PLAT CONTROLLER SLAB....	1
3	66817GT	BASE WITH 1 NC CONTACT, E-STOP...	1
--	66818GT	CONTACT,NC.....	1
4	78904GT	PC BOARD,SLAB,GEN 4.....	1
5	51860GT	ALARM ASSY.12VDC,ITT..... <i>(Does not include 72326 nut)</i>	1
--	72326GT	NUT - PLASTIC,RING FOR ALARMS....	1
6	62223GT	COIL CORD-JOYSTICK, SLABS..... <i>(includes connector)</i>	1
7	8255GT	SCREW, HHC, 3/8-16 X .75.....	4
8	6021GT	WASHER, LOCK, .375.....	4
9	66685GT	BRACKET,PLAT CONTROL BOX SLAB.....	1
10		Ref. Controller - Joystick..... <i>(refer to Figure 407.3)</i>	1

407.1 Joystick Controller (to SN 17407)

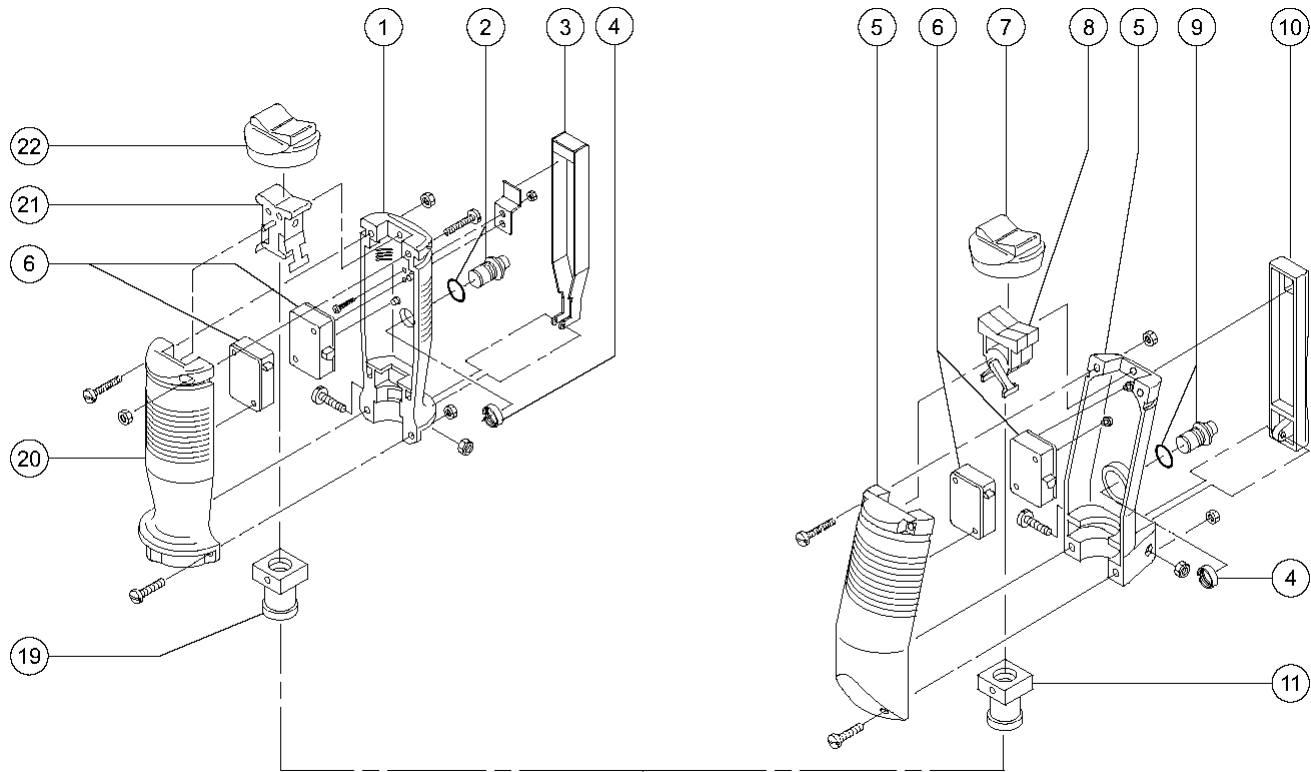

Control handle with metal function enable switch lever

Control handle with plastic function enable switch lever

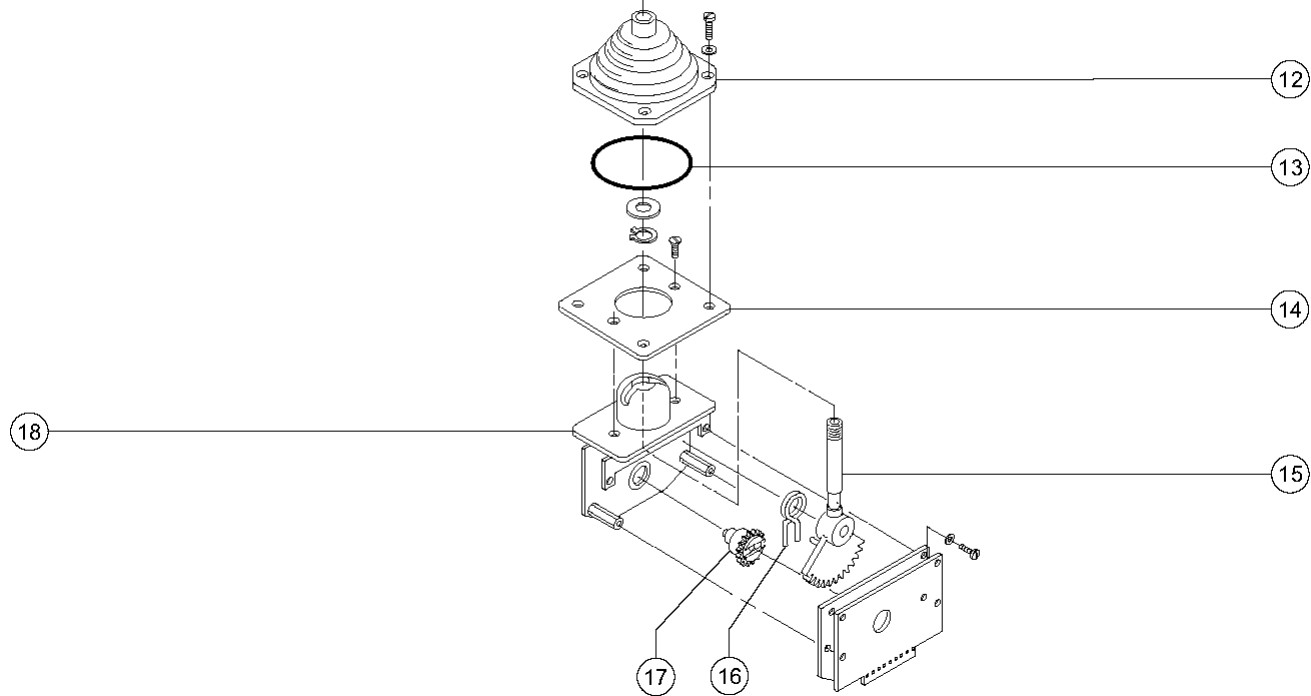

407.1 Joystick Controller (to SN 17407)

Item	Part No.	Description	Qty.	Item	Part No.	Description	Qty.
--		Genie GS-2646 models were produced using one of two different styles of control handles: one with a metal function enable switch lever, the other with a plastic function enable switch lever. A serial number break is not available. Refer to the specific machine to determine the style required. The GS-2046 and GS-3246 models were produced with the plastic function enable switch lever.		14		FLANGE-JOYSTICK MOUNTING.....1 <i>component no longer available</i>	1
--	44792GT	HANDLE HALF SET-FOR 44988 <i>(for models with metal function enable switch) (includes items 1-4 and 21)</i>		15	46227GT	SHAFT ASSY, JOYSTICK***.....1	1
--	44988GT	JOYSTICK W/ENCODER CARD-GS		--	69537GT	BEARING,JOYSTICK (57890).....1	1
--	65805GT	ENCODER W/PIGTAIL, 44988		16	21434GT	SPRING & BUSHING KIT,RETURN***...1	1
--	69537GT	BEARING,JOYSTICK (57890)		17	19731GT	GEAR, SLAVE, MS4,45048.....1	1
1	46274GT	HANDLE HALF,ENABLE SW.SIDE-GS...1 <i>(for models with metal function enable switch)</i>		18	19720GT	CASTING,45049, 40612.....1	1
2	46270GT	PUSHBUTTON-FUNC.ENABL.W/ORING.1 <i>(for models with metal function enable switch)</i>		19	43040GT	NUT,JS,36867/42032/44988/40612.....1 <i>(for models with metal function enable switch)</i>	1
3	46269GT	LEVER,FUNC.ENABL.SWITCH,METAL..1 <i>(for models with metal function enable switch)</i>		20	46275GT	HANDLE HALF-BACKSIDE,GS JYSTK...1 <i>(for models with metal function enable switch)</i>	1
4	46271GT	NUT-MOUNTING,PUSH BUTTON-44988.....1 <i>(for either model)</i>		21		ROCKER ASSEMBLY,45049.....1 <i>for models with metal function enable switch (Part No Longer Available)</i>	1
5	58293GT	HANDLE KIT,GS JYSTK,BOTH HALVE.....1		22	46268GT	BOOT-THUMB ROCKER, 44988 RED**.....1 <i>(for models with metal function enable switch)</i>	1
6	19722GT	MICROSWITCH-V319M***.....2 <i>(for either model)</i>					
7	43038GT	BOOT-THUMB ROCKER** BLACK.....1 <i>(for models with plastic function enable switch)</i>					
8	65178GT	ROCKER ASSY W/ROLLPIN***.....1 <i>(for models with plastic function enable switch)</i>					
9	52050GT	PUSHBUTTON-FUNC.ENABL.W/ORING.1 <i>(for models with plastic function enable switch)</i>					
10	52042GT	LEVER,FUNC ENABLE SWITCH,RGE**.....1 <i>(for models with plastic function enable switch)</i>					
11	52043GT	NUT,JOYSTICK,44988, RGE.....1 <i>(for models with plastic function enable switch)</i>					
12	27134GT	BOOT,CONTROLLER.....1 <i>includes 46272</i>					
--	46272GT	FLANGE-JOYSTICK MOUNTING,44988.....1					
13	31526GT	O-RING,BOOT,CONTROLLER.....1					



407.2 Joystick Controller (from SN 17408 to 48054)

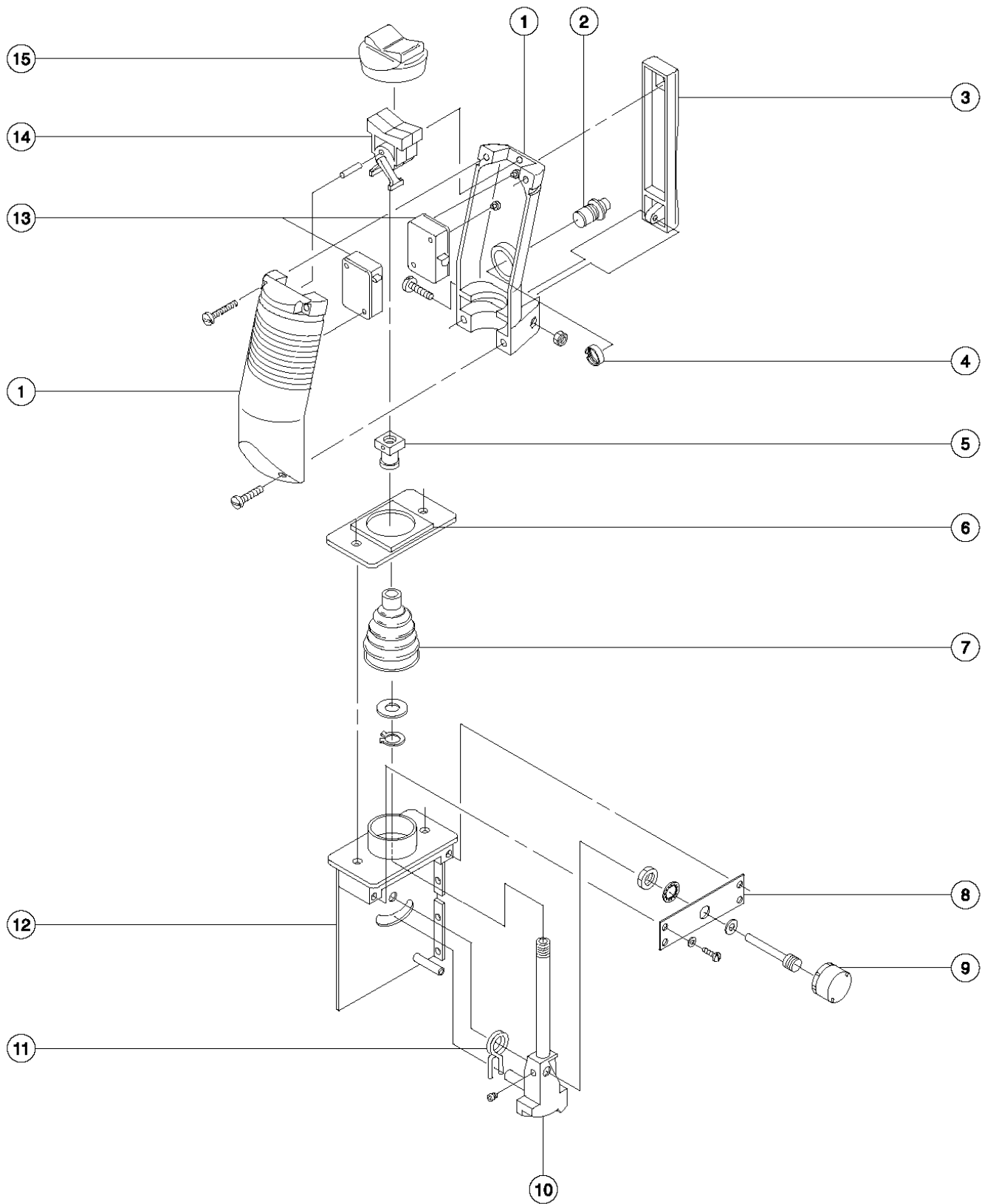

407.2 Joystick Controller (from SN 17408 to 48054)

Item	Part No.	Description	Qty.
--	62161GT	JOYSTICK CONTROLLER <i>(complete) (verify OEM P/N prior to ordering, label located on bottom of joystick)</i>	
--	62161HGT	JOYSTICK CONTROLLER <i>aftermarket joystick replacement</i>	
1	58293GT	HANDLE KIT,GS JYSTK,BOTH HALVE.....1 <i>Complete</i>	1
2	52050GT	PUSHBUTTON-FUNC.ENABL.W/ORING.1 <i>includes mounting hardware</i>	1
3	52042GT	LEVER,FUNC ENABLE SWITCH,RGE**.....1	1
4	46271GT	NUT-MOUNTING,PUSH BUTTON-44988.....1	1
5	52043GT	NUT,JOYSTICK,44988, RGE.....1	1
6	52529GT	GASKET-JOYSTICK.....1	1
7	21427GT	BOOT,CONTROLLER**.....1	1
8	52527GT	POTENTIOMETER MOUNT PLATE.....1	1
9	65179GT	POTENTIOMETER (62161)***.....1	1
10	52525GT	SHAFT ASSY,JOYSTICK.....1	1
11	21434GT	SPRING & BUSHING KIT,RETURN***.....1	1
12	65180GT	CASTING-JOYSTICK, GS2032.....1	1
13	19722GT	MICROSWITCH-V319M***.....2	2
14	65178GT	ROCKER ASSY W/ROLLPIN***.....1	1
15	19710GT	BOOT, PROTECTIVE, 45049 BLACK.....1	1

407.3 Joystick Controller (from SN 48055)

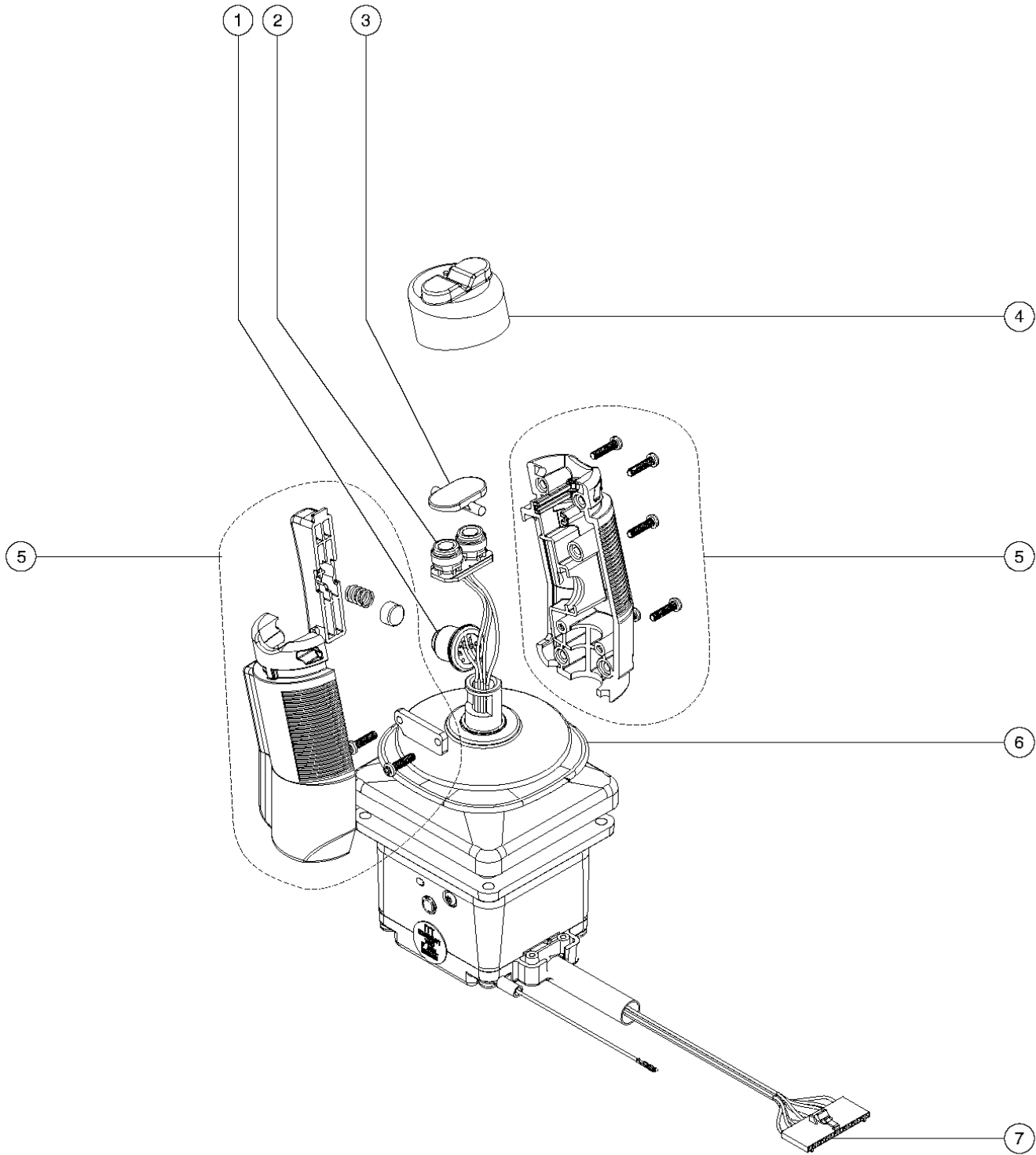

407.3 Joystick Controller (from SN 48055)

Item	Part No.	Description	Qty.
--	78903GT	JOYSTICK,SINGL AXIS,HALL,SLAB* <i>OEM joystick</i>	
--	78903HGT	JOYSTICK,SINGL AXIS,POT,SLAB <i>aftermarket joystick</i>	
1	105171GT	KIT,JOYSTICK ENABLE SWITCH.....1	
2	105115GT	KIT,JOYSTICK STEER SWITCH.....1	
3	150157GT	JOYSTIC HANDLE/SWITCH KIT.....1 <i>(for joysticks assembly 604038P)</i>	
3A	105109GT	TURN SWITCH ACTUATOR,JOYSTICK** .....1 <i>(for all joysticks except 604038P)</i>	
4	97015GT	BOOT,THUMB ROCKER*** .....1	
5	97014GT	JOYSTICK HANDLE SET, COMPLETE .....1 <i>(for all joysticks except 604038P)</i>	
6	97013GT	BOOT, JOYSTICK~ .....1	
7	105172GT	KIT, PLATFORM PC RECEIPT/SOC.....1	

501.1 Alarms - Horn and Flashing Beacon

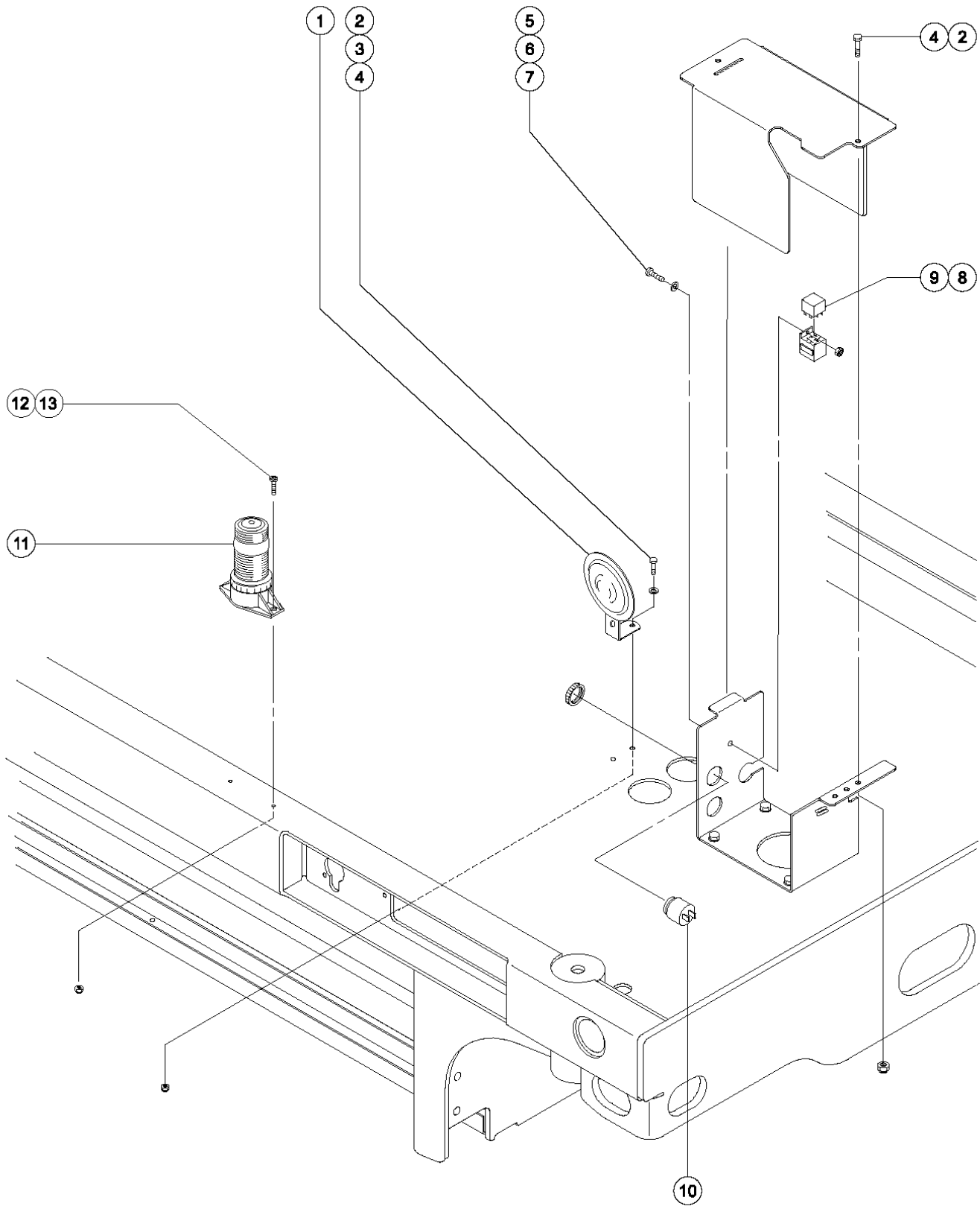



501.1 Alarms - Horn and Flashing Beacon

Item	Part No.	Description	Qty.
A	47676GT	GS SLAB AC BEACON <i>(includes wiring harness and installation instructions)</i>	
--	47663GT	HARNESS,BEACON ACCESSORY, SLAB	
--	48371GT	INSTALLATION INSTRC.BEACON	
B	47892GT	GS SLAB AC MOTION ALARM <i>(includes wiring harness and installation instructions)</i>	
--	47662GT	HARNESS,ALARM ACCESSORY	
--	47679GT	INSTALLATION INSTRUCT.,ALARM	
C	40826GT	GS SLAB AC HORN <i>(includes wiring harness and installation instructions)</i>	
--	105992GT	HORN HARNESS	
--	47680GT	INSTALLATION INSTRC.HORN	
1	81579GT	HORN,24VDC,SPADE TERMINALS***.....1	
2	8914GT	SCREW, HHC, 1/4-20 X .625.....3	
3	6638GT	WASHER,FLAT,USS,1/4"Y.....1	
4	6091GT	NUT,NYLOCK,1/4-20.....3	
5	47363GT	SCREW,RHM,8-32 X .50.....1	
6	35461GT	WASHER,FLAT,MS,#8,Y.....1	
7	18605GT	NUT,NYLOCK,8-32.....1	
8	56302GT	RELAY,24VDC,40/30A,SEALED***.....1	
9	34053GT	ASSY,RELAY SOCKET, AUTO.....1	
10	18963GT	ALARM,INTERMITTENT TONE 6-30V*...1 <i>(Does not include 72326 nut) (104 dB)</i>	
--	72326GT	NUT - PLASTIC,RING FOR ALARMS....1	
11	66909GT	STROBE,BEACON,W/OUT HARDWARE**.....2 <i>(12-48V DC, amber)</i>	
--	58973GT	LIGHT,REPLACEMENT BULB (39676)...2	
12	6606GT	SCREW,RHM,10-32 X .75.....4	
13	6178GT	NUT,NYLOCK,10-32.....4	

502.1 Air Line to Platform

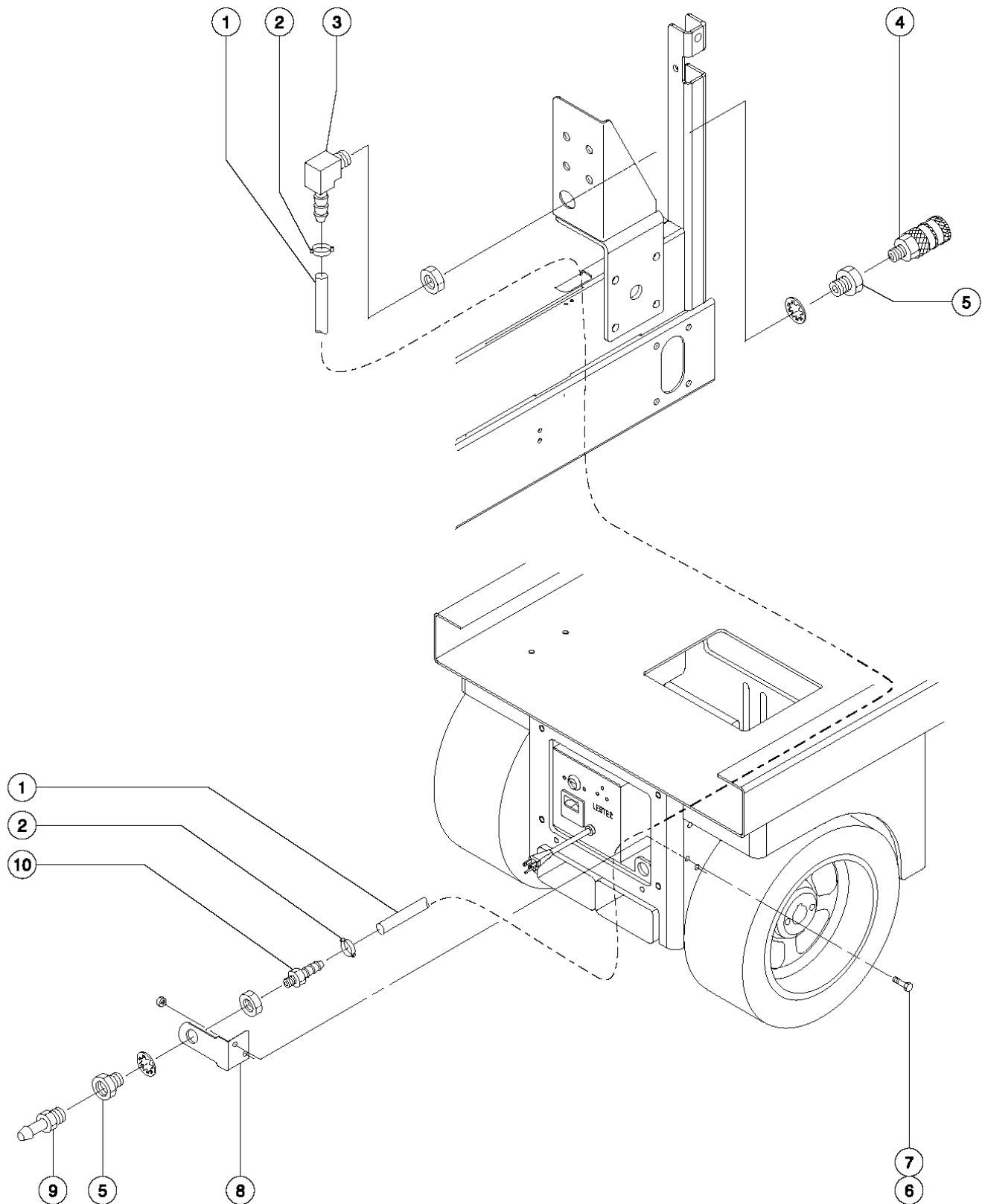

502.1 Air Line to Platform

Item	Part No.	Description	Qty.
--	47685GT	GS SLAB AC 2046 AIR TO PLAT <i>(complete)</i>	
--	47686GT	GS SLAB AC 2646 AIR TO PLAT <i>(complete)</i>	
--	47687GT	GS SLAB AC 3246 AIR TO PLAT <i>(complete)</i>	
1	27903GT	HOSE,LOW PRESSURE, .375 ID,BLK.....390-inches GS-2046	
1A	27903GT	HOSE,LOW PRESSURE, .375 ID,BLK.....490-inches GS-2646	
1B	27903GT	HOSE,LOW PRESSURE, .375 ID,BLK.....590-inches GS-3246	
2	27902GT	CLAMP,HOSE,2 EAR, 5/8.....2	
3	27904GT	HOSE END,BARBED,RIGID,90DEG6-6.....1	
4	27895GT	COUPLER,1/4"SERIES 3/8 MPT.....1	
5	27900GT	BULKHEAD,FEMALE X 6 X 6.....2 <i>(includes mounting fasteners)</i>	
6	6019GT	SCREW,HHC,3/8-16 X 1.25 GRD 5.....2	
7	48 28GT	Nut - Nylock, 3/8 -16.....2	
8	51595GT	PLATE,AIRLINE TO PLAT, GS46.....1	
9	27894GT	PLUG,1/4"SERIES,3/8 MPT.....1	
10	27901GT	HOSE END,BARBED,RIGID,-6-6.....1	

503.1 Platform Worklight

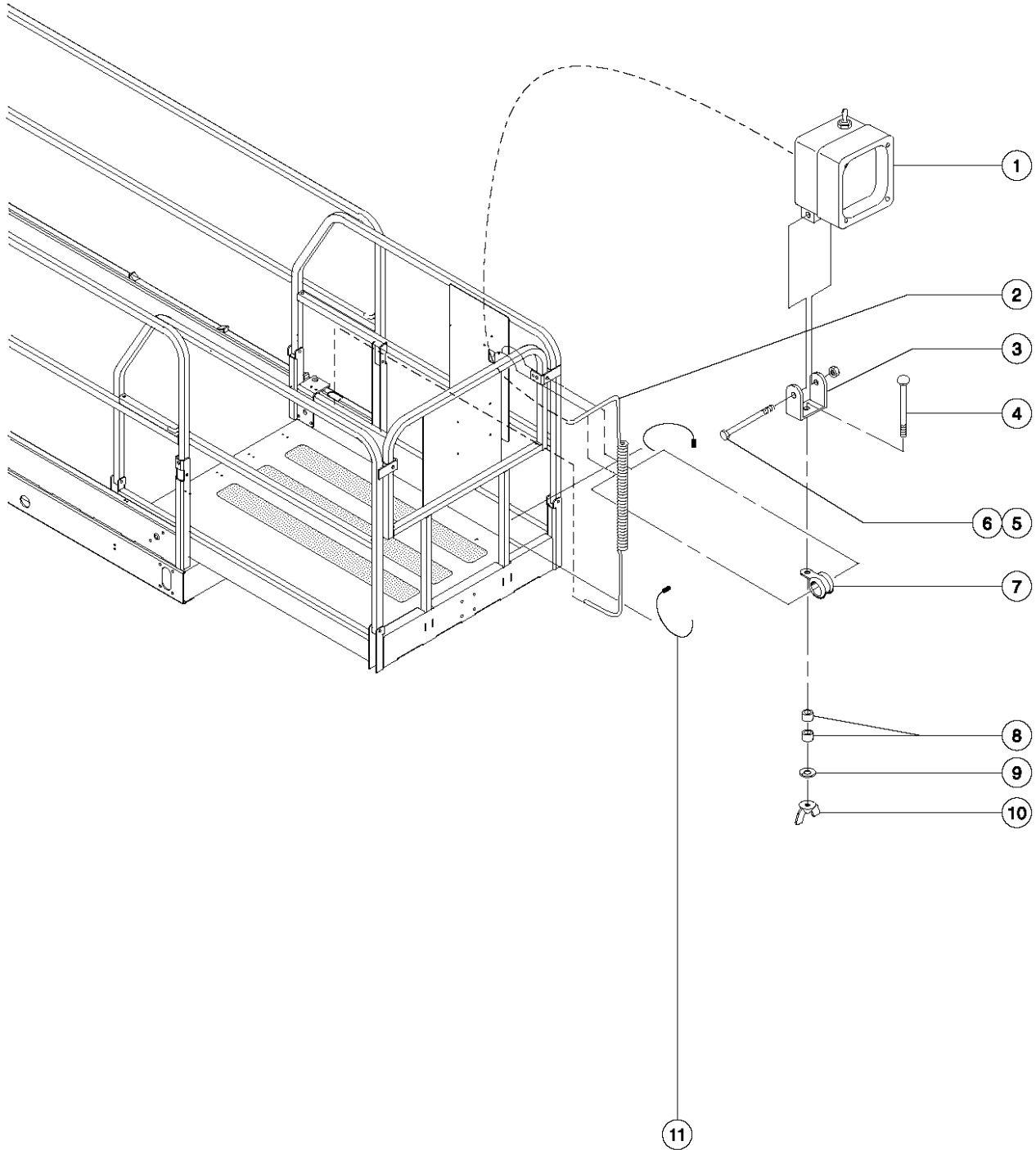

## 503.1 Platform Worklight

Item	Part No.	Description	Qty.
A	105920GT	WORKLIGHT ACCES,GS2032/2046 (complete)	
--	105971GT	WORKLIGHT PIGTAIL ASSY (chassis)	
--	105973GT	WORKLIGHT CABLE,GS19/20XX (linkset) GS-2046	
B	105921GT	WORKLIGHT ACCES,GS2632/2646 (complete)	
--	105971GT	WORKLIGHT PIGTAIL ASSY (chassis)	
--	105974GT	WORKLIGHT CABLE,GS26XX (linkset) GS-2632, GS-2646	
C	105921GT	WORKLIGHT ACCES,GS2632/2646 (complete)	
--	105971GT	WORKLIGHT PIGTAIL ASSY (chassis)	
--	105975GT	WORKLIGHT CABLE,GS32XX (linkset) GS-3232, GS-3246	
1	144011GT	WORKLIGHT,24V,COIL CORD.....	1
2	65721GT	COIL CORD,WORKLIGHT(144011).....	1
3	144011GT	WORKLIGHT,24V,COIL CORD.....	1
4	65439GT	BOLT,CARRIAGE,5/16-18 X 2.0,G2.....	1
5	50793GT	SCREW,HHC,5/16-18 X 2.....	1
6	6782GT	NUT,NYLOCK,5/16-18.....	1
7	33784GT	CLAMP,1.31,#21 X 1/4,RUB CUSH..... (3.3 cm)	1
8	65435GT	SPACER, .35ID X .785OD X .435..... (0.89 x 0.2 x 1.1 cm)	2
9	6886GT	WASHER,LOCK,.313.....	1
10	69229GT	NUT,WING 5/16-18.....	1
11	28443GT	CABLE TIE,11.5" BLACK..... (29.2 cm)	2

504.1 Platform Overload Protection

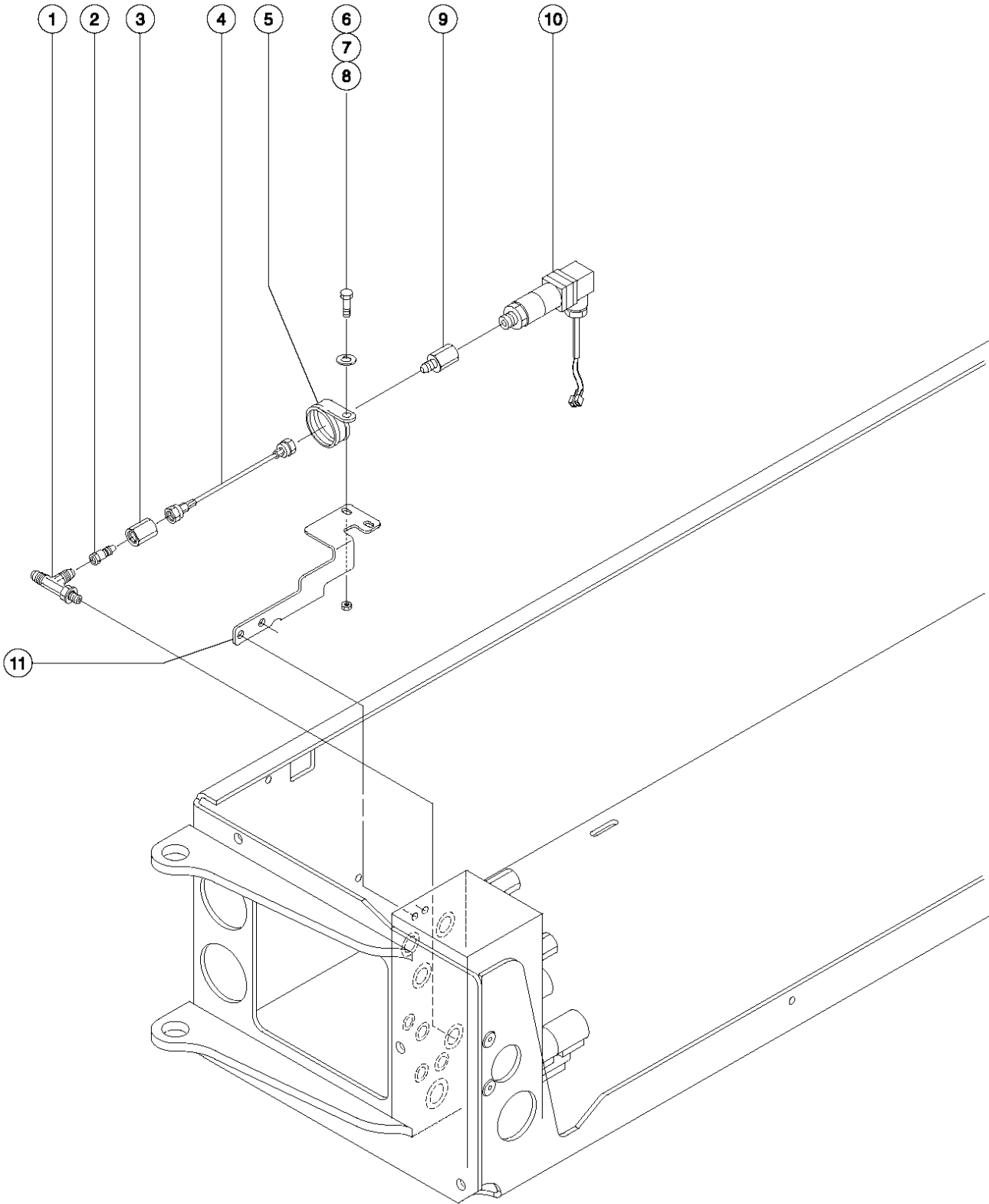

504.1 Platform Overload Protection

Item	Part No.	Description	Qty.
--	51328GT	GS SLAB AC LOAD SENSOR <i>(Complete) (from SN 17408)</i>	
--	66446GT	GS SLAB AC LD SENSOR (RLY) <i>(Complete) (to SN 17407)</i>	
1	51152GT	TEE,RUN 070432-6****	1
2	51508GT	NUT,070110-6	1
3	51153GT	REDUCER,070123-6-4	1
4	65992GT	HOSE ASSEMBLY-OVRLOAD PROTE....1 <i>(to SN 17407) (components: 78855, 78855, 39887 @ 12 inches)</i>	1
4A	39494GT	HOSE ASSY,MNFLD TO ACCUMULATOR.....1 <i>(from SN 17408) (components: 78855, 78855, 39887 @ 10.75 inches)</i>	1
5	39518GT	CLAMP,2.00,#32 X 3/8,RUB CUSH.....1	1
6	6888GT	SCREW,HHC,1/4-20 X 1.....1	1
7	6638GT	WASHER,FLAT,USS,1/4"Y.....1	1
8	6091GT	NUT,NYLOCK,1/4-20.....1	1
9	51154GT	CONNECTOR,070103-4-4.....1	1
10	51151GT	SWITCH,PRESS 2500-6000 PSI ADJ....1	1
11		Ref. Bracket - Return Filter.....1 <i>(refer to Figure 209.1 or 209.2)</i>	1

505.1 Voltage Inverter

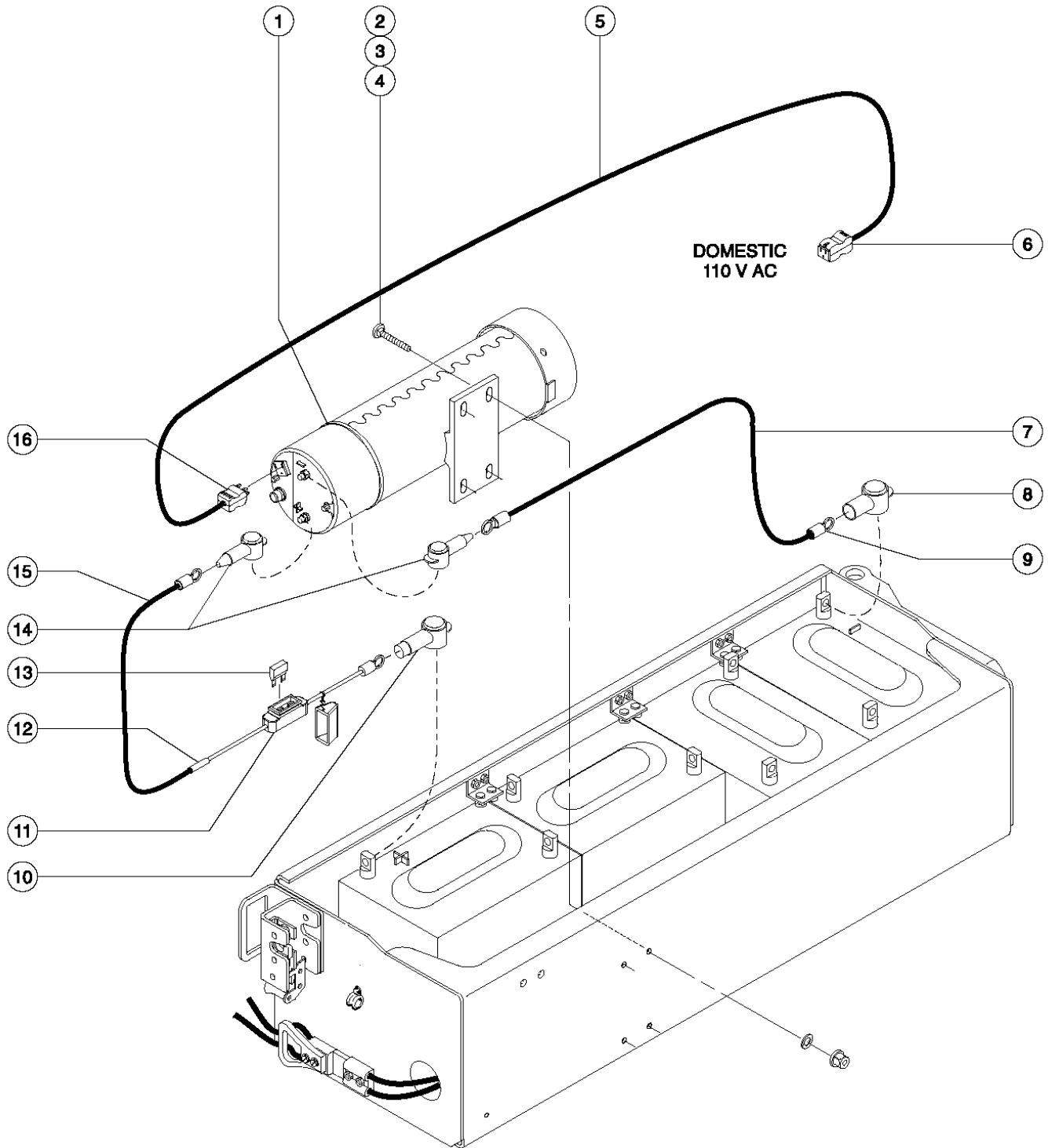



505.1 Voltage Inverter

Item	Part No.	Description	Qty.
--	51306GT	HARNESS,INVERTER GS32/GS46	
1		INVERTER <i>component no longer available</i>	
2	66218GT	BOLT,CARRIAGE,5/16-18 X 1.0,G2.....4	
3	6886GT	WASHER,LOCK,,313.....4	
4	6782GT	NUT,NYLOCK,5/16-18.....4	
5	43956GT	WIRE CABLE,14/3 CON.TPE JKT* .....144-inches (3.6 m)	
6	119404GT	CONN,RECEP 120AC/15A DOMESTIC.....1	
7	106208GT	WIRE,6 GA,BLACK,GXL.....35-inches	
8	51147GT	BOOT,CABLE TERMINAL,LG,RED,2/0...1	
9	55709GT	TERMINAL, 3/8" RING, #6GA.....4	
10	55748GT	BOOT,CABLE TERMINAL,SMALL.....1	
11	66808GT	FUSE/WIRE ASSY, GS46/GS2032.....1	
--	55747GT	FUSE HOLDER,INLINE,GS.....1	
12	66466GT	BUTT SPLICE, 6-GA.....1	
13	55726GT	FUSE,50 AMP.....1	
14	55748GT	BOOT,CABLE TERMINAL,SMALL.....2	
15	106207GT	WIRE,6 GA,RED,GXL.....1	
16	6595GT	PLUG,ELECTRICAL,DOMESTIC.....1	

506.1 Battery - Maintenance Free

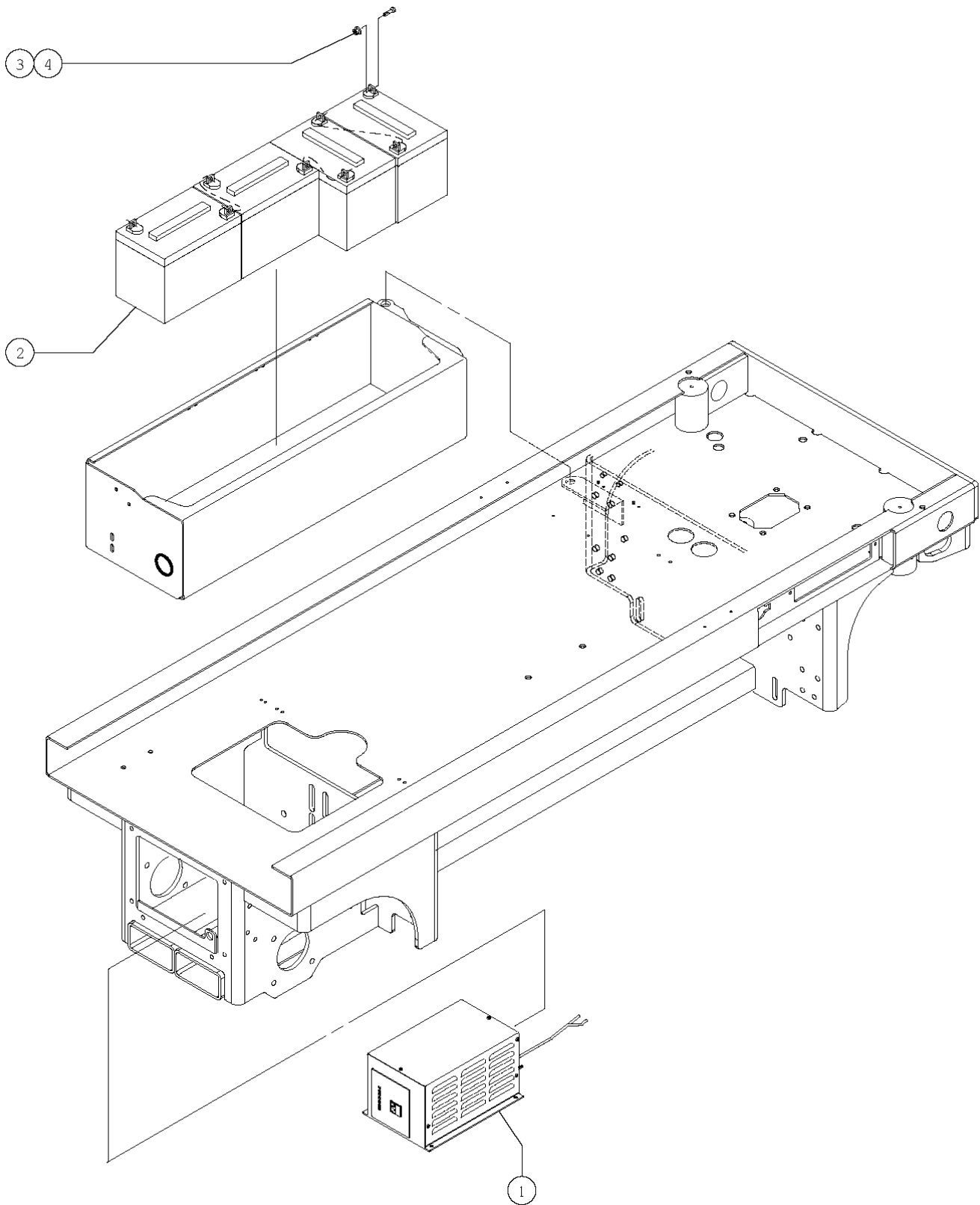

506.1 Battery - Maintenance Free

Item	Part No.	Description	Qty.
--	66380GT	CHARGER,MAINT. FREE-GS	
1		Ref. Battery Charger (refer to Figure 203.1, 203.2, 203.3 or 203.4)	
2	105150GT	BATTERY, AGM, 6V, (TROJAN) ***.....4	
3	18503GT	NUT,LOCKING-LG.FLANGE,5/16-18.....8	
4	10107GT	SCREW,HHC,5/16-18 X .75.....8	

507.1 Pipe Cradle Assembly

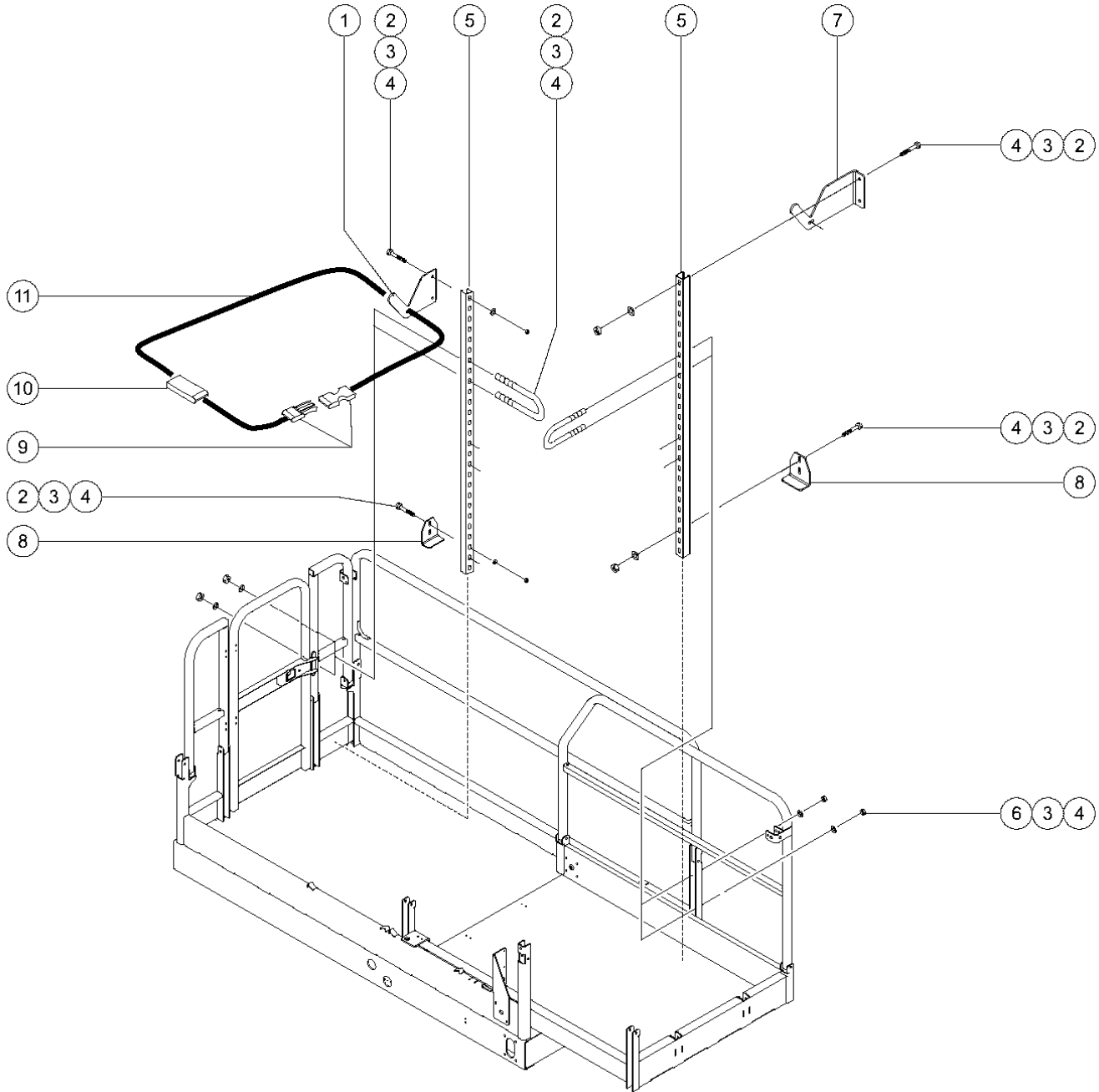

507.1 Pipe Cradle Assembly

Item	Part No.	Description	Qty.
--	66172-SGT	PIPE CRADLE ASSY. 2046/2646 ** <i>models with round rails</i>	
--	72878GT	PIPE CRDL,SQ RAILINGS,GS46 <i>models with square rails</i>	
1	79156GT	PLATE,PIPE HOLDER, GS68.....	1
2	14033GT	SCREW,HHC,3/8-16 X 2.75.....	8
3	6097GT	WASHER,FLAT,USS,3/8",Y.....	16
4	4828GT	NUT,NYLOCK,3/8-16.....	16
5	66171GT	CHANNEL,PIPE RACK.....	2
6	66472GT	U-BOLT, SQR, 3/8-16X2X5, PLTD..... <i>models with square rails</i>	4
6A	66216GT	U-BOLT,3/8-16X1.688X3.718,5PAK..... <i>models with round rails</i>	4
7	66169GT	FORMING, PIPE HOLDER RACK.....	1
8	79158GT	FORMING,PIPE RACK BASE, GS68.....	2
9	100810GT	BUCKLE & SLIDE STRAP SET.....	1
10	35643GT	BUCKLE,SIDE RELEASE.....	2
11	35642GT	STRAP,NYLON,1.0 IN. BLACK.....	96-inches

# Part Number Index

The Part Number Index is a numeric index of all part numbers included in this manual. The index shows what page(s) the part is used on.

Part Number	Page	Part Number	Page	Part Number	Page	Part Number	Page
100810GT	149	18963GT	137	39095GT	79, 81, 87, 89,	40832GT	51-52
10107GT	51-52, 55, 147	19273GT	55		95, 97, 103	40833GT	37, 39
104804GT	109	19284GT	37, 51-52, 55,	39127GT	79, 81, 87, 89,	40836GT	21, 23
105015GT	45		83, 91, 99, 101		95, 97, 103	40844GT	57
105109GT	135	19436GT	75, 77	39223GT	51-52, 71-72	41557-SGT	83, 91, 93, 99,
105115GT	135	19491GT	21, 23, 43, 45	39225GT	51-52, 55		101
105150GT	147	19506GT	65, 67	39226GT	51-52, 71-72	41630GT	33, 47, 111, 113,
105171GT	135	19710GT	133	39227GT	51-52, 55, 69		115
105172GT	135	19720GT	131	39232GT	21, 23	41695GT	43
105295GT	51-52, 123, 125	19722GT	131, 133	39240GT	17, 19	42019GT	51-52
105334GT	25, 31	19731GT	131	39250GT	17	42079GT	17, 19, 41
105390GT	57	19815GT	51-52	39271GT	41	42280GT	51-52
105454GT	17, 19, 41	19871GT	51-52	39301GT	51-52	43038GT	131
105457GT	59, 61, 63	19872GT	51-52	39310GT	105, 107, 109	43040GT	131
105580GT	71-72	20224GT	59, 61, 63, 69,	39317GT	43, 105, 107, 109	43089GT	12
105739GT	25, 29, 31		71-72	39347GT	59	43090GT	11-12
105801GT	71-72	20912GT	19	39429GT	111, 113, 117	43091GT	11-12
105907GT	75, 77	21121GT	83, 91, 93, 99	39438PGT	51-52, 55	43094GT	11-12
105908GT	77	21279GT	111, 113, 115	39448GT	111	43392GT	107, 109, 113,
105909GT	77	21427GT	133	39469GT	33, 47, 111, 113,		115
105910GT	77	21434GT	131, 133		115	43617GT	11-12
105911GT	75, 77	219480GT	25	39470GT	33, 47, 111, 113,	43618GT	11-12
105912GT	75, 77	219497GT	51-52, 55		115	43619GT	12
105914GT	75, 77	21982GT	65, 67	39474GT	105, 107, 109,	43658GT	11-12
105920GT	141	22446GT	109		111, 113, 115	43685GT	57
105921GT	141	23083-SGT	21, 23	39478GT	105, 111	43696GT	11-12
105971GT	141	233379GT	51-52, 55	39479GT	17, 19	43956GT	41, 117, 119, 145
105973GT	141	24514GT	111, 113, 115	39494GT	143	44166GT	59
105974GT	141	25388GT	25, 27, 41, 119	39518GT	51-52, 55, 143	44167GT	59
105975GT	141	27134GT	131	39520GT	51-52, 55	44168GT	59, 61, 63
10597GT	33, 35, 41, 47	27246GT	65, 67, 123	39521GT	51-52, 55	44169GT	59, 61, 63
105992GT	137	27262GT	25	39522GT	51-52	44170GT	59, 61, 63
106207GT	145	27488GT	21, 23	39523GT	51-52	44171GT	59, 61, 63
106208GT	145	27643GT	21, 23, 43, 45	39532GT	37, 47	44174GT	59, 61, 63
10775GT	117, 119	27894GT	139	39533GT	51-52	44175GT	59, 61
10777GT	119	27895GT	139	39540GT	21, 23	44176GT	59
119404GT	145	27900GT	139	39542GT	43, 45	44178GT	59
11966GT	37, 85, 93, 101	27901GT	139	39560GT	83, 85, 91, 93,	44207GT	52, 55
11968GT	111, 115	27902GT	139		99, 101	44216GT	41
12011GT	117	27903GT	139	39579GT	105, 107, 109,	44217GT	41
12017GT	25	27904GT	139		115	44218GT	41
12344GT	121	28161GT	11-12	39580GT	17, 43, 45, 49,	44220GT	11-12
12348GT	117	28164GT	11-12		55, 107	44224GT	41, 59
1257205GT	51-52	28171GT	11-12	39581GT	17, 19, 43, 45	44225GT	59, 61, 63
1263633GT	51-52	28174GT	11-12	39586GT	17, 19	44226GT	59, 61, 63
1263634GT	51-52, 55	28175GT	11-12	39608GT	105	44227GT	59, 61, 63
12906GT	37, 51-52, 55	28176GT	11-12	39612GT	15	44228GT	59, 61, 63
12960GT	23	28235GT	11-12	39654GT	105	44229GT	59, 61, 63
13000GT	35, 39, 49	28236GT	11-12	39673GT	51-52, 55	44230GT	59, 61, 63
13002GT	35, 37, 39, 49,	28443GT	83, 85, 91, 99,	39796GT	111, 113	44233GT	41
	51-52		141	39870GT	69	44235GT	41
13008-6GT	25	29868GT	23	39871GT	69	44236GT	59, 61
131426GT	103	31060GT	12	39872GT	69, 71-72	44244GT	75
13585GT	117, 119	31508GT	11-12	39873GT	69, 71-72	44250GT	17, 19
13635-10GT	19	31526GT	131	39874GT	69, 71-72	44254GT	11-12
13826GT	67	31785GT	11-12	39875GT	69, 71-72	44255GT	11-12
14033GT	41, 79, 81, 87,	32339GT	55	39876GT	69	44716GT	37
	89, 95, 97, 103,	33681GT	33, 47	39877GT	69, 71-72	44733GT	33, 47, 83, 91, 99
	105, 149	33724GT	119	39878GT	69, 71-72, 83,	44736GT	11-12
14041GT	23	33759GT	117		85, 91, 93, 99,	44737GT	11-12
14297GT	21, 119, 121	33784GT	141		101	44743GT	111, 113, 115
144011GT	141	34053GT	137	39879GT	69, 71-72	44750GT	57
144161GT	25, 27, 119	35461GT	111, 113, 115,	39880GT	69, 71-72	44751GT	57
144180GT	31		137	39883GT	69	44752GT	57
144421GT	77	35463GT	43, 45	39890GT	71-72	44753GT	11-12
150157GT	135	35642GT	149	39907GT	21, 23, 43, 45	44777GT	57
16439GT	83, 91, 99	35643GT	149	40265GT	43, 45	44778GT	57
18384GT	79, 81, 87, 89,	36388GT	105	40434GT	11-12	44780GT	17, 19, 41
	95, 97	36874GT	103	40536GT	25	44781GT	17, 19, 41
18503GT	37, 39, 147	37145GT	12	40537GT	25	44782GT	17, 19
18542GT	29	37947GT	65, 67	40552GT	75	44783GT	17, 19
18605GT	111, 113, 115,	38028GT	17, 19, 33, 35,	40594GT	43	44788GT	52, 55
	137		43, 45, 47, 49,	40766GT	117	44792GT	131
18666GT	37, 39		107, 113	40767GT	117	44973GT	83, 91, 93, 99,
18722GT	17, 19	39038GT	17, 19	40826GT	137		101

Part Number	Page	Part Number	Page	Part Number	Page	Part Number	Page
44979GT	83, 91, 93, 99, 101	47324GT	33, 35, 47, 49	48324GT	43, 45	52170GT	27, 29
44980GT	11-12	47325GT	33	48325GT	43, 45	52171GT	27
44988GT	131	47326GT	33	48326GT	43, 45	52172GT	27, 29
44994GT	11-12	47331GT	47	48327GT	43, 45	52173GT	27, 29
45071GT	83, 85, 91, 93, 99, 101	47342GT	33, 35, 47, 49	48331GT	11-12	52174GT	27
45226GT	83, 85, 91, 93, 99, 101	47363GT	52, 55, 111, 113, 137	48334GT	37, 39	52175GT	27
45385GT	21, 23	47374GT	107, 109, 111, 113, 115	48340GT	83, 91	52176GT	27
45437GT	117, 119	47389GT	111, 113	48344GT	79, 87, 89, 95, 97	5224GT	109, 115
45454GT	37, 39	47395GT	105	48345GT	79, 81, 87, 89, 95, 97	52266GT	79
45546GT	119	47414GT	43	48346GT	79, 81, 87, 89, 95	52267GT	81
45748GT	17, 19	47440GT	69	48347GT	79, 81, 87, 89, 95	52268GT	79
45840GT	105, 107, 109	47441GT	69, 71-72	48348GT	87, 89	52294GT	25
46216GT	61, 63	47442GT	69	48349GT	79, 81, 87, 89, 95	52326GT	81, 95, 97
46225GT	75	47442GT	69	48350GT	87, 89	52327GT	95, 97
46227GT	131	47455GT	33, 35, 47, 49	48351GT	81, 87, 89, 95, 97	52328GT	95, 97
46238GT	11-12	47458GT	83, 91, 99, 101	48352GT	17	52329GT	95, 97
46253GT	123	47464GT	17	48353GT	105	52330GT	95, 97
46254GT	123	47478GT	37, 39, 113, 115	48355GT	41	52331GT	95, 97
46260GT	111, 113, 115	47480GT	37, 39	48359GT	43, 45	52332GT	95, 97
46262GT	11-12	47502GT	83, 85, 91, 93, 99, 101	48371GT	137	52337GT	11-12
46266GT	123	47510GT	79, 81, 87, 89, 95, 97	48659GT	59, 63	52356GT	83, 91, 99
46267GT	123	47520GT	17, 19, 43	48664GT	75	52364GT	97
46268GT	131	47521GT	17	48665GT	75	52397GT	105
46269GT	131	47522GT	51-52, 55	48668GT	111	52398GT	105
46270GT	131	47523GT	105	48880GT	59, 61, 63, 69, 71-72	52399GT	105
46271GT	131, 133	47524GT	105	48997GT	59, 61, 63, 69, 71-72	52400GT	105
46272GT	131	47539GT	43, 45	49903GT	75	52400GT	11-12
46274GT	131	47540GT	43, 45	49904GT	75, 77	52494GT	11-12
46275GT	131	47541GT	43, 45	49906GT	75, 77	52525GT	133
46286GT	11-12	47547GT	17	50793GT	141	52527GT	133
46287GT	11-12	47548GT	17, 19, 33, 35, 43, 45, 47, 107	51063GT	21, 23, 43, 45	52529GT	133
46288GT	59, 61, 63	47566GT	83, 91	51144GT	79, 81, 87, 89, 95, 97	52561GT	11-12
46328GT	11-12	47593GT	43, 45	51146GT	43, 45	52562GT	11-12
46332GT	52, 55	47625GT	83, 91, 99	51147GT	37, 145	52563GT	11-12
46335GT	25	47630GT	69	51151GT	143	52594GT	61, 63
46337GT	25	47631GT	69	51152GT	143	52595GT	59, 61
46343GT	17	47633GT	69, 71-72	51153GT	143	52609GT	11-12
46347GT	33	47636GT	69	51154GT	143	52610GT	11-12
46348GT	47	47638GT	69	51288GT	25, 27	52864GT	15
47012GT	69, 83, 91, 99	47639GT	69	51290GT	111	5397GT	51-52, 55, 101, 113, 115
47046GT	83, 91, 99	47641GT	69	51306GT	145	55010GT	31
47094GT	111	47643GT	69, 71-72	51328GT	143	55018GT	31
47098GT	105, 111	47656GT	43, 45	51367GT	113, 115	55019GT	29, 31
47102GT	79, 81, 87, 89, 95, 97	47657GT	43, 45	51424GT	83, 91, 99	55021GT	31
47138GT	105, 107	47662GT	137	51496GT	35, 43, 45	55336GT	85, 93
47148GT	105	47663GT	137	51505GT	99	55350GT	21, 23
47160GT	103	47666GT	85, 93	51508GT	143	55351GT	83, 85, 91, 93, 99
47163GT	111, 113, 115	47670GT	69	51542GT	99	55355GT	19
47167PGT	111, 113	47676GT	137	51582GT	99	55488GT	85, 93, 101
47188GT	105	47679GT	137	51584GT	99	55537GT	113
47189GT	17	47680GT	137	51590	77	55560GT	83, 85, 91, 93, 99, 101
47190GT	17	47685GT	139	51592GT	21	55616GT	51-52, 55
47194GT	21	47686GT	139	51595GT	139	55620GT	27
47218GT	111, 113	47687GT	139	51596GT	85, 93, 99, 101	55709GT	145
47222GT	111, 113, 115	47785GT	105	51625GT	71-72	55717GT	83, 93
47225GT	111, 113, 115	47793GT	37, 39, 51-52, 55	51638GT	99	55725GT	21, 23
47227GT	33, 47, 111, 113, 115	47867GT	117, 121	51679GT	59	55726GT	145
47228GT	33, 47, 111	47892GT	137	51692GT	113, 115	55739GT	105, 107
47230GT	43, 45	47907GT	43	51742GT	121	55747GT	145
47232GT	23, 37, 39, 52, 55	47944GT	105	51743GT	121	55748GT	145
47243GT	43	47946GT	17, 19	51744GT	121	55789GT	55
47244GT	43	47955GT	83, 85, 91, 93, 99, 101	51763GT	79, 81, 87, 89, 95, 97	55837GT	71-72
47255GT	17, 33, 35, 43, 45, 47, 49, 113	48 28GT	139	51860GT	125, 127, 129	55856GT	51-52, 55
47274GT	43	48282GT	27	52042GT	131, 133	55898GT	107
47301GT	79, 81, 87, 89, 95, 97	4828GT	17, 19, 41, 43, 45, 79, 81, 83, 85, 87, 89, 91, 93, 95, 97, 99, 101, 103, 105, 107, 109, 111, 113, 115, 149	52043GT	131, 133	55906GT	115
47302GT	79, 81, 87, 89, 95, 97			52050GT	131, 133	55917GT	19
47322GT	43, 45			52084GT	11-12	55921GT	57
47323GT	33, 35, 47, 49			52157GT	121	55953GT	19
				52158GT	121	55967GT	71-72
				52168GT	27	55968GT	71-72
				52169GT	27	55983GT	33, 35, 47, 49
						55991-SGT	17
						55992-SGT	17
						56100GT	65, 67

## Part Number Index (continued)

Part Number	Page	Part Number	Page	Part Number	Page	Part Number	Page
56302GT	52, 55, 137	65058GT	12	66478GT	29	71706GT	31
56912GT	21, 41	65178GT	131, 133	66490GT	21, 23	71912GT	43, 45, 107
58000GT	83, 85, 91, 93	65179GT	133	66544GT	109	72084GT	11-12
58001GT	99, 101	65180GT	133	66666GT	29	72120GT	11-12
58128GT	91, 99	65184GT	61, 63	6666GT	25, 27, 41, 119	72254GT	125, 127
58148GT	85, 101	65297GT	123, 125	66683GT	101	72285GT	25
58230GT	25	65299GT	21, 23	66685GT	115, 127, 129	72326GT	21, 23, 125, 127, 129, 137
58293GT	131, 133	65318GT	55	66716GT	45	72833GT	11-12
58592GT	19	65430GT	121	66717GT	37, 39	72853GT	12
58914GT	123	65432-SGT	25	66750GT	19	72877GT	45
58973GT	137	65435GT	141	66761GT	65, 67, 123, 125	72878GT	149
58992GT	41	65439GT	141	66762GT	123	7339GT	83, 91, 93, 99, 101
58998GT	59, 61	6545GT	19	66765-3000GT	69, 71-72	74267GT	51-52
6002GT	35, 49, 111, 113, 115	65721GT	141	66772GT	61, 63	74468GT	51-52
6019GT	17, 19, 43, 45, 47, 85, 93, 101, 105, 107, 139	65734GT	65	66777GT	41	74469GT	51-52
6021GT	23, 52, 55, 57, 103, 111, 113, 115, 117, 127, 129	65736GT	51-52	66778GT	19	74470GT	51-52
6033GT	41	65763GT	41	66808GT	145	76502GT	37, 39
6035GT	19	65805GT	131	66811GT	67	77046GT	12
6036GT	113, 115	6595GT	25, 27, 41, 119, 145	66812GT	65, 67, 123, 125, 127, 129	7713GT	33, 37, 47, 83, 91, 99, 107, 111, 113, 115
60790GT	83	65962GT	61, 63	66813GT	21, 23, 123	78026GT	11-12
6086GT	33, 35, 43, 45, 47, 49	65971-SGT	35, 49	66814GT	67	78027GT	11-12
6090GT	23, 37, 39, 41, 105, 111, 113, 115	65972-SGT	35, 49	66815GT	123	78028GT	11-12
6091GT	19, 21, 23, 37, 39, 41, 43, 51-52, 83, 85, 91, 93, 99, 105, 109, 111, 113, 115, 117, 119, 121, 137, 143	65981GT	49	66816GT	67, 123	78038GT	109
6095GT	19	65982GT	35	66817GT	23, 65, 67, 123, 125, 127, 129	78044GT	17, 19
6097GT	17, 19, 23, 33, 37, 41, 43, 45, 47, 83, 85, 91, 93, 99, 101, 105, 111, 113, 115, 149	65987GT	115	66818GT	21, 65, 123, 125, 127, 129	78045GT	17, 19
6146GT	21, 43, 45	65990-SGT	109	66825GT	41	78055GT	45
6147GT	51-52, 55	65992GT	143	66829GT	19	78060GT	19
6175GT	17, 19, 23, 37, 41, 43, 83, 91, 99, 101	65993GT	97	66843GT	127	78070GT	17
6178GT	21, 23, 37, 43, 45, 51-52, 55, 137	66030GT	107, 109, 113, 115	66866GT	111, 113, 115	78075GT	17
6198GT	17, 19	6606GT	137	66871GT	35, 49	78076GT	17
62056GT	11-12	66094GT	39	66900GT	35, 49	78077GT	17, 19
62057GT	11-12	66152GT	125	66901GT	35, 49	78093GT	45
62058GT	11-12	66157GT	15, 129	66909GT	137	78098GT	55
62082GT	59, 61, 63	66158GT	125, 127	66945GT	71-72	78112GT	63
62161GT	133	66165GT	71-72	66960GT	77	78196GT	113, 119
62161HGT	133	66169GT	149	66961GT	77	78222GT	17, 19
62210GT	97	66171GT	149	66962GT	77	78313GT	51-52, 55
62223GT	125, 127, 129	66172-SGT	149	66963GT	77	78314GT	121
62227GT	113	66204GT	51-52, 55	66976GT	45	78422GT	55
62231GT	25	66205GT	71-72	66986GT	19	78464-SGT	25
62233GT	25	66206GT	57	66990GT	45	78546GT	51-52, 55
62234GT	25	66208GT	51-52, 55	6700GT	37, 47, 52, 55	78585GT	51-52, 55
62237GT	25	66216GT	149	6708GT	105	78622GT	52, 55
62858-SGT	25	66218GT	145	6782GT	33, 35, 39, 47, 49, 51-52, 55, 141, 145	78673GT	15
6356GT	17, 19, 21, 37, 39, 41, 51-52, 55, 83, 91, 93, 99, 101, 105	6626GT	119	6873GT	37	78674GT	23
6357GT	29, 37, 105	66283GT	72	68817GT	21	78686GT	83, 85, 91, 93, 101
64213GT	45	66284GT	72	68818GT	23, 67	78687GT	91, 93
64258GT	121	66353GT	119	6884GT	19	78688GT	101
65052GT	11-12	66355GT	119	6886GT	51-52, 111, 113, 141, 145	78698GT	55
		66356GT	119	6888GT	17, 19, 41, 55, 85, 93, 101, 113, 143	78716GT	77
		6637GT	109	6889GT	17, 37, 39, 51-52, 55, 83, 85, 91, 93, 99, 101, 111, 113, 115, 117	78725GT	52, 55
		66380GT	147			78736GT	19
		6638GT	37, 39, 41, 51-52, 55, 83, 85, 91, 93, 99, 109, 111, 113, 115, 137, 143	69229GT	141	78805GT	127
		66392GT	72	6935GT	21, 41, 117, 119	78864GT	69, 71-72
		66397GT	75, 77	69537GT	131	78876GT	69, 71-72
		66410GT	123	69580GT	29	78877GT	69
		66412GT	25	69581GT	29	78878GT	69, 71-72
		66427GT	37, 39	69582GT	29	78879GT	69, 71-72
		66430GT	43, 45	69583GT	29	78892GT	129
		66446GT	143	69584GT	29	78897GT	101
		66452GT	43, 45	69585GT	29	78900GT	101
		66453GT	43, 45	69586GT	29	78901GT	83
		66458GT	21, 23	7056GT	21, 41, 117, 119	78903GT	135
		66459GT	67	7127GT	119	78903HGT	135
		66462GT	23	71349GT	85, 93, 101	78904GT	129
		66465GT	83, 91, 93, 99, 101			78912GT	93
		66466GT	145			79156GT	149
		66470GT	85, 93, 101			79158GT	149
		66472GT	149			80220GT	65
						81579GT	137
						8177GT	33, 43, 45, 47, 49



Part Number	Page	Part Number	Page
8178GT	107, 109, 113, 115	97017GT	107
82051-SGT	115	97018GT	107
82052-SGT	109	97019GT	107
82053-SGT	109	97021GT	107
82054GT	109	97022GT	107
82055GT	109	97023GT	107
82056GT	109	97024GT	107
82057GT	115	97025GT	113
82058GT	113, 115	97026GT	113
82059-SGT	115	97028GT	105
82100-SGT	105, 115	97029GT	105
8220GT	41	97030GT	105
823408GT	51-52, 55	97031GT	105
82368GT	12	97032GT	105
8255GT	52, 55, 99, 107, 115, 127, 129	97033GT	105
83037GT	25	97055GT	51-52
83093GT	65, 67	97059GT	31
83126GT	123, 125	97124GT	117
84422GT	83, 91, 93, 99, 101	97134GT	107
84586GT	113, 115	97135GT	107
8514GT	37, 39, 55	97136GT	107
8516GT	83, 85, 91, 93, 99	97137GT	107
85197GT	57	97138GT	107
8538GT	17, 33, 47	97139GT	109
88000GT	41	97140GT	109
8914GT	21, 23, 51-52, 83, 85, 91, 93, 99, 111, 117, 137	97141GT	109
8915GT	37, 39	97142GT	109
94506GT	67	97143GT	109
96008-SGT	65, 67	97146GT	107
96009GT	65, 67	97147GT	107
96010GT	65, 67	97148GT	107
96011GT	65, 67	97149GT	107
96014GT	121	97150GT	107
96015GT	121	97151GT	107
96016GT	121	97152GT	107
96019GT	121	97153GT	109
96020GT	121, 129	97154GT	109
96110GT	37, 39	97155GT	109
96193GT	57	97157GT	109
96197GT	19	97159GT	109
96199GT	113, 115	97160GT	107
96214GT	25, 27, 29	97161GT	109
96236GT	119	97162GT	111
96246GT	113, 115	97163GT	107
96247GT	113, 115	97164GT	107
96257GT	41	97165GT	107
96317GT	17, 19	97166GT	109
96413GT	111, 113, 115	97168GT	109
96416GT	41	97169GT	107
96417GT	19	T112563GT	119
96419GT	19	T113787GT	113
96421GT	127, 129	T114691GT	67
96452GT	65, 67		
96461GT	41		
96948GT	21, 23, 43, 45		
97000GT	107		
97001GT	107		
97002GT	107		
97003GT	107		
97004GT	107		
97005GT	107		
97006GT	109		
97007GT	109		
97008GT	109		
97009GT	109		
97010GT	109		
97011GT	109		
97013GT	135		
97014GT	135		
97015GT	135		
97016GT	19		

## Part Description Index

The Part Description Index is an alphabetical index of all part descriptions included in this manual. The index shows what page(s) the part is used on.

### 2

24V,SYSTEM,E-DOWN GS3246.....21, 23

### A

ACCUMULATOR,180 PSI PRECHARGE\* .....55  
 A C T U A T R , S W I T C H , U N D E R  
 O V E R L A Y \* ~ .....125, 127  
 ADAPTER, HARNESS.....121, 129  
 ALARM ASSY.12VDC,ITT.....125, 127, 129  
 ALARM,INTERMITTENT TONE 6-30V\* .....137  
 ALARM,STEADY TONE\*\*\*.....21, 23  
 AMMETER, 39243/47906/66412.....25  
 AMMETER-47671 CHARGER,25 AMP .....27,  
 29  
 ARM, POTHOLE CRANK, GS32/46.....43, 45  
 ARM,L POTHOLE CRANK, GS32/46.....43, 45  
 ARM-#1 INNER W/DECALS GS2646.....79, 87,  
 89, 95, 97  
 ARM-#1 INNER W/DECALS, GS2046.....81  
 ARM-#1 OUTER W/BEARINGS GS2646.....79,  
 81, 87, 89, 95, 97  
 ARM-#2 INNER W/BEARINGS,GS2646.....79,  
 81, 87, 89, 95  
 ARM-#2 OUTER W/BEARINGS GS2646.....79,  
 81, 87, 89, 95  
 ARM-#3 INNER (GS-2046).....79  
 ARM-#3 INNER W/BEARINGS,GS2646.....87,  
 89  
 ARM-#3 INNER W/BEARINGS,GS3246.....95,  
 97  
 ARM-#3 OUTER (GS-2046).....79  
 ARM-#3 OUTER W/BEARING GS2646.....79,  
 81, 87, 89, 95  
 ARM-#3 OUTR,BATT.SIDE, GS3246.....95, 97  
 ARM-#3 OUTR,ENGINE SIDE,GS68.....97  
 ARM-#3 OUTR,GRN.CONTROL,GS3246...95,  
 97  
 ARM-#4 INNER W/BEARING,GS3268.....97  
 ARM-#4 INNER W/BEARINGS,GS2646.....87,  
 89  
 ARM-#4 INNER, GS3246.....95, 97  
 ARM-#4 OUTER W/BEARING GS2646.....81,  
 87, 89, 95, 97  
 ARM-#4 OUTR,BATT.SIDE, GS3246.....95, 97  
 ARM-#4 OUTR,GRN.CONTROL,GS3246...95,  
 97  
 ARM-#5 INNER W/BEARINGS,GS3246.....81,  
 95, 97  
 ARM-SINGLE OUTER, LEFT.....97  
 ASSY,RELAY SOCKET, AUTO.....137  
 ASSY,SWITCH,TOGGLE,SPDT\*\*\*\*\* .....67

### B

BALL STUD,GAS STRUT (38593)\*\*\* .....43, 45  
 Base - Push Button.....21  
 BASE WITH 1 NC CONTACT, E-STOP.....23,  
 65, 67, 123, 125, 127, 129  
 BASE, W/1 N.O. CONTACTS\*\*\* .....123  
 BASE,W/3 NC CONTACTS.....67  
 BASE,WITH 2 N.O. CONTACTS\*\*\* .....67  
 BATT CABLE ASSY-BATT.MOD, 2646.....75  
 BATT CABLE ASSY.CHASSIS-2646.....75  
 BATT.MODULE ASSY W/DECAL-2032.....37,  
 39

BATTERY CABLE ASSY 153" RED QD.....77  
 BATTERY CABLE ASSY 156" BLK QD.....77  
 BATTERY CABLE ASSY 25" RED QD.....77  
 BATTERY CABLE ASSY 75" BLK QD.....77  
 BATTERY CABLE ASSY,3.5" RED.....75  
 BATTERY CABLE ASSY,RED.....77  
 BATTERY CHARGER, CONT EUROPE.....29  
 BATTERY CHARGER,UPGRADE KIT\*\*\*.....25,  
 27, 29  
 BATTERY, AGM, 6V, (TROJAN) \*\*\* .....147  
 BATTERY,T105 W/LPT;3 CAP,DRY\*\*.....37, 39  
 BEARING,0.75IDX1.00ODX0.38L...17, 43, 45,  
 49, 55, 107  
 BEARING,0.75IDX1.00ODX0.50L...17, 19, 43,  
 45  
 BEARING,1.00IDX1.25ODX0.49L.....17, 19  
 BEARING,1.5IDX1.75ODX1.5L.....83, 85, 91,  
 93, 99, 101  
 BEARING,1.75IDX2.00ODX1.25L...79, 81, 87,  
 89, 95, 97  
 BEARING,2.25IDX2.50ODX1.50L\*.....17, 19  
 BEARING,DRIVE MOTOR GS15/19.....17, 19  
 BEARING,FL,.75IDX1.25ODX.5 L.....17  
 BEARING,FL,0.75ID X 1 OD X .49.....17, 19,  
 33, 35, 43, 45, 47, 107  
 BEARING,FL,1.75IDX2.25ODX.85L.....79, 81,  
 87, 89, 95, 97  
 BEARING,JOYSTICK (57890).....131  
 BEARING,MOTOR.....57  
 BEARING,MOTOR,36843,BRUSH END\*.....57  
 BELLCRANK,STEER W/BEARING 2646.....17  
 BLOCK, PLATFORM ANCHOR.....103  
 BLOCK,MODULE TRAY STOP.....43  
 BOLT, CARRIAGE, 3/8-16 X 1.50, G5.....83  
 BOLT, SHOULDER, LARGE FLANGE.....45  
 BOLT, WIDE SHOULDER.....17  
 BOLT,CARRIAGE,5/16-18 X 1.0,G2.....145  
 BOLT,CARRIAGE,5/16-18 X 2.0,G2.....141  
 BOLT,SHORT SHOULDER.....17, 33, 35, 43,  
 45, 47, 49, 113  
 BOLT,SHOULDER,5/8-11 X 1.19 LT.....43, 45,  
 107  
 BOOT, JOYSTICK~.....135  
 BOOT, PROTECTIVE, 45049 BLACK.....133  
 BOOT,CABLE TERMINAL COVER.....37, 39  
 BOOT,CABLE TERMINAL,LG,RED,2/0.....37,  
 145  
 BOOT,CABLE TERMINAL,SMALL.....145  
 BOOT,CONTROLLER.....131  
 BOOT,CONTROLLER\*\*.....133  
 BOOT,THUMB ROCKER\*\*\*.....135  
 BOOT,TOGGLE SWITCH,SHORT\*.....65, 67,  
 123  
 BOOT-THUMB ROCKER\*\* BLACK.....131  
 BOOT-THUMB ROCKER, 44988 RED\*\*.....131  
 BOX, GRAY SCISSOR CONTROLLERS.....123  
 BOX,INSTRUCTION STORAGE.....111, 113,  
 115  
 BOX,MOLDED UPPER CONTROL.....127, 129  
 BRACKET CABLE BRIDGE.....83, 91, 99  
 BRACKET, BATTERY MOUNTING.....21, 23  
 BRACKET, CONTROLLER MOUNT.....55  
 BRACKET, CONTROLLER MOUNT,SP.....57  
 BRACKET, COUNTERWEIGHT, GS3246....43,  
 45  
 BRACKET, RELAY MOUNTING.....51-52

BRACKET,BOX HINGE,LH-UP/RH-LO.....33,  
 35, 47, 49  
 BRACKET,BOX HINGE,RH-UP/LH-LO.....33,  
 35, 47, 49  
 BRACKET,CABLE BRIDGE,GS3246.....99  
 BRACKET,CONTROLLER MOUNT.....51-52  
 BRACKET,FILTER MOUNT.....51-52, 55  
 BRACKET,FOOT PEDAL SUPPORT.....111,  
 113  
 BRACKET,HINGE MOUNTING\*\*.....105  
 BRACKET,JOYSTICK QUICK DISCNT.....117,  
 121  
 BRACKET,LATCH SUPPORT.....105  
 BRACKET,LIMIT SWITCH.....21  
 BRACKET,LOCK PIN,LEFT.....33  
 BRACKET,LOCK PIN,RIGHT.....47  
 BRACKET,MAIN CABLE BRIDGE.....99  
 BRACKET,PLAT CONTROL BOX SLAB.....115,  
 127, 129  
 BRACKET,POTHOLE STOPPER,LEFT.....43,  
 45  
 BRACKET,POTHOLE STOPPER,RIGHT....43,  
 45  
 BRACKET,POTHOLE SWITCH.....43  
 BRACKET-LATCH MOUNT,BAT MOD.....35  
 BRACKET-LATCHMNT,PWR MOD  
 W/DEC.....49  
 BRAKE, HYDRAULIC\*\*\* .....41  
 BREATHER CAP, HYD. TANK, 1/4 NPT.....51-  
 52, 55  
 BRUSH,PWR UNIT (40844)\*\*.....57  
 BUCKLE & SLIDE STRAP SET.....149  
 BUCKLE,SIDE RELEASE.....149  
 BULKHEAD FITTING,PLASTIC X 8\*\*...51-52,  
 71-72  
 BULKHEAD,FEMALE X 6 X 6.....139  
 BULKHEAD,UNION,070601-6.....69  
 BUMPER, LINK.....85, 93, 101  
 BUMPER, MODULE TRAY.....37, 39, 51-52,  
 55  
 BUMPER,1.25 INCH O.D.,SCISSORS.....83,  
 85, 91, 93, 99, 101  
 BUMPER,BATTERY BOX & RAILS...107, 109,  
 113, 115  
 BUMPER,RUBBER.....43, 45  
 BUMPER,RUBBER,.63 X .63H.....105  
 BUMPER,RUBBER,.75 X .50H,STUD.....105  
 BUMPER,RUBBER,1"OD X .461 H.....37, 39,  
 113, 115  
 BUTT SPLICE, 6-GA.....145  
 BUTTON, .800 O.D. X .281.....111, 113, 115  
 BUTTON,JOYSTICK MOUNT,BRASS\*\*\*.....111,  
 113, 115  
 BUTTON,PUSH,BLACK W/SEAL \*\*\* .....21, 23,  
 123  
 BUTTON,PUSH,RED MUSHROOM  
 HEAD.....65, 67, 123, 125, 127, 129

### C

CABLE ASSEMBLY,11"(SCISSORS).....75  
 CABLE ASSEMBLY,13" BLACK.....75, 77  
 CABLE ASSEMBLY,13" RED.....75, 77  
 CABLE ASSEMBLY,13"(SCISSORS).....75  
 CABLE ASSEMBLY,9" RED.....75  
 CABLE BRACKET,PAINTED.....83, 91, 93, 99,  
 101

CABLE BRACKET,VERTICAL.....99  
 CABLE BRACKET,YOKE.....99  
 CABLE SQUEEZE CONN.,XTRA LRG.....23  
 CABLE TIE MOUNT.....83, 91, 99  
 CABLE TIE,11.5" BLACK.....83, 85, 91, 99, 141  
 CABLE TIE,4" BLK,HEAT RESISTNT....83, 91, 93, 99  
 CABLE,EMERGENCY DOWN.....21, 23  
 CAP, TUBE, SQ,1.25 X .083.....109  
 CAP,DIAGNOSTIC NIPPLE.....59, 61, 63, 69, 71-72  
 CAP,FINISHING,BLACK.....17  
 CAPACITOR, 4 MFD,660VAC,39243.....25  
 CAPACITOR,1.0 MFD.....51-52  
 CASE ASSEMBLY,47671 CHARGER.....27  
 CASE ASSY,BATT CHARGER (66478).....29  
 CASE ASSY-BATTERY CHRGR\*\*.....25  
 CASTING,45049, 40612.....131  
 CASTING-JOYSTICK, GS2032.....133  
 CAVITY PLUG,GRAY.....51-52  
 CHANNEL,PIPE RACK.....149  
 CHARGER MOUNT PLATE.....41  
 CHARGER,120VAC/60HZ,25A 24V\*\*\*.....25  
 CHARGER,BAT,24VDC,H/LO GEN2.....25, 29, 31  
 CHARGER,MAINT. FREE-GS.....147  
 CHARGER-BATT, DUAL VOLT\*\*.....27  
 Check Valve.....59, 61, 63  
 CHOCK STOP CUSHION.....85, 93  
 CIRCUIT BREAKER,50A,50VAC.....29  
 CIRCUIT BREAKER,7.0 AMP\*\*\*.....65, 67  
 CIRCUIT BREAKER-CHARGER, 8 AMP.....27, 29  
 CIRCUIT BREAKER-CHARGER,45 AMP.....27  
 CLAMP, CABLEBRIDGE,HALF.....83, 85, 91, 93, 99  
 CLAMP,0.75,#12 X 3/8,RUB CUSH\*.....37, 39  
 CLAMP,1.00,#16 X 1/4,RUB CUSH.....37, 39  
 CLAMP,1.31,#21 X 1/4,RUB CUSH.....141  
 CLAMP,1.75,#28 X 3/8,RUB CUSH.....55  
 CLAMP,2 HOSE,PLASTIC,5/8.....19  
 CLAMP,2.00,#32 X 3/8,RUB CUSH.....51-52, 55, 143  
 CLAMP,HOSE,.50.....51-52  
 CLAMP,HOSE,.75 \*\*.....55  
 CLAMP,HOSE,2 EAR, 5/8.....139  
 CLIP,CABLE TIE MOUNT.....83, 85, 91, 93, 99, 101  
 CNTRL CABLE(FEM/FEM) GS-2646\*\*.....121  
 CNTRL CABLE(FEM/FEM)GS-2046 \*\*.....121  
 COIL CORD ASSY,GS JOYSTICK\*\*\*.....123  
 COIL CORD,WORKLIGHT(144011).....141  
 COIL CORD-JOYSTICK, SLABS.....125, 127, 129  
 COIL,20V DS W/DIODE.....61, 63  
 COIL,20V DS W/DIODE,#10 SCISR.....59, 61  
 COIL,20V W/DIODE,#10 (SCI).....59  
 COIL,20V W/DIODE,#8 (SCI)\*\*\*.....59  
 COIL-SOLENOID VALVE,20V DC\*\*\*.....83, 91, 93, 99, 101  
 CONN,RECEP 120AC/15A DOMESTIC.....145  
 CONN,SQUEEZE,1/2NPT .38-.50,SM.....21, 41, 117, 119  
 CONNECTOR KIT,ITT CABLE/WIRE.....121  
 CONNECTOR, IEC CHARGER CORD.....25, 31  
 CONNECTOR,070102-8-8.....69  
 CONNECTOR,070103-4-4.....143  
 CONNECTOR,070120-4-4.....69, 71-72

CONNECTOR,070120-4-8.....69, 71-72  
 CONNECTOR,070120-6-10.....69, 71-72  
 CONNECTOR,070120-6-6.....69, 71-72, 83, 85, 91, 93, 99, 101  
 CONNECTOR,ANDERSON SB 175,1/0G...75, 77  
 CONNECTOR-IEC, BATT CHGR.....25  
 Contact - N.C.....23, 67  
 CONTACT,14-20GA.....51-52, 55  
 CONTACT,N.O.....67, 123  
 CONTACT,NC.....21, 65, 123, 125, 127, 129  
 CONTACTOR,DRIVE,24V,180A\*\*\*.....51-52  
 CONTACTOR,LIMIT SWITCH.....21, 23, 43, 45  
 CONTROL PANEL,LWR, GS46\*\*\*.....67  
 CONTROL PANEL-LOWER.....65  
 CONTROL-AVS, BATT CHGR.....25  
 CORD SET, AC (66412).....25  
 COUNTERWEIGHT, LARGE, GS32.....43, 45  
 COUPLER,1/4"SERIES 3/8 MPT.....139  
 COVER,BLANK.....119  
 COVER,GFCI,WEATHERPROOF.....117, 119  
 COVER,LOWER CONTROL PANEL \*\*\*.....21, 23  
 COVER-BATT CHGR.....25  
 COVER-BRUSH INSPEC.40844,SCISS.....57  
 CROSS TUBE COLAR, GS46\68.....85, 93, 101  
 CYL.ASSY,2046-3268.....85, 101  
 CYL.UPDATE GS-3246,3268.....91, 99  
 CYLINDER, GS2632/46/68\*\*\*.....83, 93  
 CYLINDER,STEERING GS15/GS19.....17, 19

**D**

DECAL DANGER TIP OVER TRAYS.....11-12  
 DECAL KIT-SFTY/INST,2032,2646.....11-12  
 DECAL, GROUND CONTROL PANEL \*\*\*.....11-12  
 DECAL, LABEL - DIRECTION ARROWS.....11-12  
 DECAL, LABEL, GS32/46.....12  
 DECAL, LABEL, LED READOUT.....11-12  
 DECAL, MANUAL LOWERING VALVE.....12  
 DECAL,CAUTION,CRUSH HAZ, RAILS.....11-12  
 DECAL,COSMETIC,GENIE GS-2046\*\*.....11-12  
 DECAL,COSMETIC,GENIE GS-2646.....11-12  
 DECAL,COSMETIC,GENIE GS-3246.....11-12  
 DECAL,DANGER DO NOT ALTER SWTC.....12  
 DECAL,DANGER,BATTERY SAFETY.....11-12  
 DECAL,DANGER,BRAKE REL SAFETY\*...11-12  
 DECAL,DANGER,CRUSHING HAZARD.....11-12  
 DECAL,DANGER,ELEC HAZARD,GS.....11-12  
 D E C A L , D A N G E R , E L E C T HAZARD,PLUG.....11-12  
 DECAL,DANGER,GENERAL SAFETY.....11-12  
 DECAL,DANGER,IMPROPER USE HAZ.....12  
 DECAL,DANGER,NO SMOKING \*\*\*.....11-12  
 DECAL,DANGER,TIP-OVER,BATTERY.....11-12  
 DECAL,DANGER,TIP-OVER,TILT.....11-12  
 DECAL,INSTRUCTIONS-OPER,GCP.....12  
 DECAL,JOYSTICK CONTROLLER.....15  
 DECAL,JOYSTICK\*\*.....15  
 DECAL,LABEL,DEXRON/FLUID LEVEL.....11-12  
 DECAL,LABEL,FAULT CODES.....11-12

DECAL,LABEL,MANUAL NOT HERE.....11-12  
 DECAL,LABEL,OPEN,LATCH.....11-12  
 DECAL,LABEL,PWR TO CHARGR 115 UK.....11-12  
 DECAL,LABEL,PWR TO CHARGR 230V....11-12  
 DECAL,LABEL,RYKON/FLUID LEVEL.....12  
 DECAL,LABEL,SAFETY ARM.....12  
 DECAL,LABEL,TRANSPORT TIEDOWN\*..11-12  
 DECAL,LABEL-TIRE SPECS.....11-12  
 DECAL,LANYARD ANCHORAGE POINT...11-12  
 DECAL,NOTICE, OPER INST, PCP.....11-12  
 DECAL,NOTICE,BATTERY CONNECT.....11-12  
 DECAL,NOTICE,CHARGER INSTRUC.....11-12  
 DECAL,NOTICE,ERROR LIGHT.....11-12  
 DECAL,NOTICE,HAZARDOUS MAT'LS\*....11-12  
 DECAL,NOTICE,MAX CAP 1000/250\*...11-12  
 DECAL,NOTICE,MAX CAP 1200/250.....11-12  
 DECAL,NOTICE,MAX CAP 500 ANSI\*.....11-12  
 DECAL,NOTICE,MAX CAP 700 ANSI.....11-12  
 DECAL,NOTICE,MAX CAP,2646 AU.....11-12  
 DECAL,NOTICE,MAXCAP,3246 AU/CE.....11-12  
 DECAL,NOTICE,SIDE FRC,2046ANSI.....11-12  
 DECAL,NOTICE,SIDE FRC,2046AUS.....11-12  
 DECAL,NOTICE,SIDE FRC,2646 AU.....11-12  
 DECAL,NOTICE,SIDE FRC,2646ANSI.....11-12  
 DECAL,NOTICE,SIDE FRC,2646CE.....11-12  
 DECAL,NOTICE,SIDE FRC,3246ANSI.....11-12  
 DECAL,NOTICE,SIDE FRC,3246AUS.....11-12  
 DECAL,NOTICE,SIDE FRC,3246CE.....11-12  
 DECAL,POWER TO PLATFORM 115V.....11-12  
 DECAL,POWER TO PLATFORM 230V.....11-12  
 DECAL,WARN,CRUSH HAZARD HAND...11-12  
 DECAL,WARN,IMPROPER OPERATION...11-12  
 DECK ASSY-EXTENSION, GS46.....113  
 DIAGNOSTIC FEMALE Q-DSCNT.....59, 61, 63, 69, 71-72  
 Diagnostic nipple.....59, 61, 63  
 DOG TAG, CONTROL BOX.....125  
 DRAW LATCH,OVER-CENTER\*\*\*.....111, 113  
 DRIVE MOTOR,18.3 CU. IN/REV.....19

**E**

E-DOWN HARNESS.....75, 77  
 ECM,SLAB,SERVICE\*\*\*.....51-52  
 ECU,SLAB,GEN4\*\*\*.....52, 55  
 ELBOW,070220-10.....71-72  
 ELBOW,070220-4-6.....69, 71-72  
 ELBOW,070220-6-6.....69, 71-72  
 ELBOW,070220-6-8.....69  
 ELBOW,070220-8-6.....69, 71-72  
 ELBOW,070701-6.....69  
 ELBOW,90DEG.....69  
 ELBOW,90ø,.5 MPT X.5BRB PLST.....51-52, 55

## Part Description Index (continued)

ENCLOSURE-LVL SENSOR W/DECAL\*\*...21, 23  
ENCODER W/PIGTAIL, 44988.....131

**F**

FILTER ASSY,SAE8,10 MIC,PAPR\*\*.....52, 55  
FILTER CAP (PLUG 1-1/2" NPT HEX...51-52, 55  
FILTER ELEMENT,10MICRON,PAPER\*.....52, 55  
FILTER ELEMENT,BETA(10)=200.....52, 55  
FITTING KIT-HYDRAULIC TANK.....55  
FIXED CONTACT (FOR 74267).....51-52  
FLANGE-JOYSTICK MOUNTING.....131  
FLANGE-JOYSTICK MOUNTING,44988.....131  
FLARE TUBE ASSY,LIFT CYLINDER.....69, 83, 91, 99  
Flow divider valve.....63  
Flow regulator valve.....59, 61, 63  
FOAM,CLOSED CELL 1.75X.250X18".....105  
FOOTPEDAL W/NON-SKID TAPE,GS\*\*.....111, 113, 115  
FORMING, CABLE BRIDGE, CENTER.....101  
FORMING, CABLE BRIDGE, UPPER.....91, 93  
FORMING, HAND PUMP BRACKET.....41  
FORMING, MOD TRAY HANDLE.....35, 49  
FORMING, PIPE HOLDER RACK.....149  
FORMING,BATTERY STOP.....37, 39  
FORMING,CABLE BRIDGE,GS3246/68.....101  
FORMING,CABLE BRIDGE,MAIN\*\*.....83, 85, 91, 93, 101  
FORMING,HOSE ROUTING.....19  
FORMING,HOSE ROUTING,BULKHEAD.....19  
FORMING, LEVEL SENSOR ENCLOSURE.....21, 23  
FORMING,PIPE RACK BASE, GS68.....149  
FORMING,SAFETY ARM\*\*.....83  
FUSE ASSY-BOOM CHARGER.....25  
FUSE BLOCK, ANN & ANL FUSE.....37, 39  
FUSE HOLDER,INLINE,GS.....145  
FUSE HOLDER,WATERPROOF.....21, 23  
FUSE,1 AMP.....21, 23  
FUSE,13 AMP,220V PLUG.....25, 27, 41  
FUSE,275 AMP,VERY FAST ACTING.....37, 39  
FUSE,50 AMP.....145  
FUSE,BATT CHGR.....25  
FUSE,BATTERY CHARGER\*\*.....31  
FUSE/WIRE ASSY, GS46/GS2032.....145

**G**

GAS SHOCK,SCISSORS\*\*.....43, 45  
GASKET, UK & DIN PWR. TO PLAT.....119  
GASKET, UK RECEPTACLE.....119  
GASKET-JOYSTICK.....133  
GATE-GS46 PLATFORM ENTRY.....109  
GATE-SWING FOLD DOWN ENT ASSY....107  
GEAR, SLAVE, MS4,45048.....131  
Genie GS-2646 models were produced using one of two different styles of control handles: one with a metal function enable switch lever,.....131  
GROMMET,RUBBER 2 X 2.75.....23, 37, 39, 52, 55  
GROUND STRAP.....37, 47  
GROUND STRAP,12"LG\*\*.....17, 19  
GS SLAB AC 2046 AIR TO PLAT.....139  
GS SLAB AC 2646 AIR TO PLAT.....139  
GS SLAB AC 3246 AIR TO PLAT.....139

GS SLAB AC BEACON.....137  
GS SLAB AC HORN.....137  
GS SLAB AC LD SENSOR (RLY).....143  
GS SLAB AC LOAD SENSOR.....143  
GS SLAB AC MOTION ALARM.....137  
GS46 EXT DECK-FOLD DOWN SQ.....115  
GS46 PLAT W/EXT COMPLETE\*\*.....105, 115

**H**

HANDLE ASSY,SEE58000-S/58001-S.....83, 91, 99  
HANDLE COVER,PLASTIC.....33, 47, 83, 91, 99  
HANDLE HALF SET-FOR 44988.....131  
HANDLE HALF,ENABLE SW.SIDE-GS.....131  
HANDLE HALF-BACKSIDE,GS JYSTK.....131  
HANDLE KIT,GS JYSTK,BOTH HALVE.....131, 133  
HANDLE,ANDERSON CONNECTOR SB.....37  
HANDLE,LOCK PIN,LT.....33  
HANDLE-LOCK,BATT.MOD,LEFT SIDE.....33  
HANDLE-LOCK,PWR MOD.RIGHT SIDE.....47  
HANDLE-ROTATOR LATCH ASSY LS\*\*.....35, 49  
HANDLE-ROTATOR LATCH ASSY RS\*\*.....35, 49  
HARNESS, GS46.....77  
HARNESS,ALARM ACCESSORY.....137  
HARNESS,BEACON ACCESSORY, SLAB.....137  
HARNESS,GS20/2646.....75, 77  
HARNESS,GS32/46.....77  
HARNESS,GS46.....77  
HARNESS,INVERTER GS32/GS46.....145  
HEATSINK ASSY W/DIODES (23442).....25  
HEATSINK-CNTRL ASSY,BATT CHGR.....25  
HINGE, SPRING, LONG LEG.....109  
HINGE, 4 X 4.....105  
HINGE,CLOSING (SPRING) 4 X 4.....105  
HORN HARNESS.....137  
HORN,24VDC,SPADE TERMINALS\*\*.....137  
HOSE ASSEMBLY-OVRLOAD PROTE.....143  
HOSE ASSY, FILTER/TANK GS32/46.....71-72  
HOSE ASSY, HANDPUMP/L BRAKE,46.....69, 71-72  
HOSE ASSY, HANDPUMP/R BRAKE,46.....69, 71-72  
HOSE ASSY, HYD. TANK/PUMP.....71-72  
HOSE ASSY, MAN TO LIFT, GS46.....71-72  
HOSE ASSY, MAN/ACCUM, MINI.....69, 71-72  
HOSE ASSY, MAN/HANDPUMP, 46.....69  
HOSE ASSY, MAN/STEER CYL, 46.....69, 71-72  
HOSE ASSY, TEE TO 1ST CYLIN.....72  
HOSE ASSY, TEE TO 2ND CYLIN.....72  
HOSE ASSY,BULKHEAD/DRIVE MOTOR.....69  
HOSE ASSY,DRIVE MOTORS,GS46.....71-72  
HOSE ASSY,FILTER/TANK GS32&46.....69  
HOSE ASSY,HYD.TANK/PUMP.....69  
HOSE ASSY,LIFT/MAN TO TEE FIT.....71-72  
HOSE ASSY,MANIFOLD/BULKHEAD.....69  
HOSE ASSY,MANIFOLD/FILTER.....69  
HOSE ASSY,MANIFOLD/HANDPUMP.....69, 71-72  
HOSE ASSY, MNFLD TO ACCUMULATOR.....143  
HOSE ASSY,MNFLD TO LIFT CYL.....69  
HOSE ASSY,MNFLD TO STEER CYL.....69, 71-72

HOSE ASSY,MNFLD. FILTER.....71-72  
HOSE ASSY,PUMP TO MANIFOLD.....69, 71-72  
HOSE END,BARBED SWIVEL,8,MALE.....71-72  
HOSE END,BARBED,RIGID,-6-6.....139  
HOSE END,BARBED,RIGID,90DEG6-6.....139  
HOSE END,FEM.SWIV,JIC 6-6.....71-72  
HOSE,LOW PRESSURE,,375 ID,BLK.....139  
HOUR METER,10-80 VOLTS\*\*.....65, 67  
HOUR METER,LCD,9-60 VDC\*\*.....65, 67  
HOUSING, LOCK PIN.....33, 47, 111, 113, 115  
HYDRAULIC TANK, GS46.....51-52, 55

**I**

IEC PIGTAIL\*\*.....25, 27  
INSERT, 3/8-16 X .5.....127  
INSTALLATION INSTRC.BEACON.....137  
INSTALLATION INSTRC.HORN.....137  
INSTALLATION INSTRCT.,ALARM.....137  
INSTRUCTIONS POTHOLE SRV KIT.....45  
INVERTER.....145

**J**

JOYSTIC HANDLE/SWITCH KIT.....135  
JOYSTICK CONTROLLER.....133  
JOYSTICK HANDLE SET, COMPLETE.....135  
JOYSTICK W/ENCODER CARD-GS.....131  
JOYSTICK,SINGL AXIS,HALL,SLAB\*.....135  
JOYSTICK,SINGL AXIS,POT,SLAB.....135

**K**

KEY SINGLE\*\*.....65, 67  
KEY,RECTANGULAR,,31X.28X1.25\*\*.....17, 19, 41  
KEY,SINGLE\*\*.....65, 67  
KEYS,10 PACK\*\*.....65, 67  
KEYSWITCH,3 POS. W/KEYS\*\*.....65, 67  
KEYSWITCH,3POS.MNTND.DR WKEY\*\*.....67  
KIT, GS MOTOR CONTROLLER REPL.....51-52, 55  
KIT, INVERTER JUMPER, GS.....51-52, 55  
KIT, KEYSWITCH\*\*.....65, 67  
KIT, PLATFORM PC RECEIPT/SOC.....135  
KIT,5 GALLON HYDRAULIC TANK\*\*.....51-52  
KIT,7.43 GAL - COMPLETE.....51-52, 55  
KIT,ACCUM 180 PSI PRECHARGE\*\*.....51-52, 55  
KIT,BATTERY CHARGER,24V.....25  
KIT,CONTACTOR,GS,ALT.....51-52, 55  
KIT,CONTROL BOX UPDATE,32/46.....123, 125  
KIT,DYN BRAKING VALVE,MINI.....59, 61, 63  
KIT,GASKET,UK POWER TO PLAT.....119  
KIT,GATE LATCH.....109  
KIT,GEN1 TO GEN5 CONTRL SYS\*\*.....51-52, 123, 125  
KIT,GS46 MOTOR CONTROLLER.....51-52  
KIT,JOYSTICK ENABLE SWITCH.....135  
KIT,JOYSTICK STEER SWITCH.....135  
KIT,ZERO CHARGER START SWITCH.....25  
KNOB,BLACK(44217)CHECK VALVE.....41  
KNOB,RED(44218)HP VALVE.....41

**L**

LADDER ASSY W/DECALS GS32/46\*\*.....41

LANYARD ROLLER BRKT ASSY W/DEC.....113, 115	NUT,NYLOCK,6-32.....121	PLAT MAIN ASSY GS2046 ANSI CSA.....107
LATCH ASSEMBLY-CONTROL BOX.....115	NUT,NYLOCK,8-32.....111, 113, 115, 137	PLAT MAIN ASSY GS2046 AUS.....107
LATCH HANDLE.....109	NUT,TOP LOCK,1/2-13.....41	PLAT MAIN ASSY GS2046 CE.....107
LATCH,ROTARY, W/KNOB, LEFT.....35, 49	NUT,WING 5/16-18.....141	PLAT MAIN ASSY GS2646 CE.....107
LATCH,ROTARY,W/KNOB,RIGHT.....35, 49	NUT-COIL SHORT.....59, 61, 63	PLAT MAIN ASSY GS3246 AUS.....107
LEVEL SENSOR,LS60,BLUE,2X3*.....23	N U T - M O U N T I N G , P U S H	PLAT MAIN ASSY GS3246 CE.....107
LEVEL SENSOR,LS60,BLUE,2X4*.....21, 23	BUTTON-44988.....131, 133	PLAT MAIN ASSY SQ GS2046 ANSI.....109
LEVER,FUNC ENABLE SWITCH,RGE**..131, 133	NUT-STRAIN RELIEF-GS JOYSTICK~.....123	PLAT MAIN ASSY SQ GS2046 AUS.....109
LEVER,FUNC.ENABL.SWITCH,METAL.....131	NUT-THIN HEAVY HEX, 1/4-20.....39	PLAT MAIN ASSY SQ GS2646 AUS.....109
LIGHT,REPLACEMENT BULB (39676).....137		PLAT MAIN ASSY SQ GS3246 ANSI.....109
LOCK, CONNECTOR.....31	<b>O</b>	PLAT MAIN ASSY SQ GS3246 CSA.....109
LOCKNUT,ELEC,1/2".....21, 41, 117, 119	O-RING,BOOT,CONTROLLER.....131	PLAT MAIN ASSY W/DECAL 2646ANS.....107
LOCKNUT,ELECTRIC,3/4".....23	Orifice.....59, 61, 63	PLAT MAIN ASSY W/DECAL 2646AUS.....107
LWR CONTROL PANEL COVER,GS3246.....23	ORIFICE DISC,.040".....59, 61, 63	PLAT MAIN ASSY W/DECAL 3246ANS.....107
	ORIFICE,LONG,.059".....83, 85, 91, 93, 99, 101	PLAT MAIN SQ ASSY GS2046 CE.....109
<b>M</b>	OUTLET,110V GFCI***.....117, 119	PLAT MAIN SQ ASSY GS2646 CE.....109
MANIFOLD MAIN VALVE,W/20 VDC*.....59	OVERLAY, PLAT CONTRL BOX,GEN4~.....15	PLAT MAIN SQ ASSY GS3246 AUS.....109
MANUAL BOX W/DECALS***.....111, 113, 115	OVERLAY,PLAT CONTROLLER SLAB.....15, 129	PLAT MAIN SQ ASSY GS3246 CE.....109
MANUAL,OWNERS,CHARGER,105739.....31		PLAT. ASSY.W/DECALS (GS2646).....105
MICROSWITCH-V319M***.....131, 133	<b>P</b>	PLAT.ASSY.W/DECAL ANSI/CSA.....105
MODULE TRAY ASSY-HYD PWR UNIT.....52, 55	PAD,BUMPER SUPPORT.....83, 91, 99	PLAT.ASSY.W/DECAL CE/AUS.....105
MOTOR CONTROLLER, DC,24V,300A.....51-52, 55	PC BOARD,PLAT CNTRL,SLAB.....125, 127	PLATE ENTRY GATE ASSEMBLY UPPER....107
MOTOR,ELECTRIC,24VDC 4.5HP.....57	PC BOARD,SLAB,GEN 4.....129	PLATE,AC ADAPTER,DIN/UK***.....119
MOVING CONTACT (FOR PN 74267).....51-52	PCB,ASSY,LED,GS JOYSTICK.....123	PLATE,AIRLINE TO PLAT, GS46.....139
	PCB,RELAY DRIVER,CHARGER 47671.....27	PLATE,HANDLE MOUNTING.....21
	PIN, LOCK.....33, 47, 111, 113, 115	PLATE,HOSE ROUTG,BULKHEAD(PTD).....19
	PIN, ROLLER.....113, 115	PLATE,HOSE ROUTING, BULKHEAD.....19
	PIN, THREADED ROLLER.....113, 115	PLATE,LIFT ARM CAM 1930,32,46.....83, 91
	PIN, WIRE LOCK 3/8 X 2 -1/2.....107, 109, 113, 115	PLATE,LIFT ARM CAM,GS-3246.....85, 93, 99, 101
		PLATE,PIPE HOLDER, GS68.....149
		PLATE,POTHOLE ACTUATOR,46.....43, 45
		PLATE,POTHOLE LINK,LWR.W/BUSH.....43, 45
		PLATE,POTHOLE LINK,UPR.W/BEARI.....43, 45
		PLATE,POTHOLE PAD SPACER, 32.....43
		PLATE,POTHOLE PIVOT W/BEARING.....43, 45
		PLATE,POTHOLE SPACER, GS46.....45
		PLATE-ENTY GATE ASSEMBLY LOWER.....107
		PLATFORM ASSY DECALS GS-3246.....105
		PLATFORM ASSY DECALS GS-3246CE...105
		PLATFORM ASSY DECALS GS2046 CE....105
		PLATFORM ASSY W/ DECALS,GS2046....105
		PLATFORM GATE WLDMENT GS46"W.....105
		PLATFORM LANYARD.....111
		PLATFRM CNTRLS W/DCLS 32/GS46.....123, 125
		PLATFRM EXT ASSY GS46.....111
		PLTFRM ASSY CMPLT, GS2046AUS.....109
		PLTFRM ASSY CMPLT, GS3246AUS.....107, 109
		PLTFRM ASSY COMLT, GS2046AUS.....107
		PLTFRM ASSY GS2646 AUS, ROUND.....107
		PLTFRM ASSY GS2646 AUS, SQ.....109
		PLTFRM ASSY W/DECAL GS3246 CE.....107
		PLUG,1/4"SERIES,3/8 MPT.....139
		PLUG,ELECTRICAL,220/500,NOVON....25, 27, 41, 119
		PLUG,ELECTRICAL,DOMESTIC....25, 27, 41, 119, 145
		PLUG,FUSED,250V,13AMP,U.K.**.....25, 27, 41, 119
		PLUG,HEX HEAD-8 PLASTIC....51-52, 55, 69
		PLUG,NYLON 1.12 BLACK DOMED.....21, 23

## Part Description Index (continued)

PLUG,NYLON 2.00 BLACK DOMED.....105, 107, 109	SCREW, HHC, 1/4-20 X .625.....21, 23, 51-52, 83, 85, 91, 93, 99, 111, 117, 137	SCREW,PHS,6-32 X 0.25.....121
PLUG,PWR,UK,16AMP,3PIN,BLK.....25, 27, 119	SCREW, HHC, 3/8-16 X .75.....52, 55, 99, 107, 115, 127, 129	SCREW,RHM,10-32 X .75.....137
PLUG,ROUND TUBING,1".....111, 113	SCREW, YOKE LOCK ALL SLABS.....19	SCREW,RHM,10-32 X 1.....51-52, 55
POTENTIOMETER (62161)***.....133	SCREW,BHHS,1/4-20 X .5,Y/ZINC.....117	SCREW,RHM,6-32 X .25.....25
POTENTIOMETER MOUNT PLATE.....133	SCREW,BHHS,1/4-20 X .75.....21, 119, 121	SCREW,RHM,6-32 X .5.....119
POTHOLE WELDMENT,LEFT,32/46.....43	SCREW,BHHS,1/4-20 X 1.....111, 115	SCREW,RHM,6-32 X .75.....117
POTHOLE WELDMENT,RIGHT,32.....43	SCREW,BHHS,1/4-20 X 1.5.....37, 85, 93, 101	SCREW,RHM,8-32 X .50.....52, 55, 111, 113, 137
POWER CORD, IEC 320 BLANK.....27	SCREW,BHHS,3/8-16 X 1.75.....111, 113, 117	SCREW,SHC,3/8-24 X 1.25".....57
POWER CORD, UK 110.....31	SCREW,BHHS,3/8-16 X 2.5.....103	SCREW,SHS,5/16-18 X .375.....33, 47, 111, 113, 115
POWER CORD,NOVON***.....29, 31	SCREW,BHSC,5/8-11 X 1.....113, 115	SCREW,TIMER,#8 PHMS X.375.....25
POWER CORD,UK-HIGH VOLTAGE***.....31	SCREW,CHARGER COVER,#10 X .5.....25	SEAL KIT (55717) TEXAS HYD VER.....85, 93, 101
POWER CORD,US 110***.....31	SCREW,FHM,10-32 X 1.....37	SEAL KIT (66419, 66416, 74297).....41
PUMP KIT,BOSCH,GS30***.....57	SCREW,FHS,1/4-20 X .25 NYLOCK.....51-52, 55	SEAL KIT, 48341 LIFT CYL.....83, 91
PUMP,4CC GEAR,CCW***.....57	SCREW,FHS,1/4-20 X .63...37, 51-52, 55, 83, 91, 99, 101	SEAL KIT, 55717 DY LIFT CYL.....93
PUSHBUTTON-FUNC.ENABL.W/ORING.131, 133	SCREW,FHS,1/4-20 X .75.....37, 39, 55	SEAL KIT, VALVE.....41, 59, 61, 63
	SCREW,FHS,1/4-20 X 1.25.....43	SEAL KIT,39909,PLAT LWR VALVE*.....83, 91, 93, 99, 101
	SCREW,FHS,3/8-16 X 1.....83, 91, 99	SEAL KIT,BOSCH PUMP***.....57
	SCREW,FHS,3/8-16 X 1.5.....43, 45	SEAL KIT,DR MTR.GS15/19,Z20***.....17, 19
	SCREW,FHS,3/8-16 X 2.25 ZN.....45	SEAL KIT,LIFT PUMP,BARNES**.....57
	SCREW,HEX INDENT,8-32 X 5/16.....29	SEAL KIT,RC SERIES DR MOTOR***.....19
	SCREW,HHC,1/2-13 X 1.25 GR5.....33, 35, 41, 47	SEAL KIT-FOR P.N.39038(SCISRS).....17, 19
	SCREW,HHC,1/2-13 X 1.375.....35, 43, 45	SEAL KIT-FOR P.N.44167.....59, 61, 63
	SCREW,HHC,1/2-13 X 1.5.....33, 43, 45, 47, 49	SEAL KIT-FOR P.N. 44217.....41
	SCREW,HHC,1/2-13 X 2.75.....17, 19	SEAL KIT-FOR P.N.44216 & 826779.....41
	SCREW,HHC,1/2-13 X 4.....41	SEAL KIT-P.N.44169,44172,44171.....59, 61, 63
	SCREW,HHC,1/4-20 X .75.....23, 37, 39, 41, 105, 111, 113, 115	SERIAL # LABEL,MYLAR 4X8***.....12
	SCREW,HHC,1/4-20 X 1.....17, 19, 41, 55, 85, 93, 101, 113, 143	SERV,BELLCRANK ASSY, GS46.....17, 19
	SCREW,HHC,1/4-20 X 1.25.....37, 39	SERVICE KIT, BATTERY STOP.....37, 39
	SCREW,HHC,1/4-20 X 1.75.....109	SERVICE KIT, BOM PLUG.....51-52, 55
	SCREW,HHC,1/4-20 X 2.5.....19	SERVICE KIT,BRAKE RELEASE MAN*.....41
	SCREW,HHC,3/8-16 X .625.....33, 47	SERVICE KIT,BRAKE,14.2 IN 3***.....41
	SCREW,HHC,3/8-16 X 1.....17, 19, 23, 37, 41, 43, 83, 91, 99, 101	SERVICE KIT,E-DOWN 3246.....123
	SCREW,HHC,3/8-16 X 1.25 GRD 5.....17, 19, 43, 45, 47, 85, 93, 101, 105, 107, 139	SERVICE KIT,E-STOP.....65, 67, 123, 125
	SCREW,HHC,3/8-16 X 1.50,GR5.....83, 85, 91, 93, 99	SERVICE KIT,FILTER,2032/46.....55
	SCREW,HHC,3/8-16 X 2.....109, 115	SHAFT ASSY, JOYSTICK***.....131
	SCREW,HHC,3/8-16 X 2 FULL THRD.....105, 111	SHAFT ASSY,JOYSTICK.....133
	SCREW,HHC,3/8-16 X 2.25.....105	SHUNT,ELECTRONIC,47671 CHARGER.....27
	SCREW,HHC,3/8-16 X 2.5.....107, 109, 113, 115	SLIDER BLOCK,PLATFORM.....103
	SCREW,HHC,3/8-16 X 2.75.....41, 79, 81, 87, 89, 95, 97, 103, 105, 149	SLIDER,BASE CHASSIS,46.....79, 81, 87, 89, 95, 97
	SCREW,HHC,5/16-18 X .50.....111	SNAP RING,EXTERNAL,1.75 DIA.....79, 81, 87, 89, 95, 97
	SCREW,HHC,5/16-18 X .75.....51-52, 55, 147	Solenoid valve.....59, 61, 63
	SCREW,HHC,5/16-18 X 1 GR5.....35, 37, 39, 49, 51-52	SPACER, .35ID X .785OD X .435.....141
	SCREW,HHC,5/16-18 X 1.25.....35, 39, 49	SPACER, POTHOLE ACTUATOR.....45
	SCREW,HHC,5/16-18 X 2.....141	SPACER,.75ID X 1.5OD X 1/4THK.....19
	SCREW,HHC,5/8-11 X 10.....43, 45	SPACER,.75IDX.875ODX.375.....43, 45
	SCREW,HHC,M5 X 6.....51-52	SPACER,EMERGENCY DOWN.....99
	SCREW,HHC,WASH HEAD,1/4-20X.63.....29	SPACER,MODULE TRAY,.030 THK.....33, 35, 47, 49
	SCREW,PHILLIPS,PHM,6-32 X .75.....119	SPACER,MODULE TRAY,.075 THK.....33, 35, 47, 49
	SCREW,PHILLIPS,PHM,8-32 X .5.....115	SPACER-DUAL COIL,#10, SCISSORS.....89, 61
	SCREW,PHILLIPS,PHM,8-32 X.25**.....65, 67	SPACER-DUAL COIL,#8***.....59, 61
	SCREW,PHILLIPS,PHM,8-32 X.375.....117	SPRING & BUSHING KIT,RETURN***.....131, 133
	SCREW,PHILLIPS,RHM,10-32 X 1.5.....21, 23, 43, 45	SPRING CLIP,1/4-20,.025-.15X.5, ZAG.....21, 41
	SCREW,PHM,4-40 X .38 PHIL.....117	SPRING CLIP,3/8-16,.05-20X.73,ZAG.....23
	SCREW,PHP, 8-32 X 5/8.....113, 119	SPRING, COMPRESSION.....29
		SPRING, RETURN (FOR 74267).....51-52
		SPRING, TORSION, ENTRY GATE.....105, 107
		SPRING,COMPRESSION .835 X 2.....109

## Q

QUICK DISCONNECT CASING,BATT\*\*.....75,  
77

## R

RAIL-EXT DECK,FOLDDOWN RS.....113  
RAIL-EXT, FOLD DOWN END\*\*.....113  
RAIL-GS46 EXT DECK.....115  
RAIL-GS46 EXT DECK\*\*.....113, 115  
RAIL-GS46 PLAT ENTRY, MAIN.....109  
RAIL-GS46 PLAT,MAINDECK LT\*\*\*.....109  
RAIL-GS46 PLAT,MAINDECK RT\*\*\*\*.....109  
RAIL-PLATFORM EXT DECK, LS.....113  
RAIL-PLATFORM, FOLDDOWN LS.....107  
RAIL-PLATFORM, FOLDDOWN RS\*\*.....107  
RAIL-SIDE, ENTRY GATE LS.....107  
RAIL-SIDE, ENTRY GATE RS\*\*\*.....107  
RAILING-PLAT EXT.W/DECALS,46".....111  
RECEPTACLE, DIN, 220V 50A.....119  
RECEPTACLE,ANTI-BACKOUT.....51-52, 55  
RECEPTACLE,FEMALE,36 CONTACT.....51-  
52, 55  
REDUCER,070123-6-4.....143  
Ref Function Manifold.....52  
RELAY,24VDC,40/30A,SEALED\*\*\*.....52, 55,  
137  
RELAY,24VDC,40/30A,SLD W/BRKT\*.....55  
RELAY,CHARGR,47671,DPDT,110VDC.....27  
Relief valve.....59, 61, 63  
RESISTOR, 75 OHM,DALE RS-10-38.....77  
RIVET,ALUM,STL,.188 X .250.....113  
RIVET,STL,STL,.188 X .45.....105, 107, 109,  
115  
RIVET,STL,STL,.188 X .50.....43  
ROCKER ASSEMBLY,45049.....131  
ROCKER ASSY W/ROLLPIN\*\*\*.....131, 133  
ROD END,.250 X 2.75 LG.....17, 19  
ROD END,.375 X 3.69.....83, 85, 91, 93, 99, 101  
ROLLER ARM-LIMIT SWITCH.....21, 23, 43, 45  
ROLLER BRKT ASSY W/DECAL.....117  
ROLLER,PLATFORM EXTENSION...111, 113,  
115

## S

SAFETY CHOCK,SCISSOR.....83, 85, 91, 93  
SAFETY CHOCK-SCISSOR.....99, 101  
SCR ASSY,47671 LESTER CHARGER.....27  
SCREW, HHC, 1/4-20 X .5.....83, 91, 93, 99,  
101

SPRING, COMPRESSION, 485 X 1.75\*\* .....33, 47, 111, 113, 115  
 SPRING, DIE 1.25 X 8.0.....43, 45  
 SPRING-BRUSH, 40844, SCISSORS.....57  
 SRV KIT, DRIVE MOTOR, GS32/46.....17, 19  
 SRV KIT, 32/46 STR. LINK ASSY, L.....17  
 SRV KIT, 32/46 STR. LINK ASSY, R.....17  
 SRV KIT, POTHOLE ACTUATOR, GS46.....45  
 STD MANIFOLD MAIN, GS32/46.....61, 63  
 STEER LINK ASSY GS46.....19  
 STEER LINK ASSY W/BRGS. GS2032.....17  
 STEERING, SRV KIT, GS2646/3246.....17  
 STOP PLATFORM ROLLER.....43, 105, 107, 109  
 STRAIN RELIEF-GS JOYSTICK\*\*~.....123  
 STRAINER ASSEMBLY.....51-52, 55  
 STRAP, NYLON, 1.0 IN. BLACK.....149  
 S T R O B E , B E A C O N , W / O U T  
 HARDWARE\*\*.....137  
 SVC KIT, UK RECEPT. REPLACEMENT.....119  
 SWITCH, LIMIT, W/ROLLER ARM\*\*\*.....21, 23, 43, 45  
 SWITCH, PRESS 2500-6000 PSI ADJ.....143  
 SWITCH, STARTER, LOW VOLTAGE.....25  
 SWITCH, TOGGLE, SPDT\*\*\*.....65

**T**

T-BOX, 2.75 X 4.5 X 2.0.....117, 119  
 TANK BREATHER, NYLON \*\*.....51-52  
 TANK ONLY, HYDRAULIC GS30/32\*\*\*.....51-52  
 TAPE, NON-SKID, DIE CUT, 1.38X1.5.....111, 113, 115  
 TAPE, NON-SKID, DIE CUT, 4" X 32".....107, 109, 111, 113, 115  
 TAPE, NON-SKID, DIE CUT, 4" X 40".....105, 111  
 TEE, RUN 070432-6\*\*\*\*\*.....143  
 TEE, RUN, 070428-4.....69, 71-72  
 TEE, RUN, 070428-6.....72  
 TERMINAL, 3/8" RING, #6GA.....145  
 TERMINAL, FEM. BUTT SEAM: 16/14.....67  
 TIMER ASSY, ELECTRONIC, 47671.....27, 29  
 TIMER ASSY, ELECTRONIC, DMSTC\*.....25  
 TOGGLE SWITCH, PREWIRED\*\*\*.....123  
 TRANSFORMER, CHARGER (66478).....29  
 TRANSFORMER, 47906, 66412, 39243.....25  
 TRIM LOCK, 1/8 X .75.....101  
 TUBE, CLAMP, 3/8 (PAIR).....19  
 TUBE, PLATFORM SPACER STD-12P.....29  
 TURN SWITCH ACTUATOR, JOYSTICK\*\*.....135

**U**

U-BOLT, SQR, 3/8-16X2X5, PLTD.....149  
 U-BOLT, 3/8-16X1.688X3.718, 5PAK.....149  
 U-BOLT, SQ BEND, 1/2-13.....19

**V**

VALVE, CHECK\*\*\*.....59, 63  
 VALVE, CHECK, 5 PSI\*\*.....59  
 VALVE, CHECK, IWP-S/CWP PWR ASSI.....61, 63  
 VALVE, CHECK, PILOT OPERATED\*\*\*.....41  
 VALVE, DBL PULL S-NOID 20V\*\*\*.....101  
 VALVE, FLOW DIVIDER/COMBINER.....63  
 VALVE, HAND PUMP\*\*.....41  
 VALVE, RELIEF, 1000PSI(SCISSORS).....59  
 VALVE, RELIEF, 3500PSI(SCISRS)\*.....59  
 VALVE, SHUTTLE.....41

VALVE, SOLENOID, 3POS 4WAY.....59, 61, 63  
 VALVE, W/20V NC SOLENOID, MANUAL.....83, 91, 93, 99, 101  
 VALVE-FLOW REGULATOR 0.75 GPM.....59, 61, 63  
 VALVE-RELIEF, 3700 PSI #8\*\*.....61, 63  
 VALVE-RELIEF, 130 PSI.....59, 61  
 VALVE-RELIEF, 1500 PSI, RV2.....61, 63  
 VALVE-SOLENOID N.O.(SCISSORS)\*.....59, 61, 63  
 VALVE-SOLENOID, 2POS 4 WAY.....59, 61, 63  
 VALVE-SOLENOID, 2POS 4WAY\*\*.....59, 61, 63

**W**

Warning - Compartment Access.....11-12  
 WASHER, LOCK, .25.....17, 19, 21, 37, 39, 41, 51-52, 55, 83, 91, 93, 99, 101, 105  
 WASHER, LOCK, .375.....23, 52, 55, 57, 103, 111, 113, 115, 117, 127, 129  
 WASHER, FENDER, .25 X 1.25 X .062.....37, 51-52, 55  
 WASHER, FINISHING CAP.....17  
 WASHER, FLAT, MS, #10, Y.....21, 43, 45  
 WASHER, FLAT, MS, #8, Y.....111, 113, 115, 137  
 WASHER, FLAT, USS, 1/2", Y.....19  
 WASHER, FLAT, USS, 1/4" Y.....37, 39, 41, 51-52, 55, 83, 85, 91, 93, 99, 109, 111, 113, 115, 137, 143  
 WASHER, FLAT, USS, 3/8", Y.....17, 19, 23, 33, 37, 41, 43, 45, 47, 83, 85, 91, 93, 99, 101, 105, 111, 113, 115, 149  
 WASHER, FLAT, USS, 5/16", Y.....51-52, 55, 101, 113, 115  
 WASHER, FLAT, USS, 5/8", Y.....19  
 WASHER, LOCK, .313.....51-52, 111, 113, 141, 145  
 WASHER, LOCK, .437, PLTD.....19  
 WASHER, LOCK, .625 PLTD.....113, 115  
 WASHER, LOCK, 0.5".....41  
 WASHER, LOCK, M5, PLTD.....51-52  
 WASHER, NITRILE.....65, 67  
 WASHER, NYLON, .406 X .750 X .032.....33, 47, 111  
 WASHER, SCIS ARM, 1.79X2.25X.120.....79, 81, 87, 89, 95, 97, 103  
 WASHER, SHOULDER, NYLON.....111, 113, 115  
 WASHER, STAR, EXTERNAL, .25.....29  
 WASHER, STAR, EXTERNAL, .375.....37, 47, 52, 55  
 WASHER, THRUST .75 X 1.25 X .06.....17, 19, 43  
 WASHER, THRUST 1 X 1.75 X .058.....17  
 WASHER, THRUST, .5 X 2.438 X .25.....17, 19  
 WEAR PAD, PLATFORM.....105, 107, 109, 111, 113, 115  
 WEAR PAD, POTHOLE.....43, 45  
 WEAR/GUIDE PAD MAIN PLATFORM.....105, 107, 109  
 WELDMENT STEERYOKE LH 32/46\*\*.....17  
 WELDMENT STEERYOKE RH 32/46\*\*\*.....17  
 WELDMENT, 3246 RETROFIT.....45  
 WELDMENT, ALUM, JOYSTICK GUARD.....111, 113  
 WELDMENT, LATCH, ENTRY GATE.....107  
 WELDMENT, COUNTERWEIGHT 575 LBS.....43, 45  
 WELDMENT, ENTRY GATE 32 \*\*.....105

WELDMENT, LH STEER YOKE, 32/46\*.....17, 19  
 WELDMENT, PLATFORM OUTLET.....111  
 WELDMENT, POTHOLE ACTUATOR, 46.....43, 45  
 WELDMENT, POTHOLE ARM, 32/46.....45  
 WELDMENT, RH STEER YOKE, 32/46\*.....17, 19  
 WELDMENT, ROLLER BRACKET, LT\*\*\*.....113, 115  
 WELDMENT, ROLLER BRACKET, RT\*\*\*.....113, 115  
 WELDMENT, SIDE RAIL.....105  
 WHEEL & TIRE ASSY LP, 15".....17, 19, 41  
 WIRE ASSEMBLY, GS2046.....121  
 WIRE ASSEMBLY, GS2646/2632.....121  
 WIRE ASSEMBLY, GS3246.....121  
 WIRE ASSY, CHASSIS CONTROL PIGT.....121  
 WIRE ASSY, GS2046.....121  
 WIRE ASSY, GS2646.....121  
 WIRE ASSY, GS3246.....121  
 WIRE CABLE, 14/3 CON. TPE JKT\*.....41, 117, 119, 145  
 WIRE CABLE, 18/2 SJO, BULK.....21, 23, 43, 45  
 WIRE CAP, ORANGE.....119  
 WIRE LOOM, SPIRAL, 1-5/8 ID 30".....69, 71-72  
 WIRE SEAL, GRAY.....51-52  
 WIRE, 6 GA, BLACK, GXL.....145  
 WIRE, 6 GA, RED, GXL.....145  
 WLDMT, LOCKING ROLLER SUPPORT...111, 113, 115  
 WORKLIGHT ACCES, GS2032/2046.....141  
 WORKLIGHT ACCES, GS2632/2646.....141  
 WORKLIGHT CABLE, GS19/20XX.....141  
 WORKLIGHT CABLE, GS26XX.....141  
 WORKLIGHT CABLE, GS32XX.....141  
 WORKLIGHT PIGTAIL ASSY.....141  
 WORKLIGHT, 24V, COIL CORD.....141

**Z**

ZERK-GREASE, 1/4-28, STRAIGHT.....19

## Fitting Cross References

Genie PN	Parker PN	Description	Genie PN	Parker PN	Description
12342	6-4 F5OX-S	CONNECTOR,STRAIGHT THREAD TO FLARE TUBE	42794	1 CR-S	ELBOW,90°,MALE PIPE
13757	4 R6X-S	RUN TEE,SWIVEL NUT,ORFS	42795	BV-0839	BALL VALVE
19685	12-10 C5OX-S	ELBOW,90°,STRAIGHT THREAD TO FLARE TUBE	42796	BV-0838	BALL VALVE
22664	12-10 C5OX	ELBOW,90°,STRAIGHT THREAD TO FLARE TUBE	42874	6-8 CLO-S	ELBOW,90°,MALE PIPE TO ORFS
27431	8-12 F5OX-S	CONNECTOR,STRAIGHT THREAD TO FLARE TUBE	42912	13943-6-4	HOSE END,90° FEMALE SWIVEL,JIC
28678	AS-B-33	SLEEVE,NYLON,1.81" ID	42920	BV-0840	BALL VALVE,90°
39871	6 WETX-WLN-S	UNION,90° BULKHEAD W/NUT,FLARE TUBE	42932	AS-B-17	SLEEVE,NYLON,1.22" ID
39872	4 R5OX-S	RUN TEE,STRAIGHT THREAD	42936	10243-2-4	HOSE END,FEMALE PIPE
39873	6 C5OX-S	ELBOW,90°,STRAIGHT THREAD TO FLARE TUBE	42953	1/2 DD-S	ELBOW,90°,FEMALE PIPE
39874	8-6 C5OX-S	ELBOW,90°,STRAIGHT THREAD TO FLARE TUBE	42956	6 WELO-WLNL-S	UNION,90° BULKHEAD W/NUT,ORFS
39875	4-6 C5OX-S	ELBOW,90°,STRAIGHT THREAD TO FLARE TUBE	45349	8 V5OX-S	ELBOW,45°,STRAIGHT THREAD TO FLARE TUBE
39876	6-8 C5OX-S	ELBOW,90°,STRAIGHT THREAD TO FLARE TUBE	45351	4 V5OX-S	ELBOW,45°,STRAIGHT THREAD TO FLARE TUBE
39877	4 F5OX-S	CONNECTOR,STRAIGHT THREAD TO FLARE TUBE	47223	10343-6-6	HOSE END,MALE,JIC
39878	6 F5OX-S	CONNECTOR,STRAIGHT THREAD TO FLARE TUBE	47419	PS690503-6-6	SWIVEL,90°,STRAIGHT THREAD TO 37° FLARE
39879	4-8 F5OX-S	CONNECTOR,STRAIGHT THREAD TO FLARE TUBE	48750	421-4	HOSE,1/4 INCH ID
39880	6-10 F5OX-S	CONNECTOR,STRAIGHT THREAD TO FLARE TUBE	48751	481TC-4	HOSE,1/4 INCH ID
39881	4-6 F5OX-S	CONNECTOR,STRAIGHT THREAD TO FLARE TUBE	48752	482TC-4	HOSE,1/4 INCH ID
39882	4-HP5ON-S	PLUG,STRAIGHT THREAD	48753	451TC-6	HOSE,3/8 INCH ID
39883	8-8 FTX-S	CONNECTOR,MALE PIPE TO FLARE TUBE	48754	482TC-6	HOSE,3/8 INCH ID
39885	269HB 12-12	ELBOW,90°,BEADED HOSE BARB TO MALE PIPE	48755	381-6	HOSE,3/8 INCH ID
39886	431-6	HOSE,3/8 INCH ID	48756	451TC-8	HOSE,1/2 INCH ID
39887	540N-2	HOSE,1/8 INCH ID	48757	482TC-8	HOSE,1/2 INCH ID
39888	801-8	HOSE,1/2 INCH ID	48758	381-8	HOSE,1/2 INCH ID
39889	801-12	HOSE,3/4 INCH ID	48759	381-10	HOSE,5/8 INCH ID
39890	10643-6-6	HOSE END,FEMALE SWIVEL,JIC	48760	451TC-10	HOSE,5/8 INCH ID
39891	13943-6-6	HOSE END,90° FEMALE SWIVEL,JIC	48761	482TC-12	HOSE,3/4 INCH ID
39892	13743-6-6	HOSE END,45° FEMALE SWIVEL,JIC	48762	451TC-12	HOSE,3/4 INCH ID
39894	30682-8-8	HOSE END,FEMALE SWIVEL,JIC	48763	772-12	HOSE,3/4 INCH ID
39895	30682-10-12	HOSE END,FEMALE SWIVEL,JIC	48764	881-16	HOSE,1 INCH ID
42286	8-8 CTX-S	ELBOW,90°,MALE PIPE TO FLARE TUBE	48765	772-16	HOSE,1 INCH ID
42756	8-12 CLO-S	ELBOW,90,MALE PIPE TO ORFS	48766	AS-B-15	SLEEVE,NYLON,1.06" ID
42757	8-12 FLO-S	CONNECTOR,MALE PIPE TO ORFS	48767	AS-B-22	SLEEVE,NYLON,1.42" ID
42758	4 JLO-S	UNION TEE,ORFS	48770	881-8	HOSE,1/2 INCH ID
42759	4-4 FLO-S	CONNECTOR,MALE PIPE TO ORFS			
42760	6-8 FLO-S	CONNECTOR,MALE PIPE TO ORFS			
42761	1J143-6-4	HOSE END,90° FEMALE SWIVEL,SEAL LOK			
42762	1J743-6-4	HOSE END,45° FEMALE SWIVEL,SEAL LOK			
42768	1JO43-4-4	HOSE END,MALE,SEAL LOK			
42776	601-8	HOSE,1/2 INCH ID			
42777	1J743-16-16	HOSE END,45° FEMALE SWIVEL,SEAL LOK			
42786	16 CLO-S	ELBOW,90°,MALE PIPE TO ORFS			
42787	16 R6LO-S	RUN TEE,SWIVEL NUT,ORFS			
42788	16-8 TRLO-BL-S	REDUCER,TUBE END TO SWIVEL,ORFS			
42789	6-6 CLO-S	ELBOW,90°,MALE PIPE TO ORFS			
42790	8-10 V5OLO-S	ELBOW,45°,STRAIGHT THREAD TO ORFS			
42791	3/4 CD-S	ELBOW,90°,MALE TO FEMALE PIPE			
42792	3/4 X 1/2 PTR-S	REDUCER,MALE TO FEMALE PIPE			
42793	1/2 CR-S	ELBOW,90°,MALE PIPE			



Fitting Cross References (Continued)

Genie PN	Parker PN	Description
48771	881-10	HOSE,5/8 INCH ID
48772	381-4	HOSE,1/4 INCH ID
48773	AS-B-13	SLEEVE,NYLON,.86" ID
48800	1JC43-4-4	HOSE END,FEMALE SWIVEL,SEAL LOK
48801	1J743-4-4	HOSE END,45° FEMALE SWIVEL,SEAL LOK
48802	1J943-4-4	HOSE END,90° FEMALE SWIVEL,SEAL LOK
48804	1JM43-4-4	HOSE END,MALE,SEAL LOK, NO O-RING
48805	10643-4-4	HOSE END,FEMALE SWIVEL,JIC
48806	13943-4-4	HOSE END,90° FEMALE SWIVEL,JIC
48807	1JS43-4-4	HOSE END,FEMALE SWIVEL,SEAL LOK
48808	3JC82-8-8	HOSE END,FEMALE SWIVEL,SEAL LOK
48809	3JC82-12-12	HOSE END,FEMALE SWIVEL,SEAL LOK
48810	1JC43-6-4	HOSE END,FEMALE SWIVEL,SEAL LOK
48811	1J943-6-4	HOSE END,90° FEMALE SWIVEL,SEAL LOK
48812	1JC43-6-6	HOSE END,FEMALE SWIVEL,SEAL LOK
48813	1J143-6-6	HOSE END,90° FEMALE SWIVEL,SEAL LOK
48814	1J543-6-6	HOSE END,90° FEMALE SWIVEL,SEAL LOK
48815	1J743-6-6	HOSE END,45° FEMALE SWIVEL,SEAL LOK
48816	1J943-6-6	HOSE END,90° FEMALE SWIVEL,SEAL LOK
48817	1JS43-6-8	HOSE END,FEMALE SWIVEL,SEAL LOK
48818	1J943-8-4	HOSE END,90° FEMALE SWIVEL,SEAL LOK
48819	1JC43-8-6	HOSE END,FEMALE SWIVEL,SEAL LOK
48820	1J743-8-6	HOSE END,45° FEMALE SWIVEL,SEAL LOK
48821	1J943-8-6	HOSE END,90° FEMALE SWIVEL,SEAL LOK
48822	1JC43-8-8	HOSE END,FEMALE SWIVEL,SEAL LOK
48823	1JS43-8-8	HOSE END,FEMALE SWIVEL,SEAL LOK
48824	1J143-8-8	HOSE END,90° FEMALE SWIVEL,SEAL LOK
48825	1J543-8-8	HOSE END,90° FEMALE SWIVEL,SEAL LOK
48826	1J743-8-8	HOSE END,45° FEMALE SWIVEL,SEAL LOK
48827	1J943-8-8	HOSE END,90° FEMALE SWIVEL,SEAL LOK
48828	1JC43-10-8	HOSE END,FEMALE SWIVEL,SEAL LOK
48829	1JS43-10-8	HOSE END,FEMALE SWIVEL,SEAL LOK
48830	1J743-10-8	HOSE END,45° FEMALE SWIVEL,SEAL LOK
48831	1J943-10-8	HOSE END,90° FEMALE SWIVEL,SEAL LOK
48833	1JC43-10-10	HOSE END,FEMALE SWIVEL,SEAL LOK
48834	1J943-10-10	HOSE END,90° FEMALE SWIVEL,SEAL LOK
48835	1JS43-10-12	HOSE END,FEMALE SWIVEL,SEAL LOK
48836	1JC43-12-8	HOSE END,FEMALE SWIVEL,SEAL LOK
48837	1JS43-12-8	HOSE END,FEMALE SWIVEL,SEAL LOK
48838	1J743-12-8	HOSE END,45° FEMALE SWIVEL,SEAL LOK
48839	1J943-12-8	HOSE END,90° FEMALE SWIVEL,SEAL LOK
48840	1J943-12-10	HOSE END,90° FEMALE SWIVEL,SEAL LOK
48841	1JC43-12-12	HOSE END,FEMALE SWIVEL,SEAL LOK
48842	1JO43-12-12	HOSE END,MALE,SEAL LOK
48843	1J143-12-12	HOSE END,90° FEMALE SWIVEL,SEAL LOK
48844	1J543-12-12	HOSE END,90° FEMALE SWIVEL,SEAL LOK
48845	1J743-12-12	HOSE END,45° FEMALE SWIVEL,SEAL LOK
48846	1J943-12-12	HOSE END,90° FEMALE SWIVEL,SEAL LOK

Genie PN	Parker PN	Description
48847	13943-12-12	HOSE END,90° FEMALE SWIVEL,JIC
48848	10543-12-12	HOSE END,MALE,STRAIGHT THREAD
48849	1JC71-12-12	HOSE END,FEMALE SWIVEL,SEAL LOK
48850	1JS71-12-12	HOSE END,FEMALE SWIVEL,SEAL LOK
48851	1J171-12-12	HOSE END,90° FEMALE SWIVEL,SEAL LOK
48852	1J771-12-12	HOSE END,45° FEMALE SWIVEL,SEAL LOK
48853	1J971-12-12	HOSE END,90° FEMALE SWIVEL,SEAL LOK
48854	1JC43-16-16	HOSE END,FEMALE SWIVEL,SEAL LOK
48855	1J943-16-16	HOSE END,90° FEMALE SWIVEL,SEAL LOK
48856	1J171-16-16	HOSE END,90° FEMALE SWIVEL,SEAL LOK
48857	1J971-16-16	HOSE END,90° FEMALE SWIVEL,SEAL LOK
48859	1JS43-8-4	HOSE END,FEMALE SWIVEL,SEAL LOK
48867	PD36BTL	DIAGNOSTIC NIPPLE,SEAL-LOK SWIVEL
48873	6 PNLO-S	PLUG,TUBE END,ORFS
48874	6 PNTX-S	PLUG,FLARE TUBE
48875	6 R6LO-S	RUN TEE,SWIVEL NUT,ORFS
48877	4 F5OLO-SW/.025	CONNECTOR,STRAIGHT THREAD TO ORFS, W/.025 ORI
48878	16-12 C5OLO-S	ELBOW,90°,STRAIGHT THREAD TO ORFS
48879	8 C6LO-S	ELBOW,90°,SWIVEL NUT ORFS
48880	PD6-285	CAP,DIAGNOSTIC NIPPLE
48881	6 HLO-S	UNION,ORFS
48883	8 P5ON-S	PLUG,STRAIGHT THREAD
48884	8M18F87OMLO-S	CONNECTOR,METRIC,STRAIGHT THREAD TO ORFS
48885	4 WGTX-WLN-S	CONNECTOR,BULKHEAD,FEMALE PIPE TO FLARE TUBE
48886	4 F5OLO-SW/2MM	CONNECTOR,MACHINED STRAIGHT THREAD TO ORFS
48887	4 CTX-S	ELBOW,90°,MALE PIPE TO FLARE TUBE
48888	10-12 V5OLO-S	ELBOW,45°,STRAIGHT THREAD TO ORFS
48890	4 S5OLO-S	BRANCH TEE,STRAIGHT THREAD TO ORFS
48891	4 S6LO-S	BRANCH TEE,SWIVEL NUT TO ORFS

## Fitting Cross References (Continued)

Genie PN	Parker PN	Description	Genie PN	Parker PN	Description
48892	6 C6LO-S	ELBOW,90°,SWIVEL NUT ORFS	48938	8 R6LO-S	RUN TEE,SWIVEL NUT,ORFS
48893	6 F5OHAO-S	UNION,STRAIGHT THREAD	48939	8 S6LO-S	BRANCH TEE,SWIVEL NUT TO ORFS
48894	8 WLO-WLNL-S	UNION,BULKHEAD,ORFS	48940	8 WJLO-WLNL-S	RUN TEE, BULKHEAD,ORFS
48895	DT-370-MSMO-5	VALVE,CHECK	48941	8-4 TRLO-S	REDUCER,TUBE END TO SWIVEL,ORFS
48896	6 JLO-S	UNION,TEE,ORFS	48942	8-6 C5OLO-S	ELBOW,90°,STRAIGHT THREAD TO ORFS
48897	DT-750-MSMS-5	VALVE,CHECK	48943	8-6 F5OLO-S	CONNECTOR,STRAIGHT THREAD TO ORFS
48898	DT-750-MOMS-5	VALVE,CHECK	48944	8-8 FLO-S	CONNECTOR,MALE PIPE TO ORFS
48899	DT-620-MOMS-5	VALVE,CHECK	48945	8 FTX-S	CONNECTOR,MALE PIPE TO FLARE TUBE
48900	4-6 F5OLO-SW/.035	CONNECTOR,STRAIGHT THREAD TO ORFS, W/.035 ORI	48946	8-10 F5OLO-S	CONNECTOR,STRAIGHT THREAD TO ORFS
48902	16-1 AOE4G-S	ELBOW,90° LONG,FEMALE PIPE TO STRAIGHT THREAD	48947	8-12 C5OLO-S	ELBOW,90°,STRAIGHT THREAD TO ORFS
48903	1 FF-S	NIPPLE,PIPE	48948	8-12 F5OLO-S	CONNECTOR,STRAIGHT THREAD TO ORFS
48904	4 C5OLO-S	ELBOW,90°,STRAIGHT THREAD TO ORFS	48949	8-16 F5OLO-S	CONNECTOR,STRAIGHT THREAD TO ORFS
48905	4 F5OLO-S	CONNECTOR,STRAIGHT THREAD TO ORFS	48950	10 C5OLO-S	ELBOW,90°,STRAIGHT THREAD TO ORFS
48906	4 R5OLO-S	RUN TEE,STRAIGHT THREAD	48951	10 CC5OLO-S	ELBOW,90° LONG,STRAIGHT THREAD TO ORFS
48907	4 V5OLO-S	ELBOW,45°,STRAIGHT THREAD TO ORFS	48952	10 F5OLO-S	CONNECTOR,STRAIGHT THREAD TO ORFS
48908	4 R6LO-S	RUN TEE,SWIVEL NUT,ORFS	48953	10 R5OLO-S	RUN TEE,STRAIGHT THREAD
48909	4 WJLO-WLNL-S	RUN TEE, BULKHEAD,ORFS	48954	10 S5OLO-S	BRANCH TEE,STRAIGHT THREAD TO ORFS
48910	4 GTX-S W/.030	CONNECTOR,FEMALE PIPE TO FLARE TUBE	48955	10 R6LO-S	RUN TEE,SWIVEL NUT,ORFS
48911	4-6 C5OLO-S	ELBOW,90°,STRAIGHT THREAD TO ORFS	48956	10-4 TRLO-BL-S	REDUCER,TUBE END TO SWIVEL,ORFS
48912	4-6 F5OLO-S	CONNECTOR,STRAIGHT THREAD TO ORFS	48957	10-6 TRLO-BL-S	REDUCER,TUBE END TO SWIVEL,ORFS
48913	4-6 F5OLO-SW/.030	CONNECTOR,STRAIGHT THREAD TO ORFS, W/.030 ORI	48958	10-12 F5OLO-S	CONNECTOR,STRAIGHT THREAD TO ORFS
48914	4-8 F5OLO-S	CONNECTOR,STRAIGHT THREAD TO ORFS	48959	12 C5OLO-S	ELBOW,90°,STRAIGHT THREAD TO ORFS
48915	6 C5OLO-S	ELBOW,90°,STRAIGHT THREAD TO ORFS	48960	12 F5OLO-S	CONNECTOR,STRAIGHT THREAD TO ORFS
48916	6 F5OLO-S	CONNECTOR,STRAIGHT THREAD TO ORFS	48961	12 R5OLO-S	RUN TEE,STRAIGHT THREAD
48917	6 FF5OLO-S	CONNECTOR,LONG,STRAIGHT THREAD TO ORFS	48962	12 S5OLO-S	BRANCH TEE,STRAIGHT THREAD TO ORFS
48918	6 R5OLO-S	RUN TEE,STRAIGHT THREAD	48963	12 V5OLO-S	ELBOW,45°,STRAIGHT THREAD TO ORFS
48919	6 S5OLO-S	BRANCH TEE,STRAIGHT THREAD TO ORFS	48964	12 R6LO-S	RUN TEE,SWIVEL NUT,ORFS
48920	6 V5OLO-S	ELBOW,45°,STRAIGHT THREAD TO ORFS	48965	12 CLO-S	ELBOW,90°,MALE PIPE TO ORFS
48921	6 FLO-S	CONNECTOR,MALE PIPE TO ORFS	48966	12 FLO-S	CONNECTOR,MALE PIPE TO ORFS
48922	6-6 FLO-S	CONNECTOR,MALE PIPE TO ORFS	48967	12 JLO-S	UNION TEE,ORFS
48923	6 P5ON-S	PLUG,STRAIGHT THREAD	48968	12 WLO-WLNL-S	UNION,BULKHEAD,ORFS
48925	6 WELO-S	UNION,90° BULKHEAD,ORFS	48969	12 WJLO-WLNL-S	RUN TEE, BULKHEAD,ORFS
48926	6-4 C5OLO-S	ELBOW,90°,STRAIGHT THREAD TO ORFS	48970	12 WELO-WLNL-S	UNION,90° BULKHEAD W/NUT,ORFS
48927	6-4 F5OLO-S	CONNECTOR,STRAIGHT THREAD TO ORFS			
48928	6-4 V5OLO-S	ELBOW,45°,STRAIGHT THREAD TO ORFS			
48929	6-8 C5OLO-S	ELBOW,90°,STRAIGHT THREAD TO ORFS			
48930	6-8 F5OLO-S	CONNECTOR,STRAIGHT THREAD TO ORFS			
48931	6-10 F5OLO-S	CONNECTOR,STRAIGHT THREAD TO ORFS			
48932	8 C5OLO-S	ELBOW,90°,STRAIGHT THREAD TO ORFS			
48933	8 F5OLO-S	CONNECTOR,STRAIGHT THREAD TO ORFS			
48934	8 FF5OLO-S	CONNECTOR,LONG,STRAIGHT THREAD TO ORFS			
48935	8 R5OLO-S	RUN TEE,STRAIGHT THREAD			
48936	8 S5OLO-S	BRANCH TEE,STRAIGHT THREAD TO ORFS			
48937	8 V5OLO-S	ELBOW,45°,STRAIGHT THREAD TO ORFS			

## Fitting Cross References (Continued)

Genie PN	Parker PN	Description	Genie PN	Parker PN	Description
48971	12 G5G5JG5-S	TEE,FEMALE STRAIGHT THREAD	49612	PKT02586	O-RING KIT (ORFS FITTINGS)
48972	12 XHL6-S	ADAPTER, 37° MALE TO SWIVEL ORFS	49613	PKT06276	PLUG AND CAP KIT-SERVICE,ORFS
48973	12-1/2 F5OG-S	ADAPTER,FEMALE PIPE TO STRAIGHT THREAD	49728	10143-12-12	HOSE END, MALE PIPE
48974	12-10 C5OLO-S	ELBOW,90°,STRAIGHT THREAD TO ORFS	49729	16-1 F5OG-S	ADAPTER,FEMALE PIPE TO STRAIGHT THREAD
48975	12-10 F5OLO-S	CONNECTOR,STRAIGHT THREAD TO ORFS	49814	12-8 FLO-S	CONNECTOR,MALE PIPE TO ORFS
48976	12-16 C5OLO-S	ELBOW,90°,STRAIGHT THREAD TO ORFS	49829	DT-500-MOMF-5	VALVE,CHECK
48977	12-16 F5OLO-S	CONNECTOR,STRAIGHT THREAD TO ORFS	49831	881-12	HOSE,3/4 INCH ID
48978	12-16 V5OLO-S	ELBOW,45°,STRAIGHT THREAD TO ORFS	49834	16 JLO-S	UNION TEE,ORFS
48980	12-16 FLO-S	CONNECTOR,MALE PIPE TO ORFS	49838	12-8 TRLO-BL-S	REDUCER,TUBE END TO SWIVEL,ORFS
48983	16 C5OLO-S	ELBOW,90°,STRAIGHT THREAD TO ORFS	49840	8 JLO-S	UNION TEE,ORFS
48984	16 F5OLO-S	CONNECTOR,STRAIGHT THREAD TO ORFS	49844	10-8 TRLO-BL-S	REDUCER,TUBE END TO SWIVEL,ORFS
48985	16 V5OLO-S	ELBOW,45°,STRAIGHT THREAD TO ORFS	49854	8 P5ON-S	PLUG,STRAIGHT THREAD
48986	16 FLO-S	CONNECTOR,MALE PIPE TO ORFS	49855	1JC43-16-12	HOSE END,FEMALE SWIVEL,SEAL LOK
48988	16 CD45-S	ELBOW,45°,MALE TO FEMALE PIPE	49859	4 P5ON-S	PLUG,STRAIGHT THREAD
48989	12 CD45-S	ELBOW,45°,MALE TO FEMALE PIPE	49861	4 FF5OLO-S	CONNECTOR,LONG,STRAIGHT THREAD TO ORFS
48990	8 CD45-S	ELBOW,45°,MALE TO FEMALE PIPE	49867	12-3/4 F5OG-S	ADAPTER,FEMALE PIPE TO STRAIGHT THREAD
48991	16-12 FLO-S	CONNECTOR,MALE PIPE TO ORFS	51152	6 R6X-S	RUN TEE,SWIVEL NUT,ORFS
48992	16-12 V5OLO-S	ELBOW,45°,STRAIGHT THREAD TO ORFS	51153	6-4 TRTX-S	REDUCER,TUBE END TO SWIVEL,ORFS
48993	XV501-12	BALL VALVE	51154	4-4 GTX	CONNECTOR,FEMALE PIPE TO FLARE TUBE
48994	XV501-16	BALL VALVE	51264	881-12	HOSE,3/4 INCH ID
48995	XV510P-12	BALL VALVE	51265	8 JLO-S	UNION TEE,ORFS
48996	XV510P-16	BALL VALVE	51508	6 BTX-S	NUT,FLARE TUBE
48997	PD341	DIAGNOSTIC NIPPLE, STRAIGHT THREAD	51580	12-8 TRLO-BL-S	TUBE END REDUCER,ORFS
48998	PD 361	DIAGNOSTIC NIPPLE, STRAIGHT THREAD	51628	6 R6X-S	RUN TEE,SWIVEL NUT,ORFS
48999	DT-500-MOMS-5	VALVE,CHECK	51735	3/8 HHP	PLUG,PIPE THREAD
49201	10 V5OLO-S	ELBOW,45°,STRAIGHT THREAD TO ORFS	51803	1J943-6-8	HOSE END,90° FEMALE SWIVEL,SEAL LOK
49202	1JC43-12-10	HOSE END,FEMALE SWIVEL,SEAL LOK	53023	125HBL-5-4	FITTING,HOSE BARB TO MALE PIPE
49203	10-8 V5OLO-S	ELBOW,45°,STRAIGHT THREAD TO ORFS	53497	PKT02585	O-RING KIT
49205	6 F5OHAO-S	UNION,STRAIGHT THREAD	53499	1JC71-16-16	HOSE END,FEMALE SWIVEL,SEAL LOK
49207	PD34BTL	DIAGNOSTIC NIPPLE,SEAL-LOK SWIVEL	53500	3-904	O-RING,STRAIGHT THREAD,-4
49209	8M18F870MX-S	CONNECTOR,METRIC,STRAIGHT THREAD TO FLARE TUBE	53501	3-906	O-RING,STRAIGHT THREAD,-6
49212	8 WGTX-WLN-S	CONNECTOR,BULKHEAD,FEMALE PIPE TO FLARE TUBE	53502	3-908	O-RING,STRAIGHT THREAD,-8
49213	30682-8-8	HOSE END,FEMALE SWIVEL,JIC	53503	3-910	O-RING,STRAIGHT THREAD,-10
49216	831-8	HOSE,1/2 INCH ID			
49217	33982-8-8	HOSE END,90° FEMALE SWIVEL,JIC			
49219	PS-B-35	SLEEVE,NYLON,2.19" ID			
49418	4-6 V5OLO-S	ELBOW,45°,STRAIGHT THREAD TO ORFS			
49511	DT370-MOMS-5	VALVE,CHECK			
49512	1 DD-S	ELBOW,90°,FEMALE PIPE			
49513	1 FF-S	NIPPLE,PIPE			
49514	10 HP5ON-S	PLUG,STRAIGHT THREAD			
49515	12-16 CLO-S	ELBOW,90°,MALE PIPE TO ORFS			
49517	6 HP5ON-S	PLUG,STRAIGHT THREAD			
49519	16-12 F5OLO-S	CONNECTOR,STRAIGHT THREAD TO ORFS			
49520	4 VTX-S	ELBOW,45°,MALE PIPE TO FLARE TUBE			
49530	16 C6LO-S	ELBOW,90°,SWIVEL NUT ORFS			

## Fitting Cross References (Continued)

Genie PN	Parker PN	Description	Genie PN	Parker PN	Description
53535	3-912	O-RING,STRAIGHT THREAD,-12	61083	24 F5OLO-S	CONNECTOR,STRAIGHT THREAD TO ORFS
53536	4-PNLO-S	PLUG,TUBE END,ORFS	61086	20 R5OLO-S	RUN TEE,STRAIGHT THREAD
53537	6 PNLO-S	PLUG,TUBE END,ORFS	61090	24-20 F5OLO-S	CONNECTOR,STRAIGHT THREAD TO ORFS
53538	8 PNLO-S	PLUG,TUBE END,ORFS	61091	1J943 24-24	HOSE END,90° FEMALE SWIVEL,SEAL LOK
53539	10 PNLO-S	PLUG,TUBE END,ORFS	61093	1J978-12-12	HOSE END,90° FEMALE SWIVEL,JIC
53540	12 PNLO-S	PLUG,TUBE END,ORFS	61095	1JS43-20-16	HOSE END,FEMALE SWIVEL,SEAL LOK
53946	129HB-5-4	FITTING,90° HOSE BARB TO MALE PIPE	61100	811-24	HOSE,11/2 INCH ID
53951	8-1/4F50G-S	ADAPTER,FEMALE PIPE TO STRAIGHT THREAD	61130	1JS43-24-24	HOSE END,FEMALE SWIVEL,SEAL LOK
53980	6 S6LO-S	BRANCH TEE,SWIVEL NUT TO ORFS	61131	1JS78 12-12	HOSE END,FEMALE SWIVEL,SEAL LOK
54132	4 C6LO-S	ELBOW,90°,SWIVEL NUT ORFS	61132	1J778-12-12	HOSE END,45° FEMALE SWIVEL,JIC
54135	11343-16-16	HOSE END,MALE SWIVEL,PIPE	61152	139HB-6-4	ELBOW,45°,BARB TO MALE PIPE
54283	8-10 C5OLO-S	ELBOW,90°,STRAIGHT THREAD TO ORFS	61251	BV-0750	BALL VALVE
54428	8M18C870MLO-S	ELBOW, 90° METRIC, STRAIGHT THREAD TO ORFS	61259	4 CC5OLO-S	ELBOW,90° LONG,STRAIGHT THREAD TO ORFS
54803	FS-F-16-10	SLEEVE,FIRE,-96" ID	61260	20-12 TRLO-BL	REDUCER,TUBE END TO SWIVEL,ORFS
54954	10143-2-4	HOSE END, MALE PIPE	61262	12 C6LO-S	ELBOW,90°,SWIVEL NUT ORFS
55190	3/8 HP-S	PLUG,PIPE THREAD	61263	20 F5OHAO-S	UNION,STRAIGHT THREAD
55448	8 HLO-S	UNION,ORFS	61264	6-10 C5OLO-S	ELBOW,90°,STRAIGHT THREAD TO ORFS
55839	6 F65OX-S	CONNECTOR,STRAIGHT THREAD TO 37° SWIVEL	61265	6 WNLO-WLNL-S	UNION,BULKHEAD 45°,ORFS
55968	10 C5OX-S	ELBOW,90°,STRAIGHT THREAD TO FLARE TUBE	61268	4 WNLO-WLNL-S	UNION,BULKHEAD 45°,ORFS
56003	6 CC5OLO-S	ELBOW,90° LONG,STRAIGHT THREAD TO ORFS	61269	4 WLO-WLNL-S	UNION,BULKHEAD,ORFS
56166	BV-0837	BALL VALVE,90°	61272	12 AOEL6	ELBOW,90°,STRAIGHT THREAD TO ORFS SWIVEL
56188	10143-8-6	HOSE END, MALE PIPE	61316	482TC-16	HOSE,1 INCH ID
56233	2-011	O-RING,ORFS,-4	61321	6 JLO-S	UNION TEE,ORFS
56234	2-012	O-RING,ORFS,-6	61327	782-12	HOSE,3/4 INCH ID
56235	2-014	O-RING,ORFS,-8	61328	881-24	HOSE,11/2 INCH ID
56236	2-016	O-RING,ORFS,-10	61336	11943-20-24	HOSE END,90° FLANGE HEAD
56237	2-018	O-RING,ORFS,-12	61345	12 WJLO-WLNL-S	RUN TEE, BULKHEAD,ORFS
56238	2-021	O-RING,ORFS,-16	61346	8 WNLO-WLNL-S 4	UNION,BULKHEAD 45°,ORFS
56352	6 WLNL-S	LOCKNUT,BULKHEAD	61569	33782-8-8	HOSE END,45° FEMALE SWIVEL,JIC
56353	3J782-12-12	HOSE END,45° FEMALE SWIVEL,SEAL LOK	61610	12 FF5OLO-S	CONNECTOR,LONG,STRAIGHT THREAD TO ORFS
56354	3J982-12-12	HOSE END,90° FEMALE SWIVEL,SEAL LOK	61742	1/8 X 1.5 FFF	NIPPLE,PIPE
56604	10-8 F5OLO-S	CONNECTOR,STRAIGHT THREAD TO ORFS	63426	8 PNTX-S	PLUG,FLARE TUBE
56639	3JC82-10-10	HOSE END,FEMALE SWIVEL,SEAL LOK			
56640	3J982-10-10	HOSE END,90° FEMALE SWIVEL,SEAL LOK			
56655	3JC82-8-10	HOSE END,FEMALE SWIVEL,SEAL LOK			
56676	10-8 C5OLO-S	ELBOW,90°,STRAIGHT THREAD TO ORFS			
56776	471TC-6	HOSE,3/8 INCH ID			
56777	471TC-8	HOSE,1/2 INCH ID			
56789	811-16	HOSE,1 INCH ID			
57884	3/8 FF	NIPPLE,PIPE			
59335	6 FNL-S	CAP, TUBE END			
59342	4 FNL-S	CAP, TUBE END			
59371	8 HP5ON-S	PLUG,STRAIGHT THREAD			
60653	BV-0751	BALL VALVE			
60806	125HB-3-4	FITTING,HOSE BARB TO MALE PIPE			
61064	5-1/4 F50G-S	ADAPTER,FEMALE PIPE TO STRAIGHT THREAD			
61079	4 WELO-WLNL-S	UNION,90° BULKHEAD W/NUT,ORFS			
61080	6 WLO-WLNL-S	UNION,BULKHEAD,ORFS			

## Fitting Cross References (Continued)

Genie PN	Parker PN	Description	Genie PN	Parker PN	Description
64271	4 WLO-WLNL-S	UNION,BULKHEAD,ORFS	75631	801-6	HOSE,3/8 INCH ID
64272	6 WLO-WLNL-S	UNION,BULKHEAD,ORFS	75654	20 F5OLO-S	CONNECTOR,STRAIGHT THREAD TO ORFS
65776	8 F65OL-S	CONNECTOR,STRAIGHT THREAD TO ORFS SWIVEL	75655	1J943-20-20	HOSE END,90° FEMALE SWIVEL,SEAL LOK
65880	6001012	O-RING KIT	75656	881-20	HOSE,1-1/4 INCH ID
66154	6 WTX-WLNS	UNION,BULKHEAD,FLARE TUBE	75971	8 F5OHAO-S	UNION,STRAIGHT THREAD
66155	6 WETX-S	UNION,BULKHEAD 90°,FLARE TUBE	77307	1JB43-8-8	HOSE END,BULKHEAD,SEAL LOK
66156	6 WLN-S	BULKHEAD LOCKNUT	77309	8 WLNL-S	BULKHEAD LOCKNUT
66389	6-8 F5OX-S	CONNECTOR,STRAIGHT THREAD TO FLARE TUBE	77379	8M18C87OMX-S	ELBOW,90° METRIC,STRAIGHT THREAD TO FLARE TUBE
66392	6 R5OX-S	RUN TEE,STRAIGHT THREAD	77703	3J982-8-8	HOSE END,90° FEMALE SWIVEL,SEAL LOK
66396	811-12	HOSE,3/4 INCH ID	77711	801-10	HOSE,5/8 INCH ID
66829	H3174PP	CLAMP,TUBE	77758	12 WNLO-WLNL-S	UNION,BULKHEAD 45°,ORFS
67217	4 KLO-S	UNION,CROSS,ORFS	78091	6 C6X-S	ELBOW,90°,SWIVEL NUT TO FLARE TUBE
67339	10-6 F5OX-S	CONNECTOR,STRAIGHT THREAD TO FLARE TUBE	78684	30582-8-8B	HOSE END,PUSH LOK,MALE
67357	13943-8-6	HOSE END,90° FEMALE SWIVEL,JIC	78852	549-2	HOSE,1/8 INCH ID
67358	10 HP5ON-S	PLUG,STRAIGHT THREAD	78855	10657-4-2	HOSE END,FEMALE SWIVEL,JIC
67371	12 S6LO-S	BRANCH TEE,SWIVEL NUT TO ORFS	79138	PS-B-37	SLEEVE,NYLON,2.38" ID
67498	4 FNL-S	CAP, TUBE END	79476	1JS43-6-8	HOSE END,FEMALE SWIVEL,SEAL LOK
67906	DC-370-F0F0-5	VALVE,CHECK	79847	12-3/4 A0EG-S	ELBOW,90°,STRAIGHT THREAD TO FEMALE PIPE
69316	8 FLO-S	CONNECTOR,MALE PIPE TO ORFS	80044	8 CLO-S	ELBOW,90°,MALE PIPE TO ORFS
69333	H3174PP	CLAMP,HYDRAULIC HOSE	80502	8 F5OX-S	CONNECTOR,STRAIGHT THREAD TO FLARE TUBE
69503	4 F65OX-S	CONNECTOR,STRAIGHT THREAD TO 37° SWIVEL	80503	8 C5OX-S	ELBOW,90°,STRAIGHT THREAD TO FLARE TUBE
69775	8 FNL-S	CAP, TUBE END	81010	AS-B-27	SLEEVE,NYLON,1.63" ID
71038	1/4X1/4F3HG-S	ADAPTER,CONVERSION	83052	821-6	HOSE,3/8 INCH ID
71196	12-8 F5OLO-S	CONNECTOR,STRAIGHT THREAD TO ORFS	83053	821-8	HOSE,1/2 INCH ID
71383	1/4 CD45-S	ELBOW,45°,MALE TO FEMALE PIPE	83054	821-12	HOSE,3/4 INCH ID
72270	12FNL-S	CAP, TUBE END	83055	30682-6-6	HOSE END,FEMALE SWIVEL,JIC
73436	60C-4	SLEEVE,COMPRESSION	83056	30682-12-12	HOSE END,FEMALE SWIVEL,JIC
73437	61C-4	NUT,COMPRESSION	83057	33782-6-6	HOSE END,45° FEMALE SWIVEL,JIC
73438	33482-4-4B	HOSE END,PUSH LOK,MALE	83058	33982-6-6	HOSE END,90° FEMALE SWIVEL,JIC
73767	1CD-S	ELBOW,90°,MALE TO FEMALE PIPE	83060	33982-12-12	HOSE END,90° FEMALE SWIVEL,JIC
73768	20-16-F5OG5-S	ADAPTER,FEMALE PIPE TO STRAIGHT THREAD	83063	13743-4-4	HOSE END,45° FEMALE SWIVEL,JIC
73769	16-20 F5OLO-S	CONNECTOR,STRAIGHT THREAD TO ORFS			
74660	6-8 F42EDMLO-S	CONNECTOR,MALE BSPP TO ORFS			
74661	8-8 F42EDMLO-S	CONNECTOR,MALE BSPP TO ORFS			
75007	4 FLO-S	CONNECTOR,MALE PIPE TO ORFS			
75008	1/8 HP-S	PLUG,PIPE THREAD			
75014	1/2 HP-S	PLUG,PIPE THREAD			
75042	8 WELO-WLNL-S	UNION,90° BULKHEAD W/NUT,ORFS			
75043	3/4 FF-S	NIPPLE,PIPE			
75254	24 F5OHAO-S	UNION,STRAIGHT THREAD			
75255	12 F5OHAO-S	UNION,STRAIGHT THREAD			
75256	XV506P-24	BALL VALVE			
75574	4 WLNL-S	BULKHEAD LOCKNUT			
75612	8 WJLO-WLNL-S	RUN TEE, BULKHEAD,ORFS			
75613	12-8 F5OG5-S	ADAPTER,FEMALE PIPE TO STRAIGHT THREAD			
75614	8 CC5OLO-S	ELBOW,90° LONG,STRAIGHT THREAD TO ORFS			
75628	1JB43-4-4	HOSE END,BULKHEAD,SEAL LOK			

## Fitting Cross References (Continued)

Genie PN	Parker PN	Description	Genie PN	Parker PN	Description
83064	13743-8-8	HOSE END,45° FEMALE SWIVEL,JIC	89449	6 WJLO-WLNL-S	RUN TEE, BULKHEAD,ORFS
83065	13743-12-12	HOSE END,45° FEMALE SWIVEL,JIC	89489	4 WJMLO-S	BRANCH TEE,BULKHEAD,ORFS
83066	13943-8-8	HOSE END,90° FEMALE SWIVEL,JIC	89551	1JB43-6-6	HOSE END,BULKHEAD,SEAL LOK
83067	14143-6-6	HOSE END,90° FEMALE SWIVEL,JIC	89552	1JB43-8-8	HOSE END,BULKHEAD,SEAL LOK
83068	14143-8-8	HOSE END,90° FEMALE SWIVEL,JIC	89593	20 C5OLO-S	ELBOW,90°,STRAIGHT THREAD TO ORFS
83069	14143-12-12	HOSE END,90° FEMALE SWIVEL,JIC	94161	8-8 CLO-S	ELBOW,90°,MALE PIPE TO ORFS
83070	772-8	HOSE,1/2 INCH ID	94358	351TC-12	HOSE,3/4 INCH ID
83071	10671-8-8	HOSE END,FEMALE SWIVEL,JIC	94418	20 FLO-S	CONNECTOR,MALE PIPE TO ORFS
83072	10671-12-12	HOSE END,FEMALE SWIVEL,JIC	96358	12 TX-S	SLEEVE,FLARE TUBE
83073	13771-8-8	HOSE END,45° FEMALE SWIVEL,JIC	96359	12 BTX-S	NUT,FLARE TUBE
83074	13771-12-12	HOSE END,45° FEMALE SWIVEL,JIC	96397	8 F5OX-S	CONNECTOR,STRAIGHT THREAD TO FLARE TUBE
83075	13971-8-8	HOSE END,90° FEMALE SWIVEL,JIC	96398	12-8 F5OX-S	CONNECTOR,STRAIGHT THREAD TO FLARE TUBE
83076	13971-12-12	HOSE END,90° FEMALE SWIVEL,JIC	96402	10343-6-6	HOSE END,MALE,JIC
83077	14171-8-8	HOSE END,90° FEMALE SWIVEL,JIC	96407	30382-6-6B	HOSE END,MALE,JIC
83078	14171-12-12	HOSE END,90° FEMALE SWIVEL,JIC			
83080	13943-16-16	HOSE END,90° FEMALE SWIVEL,JIC			
83103	10671-16-12	HOSE END,FEMALE SWIVEL,JIC			
83104	10671-10-12	HOSE END,FEMALE SWIVEL,JIC			
83112	1JC71-8-8	HOSE END,FEMALE SWIVEL,SEAL LOK			
83113	1JS71-16-12	HOSE END,FEMALE SWIVEL,SEAL LOK			
83114	1JS71-10-12	HOSE END,FEMALE SWIVEL,SEAL LOK			
83115	1J971-8-8	HOSE END,90° FEMALE SWIVEL,SEAL LOK			
83116	1J171-8-8	HOSE END,90° FEMALE SWIVEL,SEAL LOK			
83117	1J771-8-8	HOSE END,45° FEMALE SWIVEL,SEAL LOK			
83127	1J543-6-8	HOSE END,90° FEMALE SWIVEL,JIC			
83128	1JC43-6-8	HOSE END,FEMALE SWIVEL,SEAL LOK			
87033	12-6 TRLO-S	REDUCER,TUBE END TO SWIVEL,ORFS			
87034	3J782-8-8	HOSE END,45° FEMALE SWIVEL,SEAL LOK			
87172	12 HP5ON-S	PLUG,STRAIGHT THREAD			
87185	8 WNLO-WLNL-S	UNION,BULKHEAD 45°,ORFS			
87246	4 C6X-S	ELBOW,90°,SWIVEL NUT TO FLARE TUBE			
87679	6 LHP-S	FLANGE SEAL FITTING, MALE			
87681	6PLS N0702	BONDED SEAL			
88100	SR88100	ADAPTER,OIL DRAIN,GM 3.0L			
88311	1JS43-20-20	HOSE END,FEMALE SWIVEL,SEAL LOK			
88353	20 V5OLO-S	ELBOW,45°,STRAIGHT THREAD TO ORFS			
88474	10081-20	Crimp Shell, 1.25"			
88475	1988-20-24	HOSE END,90° FLANGE HEAD			
88476	JS88-24-24	HOSE END,FEMALE SWIVEL,SEAL LOK			
88477	1JC88-20-20	HOSE END,FEMALE SWIVEL,SEAL LOK			
88478	811-20	HOSE,11/4 INCH ID			
88936	20-16 F5OLO-S	CONNECTOR,STRAIGHT THREAD TO ORFS			
88937	20-16 FLO-S	CONNECTOR,MALE PIPE TO ORFS			
88938	1JC88-16-16	HOSE END,FEMALE SWIVEL,SEAL LOK			
88939	1J988-16-16	HOSE END,90° FEMALE SWIVEL,ORFS			
88940	811-16	HOSE,1 INCH ID			
88944	1J988-20-20	HOSE END,90° FEMALE SWIVEL,ORFS			
89403	16 VLO-S	ELBOW,45°,MALE PIPE TO ORFS			

---

**Genie Scandinavia****Phone** +46 31 575100**Fax** +46 31 579020

---

**Genie France****Phone** +33 (0)2 37 26 09 99**Fax** +33 (0)2 37 26 09 98

---

**Genie Iberica****Phone** +34 93 579 5042**Fax** +34 93 579 5059

---

**Genie Germany****Phone** +49 (0)4202 88520**Fax** +49 (0)4202 8852-20

---

**Genie U.K.****Phone** +44 (0)1476 584333**Fax** +44 (0)1476 584334

---

**Genie Mexico City****Phone** +52 55 5666 5242**Fax** +52 55 5666 3241

---

**Genie North America****Phone** 425.881.1800**Toll Free** USA and Canada

800.536.1800

**Fax** 425.883.3475

---

**Genie Australia Pty Ltd.****Phone** +61 7 3375 1660**Fax** +61 7 3375 1002

---

**Genie China****Phone** +86 21 53852570**Fax** +86 21 53852569

---

**Genie Malaysia****Phone** +65 98 480 775**Fax** +65 67 533 544

---

**Genie Japan****Phone** +81 3 3453 6082**Fax** +81 3 3453 6083

---

**Genie Korea****Phone** +82 25 587 267**Fax** +82 25 583 910

---

**Genie Brasil****Phone** +55 11 41 665 755**Fax** +55 11 41 665 754

---

**Genie Holland****Phone** +31 183 581 102**Fax** +31 183 581 566

Distributed By:

# Parts Manual

GS-2046

GS-2646

to SN 59999

Part No.  
48338

Rev G4

**Genie**  
A TEREK BRAND