

Tennessee Comprehensive Assessment Program TCAP

Geometry Practice Test



Please PRINT all information in the box.

Student Name: _____

Teacher Name: _____

School: _____

District: _____

All practice test items represent the appropriate grade level/content standards—however, the practice test may contain item types that no longer appear on the operational assessment.



TNReady Math Reference Sheet—High School

1 inch = 2.54 centimeters

1 mile = 5,280 feet

1 mile = 1,760 yards

1 mile = 1.609 kilometers

1 kilometer = 0.62 mile

1 meter = 39.37 inches

1 pound = 16 ounces

1 pound = 0.454 kilograms

1 kilogram = 2.2 pounds

1 ton = 2,000 pounds

1 cup = 8 fluid ounces

1 pint = 2 cups

1 quart = 2 pints

1 gallon = 4 quarts

1 gallon = 3.785 liters

1 liter = 0.264 gallons

1 liter = 1,000 cubic centimeters

Exponential Growth: $y = a(1 + r)^t$

Exponential Decay: $y = a(1 - r)^t$

Compound Interest: $A = P\left(1 + \frac{r}{n}\right)^{nt}$

Continually Compounding Interest:
 $A = Pe^{rt}$

Arithmetic Sequence: $a_n = a_1 + (n - 1)d$

Geometric Sequence: $a_n = a_1(r)^{n-1}$

Finite Geometric Series: $S_n = \frac{a_1(1 - r^n)}{1 - r}$

Degrees: 1 degree = $\frac{\pi}{180}$ radians

Radians: 1 radian = $\frac{180}{\pi}$ degrees

**No test material
on this page**

Directions

This test has Subpart 1, Subpart 2, and Subpart 3. Each subpart contains various types of assessment questions.

You MAY NOT use a calculator in Subpart 1 of this test.

Sample: Written response (fill in the blank)

In $\triangle QRS$, $m\angle Q = 23^\circ$ and $m\angle R = 66^\circ$.

What is the measure, in degrees, of $m\angle S$?

Enter your answer in the space provided.



Do not go on to the next page until told to do so.



- 1 Triangle RST and triangle $R'S'T'$ are shown.

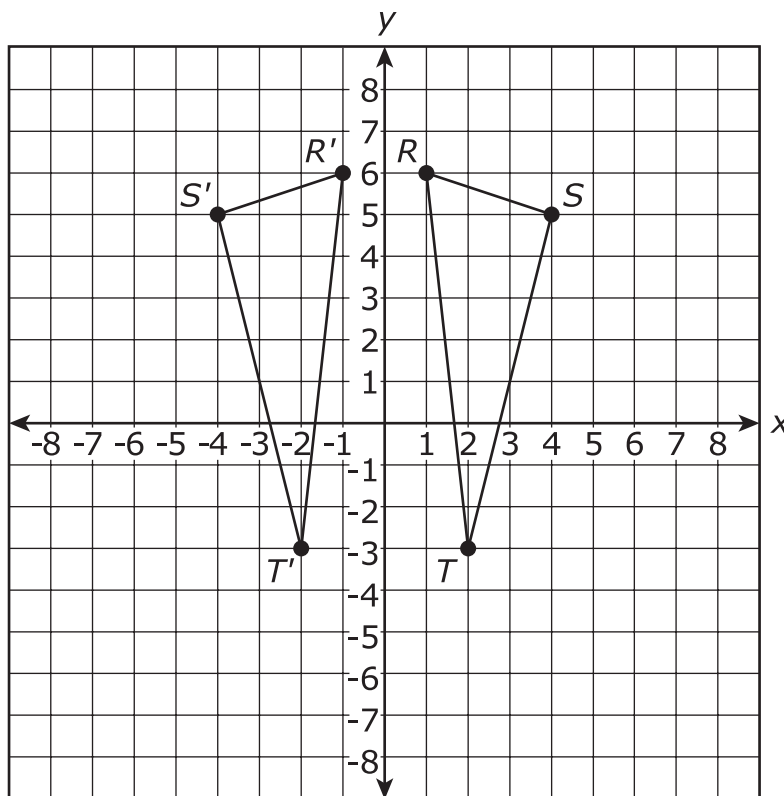

For which transformation would triangle RST have image $R'S'T'$?

- A. a 180° rotation
- B. a translation left 8 units
- C. a reflection over the y -axis
- D. a reflection over the x -axis



- 2 Isosceles trapezoid $RSTU$, with K as midpoint of \overline{RS} , L as midpoint of \overline{ST} , M as midpoint of \overline{TU} , and N as midpoint of \overline{RU} , is shown. Point P is the intersection of \overline{KM} and \overline{NL} .

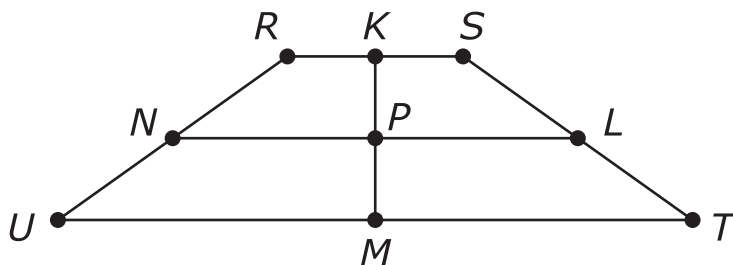

Which transformation carries the trapezoid onto itself?

- M. a 90° rotation clockwise about P
- P. a 180° rotation clockwise about P
- R. a reflection over \overline{KM}
- S. a reflection over \overline{NL}



- 3** Shanika is making a decorative tablecloth for her small circular table. The table has a radius of 40 centimeters and a height of 60 centimeters. She wants the tablecloth to hang an even 10 centimeters above the ground.

Which design would give Shanika what she wants?

- A.** a circular piece of cloth with a radius of 90 cm
- B.** a circular piece of cloth with a radius of 100 cm
- C.** a circular piece of cloth with a radius of 110 cm
- D.** a circular piece of cloth with a radius of 130 cm

- 4** The three line segments dividing the two sides of the triangle shown are parallel to the base of the triangle.

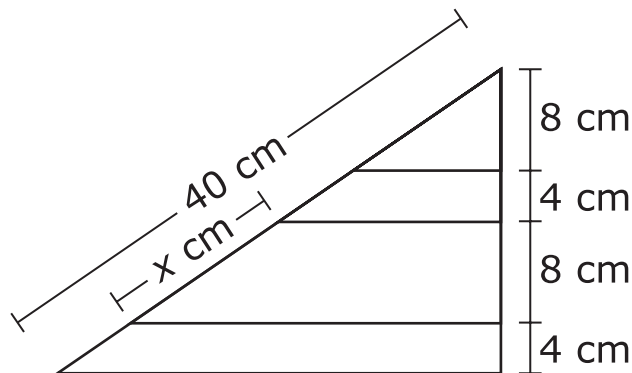

Which proportion can be used to find the value of x ?

- M.** $\frac{1}{4} = \frac{x}{8}$
- P.** $\frac{1}{4} = \frac{8}{x}$
- R.** $\frac{24}{40} = \frac{x}{8}$
- S.** $\frac{24}{40} = \frac{8}{x}$



- 5 Determine which statement is true in regard to $\triangle ABC$ and $\triangle LMN$.

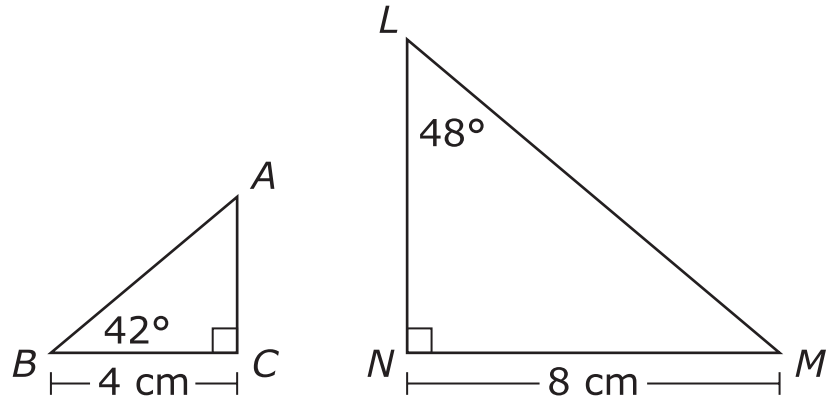

- A. $\triangle ABC \sim \triangle LMN$ by AA criterion.
- B. $\triangle ABC \sim \triangle LMN$ by SAS criterion.
- C. $\triangle ABC \sim \triangle LMN$ by SSS criterion.
- D. $\triangle ABC$ and $\triangle LMN$ are not similar.

- 6 The triangles QTP and SPT are shown. Ray MR is the perpendicular bisector of line segment PT and intersects line segment PT at point M .

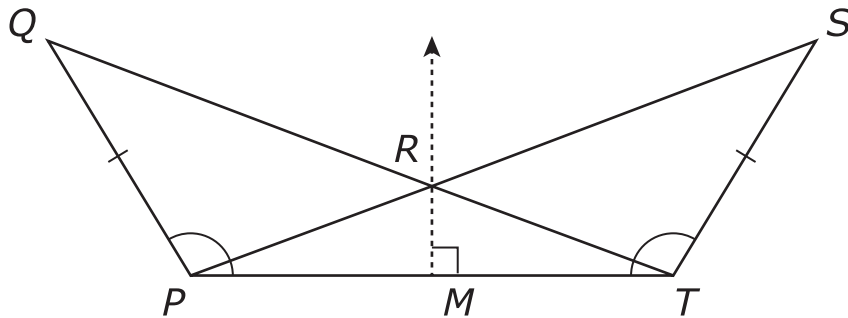

Which transformation would indicate that $\triangle QTP \cong \triangle SPT$?

- M. horizontal translation the length of \overline{PR}
- P. horizontal translation the length of \overline{PT}
- R. reflection over \overline{QT}
- S. reflection over \overrightarrow{MR}



- 7 A circle is represented by the equation shown.

$$(x - 1)^2 + (y - 2)^2 = 4$$

Which graph best represents this circle?

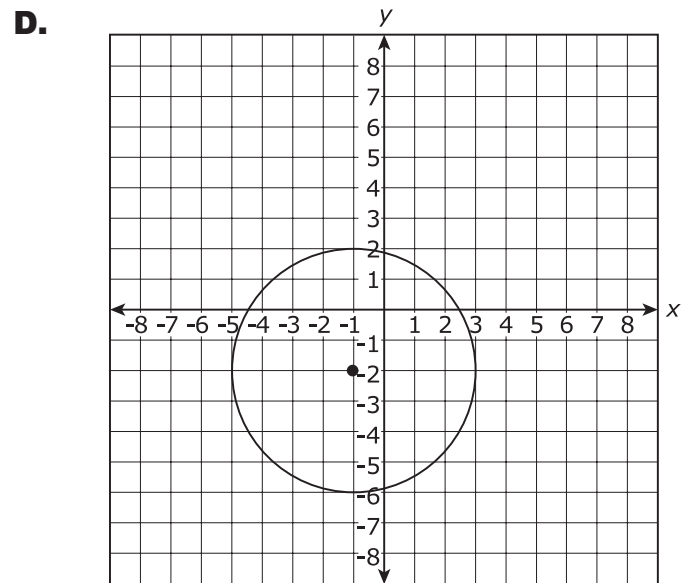
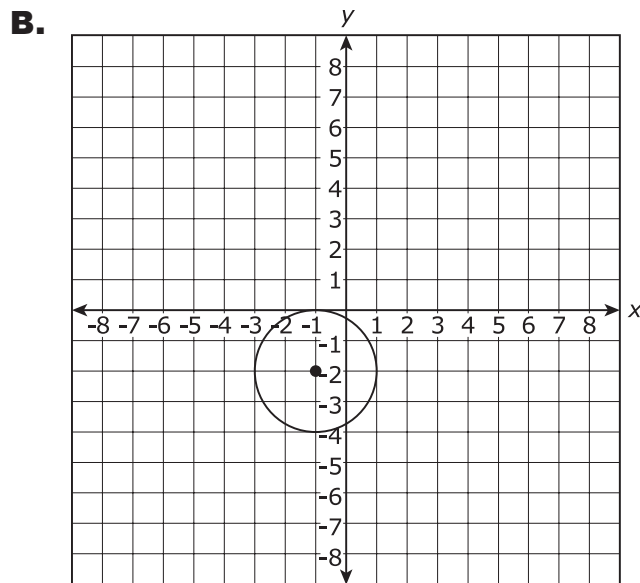
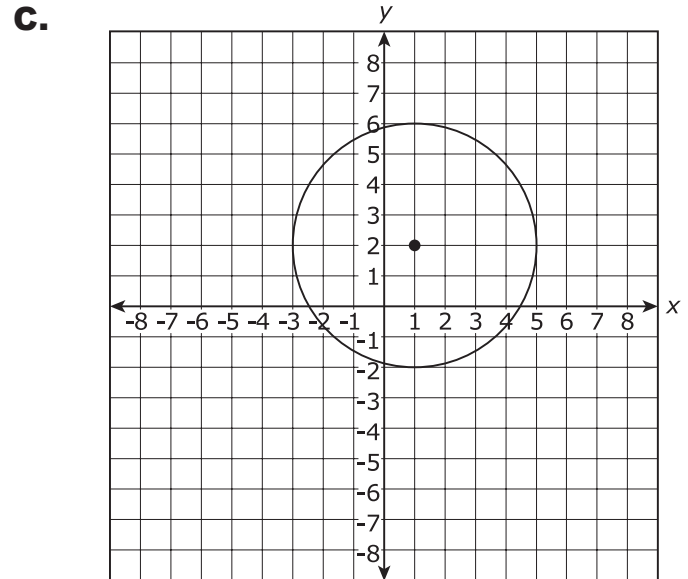
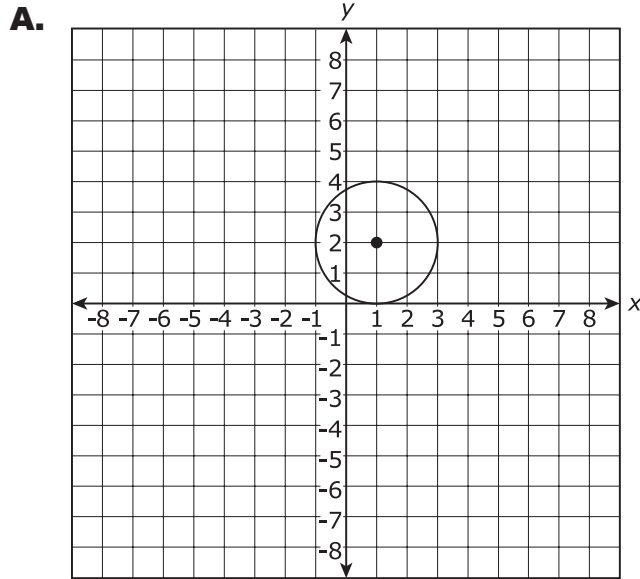

**This is the end of Subpart 1 of the Geometry Test.
Do not go on to the next page until told to do so.**

**No test material
on this page**

**No test material
on this page**

Directions

Subpart 2 of this test contains various types of assessment questions.

You MAY use a calculator in Subpart 2 of this test.



Do not go on to the next page until told to do so.



8 The measurements of the circumferences and radii of circles with different areas are recorded and analyzed. Which statement justifies why this information can be used to approximate the value of pi?

- A. The area of a circle varies inversely as the radius.
- B. The circumference of a circle varies inversely as the radius.
- C. The circumference of a circle varies directly as the radius.
- D. The area of a circle varies directly as the radius.

9 $\triangle RSV \sim \triangle UST$

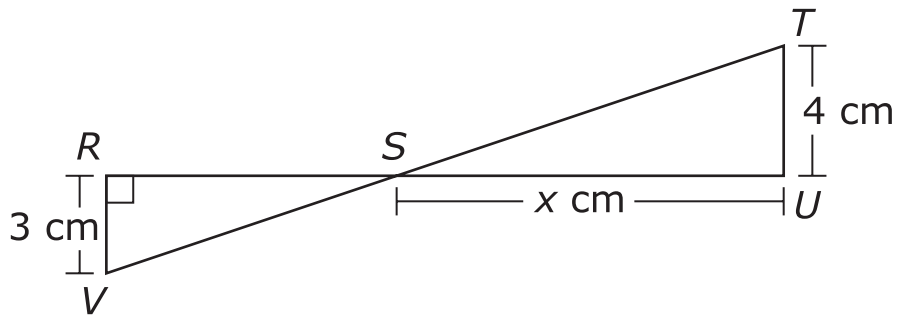

Select the **two** statements that must be true.

- M. $\triangle STU$ is a right triangle.
- P. \overline{RS} is $\frac{4}{3}x$ cm in length.
- R. $\angle VRS \cong \angle STU$
- S. $\overline{SV} \cong \overline{ST}$
- T. $m\angle RVS + m\angle UST = 90^\circ$



- 10** In the figure, \overrightarrow{PS} is tangent to circle O at point S . Arc QR measures 110° and arc RS measures 150° .

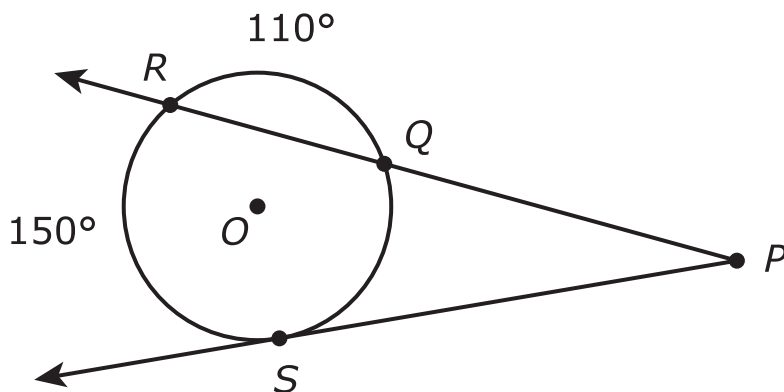

What is the measure, in degrees, of $\angle QPS$?

Enter your answer in the space provided.



- 11 The windshield wiper of a car rotates through an angle of measure $\frac{5\pi}{6}$ radians, as shown.

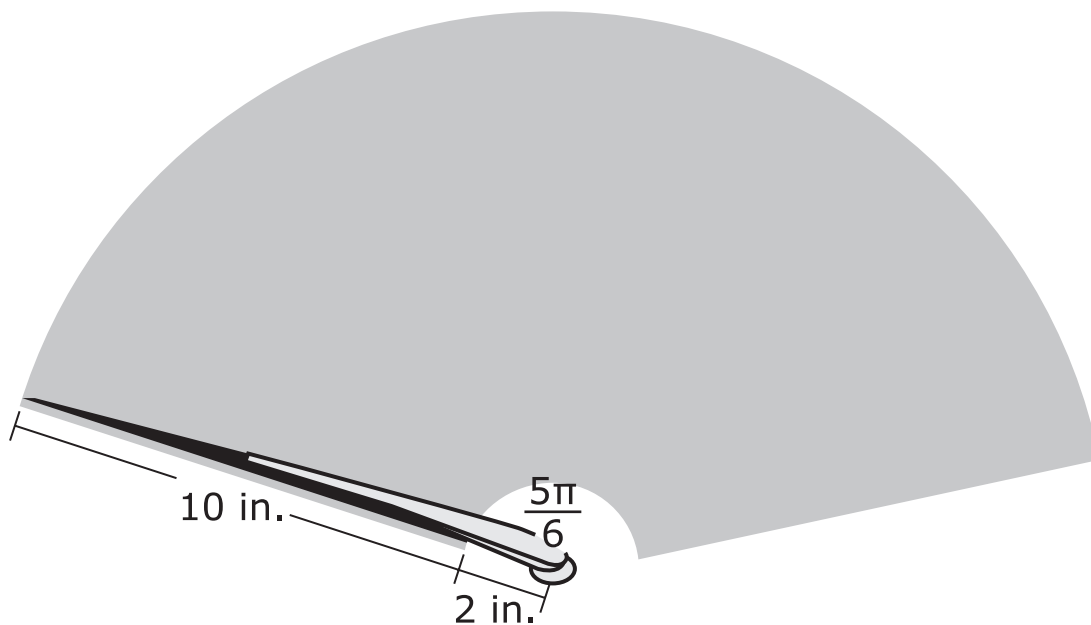

The shaded section of the diagram represents the area cleared by the 10-inch blade of the windshield wiper as it moves from one side to the other. Approximately what is the area cleared by the blade of the windshield wiper?

- A. 125 in.²
- B. 183 in.²
- C. 367 in.²
- D. 790 in.²



- 12 In the figure shown, $\triangle RST \sim \triangle UVW$.

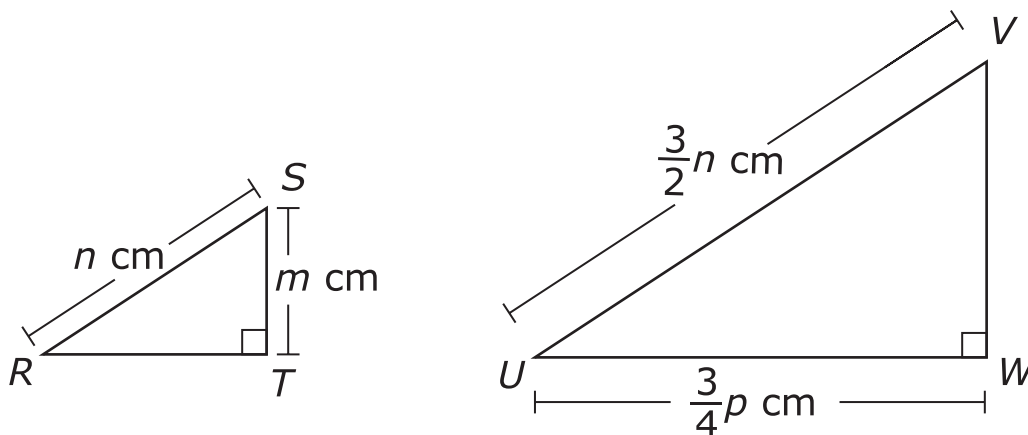

Write an expression in terms of m and p that represents $\tan(R)$.

Enter your answer in the space provided.



- 13 The two chords shown in the circle intercept the given arcs.

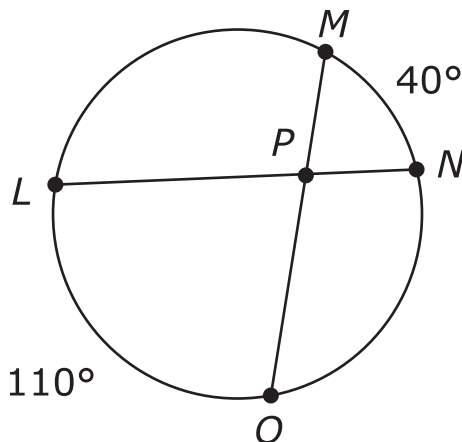

What is the measure of $\angle MPN$?

- M. 70°
 - P. 75°
 - R. 115°
 - S. 150°
- 14 Andrea wants to build a rectangular play area for her dog using 36 feet of fencing. She wants the play area to be as **large** as possible.

What is the width, in feet, of the play area Andrea should build.

Enter your answer in the space provided.



- 15** Parallelogram $RSTU$ is shown. The perimeter of parallelogram $RSTU$ is 50 centimeters.

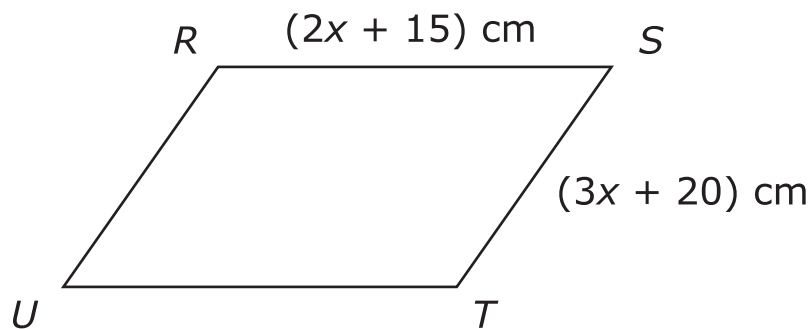

What is the value of x ?

- A.** -5
- B.** -2
- C.** 3
- D.** 12



- 16** Chris is looking up at the top of a tree. He is standing 20 feet from the tree, and his line of sight is 35° from horizontal. His eyes are 5 feet above the ground.

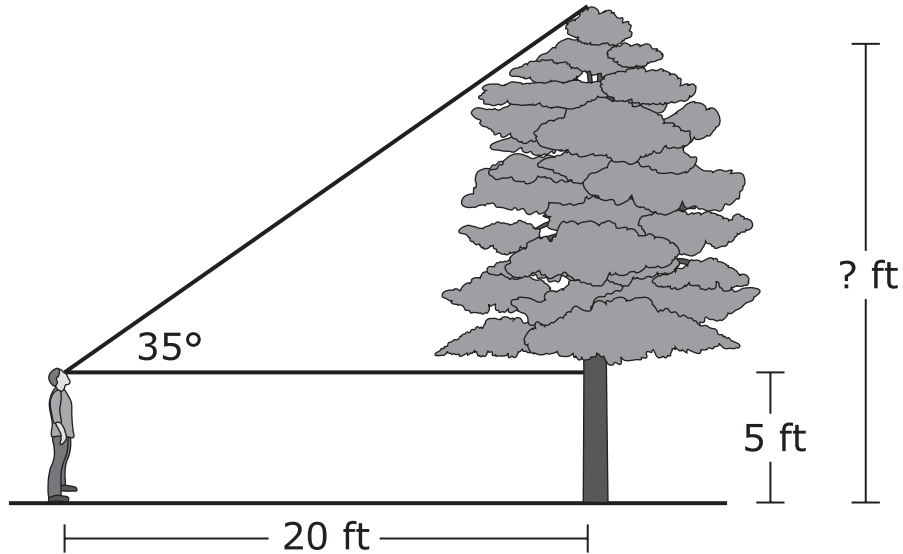

To the nearest foot, how tall is the tree?

Enter your answer in the space provided.



- 17** A right triangle has leg lengths of 3 centimeters and 4 centimeters. What is $\cos \theta$ where θ is the smallest angle of the triangle?

Enter your answer in the space provided.

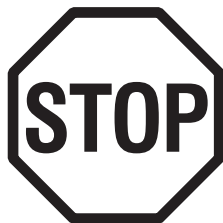

**This is the end of Subpart 2 of the Geometry Test.
Do not go on to the next page until told to do so.**

**No test material
on this page**

Directions

Subpart 3 of this test contains various types of assessment questions.

You MAY use a calculator in Subpart 3 of this test.

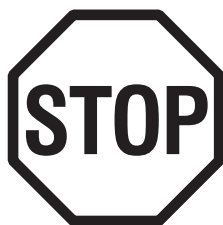

Do not go on to the next page until told to do so.



- 18** A water sprinkler covers a circular area with a diameter of 20 feet. If it is set to cover only an arc measuring 120 degrees, which is closest to the area, in square feet, the sprinkler will cover?
- A.** 10
B. 21
C. 105
D. 419
- 19** The dimensions of a rectangular prism are 26 inches by 10 inches by 8 inches. What is the surface area, in square inches, of the prism?
- M.** 548
P. 936
R. 1,096
S. 2,080



- 20 Mr. Miller is trying to determine the width of his pond. He makes the measurements shown.

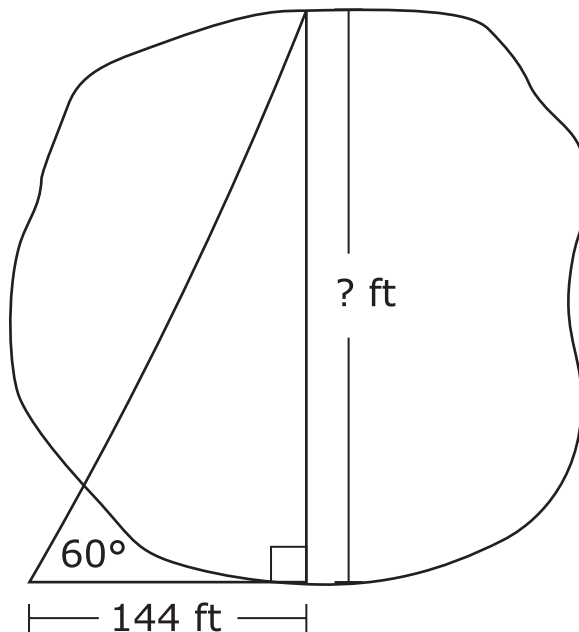

To the nearest foot, what is the width of the pond?

Enter your answer in the space provided.



- 21 The illustration shown represents the intersections of three roads: Highway 35, State Route 17, and Interstate 16. The region bounded by the three roads is represented by $\triangle ABC$. Each unit in the grid represents 1 mile.

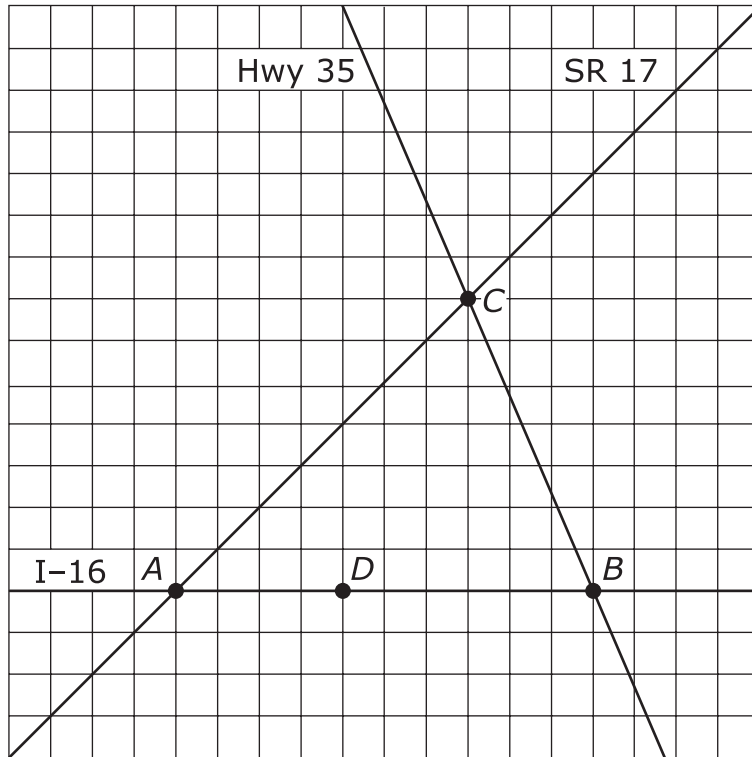

Which statements about $\triangle ABC$ are true? Select the **three** that apply.

- A. $BC = \sqrt{58}$
- B. $\overline{AB} \cong \overline{AC}$
- C. $\tan(m\angle BAC) = 1$
- D. $m\angle ABC + m\angle ACB = 2(m\angle BAC)$
- E. $\frac{\sin(m\angle BAC)}{BC} = \frac{\sin(m\angle ABC)}{AC}$



- 22 Quadrilateral $LMNO$ has coordinates $L(5, 6)$, $M(9, 8)$, $N(11, 12)$, and $O(7, 10)$.

How can quadrilateral $LMNO$ be classified?

- M. square
- P. rhombus but not a square
- R. rectangle but not a square
- S. parallelogram but neither a rhombus nor a rectangle

- 23 A line segment has end points $R(-2, -2)$ and $S(4, 1)$. What is the x -coordinate of the point that is $\frac{2}{3}$ of the way from R to S on this line segment?

Enter your answer in the space provided.

- 24 $\triangle RST \sim \triangle UVW$. The dilation that maps $\triangle RST$ to $\triangle UVW$ has a dilation factor of $\frac{2}{3}$.

The measure of angle R is 20° , and the measure of angle S is 100° .

What is the measure, in degrees, of angle W ?

Enter your answer in the space provided.

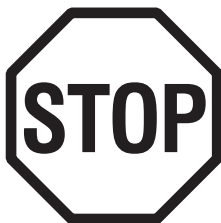

This is the end of the test.

Name: _____

Subpart 1 Practice Test Questions

- 1. Ⓐ Ⓑ Ⓒ Ⓓ
- 2. Ⓜ Ⓟ Ⓡ Ⓢ
- 3. Ⓐ Ⓑ Ⓒ Ⓓ
- 4. Ⓜ Ⓟ Ⓡ Ⓢ
- 5. Ⓐ Ⓑ Ⓒ Ⓓ
- 6. Ⓜ Ⓟ Ⓡ Ⓢ
- 7. Ⓐ Ⓑ Ⓒ Ⓓ

Subpart 2 Practice Test Questions

8. Ⓐ Ⓑ Ⓒ Ⓓ

9. Ⓜ Ⓟ Ⓡ Ⓢ Ⓣ

10.

11. Ⓐ Ⓑ Ⓒ Ⓓ

12.

13. Ⓜ Ⓟ Ⓡ Ⓢ

14.

15. Ⓐ Ⓑ Ⓒ Ⓓ

16.

17.

Subpart 3 Practice Test Questions

18. (A) (B) (C) (D)

19. (M) (P) (R) (S)

20.

21. (A) (B) (C) (D) (E) (Select **three**)

22. (M) (P) (R) (S)

23.

24.



**No test material
on this page**

Subpart 1 Practice Test Questions

- 1. A B C D
- 2. M P R S
- 3. A B C D
- 4. M P R S
- 5. A B C D
- 6. M P R S
- 7. A B C D

Subpart 2 Practice Test Questions

8. A B C D9. P Q R S T10. 11. A B C D12. 13. M P Q R14. 15. A B C D16. 17.

Subpart 3 Practice Test Questions

18. A B C D

19. M P R S

20.

21. A B C D E (Select **three**)

22. M P R S

23.

24.

**No test material
on this page**



TNReady Practice Test Standards Alignment and Key - Geometry

Subpart 1	Key	Standard
1	C	G.CO.A.5
2	R	G.CO.A.3
3	A	G.MG.A.1
4	S	G.SRT.B.4
5	A	G.SRT.A.3
6	S	G.CO.B.6
7	A	G.GPE.A.1
Subpart 2		
8	C	G.GMD.A.1
9	M, T	G.SRT.B.5
10	25	G.C.A.2
11	B	G.C.B.4
12	$\frac{2m}{p}$	G.SRT.C.6
13	P	G.C.A.2
14	9	G.MG.A.2
15	B	G.CO.C.11
16	19	G.SRT.C.8a
17	0.8	G.SRT.C.6
Subpart 3		
18	C	G.C.B.4
19	R	G.GMD.A.2
20	249	G.SRT.C.8a
21	A, C, E	G.SRT.C.8
22	P	G.GPE.B.5
23	2	G.GPE.B.4
24	60	G.SRT.A.2

**No test material
on this page**

**No test material
on this page**

**No test material
on this page**

Tennessee Comprehensive
Assessment Program TCAP
Geometry
Practice Test

