

www.summerreadingclub.org.au

Summer Reading Club



Primary Activity Book



Australian Library and Information Association



State Library of Queensland



Queensland Government



GET LOST IN A GOOD BOOK THIS SUMMER!

Welcome Summer Reading Club Adventurers to the SRC Primary Activity Booklet—created especially for you. Completing the activities in this booklet is just one way to participate in the 2015 Summer Reading Club Lost Worlds program this year.

There is lots more to do online and at your public library. So go on, don't get lost or left behind — join in the SRC fun at your library or jump online to register!

Get Lost at Your Library

Discover underwater worlds, alternate universes and more by participating in the Summer Reading Club at your local public library.

- **Borrow reading material**
Explore lost places, hidden realms and mythical creatures as you dive into science fiction, historical fiction and fantasy fiction.
- **Explore your library collections**
Ask your librarian for extra reading recommendations or help to find information about real Lost Worlds or Lost Places like the Bermuda Triangle or the Lost City of Atlantis.
- **Participate**
Get involved in the SRC activities at your library to receive SRC themed incentives and prizes.*

* Note: Programs, activities and incentives delivered locally are provided at the library's discretion. Check with your librarian or library's **What's On** to find out what is on offer for you at your library this summer!

Get Lost Online

Cross off the activities you complete online at www.summerreadingclub.org.au/theclub

Register your participation	Log your reading	Post a book rave
Meet newly published authors	Enter online draws	Post artwork to the SRC Gallery
Follow Celebrity Author blogs	Share your feedback	

Primary Great Reads

The following titles are suggested books to read this summer. How many can you find at your library?

- Robert Irwin: Dinosaur Hunter Collection*, Robert Irwin & Jack Wells
- The Puzzle Ring*, Kate Forsyth
- The Deep: Here Be Dragons*, Tom Taylor
- Dinosaur Knights*, Michael Gerard Bauer
- A Wrinkle in Time*, Madeleine L'Engle
- Lost World Circus Series*, Justin D'Ath
- Pathfinder*, Angie Sage
- Magisterium: The Iron Trial*, Holly Black & Cassandra Clare
- The Big Big Big Book of Tashi*, Anna & Barbara Fienberg
- The Spiderwick Chronicles*, Tony DiTerlizzi & Holly Black
- The Lion, The Witch and the Wardrobe*, C.S. Lewis
- Kumiko and the Dragon*, Briony Stewart
- Send Simon Savage*, Stephen Measday
- Bumper Blobheads*, Paul Stewart & Chris Riddell
- The Enchanted Wood*, Enid Blyton
- The Last Thirteen: Book 1*, James Phelan
- A Really Short History of Nearly Everything*, Bill Bryson
- Harry Potter and the Philosopher's Stone*, J.K. Rowling

Add your own

- _____
- _____
- _____
- _____

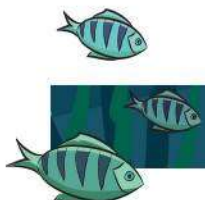

WHAT ARE YOU READING?

Draw the cover OR create your own artwork for the Lost Worlds inspired book you are reading. Remember to include the title and author of the book on your cover.

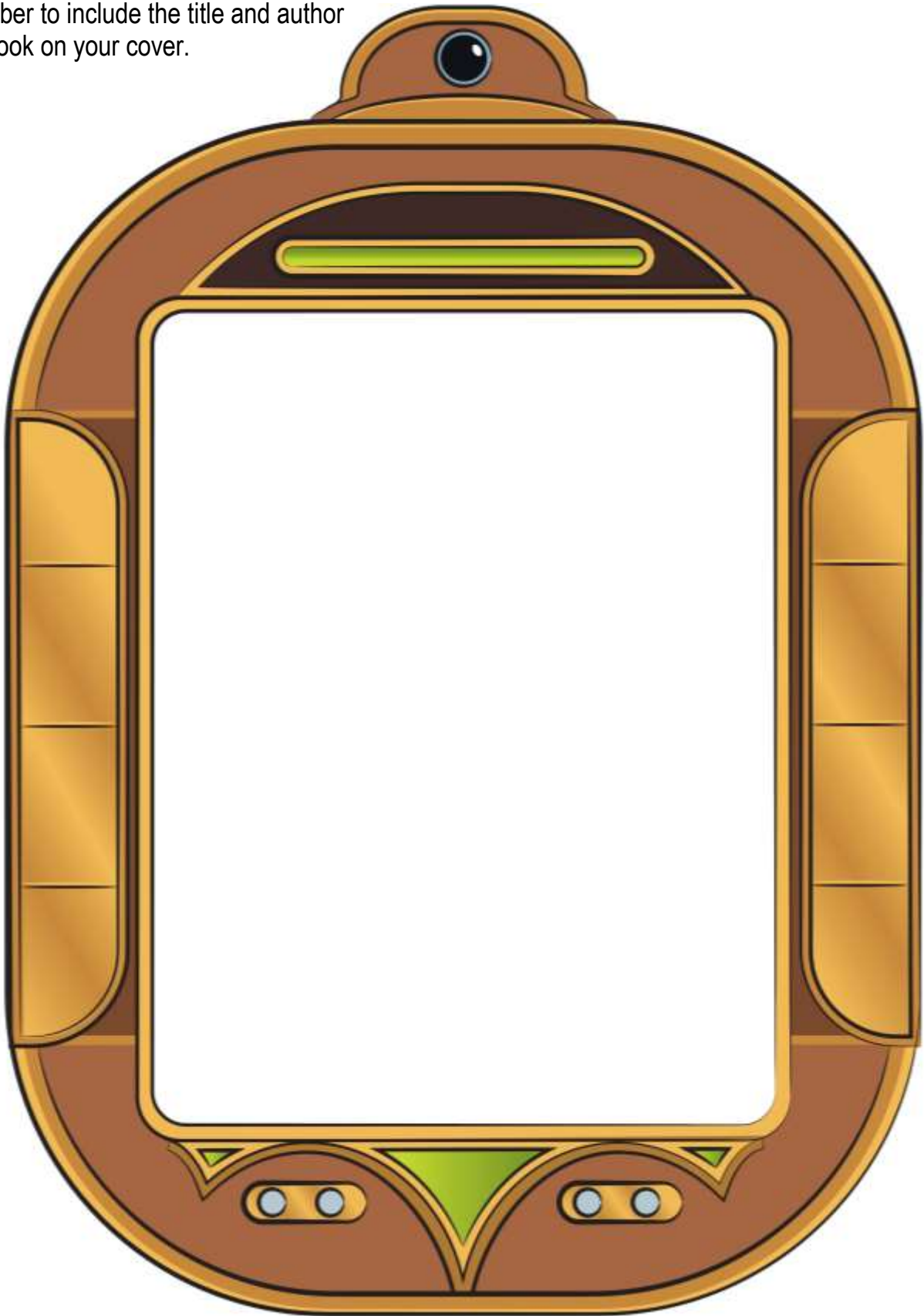

Share your finished book cover online. To post your picture to the Summer Reading Club online gallery go to www.summerreadingclub.org.au/theclub/upload_a_picture



SPOT THE DIFFERENCE

Searching for clues is the key to discovering hidden treasures and lost worlds! Can you spot the 11 differences between these SRC Adventurers?



1. _____

6. _____

2. _____

7. _____

3. _____

8. _____

4. _____

9. _____

5. _____

10. _____

11. _____



A-MAZE-ING ADVENTURES

Can you find your way through the maze to the lost artefacts?

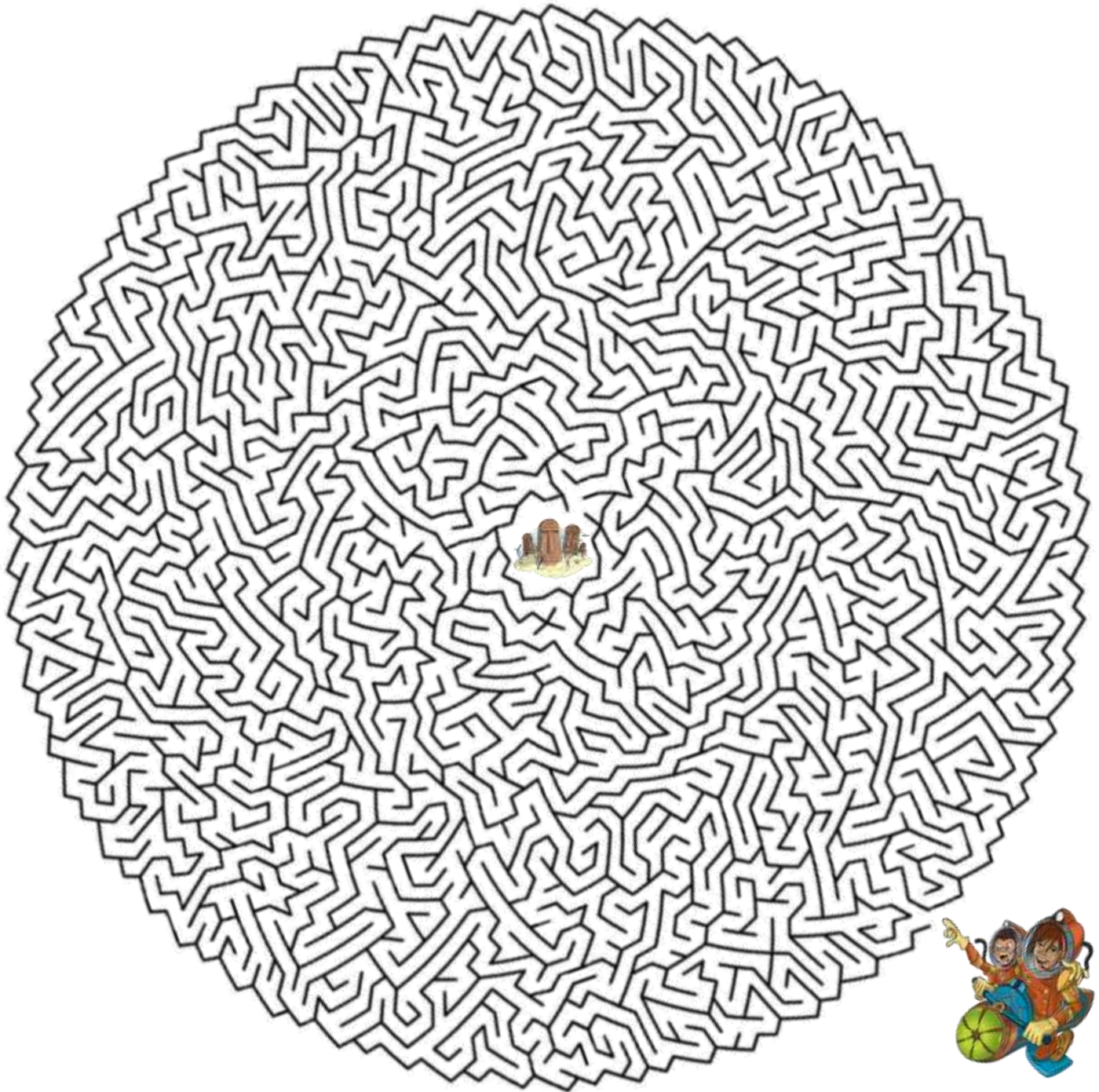

NOTE: This activity is not licensed under Creative Commons Attribution. This puzzle is ©2005-2014 by KrazyDad.com and included per KrazyDad.com reproduction guidelines. KrazyDad Tough Mazes, Book 9, Maze #13 http://krazydad.com/mazes/sfiles/KD_Mazes_TF_v9.pdf



COLOUR-N-DRAW

What other hidden treasures can you add to this picture? Add what you think is missing!

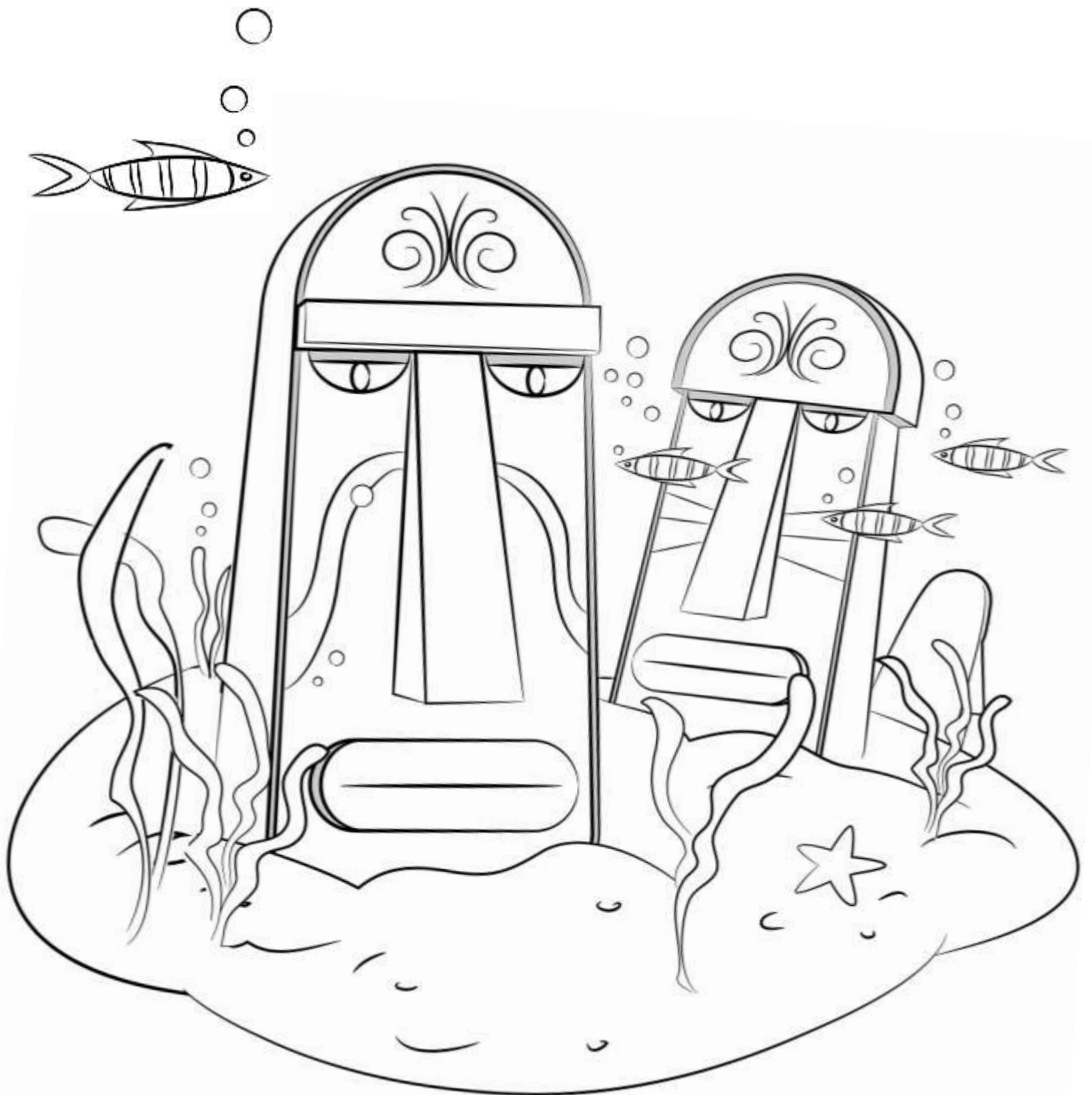

COMPLETE THE PICTURE

Using the picture as a guide, can you finish the picture below?

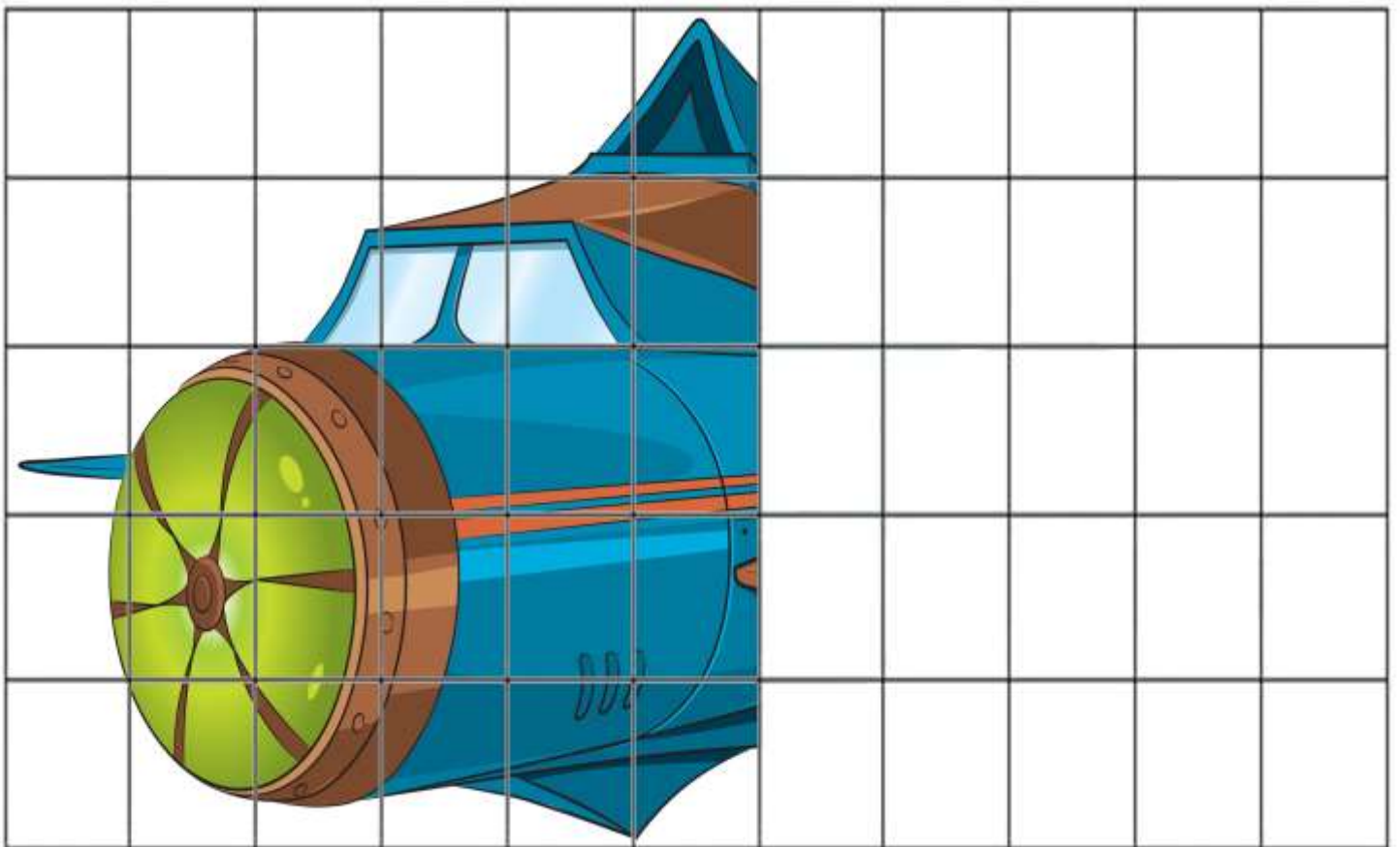
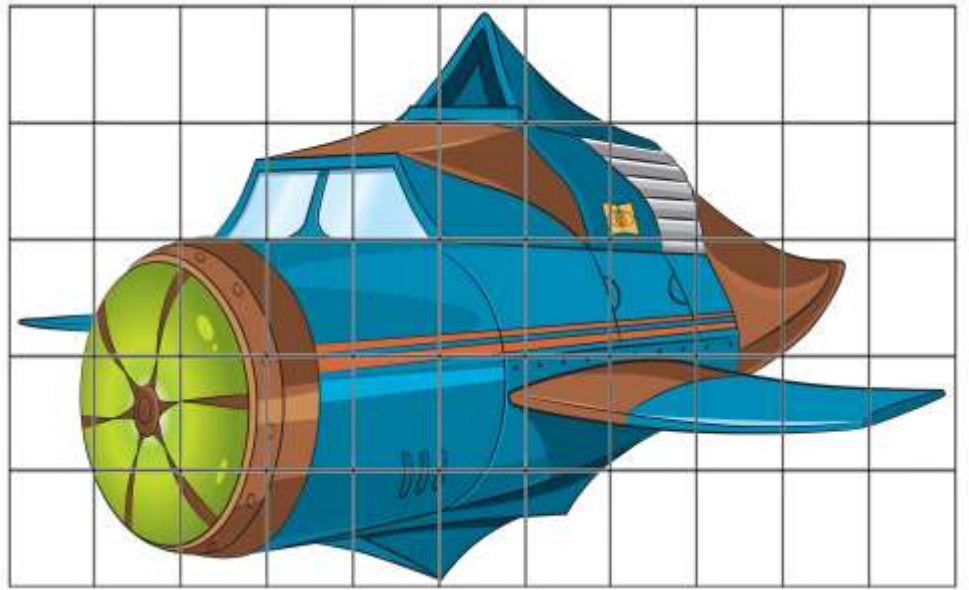

CONTROL PANEL

The diagrammatic cipher below substitutes symbols for letters. It uses tic-tac-toe boards and two X's. Use the line shapes that surround each letter (and including a dot where needed) to decipher the commands on the ship's control panel.

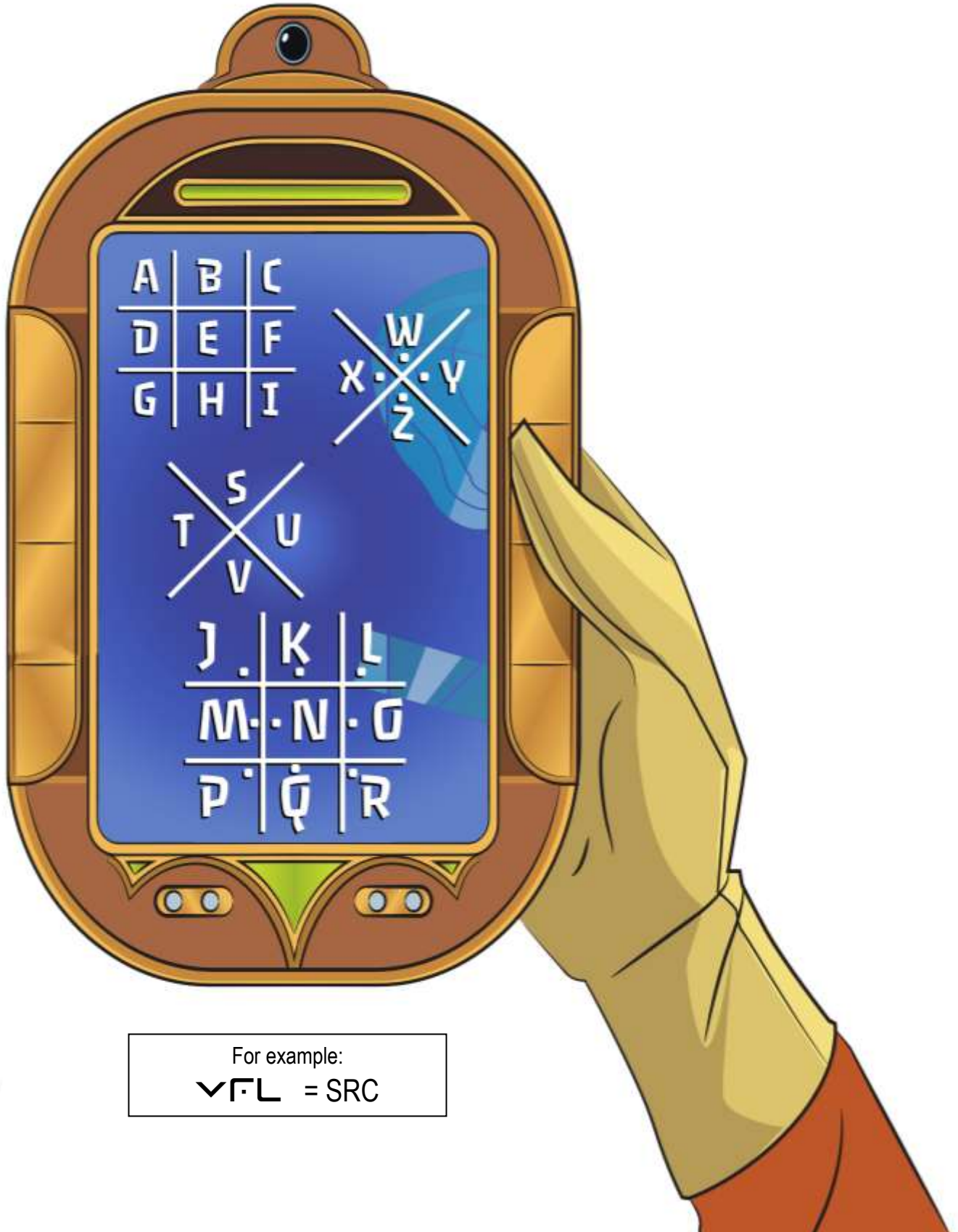

For example:
 $\surd \ulcorner \lrcorner = SRC$

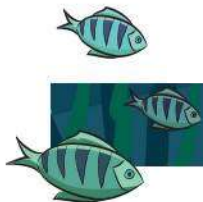

זִשׁוּפֶה

הָ

זִשׁוּפֶה

פֶּשׁוּב

פֶּשׁוּב

פֶּשׁוּב

חֶהֶח

פֶּשׁוּב

חֶהֶח

פֶּשׁוּב

חֶהֶח

פֶּשׁוּב

פֶּשׁוּב

פֶּשׁוּב

פֶּשׁוּב

פֶּשׁוּב

פֶּשׁוּב

פֶּשׁוּב

פֶּשׁוּב

פֶּשׁוּב

פֶּשׁוּב



MIX-N-MATCH

Can you identify which SRC Adventures are the same?



HIDDEN WORDS SEARCH

Can you find all 15 of these words?

Atlantis
Bermuda Triangle
Deep Ocean

Dinosaurs
Dragon
Hidden

Identity
Journey
Lost Worlds

Quest
Secret
Shipwreck

Space
Survival
Unknown

H	W	G	A	C	N	D	Q	W	H	E	A	B	W	U
V	S	A	S	J	W	E	Z	U	M	B	I	E	E	C
U	W	D	E	Y	T	I	T	N	E	D	I	R	X	Y
N	P	E	C	C	T	E	C	A	P	S	D	M	B	E
K	C	E	R	W	P	I	H	S	Y	D	T	U	I	N
N	T	P	E	A	B	J	R	K	T	L	V	D	E	R
G	I	G	T	E	F	U	J	U	R	R	Y	A	H	U
W	F	C	V	G	A	M	D	G	N	G	R	T	S	G
N	S	E	C	S	B	F	Q	G	Z	W	P	R	F	J
S	D	A	G	B	M	Q	G	T	L	T	Z	I	U	Y
S	U	N	A	T	L	A	N	T	I	S	R	A	I	M
W	I	S	R	I	R	E	G	M	N	G	T	N	D	I
D	E	H	I	D	D	E	N	I	G	L	H	G	E	Y
S	U	R	V	N	E	E	T	E	P	X	W	L	P	V
L	E	S	U	R	V	I	V	A	L	J	L	E	G	W



MISSING PIECES

Use the image below to help you finish this picture.

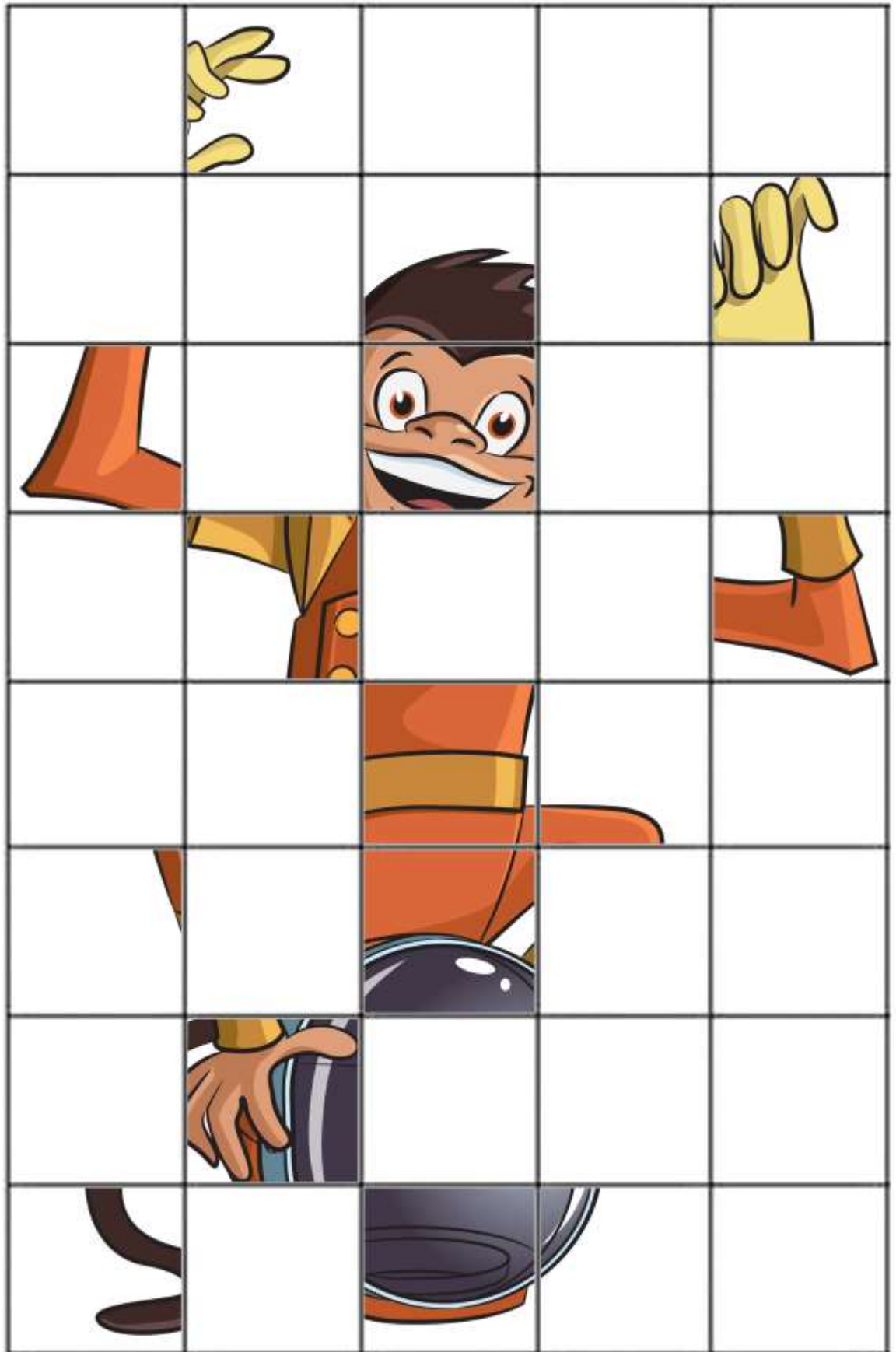

LOST WORLDS CROSSWORD

Use the clues and the titles from the SRC Primary Great Reads list to solve the crossword puzzle. The list is available for download from the Summer Reading Club website.

Go to <http://www.summerreadingclub.org.au/theclub/primary/great-reads>

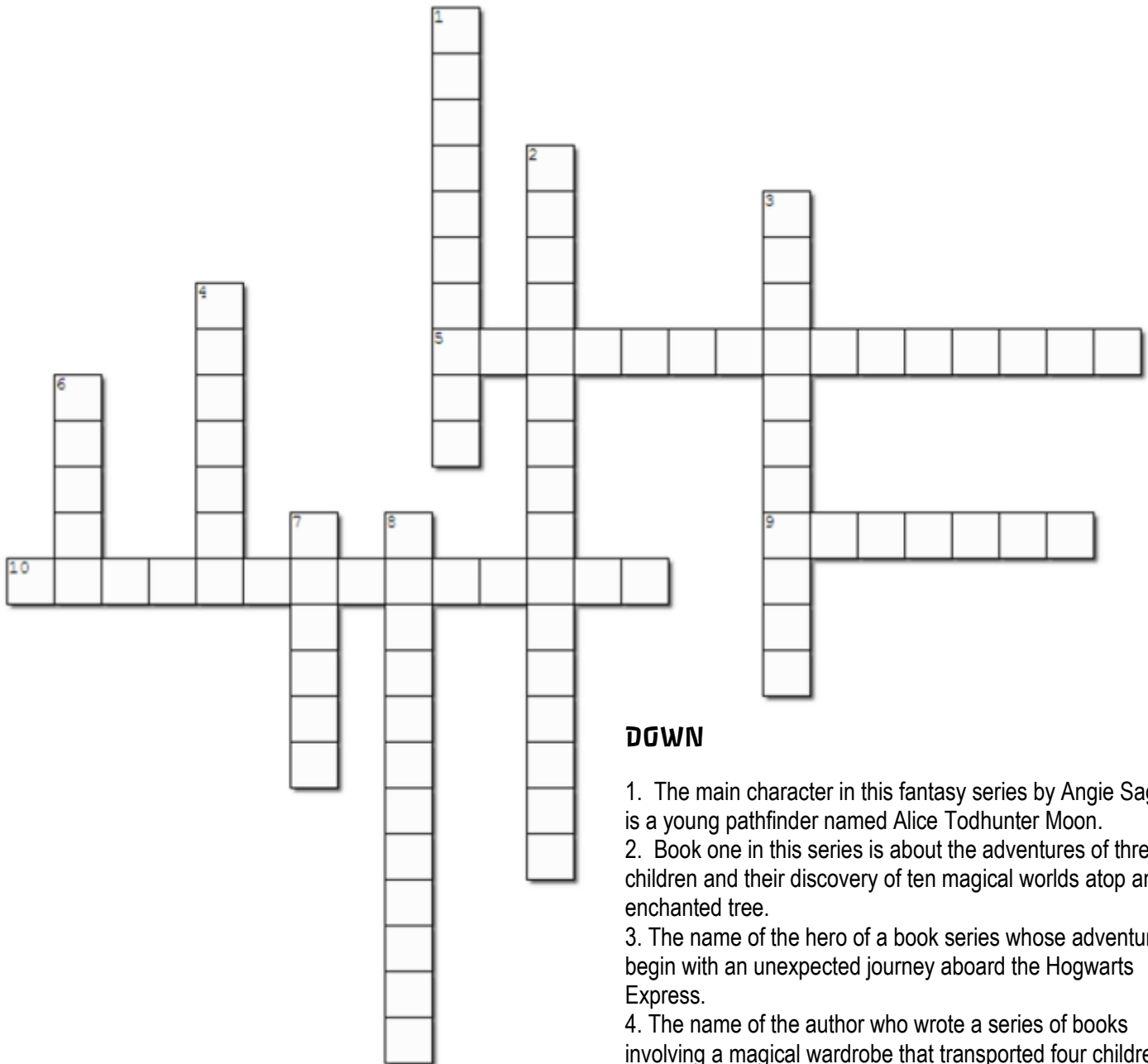

ACROSS

5. A novel that encompasses time travel, science, knights and dinosaurs.
9. This graphic novel series is illustrated by Brisbane based illustrator James Brouwer.
10. Although this young author's father was more of a crocodile hunter, his book series is based on adventures with a different kind of prehistoric reptile.

DOWN

1. The main character in this fantasy series by Angie Sage is a young pathfinder named Alice Todhunter Moon.
2. Book one in this series is about the adventures of three children and their discovery of ten magical worlds atop an enchanted tree.
3. The name of the hero of a book series whose adventures begin with an unexpected journey aboard the Hogwarts Express.
4. The name of the author who wrote a series of books involving a magical wardrobe that transported four children to the lost world of Narnia.
6. This Australian book series is co-written by a mother and daughter.
7. _____ and *the Dragon* is the tale of a young Japanese girl and her special relationship with dragons.
8. Book one in this new series by Holly Black and Cassandra Clare follows Callum Hunt, a child apprentice in a world where apprentices train to be warriors and dark magicians seek to defeat even death.



SOLUTIONS

Spot the Difference p4

1. Tank tube removed
2. Head light on helmet removed
3. Top bolt on helmet removed
4. Bottom bolt on helmet removed
5. Front scooter symbol removed
6. Top line on scooter is a different colour
7. Front line on scooter is a different colour
8. Symbol on shirt removed
9. Eye colour is different
10. Microphone removed
11. Seat trim colour is different



Control Panel p9

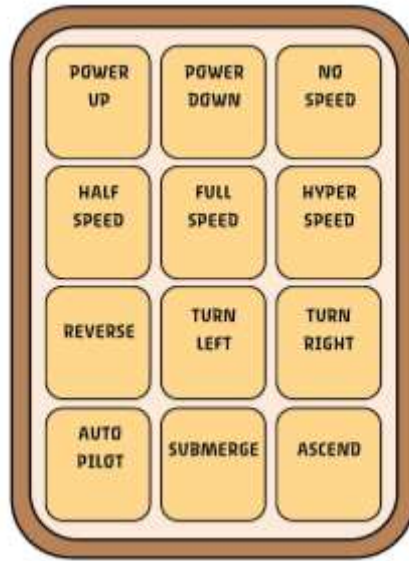

Adventure Search p11

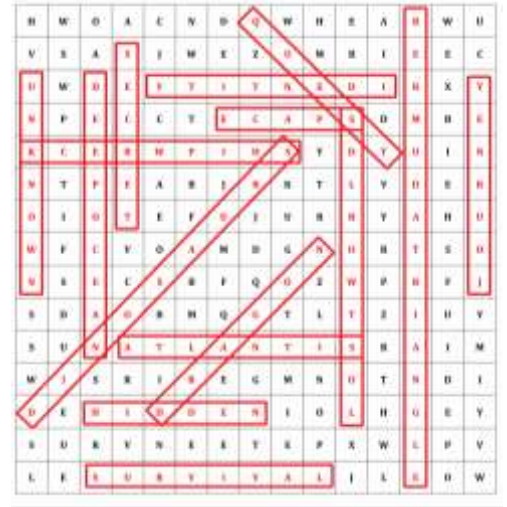

Mix and Match p10

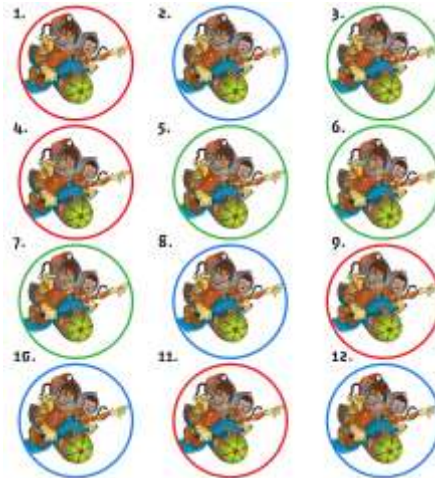

A-Maze-ing Adventures p5

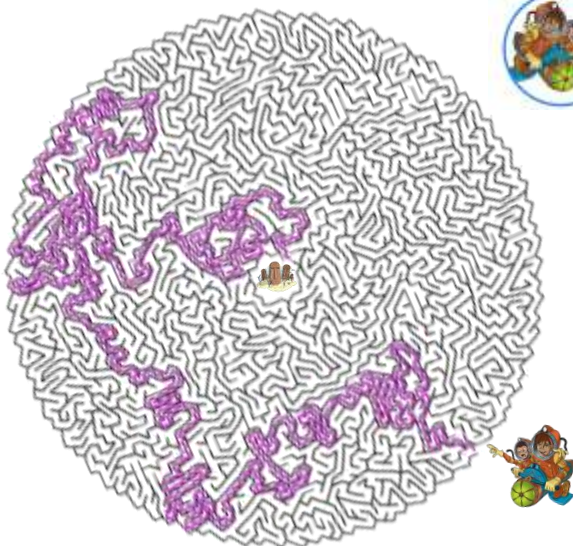

from <http://krazydad.com/mazes/answers/index.php?fmt=TF&book=9&puzn=13>

Adventure Crossword p13

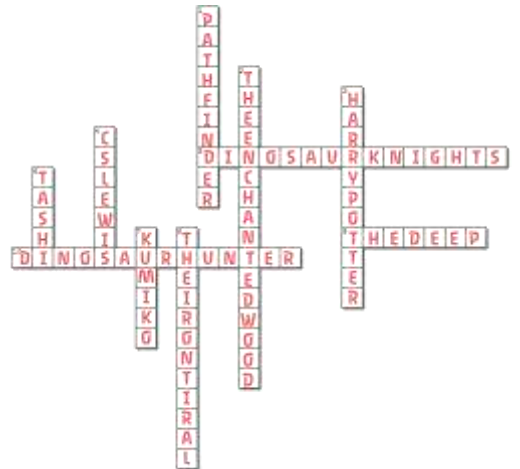

DOWN

1. Pathfinder
2. The Enchanted Wood
3. Harry Potter
4. C.S. Lewis
6. Tashi
7. Kumiko
8. The Iron Trial

ACROSS

5. Dinosaur Knights
9. The Deep
10. Dinosaur Hunter



		From:
To:		
		Stamp

		From:
To:		
		Stamp

SRC POSTCARDS!

Use these postcards to share your Summer Reading Adventures with family and friends. Who will you send your postcards to?

1. Colour-in the postcard or draw a picture of your Summer Reading Club Adventures
2. Cut out the postcard
3. Write your address in the FROM box
4. Write the address of where you want your postcard to go to in the TO box
5. Write or draw about your adventures on the back of the postcard
6. Put a stamp on the card
7. Put your postcard in the mail!

You can send a virtual postcard to the Summer Reading Club gallery. Once your postcard is complete, scan and upload it to: www.summerreadingclub.org.au/theclub/upload a picture

		From:
To:		
		Stamp

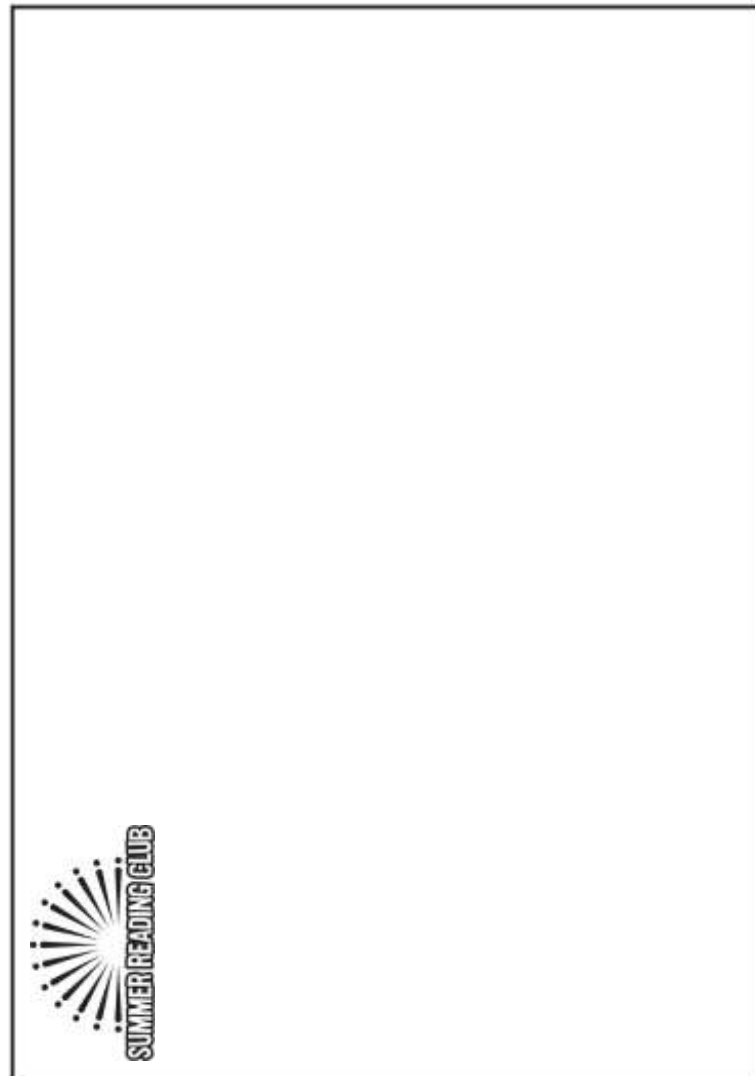
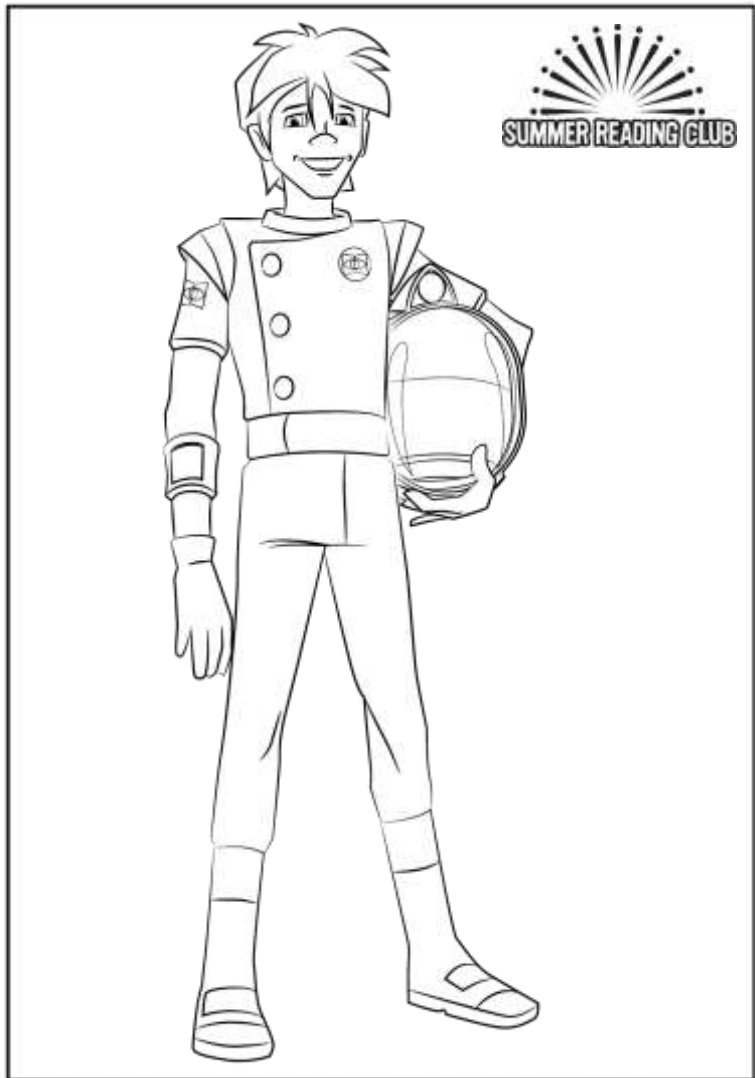
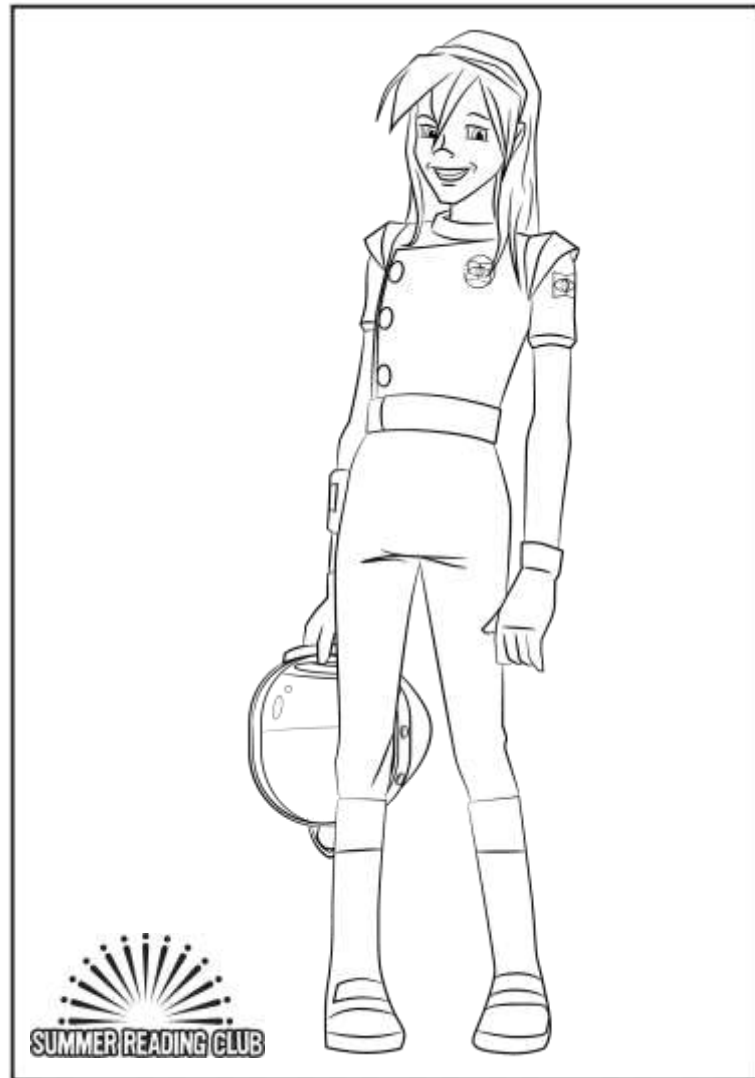

www.summerreadingclub.org.au
**Summer
Reading
Club**

© State Library of Queensland 2015

Unless otherwise indicated the activities and images in this booklet are licensed under a Creative Commons Attribution 3.0 Australia license. You are free to copy, communicate and adapt this work, so long as you attribute State Library of Queensland.



For more information see
<http://creativecommons.org/licenses/by/3.0/au>

Questions regarding the content in this booklet can be directed to summerreadingclub@slq.qld.gov.au