

AutoCAD Mechanical 2010

# Getting Started

The Autodesk logo is displayed in white text on a black rectangular background. The word "Autodesk" is written in a bold, sans-serif font, oriented vertically from bottom to top.

© 2009 Autodesk, Inc. All Rights Reserved. Except as otherwise permitted by Autodesk, Inc., this publication, or parts thereof, may not be reproduced in any form, by any method, for any purpose.

Certain materials included in this publication are reprinted with the permission of the copyright holder.

#### **Trademarks**

The following are registered trademarks or trademarks of Autodesk, Inc., in the USA and other countries: 3DEC (design/logo), 3December, 3December.com, 3ds Max, ADI, Alias, Alias (swirl design/logo), AliasStudio, AliasWavefront (design/logo), ATC, AUGI, AutoCAD, AutoCAD Learning Assistance, AutoCAD LT, AutoCAD Simulator, AutoCAD SQL Extension, AutoCAD SQL Interface, Autodesk, Autodesk Envision, Autodesk Insight, Autodesk Intent, Autodesk Inventor, Autodesk Map, Autodesk MapGuide, Autodesk Streamline, AutoLISP, AutoSnap, AutoSketch, AutoTrack, Backdraft, Built with ObjectARX (logo), Burn, Buzzsaw, CAiCE, Can You Imagine, Character Studio, Cinestream, Civil 3D, Cleaner, Cleaner Central, ClearScale, Colour Warper, Combustion, Communication Specification, Constructware, Content Explorer, Create>what's>Next> (design/logo), Dancing Baby (image), DesignCenter, Design Doctor, Designer's Toolkit, DesignKids, DesignProf, DesignServer, DesignStudio, DesignStudio (design/logo), Design Web Format, Discreet, DWF, DWG, DWG (logo), DWG Extreme, DWG TrueConvert, DWG TrueView, DXF, Ecotect, Exposure, Extending the Design Team, Face Robot, FBX, Filmbox, Fire, Flame, Flint, FMDesktop, Freewheel, Frost, GDX Driver, Gmax, Green Building Studio, Heads-up Design, Heidi, HumanIK, IDEA Server, i-drop, ImageModeler, iMOUT, Incinerator, Inferno, Inventor, Inventor LT, Kaydara, Kaydara (design/logo), Kynapse, Kynogon, LandXplorer, LocationLogic, Lustre, Matchmover, Maya, Mechanical Desktop, Moonbox, MotionBuilder, Movimento, Mudbox, NavisWorks, ObjectARX, ObjectDBX, Open Reality, Opticore, Opticore Opus, PolarSnap, PortfolioWall, Powered with Autodesk Technology, Productstream, ProjectPoint, ProMaterials, RasterDWG, Reactor, RealDWG, Real-time Roto, REALVIZ, Recognize, Render Queue, Retimer,Reveal, Revit, Showcase, ShowMotion, SketchBook, Smoke, Softimage, Softimage|XSI (design/logo), SteeringWheels, Stitcher, Stone, StudioTools, Topobase, Toxik, TrustedDWG, ViewCube, Visual, Visual Construction, Visual Drainage, Visual Landscape, Visual Survey, Visual Toolbox, Visual LISP, Voice Reality, Volo, Vtour, Wire, Wiretap, WiretapCentral, XSI, and XSI (design/logo).

The following are registered trademarks or trademarks of Autodesk Canada Co. in the USA and/or Canada and other countries: Backburner,Multi-Master Editing, River, and Sparks.

The following are registered trademarks or trademarks of MoldflowCorp. in the USA and/or other countries: Moldflow, MPA, MPA (design/logo),Moldflow Plastics Advisers, MPI, MPI (design/logo), Moldflow Plastics Insight,MPX, MPX (design/logo), Moldflow Plastics Xpert.

All other brand names, product names or trademarks belong to their respective holders.

#### **Disclaimer**

THIS PUBLICATION AND THE INFORMATION CONTAINED HEREIN IS MADE AVAILABLE BY AUTODESK, INC. "AS IS." AUTODESK, INC. DISCLAIMS ALL WARRANTIES, EITHER EXPRESS OR IMPLIED, INCLUDING BUT NOT LIMITED TO ANY IMPLIED WARRANTIES OF MERCHANTABILITY OR FITNESS FOR A PARTICULAR PURPOSE REGARDING THESE MATERIALS.

Published by:  
Autodesk, Inc.  
111 McInnis Parkway  
San Rafael, CA 94903, USA

# Contents

<b>Chapter 1</b>	<b>Introduction</b> . . . . .	<b>1</b>
	Why Use this Guide . . . . .	1
	Additional Resources . . . . .	1
	Before You Begin . . . . .	2
<b>Chapter 2</b>	<b>Get Familiar with the Work Area</b> . . . . .	<b>3</b>
	AutoCAD Mechanical User Interface . . . . .	3
	Workspace Settings . . . . .	5
	Drawing File Types . . . . .	9
<b>Chapter 3</b>	<b>Drawing Commands in AutoCAD Mechanical</b> . . . . .	<b>11</b>
	Drawing Commands . . . . .	11
	Draw Construction Lines . . . . .	13
	Create Holes . . . . .	14
	Create Countersink Holes . . . . .	18
	Create Hatch Patterns . . . . .	20
	Draw a Rectangle . . . . .	22
	Draw a Centerline Pattern . . . . .	23
	Draw Section Lines . . . . .	24
	Create Chamfers . . . . .	25
<b>Chapter 4</b>	<b>Modify Drawings with Power Commands</b> . . . . .	<b>27</b>

	Power Commands . . . . .	27
<b>Chapter 5</b>	<b>Generate Standard Parts . . . . .</b>	<b>31</b>
	Standard Parts Content . . . . .	31
	Content Libraries Navigation . . . . .	32
	Resize the Panels . . . . .	35
	Insert Screw Components . . . . .	36
	Insert Fasteners . . . . .	40
	Edit Standard Parts . . . . .	41
	Projected Views of Standard Parts . . . . .	42
	Change Representations . . . . .	43
<b>Chapter 6</b>	<b>Organize Objects with Layers . . . . .</b>	<b>45</b>
	Predefined Mechanical Layers . . . . .	45
	Mechanical Layer Manager . . . . .	48
	Predefined Object Properties . . . . .	50
	Object Property Settings . . . . .	52
<b>Chapter 7</b>	<b>Create Hidden Lines . . . . .</b>	<b>57</b>
	Associative Hidden Lines . . . . .	57
<b>Chapter 8</b>	<b>Reusable Detailing Tools . . . . .</b>	<b>61</b>
	Chamfers . . . . .	61
	Title Block . . . . .	62
	Associative Detail View . . . . .	63
<b>Chapter 9</b>	<b>Power Dimensions . . . . .</b>	<b>67</b>
	Create Mechanical Dimensions . . . . .	67
	Multiple Dimensions . . . . .	71
	Edit Dimensions . . . . .	73
<b>Chapter 10</b>	<b>Add Part Lists and Balloons . . . . .</b>	<b>75</b>
	Create Part References . . . . .	75
	About Bills of Materials (BOMs) . . . . .	77
	Create Balloons . . . . .	78
	Create Parts Lists . . . . .	79
<b>Chapter 11</b>	<b>International Drafting Standards . . . . .</b>	<b>81</b>
	Set Drafting Standards . . . . .	81
	Create Custom Standards . . . . .	82
	Scale for Text and Symbols . . . . .	84
	Standard-based Annotations . . . . .	86

**Index** . . . . . **87**



# Introduction

# 1

AutoCAD® Mechanical software extends the capabilities of AutoCAD® so that you can quickly create and manage mechanical drawings.

This *Getting Started* guide provides concepts and short exercises to help you get started with AutoCAD Mechanical.

## Why Use this Guide

As you make the transition from AutoCAD to AutoCAD Mechanical, this guide provides an introduction to the most commonly used features of AutoCAD Mechanical. Use it to learn the basic features so you can start working quickly.

This guide focuses on:

- Important concepts to get started working with AutoCAD Mechanical.
- How to use mechanical features to draw, modify, organize, and annotate your drawings efficiently.

If you are new to AutoCAD Mechanical, we recommend that you follow the lessons in this guide from start to finish.

## Additional Resources

From the Help menu, you can access the following resources:

- **Help** provides detailed concepts, procedures, and reference information for all features. To access the Help topics, select Help ► Mechanical Help Topics on the menu bar on the Mechanical Classic workspace. You can also press F1 at the Command prompt, in a dialog box, or at a prompt within a command to display Help information.

- **Mechanical Feature Workshop** demonstrates the top 10 most important features in AutoCAD Mechanical.
- **Learning Resources** link to additional resources about AutoCAD Mechanical.

## Before You Begin

Before you begin, we recommend that you have a working knowledge of Microsoft® operating systems and how to use basic AutoCAD commands.

You must have AutoCAD Mechanical installed and licensed on your computer system to complete the lessons in this guide.

The exercise files are in the Getting\_Started folder.

---

**NOTE** The path to the folder containing Getting\_Started files is:

- **Windows Vista®:** *C:\Users\Public\Documents\Autodesk\ACADM 2010\Acadm\Getting\_Started*
- **Windows® XP:** *C:\Documents and Settings\All Users\Documents\Autodesk\ACADM 2010\Acadm\Getting\_Started*

---

**NOTE** All AutoCAD commands and features are available while working on your drawings in AutoCAD Mechanical.

---



# Get Familiar with the Work Area

# 2

This chapter shows how you can quickly get acquainted with the AutoCAD® Mechanical work area. It also shows you how to work with the AutoCAD Mechanical user interface, workspaces, and drawing file types.

## AutoCAD Mechanical User Interface

When you start AutoCAD Mechanical, the Mechanical workspace appears as the current work area. Use this workspace to learn to use AutoCAD Mechanical. Refer to the following image.

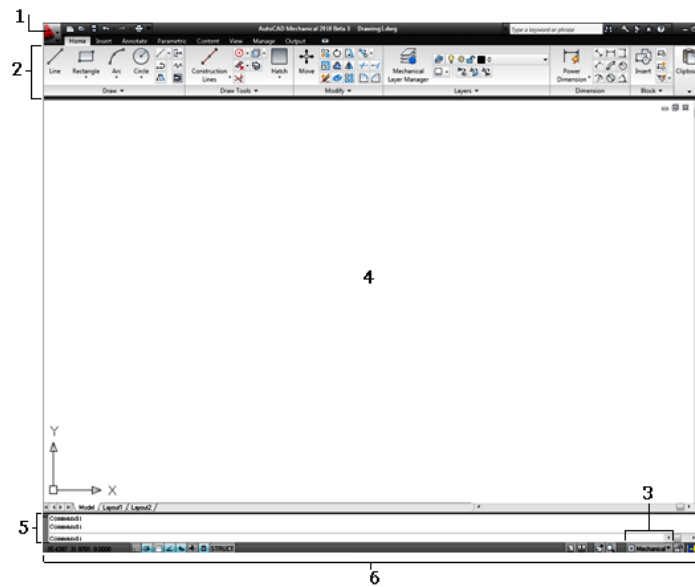

## About the Work Area

The work area consists of the following components:

### 1 Menu Browser button

Click this button to access a complete list of commands in the menu bar and to search for Help information.

### 2 Ribbon

The ribbon contains commands in a set of tabs for performing tasks. It is a mix of AutoCAD® and AutoCAD Mechanical commands.

### 3 Workspaces toolbar

This toolbar shows the current selection of workspaces. You can also switch to other workspaces while working on your drawings.

### 4 Drawing area

The drawing area is where you create and place your drawing objects.

### 5 Command line

The command line shows the command that is executing, if any, and prompts or messages from that command. You can view and select options while running commands to create or edit objects in your drawing.

## 6 Status bar

Contains the application and drawing status bars for you to view and switch drawing settings, helping you to work efficiently on your design.

---

**NOTE** Whether you are running AutoCAD Mechanical in Windows® XP or Windows Vista®, 32-bit or 64-bit versions, AutoCAD Mechanical shows a similar work area.

---

## Workspace Settings

Selecting a workspace controls the display of the predefined menus, toolbars, palettes, and dashboards for quick and easy access to commands. You can choose a convenient workspace to start working on your drawing, or customize and save your own workspaces according to your project requirements.

You can switch among all three workspaces, Mechanical, Structure, and Mechanical Classic using the Workspaces toolbar.

The predefined workspaces built into AutoCAD Mechanical are:

- Mechanical
- Structure
- Mechanical Classic

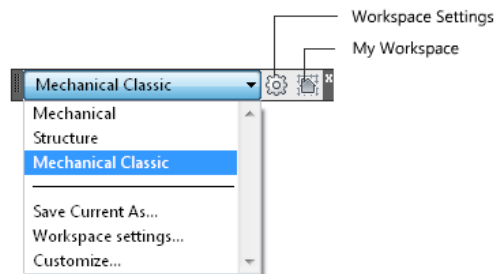

To set the current workspace, click  and select your workspace from the drop-down list under My Workspace. Switch back to your workspace by clicking the My Workspace icon on the Workspaces toolbar.

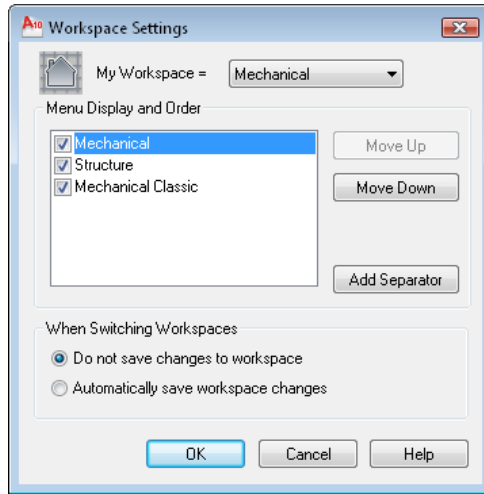

---

**NOTE** AutoCAD Mechanical automatically starts the last workspace you used, but not your workspace (My Workspace) the next time you launch the application.

To use your workspace, click  on the drawing Workspace toolbar.

---

**NOTE** If you add or remove any toolbars on the predefined workspace, these changes do not appear in the active workspace the next time you use that workspace. The changes appear when you select Automatically save workspace changes in the Workspace Settings dialog box.

---

### Switch Workspaces

You can switch between predefined and custom workspaces.

#### ■ Mechanical Workspace

The Mechanical workspace contains relevant Mechanical ribbon tabs and panels such as Draw, Draw Tools, Modify, Layers, Dimension, and Block for a beginner using AutoCAD Mechanical.

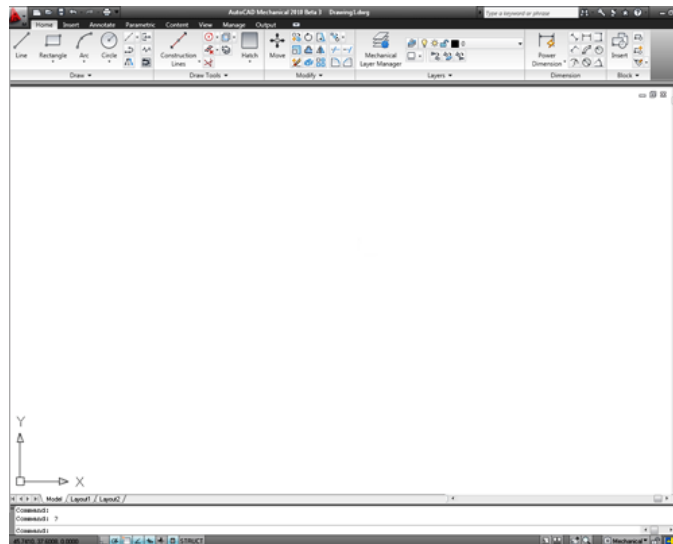

#### ■ Structure Workspace

Select the Structure workspace when you create structured objects in AutoCAD Mechanical. The program groups structured objects into parts, subassemblies, and assemblies for quick selection and modification.

The mechanical browser in the left pane appears when you select the structure workspace. Other relevant toolbars for structured objects appear when you work on structured objects.

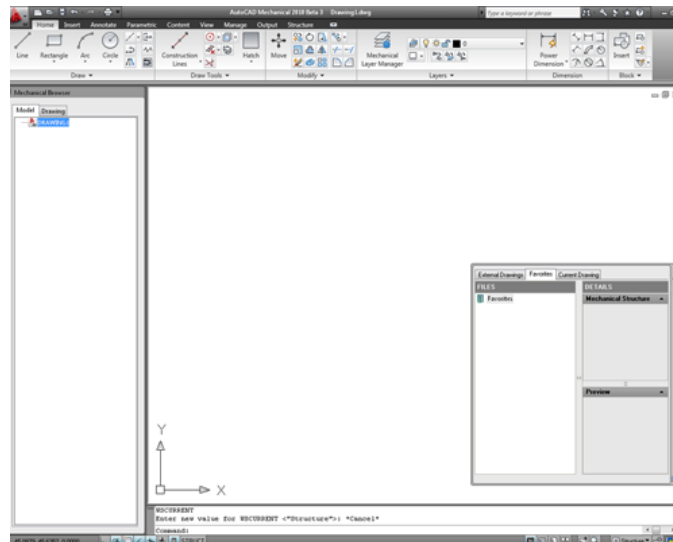

---

**NOTE** To use the Structure workspace, it is important to understand how mechanical structure works for your design. Learn more about mechanical structure from Mechanical Help, or the built-in Learning Mechanical Structure tutorial.

---

- **Mechanical Classic Workspace**  
The Mechanical Classic contains the most commonly used mechanical toolbars such as Mechanical Main, Draw, Modify, Design Tools, Mechanical Layer, Dimension, Content, Symbols, and Bill of Materials for you to create, organize, edit, and annotate your drawings in AutoCAD Mechanical.

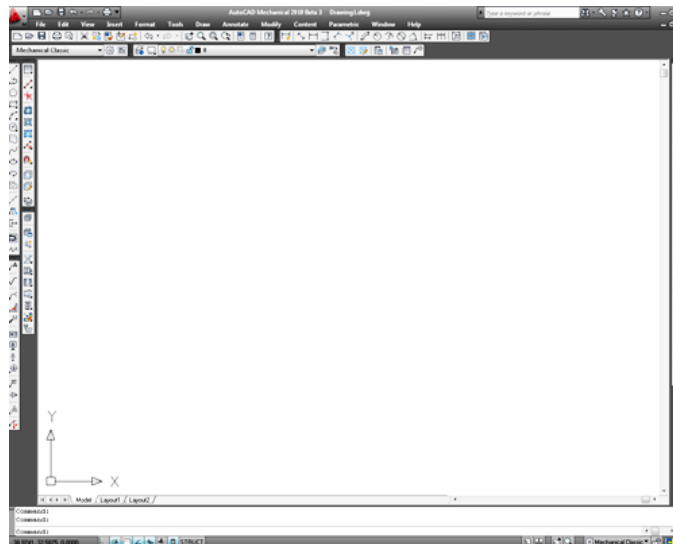

## Drawing File Types

AutoCAD Mechanical includes the complete installation of AutoCAD reinforced with a complete suite of 2D mechanical features.

You can use drawings created in AutoCAD in AutoCAD Mechanical. The program retains all entities when moving AutoCAD drawings to AutoCAD Mechanical. It maintains visual fidelity when exchanging drawings with older or 2009 versions of AutoCAD to AutoCAD Mechanical.

You can also save AutoCAD Mechanical drawings to formats from AutoCAD 2009 or earlier.





# Drawing Commands in AutoCAD Mechanical

# 3

Mechanical drawings consist of commonly used parts connected to other parts or features in a design. AutoCAD® Mechanical drawing commands provide more flexibility for creating these parts.

This chapter shows you how to create a part of an assembly efficiently using the primary AutoCAD® commands together with the extended AutoCAD Mechanical drawing commands.

## Drawing Commands

AutoCAD Mechanical provides several options for drawing commands. You can create specialty lines, circles, arcs, automatic centerlines, and other elements in your drawing. The drawing tools include more options for rectangles, arcs, and circles.

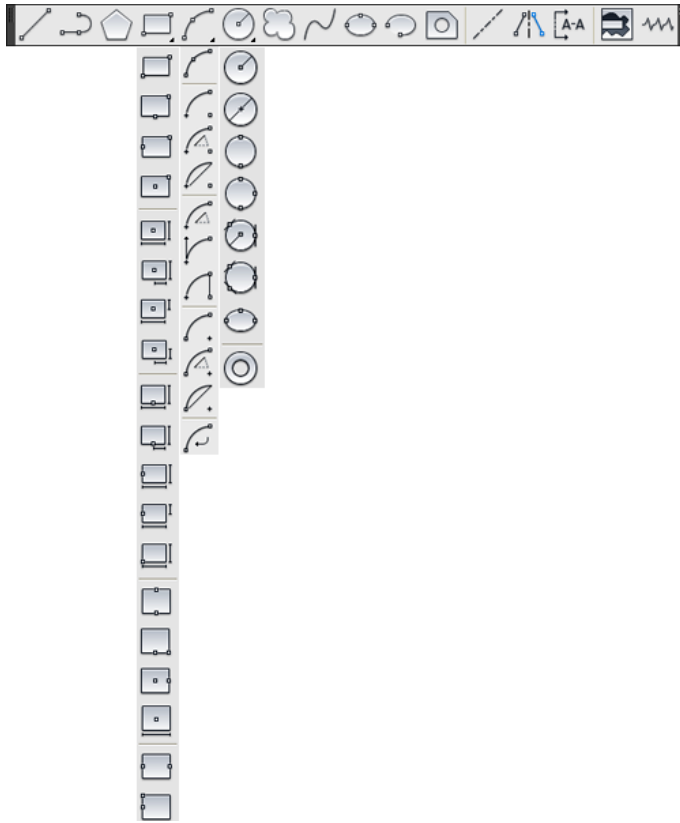

This chapter shows you how to create a part (a gland) using AutoCAD Mechanical Draw commands. Use the measurements in the following image for the exercises.

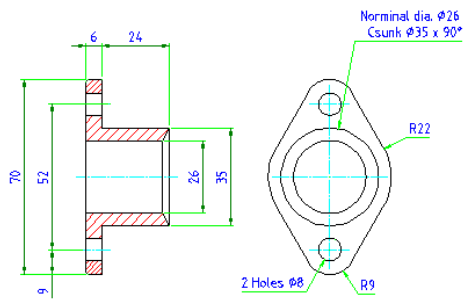

# Draw Construction Lines

AutoCAD Mechanical includes a full complement of construction lines for aligning drafting views.



Click Home tab ► Draw Tools panel ► Construction Lines  to open the Construction Lines dialog box.

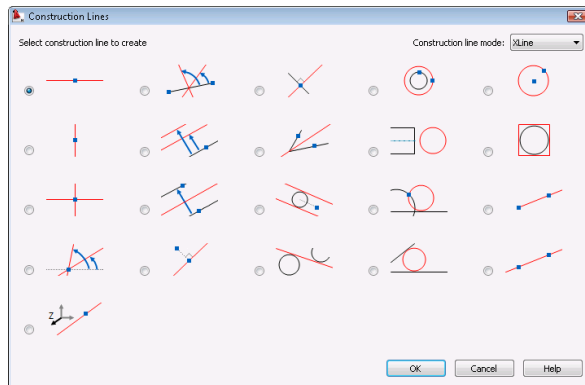

## Draw Construction Lines

- 1 Begin a **New** drawing based on the am\_iso template.

---

**NOTE** AutoCAD Mechanical includes eight drafting standard templates that control drafting elements such as layer settings, object properties, text heights and colors, and symbology formats. This lesson uses the ISO drafting standard.

---

- 2 Select the Mechanical workspace for this exercise.
- 3 Use the command Zoom ► All to show the entire page.
- 4 Based on the dimensions in the earlier image of the gland, use the **Line** command to create the front view of the gland.



5 Click Home tab ► Draw Tools panel ► Construction Lines drop-down

► Horizontal  to create horizontal construction lines aligned to the front view.

6 Click Home tab ► Draw Tools panel ► Construction Lines drop-down

► Vertical  to create a vertical construction line for the position of the side view. See the following image.

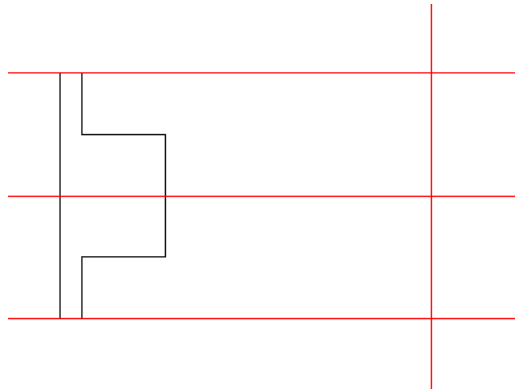

The program creates horizontal and vertical construction lines.

## Create Holes

In AutoCAD, you create holes using Line, Circle, Trim, and Modify commands. In AutoCAD Mechanical, the hole is a Power Object or mechanical object with attributes or internal information. Use AMTHOLE2D to create the hole.

## Create Holes

- 1 Click Content tab ► Holes panel ► Through Hole  to create a through hole.
- 2 Scroll to the bottom of the Details list, and select User Through Holes.
- 3 Select Front View.
- 4 Place a through hole with the diameter 8 mm, as specified.

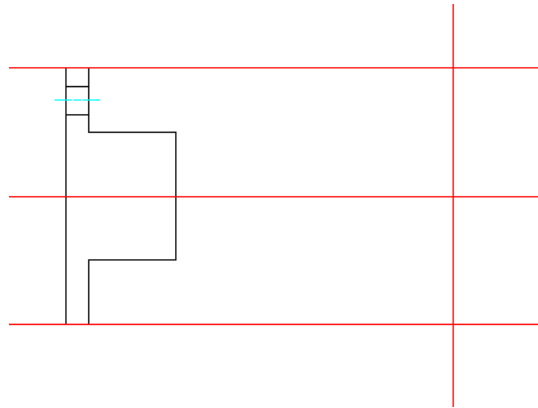

- 5 Click Home tab ► Modify panel ► Copy  to create another similar hole. The Power Copy command remembers the attributes of the Power Object and creates another hole of the same size, symmetrical to the first hole.

Use the Symmetry Power Snap selection in the Power Snap Settings dialog box to create a hole symmetrical to the first hole. When prompts for an

insertion point, hold SHIFT and right-click to select  in the context menu to open the Power Snap Settings dialog box. Select the Symmetry check box.

---

**NOTE** Click the check box Off for all other object snap settings.

---

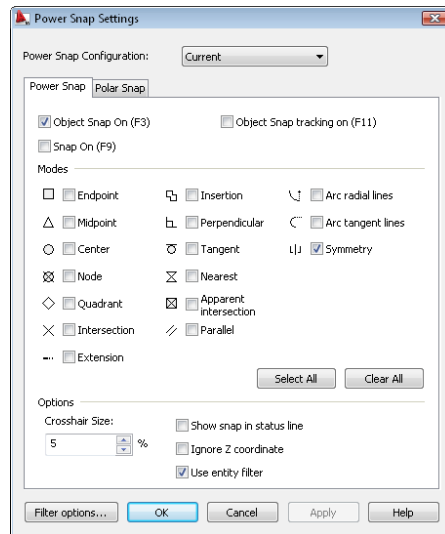

When inserting the hole, select the construction line at the center of the part for its symmetry point.

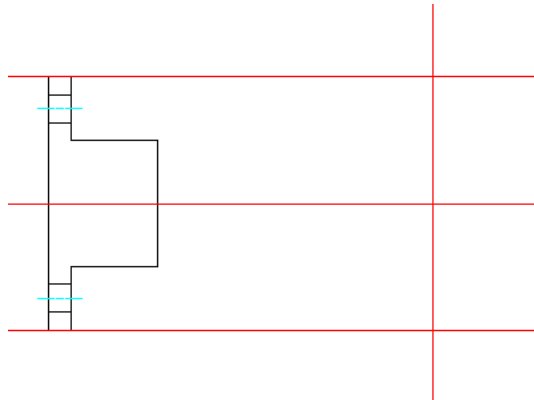

- 6 Use the Circle, Line, and Trim commands to draw the side view of the gland as shown in the following image. Draw the side view to full scale using the dimensions on the first page of this lesson.

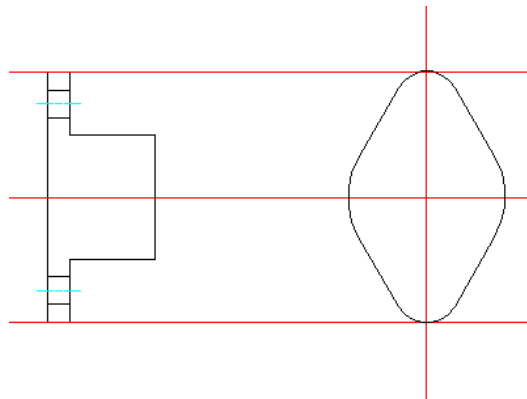

- 7 Click Content tab ► Tools panel ► Power View  to create a projected top view of the holes from the front view.

---

**NOTE** You can create two horizontal construction lines aligned from the front view for the positions of the holes on the side view.

---

- 8 Create the top view of the holes based on the front view (parent).
- 9 The program creates the top view of the holes.

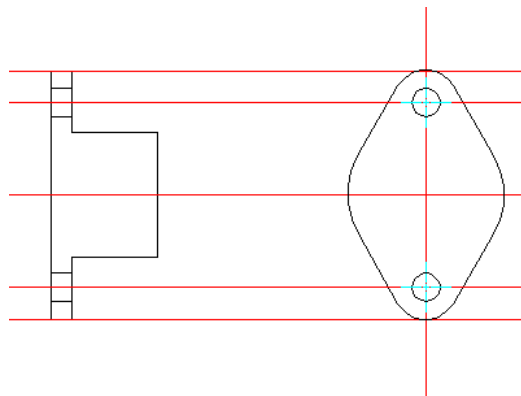

---

**NOTE** You can use Power View to create projected views of standard parts such as screws, bolts, and nuts. It quickly creates a top view from a side view, or a side view from a top view.

---

## Create Countersink Holes

Countersink holes are Power Objects or mechanical objects. Use AMCOUNTS2D to create a countersink hole. You can quickly change the size of countersink holes by using the Power Edit command.

### Create a Countersink Hole

- 1 Click Content tab ► Holes panel drop-down ► Countersink .
- 2 Create a countersink hole with nominal diameter 26 mm, countersink diameter 35 mm, and angle 90 degrees.
- 3 Specify its insertion point as shown in the following image.

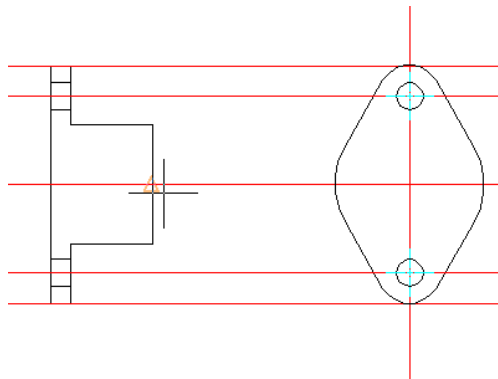

- 4 Enter 30 for the hole length and 180 degrees for the rotation angle.
- 5 Enter 26 for the nominal diameter, 35 for the countersink diameter, and 90 degrees for the angle, and then click Finish.
- 6 The program creates a countersink hole.



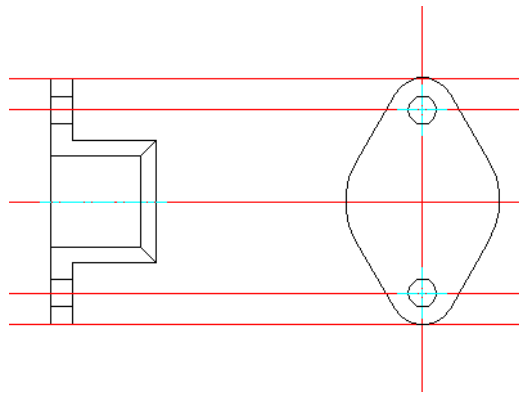

- 7 Click Content tab ► Tools panel ► Power View  to create the projected top view of the countersink hole from the front view.

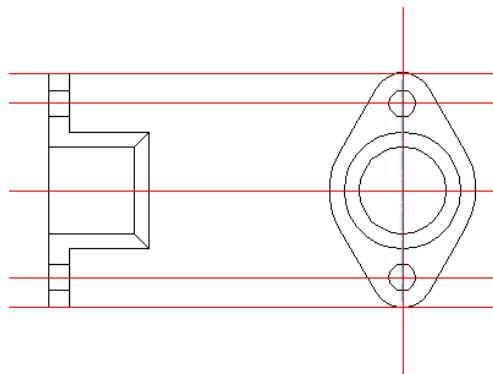

- 8 Click Home tab ► Draw Tools panel ► Erase all Construction Lines



- 9 The program creates a part (gland).

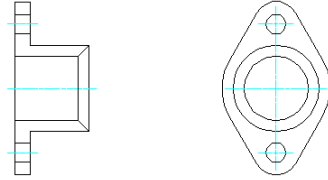

## Create Hatch Patterns

Hatches enable people using your mechanical drawings to distinguish between parts in the section or breakout views more easily. In AutoCAD Mechanical, there are three types of hatches: associative hatch, user-defined hatch, and predefined hatch.

Predefined hatches are for manufacturing drawings with parts of different sizes and shapes in an assembly. The program includes six predefined hatch patterns with left and right directions, at 45-degree and 135-degree angles, three hatch pattern widths, and one double-hatch pattern.



---

**NOTE** User-defined and predefined hatches are non-associative by default. To change both to be associative, select the Make Predefined Hatches Associative check box on the AM:Preferences tab of the Options dialog box.

---

### Create Hatch Patterns

For many parts in an assembly, you can apply predefined hatches quickly by selecting the part and using a Hatch menu command. For this exercise, select the User-defined hatch command.

- 1 Click Home tab ► Draw Tools panel ► Hatch drop-down ►

User-Defined Hatch  to create hatch pattern.

- 2 Select User-defined pattern in the Pattern Type list. Set 45 degrees for angle and 2.50 mm for Spacing in the Pattern properties list.
- 3 Click OK.

- 4 Click a point within the boundary area of the part to add the hatch pattern.

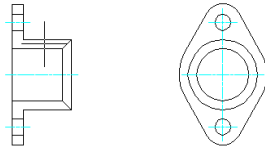

- 5 Press ENTER.

- 6 Click a point within the next boundary area to add the hatch pattern. See the following image.

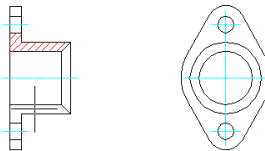

- 7 Press ENTER to repeat the command. Clear the Adapt hatch distance at less than five hatchlines check box in the Hatch dialog box. Doing so ensures consistent hatch spacing on the part.

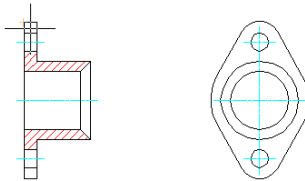

- 8 Press ENTER to repeat the command. Continue to add hatch patterns to the parts.

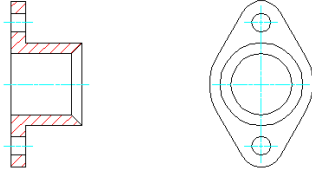

The program creates the hatch patterns.

## Draw a Rectangle

You can create rectangles and squares with the Rectangle command in AutoCAD Mechanical. This function gives you a convenient and flexible way to place rectangles at the specific positions with no further modification to your design.

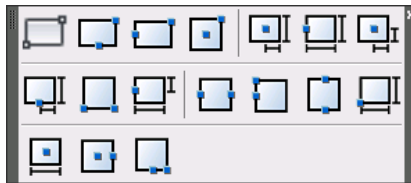

### Try It: Draw a Rectangle

You can select the rectangle from the Rectangle toolbar or press ENTER at the Rectangle command options to open the Rectangles dialog box.

For this exercise, attach a circular plate beside the gland you created. Select the rectangle with the height-middle insertion point. Locate its middle point, and specify its full base as 14 mm and its full height as 76 mm.

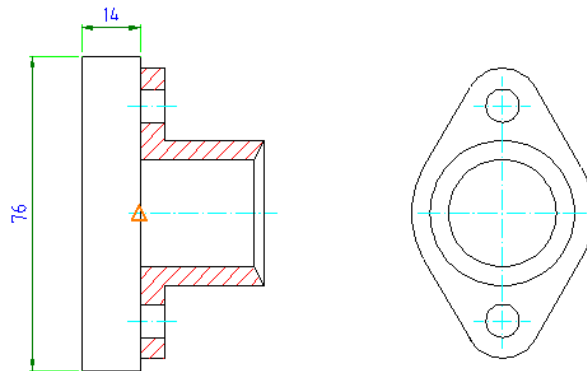
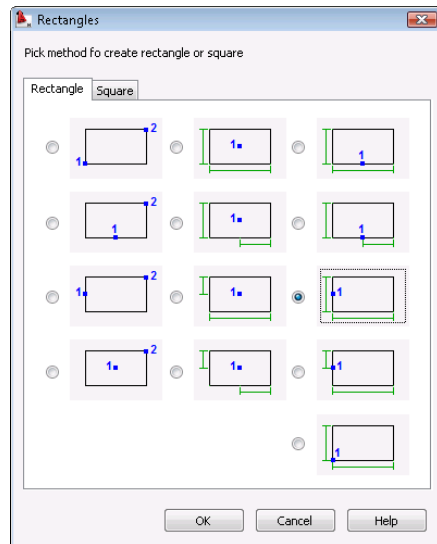

The program creates the rectangle and places it at the specified location.

## Draw a Centerline Pattern

Mechanical drawings often require centerlines and centerline crosses with or without holes, countersink holes, or counterbore holes. The Centerlines dialog box provides you with multiple ways to create centerlines and holes quickly.



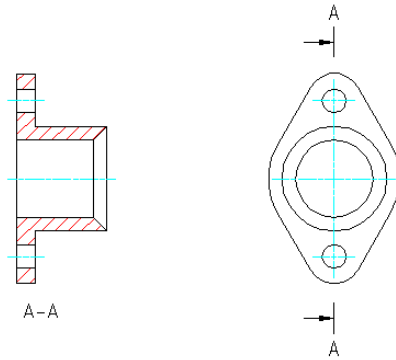

## Create Chamfers

Click Home tab ► Modify panel ► Chamfer  to create chamfers in AutoCAD Mechanical. As with AutoCAD, you can choose to trim or not to trim the geometry when you chamfer. Unlike AutoCAD, you can include dimensions when you chamfer. You can also configure the list of chamfer sizes for your drawings.

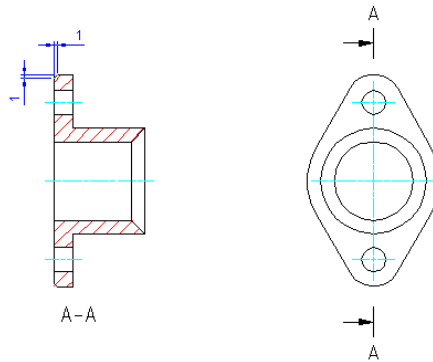





# Modify Drawings with Power Commands

# 4





Power Objects or mechanical objects in AutoCAD® Mechanical are objects that contain attributes. They include standard parts, symbol libraries, Power Dimensions, holes, hole charts, title blocks, balloons, part lists, and all objects created with AutoCAD Mechanical commands.

This chapter shows you how to create or modify Power Objects quickly with Power Commands.

## Power Commands

In AutoCAD Mechanical, a Power Object is an object with attributes. It contains relevant parameters that makes the object intelligent. For example, a screw has its screw size stored in its geometry, and a chamfer has its chamfer sizes stored in it.

Power Commands use this information to create, copy, and edit Power Objects quickly.

The Power commands include the Power Edit , Power Copy , Power Erase , Power Recall , and Power View .

Right-click at the drawing area to find these power commands on the context menu.

---

**NOTE** You can double-click any Power Object to activate the Power Edit command for modification. It automatically opens a dialog box where you can make changes.

---

### Edit the Hole

- 1 Double-click the existing hole (diameter 8 mm).

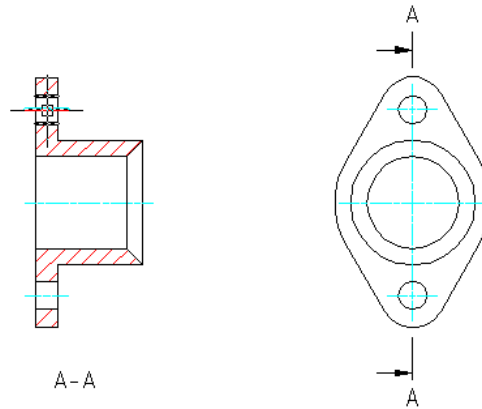

2 The User Through Holes - Nominal Diameter dialog box appears.

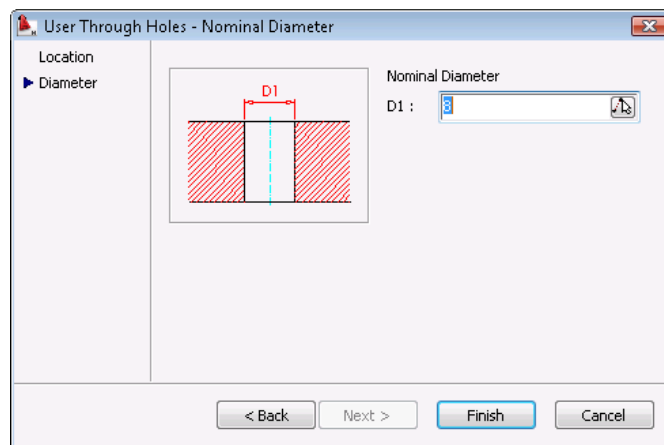

3 Change the diameter of the hole to 6 mm.

---

**NOTE** Changing the hole size of the front view does not automatically update the hole size of its related side view.

---

The geometry and its hole size change accordingly.

#### Edit the Countersink Hole

1 Double-click the countersink hole. The User Countersinks - Parameter for Countersinks dialog box appears.

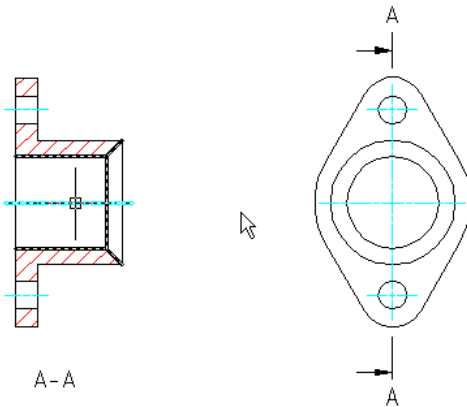

- 2 Change the countersink hole diameter to 30 and its nominal diameter to 20. Click OK to see the changes update automatically.
- 3 Undo the previous change.

#### Edit the Chamfer

- 1 Double-click the chamfer. The Chamfer dialog box appears.

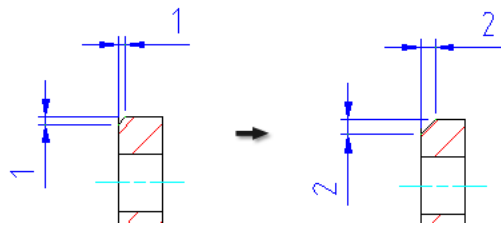

- 2 Change the chamfer length to 2 and click OK. Notice the chamfer and its dimension update to the new length.

---

**NOTE** You can use the Power Recall command to create another hole with the same parameters as the existing hole.

---

Try using the Power Recall, Power Copy, and Power View commands on this drawing.



# Generate Standard Parts

# 5

Manufacturing designs often include standard parts and features. These standard parts can include screws, nuts, washers, pins, rivets, bushings, and others. It is typically to find standard parts collected and published in libraries, and AutoCAD® Mechanical includes several such libraries. With AutoCAD Mechanical, you can insert standard parts from installed parts libraries directly into your drawings. If you cannot find any industry-standard part in the parts library for your design requirements, create custom parts and add them to your libraries as well.

AutoCAD Mechanical also includes many commonly used features such as undercuts, keyways, pre-drawn holes, blind holes, oblong holes, countersink holes, and counterbore holes. As with standard parts, you can add these elements easily into your designs.

This chapter describes how to generate standard parts for a sealed shaft unit.

## Standard Parts Content

This lesson shows you how to select and use industry-standard parts for your design. AutoCAD Mechanical includes standard part libraries from 18 manufacturers (AFNOR, ANSI, AS, BSI, CNS, CSN, DIN, GB, GOST, IS, ISO, JIS, KS, PN, SFS, SS, STN, and UNI). To use standard parts from a manufacturer, select that manufacturer during installation.

### Selected Standards

- Click Content tab ► Library panel ► Content Libraries .
- The Content Library panel appears. You can see the installed standard content in the Content pane.
- Use this Content Library to search for your required standard parts. You can also move the commonly used standard parts to the Favorites pane for easy access.

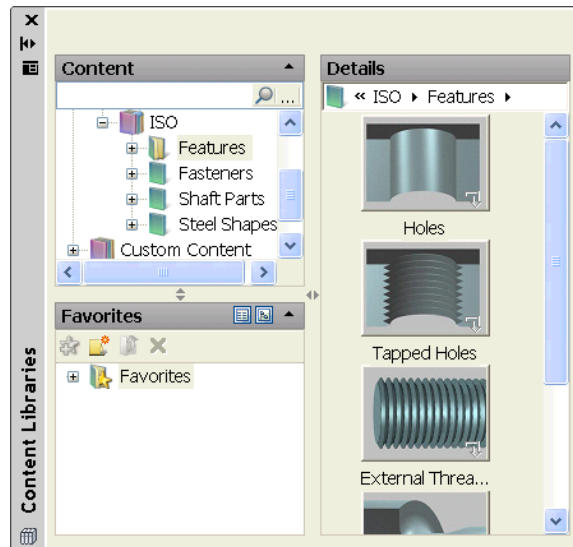

---

**NOTE** If you require standard parts from other manufacturers in your drawings, install the parts libraries from the installation media. It is important to make all required selections during the initial installation of AutoCAD Mechanical.

---

## Content Libraries Navigation

The Content Libraries dialog box includes three panes: Content, Favorites, and Details. You can use any of the following methods to move the selected standard parts to the Favorites list for easy access and reuse in other drawings.

### Method 1:

Drag the part family node from the Content pane to Favorites.

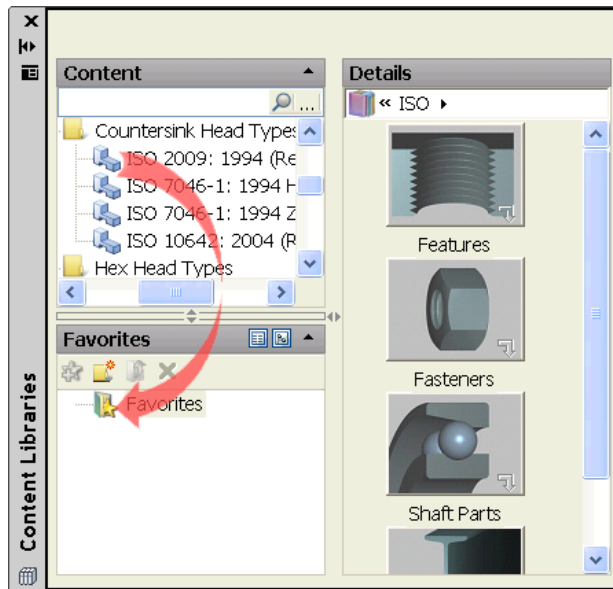

### Method 2:

Right-click the part family node and select Add to Favorites from the context menu.

### View Favorites Lists

When you have a long list of favorites, you can organize the list with the buttons marked 1 and 2 in the following image.

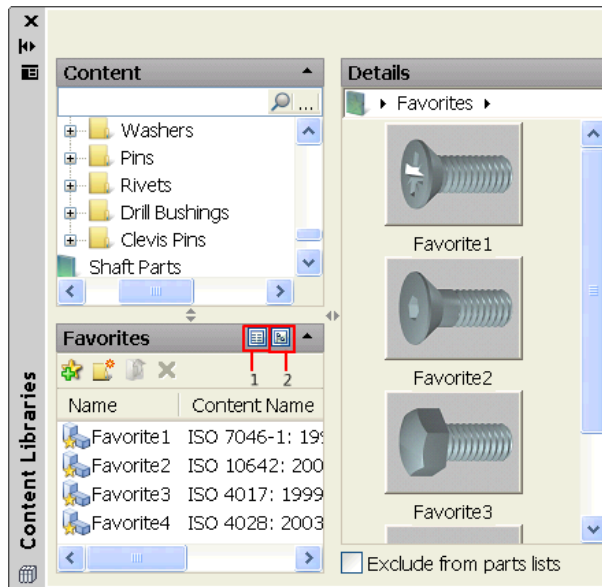

- 1 To show a list of available views in the Favorites panel.
- 2 To show the available views in a tree structure.

### Select a Projected View in Favorites

From the View column, click the current view to open a drop-down list of available views for that part.



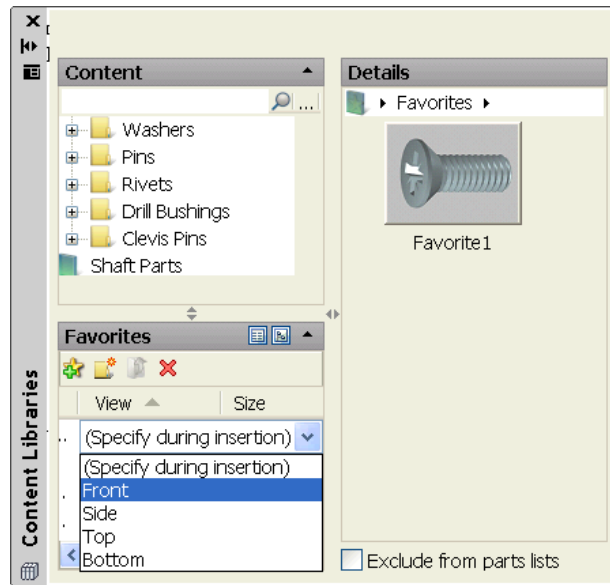

## Resize the Panels

You can resize the panels by dragging the left-right arrows between the panels. You can open and close the panels with the up and down arrows (chevrons) in the upper-right corners of the panels. The following image shows selected standard parts in the Details panel.

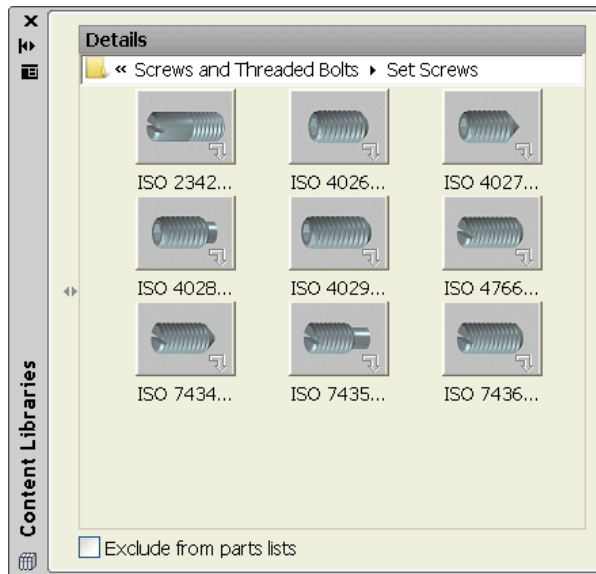

## Insert Screw Components

You can create screw connection assemblies that consist of screws, nuts, washers, and holes with the Screw Connection wizard. When you insert screw connections, you indicate corresponding hole locations for the screws.

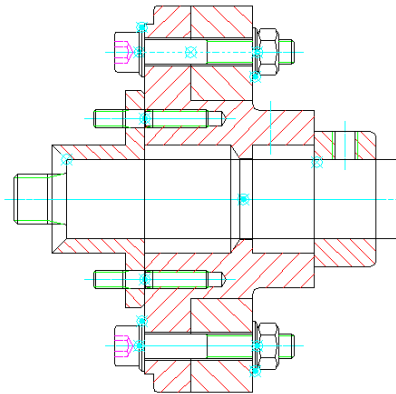



## Insert Screw Components

- 1 Open the *gs\_sealed\_shaft\_assy* drawing in the Getting\_Started folder.

**NOTE** The path to the folder containing Getting\_Started files is:

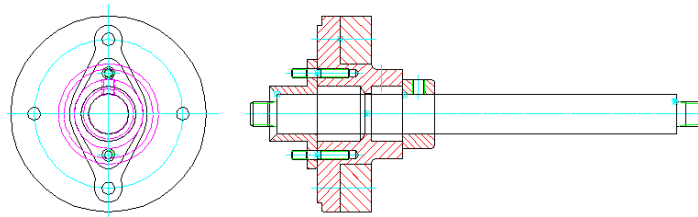
- **Windows Vista®:** *C:\Users\Public\Documents\Autodesk\ACADM 2010\Acadm\Getting\_Started*
- **Windows® XP:** *C:\Documents and Settings\All Users\Documents\Autodesk\ACADM 2010\Acadm\Getting\_Started*



- 2 Click Content tab ➤ Fasteners panel ➤ Screw Connection  . The Screw Connection - Front View dialog box appears.

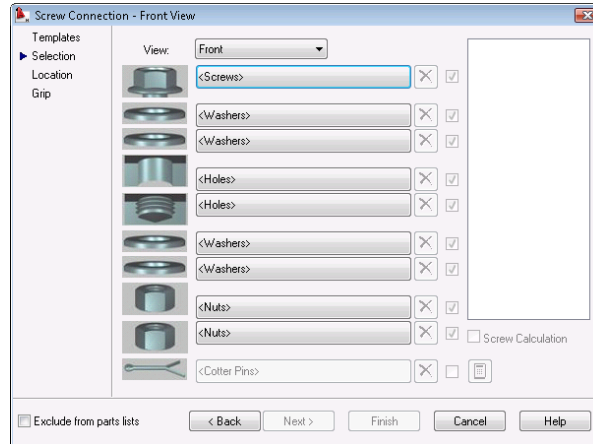

- 3 Click the Back button to select a screw connection template.

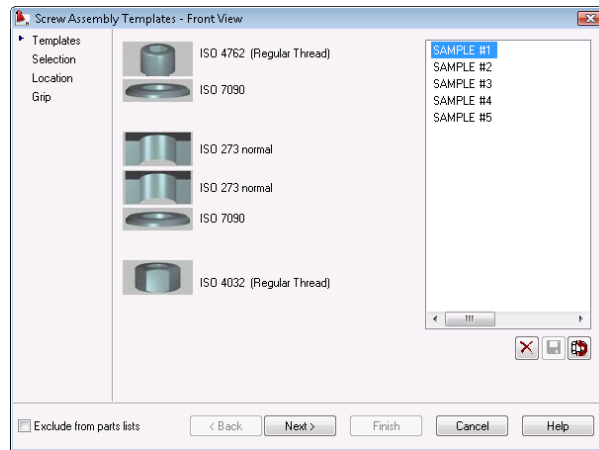

4 Double-click SAMPLE #1 and select the M 8 screw from the list.

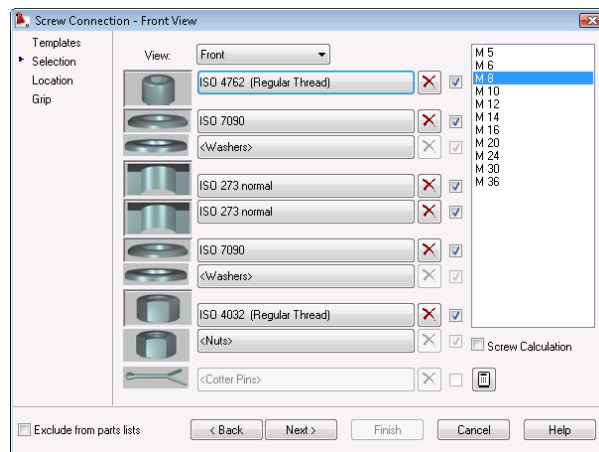

5 Click Next and specify the insertion point of first hole as shown in the following image.

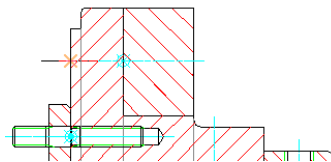

6 Specify the endpoint of first hole as shown in the following image.

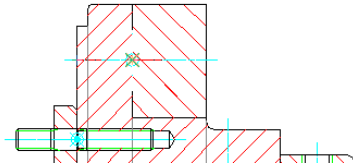

7 Specify the endpoint of second hole as shown in the following image.

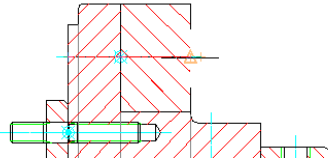

8 Click Next on the Screw Assembly Location - Front View dialog box.

9 Select the Normal representation in the Screw Assembly Grip Representation - Front View dialog box. Click Finish.

The program adds a screw connection to fasten the two plates. Notice that AutoCAD Mechanical automatically removes and cleans up excess materials when you insert the screw components.

---

**NOTE** If there are holes on both the bracket and plate, it is not necessary to select and create holes in the Screw Connection - Front View dialog box.

---

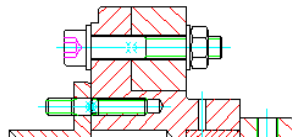

10 Use AMPOWERCOPY to copy the screw connection and place it at the bottom of the assembly.

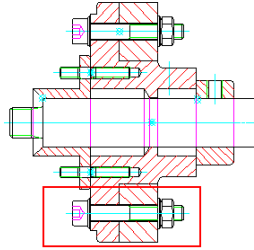

## Insert Fasteners

In the standard part libraries, you can also find the most commonly used fasteners for your assemblies. In this exercise, you insert a cylindrical pin into the pin hole on the bracket.

### Insert a Cylindrical Pin

- 1 Click Content tab ► Fasteners panel ► Cylindrical Pins .
- 2 Select the ISO 2338 pin.
- 3 Select the Front View.
- 4 Specify the insertion point as shown in the following image.

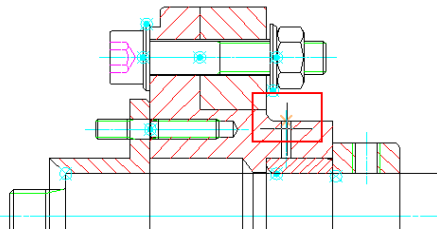

- 5 Enter 270 degrees for its rotation angle.
- 6 Select 3 mm for its diameter.
- 7 Click Finish.
- 8 Drag its length to approximately 12 mm on the bushing.

- 9 Select the standard size - 3m6 x 12-A pin in the Select Part Size dialog box.

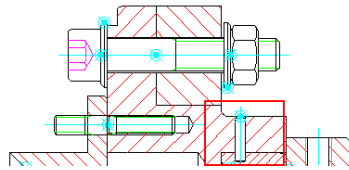

The program inserts the cylindrical pin.

## Edit Standard Parts

All standard parts and features in AutoCAD Mechanical are Power Objects. You can modify them using Power Commands. AutoCAD Mechanical automatically heals and cleans up affected areas after you modify an object with a Power Command.

### Erase the Pin

- 1 Right-click the drawing area to select Power Erase on the context menu.
- 2 Select the Pin to erase.
- 3 Press ENTER.
- 4 Notice that the pin hole on the bushing cleans up automatically and the geometry heals itself.
- 5 Undo the previous step.

---

**NOTE** Do not use the Erase command from AutoCAD® on any Power Object.

---

### Edit the Screw Components

- 1 Double-click the centerline of the screw components.
- 2 Select M 6 in the list.
- 3 Click Finish.  
Notice that all screw components change to the new size.

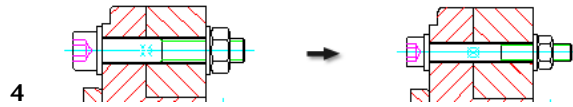

4

Select the other screw connection instances to change to size M 6.

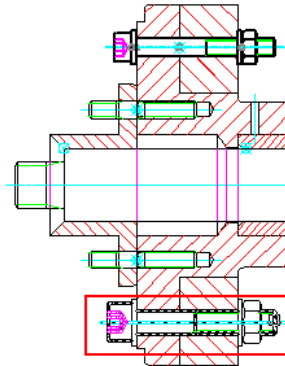

Both screw components change to size M 6.

## Projected Views of Standard Parts

You can generate the projected view of a standard part from its existing view (parent view) using Power View command. Depending on the first-angle or third-angle projection for the drawings your company uses, it prompts you to select a view (top, bottom, front, or side) of the standard part to draw as you generate the projected view.

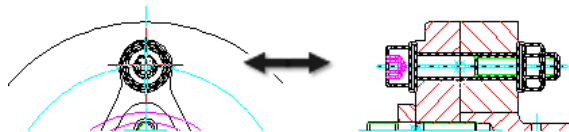

---

**NOTE** The projected views are associative. If there is any change to the parent or child view, the program updates associated views automatically.

---

### Generate the Projected View for Screw Components

- 1 Click Content tab ► Tools panel ► Power View  .



- 2 Select the screw components (Front View) on the right.
- 3 Click Top in AutoCAD Mechanical dialog box.
- 4 Specify the insertion point as shown in the following image.

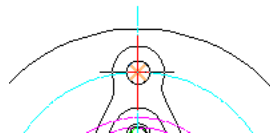

The program creates the top view of screw components.

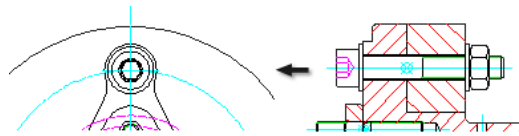

#### Try it: Edit the Screw Components

Double-click the screw component front view and change its size to M 6. Notice that its associated top-view update accordingly.

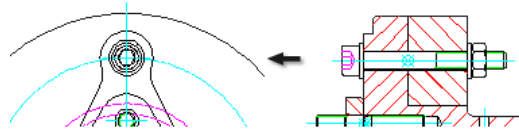

## Change Representations

Your conceptual designs do not need full representations of standard parts. They can use draft representations: symbolic and simplified views. In AutoCAD Mechanical, you can change the representation type by using the Change Representation command.

You can change the representation in the Options dialog box on the AM:Standard Parts tab.

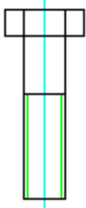
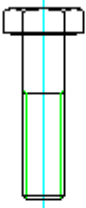
Types	2D Representations
Symbolic	
Simplified	
Standard	

**NOTE** Changing the default setting in the Options dialog box does not affect standard parts already placed in the drawing. It affects only the newly created standard parts.

# Organize Objects with Layers

# 6

With the predefined mechanical layers in AutoCAD® Mechanical, the program automatically organizes the layers for all mechanical parts. Automated organization helps to speed up and simplify your work.

This chapter demonstrates how organizing objects with layers in AutoCAD Mechanical compares to AutoCAD®, and how to convert AutoCAD layers to AutoCAD Mechanical layers.

## Predefined Mechanical Layers

Layers work differently in the AutoCAD Mechanical than they do in AutoCAD.

*What are the differences?*

In AutoCAD, you define layers with properties such as color, linetype, lineweight, and other properties manually in the Layer Properties Manager dialog box. You then create objects on the current layer.

AutoCAD Mechanical does not require you to set up layers for mechanical objects because they are already predefined and fully automated.

When you access a mechanical command, the current layer changes to the layer defined for the objects on which the command executes. The program sets the layer automatically to on or off, locked or unlocked, and plot or non-plottable based on its defined properties.

*What is the benefit of predefined mechanical object properties and layers?*

In mechanical drawings, there are many standard features and parts like through holes, countersink and counterbore holes, screws, washers, nuts, pins, springs, shafts, and mechanical standards for drafting geometries, annotations, and symbols.

AutoCAD Mechanical manages these objects automatically with predefined layers based on the properties of the mechanical objects. Because of this functionality, you spend less time defining layers on your own.

### View the Predefined Layers

All predefined layers begin with the prefix *AM\_*.

1 Click Home tab ► Layers panel ► Mechanical Layer Manager .

2 In the Mechanical Layer Manager dialog box, click  to show the predefined mechanical layers.

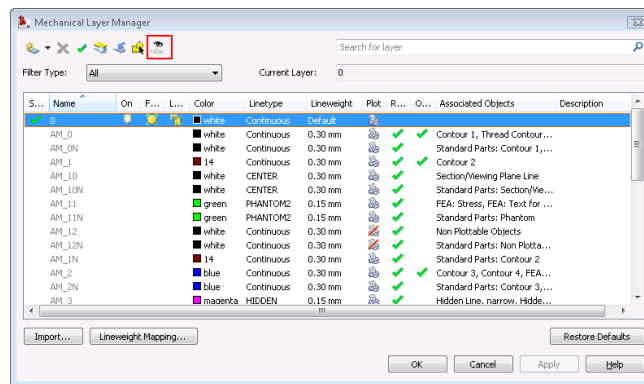

3 In the AutoCAD Mechanical Layers dialog box, click the drop-down arrow in the Filter Type and select Part List. Notice that the layer *AM\_6* associates with Text and the layer *AM\_BOR* associates with Drawing Border.

4 Select other mechanical objects in the Filter Type list. Observe their layers and associated objects.

### Use Predefined Layers

In this exercise, you create a standard part (a screw) and review the predefined layers automatically generated in the drawing.

1 Begin a new drawing based on the *am\_iso* template. AutoCAD always starts with Layer 0 by default. AutoCAD Mechanical starts with Layer *AM\_0*.

- Click Home tab ► Layers panel ► Mechanical Layer Manager  to review the existing layers on the new drawing. Only two layers appear in the Mechanical Layer Manager dialog box.

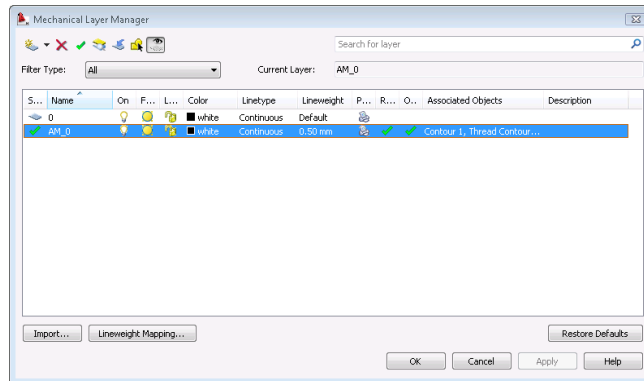

- Click Content tab ► Fasteners panel ► Screws .

- Click Hex Head Types ► ISO 4014 (Regular Thread) ► Front View.

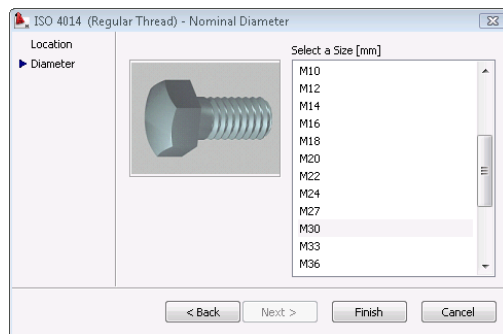

- Insert the screw, size M 30 x 110.



- Click Home tab ► Layers panel ► Mechanical Layer Manager  to review the automatically generated layers for the screw. Notice the

Standard part - screw appears on Layer AM\_ON. See other layers and associated objects used for the screw.

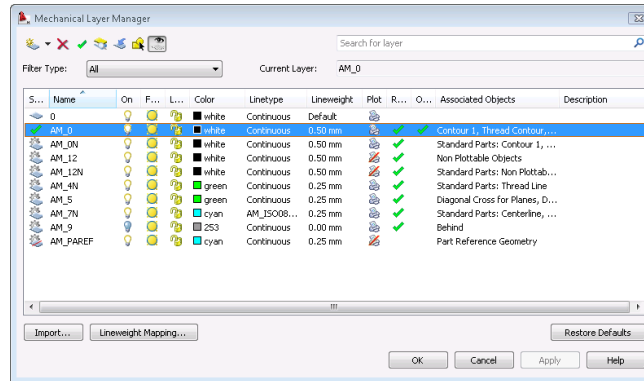

7 Save and close the drawing.

## Mechanical Layer Manager

In AutoCAD Mechanical, you use Mechanical Layer Manager dialog box to organize and manage objects with layers. There are two methods to show this dialog box.

- Method 1:





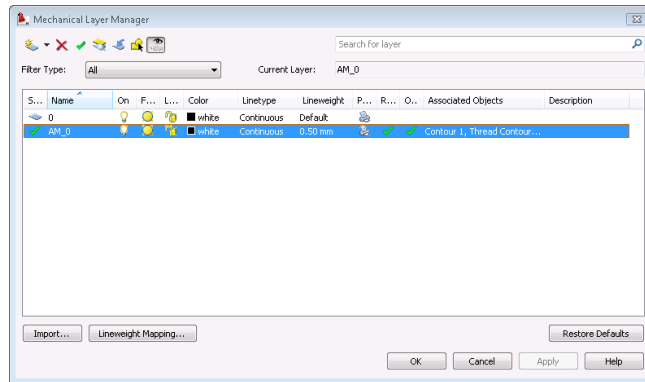

At the Command prompt, enter AMLAYER.

- Method 2:

Click Home tab ► Layers panel ► Mechanical Layer Manager  .



The following table shows the tool buttons and descriptions in the Mechanical Layer Manager dialog box.

Button	Description
 New Layer	Create new layers.
 Delete	Delete layers.
 Set Current	Set a layer to be current.
 Check Layer	Check layers from existing objects.
 Move Into	Move objects into a selected layer.
 Highlight	Highlight the selected layers.
 Show\Hide Layer Definitions	To show or hide layer definitions.

*Can I use the AutoCAD Layer Properties Manager dialog box to manage all layers including the predefined mechanical layers instead of Mechanical Layer Manager dialog box?*

We do not recommend this approach, because no changes you make in the AutoCAD Layer Properties Manager dialog box carry over for mechanical object definitions.

*For legacy AutoCAD drawings in AutoCAD Mechanical, can I change the properties for AutoCAD layers in the Mechanical Layer Manager dialog box?*

Yes. You can change the properties for AutoCAD layers in the Mechanical Layer Manager - AMLAYER dialog box. Your changes overwrite any changes made in the Layer dialog box.

In other words, in the Mechanical Layer Manager dialog box you can control all layers including changes from AutoCAD and AutoCAD Mechanical. You can also clearly define mechanical layers and associated objects.

*Can I rename the AM\_ layers?*

Yes. You can rename these layers according to your company standard naming convention. We recommend that you configure the layers and the properties for all objects in the Object Property Settings dialog box before you start working on any drawings.

## Predefined Object Properties

You can configure the predefined properties of objects you create in AutoCAD Mechanical with the Object Properties dialog box.

- 1 Enter OP (hotkey for Options) at the Command prompt.
- 2 Click the AM:Standards tab.
- 3 Double-click  to open the Standard Settings dialog box.
- 4 Click the Settings button in the Object Properties list.



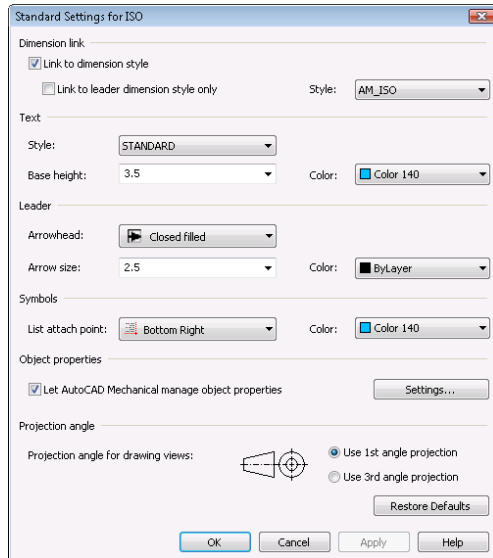

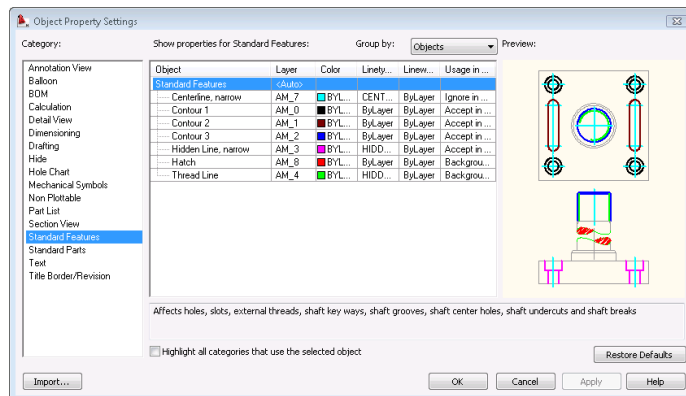

The Object Property Settings dialog box appears, as shown in the following image.



**NOTE** For information on how to configure AutoCAD Mechanical object properties, refer to the Configure Automatic Property Management section in the Configuration and Setup Guide in AutoCAD Mechanical.

## Object Property Settings

When you open AutoCAD drawings in AutoCAD Mechanical, all layers created in AutoCAD automatically appear in the AutoCAD Mechanical Layer dialog box. They remain AutoCAD layers until you change them to AutoCAD Mechanical layers in the Object Property Settings dialog box.

Description	Representative
AutoCAD Layer	
Mechanical Layer	

### Convert AutoCAD layers to Mechanical layers

- 1 Open the *gs\_acad\_layers* drawing from the Getting\_Started folder.

**NOTE** The path to the folder containing Getting\_Started files is:

- **Windows Vista®:** *C:\Users\Public\Documents\Autodesk\ACADM 2010\Acadm\Getting\_Started*
- **Windows® XP:** *C:\Documents and Settings\All Users\Documents\Autodesk\ACADM 2010\Acadm\Getting\_Started*

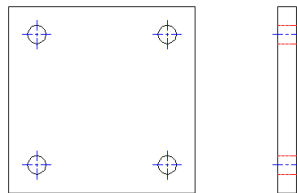

- 2 Click Home tab ► Layers panel ► Mechanical Layer Manager  to open the Mechanical Layer Manager dialog box. Notice that AutoCAD layers appear in it.

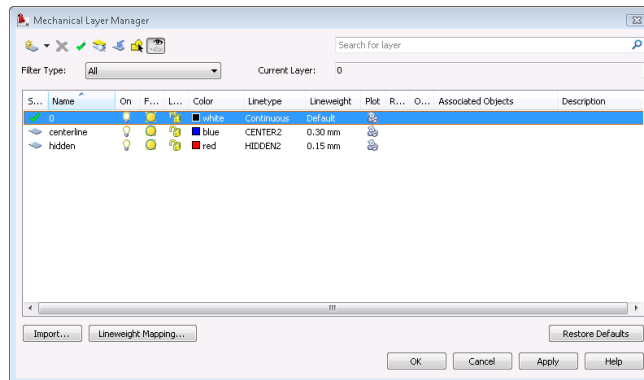

- To convert the AutoCAD layer - Centerline to a mechanical layer, change the layer for Centerline in the category Drafting to Layer - Centerline in the Object Property Settings dialog box.

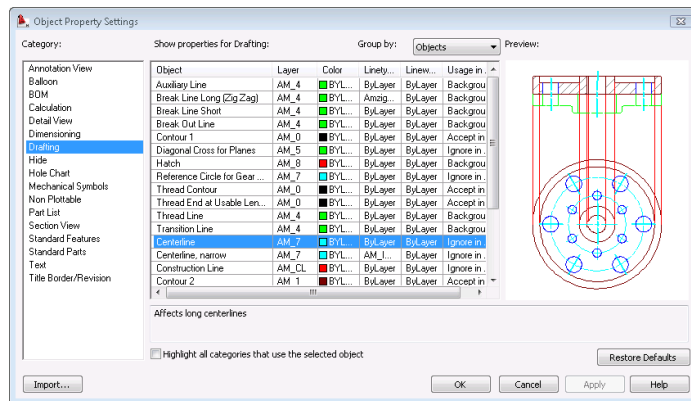

- Click the layer AM\_7 on the object, Centerline. Object Property Settings - Select Layer dialog box displays. Scroll down to the bottom of the list to select the layer centerline.

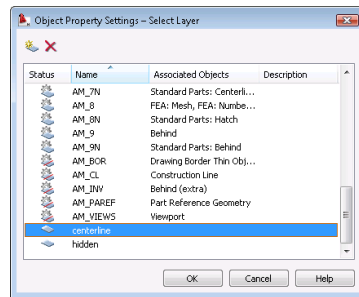

- 5 The Mechanical Layer - Select dialog box appears, informing you that the program is converting an AutoCAD layer to an AutoCAD Mechanical layer.

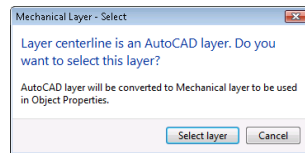

- 6 Click OK three times to close all dialog boxes.
- 7 Next, click Home tab ► Layers panel ► Mechanical Layer Manager



. Notice that the Centerline layer is now an AutoCAD Mechanical layer.

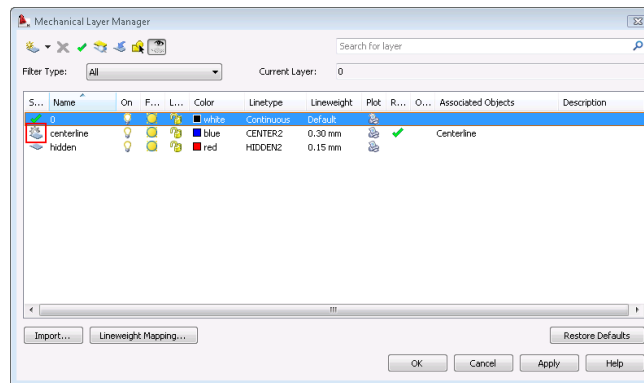

- 8 Next, change the layer for the object - Centerline, narrow in the Standard Features category on the Object Property Settings dialog box to centerline.

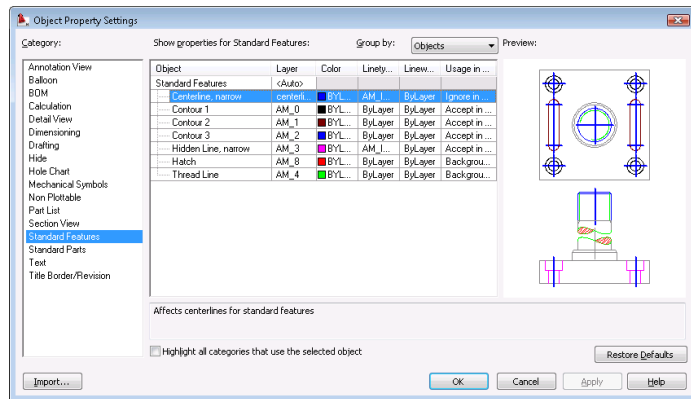

- 9 Click Home tab ► Layers panel ► Mechanical Layer Manager  .  
 Notice the Mechanical layer - centerline is now associated to two mechanical objects: Centerline and Centerline, narrow.

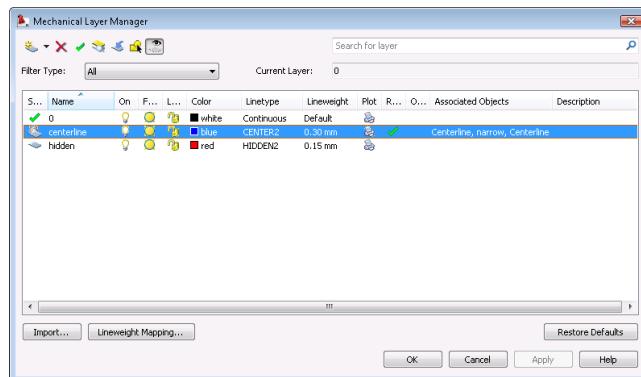

- 10 Click Content tab ► Holes panel ► Through Holes  .
- 11 Select the ISO 273 normal icon, and click Top View to insert an M 30 hole at the center of the plate. Notice the mechanical object, through hole now uses the Layer - centerline for its centerline.

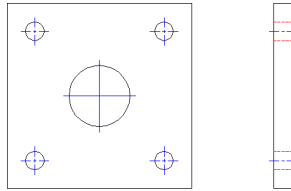

12 Create the front view of the hole using Powerview  .

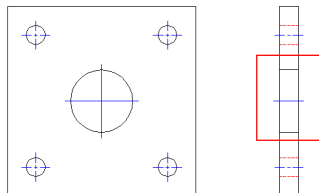

13 Change the Hole - front view to hidden lines type.

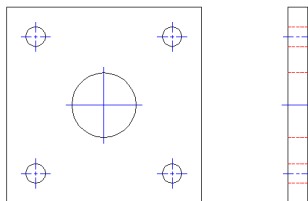

#### Tips

- Use Mechanical Layer Manager dialog box to work with all layers in the drawing instead of the AutoCAD Layer Properties Manager dialog box.
- To ensure layer consistency across all drawings, set up the layers in the Object Property Settings dialog box and save them as templates for reuse.

# Create Hidden Lines

# 7

In assembly or conceptual drawings, it is common to hide background objects to show objects obscured behind connected front objects. AutoCAD® Mechanical represents background objects with hidden lines.

This chapter shows you how to create associative hidden lines by specifying which objects lie in front of others. Any changes to the front or back objects automatically update the associated hidden lines.

## Associative Hidden Lines

In AutoCAD®, converting geometrical lines to hidden lines on mechanical drawings can be a time-consuming task. The process includes breaking each line into multiple segments, changing the linetype to Hidden, and changing the line color properties to the required color. In AutoCAD Mechanical, the process is simpler. You can create hidden lines without breaking the lines into segments, and hidden lines automatically reflect predefined layers and properties.

When working on multiple projects with the same objects and subassemblies, designers frequently have to convert lines between hidden lines and geometrical lines. In AutoCAD Mechanical, the AMSHIDEEDIT command manages that process.

### Create Associative Hidden Lines

Use the AMSHIDE command to create associative hidden lines. After you select foreground objects, overlapped areas of objects that lie behind those objects are drawn as associative hidden lines.

- 1 Open the *gs\_hidden\_lines* drawing from the Getting\_Started folder.

---

**NOTE** The path to the folder containing Getting\_Started files is:

- **Windows Vista®:** *C:\Users\Public\Documents\Autodesk\ACADM 2010\Acadm\Getting\_Started*
  - **Windows® XP:** *C:\Documents and Settings\All Users\Documents\Autodesk\ACADM 2010\Acadm\Getting\_Started*
- 

- 2 Click Home tab ► Draw Tools panel ► Create Hide Situation .
- 3 Select the shaft for the foreground object. Notice that AutoCAD Mechanical automatically places all obscured objects behind the shaft on Level 2 as background objects. In this case, Level 1 refers to the shaft - front object. All other objects behind the shaft are at Level 2.
- 4 There is no limit to the number of levels allowed with the AMSHIDE command. You can place one object or several objects on a level. You can also rename levels, including Level 1, for easy identification and searching.

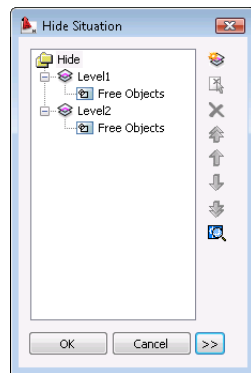

---

**NOTE** If you are working on the mechanical structure environment for structured object, expand the Hide Situation dialog box. Click  to expand the dialog box.

---

- 5 Click OK. Notice that the program hides background objects behind the shaft.



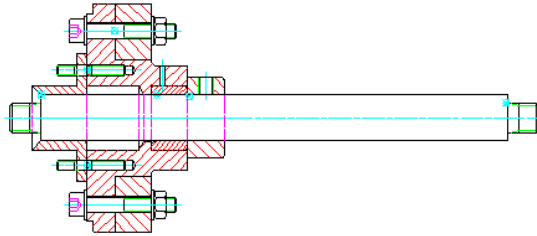

### Try It: Associative Hidden Lines

In this exercise, you move the shaft away from the assembly to see how hidden lines heal and change to solid lines. Move the shaft back into place to see the hidden lines return to the previous state.

Any changes to the foreground or background objects update the resulting hidden lines automatically.

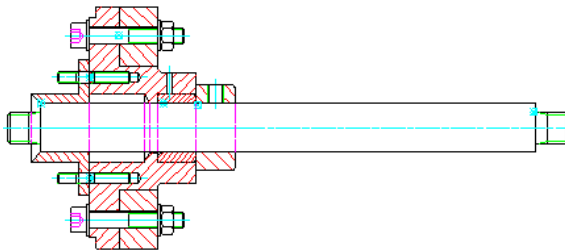
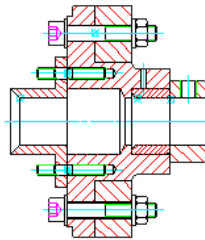

---

**NOTE** You can use `AMSHIDE` command on structured or non-structured drawings. For more information on mechanical structure, refer to Mechanical Help or the Learning Mechanical Structure tutorial.

---

**Tip**

- To revert all hidden lines to geometrical lines for reuse, use the `AMSHIDEEDIT` command to open the Hide Situation dialog box. Remove the elemental geometry from the levels.
- You can also use the `AMSHIDEEDIT` command to modify or update the hide situations in the drawing.

# Reusable Detailing Tools

# 8

In AutoCAD® Mechanical, the drafting tools have intelligence built-in that help you edit the features easily without having to remove and recreate the original features.

This lesson demonstrates some reusable tools such as chamfers, title blocks, and associative detail views.

## Chamfers

You can resize chamfers created in AutoCAD Mechanical using the Chamfer dialog box. Because the chamfer has built-in intelligence, double-click the chamfer to make changes.

### Try It: Edit a chamfer

Open the completed part drawing (the gland) you created. Double-click the chamfer and change its size to 2 mm. See that the dimensions change to the new chamfer size. You can also double-click a fillet to change its size.

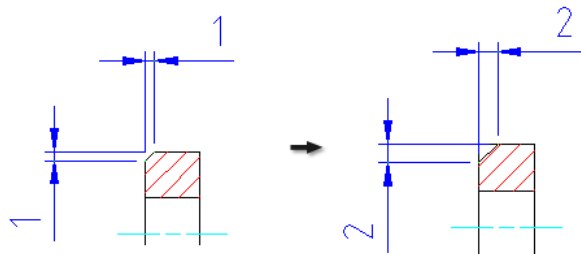



# Title Block

You can scale and center your drawing within the title block using the Title Block (AMTITLE) command. After you place the title block, you can make edits, such as changing the title block style, without erasing and reinserting the title block. Double-click the title block to change its size in the dialog box.

## Insert a Title Block

In this lesson, you place the assembly in the layout, and then insert the title block.

- 1 Open the completed *gs\_hidden\_lines* drawing from the previous lesson.
- 2 Click Annotate tab ► Layout panel ► Viewport/ Scale Area  .
- 3 Select the entire drawing.
- 4 Select the check box for Automatic view creation in Layout1.
- 5 Click OK and place the viewport on the layout.
- 6 Click Annotate tab ► Layout panel ► Title Border  .
- 7 In the Drawing Borders with Title Block dialog box, select A2 (420x594mm) in the paper format list. Click OK.
- 8 Click Close in the Page Setup Manager dialog box.
- 9 Locate and place the title block in Layout1.
- 10 Enter drawing information in the Change Title Block Entry dialog box. Click OK.
- 11 Select the viewport outline and press Enter when the program prompts for a new location for the object.

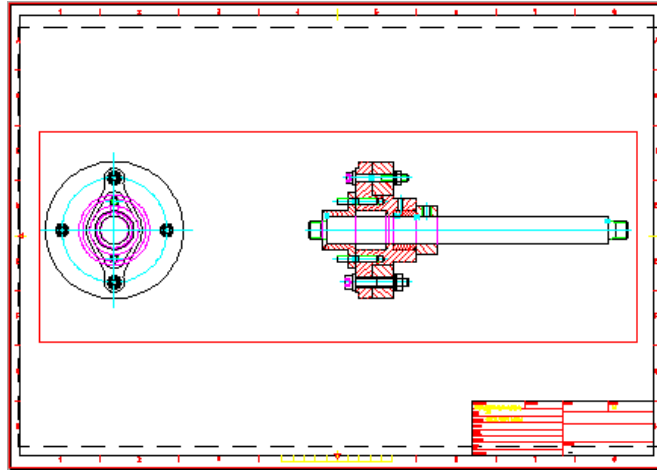

---

**NOTE** Use the Viewport/Scale Area command to control the length and text scaling when creating viewports. For more details, refer to the AutoCAD Mechanical Help.

---

## Associative Detail View

Detail views show an enlarged area of geometry or a dimensioned part that is not clearly visible in the original view. Use the Detail command to create linked views at different scales and place them in model space or in the layout. The geometry in the detail view is associative to the original view. If you change the original view, the program updates the associative detail view. If you change the associative detail view, the program updates the original view.

In the following image, a detail view shows its geometry two times larger than its original view. Continuing from the previous title block insertion, use the AMDETAIL command to create a detail view and place it on the Layout tab.

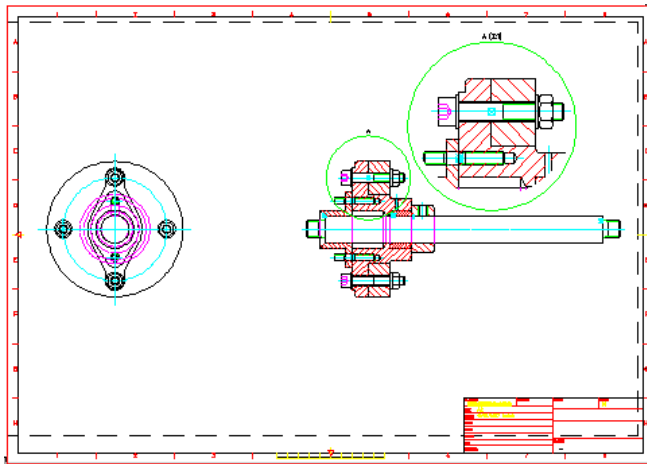

### Create a Detail View

- 1 Click Home tab ► Draw Tools panel ► Detail View .
- 2 Enclose the screw connection as shown in the following image.

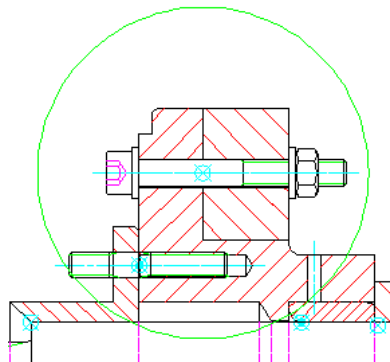

- 3 Switch to the viewport of the original layout in the Detail view list to place the detail in the layout tab.

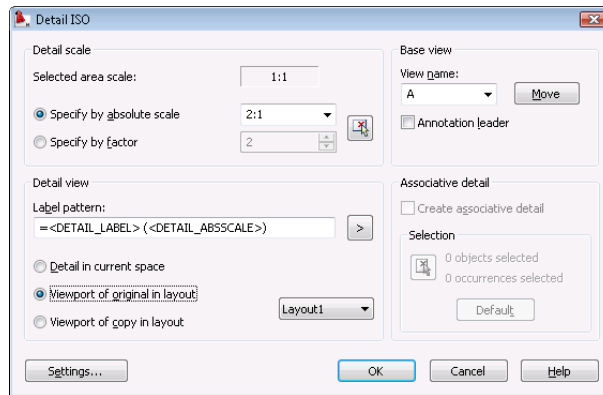

- 4 Click the Settings button in the Detail ISO dialog box. Select the Show view border check box.

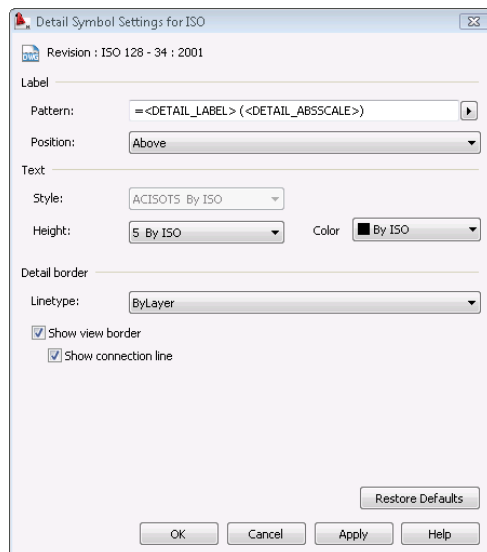

- 5 Click OK and place the enlarged detail view on the drawing.

### Try It: Edit a Detail View

Double-click the centerline of the screw connection and change its size from M 8 to M 6. Notice that the associated detail view changes accordingly.

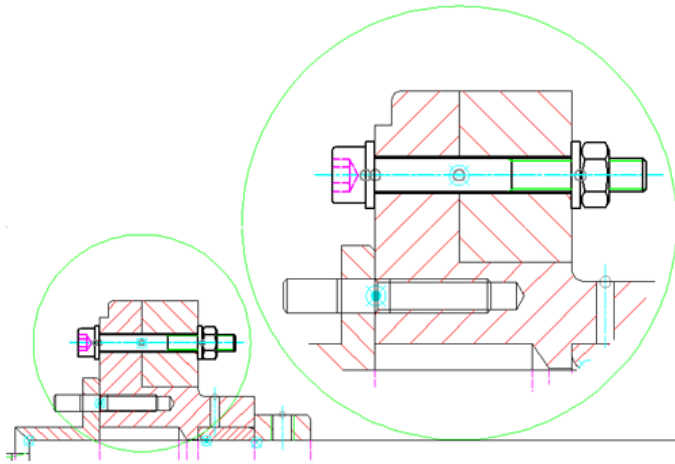

**Try It: Dimension a Detail View**

Use the Power Dimension command (AMPOWERDIM) to add dimensions in the detail view.

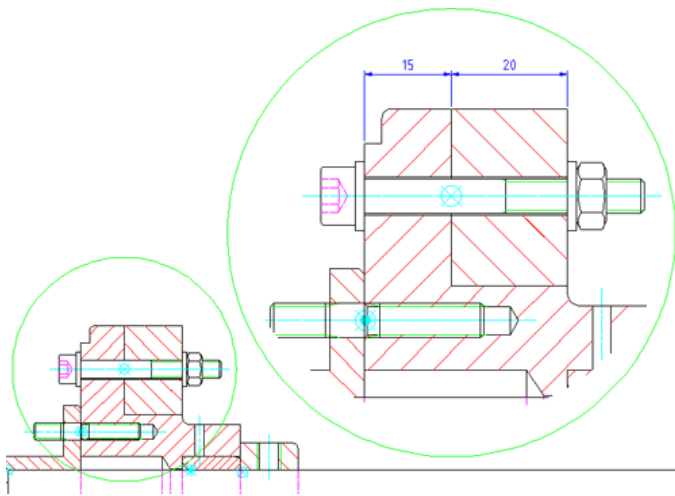



# Power Dimensions

# 9

Unlike AutoCAD®, AutoCAD® Mechanical does not use several dimension commands to create linear, angular, baseline, and chain dimensions. In AutoCAD Mechanical, the power dimension command, AMPOWERDIM, saves you time in creating multiple dimension types on your drawings.

This lesson describes how to use the Power Dimensioning and automatic dimensioning tools to add dimensions on your drawings. It also shows you how to edit dimensions quickly with a set of editing tools.

## Create Mechanical Dimensions

You create dimensions on a drawing to communicate the required sizes of parts to the production team for fabrication purposes.

Use the Power Dimension command to create horizontal, vertical, aligned, rotated, angular, radial, baseline, and chain dimensions. Power Dimensions give you the flexibility to define the appearance and content of the dimensions.

You can create dimensions in model space or layout. Power Dimensions automatically adjust based on the scale factors of the scaled area in model space. In the layout, dimensions added automatically based on the points or geometry selected.

### Add Dimensions by using Power Dimensioning

In the following image shows the completed dimensioning on the two views of a gland.

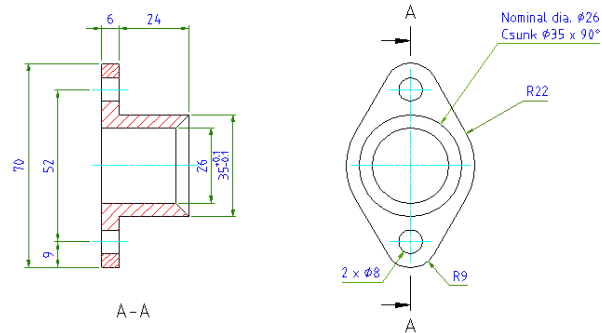

- 1 Open the *gs\_dimensions* drawing in the Getting\_Started folder.

---

**NOTE** The path to the folder containing Getting\_Started files is;

- **Windows Vista®:** *C:\Users\Public\Documents\Autodesk\ACADM 2010\Acadm\Getting\_Started*
  - **Windows® XP:** *C:\Documents and Settings\All Users\Documents\Autodesk\ACADM 2010\Acadm\Getting\_Started*
- 

- 2 Click Annotate tab ► Dimension panel ► Power Dimension .
- 3 Insert the 6-mm dimension for the flange of the part.
- 4 Locate the dimension line location. Click at the location when the dimension line appears in red. This location is the preset dimension line location from the geometry contour.

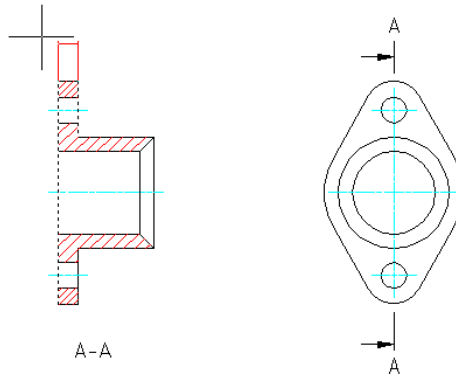

- 5 The Power Dimensioning dialog box appears showing the dimension value. Click OK.

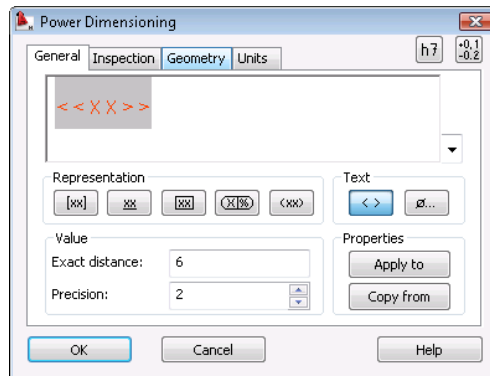

- 6 **NOTE** By default, the Power Dimensioning dialog box appears for the first set of dimensions and not for subsequent dimensions when working on the Power Dimension. To change this behavior, go to Options ► AM:Standards ► and double-click the Dimension in the Standard elements list.

- 7 Enter C (for Chain) in the command line. Insert the 24-mm dimension. Notice you are still in the Power Dimensioning command.

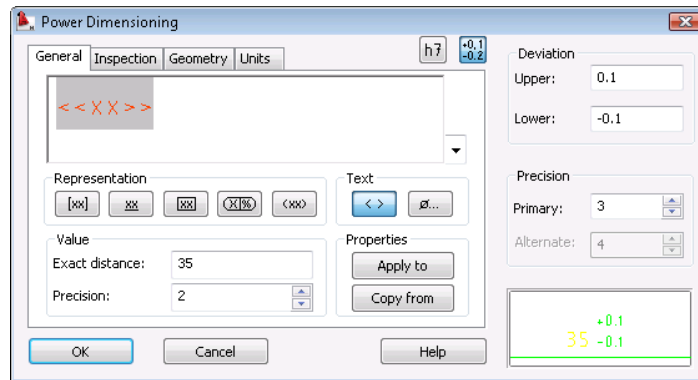



---

**NOTE** When adding the dimension, you can set its options, add tolerances, and fits to the dimensions.

---

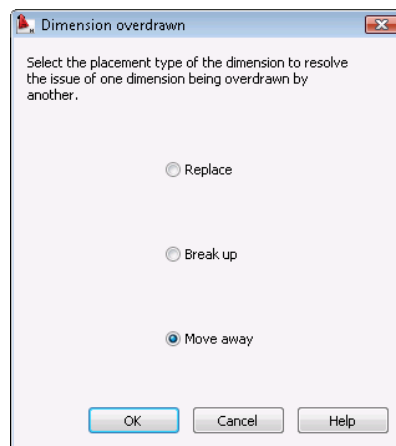
- 8 Press ENTER twice to reactivate the Power Dimensioning command to create the 26-mm dimension.
- 9 Enter S to select the line for the 35-mm dimension. Enter O to open the Power Dimensioning dialog box and create its tolerance.
- 10 If the 70-mm dimension overlaps the 52-mm dimension, a Dimension Overdrawn dialog box appears. You can move the overlapping dimension away from the other automatically.



- 11 Create all dimensions for the front view.

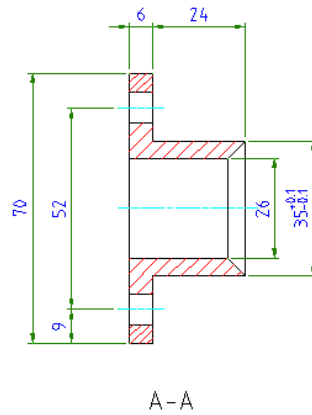

12 Continue to add the radial dimensions for the side view.

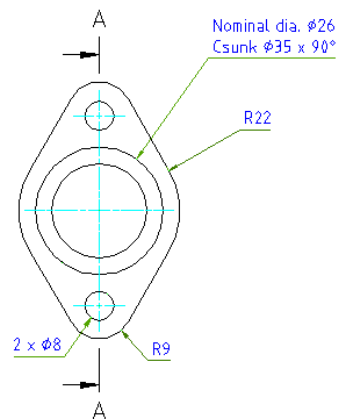



---

**NOTE** When placing dimensions, you can switch between radial dimensions and diameter dimensions.

---

## Multiple Dimensions

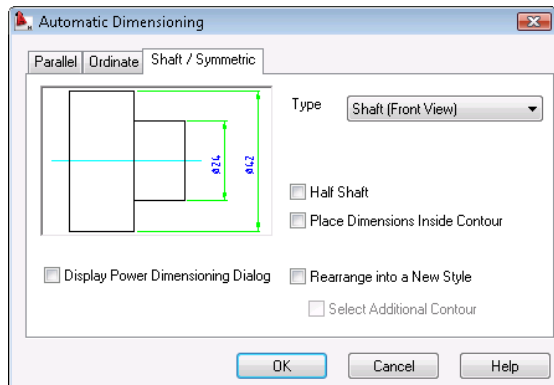
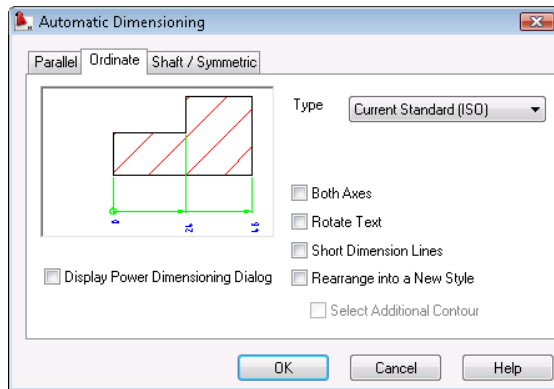
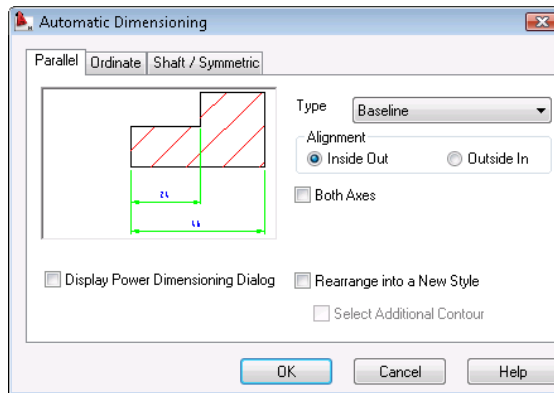
It is often necessary to create ordinate dimensions on semiconductor or automation drawings. In AutoCAD Mechanical, you can create a group of parallel, ordinate, shaft, and symmetrical dimensions all at the same time by using the Multiple dimensioning command.



Filtering is enabled automatically to prevent you from dimensioning hidden lines, auxiliary lines, text, phantom lines, section lines, hatches, or other dimension lines.

Multiple dimensioning commands use the current drawing standard and drawing scale. The program places them on layer AM\_5.

### Try It: Create Multiple Dimensions

In the following exercise, you specify the datum point at the lower left corner of the flange and create automatic dimensions along its x-y axis. Notice that the program ignores hatching lines when dimensioning.

Click Annotate tab ► Dimension panel ► Multiple Dimension . Select the Ordinate tab, and select the check boxes for Both Axes and Rotate Text. Generate the dimensions as shown in the following illustration.

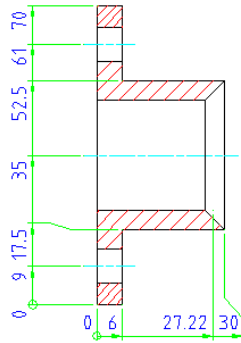

## Edit Dimensions

To open the Power Dimensioning or Automatic Dimensioning dialog boxes for editing, double-click the existing dimensions. Dimensions change instantly when you select new options or enter new parameters in these dialog boxes.

You can break, rearrange, stretch, and join dimensions with dimension editing tools in AutoCAD Mechanical.

### Try It: Edit Dimensions

Edit several dimensions at your own pace. From the Annotate menu, click Edit Dimensions, and select the editing tools shown in the following image.

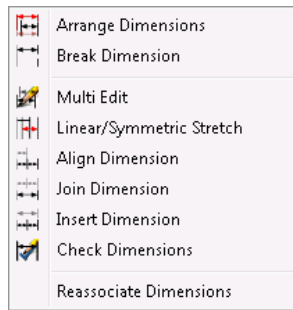



# Add Part Lists and Balloons

# 10

Adding part lists and balloons in AutoCAD® Mechanical is easier than the manual method in AutoCAD®. You can also ensure an accurate count of item quantities as you add or remove objects in an assembly drawing.

This lesson describes the role of part references for objects and how they relate to a bill of materials (BOM) in an assembly drawing. It also shows you how to create and edit a bill of materials (BOM), and to add a part list and balloons to a drawing.

## Create Part References

In this lesson, you identify and itemize each part or component with attributes in the part reference.

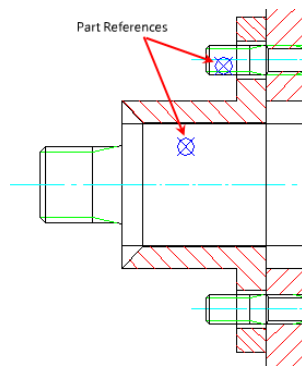

All standard parts including screws, nuts, steel shapes, and others have part references automatically generated from the manufacturer catalogs. See the following illustration. Notice the representation of nodes used for standard parts is different from the designed components as shown previously.

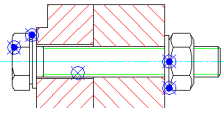

The part reference contains component properties such as material, note, vendor, measurement, and units. You can also add and include the component properties from the bill of materials. Click the Settings button on the Part Reference dialog box.

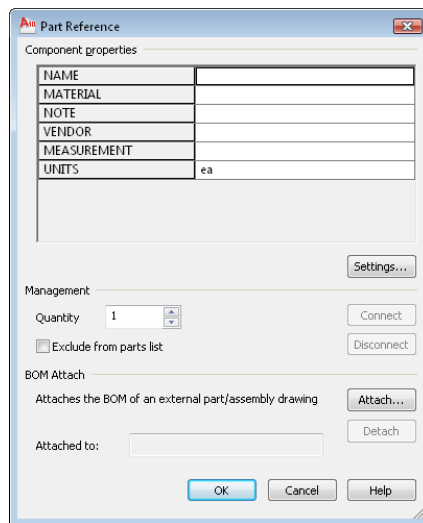

The program captures component properties to the bill of materials (BOM) for use in part lists and balloons.

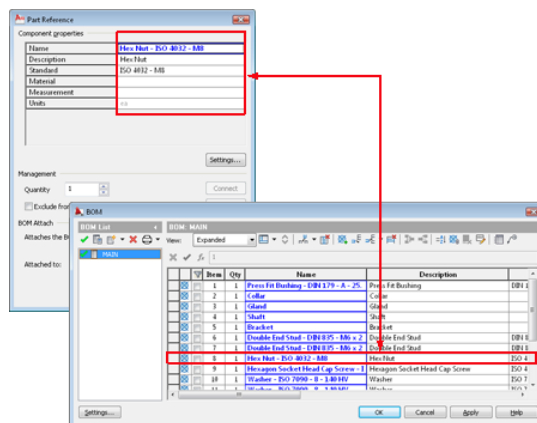

---

**NOTE** If you add or remove part references, the quantity value for the changed component updates automatically in the bill of materials.

---

### Try It: Create a part reference

Create a part reference for a component on your own. From the Annotate menu, click Part Reference, and then click the component to locate the node and open the Part Reference dialog box. Enter the component properties and click OK.

## About Bills of Materials (BOMs)

The BOM is the database of all parts and subassembly components in the assembly. It captures all part references and information for parts you use in an assembly drawing. You can view and edit the BOM information in the BOM dialog box.

You can add, delete, and edit component properties in the BOM dialog box. A drawing file can have more than one BOM. You can add or remove columns or rows of information, change the order of the information shown in the dialog box (like in an Excel spreadsheet), and insert part lists or balloons into the drawing. See the BOM dialog box in the following image.

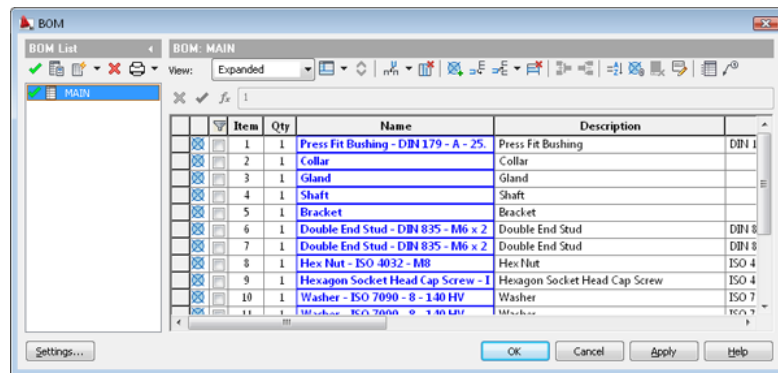

### BOM Settings

To manage the BOM settings, open the Options dialog box. Double-click BOM in the Standard elements list in the right pane.

- 1 Right-click an empty place on the drawing area, and on the context menu click Options ➤ AM:Standards tab.

- 2 In the pane on the right, in the Standard elements list, Double-click BOM.  
A dialog box with BOM settings for the active standard displays.

In the BOM Settings dialog box, you can add component properties from the available component properties list to the four tabs: Component Properties, BOM, Parts List, and Balloon. Select an entire row, and then click Add.

You can also add custom component properties to the Available component properties list. To add a component property, double-click the last row and enter your custom property.

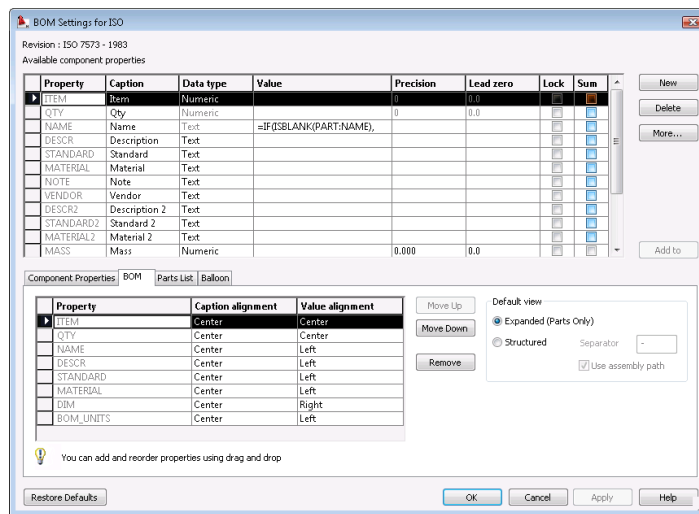

## Create Balloons

You use balloons in mechanical drawing to itemize the parts in an assembly.

### Create Balloons

- 1 Open the *gs\_balloons* drawing from the Getting\_Started folder.

---

**NOTE** The path to the folder containing Getting\_Started files is:

- **Windows Vista®:** *C:\Users\Public\Documents\Autodesk\ACADM 2010\Acadm\Getting\_Started*
  - **Windows® XP:** *C:\Documents and Settings\All Users\Documents\Autodesk\ACADM 2010\Acadm\Getting\_Started*
- 

- 2 Click Annotate tab ► Balloon panel ► Balloons  .
- 3 Enter T (auto) to create balloons automatically for the selected part references.
- 4 Enclose the whole assembly - front view. Make sure that you do not miss any part references.
- 5 Press ENTER to place the balloons.

---

**NOTE** Press F8 to turn off the orthogonal mode for easy placement of balloons.

---

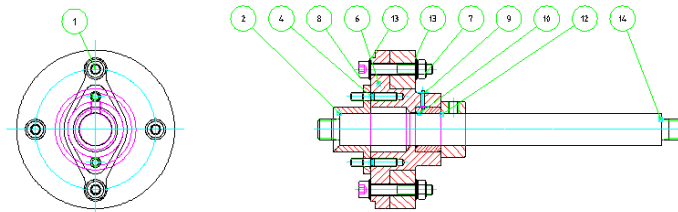

---

**NOTE** Use the option -reorganize in the AMBALLOON command to rearrange balloons into a straight line.

---

## Create Parts Lists

You create a part list to show a list of detail information for parts used in an assembly drawing.

### Create a Parts List

- 1 Continue from the previous exercise.
- 2 Click Annotate tab ► Table panel ► Parts List  .
- 3 Press ENTER to create a parts list from the main BOM.
- 4 Click OK and place the parts list at the bottom right of the title block.

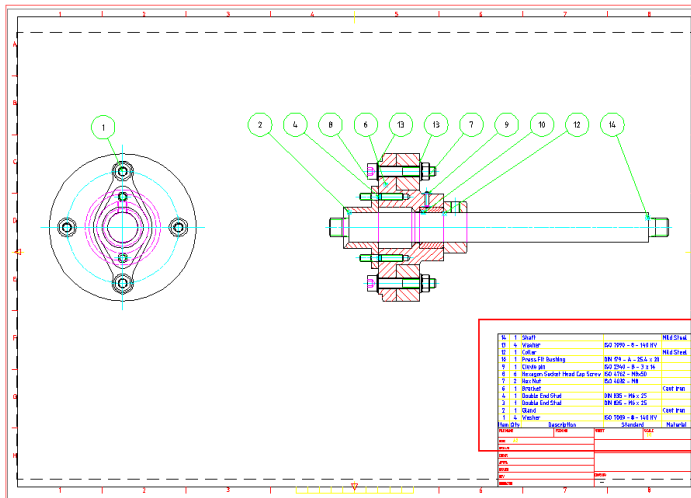

# International Drafting Standards

# 11

Setting a standard based on industry standards or a custom company standard helps to maintain a common form of communication for consistent production results. AutoCAD® Mechanical supports ANSI, BSI, CSN, DIN, GB, GOST, ISO, and JIS industry standards. You can also create a custom standard based on one of the industry standards and change some or all the settings according to your company standard.

In this lesson, you use the annotating tools in AutoCAD Mechanical to create standards-based tolerances, fits, datum identifiers, feature control frames, surface texture symbols, welding symbols, and leader notes to meet these standards.

## Set Drafting Standards

In mechanical drawings, the standard controls all geometry, symbols, and text sizes. You select an industry standard, or a custom company standard, when you start working on a drawing. You can also import a standard template from your project team or another company.

To set the standard, activate or modify a standard in the standards list of the AM:Standards tab in the Options dialog box. You can also edit multiple elements to match the settings specific to your company or industry standard in the right pane of the AM:Standards tab. The active standard appears with an open book icon at its left. See the following image.

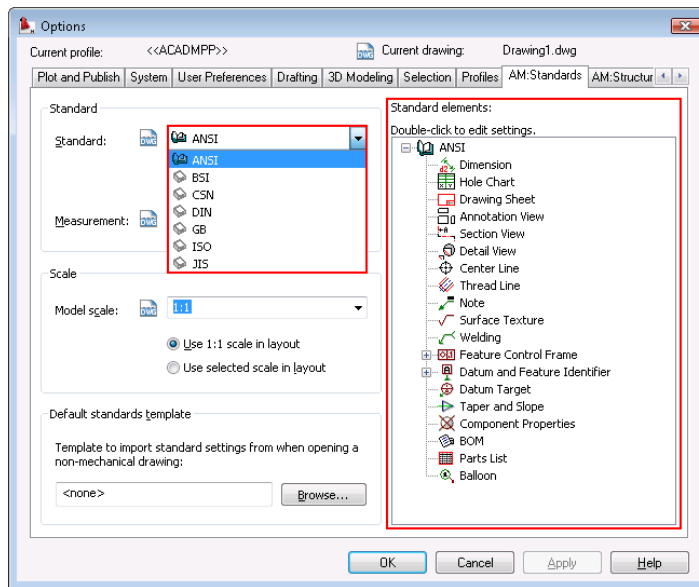

## Create Custom Standards

In the Options dialog box, double-click the active standard and type a new standard name, for example “Company Standard.”

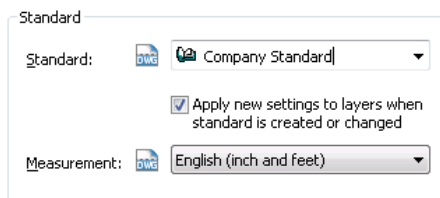

Press ENTER. The Selection dialog box appears, enabling you to select a base standard. Select a base standard from the drop-down list and Click OK.

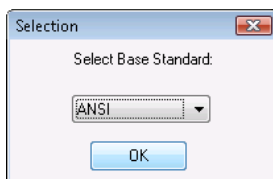

The program creates a custom standard, *Company Standard*.



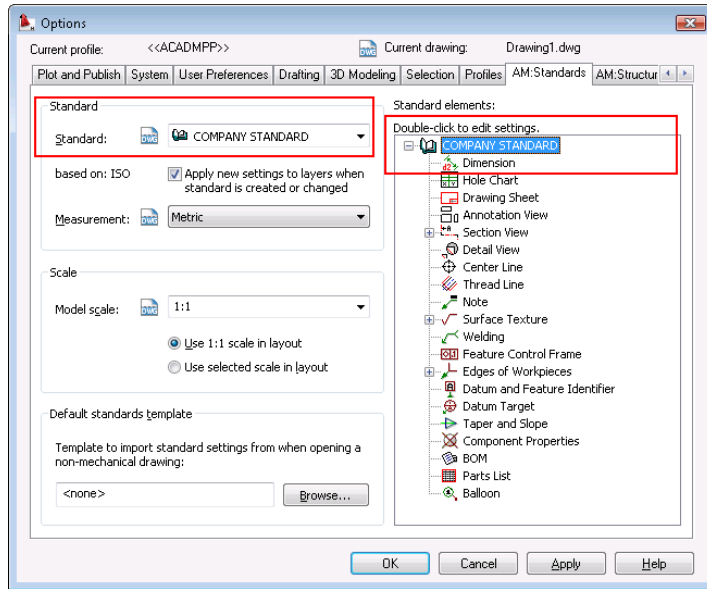

### Best Practice

Set up a default template file with your selected standard to start every new drawings and make it available to everyone in the project team. By doing so, you save time configuring your requirements and ensure consistency with all team members using the company standards.

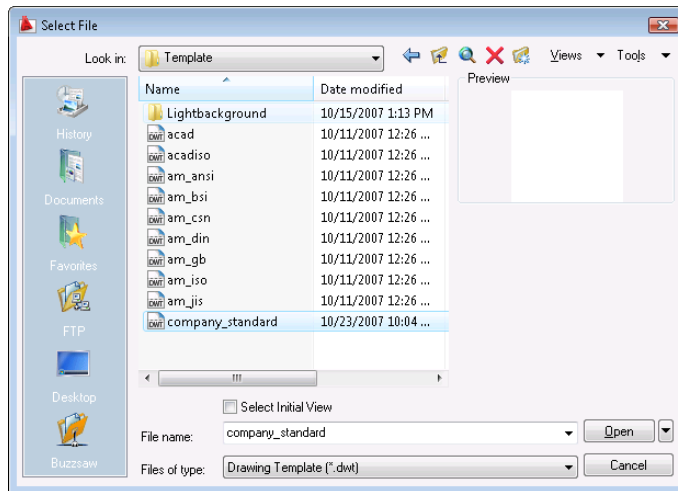

Save your default standards template in DWT format. To use this template for non-AutoCAD Mechanical drawings, import this template into the drawings when you open them.

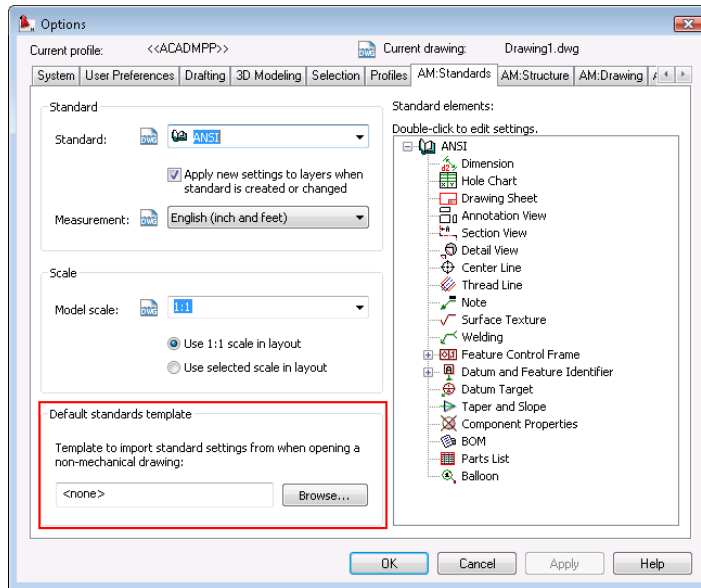

## Scale for Text and Symbols

For many large components or assemblies, it is necessary to scale down text and symbols to fit them on standard paper sizes (A4, A3, A2, A1, or A0 size). Annotations, including dimensions, symbols, and notes, can become illegible when you view them in the model space. This session shows how you can set the scale for the text and symbols.

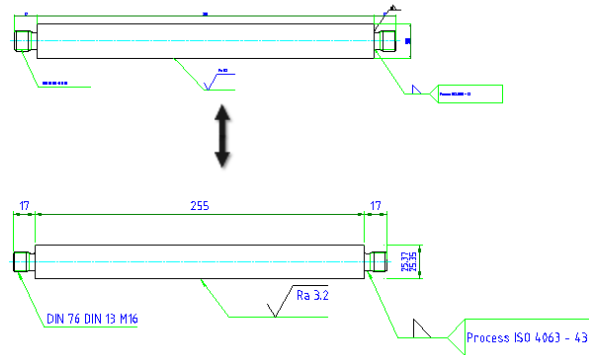

To set the size of symbols and text to the required sizes for viewing and printing purposes, set the scale factor in the Model scale list in the Options dialog box.

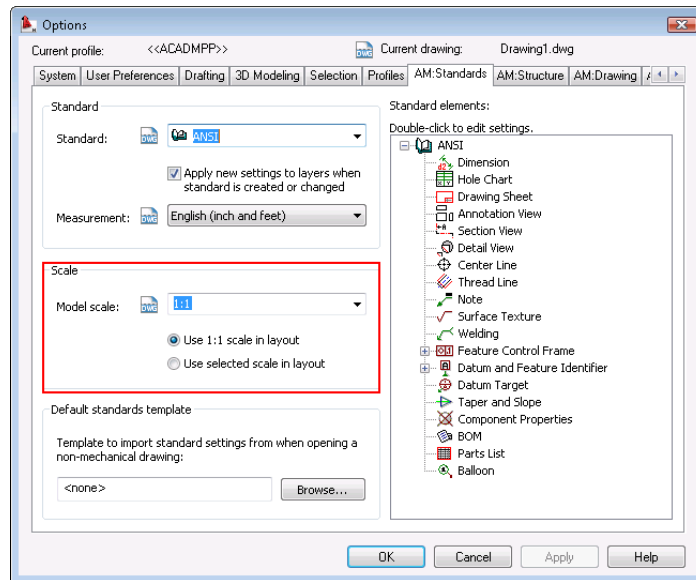

---

**NOTE** When you change the model scale factor to 1:2, the annotations are automatically two times larger than they are at scale factor 1:1.

---

## Standard-based Annotations

In the following exercise, you create the symbols for the front view of a shaft used in a sealed shaft assembly based on the ISO standard with metric measurements.



The following image shows a detailed shaft with the annotations.

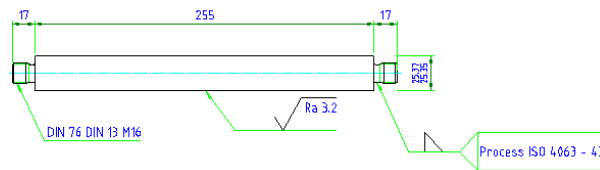

### Try It: Standard-based Annotations

Open the *gs\_shaft* drawing in the *Getting\_Started* folder.

---

**NOTE** The path to the folder containing *Getting\_Started* files is:

- **Windows Vista®:** *C:\Users\Public\Documents\Autodesk\ACADM 2010\Acadm\Getting\_Started*
- **Windows® XP:** *C:\Documents and Settings\All Users\Documents\Autodesk\ACADM 2010\Acadm\Getting\_Started*

---

From the *Annotate* tab, use the annotating tools on the *Symbol* panel to add the feature control frame, tolerance, surface texture, and welding symbol as shown in the previous image.

Change the scale factor in the model scale list, and then rescale all the symbols and dimensions to view the new size.

Add a custom standard in the *AM:Standards* tab of the *Options* dialog box. Modify some of the elements such as the color of the arrow for welding symbols. You can also save the current settings to a default template, a *DWT* file, for reuse.

# Index

## A

additional resources 1  
associative hatch 20  
associative hidden lines 57  
automatic dimensioning 71

## B

balloons 78  
bill of materials 77  
bom 77

## C

center line 23  
center line pattern 23  
chamfer 61  
construction line 13  
Convert AutoCAD Layers to Mechanical  
Layers 52  
countersink hole 18  
custom standard 82

## D

detail view 63  
dimensions 67  
drafting standard 81  
drawing file type 9

## F

fastener 40

## H

hatch 20  
hidden lines 57  
hole 14

## M

mechanical dimensions 67  
modify dimensions 73

## O

object properties 50

## P

part list 79  
part reference 75  
power commands 27  
predefined layers 45  
projected view 42

## R

rectangle 22  
resources  
additional 1

## S

screw connections 36  
section line 24  
standard for symbols 81  
standard parts 31  
standard parts library 31

## T

title block 62

## U

user interface 3

**W**

workspace 5