

# Global Governance Voice



# CONNECTING ASIA'S ECONOMIES

THE LEADING MIDSHORE BUSINESS AND FINANCIAL CENTRE



Labuan International Business and Financial Centre (Labuan IBFC), located off the North West coast of Borneo, offers global investors and businesses the benefits of being in a well-regulated midshore jurisdiction that provides fiscal, legal and currency neutrality, in addition to being an ideal location for cost-efficient substance creation.

Labuan IBFC is a wholesale financial, risk and wealth management intermediation centre that also boasts a wide range of business structures including solutions for fintech or digital businesses. It is also home to the world's first sukuk and is acknowledged as an Islamic financial hub.

Well-supported by a robust, internationally recognised yet business-friendly legal framework, Labuan IBFC operates within comprehensive legal provisions and guidelines, enforced by a single regulator, Labuan Financial Services Authority – a statutory body under the Ministry of Finance, Malaysia.



# CONTENTS

- 4 Chief Executive's Message
- 6 How Three South African State-owned Companies have Responded to COVID-19
- 12 Beyond COVID-19: Taking the Long View Board & Investor Perspectives
- 17 COVID-19 Crisis: E-Government Platform as Rescue Vessel
- 20 Brought to Light
- 24 Taxation of the Platform-based Economy
- 30 Do Directors Prepare Well for Board Meetings?
- 34 To Whom Does the Company Secretary Owe a Duty of Care?
- 39 Breathing Space
- 42 Independent Directorship: Have you Got What it Takes?
- 47 Member Update: The Governance Professionals of Canada
- 48 Member Update: The Society for Corporate Governance
- 50 Member Update: Hong Kong Institute of Chartered Secretaries

## Full Members



## Affiliate Members



## August 2020

The Global Governance Voice, the magazine of the Corporate Secretaries International Association Limited (CSIA), is published on behalf of the CSIA by Ninehills Media Ltd and is sent to member countries and globally to selected senior executives in the public and private sectors. Views expressed are not necessarily the views of the CSIA or Ninehills Media Ltd.

Any views or comments are for reference only and do not constitute investment or legal advice. No part of this magazine may be reproduced without the permission of the publisher or the CSIA.

**Production by:**  
 Ninehills Media Limited  
 Level 12, Infinitus Plaza,  
 199 Des Voeux Road,  
 Sheung Wan, Hong Kong  
 Tel: (852) 3796 3060  
 Fax: (852) 3020 7442  
 Email: enquiries@ninehillsmidia.com  
 Website: www.ninehillsmidia.com



**Advertising sales enquiries:**  
 Email: enquiries@ninehillsmidia.com

**Artwork & Layout:**  
 Portia Le

**Cover images:**  
 andreypopov



**For all enquiries:**  
 CSIA  
 Zahra Cassim, CEO  
 Email: ceo@csiaorg.com

Corporate Secretaries International Association Limited  
 3F, Hong Kong Diamond Exchange Building,  
 8 Duddell Street, Central, Hong Kong  
 Internet: www.csiaorg.com  
 © Copyright reserved

# CHIEF EXECUTIVE'S MESSAGE

**Zahra Cassim**  
ceo@csiaorg.com



As the world settles in to the new normal created by the COVID-19 pandemic, there is also an increasing realisation that there is a need to re-align thought processes to accommodate the transformation of the global economy and find a balance between the negative and positive consequences of the changes that will impact on the world population, the global economy and ultimately the planet.

It is inevitable that some companies will not survive the economic devastation brought about by the pandemic and, in many cases, it highlights the inability of companies to adapt due to a focus on short-term value maximisation rather than sustainability. Even in companies that are resilient enough to survive, the leadership faces the dilemma of finding a balance between protecting the financial performance of the company while also protecting the interests of their employees, stakeholders and the broader community.

CSIA conducted interviews with governance professionals in CSIA member countries to elicit their views on how companies in their jurisdiction are managing this dilemma

and to share their advice on ethical leadership in a COVID-19 environment. Visit our website and social media platforms to watch the videos and find out more about how ethical leadership is being practised in different countries.

It has been a busy period for CSIA as we have been in the process of re-designing the association's website and social media platforms to reflect a new fresh image to celebrate our 10th year of existence and I am delighted to announce that the website has gone live this month! We are planning to keep you updated with information on governance practices from across the world in the form of events (hosted by CSIA as well as its members), thought leadership reports, blogs and forums to raise various governance trends where you can share your thoughts and comments as well as our quarterly e-magazine where we share thought provoking article from our members and stakeholders. Please visit our website at [www.csaorg.com](http://www.csaorg.com) to see the resources available.

One of the more positive consequences of travel bans and social distancing has been the increase in virtual events. The hosting of board meetings and AGMs, CPD and training events, and conferences on virtual platforms has broadened the access for participation as well as cut travel and event costs. CSIA hosted its first webinar in July this year in collaboration with Quinlan and Associates on the subject of "Digitisation in a COVID-19 Environment". The webinar explored topics such as global regulatory developments for corporate governance, digitalising board operations and the rise of board portals, and the implications of digital enablement for corporate boards. If you missed the webinar, you can watch it on our website.

We also sponsored the training of Module 9 of the Corporate Secretaries Toolkit on Shareholders, which was kindly hosted by the Chartered Governance Institute of Southern Africa (CGISA) in two parts on 13 and 20 July. The feedback on the training was very positive with more than 200 delegates from South Africa, Botswana, Nigeria and Zimbabwe attending the webinar.





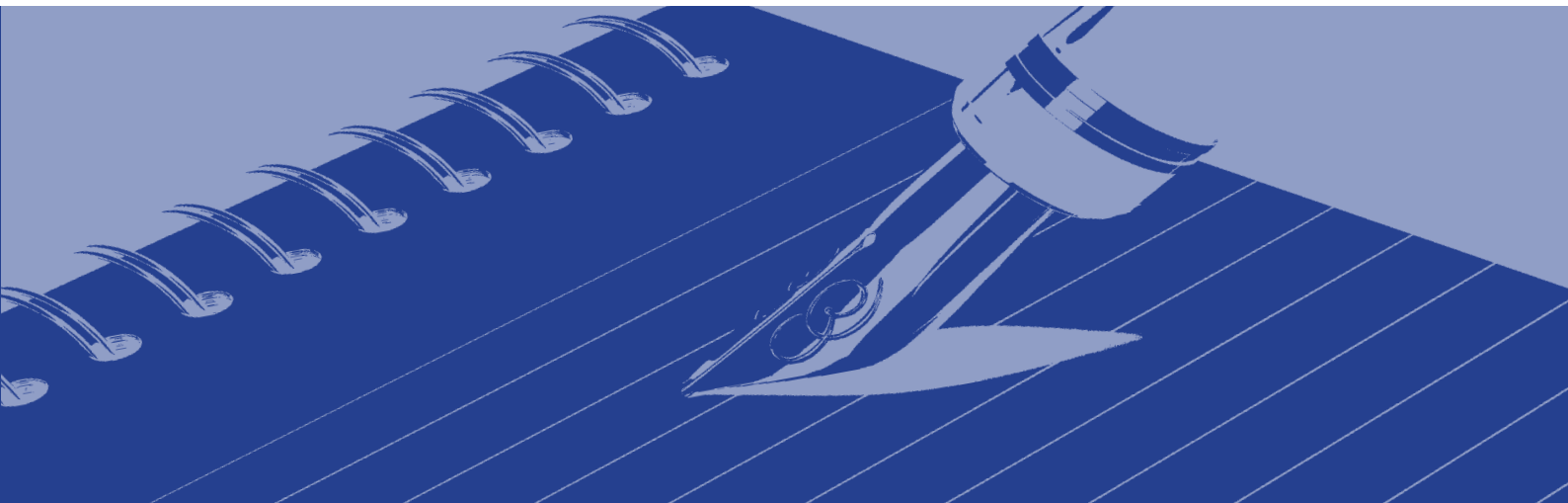

CSIA is also aligning with newly emerging systems and processes by moving to virtual platforms and has partnered with Azeus (a leading IT services provider with more than 25 years of experience in delivering IT solutions) to provide their board management software to CSIA for board meetings. The software has been designed to give users complete control over the entire meeting process and was introduced in August at the meeting of the Executive Committee members. The Convene Board Portal will also be used when CSIA hosts its Annual Council Meeting on 7 and 8 September.

This month we are also launching a comparative analysis thought leadership report *The Role of the Corporate Secretary – Rules, Regulations and Governance – A Global Comparative Survey*. A collation of published works by the ASEAN Corporate Secretaries Network (ACSN) in collaboration with the Hong Kong Institute of Chartered Secretaries (HKICS) and a publication produced by the Institute of Company Secretaries of India (ICSI), as well as information supplied by the CSIA member country survey, this publication will provide insight into the regulation of the corporate secretary and the governance roles they perform as part of discharging regulatory compliance in CSIA member countries as well as selected countries across the globe. Visit our website to see the full report.

CSIA has also collaborated with PwC on a research project, *The Role of the Corporate Secretary and Climate Change*, to provide a view of how climate change is managed in different jurisdictions across the globe, with a specific focus on the role of the corporate secretary and governance professional in driving climate change in organisations. Look out for this research report which will be published in the second half of 2020.

Upcoming events to look out for include “Governance in the New Decade: The Rise of Boardroom ESG” hosted by the Governance Professionals of Canada (GPC), in partnership with CSIA. Join us for a one-day deep dive with global thought leaders, experts and practitioners from Canada and internationally as they prepare boards to address issues such



as pandemics, climate change, racism and other ESG topics impacting boards and their organizations.

GPC will also be hosting their Online Governance Summit on 6 and 7 October and have invited CSIA to partner with them so please join us for a unique experience as GPC debuts an innovative platform which will stimulate a physical event with live webinars, breakout sessions, resources such as videos, documents, and presentations, chat forums and virtual exhibition booths. Take advantage of the CSIA partner registration fee and reserve your seat now!

We remain committed to our objective of representing corporate secretaries and governance professionals across the globe and we look forward to engaging with our members and stakeholders over the next few months to ensure that we work together to shape global governance.

Take care and stay safe.



## How Three South African State-owned Companies have Responded to COVID-19

- Ayanda Ceba (FCG)
- Lindelwa Mngomezulu (FCG)
- Vusi Skosana (FCG)





Ayanda Ceba (FCG)



Lindelwa Mngomezulu (FCG)



Vusi Skosana (FCG)

The COVID-19 outbreak and its global effects have been unexpected and have initiated an urgent need for private companies and state-owned companies (SOCs) to relook at business continuity, risk management, employee and stakeholder health and safety, and continued compliance with governance obligations, says air traffic management solutions and services provider Air Traffic and Navigation Services (ATNS) company secretary Lindelwa Mngomezulu, FCG.

The measures gazetted by government to curb the spread of the virus call for SOCs to comply and consider their sustainability under the 'new normal' caused by the outbreak.

"Sustainability, in turn, requires the company to rethink aspects of governance in a way that supports both compliance

and the longevity and success of the company. The outbreak calls for SOCs to continue to be agile, responsive and responsible corporate citizens," says Mngomezulu.

Mobile telecommunications company Telkom group company secretary Ayanda Ceba, FCG, agrees, adding that the COVID-19 outbreak and the 'new normal' call for resilient leadership and high levels of accountability and a commitment to integrity.

"These are unprecedented times, which arrived suddenly and have never been experienced in the history of South Africa. Therefore, there was a lack of preparedness to deal with the pandemic, which may also have an impact on SOCs' ability to meet their corporate governance obligations."

Mngomezulu says strength and limitation will become apparent in the agility and responsiveness of SOCs in meeting these governance obligations.

The ability of an SOC to adapt to remote working, digital innovation and continued operations will be paramount to meeting its governance obligations, she adds.

“Rigidity in procurement could pose a limitation on the ability of the SOC to adequately meet its governance obligations. SOCs are often weighed down by bureaucratic procurement processes, which slow the response time needed to ensure operations are not disrupted for lengthy periods and can adapt to instant remote working.”

Remote working may also be hampered by a lack of digital innovation and maturity and impede an SOC’s optimal use of its employees during this time, notes Mngomezulu, adding that information technology (IT) governance would need enhanced security to protect the information and records of the entity.

Even prior to the pandemic outbreak, SOCs’ efforts to meet their governance obligations were constrained by factors such as corruption and malpractice, institutional arrangements, weak economic performance and the fiscus, and change in political leadership, highlights public sector developmental programme implementation and management agency Independent Development Trust (IDT) company secretary Vusi Skosana, FCG.

The *Mail & Guardian* newspaper in May reported that the IDT, which has been defined by numerous failed turnaround strategies, is in the process of being dissolved, following the decision in March by Public Works and Infrastructure Minister Patricia de Lille, owing to its “poor project management and performance, among other factors”.

“Besides the IDT’s good delivery record, pockets of poor delivery prevailed and some examples found their way into media publications. The reputational damage to the entity cannot be overemphasised including the withdrawal of the programme and the litigation suits against the SOC currently under way,” Skosana maintains.

“Litigation suits and the absence of a properly constituted board are the biggest consequence of the IDT’s failure to meet its obligations. This has been mitigated through a revised contracting model to ensure protection of the IDT, as the implementing agent, in instances that it experiences challenges beyond its control, including late transfer of programme funds,” he explains.

Moreover, COVID-19 and its disruption of business will compound challenges faced by SOCs and require enhanced adherence to all legal and governance obligations to

avoid penalties such as fines and legal action, warns Mngomezulu.

“Any failure in governance control can be detrimental to SOCs, as any key decisions taken, which would later be found to have been taken contrary to the necessary governance requirements, may be declared invalid or reviewed later. This can cause further negative exposure to directors who may then be deemed to have acted contrary to their duties.”

Mngomezulu highlights that by ensuring that regular meetings are convened and reporting continues, SOCs will negate any negative audit findings and non-compliance issues in respect of any statutory body or the shareholder.

Ensuring that internal governance requirements are met is key, as is ensuring that decisions are taken properly, in a duly constituted meeting with all relevant attendees.

Decisions taken contrary to the governance requirement may be declared invalid when later reviewed, while ensuring that reports due to the shareholder are submitted on time is very critical.

Ceba, meanwhile, emphasises that the failure to meet governance obligations amid the outbreak could see the overall impact being more devastating if SOCs and corporate South Africa do not pull through to decrease its effects on the economy and citizens.

“Non-compliance with regulations could result in fines and a strain on the fiscus of corporate South Africa that could soon be irreparable, causing it to take years to recover to the life we were accustomed to.”

High levels of unemployment could also ensue, which may lead to higher levels of poverty post COVID-19, she warns.

SOCs’ obligations amid the COVID-19 outbreak are the same as they were prior to the crisis.

State entities’ governance obligations emanate from the Companies Act 71 of 2008, The Public Finance Management Act (PFMA), the King IV™ Report on Corporate Governance and the company’s memorandum of incorporation, notes Mngomezulu.

SOCs should act in accordance with the Companies Act, in that they are still expected to ensure that there are proper governance controls in place, states Ceba.

However, she highlights that as Telkom is JSE-listed and has certain exemptions from regulations that govern SOCs, the company is slightly different from an SOC in its truest form.





Mngomezulu says, in terms of governance obligations, it is paramount that the board continues to exercise oversight over the management of the affairs of the SOC and provides executive management with the necessary support to navigate these uncharted times.

“The governance obligations of an SOC, therefore, include the board’s continued provision of stewardship of the company and ultimate support of the necessary transitions emanating from the outbreak. As such, the board of a typical SOC should continue to meet regularly and be kept abreast of any developments.”

In addition, the viability of the company’s disaster plan should be assessed and be communicated to all stakeholders accordingly. Critical consideration must also be given to the continuation of operations and the means to handle any disruptions, says Mngomezulu.

She adds that the board would be further obligated to consider the effects of the outbreak by regularly monitoring the liquidity and budget of the SOC.

“Continued fiscal discipline would be required to ensure that the company maintains effective use of its financial resources, with a specific focus on ensuring that all COVID-19-related procurement meets the necessary governance and fiscal controls.”

Mngomezulu stresses that company secretaries play a critical role in the functioning of the governance controls

in an organisation by ensuring that decisions of the board and management continue to be taken procedurally and in the best interest of the SOC.

“With the support of IT, the company secretary should continue to support the company through innovative means to communicate and ensure that meetings are convened and all statutory reporting obligations continue to be met. This will require embracing IT governance and digital maturity relating to new ways that have the potential to enhance compliance and good governance.”

Before the implementation of the National Disaster Management Act and the subsequent national lockdown, the IDT was already facing a crisis created by predecessors, owing to unprecedented delays in finalising the mandate, corporate form and funding model, Skosana says of his own organisation’s difficulties.

“This has led to hand-to-mouth revenue collections being just sufficient to cover net staff salaries and compromising payments to third parties until the next collection, if any was made.”

The IDT anticipated that the subsequent closure of construction sites would escalate being unable to invoice for the work performed until then and collect revenue. To mitigate against the risk of not paying salaries during the stages of the lockdown, the IDT engaged the Department of Public Works and Infrastructure (DPWI) requesting the prompt transfer of approved funding for the month of April.

The IDT was, however, prepared for COVID-19 from a business continuity perspective, as it procured personal protective equipment and put measures in place to enable key staff members to function remotely, including key contact personnel in the event of emergencies and challenges involving access to IDT infrastructure, says Skosana.

“Those charged with institutional governance convened their virtual meetings, which had initial teething problems but have since been resolved. As such, the IDT was able to meet with the Department of Public Works and Infrastructure (DPWI) on pertinent matters relating to the future state of the entity and continued engagement to ensure that set deadlines are not compromised.”

“As an implementing agent for the Expanded Public Works Programme, the IDT was also on hand to assist the response team in acquiring the services of non-government organisations for the deployment of foot soldiers as required by various departments, as part of the programme’s contribution to the creation of employment opportunities,” notes Skosana.

“Amid the COVID-19 pandemic, South Africa’s subsequent weakened economic state, and ratings agencies’ concerns about SOCs’ financial health, the process of dissolving the IDT needs to be handled with the highest degree of humility from the side of the IDT board, instilling the principle of corporate citizenship as enshrined in the King Report on Corporate Governance,” he says.

“The gravity of this decision has wide-ranging implications, with direct impact on the lives of its employees, the clientele serviced by the entity as well as the interests of other stakeholders affected by the service offerings of the IDT.”

Meanwhile, to adjust to the ever-changing COVID-19 landscape, Telkom has implemented “new ways of working” and triggered groupwide a disaster management team to ensure business continuity and that processes are in place for the company to deliver on its obligations during this difficult time, states Ceba.

In collaboration with government, Telkom is part of the team providing tracking services to track down all people who have been in contact with anyone who tests positive for COVID-19.

“Telkom communicates with its employees frequently, providing updates on COVID-19 and broadcasts to assist employees and its subscribers to be safe during this time.”

Meanwhile, ATNS, as with most companies, has had to review its systems and processes to adopt to the ‘new normal’ to ensure that it meets its governance obligations, explains Mngomezulu.

An urgent transition to an online platform for all meetings has assisted the entity in meeting its obligations.



“A review of deliverables due to ATNS stakeholders was made to ensure that a system was put in place to ensure that compliance and reporting obligations are timeously met, despite the sudden changes in circumstances. The entity proved its agility and was able to adapt and respond quickly to the changes.”

Other key initiatives include a review of the risk register to incorporate COVID-19 -associated risks and link this review to the effects on business continuity.

“ATNS will further respond by conducting an urgent review of its strategy and deliverables,” says Mngomezulu.

The lockdown restrictions issued by government to curb the spread of COVID-19 are a definite limitation to the optimal operation and the liquidity of businesses, says Ceba.

“It is imperative and obligatory for SOCs to act as good corporate citizens and in the best interests of the organisation in advancing the purpose, mission and objectives for which they are established.”

SOCs are established with the goal of advancing economic activity within the economy and to address certain socioeconomic elements, such as reducing unemployment and providing affordable service delivery in transport, telecommunications and power supply, among other areas, she explains.

“We are aware that COVID-19 has, among others, disrupted global trade, halted tourism activities, resulted in loss of employment for some and a shrinking of the economy. Under the circumstances, SOCs have a significant role to play in collaborating with government in its efforts to combat COVID-19 and reduce the negative consequences of the pandemic by, for example, deriving creative ways to prevent job losses and boosting economic activity,” suggests Ceba.

South Africa’s dependence on certain foreign countries is evident and has really undermined the ability of businesses to forge forward within the confines of the limitations placed on global trade.

Therefore, Ceba advances the importance for government to actively mobilise and support local businesses to ensure that most of South Africa’s resources and finished goods are sourced locally in future.

“This will reduce dependency and loss of jobs during and outside such times as our local industry will be the anchor of the economy.”

Skosana adds that the highest degree of maturity is required to appreciate the shift in political landscape and the policy

direction needed to use infrastructure development to rejuvenate economic growth.

Thus, the “new IDT” will continue to create the desired number of job opportunities, facilitate broad-based black economic empowerment, especially for women and the youth, contributing to alleviate poverty and inequality in the country.

Of the IDT’s prevailing situation, Skosana says stakeholder management by the shareholder representative is critical to obtain the buy-in of the affected parties facilitating the process, with involvement of expert advisors, and convince government to adopt the dissolution of the IDT.

The new strategic intent is informed by the state’s experiencing an alarming capacity deficit to meet the demand for public infrastructure delivery, owing to disjointed implementation mechanisms, non-compliance with the established delivery system and implementation mechanisms that undermine demands for fiscal prudence. The state suffers significant losses through project cost overruns and a ‘new’ IDT remains a valuable asset of the state for public infrastructure or the built environment and related service delivery, says Skosana.

“As such, the implementation of the new IDT will require commercially astute leadership to drive its implementation, driving the retention of critical skills and institutional memory and overcoming the reputational damage suffered. Again, restrictions imposed by the prevailing legislation, such as the PFMA and the Deed of Trust, should not be a stumbling block in resolving what remains to be a crisis.”

Mngomezulu adds that the outbreak of COVID-19 will bring forth numerous lessons from global entities and may include prioritisation of risks and reconsideration of strategies to respond to the new risks resulting from this pandemic.

“It will force companies to relook their strategies and put in place contingency plans to allow obligations to be met. While the effects of COVID-19 will be devastating to most entities for months and possibly years after it ends, boards must still implement good governance and ensure that the companies they lead fully meet their mandates,” she concludes.

*This article was first published in the June 2020 edition of boardroom, the official journal of The Chartered Governance Institute of Southern Africa ([www.chartsec.co.za](http://www.chartsec.co.za)). Reprinted with permission.*



# Beyond COVID-19: Taking the Long View Board & Investor Perspectives



While the ongoing coronavirus pandemic continues to necessitate that companies undertake short-term actions in support of their financial stability and resiliency, with the passage of time, both boards and investors are increasingly focused on potential longer term impacts of the crisis and the long-term implications of current day decision-making, as illustrated by these recent perspectives.

### Long-termism: Here's how!

Based on extensive research, including director survey data: "Tone at the Top: The Board's Impact on Long-

term Value"<sup>1</sup> from FCLTGlobal and Russell Reynolds suggests tangible ways in which the board can foster a long-term orientation, including action items that may be positively influenced by the corporate secretary such as board agendas, board materials, meeting documentation, messaging, and follow-up. The focus is on properly balancing short-term and long-term issues, with an emphasis on framing short-term issues in the context of the company's long-term performance.

The instructive publication includes a director "cheat sheet" with these (and other) sound action items:

**A well-functioning corporate board of directors – one that is aligned on time horizons and communicates clearly with management – wields the power to meaningfully influence the purpose, culture and direction of the organization.**

 Use clear language during discussions to emphasize that the primary focus is on the long term.

 Explicitly link executive compensation to long-term value creation.

 Craft boards agendas to include items that are focused on the long-term issues.

 Examine all of the key performance criteria and metrics to ensure they do not inadvertently encourage a focus on the short term.

 Regularly review past agendas and meeting minutes to confirm time is being spent as intended.

 Align compensation to long-term value creation for the board not just management.

 Provide explicit guidance to management to be long-term oriented.

 Compensate board members primarily in stock and consider locking up stock awards through or beyond the term of services.

 Ensure directors are not sending mixed messages to executives via other means.

 Develop a board statement of purpose that emphasizes long-term interest

Notably, the research shows how the views of long-term-oriented and short-term oriented directors differ as respects their motivations to serve on a board and their focus in the boardroom such that companies are encouraged to address potential short-termism in the candidate recruitment process. Along those lines, the paper identifies short-termer "red flags" and suggests how the board's nominating/governance committee can pick up on these indicators in the candidate diligence and vetting processes.

### Corporate purpose: Investors speak

SquareWell Partners' January/February 2020 online survey of investors worldwide collectively managing approximately \$22.1 trillion in assets elicited<sup>2</sup> some surprising and some not-so-surprising views on the relevance of corporate purpose, who should be responsible for delivering it, and how it should be measured and accounted for. Survey respondents were from Stewardship (70%) and Responsible Investment teams (30%). London Business School Professor of Finance Alex Edmans and Wachtell Lipton Partner Sebastian Niles prepared the report's Forward and Concluding Thoughts, respectively.

<sup>1</sup> "Tone at the Top: The Board's Impact on Long-term Value" available at <https://higherlogicdownload.s3.amazonaws.com/GOVERNANCEPROFESSIONALS/a8892c7c-6297-4149-b9fc-378577d0b150/UploadedImages/Tone-at-the-Top-The-Boards-Impact-on-Long-term-Value.pdf>.

<sup>2</sup> "Making Corporate Purpose Tangible" available at [https://higherlogicdownload.s3.amazonaws.com/GOVERNANCEPROFESSIONALS/a8892c7c-6297-4149-b9fc-378577d0b150/UploadedImages/2020\\_-\\_SquareWell\\_-\\_Corporate\\_Purpose\\_Survey\\_Photo\\_\\_002\\_.pdf](https://higherlogicdownload.s3.amazonaws.com/GOVERNANCEPROFESSIONALS/a8892c7c-6297-4149-b9fc-378577d0b150/UploadedImages/2020_-_SquareWell_-_Corporate_Purpose_Survey_Photo__002_.pdf) or SquareWell Partners: <https://squarewell-partners.com/insights/>

**Key takeaways include:**

*Relevance*

- 76% of respondents expect companies to have defined their purpose; 14% do not; and 10% have no opinion.
- Investors most commonly think that defining corporate purpose is important because it is needed to set a long-term business strategy that creates value (93%) or strengthen corporate culture (76%).
- 76% of respondents say that the corporate purpose should drive company strategy; 52% expect the purpose to be aligned with the UN SDGs.

*Setting, Implementation & Disclosure*

- An overwhelming 93% of respondents identify the board as responsible for defining the company's purpose compared to just 55% that identify the senior management team (including the CEO) as having this responsibility; however, investors identified the management team and the board as equally responsible for implementation.
- 55% of respondents expect the corporate purpose to be formalized in a dedicated section within the annual report (or equivalent); however, a formal periodic board (not CEO) statement was also identified as an acceptable vehicle by 45%. Other answer choices also garnered some support, as shown here:



- 86% of investors would expect to see written statements regarding the fulfillment of the company's purpose by the entity responsible for setting it.

*Accountability*

- 64% say they are engaging with companies on their purpose.

How would you expect your portfolio companies purpose to be formalized (you can pick more than one)?

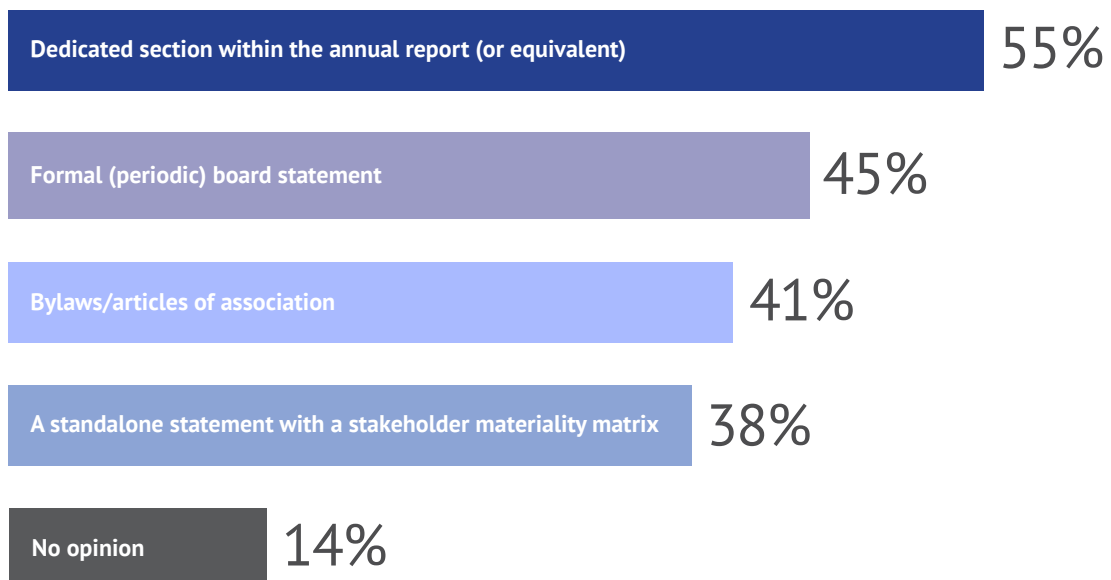





- Investors would most commonly consider a discharge (of the board or CEO, presumably) if they were not satisfied with the company's purpose or its implementation. Short of that, 38% would consider voting against the board chair, and 24% said this would not drive any negative vote.

As is always the case in evaluating survey results, readers should carefully consider any inherent biases associated with the questions asked and the response choices, which – in this survey – did not allow for free-form “Other” responses. Many questions allowed respondents to select more than one answer choice.

### Investors generally pleased with corporate crisis response

Proxy Insight's survey of 70 institutional investors and other stakeholders about companies' responsiveness to the crisis revealed<sup>3</sup> important indicators as respects perceptions of current performance and going forward expectations across a variety of trending topics including investor communications, crisis planning, capital management, and virtual shareholder meetings (VSM).

*VSM takeaways include:*

- A minority of investors (34%) would want to have a say/vote on a company's purpose; 42% said they would not, and an additional 24% had no opinion.
- Investors most commonly would evaluate these factors to determine whether a company's purpose is effective: consistent disclosure regarding its implementation, stakeholder concerns (lack of), employee satisfaction/turnover, and financial performance relative to peers.
- As to VSMs generally, more than 82% of respondents affirmed their support for virtual meetings if certain standards are met to protect shareholder rights compared to just over 58% that affirmed their support of this format without the “shareholder rights” caveat. This compares to 81% who affirmed their support for hybrid meetings.
- Few respondents expect meetings to revert to pre-crisis mode, as shown here:

Do you expect shareholder meetings to change when the crisis is over?

No, they will return to the same way they were.

9.5%

Yes, more will go virtual.

26.2%

Yes, more will use a hybrid physical and virtual model.

64.3%

<sup>3</sup> “COVID-19: New Era for Corporate Governance” available at [https://www.proxyinsight.com/wp-content/uploads/dlm\\_uploads/2020/06/Corporate-Governance-and-COVID-19.pdf](https://www.proxyinsight.com/wp-content/uploads/dlm_uploads/2020/06/Corporate-Governance-and-COVID-19.pdf).

This implies that investors may have benefited from the greater access and participation opportunities associated with this year's VSMs in a way can't be matched with the in-person-only format subject to ensuring shareholder rights on par with an in-person meeting.

Also notable: Just ~8% reported dissatisfaction with companies' efforts to date to minimize disruption and just ~10% with companies' investor reporting. The majority of respondents expressed satisfaction on both fronts.

Respondents consisted of asset managers (58), asset owners (12), research/advocacy groups (7), law firms (6), government/regulator (1) and union group (1).

### Investors give guidance to CEOs

FCLTGlobal / McKinsey's interviews with eight long-term investors elicited<sup>4</sup> sound advice for companies across multiple COVID-19 trending topics.

Key takeaways subject to any liquidity and going concern issues include:

- Prioritizing workforce health & safety
- Helping weaker customers and suppliers survive by retaining their business, if feasible
- Looking for and pursuing crisis-prompted opportunities (e.g., M&A, new talent, less real estate)
- Reducing emphasis on dividends and stock repurchases
- Regular and transparent communications to investors about the impacts of the pandemic on the business and its prospects, whether and how it will recover

Importantly, all of the foregoing is couched in the context of each company's liquidity position, i.e., investors don't expect companies with insufficient liquidity or going concern threats to take actions inconsistent with survival. However, if companies are experiencing liquidity issues, investors expect them to communicate frequently about their status and how these concerns are being managed or mitigated.

Investors represented Invesco, SSGA, Kindred Capital, Pzena Investment Management, Counterpoint Global, Autonomous Research US, Goldman Sachs, and MFS Investment Management.

### COVID-19 responsiveness: Investor engagement

The Principles for Responsible Investment (PRI) published guidance<sup>5</sup> for investors on topics to address with their investee companies to gauge the quality of their responsiveness to the pandemic across the key themes of business continuity, employee health and well-being, and alignment with long-term value creation.

More specifically, the guidance consists of a series of questions for investors to ask across these categories and sub-topics:

*Business continuity – for employers, suppliers and communities*

- Operations
- Supply chain management and human rights
- Communication with stakeholders

*Employee health and wellbeing – to ensure an engaged workforce*

- Human capital management
- Safety and security of employees and customers

*Alignment with long-term value creation*

- Financial and strategic resiliency
- Financial alignment between the company and stakeholders
- A sustainable, net-zero economy

The guidance - which is intended to evolve based on investor feedback - was co-developed by the PRI, Business & Human Rights Resource Centre, CalSTRS, and APG and reflects contributions thus far from LGIM.

*This article was provided by The Society for Corporate Governance (www.societycorp.gov.org). Published with permission.*

<sup>4</sup> "Navigating COVID-19: Advice from long-term investors" available at <https://www.fcltglobal.org/resource/covid-19-advice-investors/>

<sup>5</sup> "AGM Season 2020: Investor questions on COVID-19" available at <https://www.unpri.org/covid-19-resources/agm-season-2020-investor-questions-on-covid-19/5828.article>.

# COVID-19 Crisis: E-Government Platform as Rescue Vessel

■ **Mohammad Shahajahan** CPFA, CFC, FCS  
Chairman, Journal & Publication Sub Committee  
Institute of Chartered Secretaries of Bangladesh (ICSB)



**B**y July 2020, COVID-19 infected over 16 million people and caused the deaths of about 650,000 worldwide<sup>1</sup>. In every day the infected cases are increasing in Americas, Asia and Africa whereas in Europe and Western Pacific are declining which gives some aspiration for abating the COVID-19 infection. On the other hand, Australia has reported new wave of infection from July, 2020 which is alarming. The spread of Covid-19 has shaken people's lives around the world in an unprecedented way, threatening health, disrupting economic activity, and hurting wellbeing

and jobs<sup>2</sup>. In the COVID-19 pandemic situation, due to lockdown in most of the counties of the world, trade and investment has become vulnerable and economic downturn has sharply emerged. Borders closure in response to COVID-19, international flights interruption, travel restrictions and changing national priority has drastically impacted the trade and investment globally. The economic disruptions triggered by the COVID-19 pandemic are huge, with global GDP projected to contract sharply in 2020 and global trade predicted to fall drastically<sup>3</sup>.

<sup>1</sup> <https://www.worldometers.info/coronavirus/>

<sup>2</sup> L. Boone, 2020: After the Lockdown, a tightrope walk toward recovery, published by OECD.

<sup>3</sup> UNCTAD, 2020: Post-COVID-19: Investment Promotion Agencies and the "New Normal".



An extraordinary shock has emerged as economic activity has collapsed across the OECD during shutdowns, by as much as 20% to 30% in some countries<sup>4</sup>. Tourism which accounted 29% of world services exports and 3 billion jobs globally became critical sector during COVID-19 pandemic<sup>5</sup>. The local private sector especially Micro, Small and Medium-sized Enterprises (MSMEs), which often have investors' support due to backward supply and other types of linkages, are prominently impacted during the COVID-19 pandemic. The global and national value chain, supply chain and marketing of the national and multinational companies has hampered. The Global Foreign Direct Investment (GFDI) has predicted by UNCTAD in its latest projection to fall by 40%. High uncertainty are waiting for the world as OECD projected in two scenarios as follows:

*Double-hit scenario:* A second wave of infections hits before year-end and a renewed outbreak of infections triggers a return to lock-downs which caused world economic output plummets 7.6% this year, before climbing back 2.8% in 2021 and the OECD unemployment rate nearly doubles to 10% with little recovery in jobs by 2021<sup>6</sup>.

*Single-hit scenario:* If second wave is avoided global economic activity falls 6% in 2020 and OECD unemployment climbs to 9.2% from 5.4% in 2019. Living standards fall less sharply than with a second wave but five years of income growth is lost across the economy by 2021<sup>7</sup>.

COVID 19 has massive global negative externalities and it encompass the changes in our natural ecosystems which has extensive economic and financial damage that effects human life directly. Therefore, COVID-19 pandemic is classified as Green Swans as well as Black Swans as it has exponential growth of deaths, infections and negative externalities. The Swiss-based Bank for International Settlements (BIS) research confirms that the short-term costs of COVID-19 are significantly higher than for past epidemics, precisely because of the global sudden stop due in part to containment measures. The current estimated impact on global GDP growth for 2020 is around -4%, with significant downside risks<sup>8</sup>. As COVID-19 involves global nature of risks, more global coordination and local cooperation is crucial to prevent these risks and also require changes in risk models and mindsets in many directions and by many agents i.e. central banks, governments, civil society, the private sector etc.

The severity of the economic downturn would be depended on the permanency of the pandemic, the country perspective, the national and international policy effectiveness and finally, aptitude to readjust with the new normal of the COVID-19.

Vaccine and relevant treatment not yet widely available. Therefore, governments of many countries are initially imposed lockdown for months like in Bangladesh countrywide lockdown was continuously about for three (3) months for slowing down the infections and deaths. But the long-term lockdown has severe impact on economic activity like frozen business activity in many sectors, widened inequality, disrupted education and undermined confidence in the future and it has a vicious circle impact on the economy and society. Therefore, for preventing the health and economic crisis globally governments and central banks have put in place wide-ranging policies to protect people and businesses from the consequences of the sudden stop in activity of the countries throughout world with special care like physical distancing and testing, tracking, tracing and isolating (TTTI) or dividing the country in different (red, yellow and green) zones aiming to address COVID-19 new normal.

To avoid infection and work with the new normal of the COVID-19, e-government platform became crucial for the professionals and service providers to stay open for business to deliver goods and services to people and society by maintaining physical distancing and testing, tracking, tracing and isolating (TTTI). Governments, corporate houses and MSMEs are required to adopt e-government platform to provide online services for *fiscal rescue measures* like i) social security administration for temporarily retrenched workers; ii) processing of business grant requests; iii) handling of tax relief or late payment applications; iv) monitoring of disbursements; v) post-crisis recovery of state aid through tax systems; etc.; and *processing trade operations* like i) processing; ii) company registrations; iii) transferring property title; iv) issuing business licensing<sup>9</sup>; etc. Many countries uses the e-government platform of UNCTAD, a value-for-money, adaptable and easy-to-implement solution for governments and donors, for continuing services online during the pandemic situation by avoiding the physical interaction<sup>10</sup>. Some examples of using e-government platform of UNCTAD are - Banin, Iraq and Guatemala for

<sup>4</sup> L. Boone, 2020: After the Lockdown, a tightrope walk toward recovery, published by OECD.

<sup>5</sup> UNCTAD, 2020: Covid-19 and Tourism: Assessing the Economic Consequences.

<sup>6</sup> <http://www.oecd.org/economic-outlook/june-2020/>

<sup>7</sup> <http://www.oecd.org/economic-outlook/june-2020/>

<sup>8</sup> L Pereira da Silva, 2020: Green Swan 2 – Climate change and Covid-19: reflections on efficiency versus resilience.

<sup>9</sup> UNCTAD, 2020: How UNCTAD's e-government platform helps countries stay open for business during COVID-19.

<sup>10</sup> UNCTAD, 2020: How UNCTAD's e-government platform helps countries stay open for business during COVID-19.

e-registration of businesses, Bhutan for fully automate all business licensing procedures, Cameroon starting MyBusiness.com in 9 provinces with funding from the EU and France, Cuba launched e-Regulations system, Kenya, Rwanda, Uganda and Tanzania installed Trade Information Portal to describe trade procedures online, step by step by avoiding physical interaction, El Salvador for MSMEs account online tool for small entrepreneurs, Mali for online registration system of social security and tax.

With the request of UN Secretary-General and in support of the UN Crisis Management Team, a Supply Chain Task Force has been convened to establish the COVID-19 Supply Chain System (CSCS) for requesting and receiving globally sourced COVID-19 critical supplies like personal protective equipment, diagnostics and clinical management by using online COVID-19 Supply Portal<sup>11</sup>.

Government offices in Bangladesh are using e-nothi for official filing, communications and decisions. During COVID-19 e-nothi usages has increased rapidly to remain open businesses of government offices. Financial activities of government offices (budgeting, bill submission, bill passing, payment, etc.) are being undertaken through using online iBAS++ system in Bangladesh. For maintaining physical distancing and to ease project financial management activities during COVID-19 and afterward, Finance Division and World Bank, Bangladesh office jointly has initiated Project Management Accounting Portal (PMAP) for managing financial management of the development partners assisted government projects.

Multinational Companies (MNCs) and public limited companies in Bangladesh started virtual offices considering stay home and save life. Many companies are allowing their employees to work at home by using online platform. Value Chain and Supply Chain Companies are using e-platform (like e-Business and f-Business) for advertising, promoting, ordering and delivering their products/services. Business meeting, discussion and decision making are happening through e-government platform like Cisco WebEx, Zoom, Microsoft Teams, Google Meet, Goggle Hangouts, Skype, Facebook, Viber, LinkedIn, WhatsApp, etc. Bangladesh Securities & Exchange Commission (BSEC) is allowing relaxations regarding compliance with the provisions of the Listing Regulations or other securities laws relating

to holding of Annual General Meeting (AGM), Extraordinary General Meeting (EGM), Board of Directors' Meetings, publication and dissemination of Price Sensitive Information (PSI), and requirements of monthly/ quarterly submissions and other submissions to the Commission as well as holding AGM/EGM/BOD meeting using digital platform through webinar/ teleconference/ any means of electronic devices due to worldwide spread of corona virus<sup>12</sup>.

When digital transformation become popular due to physical distancing advantages during COVID-19, another unseen threat rising in the digital space: the risk of cyber-attacks that target on our increased reliance on digital tools and the uncertainty of the crisis. The World Economic Forum (WEF) has identified three (3) reasons robust for cyber-attacks- a) A heightened dependency on digital infrastructure raises the cost of failure; b) Cybercrime exploits fear and uncertainty; and c) More time online could lead to riskier behavior<sup>13</sup>. To avoid the risk of cyber-attacks maintaining high level cyber-security must be ensured the three steps- a) setting appropriate cyber hygiene standards including washing hand and devices with appropriate alcoholic cleaning solution, long and complex wifi password, careful in reusing password across the web, use a reliable VPN etc.; b) more attention on verification in time of software installation, providing personal information, signing and verifying; c) Data authentication and use trusted sources of data<sup>14</sup>.

Finally, the COVID-19 crisis is not only generating new sources of inequality but also aggravating the inequalities that existed before the crisis<sup>15</sup>. Due to economic and social shock of the COVID-19 pandemic youth, women, disadvantaged groups, informal and non-standard workers, low-income daily labors, low-skilled workers and SMEs has already disproportionately affected globally. Most of the cases e-government platform opportunities are out of their capability and they suffer from weaker coverage by social protection tools. Therefore, Governments have to act quickly and boldly to provide immediate technological and financial support for these marginal people, their dependents and businesses as well as tackling these inequalities by building back better.

*This article was provided by the Institute of Chartered Secretaries of Bangladesh (www.icsb.edu.bd). Published with permission.*

<sup>11</sup> WHO, 2020: COVID-19 Supply Chain System: Requesting and Receiving Supplies.

<sup>12</sup> Bangladesh Securities & Exchange Commission, 2020: Office Order no.SEC/SRMIC/94-231/25 Date:8 July, 2020.

<sup>13</sup> A. Pipikaite & N. Davis, 2020: Why cyber security matters more than ever during the coronavirus pandemic, WEF.

<sup>14</sup> A. Pipikaite & N. Davis, 2020: Why cyber security matters more than ever during the coronavirus pandemic, WEF.

<sup>15</sup> L. Boone, A. C. Sanchez, N. Kergozou, S. Scarpetta, 2020: Building back better: enhancing equal access to opportunities for all.

# Brought to Light

## ■ Kerry Round

Founding Director of Round Governance Services

If you have ever been pond clearing, you'll know that blanket weed and algae tend to rise to the surface after a good storm. It hasn't just suddenly grown, it was always there, concealed in the darkness.

Metaphorically speaking, I feel like a lot of ponds are being cleared at the moment. The pandemic has brought to the surface many of the issues that senior leaders might not previously have addressed, for whatever reason.

In this article I talk specifically about diversity, diversity in all of its forms. Whilst my focus is on board and senior management diversity, I will look at how topics that

are current in today's society also impact the wider workforce.

Diversity in the boardroom can be described as actively embracing, and openly seeking to include, people with characteristics outside the perceived norm, onto the board and into senior management. Diversity is a positive word. Diversity is about gender and it is about race but it is also much more. It's about social backgrounds, age, religion, education, (dis)ability, (neuro)diversity and personal and cognitive strengths. Diversity is about acknowledging and appreciating the benefits of having both a diverse board and a diverse workforce.

Boards need to make conscious changes to reassure the workforce that diversity is valued.



### The governance toolbox

Governance professionals know that a plethora of tools already exist to help achieve equality for all. We already have legislation, regulations and good practice in place for organisations of all kinds, from not-for-profit all the way through to FTSE 100 companies. Governance professionals know this and we're in a privileged position to ensure that business leaders do not just pay lip service to the wider subject. Using these tools, we can help them be transparent about their board and senior management appointments and to make those appointments consciously. We do not want our boards to 'try' to reach diversity targets but to exceed them.

### The gender pay gap statement

A joint statement made on 24 March, by Minister for Women & Equalities, Elizabeth Truss, and EHRC Chair, David Isaac, said: "It is only right to suspend enforcement of gender pay gap reporting this year". I cannot see why 'it is only right'. I contacted them both and I did not get very far when I tried to dig deeper into the reasons behind suspending enforcement this year.

For context, businesses and charities are required to publish their data and narrative by 4 April each year and public sector organisations must publish by 30 March each year. This data is based on the previous 12 months' information. I cannot help thinking that this decision was made by people who do not necessarily understand how the figures are put together in the first place.

My view would have been not to suspend reporting but to pause, to postpone and to submit the gender pay gap figures when the storm has settled and resources were accessible once again.

The gender pay gap legislation is by no means perfect. It allows large corporations to report for their individual companies (with 250 or more employees) instead of reporting for the whole group of companies together. I cannot help wondering what difference that might make to the gender pay gap figures, but, at least it was something. It was sending a strong signal about the importance of commitment to gender equality in the workplace. Gender pay gap reporting was supposed to be transparent and was supposed to allow for year-on-year comparison.

I hope that companies can see the benefit and the value of continuing to report. I think 'pausing' to deal with urgent and critical business is understandable but I hope companies pick this back up and continue to send a very clear message to their workforce that the gender pay gap is important.

We need to remember that when talking about the gender pay gap, we're not talking about equal pay; receiving unequal pay is already unlawful, in fact, 29 May marked 50 years since the Equal Pay Act received royal assent in the UK.

### Black lives matter

For business leaders publicly asking what they can do in light of the Black Lives Matter campaign, particularly for those in the FTSE 350, I hope that they go beyond making diversity statements and really 'think' about the issue and how they want to address it and, if relevant and appropriate, set objectives and commit to them.



#### Questions to consider:

- How does your organisation measure diversity?
- How diverse is your board?
- Does your board represent and reflect your stakeholders?
- Do your Nomination Committee terms of reference state the responsibility of ensuring a diverse pipeline?
- How focused is your organisation on culture?
- Do you have a Board Diversity and Inclusion Policy?
- Do you have a Workforce Diversity and Inclusion Policy?
- Do you have a Succession Policy that covers a diverse pipeline?
- Does your organisation have diversity targets for its board and senior management?
- Do you offer workforce mentoring?
- Have you considered or participated in reverse mentoring?
- Does your organisation have any diversity training and is this available at all levels?
- Do your recruitment processes include diversity?
- Are your HR systems ready to record ethnicity data?

This is not a 'new' topic or issue for companies to address. The Parker Review was published back in 2017 and gave three clear recommendations to organisations on diversity:

- increase the ethnic diversity of UK boards by proposing each FTSE 100 board to have at least one director from an ethnic minority background by 2021 and for each FTSE 250 board to do the same by 2024
- develop a pipeline of candidates and plan for succession through mentoring and sponsoring
- enhance transparency and disclosure to record and track progress against the objectives.

The reality is that the FTSE 350 has a long way to go before it achieves ethnic diversity on its boards. The 2020 Parker Review found that 37% of FTSE 100 companies surveyed do not have any ethnic minority representation on their board, whilst on the FTSE 250, 69% of companies did not meet the target. Across the FTSE 350, there are only 15 directors of colour who occupy the position of Chair or CEO. I'm really keen to see whether there will be any meaningful impact after the Black Lives Matter campaign and it would be really interesting to check in on these figures in 12 months time.

#### **Ethnic pay gap reporting**

I've seen a lot of organisations criticised for not disclosing their ethnic pay gap figures. Unfortunately, the reality is that organisations are unable to report their ethnic pay gap with any real meaning at the moment. The government closed the consultation on ethnic pay gap reporting in January 2019 and to date, there have been no developments.

A voluntary ethnic pay gap disclosure can only carry so much weight when there are no guidelines as to:

- how to identify ethnicity categorisations
- how to encourage employees to volunteer this information (of course it can't be mandatory, can it?)
- how to report as there is no criteria that would ensure a consistent approach
- how international companies can report on employees in jurisdictions where the collection of this data is illegal.

Without a clear reporting framework then valid comparisons between organisations or between year-on-year reports within the same organisation are not possible, however useful they might be for internal analysis. Any voluntarily reported numbers will lack the significant impact that is intended.

### FTSE small cap and AIM 50

If you haven't yet had a chance to read the Company Matters report on board diversity in AIM and FTSE Small Cap companies (SMC), it makes for interesting reading. Their research (published in January 2020) found that board diversity in these indices is increasing but it remains low, particularly in the AIM UK 50. In these companies, 15% of directors are women and 36% have all-male boards. The top 100 companies of the FTSE Small Cap index have more encouraging figures, showing a gender balance of 28% women. Ethnic diversity on boards is lagging across the AIM and FTSE SMC 100 companies. 96% of directors on AIM UK 50 and FTSE SMC 100 companies are white, while 80% and 81% of these boards are all-white.

I discussed this issue with Bernadette Young, Director of Chadwick Corporate Consulting and she commented: "The Black Lives Matter movement has highlighted some of the disadvantages that black and other minority ethnic individuals suffer in education, criminal justice, the workplace and socioeconomic factors. Businesses cannot solve all these problems but by removing the artificial barriers which hinder the talents of those of a certain class, colour, gender or sexuality, they can help create fairness within their own sphere. Harnessing the true potential of all must surely help drive the success of organisations and wider society in the long run. It's not just an issue of ethics and equity, but of sound business and economic sense".

### Next steps

We are not going to see any meaningful change if we do not look beyond making public statements. We need conscious changes made by the board that reassure the workforce that diversity is valued. We need a diverse workforce that can access clear progression routes to senior management roles. And similarly, there should be career pathways identified and communicated to that diverse group of senior managers, so they are able to rise to board level.

### Diversity toolkit

- Equal Pay Act 1970
- Gender Pay Act
- UK Corporate Governance Code 2018
- Quoted Companies Alliance Code
- The Wates Principles
- The Hampton-Alexander Review
- The Parker Review

If you step away from the moral and ethical aspects of having a diverse workforce and board, it comes back to an obvious choice for me.

Why wouldn't you choose to have a board of directors that was reflective of its customer base and in doing so more intuitive and more responsive? Why wouldn't you seek to be inclusive and to boost the decision-making quality of your board, with new perspectives? Why wouldn't you, in the best interest of your organisation, want to surround yourself with complementary skills, experience and diversity characteristics?

When a woman earns £1 for £1, the same as a man earns, then there will be no need for gender pay gap reporting. When we no longer need to celebrate a BAME appointment to the board because these happen everyday, then there will be no need for Ethnic Pay Gap reporting. When the barriers to advancement affecting women and other minorities are removed, then there will be no need to continually highlight them. Until then, why not take a reflective look at your own organisation? It's time to be bold. And, it's time to be brave. Let's make change happen.

*This article was first published in the August 2020 edition of Governance and Compliance, the official journal of ICSA: The Chartered Governance Institute ([www.icsa.org.uk](http://www.icsa.org.uk)). Reprinted with permission.*



# Taxation of the Platform-based Economy

■ **Dr Jag Kundi**  
Independent Accounting &  
Finance Scholar Practitioner

As economies shift into intangibles as drivers of economic value, is the present global tax system fit for purpose? Dr Jag Kundi, a Hong Kong-based scholar-practitioner active in the FinTech space, looks at the role that blockchain can play in improving and upgrading the global tax system.



This article will consider how taxation on digital economies is limited in its scope, effectiveness and collectability. This last point of collectability is a real threat to governments around the world as the digital economy knows no borders or sovereign territories. There are big impacts on an economy if tax is not collected correctly. These risks would cover:

- loss of revenue for government expenditure impacting on reduced public services
- delayed interest payments on government bonds, which could make sale and holding of government bonds less attractive, and
- depreciation of the national currency thereby impacting international trade.

The role of the blockchain will also be considered as a way of potentially improving and upgrading the tax system.

### Is the present tax system fit for purpose?

In today's world, taxes may be considered as a necessary requirement for any civilised society to function. Originally this was not the case. Tax was used as a 'temporary' means by government to finance war. Every war from ancient times to today was paid for by some kind of tax, from the time of Alexander the Great to the American Revolution. You could argue that if you want to end war, end taxes!

Tax is one area that impacts us all. The famous quotation 'Nothing can be said to be certain, except death and taxes' attributed to Benjamin Franklin in 1789 actually has its roots earlier in *The Cobbler of Preston* by Christopher Bullock (1716) who wrote 'Tis impossible to be sure of anything but death and taxes'.

Taxation in a 'bricks and mortar' based economy is relatively simple. The physical presence or permanent establishment test would be applied and the tax calculated. As a local citizen, individual or corporate, being physically located within a defined territory would be the basis for calculating tax – this became known as a territorial-based tax system, that is, one in which a government would usually only tax income earned in that territory. Gibraltar, Hong Kong, Singapore and Macau are examples of territorial-based tax systems.

An alternative taxation system called 'worldwide taxation' simply aggregates all income, regardless of where earned, and taxes it as one lump sum. The US is an example of a worldwide taxation system. The pros and cons of either system are not the focus of this article, as both depend on the physical location of the individual or corporation for the basis of their initial tax assessment.

This approach worked well for the taxation of tangible assets and physical goods within physical borders as indicators of economic value – who owes/owns what. As long as the underlying assets were tangible, that is observable and measurable, it was perfect for tax authorities to use this as the basis for financial record-keeping and thereafter for tax assessment.

Consider the industry development timeline below (see Figure 1 on next page) and see how the time periods between each successive period of industrialisation are being squeezed. The whole pace has quickened dramatically with the shift to a digital world where the offline world is now becoming more and more connected online. Originally the process was evolutionary in nature taking time for progression; today it is more revolutionary in nature, due to rapid and disruptive change. The digital world has impacted/ disrupted nearly every industry from media, communication, entertainment, education, finance and logistics. Today physical reality is being displaced by virtual reality and augmented reality.

Industry 4.0 has a host of enabling technologies that promises to usher in a golden era in the digitisation of manufacturing.

Enabling technologies include:

- Internet of Things (IoT)
- cloud computing
- artificial intelligence (AI) and machine learning (ML)
- data analytics, and
- advanced smart robotics.

Industry 4.0 will take what was started in Industry 3.0 with the adoption of computers and automation, and enhance this with smart and autonomous systems fueled by big data and machine learning – all intangible. As everything is being done faster, cheaper and at scale, these technological innovations are driving marginal costs to near zero, making goods and services priceless, nearly free and abundant and no longer subject to market forces.

The challenge here for national tax systems will be based on a number of factors:

- absence of physical presence
- strong dependence on intangible assets
- complex nature of transactions conducted digitally, and
- difficulty of qualifying assets, activities and types of income.

In the 21st century, value is being defined, created and shared across digital platforms and much of this value is intangible in nature – such as big data. As part of their digitalisation, companies have been quick to transform part or all of their business operations to a platform where the exchange of value can be done with less friction.

**Figure 1: Consider the industry development timeline**

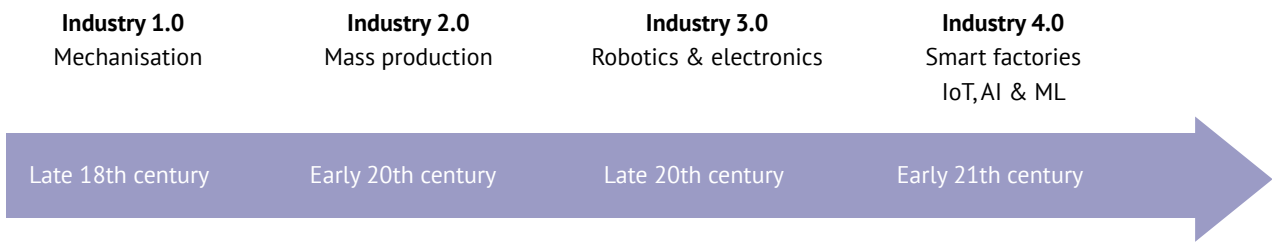

**The platform-based economy**

As the tech consultancy firm Applico ([www.applicoinc.com](http://www.applicoinc.com)) puts it, 'A platform is a business model that creates value by facilitating exchanges between two or more independent groups, usually consumer and producers. In order to make these exchanges happen, platforms harness and create large, scalable networks of users and resources that can be accessed on demand.'

Consider the following:

- Alibaba and Amazon are the largest retailers in the world but they don't own any stock or inventory
- Uber is the biggest taxi company in the world but it doesn't own a taxi
- Airbnb has become the biggest accommodation provider but owns no property, and
- Facebook is the largest media company in the world but hardly creates any of its own content.

All of these companies are based on 'digital platforms' and are examples of Unicorns (relatively new companies that quickly attain a market valuation of more than US\$1 billion).

As economies shift into intangibles as drivers of economic value, the present financial system as the basis for assessing tax needs an upgrade. Witness companies like Apple that create significant value out of intangible assets through combining design and software – both intangibles. These are then shaped to give the consumer the ultimate user experience – again an intangible. This may help to explain why Apple had a market value in excess of US\$1.3 trillion in December 2019, and why Alphabet (the parent company of Google) and Amazon are close to these breathtaking valuations – both companies heavily vested intangibly.

With Industry 4.0, the old model of investing in tangible assets (plant, property and equipment) is quickly being replaced with the concept of being lean, agile and 'asset-light'. A more updated variation of the asset-light model is also referred to as the OPEX model, as opposed to the CAPEX model. CAPEX implies leaders make investments in tangible fixed assets, whereas OPEX implies that, wherever possible, leaders should try to rent, lease or outsource the

use of assets, rather than buy themselves. A classic example here would be computer storage – rather than keep buying more physical storage, companies are switching to cloud-based storage such as Amazon Web Services. Instead of buying your personal edition of MS Office productivity software, use it on the cloud via a subscription-based model.

One last example here shows the full impact this change is having. According to Statista.com, in 2017 Facebook, Google and Apple employed in total 236,105 full-time employees with a total market capitalisation of about US\$2.2 trillion. Compare this to say Walmart employing over 2.3 million people, Volkswagen over 664,000, Hon Hai Precision (Foxconn) over 667,000 and a combined market capitalisation of US\$323 billion. The tech companies have a market capitalisation almost seven times that of their old economy peers, but employ 15 times fewer employees. The savings and value dynamics operating here are obvious to the corporates. Now factor in the multiple jurisdictions where intellectual property, cloud storage and a distributed management and employees (recruited via the 'gig' economy) can be based – and the savings, with tax included, can be in the order of magnitudes.





Consider Amazon: in 2017 its UK operations, which handle the packing and delivery of parcels and its related customer services, reported an increase in revenues from £1.46 billion to £1.98 billion and pre-tax profits of £72 million. However, it paid just £4.5 million in corporate tax, which works out at a rate of 6.25% compared to actual corporate tax rates in the UK of 19%. To further complicate matters, sales for Amazon's UK retail sales are reported through a separate company in Luxembourg, but its US filings reveal that UK revenues hit US\$11.3 billion last year, a healthy 19% year-on-year rise.

Tax authorities struggle to check and verify the tax liabilities of such global businesses operating worldwide supply lines and complex organisational structures. Many multinational corporations (MNCs), for tax purposes, set up a local operation as an individual company, which then pays the parent (or other subsidiary) company for goods, services and intellectual property. The price they pay is set under a system called transfer pricing. However, the MNC will have an incentive to maximise profits in low-tax jurisdictions and hence pay less tax. The same incentives work in reverse – maximise allowable expenses (for tax purposes) in high-tax jurisdictions.

An example here would be where a French-based subsidiary of an MNC might pay an 'inflated price' for services provided via another subsidiary based in a tax haven such as the British Virgin Islands. This would have the impact of reducing the French subsidiary's tax liability and protect the cash transferred from French tax rates. The overall aim here is to minimise the group tax liability as tax payable involves real cash outflows (to the government) rather than the accounting fiction of tax expenses, which are based on accruals (estimates based on timing differences of cash flows).

### The potential role of blockchain

In this context, rather than fight the digital economy, government could turn to technology as an ally to improve the tax system. Blockchain technology has emerged at a time when many in the tax world are rethinking whether the present tax system is still fit for purpose. As mentioned above, the present tax system was designed for the days when physical goods were traded, bought and sold. Digitalisation of tax is gaining traction with both developed and developing countries adopting various electronic tax reporting schemes. Does it still make sense for tax authorities to collect tax as they always have done in the past? This is more likely a question for tax policy rather than technology.

Blockchain provides digital trust. It is a distributed and decentralised ledger technology that permanently and securely records every transaction made on its network. Combined with smart contracts (contracts in the form of computer code that are activated automatically on a blockchain, without the need of a third party, such as a lawyer or bank, when certain conditions are met), blockchain has the potential to revolutionise governance by making the transaction of money, property and shares transparent and conflict free amongst its users. These benefits can be categorised as set out below.

- Transaction processing and data storage costs can be reduced, and a decentralised network can be faster and do more than a centralised server.
- It is almost impossible to overwrite or make changes to the ledger without the related network members being aware or agreeing to such changes. The secure cryptography also improves security.



- Accountability and transparency is enhanced by making the origin of every transaction known and public, which in turn will assist in making the tax computation easier and indisputable.
- Automation of tax transactions driven by smart contracts will make the process of tax compliance less of a worry. Smart contracts can automate the execution transactions upon the satisfaction of predetermined and mutually agreed-upon conditions.
- Blockchain has the potential to make tax payments more secure, and with the addition of artificial intelligence and robotic process automation will also help increase compliance and reduce fraud.

Because blockchain is an objective, mutually agreed-upon record of transactions, multiple parties can verify every step of a process. This will enable a blockchain-based financial ecosystem to carry out all financial transactions in an objective, transparent and decentralised manner. This would imply that the record of every single transaction is visible to anyone on the network. Such records are unchangeable. The implication of this is startling, as when the financial details of every transaction become traceable, the ownership of assets and money can be easily determined and tax due thereon easily calculated – not just easily calculated but also automatically! Thus reducing the opportunity for minimising tax liabilities and reducing costly tax disputes. The ‘tsunami-like’ impact this will have on the financial, accounting and legal industry cannot be understated.

A further development here would be to automate the tax collection via the smart contracts on the blockchain, resulting in instant settlement of sales tax, value-added tax (VAT) or goods and services tax (GST). For example, a supermarket group could bring together supply, sales and tax within a distributed ledger that records all transactions and automatically pays the associated sales tax/VAT/GST. This approach is gaining interest in the European Union (EU). In November 2018, the European Parliament Special Committee on financial crimes, tax evasion and tax avoidance published a draft report which contains recommendations on fighting cross-border VAT fraud. The report encourages member states to explore the possibility of a plan to place cross-border transactional data on a blockchain and to use a secure digital currency that can only be used for VAT payments.

Smart contracts can be programmed by government or their appointed regulators to act in accordance with the local tax laws. The smart logic of such contracts can allow them to be programmed to maximise all the allowable claims and deductions available to the taxpayer. This means that neither party then needs to keep track of their finances and potential tax liabilities, as the smart contract



will automatically handle this by making the relevant deduction (or refund) to the taxpayer’s account. Real-time tax reporting and collection would be the logical extension of the smart contracts here.

Another advantage arises from the use of the blockchain-based approach. Corporate fraud can be prevented or significantly reduced, as such systems can account for every transaction, making it easy for tax authorities to calculate taxable earnings and bill them accordingly. This approach will also provide the evidence in case of non-compliance or tax avoidance to support legal action. And in the face of strong, immutable proof such as that offered by blockchain records, trust and fairness will prevail.

While blockchain may provide governments with an alternate method to tax the digital economy, several challenges lie ahead.

1. Due to the decentralised nature of a public blockchain, the computer code is held on many computers/ servers simultaneously. To protect and preserve the blockchain data integrity it would rarely be based in just one jurisdiction – most likely the data would be held on multiple computers/ servers and based in multiple jurisdictions. Additional issues would arise here around where the servers are located and also the ‘miners’ who mine (validate) the blocks on the blockchain. So where is the value-added created and where are the assets based for tax purposes?



2. A further complication would be the question of who owns the blockchain. A public blockchain could have multiple ledger owners and therefore this could create potential controversy around the income attributable to participants, and also ownership of the underlying database assets.
3. Linked to point (2) above is the creation of intangible assets – how to measure the value created in different market jurisdictions by the users of the platforms and the digital infrastructures.

Points 1 and 2 above relate to how tax rights can be attributed to any tax jurisdiction when the digital economy can generate profits without physical presence and without setting up a permanent establishment. Governments and regulators facing the challenge of digitalisation of their economy are attempting to deal with these vexing issues both collectively and individually.

In May 2019, the OECD released a document known as 'Programme of Work to Develop a Consensus Solution to the Tax Challenges arising from the Digitalisation of the Economy'. This is currently under discussion among members and should give rise to a final technical paper in December 2020.

The EU in March 2018 issued two proposals that would have delivered new ways to tax the digital economy:

1. an interim measure focused on a Digital Sales Tax (DST) based on 3% gross revenue, followed by

2. a longer-term approach addressing taxation of profits when a company has no physical presence in a country.

To date the EU has not managed to get unanimous agreement from member states and the above proposals have been delayed. However, this has led to individual EU member states moving forward with their own DSTs. Austria, Belgium, France, Italy, Spain and the UK are all in the process of moving forward individually in this respect.

Non-EU countries are also considering ways to tax the digital economy. In October 2018, Australia issued its own discussion paper, followed by New Zealand in February 2019, on how to tax the digital economy. However, to date nothing has been implemented. Governments are wary of introducing a patchwork of similar but different measures.

For now building an entirely new tax system around blockchain is not realistic – we need to start small and look for the human problems that need to be solved. We are in the early stages of understanding how and what blockchain can do for businesses, for consumers and for the world of tax. Similarly tax is not the main priority when businesses think about using blockchain. Although the focus is blockchain's potential to reduce transactional costs, add digital trust and improve transparency, a resulting more streamlined, efficient and effective tax function would be a significant bonus.

In conclusion, as our businesses migrate more and more onto digital platforms with tax authorities likely to follow, there will be some interesting dilemmas for the regulators. Should they accept digital currencies such as Bitcoin for the payment of tax? As more artificial intelligence and machine learning perform routine employment tasks and gradually replace human workers, then should a robot tax be introduced? How should governments tax the digital natives who work across borders and receive payment for their services in digital currencies?

Even though blockchain is lauded as a revolutionary technology that will impact every industry, and may address some of the above concerns, to be truly transformative on a global scale, then the real advantage will come from a unified global financial platform that companies can 'plug and play' into. This will raise all kinds of national sovereignty issues. As such this would appear some way off in the future. For now, continued investment in this technology and application of wider tax-use-case examples can help speed up the mainstream acceptance and adoption of blockchain.

*This article was first published in the June 2020 edition of CSJ, the official journal of the Hong Kong Institute of Chartered Secretaries ([www.hkics.org.hk](http://www.hkics.org.hk)). Republished with permission.*



# Do Directors Prepare Well for Board Meetings?

## ■ Paul Geyer

Director, VUCA Trusted Advisors

- Thirty per cent of directors surveyed believe their colleagues are not adequately prepared.

- Thirty-two per cent of directors the papers are sent too late.

- Ten per cent of directors are undertaking additional research and reading due to the poor quality of the board papers.

There are many factors that underpin good decision making around the board table. One that receives little attention is how individual directors prepare for meetings. VUCA Trusted Advisors undertook a research project engaging with directors to gain a greater insight into how directors prepare for board meetings. The directors who participated were experienced with 75 per cent having two or more board positions and 85 per cent were professional (paid) directors.

The topic was initiated by a letter from Martin Kriewaldt, chair of Central Petroleum in the *Australian Financial Review* (4 October 2019) that stated that ‘the rule of thumb is that one reads board papers three times before a meeting, with some days between to allow for reflection’. While reading papers is clearly essential there are other components to preparation that underpin good decision making, such as additional research and preparation, seeking external advice, raising issues with the chair, clarifying or seeking further information from the CEO or executive team, testing thinking with fellow directors, reflecting and ideation or innovative thought.

The results were positive, with 90 per cent always reading their board papers. We gained some insights to why the 10 per cent don’t always read their papers and why papers aren’t read multiple times. There was diversity with how deeply papers were read.

Nearly a third of directors are reading their board papers once and only 5 per cent achieve Martin Kriewaldt’s standard of reading three times. Positively over 40 per cent are reading the important papers multiple times.

**Do you read the papers in the agenda pack? (select 1 only)**

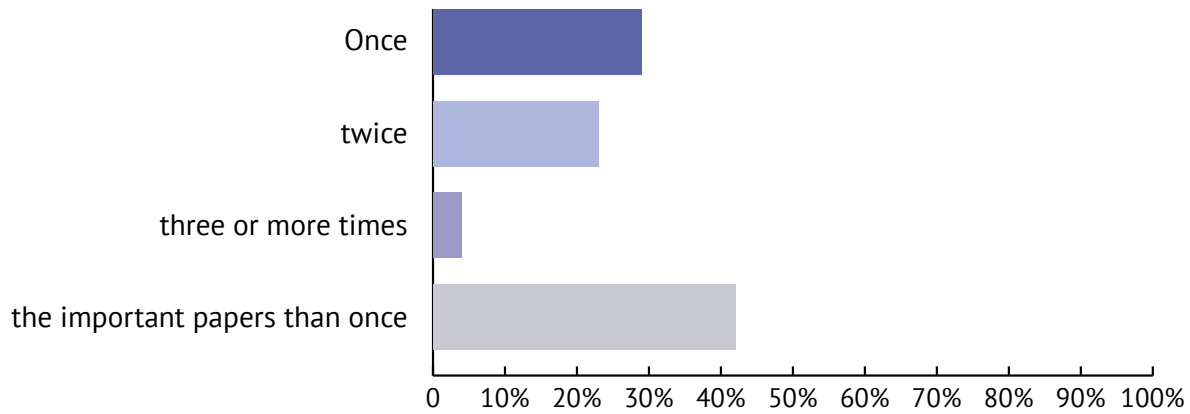

If preparation is key to good decision making and it clearly is with 75 per cent strongly agreeing with the statement ‘Thorough reading and understanding of the board papers contributes to robust discussion and informed decision making within board meetings’. Interesting, 30 per cent

of directors in our study believe their colleagues are not adequately prepared. So, what is holding directors back from adequately preparing? The study identified the crucial factors that impact on director’s preparation, ranked in the figure below.

**Overall, which factors do you feel are the most crucial to ensuring board members are prepared for board meetings and can fulfill their duty as a board member. (Rank 1-4, with 1 being the most important factor)**

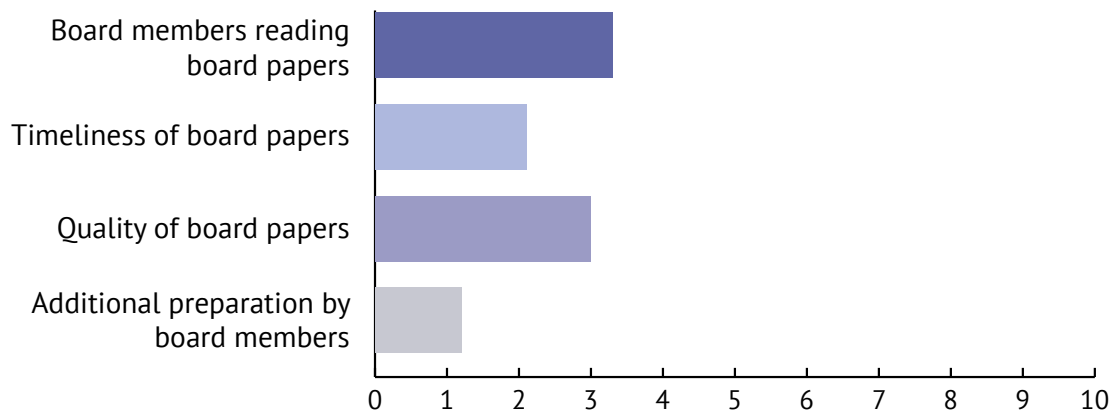

### Too busy

Eight per cent are too busy to read the whole pack. However, if you are too busy to fulfil your legal and professional obligations you need to consider, is this a short-term issue or if you should resign (Queue strains of *Should I stay or should I go* by The Clash). Don't be

naïve, your colleagues know you are not prepared.

### Poor quality papers

Fourteen per cent claim it is due to the poor quality of the papers. Analysing this further, directors are underwhelmed with the quality of papers:

**The board papers consistently provide the relevant data, information and analysis I require to inform decision making?**

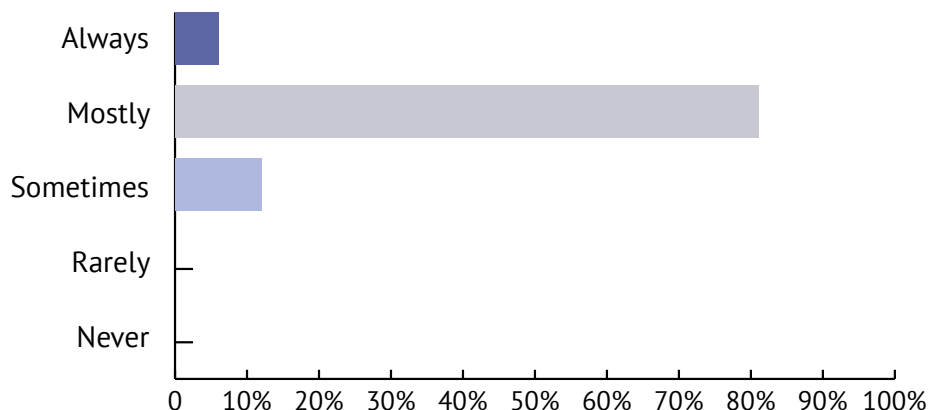

The results show 10 per cent of directors are undertaking additional research and reading due to the poor quality of the board papers. Boards need to discuss and set the standard for board paper format and content and chairs need to discuss the board's expectation with their CEO. CEOs and company secretaries need to discuss information needs for important agenda items in advance of paper preparation so that the breadth of the issue is fully canvassed. For some important decisions understanding the information needs for good decision making is best done in prior meetings with the whole board. 'Major decisions should be preceded by presentations in the prior board meeting to ensure board has had opportunity to question exec and ensure all questions are answered in the decision report.'

### Late papers

For 32 per cent of directors the papers are sent too late (too close to the meeting) to have time to read them. Looking at this in detail it is concerning that the accepted standard of seven days prior to meeting is only experienced by 49 per cent of directors. Alarming 38 per cent of directors receive their papers three or less days prior to their board meeting.

This is not best practice and it highlights why 30 per cent of directors are only reading their papers once. Chairs need to set clear expectations with CEO, company secretary and executive team that board packs are to be sent 7 days prior to board meeting. With sufficient time directors can undertake additional preparation, research, seek external advice, clarify or seek further information from the CEO, avoid group think, test for unconscious bias and reflect on the content.

**Do you receive your board papers (please tick those that apply for your various board positions)**

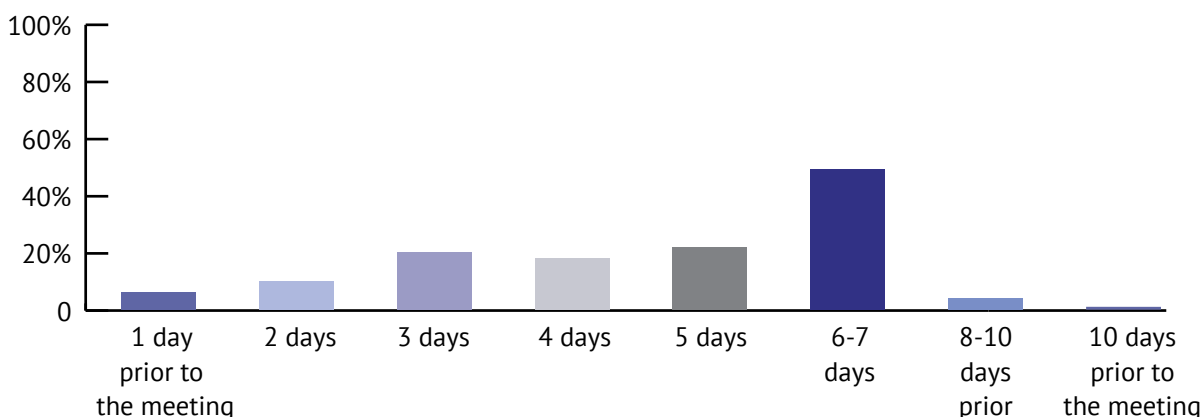



End of meeting reviews are not impacting on issues such as late papers. For 40 per cent of directors their agendas include an end of meeting review but only 18 per cent directors believe this makes a regular difference and for 19 per cent it never does. 'The attitude of the chair, ie, Does the chair drive the right behaviours and ensure papers are delivered a week prior and are relevant?'

As an aside nearly 30 per cent of directors are receiving their papers in hard copy. This is the most time consuming and expensive method of compiling and distributing papers. If you are receiving papers late consider moving to electronic delivery (email password protected document or shared drive or board app) which would speed up receiving the papers by one or two days.

### Additional preparation work

Directors do work hard. 96 per cent undertake additional reading or research on topics in the board papers. Over 25 per cent do this with some consistency. Alongside this, directors also regularly review past board papers with 60 per cent doing this sometimes and 10 per cent consistently.

#### Do you undertake additional research or reading on topics in the board papers?

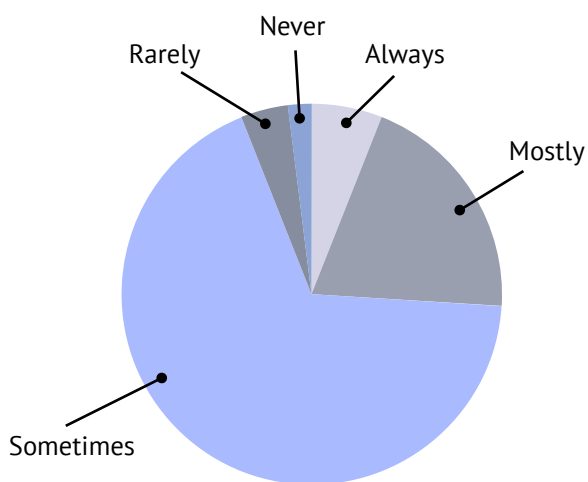

There are many reasons why directors undertake additional reading the most common (60 per cent of directors) is 'Self-directed learning to increase your own knowledge'. The feedback goes to heart of preparing for good quality decision-making:

- 'Assist in formulating thoughts around the issue at'
- 'Checking to ensure consistency in the information or refreshing my'
- 'Additional research for me is usually analysis I think is needed to reach a decision/offer constructive input but which is missing from the (Many papers are more descriptive than analytical.)'

- 'Decision reports that are critical to the business deserve background'
- 'Seeking alternative perspective and or'
- 'I am presenting new ideas or diverse perspectives and I deliver these with'
- 'Inform myself so I can form my own view and not solely rely on management's'

Directors also contact the chair, fellow directors and the CEO or executives as part of their preparation with 45 per cent doing this sometimes. While testing your own thinking can be beneficial some caution is required with this to ensure the information provided is also available to all directors and that you are not engaging in lobbying for your position. 16 per cent of directors regularly contact the chair or other directors. There is a risk with this behaviour that decisions are being made or positions are being framed outside of the openness of the boardroom which can lead to factions and dysfunctional boards.

### Conclusion

Thoughtful director preparation underpins board decision making and innovative thinking. It is aided by reading the papers multiple times, having time to reflect, quality of the board papers, having sufficient time to undertake additional reading and research. Two factors that impinge on preparation – papers sent late and quality of papers – are in the hands of chairs and boards to address. In the volatile, uncertain and ambiguous world directors operate in, preparation is critical to good decision making.

Feedback from directors also highlights:

- Preparedness to listen to any additional information or views, focus on what it is the organisation wants from the board i.e. quality recommendations that are specific in time and scope.
- The biography of board members, their breadth of experience and their developmental stage, for example, the ability to hold complexity and ambiguity and remain mentally agile and creative.

*This article was first published in the July 2020 edition of Governance Directions, the official journal of the Governance Institute of Australia ([www.governanceinstitute.com.au](http://www.governanceinstitute.com.au)).*

*Reprinted with permission.*

# To Whom Does the Company Secretary Owe a Duty of Care?

■ **Kenneth Foo Poh Khean** FCIS, LL.B (Hons), CLP, CGP



## **Duties of company directors**

Generally, a director of a company incorporated under the Companies Act 2016 (“the Act”) owe the following general duties to the company and shareholders –

1. a duty to exercise his powers in accordance with the Act for a property purpose and in good faith in the best interest of the company - subsection 213 (1);
2. a duty to exercise reasonable care, skill and diligence with the knowledge, skill and experience which may reasonably be expected of a person having the same responsibilities and any additional knowledge, skill and experience which the person in fact has – subsection 213(2);
3. a duty to exercise business judgement in the best interest of the company without any material personal interest – subsection 214(1);
4. a duty to exercise independent judgement even though there is information, opinions, reports or statements prepared by professionals or experts – section 215;
5. a duty to avoid any conflict of interest whereby he gains a benefit for himself or any other person by reason of information acquired by him as a director or his position or any opportunity which he becomes aware of – subsection 218(1); and



6. a duty to declare the nature of an interest in a contract or proposed contract with the company whether the interest is direct or indirect – subsection 221(1).

Pursuant to Section 210 of the Act, some of the duties mentioned above extend to other company officers, namely, the chief executive officer, chief financial officer, chief operating officer or any other person primarily responsible for the management of the company. It can therefore be said that these duties do not apply to a company secretary unless his terms of appointment and/or service makes him a person who is primarily responsible for the management of the company.

The Act seems to have imposed only one statutory duty on the company secretary under subsection 102(1) which requires the person to keep the register of members properly and maintained it regularly and to enter all the particulars on issuance and transfer of shares into the register.

However, with the implementation of Section 241 of the Act, the duties of a company secretary have now been expanded through the “*Guidelines Relating to Practising Certificate for Secretaries under Section 241 of the Companies Act 2016*.” (“the Practising Certificate Guidelines”). There are two paragraphs in the Practising Certificate Guidelines dealing with duties of the company secretary which is enumerated as follows –



Paragraph 27 requires the company secretary to –

- a) be present at the registered office of the company on the days and at the hours during which the registered office is to be accessible to the public;
- b) maintain and keep updated all the registers, records and books which are required to be kept at the registered office; and
- c) provide the statutory documents within specific time as requested by any person who is entitled to inspect such document and records at registered office.

Paragraph 28 requires the company secretary at all times to act honestly and use reasonable diligence in the discharge of his duties as a secretary while his duties may include, but not limited to the following:

- a) manage, attend and record the proceedings of the meetings of the board of directors;
- b) manage, attend and record the proceedings of the meetings of shareholders;
- c) manage the processes relating to the passing of resolutions of the board of directors and of the company;
- d) advising the board of directors on statutory requirements under the CA 2016 and other disclosure and governance requirements relevant to the company;
- e) ensure the statutory documents and records to be provided to the new company secretary or company at the registered office once he ceased office as company secretary; or
- f) any other duties imposed under the Act.

In carrying out and discharging such duties whether as a director or a company secretary, does the person owe a duty of care to other company officers?

### Doctrine of duty of care

The doctrine of duty of care was laid down in the case of *Donoghue v Stevenson* [1932] by Lord Atkin who held that a general duty of care could be said to exist between two parties under the 'neighbour principle', described in this key quote:

“You must take reasonable care to avoid acts or omissions which you can reasonably foresee would be likely to injure your neighbour. Who, then, in law, is my neighbour? The answer seems to be - persons who are so closely and directly affected by my act that I ought reasonably to have them in contemplation as being so affected when I am directing my mind to the acts or omissions which are called into question.”

To put it in another way, a duty of care is a legal duty to take reasonable care not to cause harm to another person that could be reasonably foreseen. This means that a duty of care does not arise in all circumstances as there must be reasonable foreseeability that a particular person might be injured or harmed if you act or behave with a lack of care.

A duty of care is breached when:

- a person is injured because of the action (or inaction) of another person; and
- it was reasonably foreseeable that such action (or inaction) would result in a risk of injury to the injured person; and
- the action (or inaction) causing the injury was unreasonable. This means that a reasonable person in the same position would not have acted in that way; and
- the risk of injury occurring was not an insignificant risk.



As Lord Atkin's description of the neighbour principle was relatively broad in scope and could be inclusive of a wide range of situations, subsequent cases tried to limit the scope of application until the House of Lords in the case of *Caparo Industries PLC v Dickman* [1990] set out a "three-fold test" for a duty of care to arise in negligence:

- harm must be reasonably foreseeable as a result of the defendant's conduct (as established in *Donoghue v Stevenson*);
- the parties must be in a relationship of proximity; and
- it must be fair, just and reasonable to impose liability.

In the *Caparo* case the auditors were sued on the basis that they owed a duty of care to investors and potential investors in respect of the audit and certification of the accounts. The House of Lords held that the auditor did not owe any duty to an investing member of the public as the auditor's duty of care was only to shareholders in which there was a relationship of proximity.



The leading case on negligent misstatements before the *Caparo* case was the case of *Hedley Byrne v Heller* [1964]. In *Hedley Byrne's* case, the bankers were asked on the financial stability of a customer of the bank and they gave a favourable reference. Acting on the bank's reference, the plaintiffs extended credit to the bank's customer who defaulted on the credit. The House of Lords in *Hedley Byrne's* case held that when a person makes a statement, he voluntarily assumes responsibility to the person he makes it to (or those who were in his contemplation). If the statement was made negligently, then he will be liable for any loss which results.

### **A director's duty of care to other directors**

Arising from the 3 cases as discussed, does a company director owe a duty of care to his fellow directors in the company?

If we look at *Donoghue v Stevenson* and *Caparo's* case, there is certainly a close proximity between directors. However, in the case of a company director, I would assert that he owes a duty to the Board of Directors and not to individual fellow directors. Subsection 211 (1) provides that the business and affairs of a company shall be managed by, or under the direction of the Board. This means a director cannot act on his own unless the company has only one director. Decisions are either through a majority vote at board meetings or by the passing of a written resolution signed by all directors.

For example, Paragraph 9 of the Third Schedule to the Act provides that every director shall have one vote in board proceedings. This means board decisions are based upon a majority decision making process. Thus, in the event a director acted negligently, it is unlikely that he can be sued by another fellow director for owing a duty of care to that fellow director. He may be liable to the Board and the company but not to another fellow director.

In *Caparo's* case, Lord Bridge in laying down the tests stated that –

“First one has to ask whether, as between the alleged wrongdoer and the person who has suffered damage there is a sufficient relationship of proximity or neighbourhood such that, in the reasonable contemplation of the former, carelessness on his part may be likely to cause damage to the latter – in which case a prima facie duty of care arises. Secondly, if the first question is answered affirmatively, it is necessary to consider whether there are any considerations which ought to negative, or to reduce or limit the scope of the duty or the class of person to whom it is owed or the damages to which a breach of it may give rise.”

It cannot be denied that there is a sufficient relationship of proximity between fellow directors but in terms of damages suffered, the rightful party who suffered would be the company and/or the Board, not a fellow director. So even if the first question is answered affirmatively, what scope of duty does a director owe to another fellow director? Unless there is a decided case on this, the answer to this question is that a director does not owe any duty of care to another fellow director.

### **A company secretary's duty of care to the board of directors**

Does a company secretary owe a duty of care to the Board of Directors when carrying out and discharging his duties? Or does the company secretary owe a duty of care to each individual director?

Since subsection 236(1) of the Act provides that the Board shall appoint a secretary and determine the terms and conditions of such appointment, it is submitted that the company secretary owes a duty of care to the Board and not to each director individually and personally. The appointment is based on a collective/majority decision of the Board and not by any one single director. Therefore, the duty of care is only to the Board.

In addition, the power to remove a company secretary is by the Board as provided under Section 239. This means a collective/majority decision of the directors. Last but not least, a company secretary's notice of resignation is only effective if it is given to the Board under subsection 237(1). It will not be effective if it is just served on one director, unless the Board consist of only one director.

### **Standard of duty of care**

*Donoghue v Stevenson* laid down the doctrine of duty of care. What is the standard of that duty? According to Lord Atkin, a person must take "reasonable care to avoid acts or omissions which you can reasonably foresee would be likely to injure your neighbour". Reasonable would depend on the circumstances and facts as it may differ from case to case.

For a company secretary, Paragraph 28 of the Practising Certificate Guidelines require the person at all times to "act honestly and use reasonable diligence" in the discharge of his duties as a secretary. In this aspect, "reasonable diligence" would probably be similar to the duties imposed on a director under subsection 213(2). That means the company secretary must carry out his duties with the knowledge, skill and experience which may reasonably be expected of a person having the same responsibilities and any additional knowledge, skill and experience which the person in fact has.

### **Professional liability**

In view that MAICSA members are persons who have undergone a rigorous examination process and the required skill and experience to be recognized as a chartered secretary, the duty to use reasonable diligence could be on a higher standard compared to other company secretaries.

Company secretaries therefore should seriously look into acquiring a professional indemnity insurance policy (PII) to protect against his legal liability to pay damages to persons who have sustained financial loss arising from his own professional negligence or that of his employees in the conduct of the business. The PII offers indemnity strictly on legal liability basis and in addition to indemnifying the professional against his professional liability. It also indemnifies him for legal cost and expenses incurred in respect of a claim.

### **Continuous professional development**

Other than acquiring a PII, a company secretary should look towards enhancing his skills and knowledge through the attendance of continuous professional development programs and seminars conducted by MAICSA which are prepared for their benefit and avoid committing errors or omissions which another company secretary would not have committed.

### **Conclusion**

In conclusion, a company secretary owes a duty of care to the Board of Directors but not to a director personally or individually. That duty must be carried with reasonable care, skill and diligence and cannot be taken lightly or carelessly. Only with such display and exercise of a high standard of duty can the company secretary earn the respect of the Board of Directors and gain the recognition he deserves.

*This article was first published in the April-June 2020 edition of Corporate Voice, the official journal of The Malaysian Association of Chartered Secretaries and Administrators (MAICSA) (www.maicsa.org.my). Reprinted with permission.*



# Breathing Space

## ■ Peter Swabey FCIS

Policy and Research Director at ICSA:  
The Governance Institute

The Corporate Insolvency and Governance Act has made the biggest reforms to the UK's insolvency framework for almost 20 years, as well as some significant changes to corporate governance law.



On 26 June, the Corporate Insolvency and Governance Act received Royal Assent. It is a complex measure, not only making the biggest reforms to the UK's insolvency framework for almost 20 years but also making some significant changes to corporate governance law to reflect the needs of companies and other organisations during the COVID-19 pandemic.

The main focus of the Act is the provisions around insolvency, and we do not have room to go through

these in detail here. The intention is, in the words of the explanatory memorandum, to “introduce greater flexibility into the insolvency regime, allowing companies breathing space to explore options for rescue whilst supplies are protected, so they can have the maximum chance of survival; [and] to temporarily suspend parts of insolvency law to support directors to continue trading through the emergency without the threat of personal liability and to protect companies from aggressive creditor action”. Principal elements of the Act include:

- **Moratorium.** The introduction of a moratorium allowing a company in financial distress a breathing space in which to explore its rescue and restructuring options free from creditor action, perhaps facilitating a rescue of the company.
- **Arrangements and reconstructions for companies in financial difficulty** – provisions which will allow struggling companies, or their creditors or members, to propose a new restructuring plan proposal between the company and creditors and members.
- **Winding-up petitions** – provisions to protect businesses from winding-up petitions by creditors in circumstances where COVID-19 has had a financial effect on the company which has caused the grounds for the proceedings.
- **Wrongful trading** – a measure to prevent a court taking into account losses incurred during the period in which businesses were suffering from the impact of the pandemic when assessing director liabilities.
- **Termination clauses in supply contracts** – the prohibition of termination clauses that engage on insolvency or are based on past breaches of contract, which will mean that (subject to certain exclusions) contracted suppliers will have to continue to supply, even where there are pre-insolvency arrears (unless they can demonstrate that this will cause them financial hardship).

Some of these changes are time limited, but others make permanent changes to UK insolvency law and, as such, they were the subject of detailed discussion during their passage through parliament. A webinar on the insolvency aspects of the Act, which the Institute ran jointly with a number of accountancy and insolvency regulating bodies is available at: [r3.org.uk/events-training/webinars/more/29479/page/1/](https://www.r3.org.uk/events-training/webinars/more/29479/page/1/).

Leaving aside the significant changes to insolvency regulation, the corporate governance changes constitute nothing less than a significant erosion – albeit temporary and very necessary – of shareholder rights enshrined in the articles of association. The principal changes can be found in Schedule 14, which relates to ‘meetings of companies and other bodies’.

### Covering all bases

The scope of the Act is wide – it covers companies, charitable incorporated organisations, registered co-operative societies, building societies and friendly societies (as defined in specific legislation) and applies to meetings held, or due to be held, between 26 March and 30 September 2020 with power for national authorities (the Secretary of State or relevant devolved bodies) to amend the period as necessary or to make additional regulations. The legislation provides that:

- ‘The meeting need not be held at any particular place’ – which removes the need for a venue to be stated and so has the effect of removing any doubt about the legality of virtual meetings.



- ‘The meeting may be held, and any votes may be permitted to be cast, by electronic means or any other means’ which permits a wide range of options, including virtual meetings.
- ‘The meeting may be held without any number of those participating in the meeting being together at the same place’ which removes the requirement for a quorum meeting together.
- ‘A member...does not have a right – (a) to attend the meeting in person, (b) to participate in the meeting other than by voting, or (c) to vote by particular means’ which establishes that meetings can be held electronically and behind closed doors.
- ‘The provisions of any enactment relating to meetings’ and ‘The provisions of the constitution or rules of the qualifying body have effect subject to this paragraph’ which means that this Act overrides any conflicting provision in legislation, regulation or the organisation’s own constitution, including its articles of association.

Finally, the Act extends the period in which an AGM must be held until 30 September 2020, with power for the ‘national authority’ to extend this if necessary. These are clearly non-trivial changes, removing the right of members to attend an AGM (even though it would be illegal under the current restrictions on gatherings for them to do so) and overriding the terms of the articles of association, which back all those years ago when I was studying for my exams (the Companies Act 1985 thank you, not the 1948 Act!) was treated as the contract between a company and its members.

### Further changes

There are further changes in the Act around company filings, typically giving extended time limits for documents to be filed at Companies House and, importantly, extending the period allowed for the delivery of the annual report and accounts to Companies House to either 30 September 2020 or “the last day of the period of 12 months immediately following the end of the relevant accounting reference period”, whichever is the earlier. A webinar on the governance aspects of the Act, which the Institute ran jointly with a number of accountancy and insolvency regulating bodies is available at: [icsa.org.uk/knowledge/webinars/corporate-insolvencyand-governance-act-2020](https://www.icsa.org.uk/knowledge/webinars/corporate-insolvencyand-governance-act-2020).

The Institute, with the help of Slaughter and May, updated its guidance on shareholder meetings to reflect these changes and Shareholder meetings under the Corporate Insolvency and Governance Act 2020 was published on 9 July 2020. The new guidance has been drafted by a Working Party of the City of London Law Society Company Law Committee and the Chartered Governance Institute, with the support of GC100 – the Association of General Counsel and

Company Secretaries working in FTSE 100 Companies, the Investment Association and the Quoted Companies Alliance. The Department for Business, Energy and Industrial Strategy and the FRC have both endorsed this guidance note, which covers a number of issues, including how companies can hold shareholder meetings under the Act and how they can balance the rights of members against the need to comply with lockdown requirements.

On 4 July, the Health Protection (Coronavirus, Restrictions) (No.2) (England) Regulations 2020, (the Regulations) took effect and increased the number of people that can meet for a physical meeting. Companies with an AGM before 30 September are protected by the Act, but the Regulations create concern for a number of companies due to hold their AGM after that date and who are currently developing their documentation in order to give appropriate notice. Although the Regulations require conference venues to remain closed, many other business premises may now be opened and it is conceivable that the situation will have changed further by the end of September. In this case, as the law stands, it might be necessary for companies to hold a physical AGM, albeit that they must be held in accordance with the then current government guidance on social distancing at a venue which is not required to remain closed. There are at least six FTSE 100 companies which fall into this position and I am sure that there will be many more outside the FTSE 100. I have therefore written, with the support of a number of other organisations, to the Department for Business, Energy and Industrial Strategy asking them to extend the provisions of Schedule 4 of the Act until the end of the year, and to do so as soon as possible given the planning timeline for the average AGM and the fact that a number of firms have reported that they are already advising clients on meetings in Q4. This will give the affected companies, and their shareholders, greater certainty.

One message that came through very clearly in our webinar with Sacha Sadan, Director of Investment Stewardship at Legal & General Investment Management, on 29 June was that, although investors believe that investee companies should put their stakeholders first during the COVID-19 crisis, they are watching keenly to see how companies behave. And behaviours will have consequences. Investors will support companies during this difficult time, but also hold them to account. Issues such as tax transparency, capital management, diversity, over boarding, data security and climate change will remain important, and companies will, rightly, be judged on how they respond to the conflicting challenges facing them. Good governance and sustainability will be the building blocks of a better future.

*This article was first published in the August 2020 edition of Governance and Compliance, the official journal of ICSA: The Chartered Governance Institute ([www.icsa.org.uk](http://www.icsa.org.uk)). Reprinted with permission.*



# Independent Directorship: Have you Got What it Takes?

■ **Kieran Colvert**  
*CSj* Editor

Since retiring two years ago, Richard Ho FCIS FCS, has embarked on a second career as an independent non-executive director (INED). He shares with *CSj* some essential lessons in how to make a success of the INED calling.



**Richard Ho** FCIS FCS



**Can you tell us about your personal background and career path?**

'I studied for the examinations of The Institute of Chartered Secretaries and Administrators (ICSA – now The Chartered Governance Institute) full time at Hong Kong Polytechnic (now The Hong Kong Polytechnic University) in the 1980s. After I graduated, I found a job in a bank and I stayed in banking until I retired.'

**Was the ICSA training useful to you in your career?**

'Yes, I haven't worked specifically as a Chartered Secretary, but the training provided me with a good foundation for my career. The training covers everything from accountancy and business law to administration. Accountancy was obviously useful, as a banker you need to be able to analyse

balance sheets, but the business law aspects were just as useful since that background gave me confidence to advise customers on regulatory issues. There are courses specifically designed to give formal training to bankers, but I think the ICSA training was equally good, because it gave me an across-the-board awareness of many different aspects of business.'

**Can we turn to your second career as an INED since your retirement two years ago?**

'I was 60 years old when I retired, so I was looking for something I could do. I was approached by some of my business friends to join a board as an INED. That was an interesting option for me. It's not a full-time job, but I felt that it would be a way for me to maintain my connections with the business world.'

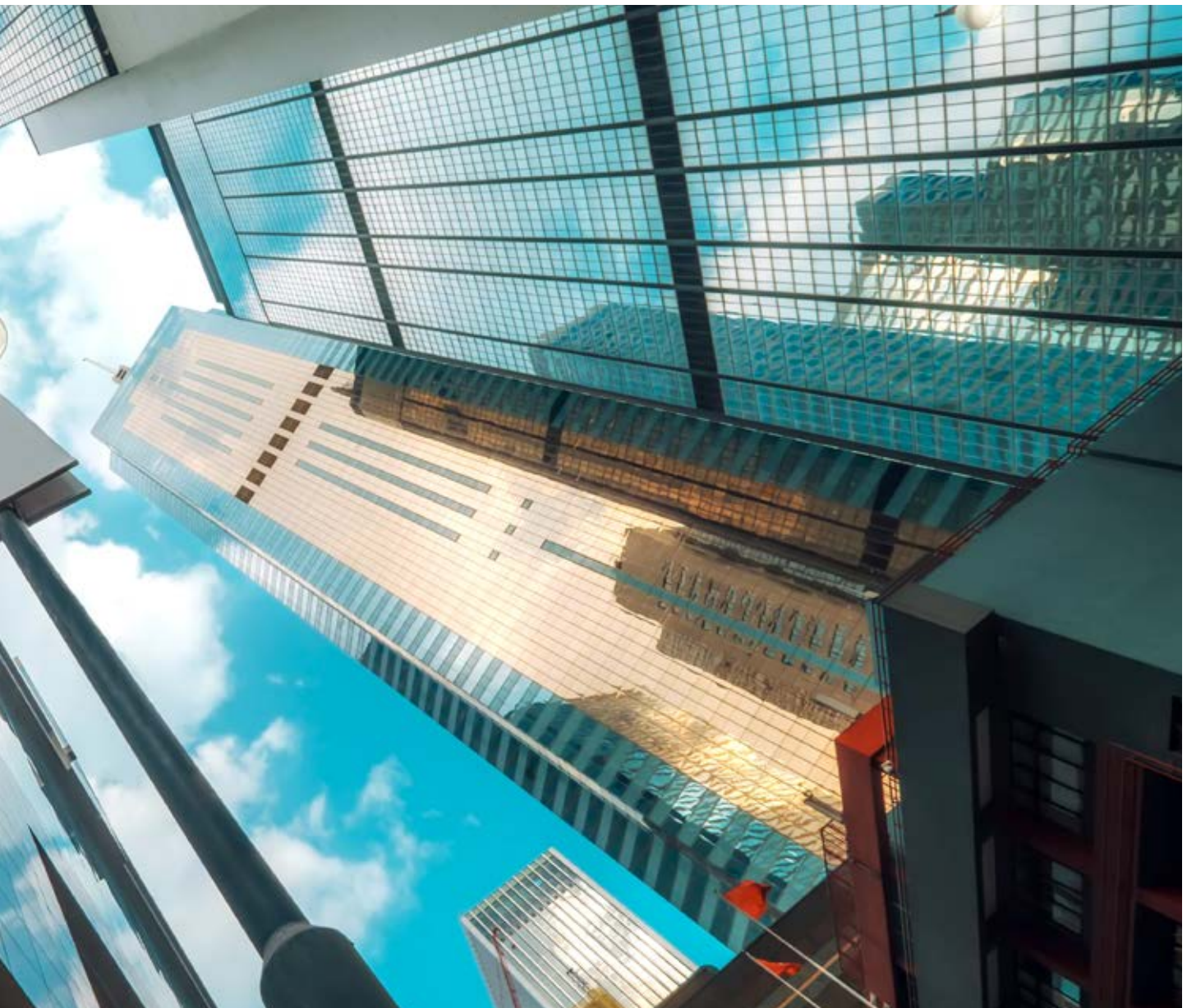



I can't claim to be an experienced INED. I started this work only one-and-a-half years ago, but I have had the benefit of being a committee member of The Hong Kong Institute of Directors (HKIoD) Directors of the Year Awards. I joined HKIoD to learn more about how to be a director and I was asked to join the committee running the award. The award celebrates directors who excel in corporate governance, those who serve as role models for what directorship is really about, so this has been an interesting and eye-opening experience.'

**You mention that working as an INED is not a full-time job – have you been surprised by the amount of time it takes?**

'People used to think that being invited to join a board as an INED was an honorary position. They assumed it wouldn't occupy much of their time and that they could be very passive. Over the last decade, expectations have changed a lot. The requirements of the listing rules and the Companies Ordinance are much more explicit about the need for directors to maintain an active interest in the affairs of the company.

The fact is, to be effective in the INED role, you need to understand every aspect of the company and the wider business environment. You cannot be passive, you have to be proactive and diligent in doing your duty as a director. This does not only mean spending the time needed to understand the business and attend meetings, it is also about having the courage to speak up if something doesn't seem right.

Board and board committee meetings should not be regarded as a formality, held in the interests of conformance with the listing rule requirements. Compliance is essential of course, but directors are not there just to ensure conformance but to improve performance. That means effectively developing the company's business strategy and effectively monitoring the performance of management. So signing up for a director's role is not a decision to be taken lightly. You may have to be controversial because you are the watchdog on behalf of all the stakeholders.'

**You mention that expectations have changed – have attitudes among independent directors also changed in line with these expectations?**

'I think awareness is improving. Part of the credit for this should go to the many bodies in Hong Kong that are promoting better professionalism among directors. The Securities and Futures Commission (SFC), Hong Kong Exchanges and Clearing Ltd (HKEX), the HKIoD and The Hong Kong Institute of Chartered Secretaries have focused on the importance of directors understanding their duties and responsibilities.'



**What advice would you give to someone thinking of joining a board as an independent director?**

'The first thing I would emphasise is that the Companies Ordinance doesn't differentiate between executive and non-executive directors – all directors share the same legal responsibilities and liabilities, and they share the same fiduciary duties towards the company and its stakeholders.

Management's job is to run the company and your job as a director is to oversee management, so when you accept a seat on a board, you are accepting this challenge. If you take on the INED role without really understanding your responsibilities you might be in for an unpleasant surprise. There are cases of serious malpractice in companies and, when it comes to light, you often hear the directors complain that they were not properly informed, or that they were deceived by management. Alternatively, they may say that they weren't given sufficient time to go through the board papers before meetings, or that they were too busy to go through all of the documents thoroughly. Another common complaint is that there wasn't enough time in the meeting to ask questions.

These are not valid excuses. The Companies Ordinance makes it very clear that directors' duties will be interpreted according to both objective and subjective tests. This means that directors will be held accountable, not only for the knowledge they are known to possess due to their professional expertise and background, but also the general knowledge, skill and experience that may be expected for a reasonably diligent person having taken on the role of the director.

There is an expectation that directors will exercise professional scepticism with regard to the information





supplied by management and will request the information they need to exercise good judgement. If board meetings are too rushed, or you don't have enough time to review the board papers, you should ask the company secretary for more time. Asking for the board papers to be circulated at least five days before the meeting, for example, is very reasonable. It does take time to review all the agenda topics before coming to a meeting so that you will be in a position to have a meaningful discussion.

Directors need to ensure that they are in a position to constructively challenge management. That's why they are on the board. So my advice would be for new directors to always apply a reality check to what they are being told. That is not disloyal – directors are supposed to be a check and balance as the loyal opposition party to management.'

### **You mention the company secretary – what's your view of the importance of the relationship between the company secretary and independent directors?**

'INEDs, not being employees of the company, rely a lot on the company secretary for the information they need. The company secretary is a bridge between INEDs and the management of the company. So the extent to which INEDs can do their job well depends on how well the company secretaries do their jobs.

I know the companies I work for as an INED quite well – they were clients of mine as a banker. Other INEDs may not be in that position and they may not know much about the business or the industry. In that case, the company secretary is a kind of mentor. They can coach inexperienced directors to ensure that they understand their roles and responsibilities, as well as the latest trends and

developments in the market. With this in mind, the quality of the corporate governance in a company depends on how good its company secretary is. They are key players in keeping directors informed about new corporate governance requirements and what's happening in the market.'

### **Do you think that the existing measures to boost the independence of INEDs in Hong Kong are effective?**

'There are rules saying for example that the previous auditors of a company cannot be an INED for two years after they retire. In my case, as the previous banker of the company inviting me onto their board, I was not able to join for one year after my retirement.

Nevertheless, generally in Hong Kong the chairman, CEO or CFO recruit board members who they know. I don't have figures to hand, but it is still not common for listed companies to use an outside agency to recruit their INEDs. There will be a question mark over the independence of INEDs who are recruited because they are friends of the top management or chair – will they be in a position to be a check and balance? Will they be reluctant to ask difficult questions with a view to being asked to stay on when the next rotation comes around?

These questions are particularly relevant in companies that are still under family control. That is not to say that family run companies are not good companies – some of Hong Kong's most successful companies fall into this category and, as a banker, I would be very comfortable lending them money. Where a family-owned business has been handed down through several generations, the owners are often very good caretakers, reluctant to take on speculative risks just to push up the share price. Family-owned businesses tend to be run by conservative owners whose main priority is to make sure that the company prospers in the long term for future generations of the family. But where the directors are all close friends of the chairman or the CEO, and where the culture is not conducive to directors challenging the chair or CEO in the boardroom, it is even more vital that INEDs understand their roles and responsibilities and the need to exercise independent judgement.'

### **David Webb has suggested that independent directors should be elected by minority shareholders. Do you think that would be a good way boost their independence?**

'That would be a way to boost their independence, but we have to strike a balance between the need for independence and the need to run an efficient board. In the interests of "perfect" corporate governance, you could insist that all listed companies should have an entirely independent board, but would the directors be able to fit in and work efficiently with the chairman and CEO? Such a rule would likely be a disincentive for companies to get listed.'

### **What's your view of the impact on directors of the recent shift to a multi-stakeholder model of corporate governance?**

'Directors should not be focused on the interests of one particular group or individual – whether that is the shareholders, the directors themselves, the CEO or the chairman – they need to make their decisions based on what is good for the company as a whole. The interests of the shareholders and the company are not always aligned – dividend payments are a good example of this. Shareholders are generally keen on increased dividend payments but this year, in the context of the crisis we are facing, I've seen some companies taking the decision not to pay a dividend to shareholders, or to reduce the dividend and reduce the bonus shares issued. This makes sense at a time when companies need to retain funds to prepare for the difficult times ahead.'

### **Do you have advice for company secretaries regarding their board support role?**

'I would recommend company secretaries remind the chairman or the CEO to allocate more time for the discussion of strategic issues at board meetings. There is often a pressure in board and board committee meetings to reach a decision on the agenda items on time. This is a compliance issue – the company may have a tight deadline to decide on its resolutions for the AGM for example, but that sometimes means that strategic issues don't get addressed.

I would recommend that the company secretary set aside time for the board to discuss the company's long-term business plan in the yearly board agenda. The COVID-19 pandemic and the social unrest in Hong Kong should, for example, have prompted discussions at the board level about whether the company's crisis management plans and strategies are effective. If not, the company needs to think about how to revamp these plans for the future. This might not be regarded as urgent, but it will be important in the long run. The company secretary should try to draw up a master schedule for these kinds of strategic issues.

Company secretaries might try to line up all the agenda items to be decided on in one meeting. They might try to organise board committee meetings one after another so that the agenda can be discussed in one day, or even half a day. That often leads to a scenario where the board discusses the urgent issues on the agenda but important aspects of strategy get crowded out because time is so limited.

Another recommendation I would have for company secretaries is for them to arrange whole board training sessions at least once a year. This ensures that all directors receive the same message and everyone is on the same page. It is particularly useful where directors need to

be updated on important changes in the governance or regulatory environment. I would also recommend company secretaries record any dissenting opinions among directors in the minutes of board meetings. The board takes collective responsibility for decisions made, but individual directors may have dissenting views and that should be noted down.'

### **Do you have advice for INEDs at this difficult time for businesses in Hong Kong?**

'I would encourage boards to focus on maintaining high standards of corporate governance, in particular ensuring that their companies remain transparent and accountable to all stakeholders. Times of crisis and major change are a test of our levels of transparency and accountability, but they are also the time when these things become most important.

COVID-19 is affecting the operations of most companies in Hong Kong, not only companies like restaurants and hotels which are in the front line when it comes to the pandemic. The SFC and HKEX recently issued a joint statement, giving advice on how companies should maintain proper disclosure during the COVID-19 crisis. They suggest companies should be making voluntary announcements and I would strongly urge companies to use this route to ensure stakeholders are informed about how COVID-19 is impacting them. They may not be able to quantify too much because no one knows how long this situation will last, but they can discuss their crisis management plans, and what measures are in place to try to safeguard employees' safety and to resume operations.

Some companies may opt to take a wait-and-see approach, but this is not really an option. Stakeholders know that there will be some impact, so if you don't give them any information there will be a loss of trust. Many stakeholders are directly affected by the changes to companies' operations. After Chinese New Year, many factories in the Mainland were shut down, so customers may be worried that companies might not be able to deliver their goods on time. Suppliers may be concerned about the disruption to distribution networks. If companies issue regular updates about the situation, stakeholders will be reassured that the company recognises and is managing the risks involved.'

*This article was first published in the May 2020 edition of CSJ, the official journal of the Hong Kong Institute of Chartered Secretaries (www.hkics.org.hk). Republished with permission.*

## Boardroom ESG: COVID-19, Systemic Racism and Climate Governance

Governance Professionals of Canada will be offering an in-depth look at the current practices and key trends on the topic ESG at its upcoming online conference on: *Governance in the New Decade: The Rise of Boardroom ESG* conference, on Monday, September 14, 2020.

Sponsored by Diligent, Governance Professionals of Canada (GPC) has put together a full-day program that will address timely and important ESG issues and trends, guided by top subject matter professionals, such as keynote speaker Wes Hall, Executive Chairman of KSS Group of Companies and Founder and Chair of The BlackNorth Initiative.

*Governance in the New Decade: The Rise of Boardroom ESG* will kick off with key findings and changes since its first event in 2019. The program will feature discussions on the critical issues of ESG such as: What lessons can boards learn from COVID-19 and the calls for racial justice and Indigenous reconciliation, to improve their governance of social and environmental trends and risks going forward? What new issues are boards facing and why? What can we expect in the coming decade? What are the legal, investor and business cases driving boards to adopt best practices in ESG and climate governance and oversight?

Event partner, CSIA, will also be presenting the findings of its latest survey on *The Role of the Corporate Secretary in Climate Change*, which takes a look at how climate change is managed in different jurisdictions across the globe, with a specific focus on the role of the corporate secretary and governance professional in driving climate change in organizations. The research project aims to get an understanding of the regulatory environment and the extent to which the guidance provided has been adopted by corporates, as well as the awareness of climate change within corporates and the measures they have taken to ensure that accountability is allocated and sufficient capacity exists to embed climate change in corporate cultures.

ESG (Environmental, Social, Governance) is rapidly transforming the dynamics of organizations. COVID-19, systemic racism and climate governance have gained momentum as the hottest ESG topics in the boardroom and it is more important than ever for boards and governance professionals to understand these shifts to adapt to the changing times. The conference is designed to answer many of the key questions that boards and organizations may be facing, such as the following:

- What practices should competent boards have in place to build ESG and Climate Governance in their organizations from the perspective of directors and corporate secretaries?
- How is the rest of the world responding to current issues?
- What are international developments and perspectives on ESG Governance and the implications for Canadian governance?

The event welcomes all sectors and industry participants, governance professionals, board members and leaders who have a key role in their board's oversight and accountability of ESG and climate risks. It is also relevant for investors, owners, and professionals involved in sustainability, CSR, risk, strategy, investor relations, or capital markets who seek to better understand and be on top of this trend. All participants will walk away with insightful perspectives on sustainability, climate governance and corporate social responsibility and the role of the board and governance professional.

The full event agenda can be viewed, [https://gpcanada.org/resources/Documents/ESG%2014%20Sept%202020\\_Event%20Flyer.pdf](https://gpcanada.org/resources/Documents/ESG%2014%20Sept%202020_Event%20Flyer.pdf).

This event is one of the myriad events offered by GPC to put professionals in front of the latest topics in the field of governance and provide the knowledge and resources to equip boards and organizations to conquer the associated challenges. To view more events offered by GPC, <https://gpcanada.org/Events/>.

*For more information on this event and others, please contact:*  
*Crystal Singh*  
*Membership and Events Coordinator*  
*Governance Professionals of Canada (GPC)*  
*21 St. Clair Avenue East | Suite 802 | Toronto, ON | M4T 1L9*  
*T: 416-921-5449 x 316 | 1-800-774-2850 x 316*  
*Email: [crystal.singh@gpcanada.org](mailto:crystal.singh@gpcanada.org) | Web: [www.gpcanada.org](http://www.gpcanada.org)*

*To register or learn more, visit the event page, [https://gpcanada.org/event-3749372?utm\\_source=GGV19&utm\\_medium=link&utm\\_campaign=CSIA](https://gpcanada.org/event-3749372?utm_source=GGV19&utm_medium=link&utm_campaign=CSIA) or contact us at [info@gpcanada.org](mailto:info@gpcanada.org).*

## A Year of Firsts: Society for Corporate Governance Hosts the “First Half” of its National Conference Virtually



When the Society turned the page to the new decade, we never expected that we would also be pivoting our iconic in-person National Conference to a virtual event due to COVID-19. The Society embraced the challenge as a great opportunity to explore new ways of delivering quality content to our members.

*You can't just string together a bunch of webinars and expect to have a successful virtual conference.*

The traditional in-person conference tasks that typically populate the Society's agenda in the several months leading up to the big event were tossed out and a new playbook was created.

Our virtual goals were simple – provide the same high caliber programming as our in-person events and partner with a provider that offered a robust platform, customized user experience, and full-scope technical support for our entire program. Fortunately, since it was already March, our National Conference program topics and many of the speakers for the planned July 2020 in-person event at the Broadmoor in Colorado Springs were already developed. With some topical programming adjustments for racial equality and diversity and COVID-19-related impacts, including virtual

meetings, cybersecurity, communications, and financial reporting disclosure, the initially contemplated 45-session conference program was halved to 23 topics. We then created a four-day schedule that included three one-hour sessions with three tracks that allowed conference attendees to attend the sessions that were of the greatest relevance or interest to them. We decided to run the virtual program live July 7-10, 2020 (deliberately overlapping the dates of our previously planned in-person program because we believed many of our members would already have those dates blocked for our event) and offer it on-demand through the end of September to maximize attendance opportunities.

*Together online or in real life, it's the people, coupled with great content, that makes an event.*

For the benefit of other organizations planning a large-scale virtual event for the first time, here are some pointers based on our experience:

- Select session topics that harness current events and resonate with potential attendees.
- Secure industry experts and relevant keynote speakers.
- Provide a mechanism to offer and promote the opportunity to attain CLE and other professional educational credits.





- Prime your presenters for success with practice sessions that familiarize them with the platform and the technology.
- Schedule the conference start and end times with time zones in mind to accommodate the maximum number of attendees.
- Collect and post on the conference site handouts such as the presentation, articles, and published reports.
- Offer a variety of sponsorship opportunities for organizational partners and exhibitors to engage with attendees.
- Schedule half-hour breaks so that viewers can visit the exhibit hall between sessions.
- Market your message to both typical attendees, as well as those who normally could not attend in person due to travel constraints.
- Position the conference as the best value for the attendee's professional development dollars.
- Pre-conference communications to registrants should include:
  - o How to log in and access the conference
  - o Reminders of the conference dates and times
  - o Communication and disclosure on the platform of how to access real-time technical assistance
- Select a virtual conference platform that offers:
  - o Recording and hosting capabilities for playback on-demand
  - o Video functionality with multiple views of presenters instead of a static webinar screen
  - o A plan for strong customer support and technology redundancy
  - o An engagement tool for sponsors and exhibitors to offer their products and services to attendees
  - o Meaningful social networking opportunities
  - o Question and answer capabilities
  - o The ability to pre-record sessions, especially if the panel is composed of only two people

Our first virtual conference attendance reached nearly 500! Seeking the overall feel and engagement that our typical in-person National Conference embodies, the conference included the chair's morning greeting before the general or keynote presentations, breakouts by company size/type (large-cap, small- and mid-cap or private company), and ample opportunities for online networking. One lesson learned was to build in a little time at the end of each day for a closing by the conference chair.

While we do not know what will happen for the remainder of 2020, we look forward to greeting attendees and welcoming speakers to the "main stage" either in-person or virtually in the future.

Visit [www.societycorp.gov](http://www.societycorp.gov) to learn about membership and upcoming programming.

#### **About the Society for Corporate Governance**

Founded in 1946, the Society for Corporate Governance is a professional association of approximately 3,600 governance professionals who serve 1,200 public, private and not for profit companies of most every size and industry. Its members support the work of corporate boards and executive management regarding corporate governance and disclosure, compliance with corporate and securities laws and regulations, and stock exchange listing requirements.

## HKICS' 21st Annual Corporate and Regulatory Update Conference (ACRU 2020)

The 21st Annual Corporate and Regulatory Conference (ACRU 2020) organised by The Hong Kong Institute of Chartered Secretaries (HKICS), was successfully held in webinar mode on 5 June 2020. This event was well attended by more than 1,900 Chartered Secretaries, Chartered Governance Professionals, chairmen, directors, regulators, other professionals and senior management.

Hong Kong Exchanges and Clearing Limited representatives shared the latest development of a host of governance issues, including enforcement trends and new ESG requirements, which were also the main focuses of the two practitioners sharing sessions that followed.

The Companies Registry revealed the latest requirements of anti-money laundering (AML) and counter-terrorists financing (CTF) for trust or company service providers and

the Hong Kong Business Ethics Development Centre, ICAC shared information on Anti-Corruption and Ethical Governance. The best practices of these regulatory issues are also discussed at the practitioners sharing session in the afternoon. Participants gained a lot of updates and insights from the lineup of top-notch speakers.



Thanks to the concerted support from the Companies Registry; Hong Kong Business Ethics Development Centre, ICAC; Hong Kong Exchanges and Clearing Limited; The Securities and Futures Commission; Speakers; Panel Chairs, Sponsors and Supporting Organisations.

Together, we make the 21st ACRU a huge success in promoting high standard of corporate governance of Hong Kong as a leading financial centre.





# Virtual Governance Professionals Career Day 2020

On 27 June 2020, the Institute held its Governance Professionals Career Day 2020 (Career Day) in virtual mode for the first time, due to the COVID-19 pandemic. This event received an overwhelming response, with over 140 local university undergraduates, Institute students and student ambassadors taking part. The Career Day was designed to provide an overview of who Chartered Secretaries and Chartered Governance Professionals are, as well as their roles and the career opportunities that both professions offer. The event began with welcoming remarks from Gillian Meller FCIS FCS, Institute President, who highlighted the importance of governance professionals in today's challenging business environment and the extensive career prospects.

The Institute was honoured to welcome Ada Chung JP, Registrar of Companies of the Companies Registry, as Guest of Honour. Ms Chung shared her insights on good corporate governance issues and practices with the participants.

The first session – Dialogue with Chartered Secretaries and Chartered Governance Professionals – was facilitated

by Institute member Alice Yiu ACIS ACS(PE). Institute members Mike Chan FCIS FCS, Willa Chan ACIS ACS, Edmund Ng FCIS FCS and Emily Ng ACIS ACS shared their career paths and working experience with the participants. This was followed by an interview with Wendy Ho FCIS FCS(PE), Executive Director, Corporate Services, Tricor Services Ltd, which was facilitated by Institute Registrar Louisa Lau FCIS FCS(PE). The participants also had a chance to e-meet and live-chat with Institute Chief Executive Samantha Suen FCIS FCS(PE). Oliver Williams, an experienced Executive Coach, provided communication tips at work, while Kristy Li from Michael Page, a leading professional recruitment consultancy, gave practical tips for preparing a successful interview. Last but not least, Ms Suen delivered the closing remarks to conclude this meaningful event.

*The Institute would like to thank the Companies Registry and Tricor Services Ltd for being the platinum sponsor, as well as all the supporting universities and higher educational institutions.*





CHARTERED  
SECRETARIES  
特許秘書

Join our  
online  
conference

Registration  
deadline:  
18 September 2020  
[cgc.hkics.org.hk](http://cgc.hkics.org.hk)

# Building the Modern Board: A 20/20 Vision

*Corporate Governance Conference 2020*

**25**  
September 2020  
9.00am–5.00pm

26 September 2020  
ESG in Practice  
(Optional seminar  
incorporating online  
site presentations)

For more information,  
please contact:  
2881 6177  
or email:  
[cpd@hkics.org.hk](mailto:cpd@hkics.org.hk)

Guest of Honour:

The Honourable Christopher Hui Ching-yu JP  
Secretary for Financial Services and the Treasury,  
The HKSAR Government

Platinum Sponsor



Silver Sponsor



Bronze Sponsors



Coffee Break Sponsor





# CSIA e-Magazine Advertising & Technical Specs

“Global Governance Voice” is the quarterly e-Magazine published by Corporate Secretaries International Association Limited (CSIA). With a readership of 70,000 legal, governance, risk, Senior Management and corporate secretary professionals across 70 countries, it is the first international e-Magazine of its type and aims to bring governance topics to the fore, highlighting the challenges faced by governance professionals across the globe. Contributions by in-country experts bring local flavour to global issues, and enable sharing of best practices. Don't miss your opportunity to advertise your organisation or services, and reach more than other publications in this sector!



**Readership: 70,000 governance professionals across at least 70 countries**

Company Name:		Contact Name:	
Company Address: (for Invoice)		Contact Number:	
		Email Address:	

I would like to book the following advert in the CSIA e-Magazine (Please tick as appropriate)

- 1st Full Page – US\$2,420
- 2nd Full Page – US\$2,200
- 3rd Full Page – US\$2,200
- Other Full Page – US\$1,815
- Half Page – US\$1,045

Note: CSIA country member organisations should contact [paul@ninehillsmmedia.com](mailto:paul@ninehillsmmedia.com) for special member association rates.

### Technical Information:

Please provide all art work at 300dpi, PDF, JPG or EPS file. Please ensure that the advert has a 5mm bleed around the whole piece.

Advert sizes:

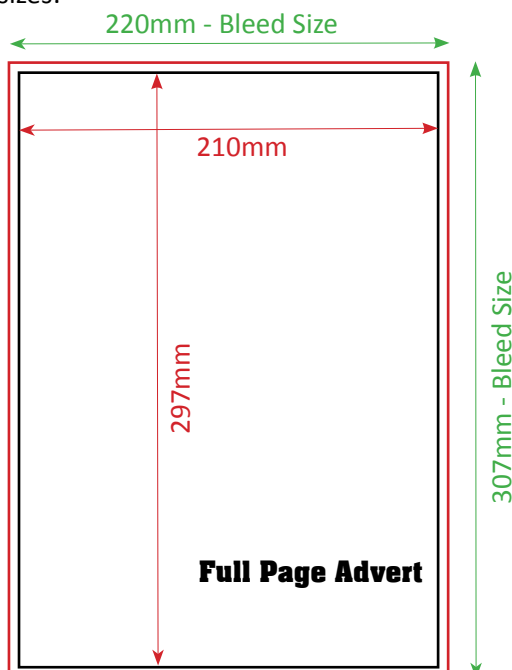

**TO BOOK AN ADVERT, PLEASE COMPLETE THIS FORM, SCAN AND EMAIL TO:**  
[paul@ninehillsmmedia.com](mailto:paul@ninehillsmmedia.com)

### 1/2 Page Advert

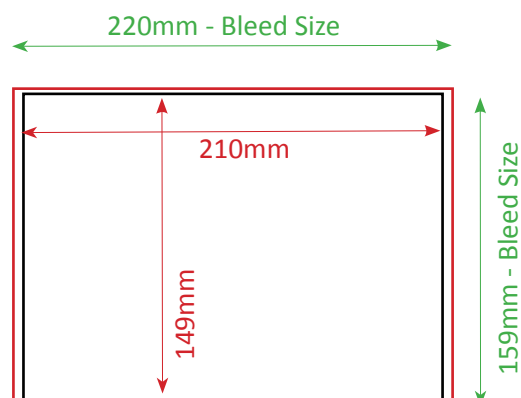

# THE GLOBAL VOICE OF GOVERNANCE PROFESSIONALS



## WHO WE ARE

A *global professional* association consisting of:

# 14 NATIONAL BODIES



We represent more than



# 100 000

corporate secretaries and governance professionals in more than

# 100 COUNTRIES THROUGHOUT THE WORLD



## WHAT WE DO



Promote the **professional status** and **recognition** of corporate secretaries and governance professionals



Advocate for good governance through **research**, thought **leadership** and promoting best **practice**



Create an authoritative, **global platform** of organisations dedicated to the promotion of **good governance**

## WHY JOIN US



1. Reflects your commitment to internationally recognised governance standards;
2. Exposure to the global value created by governance professionals;
3. Access to unique knowledge sharing across 100 countries;
4. Brand recognition in global corporate governance with guidance & benchmarking tools & training;
5. Interaction and access to conferences, speakers, webinars & global training for discounted prices