



The Reliable Source

2007 Catalog

NEWCO - Cast Steel Bolted Bonnet Valves

Gates • Globes • Angles • Swing Checks • Tilting Disc Checks • Stop Checks

Product Line Technical Data



**Corporate Headquarters
Houston, Texas**

1300 Gazin St.

Houston, TX 77020

Tel: 713.675.8631

Fax: 713.675.1589

Toll Free: 800.231.3505

www.NewmansValve.com

Manufacturer of

Newco

COOPER



QuadroSphere

Table of Contents

Introduction	1
NEWMANS History	
Mission Statement	
Company Profile	
Product Technology	
NEWCO Cast Steel Valves Product Applications	2 & 3
Gate Valves OS&Y	
Globe Valves	
Angle Valves	
Swing Check Valves	
Tilting Disc Check Valves	
Stop Check Valves	
Angle Stop Check Valves	
Product Range	4
Valve & Identification Tag Overview	4
How To Order NEWCO Products	5
Body/Bonnet Materials	6
Trim Materials	6
NEWCO Features and Benefits	6
Pressure Temperature Ratings ANSI B16.34 - 2004	7
Flange Dimensions - ANSI B16.5	8
Auxiliary Connection Locations (Bypasses, Drains, etc.)	9
Products & Services	10
VALVES	
Valves	
Manual Operations	
Valve Modification	
AUTOMATION	
Valve and Damper Actuation	
Automation Site Services	
Automation Shop Services	
Controls and Digital Communications	
Cast Steel Bolted Bonnet Valves Dimensional Data and Expanded Views	11 thru 57
Gates..... 2" thru 48" *	Class 150 thru 1500..... 11 thru 17
Globes..... 2" thru 14".....	Class 150 thru 1500..... 19 thru 25
Angles..... 2" thru 12".....	Class 150 thru 600..... 27 thru 31
Swing Checks..... 2" thru 24".....	Class 150 thru 1500..... 33 thru 39
Tilting Disc Checks..... 2" thru 12".....	Class 150 thru 300..... 41 thru 44
Stop Checks..... 2" thru 16".....	Class 150 thru 1500..... 45 thru 51
Angle Stop Checks..... 2" thru 12".....	Class 150 thru 600..... 53 thru 57
* Dimensions in this catalog are through 48", larger sizes available upon request.	
Limited Warranty	58
Applicable Standards	59
American Petroleum Institute (API)	
American Society of Mechanical Engineers (ASME)	
American Society Non-destructive Test (ASNT)	
American Society for Testing and Materials (ASTM)	
British Standards Institute (for reference only) (BS)	
Canadian Standards Association (CSA)	
International Organization for Standardization (ISO)	
Manufacturers Standardization Society (MSS)	
National Association of Corrosion Engineers (NACE)	
Terms and Conditions.....	60 & 61
Definitions	
General Terms and Conditions	
Service Terms	
Branches and Locations	62

Newmans History

Newco Valves, L.P., a Texas limited partnership, dba Newmans, and its wholly owned subsidiary, Newmans Valves, LTD, manufactures, markets and sells Gate, Globe, Check and Ball valves ranging in sizes from 1/4" through 60" ANSI Class 125 thru 4500 lbs. The valves are manufactured to ASME, API and MSS specifications from Carbon (cast and forged), Stainless (cast and forged including Duplex and Super Duplex products), and other alloys (low alloy steels, Inconel, Hastelloy, and noble alloys). "Newco", "OIC" and "Cooper Valves" brand name valves are used in various applications from low pressure processes to specialty applications within the refining, petrochemical, power, pulp and paper, and marine industries. The companies provide both standard product and special designs for their focused industries.

Newmans, L.P., also offers value added services including modifications or actuations and installation of by-passes, bore changes and gear operators for its valves. Some of these modifications include various trim changes covering stems, packing and gaskets, new bolting or changes in the flange surface. In addition, Company operations include marketing, product design, quality control, vendor qualification and value-added services for its product lines.

Timeline

1936: The Company's primary focus was wholesale plumbing and field salvage.

1946: The Company was incorporated under the Newmans name. At that time the focus was changed to the PVF industry until acquired by the Jordan Group in 1989.

1976: Newmans opened its Canadian branch under the name of Newmans Valve Limited.

1984: Precision Actuation Services (PAS) was opened to perform valve modification and actuation services.

1993: In March, Newmans acquired "OIC" and added this trade mark to its business.

1995: Precision Castparts Corporation (PCC) acquired Newmans. The business was operated as a part of the PCC Flow Technologies Division.

2003: On December 26th the business was purchased by the current group of partners that include the original family owners of Newmans.

2005: In June, Newco Valves, L.P., purchased the operations of Cooper Valves from Dresser, Inc., and added specialty alloys and materials to its valve products line.

2006: Newmans opened its Shanghai, China office for service to the Far East market, direct shipments globally and service to the Far East for global project management.

Over the years Newmans has established an excellent reputation for providing a broad product offering from world wide sources at competitive prices and a high level of quality and customer service. The company maintains five (5) stocking warehouse locations in North America and one (1) in Shanghai, China.

Newmans services its markets through a network of distributors and direct sales personnel. The Companies utilize the Infor Commerce@Work (C@W) information system. Commerce@Work is a fully integrated system allowing all Newmans' facilities to operate in an integrated and efficient manner.

Mission Statement

It is our goal to be known and respected in the Industry as "The Reliable Source" for our extensive knowledge and superior service. Measured by keeping our word, we will deliver quality products on time at a fair value.

We achieve the above dealing with integrity in an open and flexible environment allowing people access to valuable information to make good and timely decisions. We believe that all this can be accomplished yielding great rewards for all involved while maintaining a balance in life.

Company Profile

Newmans is recognized as a global valve manufacturing company providing product to the market on a world-wide basis. The NEWCO, OIC and COOPER trademarks are recognized and respected the world over for their high quality and ability to meet the industry's most exacting standards. Newmans manufactures and markets one of the industry's broadest product lines suitable for most applications and market segments. Newmans is fully committed to engineering excellence and product innovation supported by a highly qualified technical engineering staff. Superior customer service is backed by the inventories of finished valves shipped daily from the five divisions located strategically throughout North America.

Product Technology

Newmans manufactures Gate, Globe, Check, Stop Check, Tilting Disc, Floating Ball, Trunnion Ball, and QuadroSphere Ball valves in a full range of materials, valve styles, and pressure classes. Cast carbon steel and low-alloys, forged valves, cast iron and ductile iron valves are manufactured under the NEWCO trademark. 300 series stainless steel and Alloy 20 are produced and marketed under the OIC trademark. Other exotic alloys are manufactured under the Cooper trademark.

Newmans manufactures and stocks valves in sizes from 1/4" to 60" in diameter and in pressure classes from 125 to 4500 lbs. Larger sizes are available on request.

Newmans facilities operate under ISO 9001-2000 series registration. All valves are compliant to the industry standards of API, ASTM, and ASME. Inspection and testing is maintained throughout the manufacturing process to verify compliance to these standards as well as any specific customer requirements.

Customer service is further enhanced by complete modification and actuation capabilities. This capability allows Newmans to provide rapid deliveries of special valve requirements to meet the customer's delivery needs.

Newco Cast Steel Valves Product Applications

The sole purpose of a valve is to regulate flow throughout a fluid processing/transport system whether it is starting, stopping, throttling, or simply controlling flow rate. Gate, Globe, Angle Globe, Swing Check, Tilting Disc Check, and Stop Check valve configurations are designed to perform different functions within a fluid system. This section is designed to help you determine which Newmans valve will best address your application(s).

Gate Valves OS&Y

Sizes: 2" thru 60" **Class:** 150 thru 1500

Gate valves are ideal for bidirectional, low-friction flow and 100% shut-off. Due to the flow characteristics of the wedge-to-seat design, gate valves should be operated in the full-open or full-close position. Concentrated flow across the seats of a partially opened gate valve risks possible seat damage, therefore throttling is not recommended. Gate valves are utilized in applications where minimum pressure drop is necessary.



Globe Valves

Sizes: 2" thru 18" **Class:** 150 thru 1500

Globe valves are ideal for unidirectional, controlled flow. The flow characteristics of a globe valve is repeatable, consistent, and easy to control at any open position, which makes the design suitable for throttling applications.

Note: If line pressure drops below 20%, cavitation, vibration, noise, may be caused, resulting in hardware damage. If these conditions are likely, consult your Newmans representative for recommendations.

Angle Globe Valves

Sizes: 2" thru 12" **Class:** 150 thru 600

Angle Globe valves are ideal for unidirectional, controlled flow. The flow characteristics of a Angle Globe valve is repeatable, consistent, and easy to control at any open position, which makes the design suitable for throttling applications.

Note: If line pressure drops below 20%, cavitation, vibration, noise, may be caused, resulting in hardware damage. If these conditions are likely, consult your Newmans representative for recommendations.





Swing Check Valves

Sizes: 2" thru 24" **Class:** 150 thru 1500

Swing Check valves yield minimal restriction to low velocity environments and are ideal for preventing pipeline back flow in unidirectional flow applications in horizontal or upward (vertical) flow piping.

Tilting Disc Check Valves

Sizes: 2" thru 24" **Class:** 150 thru 1500

Tilting Disc Check valves yield minimal restriction to low velocity environments and are ideal for preventing pipeline back flow in unidirectional flow applications in horizontal or upward (vertical) flow piping. The Tilting Disc design helps to minimize the slamming of the disc when back-flow occurs.



Stop Check Valves

Sizes: 2" thru 18" **Class:** 150 thru 1500

Stop Check valves are designed much the same as Globe Valves, except there is no mechanical connection (Split Lock Ring) between the stem and disc. They are designed to give check valve protection in the event of fluid back flow, and are commonly used to prevent flow from a header fed by multiple sources when there is a loss in pressure in one of the sources. Stop checks must be installed with line pressure under the disc so only boiler pressure can raise the disc. Stop Checks must be installed horizontally.

Angle Stop Check Valves

Sizes: 2" thru 12" **Class:** 150 thru 600

Angle Stop Check valves are designed much the same as Angle Globe Valves, except there is no mechanical connection (Split Lock Ring) between the stem and disc. They are designed to give check valve protection in the event of fluid back flow, and are commonly used to prevent flow from a header fed by multiple sources when there is a loss in pressure in one of the sources. Stop checks must be installed with line pressure under the disc so only boiler pressure can raise the disc.



Newmans' Product Range

Brand	Type	Size	Class	Ends	Available Material**
Newco	Cast Carbon	* 2" to 48"	150 - 2500	RF, RTJ, BW	WCB, LCC
Newco	Cast Alloy	2" to 24"	150 - 2500	RF, RTJ, BW	C5, C6, C9, C12, C12A
Newco	Cast Iron	2" to 36"	125	FF	A126 - Cl. B
Newco	Ductile Iron	2" to 36"	150	RF	A395
Newco	Forged Carbon	1/4" to 2"	150 - 4500	FLGD, THRD, SW	A105N, LF2
Newco	Forged Alloy	1/4" to 2"	150 - 4500	FLGD, THRD, SW	F5, F9, F11, F22, F91, F51
Newco	Pressure Seal	2" to 24"	600 - 4500	RF, RTJ, BW	Cast - all grades
Newco	Floating Ball	1/2" to 18"	150 - 600	RF	WCB, LCC, CF8M
Newco	Trunnion Ball & QuadroSphere	2" to 36"	150 - 2500	RF, BW	A105, LF2, F316, F51
OIC	Cast Stainless	1/2" to 24"	150 - 2500	RF, RTJ, BW	304/L, 316/L, 317/L, 321, 347/H, A20
OIC	Forged Stainless	1/4" to 2"	150 - 4500	FLGD, THRD, SW	304/L, 316/L, 317/L, 321, 347, A20
Cooper	Cast Alloy	1/4" to 24"	150 - 1500	FLGD, THRD, SW, BW	Monel, Inconel, Hastelloy, Titanium, Zirconium, Duplex
Cooper	Forged Alloy	1/4" to 3"	800 - 1500	FLGD, THRD, SW, BW	Monel, Inconel, Hastelloy, Titanium, Zirconium, Duplex
Cooper	Ball Valves	1/4" to 3"	1500 PSI	THRD, SW, BW	Monel, Inconel, Hastelloy, Titanium, Zirconium, Duplex
Cooper	Ball Valves	1/2" to 12"	150 - 900 PSI	FLGD	Monel, Inconel, Hastelloy, Titanium, Zirconium, Duplex

* Larger sizes available upon request. ** other materials available upon request.

Valve & I.D. Tag Overview

The identification tag displays all construction and tracking data regarding the respective valve on which it is attached. Below is a general overview of the identification tag components.

I.D. Tags are located in 1 of the 3 following areas:

- yoke
- body/bonnet flange
- under the handwheel nut

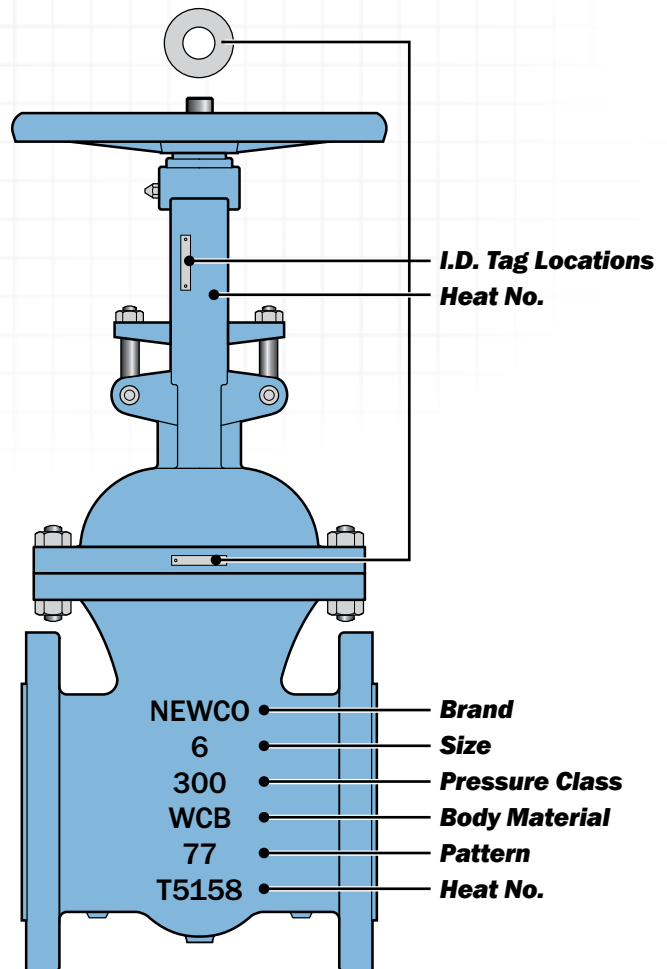
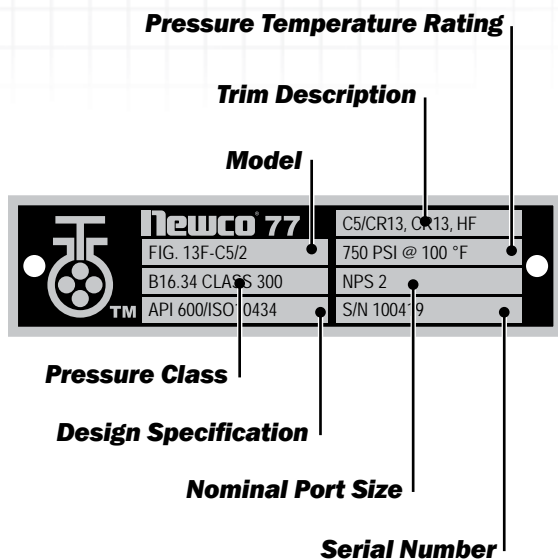

How to Order Newco Products

Note: OIC and Cooper “How to Order” information can be found in their respective catalogs.

Figure Number

The figure number shown below identifies specific valve configuration details of Newco valves such as valve type, pressure class, end connections, body/bonnet & trim materials, and special features.

Please specify end connections, body materials, and trims not listed below.

When placing an order, please refer to the respective product section of the catalog for size availability. A detailed description must be included with any special orders.

Type	
1	= Gate, OS&Y
2	= Globe/Globe Stop Check, OS&Y
3	= Swing/Tilting Disc Check
4	= Piston Check
5	= Ball
6	= Gate, NRS
7	= Angle/Angle Stop Check, OS&Y

Pressure Class	
1	= 150
2	= 125
3	= 300
6	= 600
8	= 800
9	= 900
15	= 1500
16	= 1690
25	= 2500
26	= 2680
45	= 4500

End Connections	
F	= Flanged
J	= RTJ
S	= Socket Weld
T	= Threaded
W	= Butt Weld
X	= Threaded x Socket Weld

Trim Material	API Trim =
1 = CR13	1, 4, 8A
2 = CR13/HF**	8
3 = CR13/FHF**	5
4 = 316	10
4/2 = 316/HF**	12
4/3 = 316/FHF**	16
5 = NI Cu (Monel***)	9
5/2 = Monel/HF**	11
6 = Alloy 20	13
7 = Bronze	N/A
A7 = Aluminum Bronze	N/A
8 = Iron	N/A
9 = Special (Customer to Specify)	

Fig. 11F-CB2__

Body/Bonnet Material		
A20	= ASTM A351, CN7M	= Cast Alloy 20
CB	= ASTM A216, WCB	= Cast Carbon Steel
CC	= ASTM A216, WCC	= Cast Carbon Steel
C5	= ASTM A217, C5	= Cast Alloy Steel (5% Chrome, .5% Moly)
C6	= ASTM A217, WC6	= Cast Alloy Steel (1.25% Chrome, .5% Moly)
C9	= ASTM A217, WC9	= Cast Alloy Steel (2.25% Chrome, 1% Moly)
C12	= ASTM A217, C12	= Cast Alloy Steel (9% Chrome, 1% Moly)
12A	= ASTM A217, C12A	= Cast Alloy Steel (9% Chrome, 1% Moly, V)
CF3	= ASTM A351, CF3	= Cast Stainless Steel
C3M	= ASTM A351, CF3M	= Cast 316L Stainless Steel
CF8	= ASTM A351, CF8	= Cast 304 Stainless Steel
C7L	= ASTM A351, CG3M	= Cast 317L Stainless Steel
C8M	= ASTM A351, CF8M	= Cast 316 Stainless Steel
C8C	= ASTM A351, CF8C	= Cast 347 Stainless Steel
CT	= ASTM A351, CG8M	= Cast 317 Stainless Steel
DI	= ASTM A395	= Cast Ductile Iron
FS	= ASTM A105	= Forged Carbon Steel
F3	= ASTM A182, F316L	= Forged 316 Stainless Steel
F5	= ASTM A182, F5	= Forged Alloy Steel (5% Chrome, .5% Moly)
F7	= ASTM A182, 317	= Forged 317 Stainless Steel
F7L	= ASTM A182, F317L	= Forged 317L Stainless Steel
F11	= ASTM A182, F11	= Forged Alloy Steel (1.25% Chrome, .5% Moly)
F22	= ASTM A182, F22	= Forged Alloy Steel (2.25% Chrome, 1% Moly)
F9	= ASTM A182, F9	= Forged Alloy Steel (9% Chrome, 1% Moly)
F91	= ASTM A182, F91	= Forged Alloy Steel (9% Chrome, 1% Moly, V)
F8	= ASTM A182, F304	= Forged 304 Stainless Steel
F8M	= ASTM A182, F316	= Forged 316 Stainless Steel
F8C	= ASTM A182, F321	= Forged 321 Stainless Steel
IB	= ASTM A126, CLB	= Cast Iron
LCC	= ASTM A352, LCC	= Cast Low Temperature Carbon Steel
LF-2	= ASTM A350, LF2	= Forged Low Temperature Carbon Steel
MO	= ASTM A414, M35	= Cast NI Cu (Monel***)
SPL	= Special (Customer to specify)	

Suffix Letters	
BP	= By Pass
BS	= Bellows Seal
CL	= Chlorine Service
CR	= Cryogenic Service
CW	= Chain Wheel
EB	= Extended Bonnet
FP	= Full Port
FS	= Fire Safe
GI	= Grease Injection
GO	= Gear Operated
HB	= Horizontal Ball Check
HP	= Horizontal Piston Check
HO	= Hydraulic Operator
LD	= Locking Device
LL	= Locking Loop
LV	= Live Load Packing
MO	= Motor Operated
NC	= Material to NACE MR-01-75
OL	= Outside Weight & Lever
OX	= Oxygen Service
PO	= Pneumatic Operator
PS	= Pressure Seal Bonnet
PT	= PTFE Seats
QS	= QuadroSphere
RP	= Regular Port
SC	= Stop Check
SL	= Spring Loading
SPL	= Special (Customer to specify)
TD	= Tilting Disc Check
TF	= Teflon* Insert
TM	= Trunnion Mounted
VP	= Vertical Ball Check
VL	= Vertical Lift Check
VP	= V-Port Disc
VT	= Viton* Insert
WB	= Welded Bonnet
*	= Viton and Teflon are registered trademarks of DuPont Company
**HF	= Hardfaced - AWS 5.13 Class C ₀ C _r A
***	= Monel is a registered trademark of International Nickel Company

Body/Bonnet Materials

Newco cast steel valves are available in stock in a wide range of body/bonnet materials and optional trim materials. Listed below are some of the more popular materials. Additional materials are available. Please contact Newmans or your local distributor for details.

Newco Material Designation	Common Description	ASTM Specs.	Body/Bonnet Material Service Limitations *
CB	Carbon Steel	A216	Non-corrosive service water, oil, & gases at temperatures between -20° F & +800° F
LCC	Low Temp Carbon	A352	Low temperature service between -50° F & +650° F
WC6	1.25% Chrome & .5% Moly	A217	Non-corrosive service water, oil, & gases at temperatures between -20° F & +1100° F
WC9	2.25% Chrome & 1% Moly	A217	Non-corrosive service water, oil, & gases at temperatures between -20° F & +1100° F
C5	5% Chrome & .5% Moly	A217	Corrosive, non-corrosive, or erosive service at temperatures between -20° F & +1200° F
C12	9% Chrome & 1% Moly	A217	Corrosive, non-corrosive, or erosive service at temperatures between -20° F & +1200° F
C12A	9% Chrome, 1% Moly, & V	A217	Corrosive, non-corrosive, or erosive service at temperatures between -20° F & +1200° F
C8M	Cast 316	A351	Corrosive, cryogenic or high temperature service between -450° F & +1200° F
A20	Alloy 20	A351	Corrosive service at temperatures between -20° F & +300° F

* Limitations are per 2004 Edition of ASME B16.34.

Trim Materials

The following are Newco's standard trim designations.

Newco Trim Number	Common Name	API 600 Trim No.	Seat Ring Facing (1)	Wedge or Disc Facing (1)	Stem	Other Trim Parts (2)	Service Limitations
1	13 Chrome	1	CR 13	CR 13	CR 13	CR 13	Non-corrosive applications. Steam, gas, & general service to 700° F. Oil & oil vapor to 900° F
2	Half Stellite	8	HF	CR 13	CR 13	CR 13	Steam, gas, & general service to 1000° F. Standard trim for gate valves
3	Full Stellite	5	HF	HF	CR 13	CR 13	Premium trim service to 1200° F. Excellent for high pressure water and steam service
4	316	10	316	316	316	316	Corrosive services to 850° F. Low temperature service standard for 316 SS valves
4/2	316/Half Stellite	12	HF	316	316	316	
4/3	316/Full Stellite	16	HF	HF	316	316	
5	Monel	9	NiCu	NiCu	NiCu	NiCu	Corrosive services to 750° F
5/2	Monel/Half Stellite	11	HF	NiCu	NiCu	NiCu	
5/3	Monel/Full Stellite	-	HF	HF	NiCu	NiCu	
6	Alloy 20	13	A20	A20	A20	A20	Corrosive services to 300° F
7	Bronze	-	BRZ	BRZ	BRZ	BRZ	Water, gas, or low pressure steam to 450° F
A7	Aluminum Bronze	-	AL BRZ	AL BRZ	AL BRZ	AL BRZ	
8	Iron	-	Iron	Iron	STL	Iron or STL	
X	Special	Special	Special	Special	Special	Special	Customer to specify

(1) Facing is defined as the seating surface of a seat ring and wedge/disc

(2) Other trim parts are defined as small internal parts that are normally in contact with the service fluid. This includes the stem, backseat bushing in gate and globe valves and the swing check disc nut

Newco Features and Benefits

- Certifications
- International Organization for Standardization (ISO)
- Traceability
- Fugitive Emissions Tested
- API-598 Tested
- Major End-user Approved
- Multiple North American Locations
- Extensive Engineering Capabilities
- Excellent Customer Service
- Warranty
- Onsite Non-destructive Testing
- Field Services for Start-up
- Inhouse Automation Capabilities

Pressure Temperature Ratings - ASME B16.34 - 2004

Class 150							
Temperature °F	WCB*	LCC	WC6	WC9	C5	C12	C12A
-20 to 100	285	290	290	290	290	290	290
200	260	260	260	260	260	260	260
300	230	230	230	230	230	230	230
400	200	200	200	200	200	200	200
500	170	170	170	170	170	170	170
600	140	140	140	140	140	140	140
650	125	125	125	125	125	125	125
700	110	110	110	110	110	110	110
750	95	95	95	95	95	95	95
800	80	80	80	80	80	80	80
850	65	65	65	65	65	65	65
900	50	50	50	50	50	50	50
950	35	35	35	35	35	35	35
1000	20	20	20	20	20	20	20
1050	-	-	20**	20**	20**	20**	20
1100	-	-	20**	20**	20**	20**	20
1150	-	-	-	-	20**	20**	20
1200	-	-	-	-	20**	20**	20

Class 300							
Temperature °F	WCB*	LCC	WC6	WC9	C5	C12	C12A
-20 to 100	740	750	750	750	750	750	750
200	680	750	750	750	750	750	750
300	655	730	720	730	730	730	730
400	635	705	695	705	705	705	705
500	605	665	665	665	665	665	665
600	570	605	605	605	605	605	605
650	550	590	590	590	590	590	590
700	530	555	570	570	570	570	570
750	505	505	530	530	530	530	530
800	410	410	510	500	510	510	510
850	320	320	485	485	485	485	485
900	230	225	450	450	375	450	450
950	135	135	320	385	275	375	385
1000	85	85	215	265	200	255	365
1050	-	-	145	175	145	170	360
1100	-	-	95	110	100	115	300
1150	-	-	65	70	60	75	225
1200	-	-	40	40	35	50	145

Class 600							
Temperature °F	WCB*	LCC	WC6	WC9	C5	C12	C12A
-20 to 100	1480	1500	1500	1500	1500	1500	1500
200	1360	1500	1500	1500	1500	1500	1500
300	1310	1455	1445	1455	1455	1455	1455
400	1265	1405	1385	1410	1410	1410	1410
500	1205	1330	1330	1330	1330	1330	1330
600	1135	1210	1210	1210	1210	1210	1210
650	1100	1175	1175	1175	1175	1175	1175
700	1060	1110	1135	1135	1135	1135	1135
750	1015	1015	1065	1065	1065	1065	1065
800	825	825	1015	1015	1015	1015	1015
850	640	640	975	975	975	975	975
900	460	445	900	900	745	900	900
950	275	275	640	755	550	755	775
1000	170	170	430	535	400	505	725
1050	-	-	290	350	290	345	720
1100	-	-	190	220	200	225	605
1150	-	-	130	135	125	150	445
1200	-	-	80	80	70	105	290

Class 900							
Temperature °F	WCB*	LCC	WC6	WC9	C5	C12	C12A
-20 to 100	2220	2250	2250	2250	2250	2250	2250
200	2035	2250	2250	2250	2250	2250	2250
300	1965	2185	2165	2185	2185	2185	2185
400	1900	2110	2080	2115	2115	2115	2115
500	1810	1995	1995	1995	1995	1995	1995
600	1705	1815	1815	1815	1815	1815	1815
650	1650	1765	1765	1765	1765	1765	1765
700	1590	1665	1705	1705	1705	1705	1705
750	1520	1520	1595	1595	1595	1595	1595
800	1235	1235	1525	1525	1525	1525	1525
850	955	955	1460	1460	1460	1460	1460
900	690	670	1350	1350	1120	1350	1350
950	410	410	955	1160	825	1130	1160
1000	255	255	650	805	595	760	1090
1050	-	-	430	525	430	515	1080
1100	-	-	290	330	300	340	905
1150	-	-	195	205	185	225	670
1200	-	-	125	125	105	155	430

Class 1500							
Temperature °F	WCB*	LCC	WC6	WC9	C5	C12	C12A
-20 to 100	3705	3750	3750	3750	3750	3750	3750
200	3395	3750	3750	3750	3750	3750	3750
300	3270	3640	3610	3640	3640	3640	3640
400	3170	3520	3465	3530	3530	3530	3530
500	3015	3325	3325	3325	3325	3325	3325
600	2840	3025	3025	3025	3025	3025	3025
650	2745	2940	2940	2940	2940	2940	2940
700	2665	2775	2840	2840	2840	2840	2840
750	2535	2535	2660	2660	2660	2660	2660
800	2055	2055	2540	2540	2540	2540	2540
850	1595	1595	2435	2435	2435	2435	2435
900	1150	1115	2245	2245	1870	2245	2245
950	685	685	1595	1930	1370	1885	1930
1000	430	430	1080	1335	995	1270	1820
1050	-	-	720	875	720	855	1800
1100	-	-	480	550	495	565	1510
1150	-	-	325	345	310	375	1115
1200	-	-	205	205	170	255	720

Class 2500							
Temperature °F	WCB*	LCC	WC6	WC9	C5	C12	C12A
-20 to 100	6170	6250	6250	6250	6250	6250	6250
200	5655	6250	6250	6250	6250	6250	6250
300	5450	6070	6015	6070	6070	6070	6070
400	5280	5865	5775	5880	5880	5880	5880
500	5025	5540	5540	5540	5540	5540	5540
600	4730	5040	5040	5040	5040	5040	5040
650	4575	4905	4905	4905	4905	4905	4905
700	4425	4630	4730	4730	4730	4730	4730
750	4230	4230	4430	4430	4430	4430	4430
800	3430	3430	4230	4230	4230	4230	4230
850	2655	2655	4060	4060	4060	4060	4060
900	1915	1855	3745	3745	3115	3745	3745
950	1145	1145	2655	3220	2285	3145	3220
1000	715	715	1800	2230	1655	2115	3030
1050	-	-	1200	1455	1200	1430	3000
1100	-	-	800	915	830	945	2515
1150	-	-	545	570	515	630	1855
1200	-	-	345	345	285	430	1200

* Not recommended for prolonged use above 800° F. ** For weld end valves only. Flanged end ratings terminate at 1000° F. Note: Packing, gasket, or bolting may limit temperature. Please advise service temperature if above 1000° F. Ratings from ASME B16.34 standard class valves. Special class weld end valves to ASME B16.34 are available on special order.

Flange Dimensions - ASME B16.5

Class 150 & 300

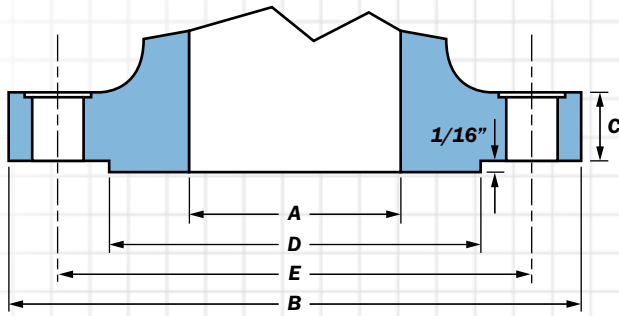

Class 600 thru 2500

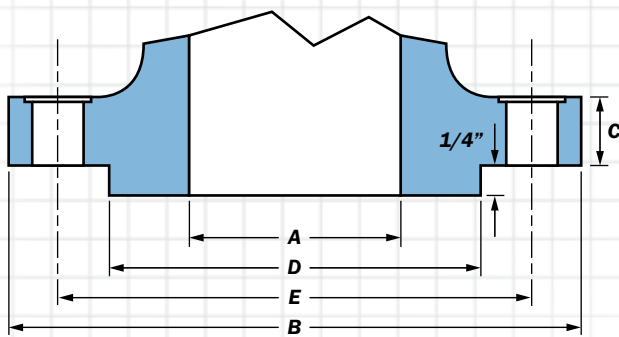

Standards: NPS 24 and smaller in all classes conform to ASME B16.5. NPS 30 and larger conform to ASME B16.47 (Series A).

Facing: End flanges are regularly furnished with a raised face having a serrated finish per MSS SP-6. The thickness of the flange dimension (C) includes the raised face for Class 150 and 300. For Class 600 thru 2500, the flange dimension (C) does not include the 1/4" raised face.

Bolt Holes: Bolt holes are 1/8" larger than the bolt diameter. Bolt holes are drilled to straddle the center line.

Flange Dimensions in Inches								
Class	Size	A	B	C	D	E	Stud Bolts	
							No.	Dia.
150	2	2.00	6.00	0.75	3.62	4.75	8	0.63
	2.5	2.50	7.00	0.88	4.12	5.50	8	0.63
	3	3.00	7.50	0.94	5.00	6.00	8	0.63
	4	4.00	9.00	0.94	6.19	7.50	8	0.63
	5	5.00	10.00	0.94	7.31	8.50	8	0.75
	6	6.00	11.00	1.00	8.50	9.50	12	0.75
	8	8.00	13.50	1.12	10.62	11.75	12	0.75
	10	10.00	16.00	1.19	12.75	14.25	16	0.88
	12	12.00	19.00	1.25	15.00	17.00	16	0.88
	14	13.25	21.00	1.38	16.25	18.75	20	1.00
	16	15.25	23.50	1.44	18.50	21.25	20	1.00
	18	17.25	25.00	1.56	21.00	22.75	24	1.13
	20	19.25	27.50	1.69	23.00	25.00	24	1.13
	24	23.25	32.00	1.88	27.25	29.50	24	1.25
	30	29.25	38.75	2.94	33.75	36.00	28	1.25
	36	35.06	46.00	3.56	40.25	42.75	32	1.50
42	40.87	53.00	3.81	47.00	49.50	36	1.50	
48	46.00	59.50	4.25	53.50	56.00	44	1.50	

Flange Dimensions in Inches									
Class	Size	A	B	C	D	E	Stud Bolts		
							No.	Dia.	
300	2	2.00	6.50	0.88	3.62	5.00	8	0.63	
	2.5	2.50	7.50	1.00	4.12	5.88	8	0.75	
	3	3.00	8.25	1.12	5.00	6.62	8	0.75	
	4	4.00	10.00	1.25	6.19	7.88	8	0.75	
	5	5.00	11.00	1.38	7.31	9.25	8	0.75	
	6	6.00	12.50	1.44	8.50	10.62	12	0.75	
	8	8.00	15.00	1.62	10.62	13.00	12	0.88	
	10	10.00	17.50	1.88	12.75	15.25	16	1.00	
	12	12.00	20.50	2.00	15.00	17.75	16	1.13	
	14	13.25	23.00	2.12	16.25	20.25	20	1.13	
	16	15.25	25.50	2.25	18.50	22.50	20	1.25	
	18	17.00	28.00	2.38	21.00	24.75	24	1.25	
	20	19.00	30.50	2.50	23.00	27.00	24	1.25	
	24	23.00	36.00	2.75	27.25	32.00	24	1.5	
	30	29.00	43.00	3.62	33.75	39.25	28	1.75	
	36	34.50	50.00	4.12	40.25	46.00	32	2.00	
600	2	2.00	6.50	1.00	3.62	5.00	8	0.63	
	2.5	2.50	7.50	1.12	4.12	5.88	8	0.75	
	3	3.00	8.25	1.25	5.00	6.62	8	0.75	
	4	4.00	10.75	1.50	6.19	8.50	8	0.88	
	5	5.00	13.00	1.75	7.31	10.50	8	1.00	
	6	6.00	14.00	1.88	8.50	11.50	12	1.00	
	8	7.88	16.50	2.19	10.62	13.75	12	1.13	
	10	9.75	20.00	2.50	12.75	17.00	16	1.25	
	12	11.75	22.00	2.62	15.00	19.25	20	1.25	
	14	12.88	23.75	2.75	16.25	20.75	20	1.38	
	16	14.75	27.00	3.00	18.50	23.75	20	1.5	
	18	16.50	29.25	3.25	21.00	25.75	20	1.63	
	20	18.25	32.00	3.50	23.00	28.50	24	1.63	
	24	22.00	37.00	4.00	27.25	33.00	24	1.88	
	30	27.37	44.50	4.50	33.75	40.25	28	2.00	
	36	32.87	51.75	4.88	40.25	47.00	28	2.50	
900	3	2.88	9.50	1.50	5.00	7.50	8	0.88	
	4	3.88	11.50	1.75	6.19	9.25	8	1.13	
	5	4.75	13.75	2.00	7.31	11.00	8	1.25	
	6	5.75	15.00	2.19	8.50	12.50	12	1.13	
	8	7.50	18.50	2.50	10.62	15.50	12	1.38	
	10	9.38	21.50	2.75	12.75	18.50	16	1.38	
	12	11.12	24.00	3.12	15.00	21.00	20	1.38	
	14	12.25	25.25	3.38	16.25	22.00	20	1.50	
	16	14.00	27.75	3.50	18.50	24.25	20	1.63	
	18	15.75	31.00	4.00	21.00	27.00	20	1.88	
	20	17.50	33.75	4.25	23.00	29.50	20	2.00	
	24	21.00	41.00	5.50	27.25	35.50	20	2.50	
	1500	2	1.88	8.50	1.50	3.62	6.50	8	0.88
		2.5	2.25	9.62	1.62	4.12	7.50	8	1.00
		3	2.75	10.50	1.88	5.00	8.00	8	1.13
		4	3.62	12.25	2.12	6.19	9.50	8	1.25
5		4.38	14.75	2.88	7.31	11.50	8	1.50	
6		5.38	15.50	3.25	8.50	12.50	12	1.38	
8		7.00	19.00	3.62	10.62	15.50	12	1.63	
10		8.75	23.00	4.25	12.75	19.00	12	1.88	
12		10.38	26.50	4.88	15.00	22.50	16	2.00	
14		11.38	29.50	5.25	16.25	25.00	16	2.25	
16		13.00	32.50	5.75	18.50	27.75	16	2.50	
18		14.62	36.00	6.38	21.00	30.50	16	2.75	
20		16.38	38.75	7.00	23.00	32.75	16	3.00	
24		19.62	46.00	8.00	27.25	39.00	16	3.50	
2500		2	1.50	9.25	2.00	3.62	6.75	8	1.00
		2.5	1.88	10.50	2.25	4.12	7.75	8	1.13
	3	2.25	12.00	2.62	5.00	9.00	8	1.25	
	4	2.88	14.00	3.00	6.19	10.75	8	1.50	
	5	3.62	16.50	3.62	7.31	12.75	8	1.75	
	6	4.38	19.00	4.25	8.50	14.50	8	2.00	
	8	5.75	21.75	5.00	10.62	17.25	12	2.00	
	10	7.25	26.50	6.50	12.75	21.75	12	2.50	
	12	8.62	30.00	7.25	15.00	24.38	12	2.75	

Auxiliary Connection Locations (Bypasses, Drains, etc.)

Please refer to ASME B16.34 for exact auxiliary connection locations, sizes, and threading information.

Each letter in the illustration(s) below identify the possible hole locations for auxiliary connection(s). These illustrations are for reference purposes only.

Unless specified otherwise, auxiliary connection hole sizes shall be drilled and tapped as follows:

- 2" thru 4" utilizes a .50" hole
- 5" thru 8" utilizes a .75" hole
- 10" and larger utilizes a 1" hole

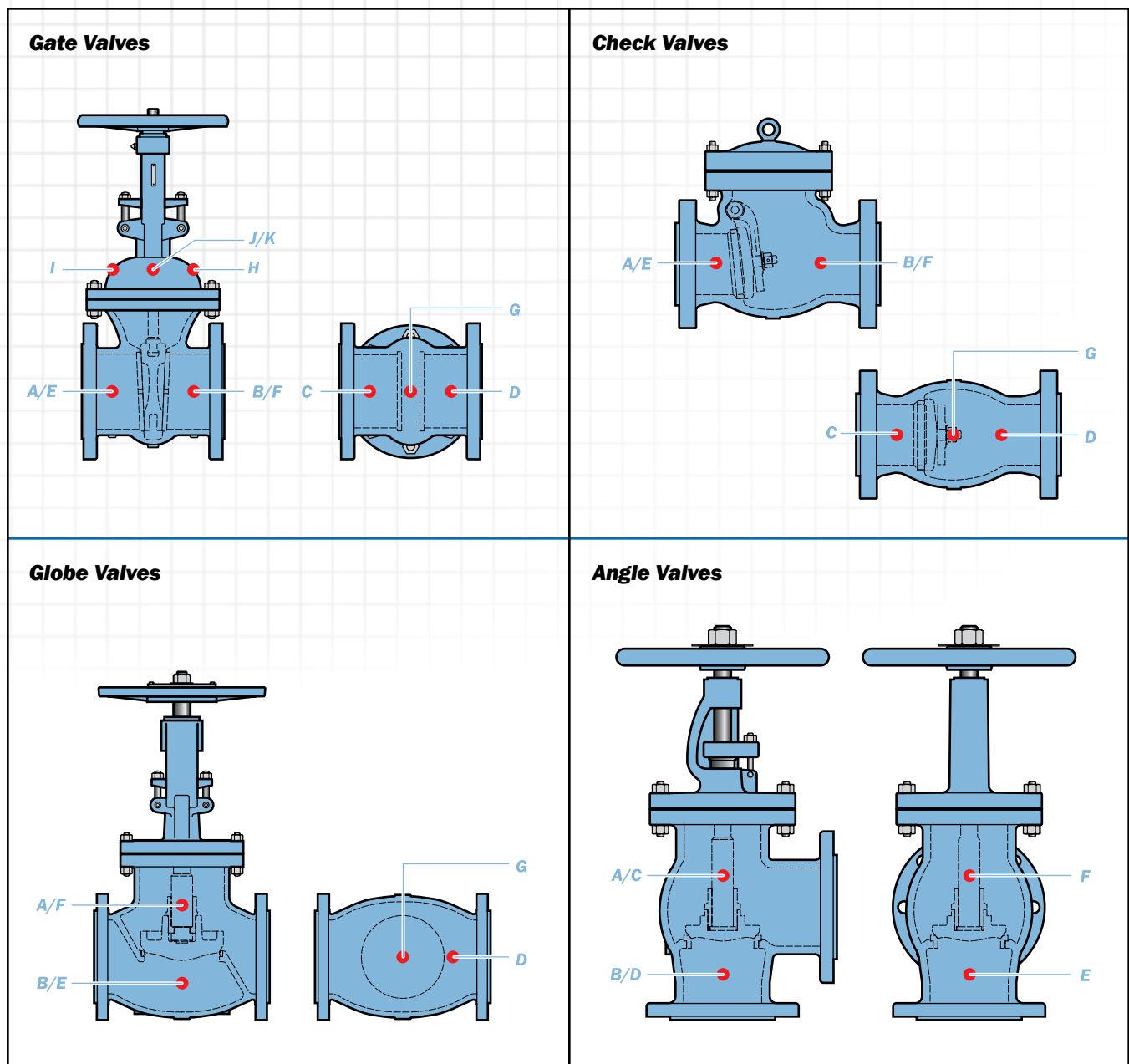

Products & Services

VALVES

NEWCO

- Full Line of Gate, Globe, and Check Valves in Forged Steel, and Cast Steel
- Trunnion Mounted Ball Valves
- Floating Ball Valves
- QuadroSphere® Trunnion Mounted Ball Valves

OIC

- Gate, Globe, and Check Valves in Stainless Steel

COOPER

- Gate, Globe, and Check Valves Flanged, Threaded, and Socket Weld in Cast and Forged Exotic Alloy, and Stainless Steel
- Flanged and 3-Piece Ball Valves in Exotic Alloy

Manual Operations

- Worm Gears, Spur Gears, Bevel Gears, and Reach Rods
- Table Stands, Extension Systems, and Brackets
- Field and Shop Installation Services

Valve Modification

- By Passes, Bore Changes, Mounting Plates, Stem Extensions, Limit Switches, Trim Changes, etc. (Inquire within)

AUTOMATION

Valve & Damper Actuation

- Electric, Hydraulic, and Pneumatic Actuation
- Multi-turn, Quarter-turn, and Linear
- New Applications and Field Retrofits
- Capabilities and Support for all Actuators including: **Limitorque, Rotork, Auma, EIM, Bettis, Automax, Fisher, Miller, and Hanna**

Automation Site Services

- Experienced Field Technicians
- Actuator Installation, Setting, Calibration, Start-up
- Commissioning and Repair Services
- Automation and Control Surveys

Automation Shop Services

- Experienced Shop Technicians
- Complete Automated Valve Assemblies
- Special Wiring Diagrams and Control Schematic
- Shop Acuator Repairs on **Limitorque, Rotork, Auma, and EIM**

Controls & Digital Communications

- Pneumatic and Hydraulic Services
- Solenoid and Speed Control Valves; Limit Switches
- Two-wire Integration, Field Bus, ModBus, ProfiBus, DeviceNet, EtherNet, Serial Communications, Network Control Systems

Specialists in Electric and Pneumatic Actuation

Newco®

Cast Steel Bolted Bonnet Gate Valves

Manufactured by Newmans™

Sizes: 2" thru 48" • Pressure Class: 150 thru 1500



Typical Newco Cast Steel Bolted Bonnet Gate Valve Expanded View

1. Body: Newco cast steel bodies provide low resistance flow and optimum strength and performance.

2. Yoke & Bonnet: Newco bonnet assemblies are built to the same standards as the bodies. Larger size gate valves utilize a multi-piece bonnet design.

3. Grease Fitting: The grease fitting allows for easy stem lubrication.

4. Stem: The stem is precision machined and inserts into the horizontal channel in the disc.

5. Wedge: Newmans 1-piece flex wedge is machined to the tightest tolerances to ensure trouble free shutoff and cycling.

6. Back Seat Bushing: The back seat, when engaged with the stem head, provides a stable shutoff to the stuffing box which isolates the packing from flow exposure.

7. Gland: Compresses the packing to create a stem seal above the back seat, between the bonnet and stem.

8. Gland Flange: Applies pressure to the gland for accurate packing adjustments.

9. & 10. Gland Bolts & Nuts: The gland bolt and nut allows for easy adjustments for packing compression.

11. Gland Bolt Pin: The gland bolt pin secures the gland bolts to the yoke & bonnet.

12. Packing: The packing creates a seal above the back seat, between the bonnet and stem.

13. Stuffing Box: The stuffing box contains the packing.

14. Stem Nut: The stem nut provides a precision guide for proper stem alignment.

15. Yoke Bushing: The retaining nut secures the stem nut to the bonnet assembly.

16. Handwheel: The handwheel cycles the valve.

17. Handwheel Nut: The handwheel nut secures the handwheel to the bonnet assembly.

18. Set Screw: The set screw prevents handwheel nut loosening.

19. Bonnet Gasket: The bonnet gasket creates a leakproof seal between the bonnet and body.

20. & 21. Bonnet Studs & Nuts: The bonnet studs and nuts secure the bonnet to the body.

22. Seat Rings: To ensure a stable shutoff, seat rings are aligned and seal-welded into the valve, then precision ground for optimal seating.

23. Spacer Ring: Assists the packing rings in creating a seal above the back seat, between the bonnet and stem.

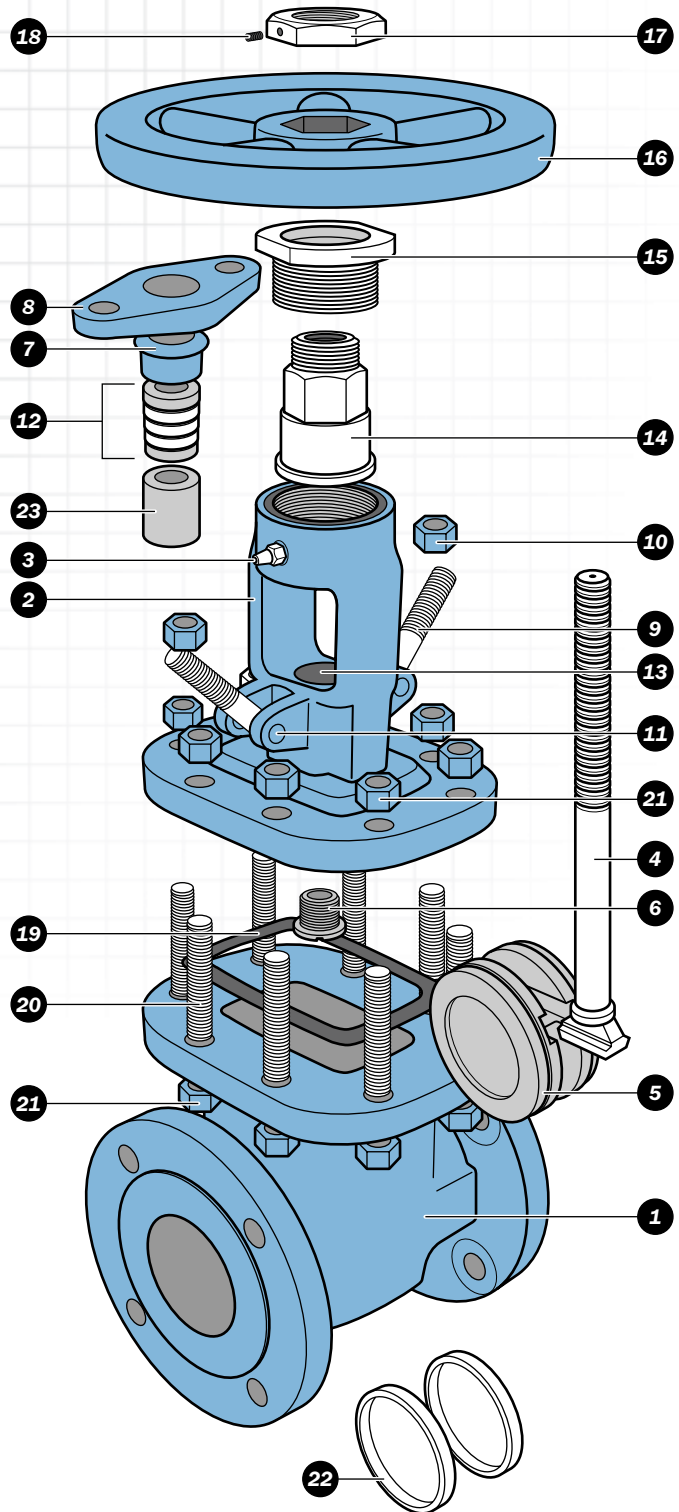

Cast Steel Bolted Bonnet Gates

Styles: CB2, CB3, & CB4/2

Class 150 - Sizes: 2" thru 48"

Pressure Class Range: 150 thru 1500

Design and Manufacturing Standards

Valve Design: ASME B16.34/API 600

Flange Dimensions: ASME B16.5, B16.47 (Series A)

Face-to-Face Dimensions: ASME B16.10

Tested in Accordance with: API 598

Recommended Spare Parts*

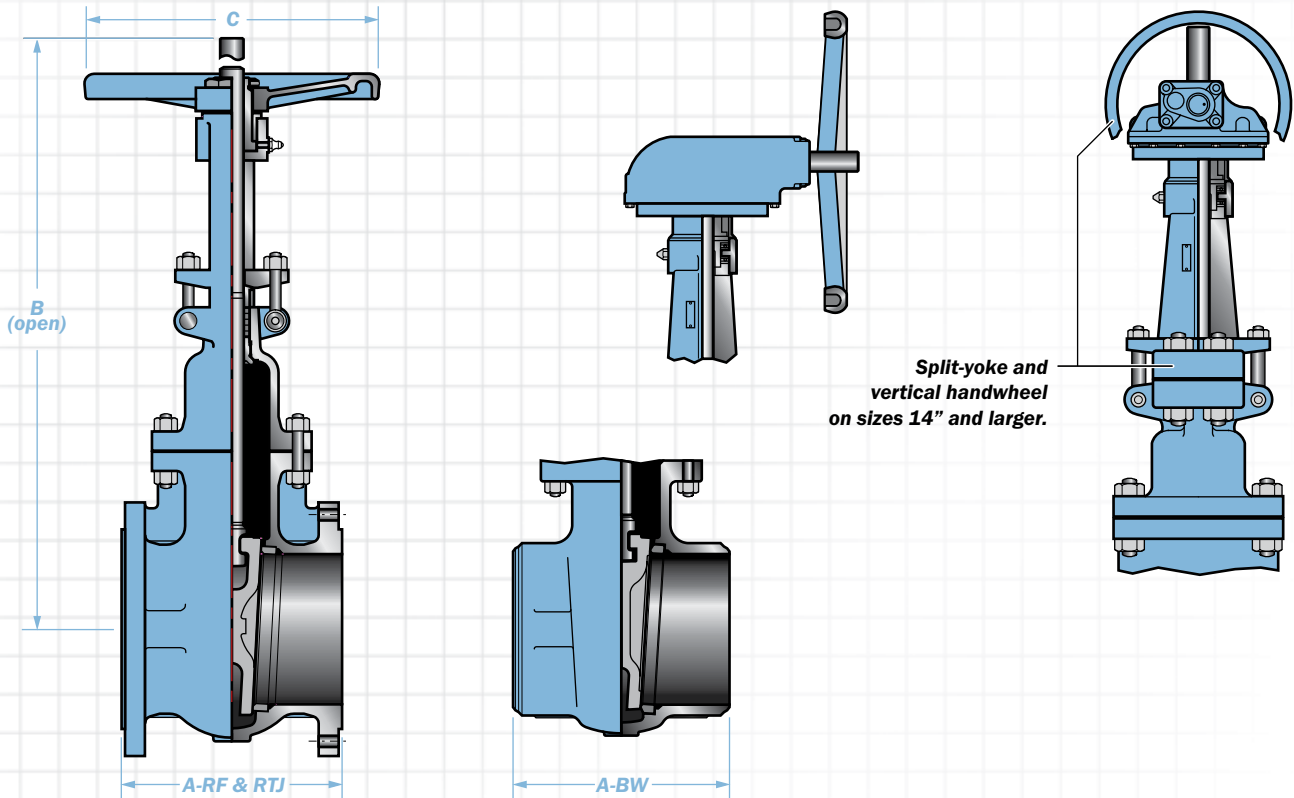

Typical Bill of Materials (See page 5 for available materials.)

Component	CB2	CB3	CB4/2	Component	CB2	CB3	CB4/2
Body	ASTM A216-WCB			Gland Flange	ASTM A216-WCB		
Seat Rings	ASTM A105/HF			Gland Bolt Pins	ASTM A36		
Wedge 2" - 3"	ASTM A276-410	ASTM A216-WCB/HF	ASTM A351-CF8M/A276-316	Gland Bolts	ASTM A307-B		
Wedge 4" & larger	ASTM A216-WCB w/13% Chrome		ASTM A276-316	Gland Nuts	ASTM A194-2H		
Stem	ASTM A182-F6a		ASTM A182-316	Nameplate	Stainless Steel 304		
Yoke & Bonnet	ASTM A216-WCB			Nameplate Rivets	Stainless Steel - Commercial		
*Bonnet Gasket	Multilayered Corrugated 316 w/Graphite			Grease Fitting	Carbon Steel - Commercial		
Bonnet Nuts	ASTM A194-2H	ASTM A194-2HM		Stem Nut	ASTM A439-D2		
Bonnet Studs	ASTM A193-B7	ASTM A193-B7M		Yoke Bushing	ASTM A536 (65-45-12)		
Back Seat Bushing	ASTM A276-410	ASTM A276-316		Handwheel	ASTM A536 (65-45-12)		
*Packing	Graphite w/Braided Carbon Fiber End Rings			Handwheel Nut	ASTM A536 (65-45-12)		
Gland	ASTM A276-410	ASTM A276-316		Set Screw	ASTM A193-B6		
				Spacer Ring	N/A		

Class 150

Size	nps	2	2.5	3	4	5	6	8	10	12	14	16	18	20	24	30	36	42	48
	dn	50	65	80	100	125	150	200	250	300	350	400	450	500	600	750	900	1050	1200
A-RF	in	7.0	7.5	8.0	9.0	10.0	10.5	11.5	13.0	14.0	15.0	16.0	17.0	18.0	20.0	24.0	28.0	31.0	34.0
	mm	178	191	203	229	254	267	292	330	356	381	406	432	457	508	610	711	813	864
A-BW	in	8.5	9.5	11.1	12.0	15.0	15.9	16.5	18.0	19.8	22.5	24.0	26.0	28.0	32.0	24.0	28.0	43.0	46.0
	mm	216	241	282	305	381	404	419	457	503	572	610	660	711	813	610	711	1092	1168
B	in	14.8	17.1	18.2	22.6	28.1	33.2	38.9	46.4	54.6	63.5	72.4	79.2	86.0	100.8	125.1	153.2	174.4	217.5
	mm	376	434	462	574	714	843	988	1179	1387	1613	1839	2012	2184	2560	3178	3891	4430	5525
C	in	8.0	8.0	8.0	10.0	13.0	14.0	16.0	18.0	20.0	18.1	18.1	18.1	18.1	21.3	24.0	31.8	31.5	35.4
	mm	203	203	203	254	330	357	406	457	508	460	460	460	460	541	610	808	800	900
RF Wt.	lbs	46	56	71	111	163	196	289	449	639	860	1190	1389	1786	2602	4466	4850	10134	15677
	kg	21	25	32	50	74	89	131	204	290	391	541	631	812	1183	2030	1193	4600	8500
BW Wt.	lbs	40	46	58	91	152	180	259	425	584	811	1146	1349	1720	2534	4037	4385	10198	15545
	kg	18	21	26	41	69	82	118	193	265	369	521	613	782	1152	1835	1993	4625	8550

Note: Dimensions: Inches/Millimeters - Weights: Pounds/Kilograms. Larger sizes available on request. Dimensions are subject to change without notice.

Cast Steel Bolted Bonnet Gates

Styles: CB2, CB3, & CB4/2

Class 300 - Sizes: 2" thru 36"

Pressure Class Range: 150 thru 1500

Design and Manufacturing Standards

Valve Design: ASME B16.34/API 600

Flange Dimensions: ASME B16.5, B16.47 (Series A)

Face-to-Face Dimensions: ASME B16.10

Tested in Accordance with: API 598

Recommended Spare Parts*

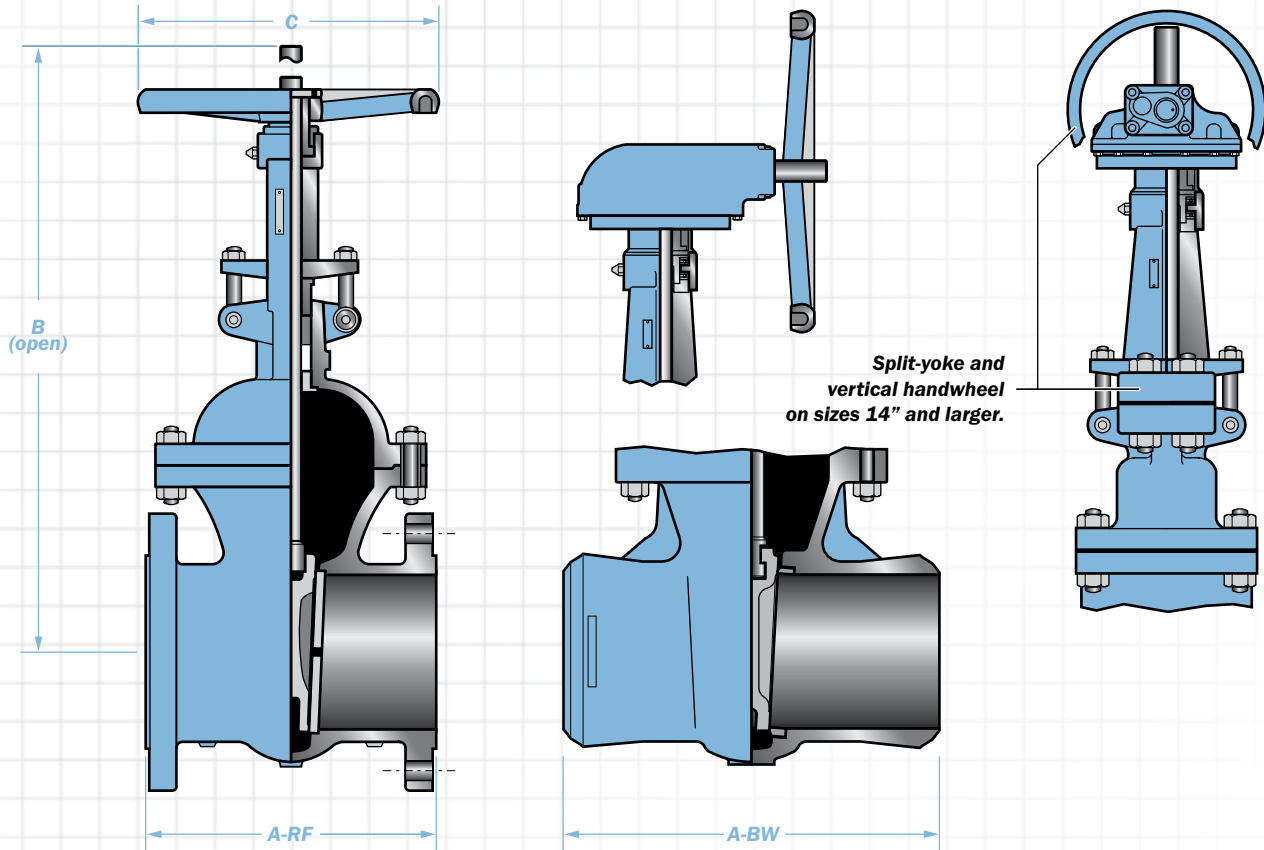

Typical Bill of Materials (See page 5 for available materials.)

Component	CB2	CB3	CB4/2	Component	CB2	CB3	CB4/2
Body	ASTM A216-WCB			Gland Flange	ASTM A216-WCB		
Seat Rings	ASTM A105/HF			Gland Bolt Pins	ASTM A36		
Wedge 2" - 3"	ASTM A276-410	ASTM A216-WCB/HF	ASTM A351-CF8M/A276-316	Gland Bolts	ASTM A307-B		
Wedge 4" & larger	ASTM A216-WCB w/13% Chrome	ASTM A216-WCB/HF	ASTM A276-316	Gland Nuts	ASTM A194-2H		
Stem	ASTM A182-F6a		ASTM A182-316	Nameplate Rivets	Stainless Steel - Commercial		
Yoke & Bonnet	ASTM A216-WCB			Grease Fitting	Carbon Steel - Commercial		
*Bonnet Gasket	Spiral Wound 316 Stainless Steel/Graphite			Stem Nut	ASTM A439-D2		
Bonnet Nuts	ASTM A194-2H		ASTM A194-2HM	Yoke Bushing	ASTM A536 (65-45-12)		
Bonnet Studs	ASTM A193-B7		ASTM A193-B7M	Handwheel	ASTM A536 (65-45-12)		
Back Seat Bushing	ASTM A276-410		ASTM A276-316	Handwheel Nut	ASTM A536 (65-45-12)		
*Packing	Graphite w/Braided Carbon Fiber End Rings			Set Screw	ASTM A193-B6		
Gland	ASTM A276-410		ASTM A276-316	Spacer Ring	ASTM A276-410		

Class 300

Size	nps	2	2.5	3	4	5	6	8	10	12	14	16	18	20	24	30	36
	dn	50	65	80	100	125	150	200	250	300	350	400	450	500	600	750	900
A-RF	in	8.5	9.5	11.1	12.0	15.0	15.9	16.5	18.0	19.75	30.0	33.0	36.0	39.0	45.0	55.0	68.0
	mm	216	241	282	305	381	404	419	457	502	762	838	914	991	1143	1397	1727
A-BW	in	8.5	9.5	11.1	12.0	15.0	15.9	16.5	18.0	19.75	30.0	33.0	36.0	39.0	45.0	55.0	68.0
	mm	216	241	282	305	381	404	419	457	502	762	838	914	991	1143	1397	1727
B	in	17.2	19.1	20.0	24.0	29.6	33.0	41.1	49.3	57.0	67.0	73.1	82.2	95.5	104.7	136.3	169.8
	mm	437	485	508	610	752	838	1044	1252	1448	1702	1857	2088	2426	2659	3462	4312
C	in	8.0	10.0	10.0	12.0	15.0	16.0	18.0	20.0	22.0	18.1	18.1	21.3	21.3	24.0	31.9	30.0
	mm	203	254	254	305	381	406	457	508	559	460	460	451	541	610	810	760
RF Wt.	lbs	64	88	112	175	258	340	542	816	1072	1764	2183	2867	3682	5645	9702	15104
	kg	29	40	51	80	117	155	246	371	487	802	992	1303	1674	2566	4410	6850
BW Wt.	lbs	51	68	86	154	207	269	430	620	871	1323	1830	2381	3109	4873	8350	11003
	kg	23	31	39	70	94	122	195	282	396	601	832	1082	1413	2215	3795	4990

Note: Dimensions: Inches/Millimeters - Weights: Pounds/Kilograms. Larger sizes available on request. Dimensions are subject to change without notice.

Cast Steel Bolted Bonnet Gates

Styles: CB2, CB3, & CB4/2

Class: 600 - Sizes: 2" thru 24"

Pressure Class Range: 150 thru 1500

Design and Manufacturing Standards

Valve Design: ASME B16.34/API 600

Flange Dimensions: ASME B16.5, B16.47 (Series A)

Face-to-Face Dimensions: ASME B16.10

Tested in Accordance with: API 598

Recommended Spare Parts*

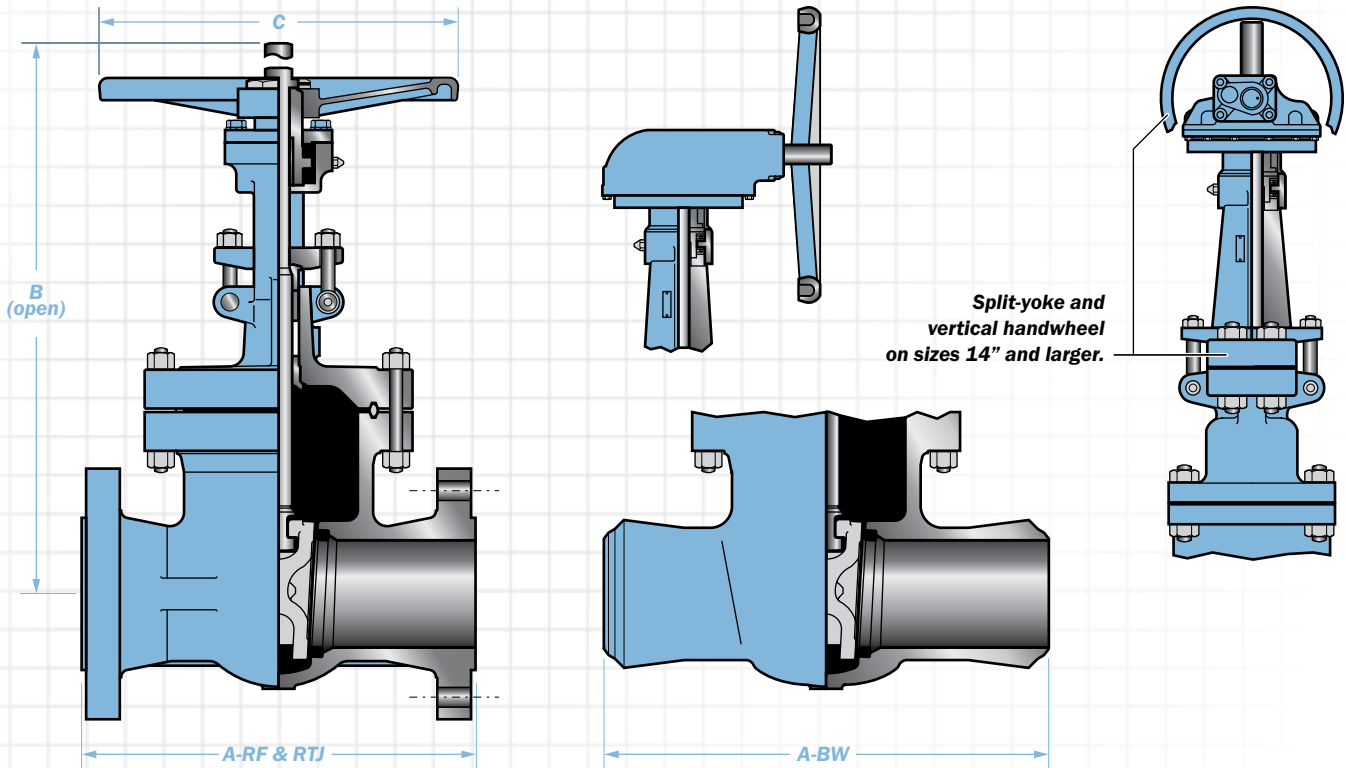

Typical Bill of Materials (See page 5 for available materials.)

Component	CB2	CB3	CB4/2	Component	CB2	CB3	CB4/2
Body	ASTM A216-WCB			Gland Flange	ASTM A216-WCB		
Seat Rings	ASTM A105/HF			Gland Bolt Pins	ASTM A36		
Wedge 2" - 3"	ASTM A276-410	ASTM A216-WCB/HF	ASTM A351-CF8M/A276-316	Gland Bolts	ASTM A307-B		
Wedge 4" & larger	ASTM A216-WCB w/13% Chrome	ASTM A216-WCB/HF	ASTM A276-316	Gland Nuts	ASTM A194-2H		
Stem	ASTM A182-F6a		ASTM A182-316	Nameplate	Stainless Steel 304		
Yoke & Bonnet	ASTM A216-WCB			Nameplate Rivets	Stainless Steel - Commercial		
*Bonnet Gasket	Soft Steel Ring Joint			Grease Fitting	Carbon Steel - Commercial		
Bonnet Nuts	ASTM A194-2H		ASTM A194-2HM	Stem Nut	ASTM A439-D2		
Bonnet Studs	ASTM A193-B7		ASTM A193-B7M	Yoke Bushing	ASTM A536 (65-45-12)		
Back Seat Bushing	ASTM A276-410		ASTM A276-316	Handwheel	ASTM A536 (65-45-12)		
*Packing	Graphite w/Braided Carbon Fiber End Rings			Handwheel Nut	ASTM A536 (65-45-12)		
Gland	ASTM A276-410		ASTM A276-316	Set Screw	ASTM A193-B6		
				Spacer Ring	ASTM A276-410		

Class 600

Size	nps dn	2	2.5	3	4	5	6	8	10	12	14	16	18	20	24
		50	65	80	100	125	150	200	250	300	350	400	450	500	600
A-RF	in	11.5	13.0	14.0	17.0	20.0	22.0	26.0	31.0	33.0	35.0	39.0	43.0	47.0	55.0
	mm	292	330	356	432	508	559	660	787	838	889	991	1092	1194	1397
A-BW	in	11.5	13.0	14.0	17.0	20.0	22.0	26.0	31.0	33.0	35.0	39.0	43.0	47.0	55.0
	mm	292	330	356	432	508	559	660	787	838	889	991	1092	1194	1397
A-RTJ	in	11.62	13.12	14.12	17.12		22.12	26.12	31.12	33.12	35.12	39.12	43.12	47.25	55.38
	mm	295	333	359	435		562	664	791	841	892	994	1095	1200	1406
B	in	18.3	19.9	21.7	26.9	31.6	36.5	44.0	52.8	61.4	64.8	71.7	79.3	104.8	116.9
	mm	465	505	551	683	803	927	1118	1341	1560	1646	1821	2014	2662	2970
C	in	10.0	10.0	12.0	14.0	18.0	20.0	24.0	27.0	27.0	24.0	24.0	24.0	31.5	35.4
	mm	254	254	305	356	457	508	610	686	686	610	610	610	800	900
RFRTJ	lbs	97	132	176	320	520	680	1150	1715	2440	3150	4415	5010	6853	10337
Wt.	kg	44	60	80	145	236	309	523	780	1109	1432	2007	2277	3108	4688
BW	lbs	79	120	152	270	430	580	1020	1430	1950	2695	3800	5010	5640	8595
	kg	36	55	69	123	195	264	464	650	886	1225	1727	2277	2558	3898

Note: Dimensions: Inches/Millimeters - Weights: Pounds/Kilograms. Larger sizes available on request. Dimensions are subject to change without notice.

Cast Steel Bolted Bonnet Gates

Styles: CB2, CB3, & CB4/2

Class: 900 - Sizes: 2" thru 18"

Pressure Class Range: 150 thru 1500

Design and Manufacturing Standards

Valve Design: ASME B16.34/API 600

Flange Dimensions: ASME B16.5, B16.47 (Series A)

Face-to-Face Dimensions: ASME B16.10

Tested in Accordance with: API 598

Recommended Spare Parts*

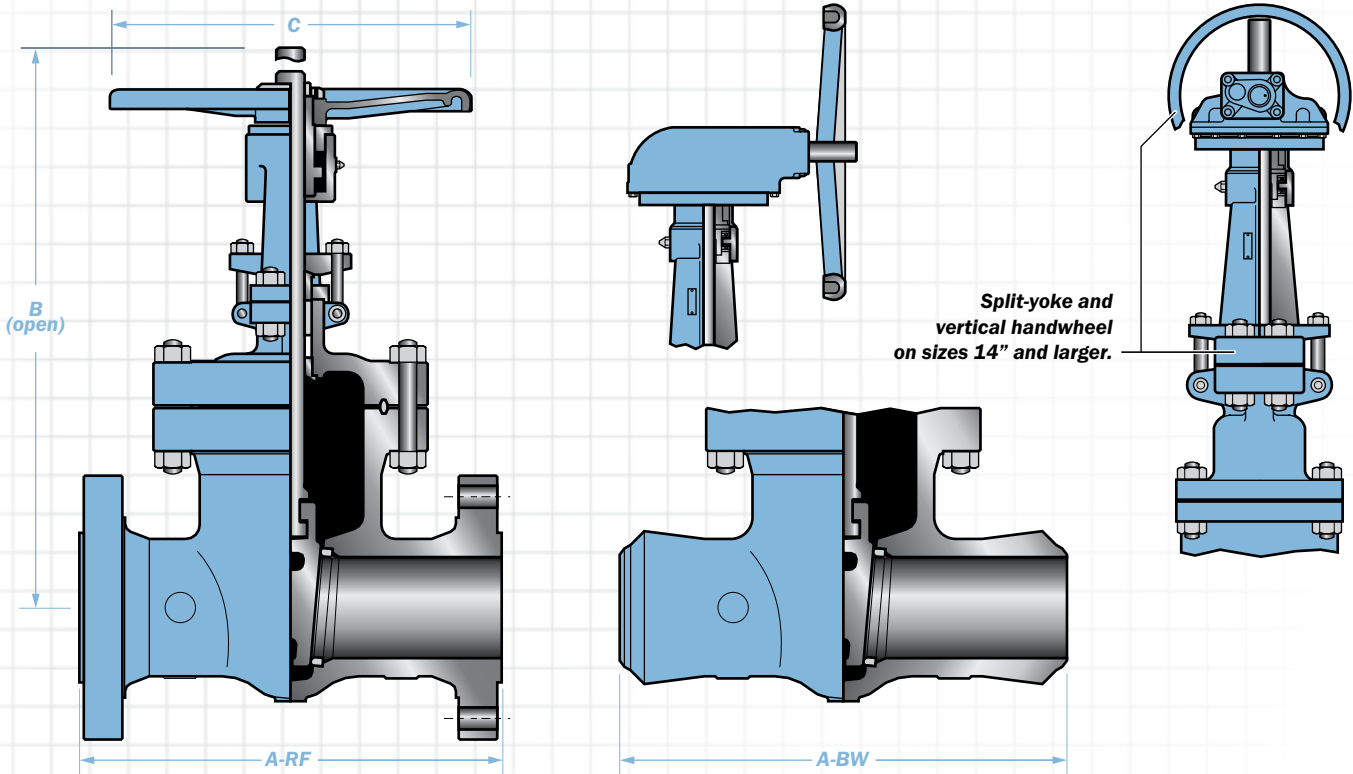

Typical Bill of Materials (See page 5 for available materials.)

Component	CB2	CB3	CB4/2	Component	CB2	CB3	CB4/2
Body	ASTM A216-WCB			Gland Flange	ASTM A216-WCB		
Seat Rings	ASTM A105/HF			Gland Bolt Pins	ASTM A36		
Wedge 2" - 3"	ASTM A276-410	ASTM A216-WCB/HF	ASTM A351-CF8M/A276-316	Gland Bolts	ASTM A307-B		
Wedge 4" & larger	ASTM A216-WCB w/13% Chrome	ASTM A216-WCB/HF	ASTM A276-316	Gland Nuts	ASTM A194-2H		
Stem	ASTM A182-F6a			Nameplate	Stainless Steel 304		
Yoke & Bonnet	ASTM A216-WCB			Nameplate Rivets	Stainless Steel - Commercial		
*Bonnet Gasket	Soft Steel Ring Joint			Grease Fitting	Carbon Steel - Commercial		
Bonnet Nuts	ASTM A194-2H		ASTM A194-2HM	Stem Nut	ASTM A439-D2		
Bonnet Studs	ASTM A193-B7		ASTM A193-B7M	Yoke Bushing	ASTM A536 (65-45-12)		
Back Seat Bushing	ASTM A276-410		ASTM A276-316	Handwheel	ASTM A536 (65-45-12)		
*Packing	Graphite w/Braided Carbon Fiber End Rings			Handwheel Nut	ASTM A536 (65-45-12)		
Gland	ASTM A276-410		ASTM A276-316	Set Screw	ASTM A193-B6		
				Spacer Ring	ASTM A276-410		

Class 900

Size	nps	2	2.5	3	4	6	8	10	12	14	16	18
	dn	50	65	75	100	150	200	250	300	350	400	450
A-RF	in	14.5	16.5	15.0	18.0	24.0	29.0	33.0	38.0	40.5	44.5	48.0
	mm	368	419	381	457	610	737	838	965	1029	1130	1219
A-BW	in	14.5	16.5	15.0	18.0	24.0	29.0	33.0	38.0	40.5	44.5	48.0
	mm	368	419	381	457	610	737	838	965	1029	1130	1219
A-RTJ	in	14.62	16.62	15.12	18.12	24.12	29.12	33.12	38.12	40.88	44.88	48.5
	mm	371	422	384	460	612	740	841	968	1038	1140	1232
B	in	21.7	26.0	23.7	27.6	38.4	45.5	52.6	59.8	74.9	80.7	88.8
	mm	551	660	602	701	975	1156	1336	1519	1902	2051	2256
C	in	12.0	15.0	14.0	16.0	24.0	27.0	30.0	30.0	24.0	24.0	30.0
	mm	305	381	356	406	610	686	762	762	610	610	762
RF	lbs	135	175	255	453	913	1705	2387	3600	4895	6615	8533
Wt.	kg	61	385	116	206	415	775	1085	1636	2220	3000	3870
BW	lbs	125	155	213	396	807	1465	1724	2790	4168	5656	7277
Wt.	kg	57	70	97	180	367	665	784	1268	1890	2565	3300

Note: Dimensions: Inches/Millimeters - Weights: Pounds/Kilograms. Larger sizes available on request. Dimensions are subject to change without notice.

Cast Steel Bolted Bonnet Gates

Styles: CB2, CB3, & CB4/2

Class: 1500 - Sizes: 2" thru 18"

Pressure Class Range: 150 thru 1500

Design and Manufacturing Standards

Valve Design: ASME B16.34/API 600

Flange Dimensions: ASME B16.5, B16.47 (Series A)

Face-to-Face Dimensions: ASME B16.10

Tested in Accordance with: API 598

Recommended Spare Parts*

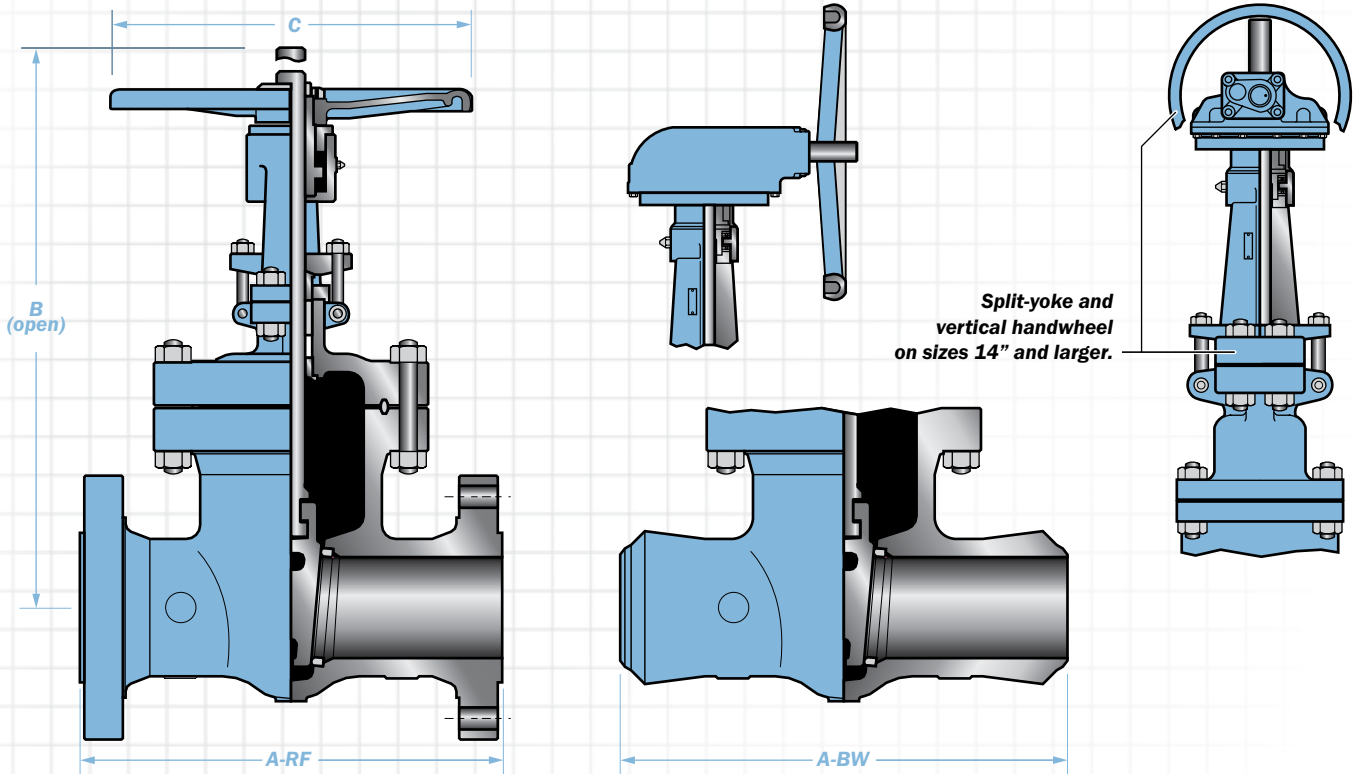

Typical Bill of Materials (See page 5 for available materials.)

Component	CB2	CB3	CB4/2	Component	CB2	CB3	CB4/2
Body	ASTM A216-WCB			Gland Flange	ASTM A216-WCB		
Seat Rings	ASTM A105/HF			Gland Bolt Pins	ASTM A36		
Wedge 2" - 3"	ASTM A276-410	ASTM A216-WCB/HF	ASTM A351-CF8M/A276-316	Gland Bolts	ASTM A307-B		
Wedge 4" & larger	ASTM A216-WCB w/13% Chrome	ASTM A216-WCB/HF	ASTM A276-316	Gland Nuts	ASTM A194-2H		
Stem	ASTM A182-F6a		ASTM A182-316	Nameplate	Stainless Steel 304		
Yoke & Bonnet	ASTM A216-WCB			Nameplate Rivets	Stainless Steel - Commercial		
*Bonnet Gasket	Soft Steel Ring Joint			Grease Fitting	Carbon Steel - Commercial		
Bonnet Nuts	ASTM A194-2H		ASTM A194-2HM	Stem Nut	ASTM A439-D2		
Bonnet Studs	ASTM A193-B7		ASTM A193-B7M	Yoke Bushing	ASTM A536 (65-45-12)		
Back Seat Bushing	ASTM A276-410		ASTM A276-316	Handwheel	ASTM A536 (65-45-12)		
*Packing	Graphite w/Braided Carbon Fiber End Rings			Handwheel Nut	ASTM A536 (65-45-12)		
Gland	ASTM A276-410		ASTM A276-316	Set Screw	ASTM A193-B6		
				Spacer Ring	ASTM A276-410		

Class 1500

Size	nps	2	2.5	3	4	6	8	10	12	14	16	18
	dn	50	65	75	100	150	200	250	300	350	400	450
A-RF	in	14.5	16.5	18.5	21.5	27.8	32.75	39.0	44.5	49.5	54.5	60.5
	mm	368	419	470	546	706	832	991	1130	1257	1384	1536
A-BW	in	14.5	16.5	18.5	21.5	27.8	32.75	39.0	44.5	49.5	54.5	60.5
	mm	368	419	470	546	706	832	991	1130	1257	1384	1536
A-RTJ	in	14.62	16.62	18.62	21.62	28.0	33.13	39.38	45.12	50.25	55.38	61.38
	mm	371	422	473	549	711	841	1000	1146	1276	1406	1559
B	in	21.7	26.0	28.5	32.6	39.3	48.1	66.5	82.3	85.1	97.9	108.7
	mm	551	660	724	828	998	1223	1688	2090	2162	2486	2762
C	in	12.0	15.0	16.0	18.0	27.0	30.0	27.9	27.9	30.0	30.0	30.0
	mm	305	381	406	457	686	762	710	710	762	762	762
RF	lbs	128	163	209	423	978	1625	4412	8414	9074	13324	19845
Wt.	kg	58	74	95	192	445	739	2001	3816	4115	6950	9000
BW	lbs	106	137	174	352	870	1650	3541	7080	7056	13230	17067
Wt.	kg	48	62	79	160	395	750	1606	3211	3200	6000	7740

Note: Dimensions: Inches/Millimeters - Weights: Pounds/Kilograms. Larger sizes available on request. Dimensions are subject to change without notice.

Valveuable Qualities...

- **R**eliable
- **E**xcellent Warranty
- **L**eading Manufacturer
- **I**ntegrity
- **A**vailability
- **B**uilt to Last
- **L**arge Inventory
- **E**xpertise
- **S**tandardized Tests
- **O**ptimum Performance
- **U**ncompromized Construction
- **R**ecognized Name
- **C**ustomer Service
- **E**xceptional Quality

...but we really don't like to brag.

 **Newmans**
The Reliable Source

Toll Free: 800.231.3505
www.NewmansValve.com



Newmans manufactures a complete line of **Newco** and **OIC** valve products in a full range of sizes, classes, and materials. The new addition of **Cooper's** complete product line will now allow us to better serve your severe service needs.

Newmans has been supplying quality valves to the world's hydrocarbon, pulp & paper, marine, power, and general industries for more than 60 years. **Newmans** manufactures and inventories gate, globe, check, ball, and specialty valves in sizes from 1/2" thru 60" in diameter and in pressure classes from 125 thru 4500 lbs. in most alloys.

Newmans' world-wide production facilities are certified to the requirements of the ISO 9001:2000 Standard and are compliant to the industry standards of API, ASTM and ASME. All **Newmans** products are manufactured, inspected, and tested in accordance to the most rigid quality standards as well as any specific customer requirements.

So, whether it's exotic alloys for corrosive applications or metal seated ball valves for severe service applications, **Newmans** is "The Reliable Source" for all your valve needs.

- Engineered solutions
- Complete alloy coverage
- Ready-to-ship inventories
- Competitive factory lead times
- Sizes: 1/2" thru 60" & Classes: 125 thru 4500

Newco®

Cast Steel Bolted Bonnet Globe Valves

Manufactured by Newmans™

Sizes: 2" thru 14" • Pressure Class: 150 thru 1500



Typical Newco Cast Steel Bolted Bonnet Globe Valve Expanded View

1. Body: Newco cast steel bodies provide low resistance flow and optimum strength and performance.

2. Bonnet: Newco bonnet assemblies are built to the same standards as the bodies.

3. Back Seat Bushing: The back seat, when engaged with the stem head, provides a stable shutoff to the stuffing box which isolates the packing from flow exposure.

4. Stem: The stem inserts vertically into the disc.

5. Lock Groove: The lock groove receives the split lock ring which allows the disc nut to lift the disc during cycling.

6. Split Ring: The split ring allows the disc nut to lift the disc during cycling.

7. Disc: Newmans plug type disc is machined to the tightest tolerances to ensure trouble free shutoff and cycling.

8. Disc Nut: The disc nut, in conjunction with the split lock ring, secures the disc to the stem.

9. Gland: Compresses the packing to create a stem seal above the back seat, between the bonnet and stem.

10. Gland Flange: Applies pressure to the gland for accurate packing compression.

11. & 12. Gland Bolts & Nuts: The gland bolt and nut allows for easy adjustments for packing compression.

13. Gland Bolt Pin: The gland bolt pin secures the gland bolts to the yoke & bonnet.

14. Packing: The packing creates a seal above the back seat, between the bonnet and stem.

15. Stuffing Box: The stuffing box contains the packing.

16. Stem Nut: The stem nut provides a precision guide for proper stem alignment.

17. Handwheel: The handwheel cycles the valve.

18. Handwheel Nut: The handwheel nut secures the handwheel to the bonnet assembly.

19. Handwheel Washer: The washer helps to prevent loosening or distributes pressure evenly.

20. Bonnet Gasket: The bonnet gasket creates a leakproof seal between the bonnet and body.

21. & 22. Bonnet Studs & Nuts: The bonnet studs and nuts secure the bonnet to the body.

23. Seat Ring: To ensure a stable shutoff, the seat rings is aligned and seal-welded into the valve, then precision ground for optimal seating.

24. Disc Guide: The disc guides provide a stable track for keeping the disc aligned with the seat during cycling.

25. Spacer Ring: Assists the packing rings in creating a seal above the back seat, between the bonnet and stem.

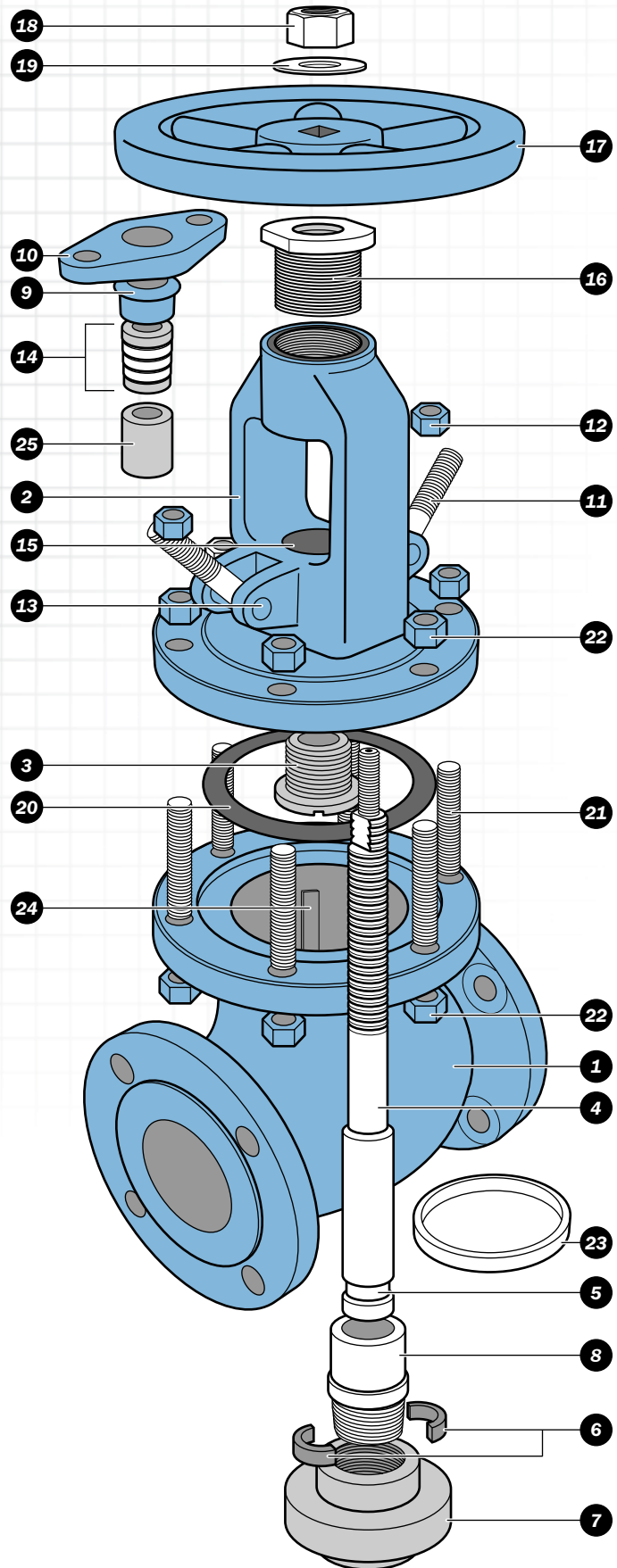

Cast Steel Bolted Bonnet Globes

Styles: CB2, CB3, & CB4/2

Class: 150 - Sizes: 2" thru 14"

Pressure Class Range: 150 thru 1500

Design and Manufacturing Standards

Valve Design: ASME B16.34/API 600

Flange Dimensions: ASME B16.5, B16.47 (Series A)

Face-to-Face Dimensions: ASME B16.10

Tested in Accordance with: API 598

Recommended Spare Parts*

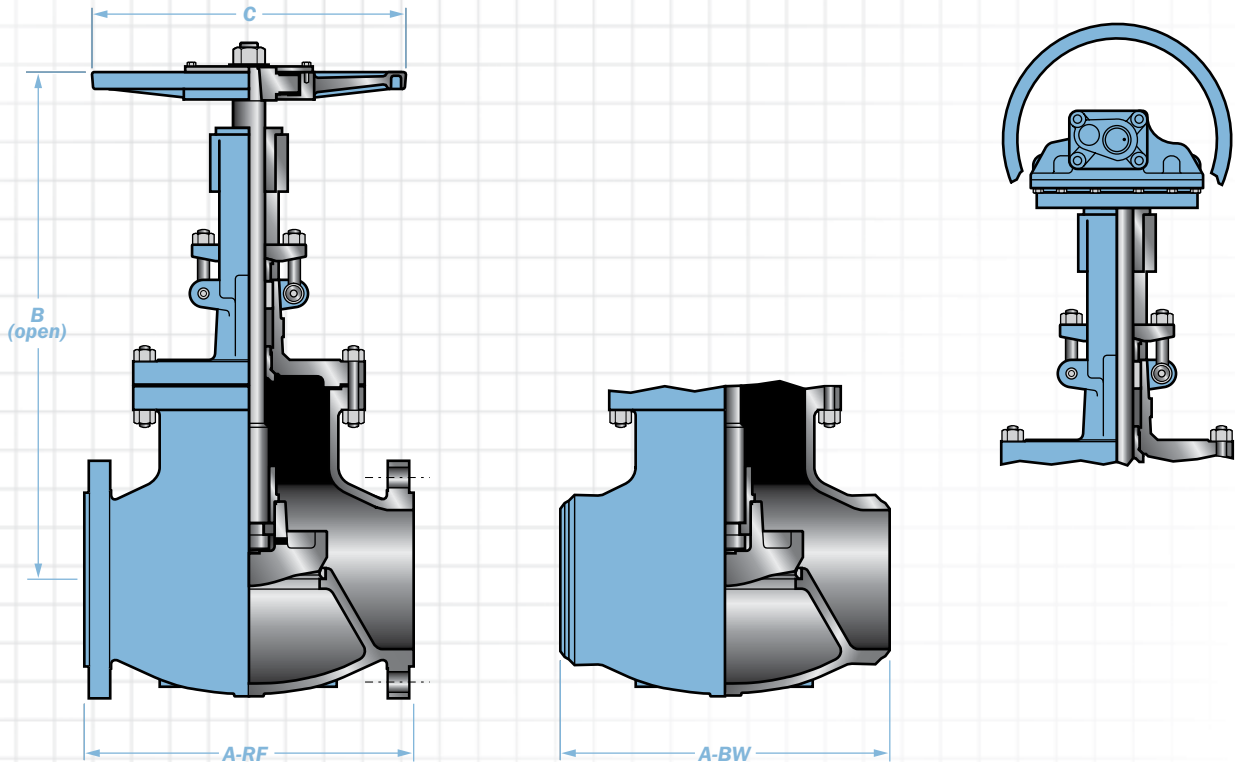

Typical Bill of Materials (See page 5 for available materials.)

Component	CB2	CB3	CB4/2	Component	CB2	CB3	CB4/2
Body	ASTM A216-WCB**			Gland Bolt Pins	ASTM A36		
Disc 2" thru 4"	ASTM A276-410	ASTM A216-WCB/ HF	ASTM A276-316	Gland Nuts	ASTM A194-2H	ASTM A194-2HM	
Disc 5" and larger	ASTM A216-WCB/ 13% Chrome		ASTM A216- WCB/316	Gland Bolts	ASTM A307-B		
Stem	ASTM A276-410		ASTM A276-316	Seat Ring	ASTM A105/HF (6" & larger)		
Bonnet	ASTM A216-WCB			Split Ring	ASTM A276-410		
*Bonnet Gasket	Spiral Wound 316 Stainless Steel/Graphite			Nameplate	ASTM A666-304		
Bonnet Nuts	ASTM A194-2H	ASTM A194-2HM		Nameplate Rivets	Commercial		
Bonnet Studs	ASTM 193-B7	ASTM A193-B7M		Disc Nut	ASTM A276-410	ASTM A276-316	
Back Seat Bushing	ASTM A276-410	ASTM A276-316		Stem Nut	ASTM A439-D2		
*Packing	Graphite W/Braided Carbon Fiber End Rings			Handwheel Washer	ASTM A36		
Gland	ASTM A276-410	ASTM A276-316		Handwheel Nut	ASTM A36		
Gland Flange	ASTM A276-WCB			Handwheel	ASTM A536 (65-45-12)		
				Spacer Ring	N/A		

Class 150

Size	nps	2	2.5	3	4	5	6	8	10	12	14
	dn	50	65	75	100	125	150	200	250	300	350
A-RF	in	8.0	8.5	9.5	11.5	14.0	16.0	19.5	24.5	27.5	31.0
	mm	203	216	241	292	356	406	495	622	699	787
A-BW	in	8.0	8.5	9.5	11.5	14.0	16.0	19.5	24.5	27.5	31.0
	mm	203	216	241	292	356	406	495	622	699	787
B	in	14.9	15.8	16.6	19.9	21.8	22.4	26.5	30.6	34.8	41.4
	mm	378	401	422	505	554	569	673	777	884	1052
C	in	8.0	10.0	10.0	12.0	14.0	16.0	18.0	22.0	24.0	27.0
	mm	203	254	254	305	356	406	457	610	610	610
RF	lbs	51	73	93	137	192	243	419	507	948	1276
Wt.	kg	23	33	42	62	87	110	190	276	476	625
BW	lbs	51	73	93	137	192	243	419	507	948	1276
	kg	23	33	42	62	87	110	190	276	476	625

Note: Dimensions: Inches/Millimeters - Weights: Pounds/Kilograms. Larger sizes available on request. Dimensions are subject to change without notice.

** ASTM A216-WCB/HF for 2" to 4".

Rev: 032307.01

Cast Steel Bolted Bonnet Globes

Styles: CB2, CB3, & CB4/2

Class: 300 - Sizes: 2" thru 14"

Pressure Class Range: 150 thru 1500

Design and Manufacturing Standards

Valve Design: ASME B16.34/API 600

Flange Dimensions: ASME B16.5, B16.47 (Series A)

Face-to-Face Dimensions: ASME B16.10

Tested in Accordance with: API 598 & API RP591

Recommended Spare Parts**

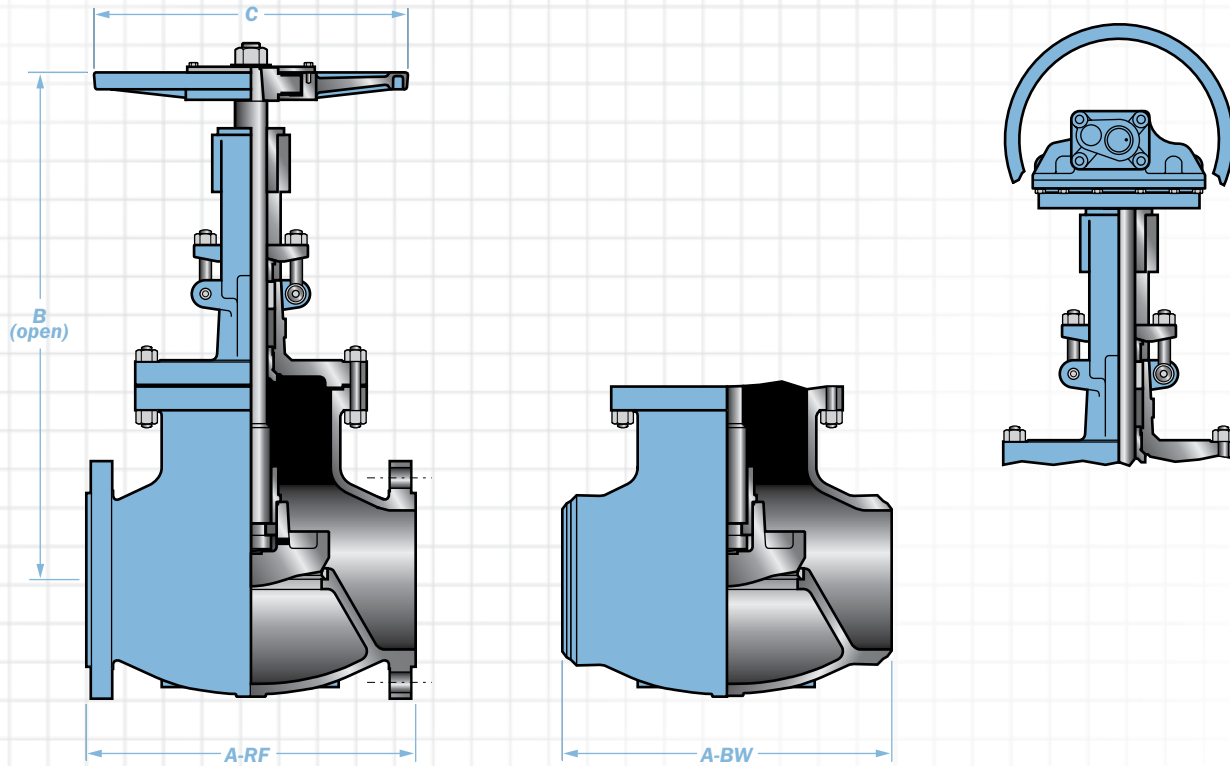

Typical Bill of Materials (See page 5 for available materials.)

Component	CB2	CB3	CB4/2	Component	CB2	CB3	CB4/2
Body	ASTM A216-WCB**			Gland Bolt Pins	ASTM A36		
Disc 2" thru 4"	ASTM A276-410	ASTM A216-WCB/ HF	ASTM A276-316	Gland Nuts	ASTM A194-2H	ASTM A194-2HM	
Disc 5" and larger	ASTM A216-WCB/ 13% Chrome		ASTM A216- WCB/316	Gland Bolts	ASTM A307-B		ASTM A193-B7M
Stem	ASTM A276-410		ASTM A276-316	Seat Ring	ASTM A105/HF		
Bonnet	ASTM A216-WCB			Split Ring	ASTM A276-410		
*Bonnet Gasket	Spiral Wound 316 Stainless Steel/Graphite			Nameplate	ASTM A666-304		
Bonnet Nuts	ASTM A194-2H	ASTM A194-2HM		Nameplate Rivets	Commercial		
Bonnet Studs	ASTM 193-B7	ASTM A193-B7M		Disc Nut	ASTM A276-410	ASTM A276-316	
Back Seat Bushing	ASTM A276-410	ASTM A276-316		Stem Nut	ASTM A439-D2		
*Packing	Graphite W/Braided Carbon Fiber End Rings			Handwheel Washer	ASTM A36		
Gland	ASTM A276-410	ASTM A276-316		Handwheel Nut	ASTM A36		
Gland Flange	ASTM A276-WCB			Handwheel	ASTM A536 (65-45-12)		
				Spacer Ring	ASTM A276-410		

Class 300

Size	nps	2	2.5	3	4	5	6	8	10	12	14
	dn	50	65	75	100	125	150	200	250	300	350
A-RF	in	10.5	11.5	12.5	14.0	15.75	17.5	22.0	24.5	28.0	33.0
	mm	267	292	318	357	400	445	559	622	711	838
A-BW	in	10.5	11.5	12.5	14.0	15.75	17.5	22.0	24.5	28.0	33.0
	mm	267	292	318	357	400	445	559	622	711	838
B	in	16.9	17.8	19.2	23.0	27.4	30.6	36.2	40.8	47.3	54.3
	mm	429	452	488	584	696	777	919	1036	1201	1379
C	in	10.0	10.0	12.0	14.0	14.0	18.0	24.0	24.0	27.0	24.0
	mm	254	254	305	356	406	457	610	610	686	610
RF	lbs	75.0	100.0	130.0	203.0	294.0	421.0	715	1015	1500	2446
Wt.	kg	34	45	59	92	134	191	325	461	682	1112
BW	lbs	55	79	101	163	242	355	566	770	1218	1996
Wt.	kg	25	36	46	74	110	161	257	350	554	907

Note: Dimensions: Inches/Millimeters - Weights: Pounds/Kilograms. Larger sizes available on request. Dimensions are subject to change without notice.
** ASTM A216-WCB/HF for 2" to 4".
Rev: 032307.01

Cast Steel Bolted Bonnet Globes

Styles: **CB2, CB3, & CB4/2**

Class: **600 - Sizes: 2" thru 8"**

Pressure Class Range: 150 thru 1500

Design and Manufacturing Standards

Valve Design: ASME B16.34/API 600

Flange Dimensions: ASME B16.5, B16.47 (Series A)

Face-to-Face Dimensions: ASME B16.10

Tested in Accordance with: API 598 & API RP591

Recommended Spare Parts**

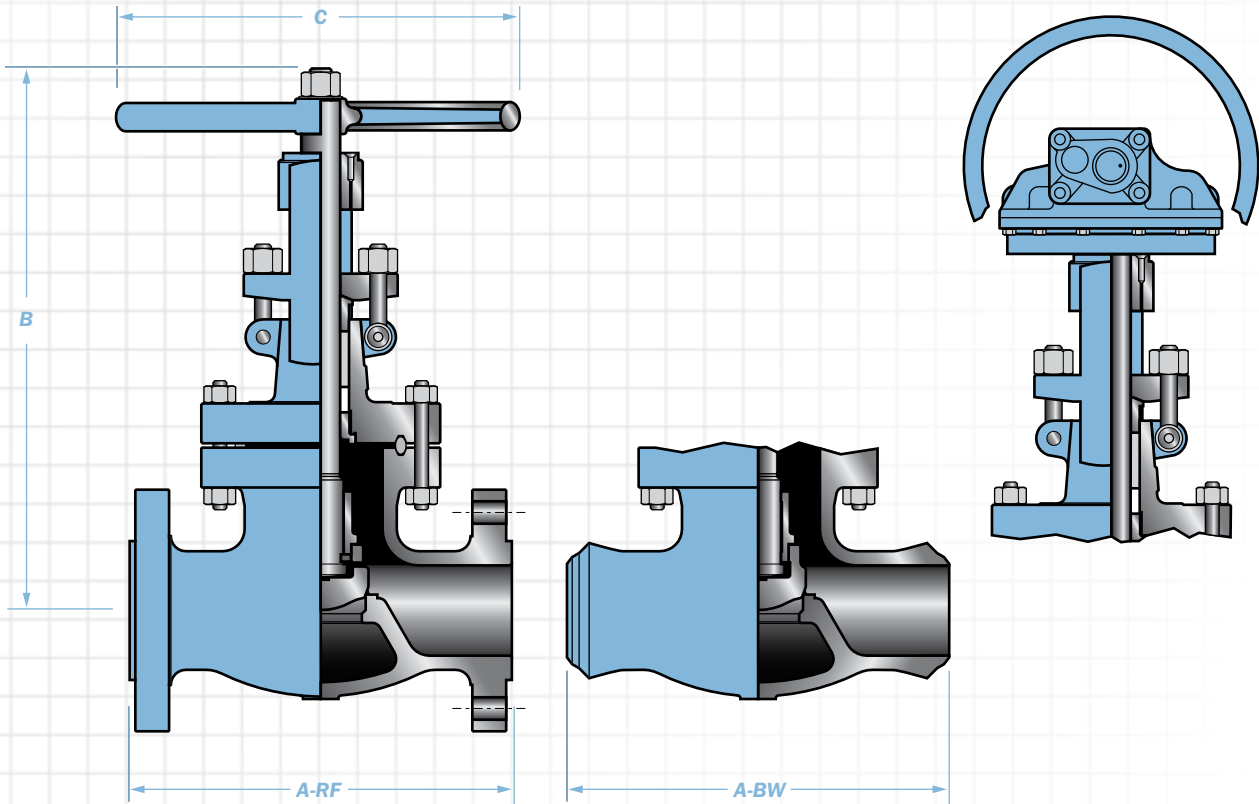

Typical Bill of Materials (See page 5 for available materials.)

Component	CB2	CB3	CB4/2	Component	CB2	CB3	CB4/2
Body	ASTM A216-WCB/HF			Gland Bolt Pins	ASTM A36		
Disc 2" thru 4"	ASTM A276-410	ASTM A216-WCB/ HF	ASTM A276-316	Gland Nuts	ASTM A194-2H	ASTM A194-2HM	
Disc 5" and larger	ASTM A216-WCB/ 13% Chrome		ASTM A216- WCB/316	Gland Bolts	ASTM A307-B		ASTM A193-B7M
Stem	ASTM A276-410		ASTM A276-316	Seat Ring	Integral		
Bonnet	ASTM A216-WCB			Split Ring	ASTM A276-410		
*Bonnet Gasket	Soft Steel Ring Joint			Nameplate	ASTM A666-304		
Bonnet Nuts	ASTM A194-2H	ASTM A194-2HM		Nameplate Rivets	Commercial		
Bonnet Studs	ASTM 193-B7	ASTM A193-B7M		Disc Nut	ASTM A276-410	ASTM A276-316	
Back Seat Bushing	ASTM A276-410	ASTM A276-316		Stem Nut	ASTM A439-D2		
*Packing	Graphite W/Braided Carbon Fiber End Rings			Handwheel Washer	ASTM A36		
Gland	ASTM A276-410	ASTM A276-316		Handwheel Nut	ASTM A36		
Gland Flange	ASTM A276-WCB			Handwheel	ASTM A536 (65-45-12)		
				Spacer Ring	ASTM A276-410		

Class 600

Size	nps	2	2.5	3	4	6	8
	dn	50	65	75	100	150	200
A-RF	in	11.5	13.0	14.0	17.0	22.0	26.0
	mm	292	325	256	435	559	660
A-BW	in	11.5	13.0	14.0	17.0	22.0	26.0
	mm	292	325	256	435	559	660
B	in	18.4	20.0	24.4	29.0	37.9	44.7
	mm	467	508	620	737	963	1135
C	in	10.0	10.0	14.0	18.0	24.0	24.0
	mm	254	254	356	457	610	610
RF	lbs	90	130	170	313	778	1245
Wt.	kg	41	59	77	142	354	566
BW	lbs	79	110	141	256	640	961
Wt.	kg	36	50	64	116	291	437

Note: Dimensions: Inches/Millimeters - Weights: Pounds/Kilograms. Larger sizes available on request. Dimensions are subject to change without notice.

Cast Steel Bolted Bonnet Globes

Styles: CB2, CB3, & CB4/2

Class: 900 - Sizes: 2" thru 8"

Pressure Class Range: 150 thru 1500

Design and Manufacturing Standards

Valve Design: ASME B16.34/API 600

Flange Dimensions: ASME B16.5, B16.47 (Series A)

Face-to-Face Dimensions: ASME B16.10

Tested in Accordance with: API 598

Recommended Spare Parts*

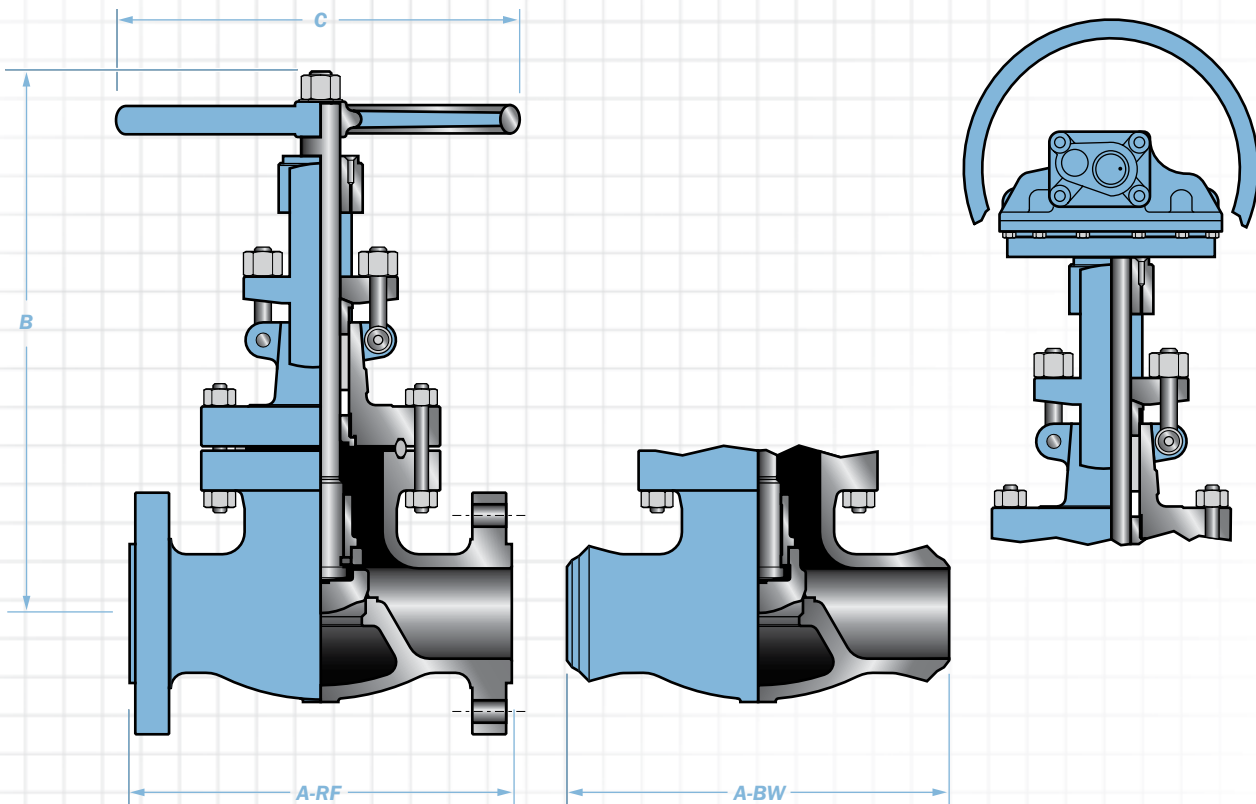

Typical Bill of Materials (See page 5 for available materials.)

Component	CB2	CB3	CB4/2	Component	CB2	CB3	CB4/2
Body	ASTM A216-WCB/HF			Gland Bolt Pins	ASTM A36		
Disc 2" thru 4"	ASTM A276-410	ASTM A216-WCB/ HF	ASTM A276-316	Gland Nuts	ASTM A194-2H	ASTM A194-2HM	
Disc 5" and larger	ASTM A216-WCB/ 13% Chrome		ASTM A216- WCB/316	Gland Bolts	ASTM A307-B	ASTM A193-B7M	
Stem	ASTM A276-410		ASTM A276-316	Seat Ring	Integral		
Bonnet	ASTM A216-WCB			Split Ring	ASTM A276-410		
*Bonnet Gasket	Soft Steel Ring Joint			Nameplate	ASTM A666-304		
Bonnet Nuts	ASTM A194-2H	ASTM A194-2HM		Nameplate Rivets	Commercial		
Bonnet Studs	ASTM 193-B7	ASTM A193-B7M		Disc Nut	ASTM A276-410	ASTM A276-316	
Back Seat Bushing	ASTM A276-410	ASTM A276-316		Stem Nut	ASTM A439-D2		
*Packing	Graphite W/Braided Carbon Fiber End Rings			Handwheel Washer	ASTM A36		
Gland	ASTM A276-410	ASTM A276-316		Handwheel Nut	ASTM A36		
Gland Flange	ASTM A276-WCB			Handwheel	ASTM A536 (65-45-12)		
				Spacer Ring	ASTM A276-410		

Class 900

Size	nps	2	3	4	6	8
	dn	50	75	100	150	200
A-RF	in	14.5	15.0	18.0	24.0	29.0
	mm	368	381	457	610	737
A-BW	in	14.5	15.0	18.0	24.0	29.0
	mm	368	381	457	610	737
B	in	22.6	26.0	30.6	39.6	60.1
	mm	574	660	777	1006	1527
C	in	12.0	16.0	20.0	24.0	24.0
	mm	305	406	508	610	610
RF Wt.	lbs	198	335	440	1675	2090
	kg	90	152	200	761	950
BW Wt.	lbs	176	297	376	1144	1634
	kg	80	135	171	520	743

Note: Dimensions: Inches/Millimeters - Weights: Pounds/Kilograms. Larger sizes available on request. Dimensions are subject to change without notice.

Cast Steel Bolted Bonnet Globes

Styles: CB2, CB3, & CB4/2

Class: 1500 - Sizes: 2" thru 6"

Pressure Class Range: 150 thru 1500

Design and Manufacturing Standards

Valve Design: ASME B16.34/API 600

Flange Dimensions: ASME B16.5, B16.47 (Series A)

Face-to-Face Dimensions: ASME B16.10

Tested in Accordance with: API 598

Recommended Spare Parts*

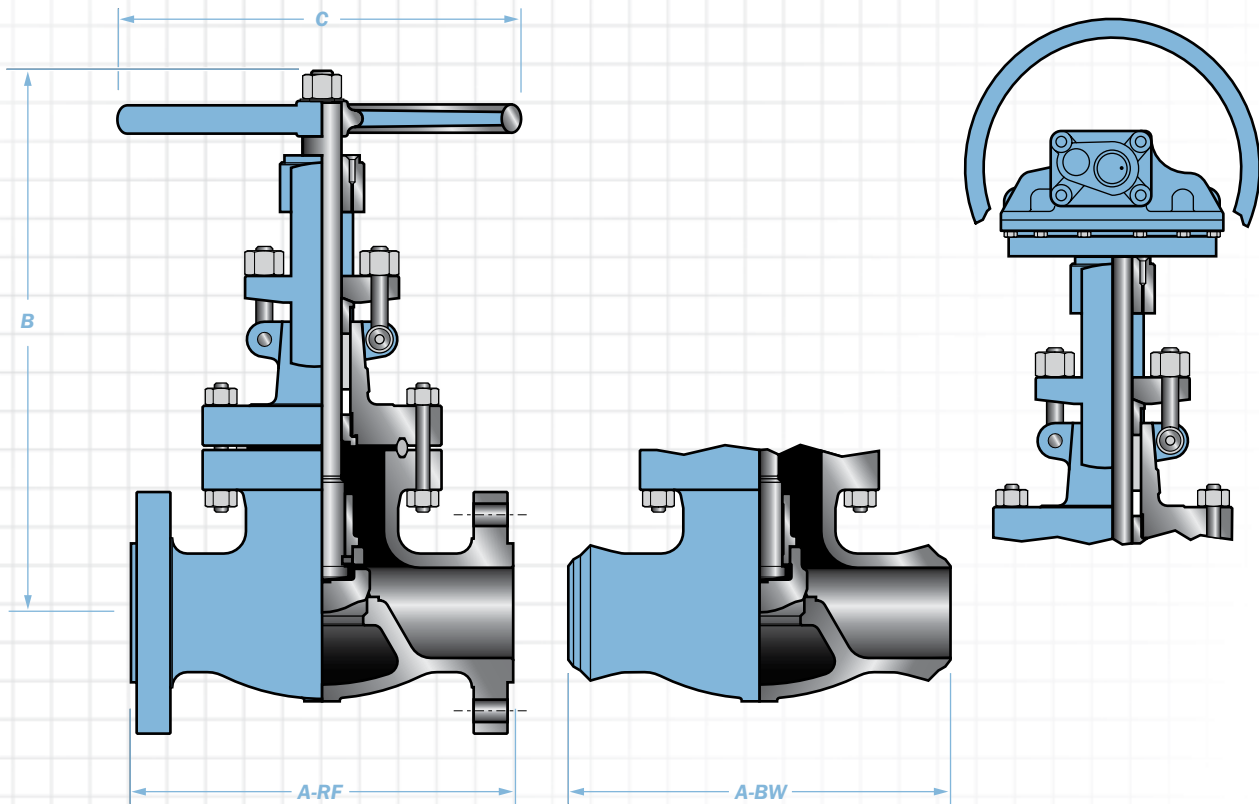

Typical Bill of Materials (See page 5 for available materials.)

Component	CB2	CB3	CB4/2	Component	CB2	CB3	CB4/2
Body	ASTM A216-WCB/HF			Gland Bolt Pins	ASTM A36		
Disc 2" thru 4"	ASTM A276-410	ASTM A216-WCB/ HF	ASTM A276-316	Gland Nuts	ASTM A194-2H	ASTM A194-2HM	
Disc 5" and larger	ASTM A216-WCB/ 13% Chrome		ASTM A216- WCB/316	Gland Bolts	ASTM A307-B		ASTM A193-B7M
Stem	ASTM A276-410		ASTM A276-316	Seat Ring	Integral		
Bonnet	ASTM A216-WCB			Split Ring	ASTM A276-410		
*Bonnet Gasket	Soft Steel Ring Joint			Nameplate	ASTM A666-304		
Bonnet Nuts	ASTM A194-2H	ASTM A194-2HM		Nameplate Rivets	Commercial		
Bonnet Studs	ASTM 193-B7	ASTM A193-B7M		Disc Nut	ASTM A276-410	ASTM A276-316	
Back Seat Bushing	ASTM A276-410	ASTM A276-316		Stem Nut	ASTM A439-D2		
*Packing	Graphite W/Braided Carbon Fiber End Rings			Handwheel Washer	ASTM A36		
Gland	ASTM A276-410	ASTM A276-316		Handwheel Nut	ASTM A36		
Gland Flange	ASTM A276-WCB			Handwheel	ASTM A536 (65-45-12)		
				Spacer Ring	ASTM A276-410		

Class 1500

Size	nps	2	3	4	6
A-RF	in	14.5	18.5	21.5	27.75
	mm	368	470	546	705
A-BW	in	14.5	18.5	21.5	27.75
	mm	368	470	546	705
B	in	19.6	25.6	30.8	36.5
	mm	498	650	782	927
C	in	9.8	17.7	19.7	25.2
	mm	249	450	500	640
RF Wt.	lbs	209	551	959	1191
	kg	95	250	436	541
BW Wt.	lbs	143	460	830	996
	kg	65	209	377	453

Note: Dimensions: Inches/Millimeters - Weights: Pounds/Kilograms. Larger sizes available on request. Dimensions are subject to change without notice.



We offer daily tours.

How many others can say that?

We're not just smoke and mirrors like some, you can actually come see how we make them!

Newmans manufactures the Newco, OIC, and Cooper lines of products in a full range of sizes, classes, and materials. Newmans' manufacturing practice is designed to control our foundries and processing facilities to ensure a quality product, on-time, at a competitive price.

Newmans' production facilities are certified to the requirements of the ISO 9001:2000 Standard and comply with API, ASTM, and ASME industry standards. All Newmans' products are manufactured, inspected, and tested in accordance with the most rigid quality standards as well as any specific customer requirements.

Allow us to show you why Newmans is "The Reliable Source" for all your valve needs.

- **Engineered Solutions**
- **Complete Alloy Coverage**
- **Ready to Ship Inventories**
- **Competitive Factory Lead Times**
- **Sizes 1/2" to 60" Classes 125 to 4500**
- **Industry Approved Products**



Toll Free: 800.231.3505
www.NewmansValve.com



Newco[®]

Cast Steel Bolted Bonnet Angle Valves

Sizes: 2" thru 12" • Pressure Class: 150 thru 600



Typical Newco Cast Steel Bolted Bonnet Angle Valve Expanded View

1. Body: Newco cast steel bodies provide low resistance flow and optimum strength and performance.

2. Bonnet: Newco bonnet assemblies are built to the same standards as the bodies.

3. Back Seat Bushing: The back seat, when engaged with the stem head, provides a stable shutoff to the stuffing box which isolates the packing from flow exposure.

4. Stem: The stem inserts vertically into the disc.

5. Lock Groove: The lock groove receives the split lock ring which allows the disc nut to lift the disc during cycling.

6. Split Ring: The split ring allows the disc nut to lift the disc during cycling.

7. Disc: Newmans disc is machined to the tightest tolerances to ensure trouble free shutoff and cycling.

8. Disc Nut: The disc nut, in conjunction with the split lock ring, secures the disc to the stem.

9. Gland: Compresses the packing to create a stem seal above the back seat, between the bonnet and stem.

10. Gland Flange: Applies pressure to the gland for accurate packing compression.

11. & 12. Gland Bolts & Nuts: The gland bolt and nut allows for easy adjustments for packing compression.

13. Gland Bolt Pin: The gland bolt pin secures the gland bolts to the yoke & bonnet.

14. Packing: The packing creates a seal above the back seat, between the bonnet and stem.

15. Stuffing Box: The stuffing box contains the packing.

16. Stem Nut: The stem nut provides a precision guide for proper stem alignment.

17. Handwheel: The handwheel cycles the valve.

18. Handwheel Nut: The handwheel nut secures the handwheel to the bonnet assembly.

19. Handwheel Washer: The washer helps to prevent loosening or distributes pressure evenly.

20. Bonnet Gasket: The bonnet gasket creates a leakproof seal between the bonnet and body.

21. & 22. Bonnet Studs & Nuts: The bonnet studs and nuts secure the bonnet to the body.

23. Seat Ring: To ensure a stable shutoff, the seat rings is aligned and seal-welded into the valve, then precision ground for optimal seating.

24. Disc Guide: The disc guides provide a stable track for keeping the disc aligned with the seat during cycling.

25. Spacer Ring: Assists the packing rings in creating a seal above the back seat, between the bonnet and stem.

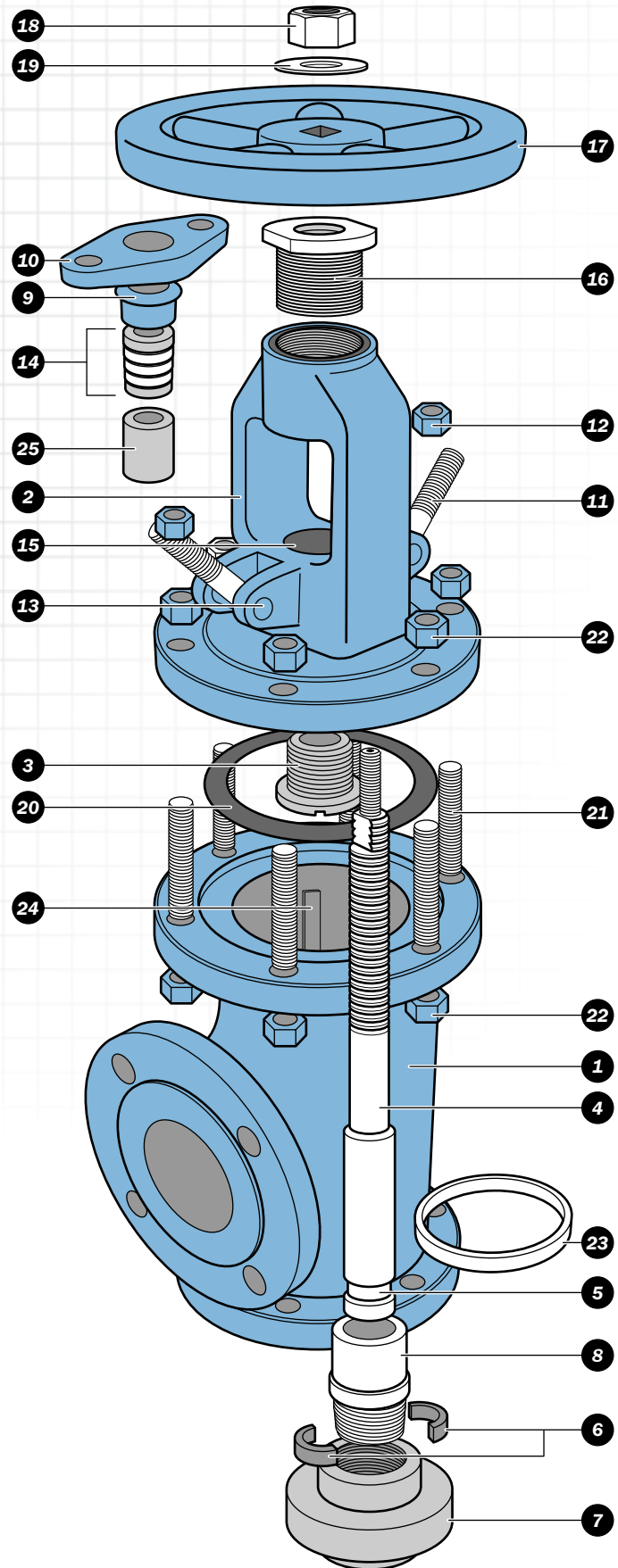

Cast Steel Bolted Bonnet Angles

Styles: CB2, CB3, & CB4/2

Class: 150 - Sizes: 2" thru 12"

Pressure Class Range: 150 thru 600

Design and Manufacturing Standards

Valve Design: ASME B16.34/API 600

Flange Dimensions: ASME B16.5, B16.47 (Series A)

Face-to-Face Dimensions: ASME B16.10

Tested in Accordance with: API 598

Recommended Spare Parts*

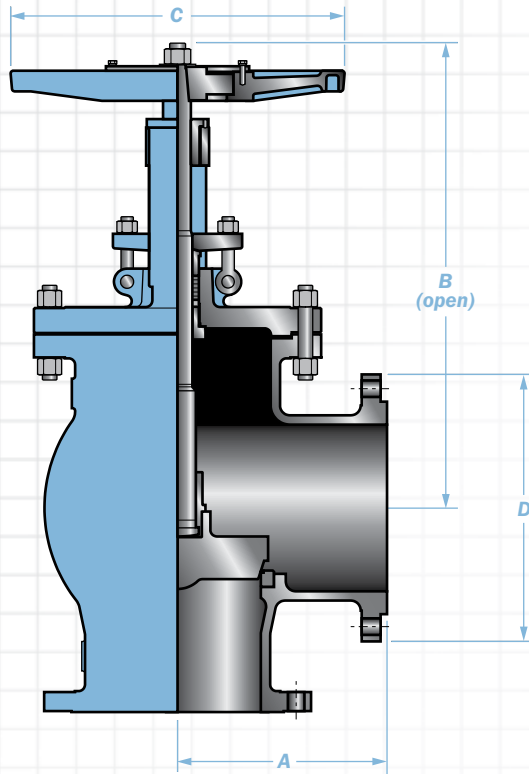

Typical Bill of Materials (See page 5 for available materials.)

Component	CB2	CB3	CB4/2	Component	CB2	CB3	CB4/2
Body	ASTM A216 GR.WCB			Packing	Die Formed Graphite with Braided Graphite End Rings		
Seat Ring	ASTM A105			Gland Bolt Pins	Commercial		
Disc	ASTM A276 - 410			Gland Bolts	ASTM A193 GR.B7		
Disc Nut	ASTM A276 - 410			Gland	ASTM A276 - 410		
Stem	ASTM A182 F6a			Gland Flange	ASTM A216 GR.WCB		
*Bonnet Gasket	Spiral Wound 316 Stainless Steel/Graphite			Gland Bolt Nuts	ASTM A194 GR.2H		
Bonnet	ASTM A216 GR.WCB			Stem Nut	ASTM A439 GR.D-2		
Bonnet Studs	ASTM A193 GR.B7			Split Ring			
Bonnet Nuts	ASTM A194 GR.2H			Handwheel	ASTM A539 Type 60-40-18		
Back Seat Bushing	ASTM A276 - 410			Handwheel Nut	Commercial		
Spacer Ring	ASTM A276 - 410			Handwheel	Commercial		

Class 150

Size	nps dn	2	3	4	6	8	10	12
		50	75	100	150	200	250	300
A	in	4.0	4.75	5.75	8.0	9.75	12.25	13.75
	mm	107	121	146	203	248	311	349
B	in	15.2	16.9	20.4	21.8	27.4	31	37.8
	mm	386	429	518	554	696	787	960
C	in	8	10	12	15	18	22	24
	mm	203	254	305	381	457	559	610
D	in	6	7.5	9	11	13.5	16	19
	mm	152	191	229	279	343	406	483
RF Wt.	lbs	57	84	141	234	399	611	794
	kg	125	185	310	515	878	1344	1747

Note: Dimensions: Inches/Millimeters - Weights: Pounds/Kilograms. Larger sizes available on request. Dimensions are subject to change without notice.

Cast Steel Bolted Bonnet Angles

Styles: CB2, CB3, & CB4/2

Class: 300 - Sizes: 2" thru 12"

Pressure Class Range: 150 thru 600

Design and Manufacturing Standards

Valve Design: ASME B16.34/API 600

Flange Dimensions: ASME B16.5, B16.47 (Series A)

Face-to-Face Dimensions: ASME B16.10

Tested in Accordance with: API 598

Recommended Spare Parts*

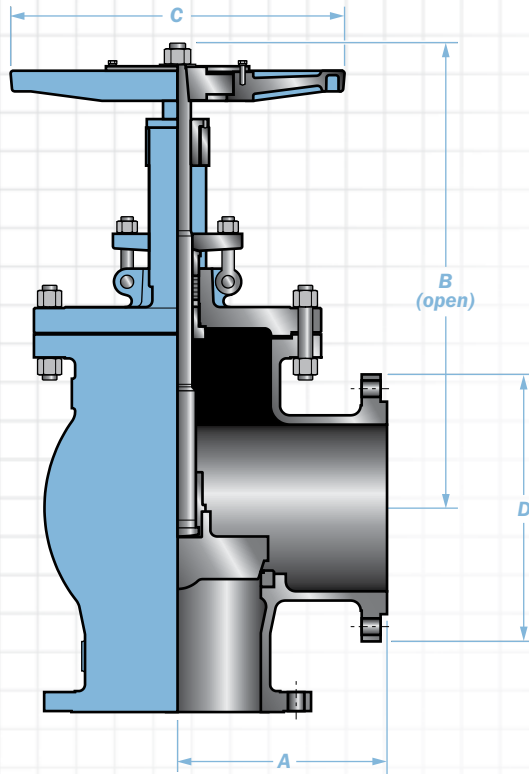

Typical Bill of Materials (See page 5 for available materials.)

Component	CB2	CB3	CB4/2	Component	CB2	CB3	CB4/2
Body	ASTM A216 GR.WCB			Packing	Die Formed Graphite with Braided Graphite End Rings		
Seat Ring	ASTM A105			Gland Bolt Pins	Commercial		
Disc	ASTM A276 - 410			Gland Bolts	ASTM A193 GR.B7		
Disc Nut	ASTM A276 - 410			Gland	ASTM A276 - 410		
Stem	ASTM A182 F6a			Gland Flange	ASTM A216 GR.WCB		
*Bonnet Gasket	Spiral Wound 316 Stainless Steel/Graphite			Gland Bolt Nuts	ASTM A194 GR.2H		
Bonnet	ASTM A216 GR.WCB			Stem Nut	ASTM A439 GR.D-2		
Bonnet Studs	ASTM A193 GR.B7			Split Ring			
Bonnet Nuts	ASTM A194 GR.2H			Handwheel	ASTM A539 Type 60-40-18		
Back Seat Bushing	ASTM A276 - 410			Handwheel Nut	Commercial		
Spacer Ring	ASTM A276 - 410			Handwheel	Commercial		

Class 300

Size	nps dn	2	3	4	6	8	10	12
		50	75	100	150	200	250	300
A	in	5.25	6.25	7	8.75	11	12.25	14
	mm	133	159	178	222	279	311	356
B	in	15	16.9	21.7	28	30.7	37.5	41.6
	mm	381	429	551	711	780	953	1049
C	in	10	12	14	17	24	24	27
	mm	254	305	356	432	610	610	686
D	in	6.5	8.25	10	12.5	15	17.5	20.5
	mm	165	210	254	318	381	445	521
RF Wt.	lbs	68	108	198	392	560	934	1288
	kg	150	238	436	862	1232	2055	2837

Note: Dimensions: Inches/Millimeters - Weights: Pounds/Kilograms. Larger sizes available on request. Dimensions are subject to change without notice.

Cast Steel Bolted Bonnet Angles

Styles: CB2, CB3, & CB4/2

Class: 600 - Sizes: 2" thru 8"

Pressure Class Range: 150 thru 600

Design and Manufacturing Standards

Valve Design: ASME B16.34/API 600

Flange Dimensions: ASME B16.5, B16.47 (Series A)

Face-to-Face Dimensions: ASME B16.10

Tested in Accordance with: API 598

Recommended Spare Parts*

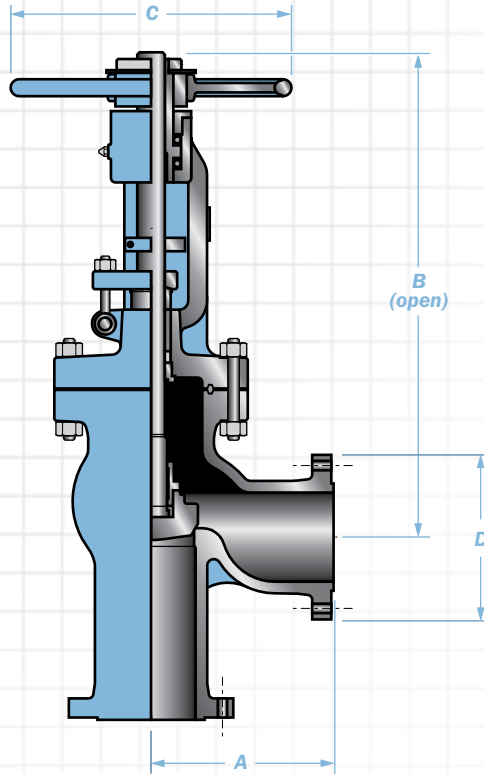

Typical Bill of Materials (See page 5 for available materials.)

Component	CB2	CB3	CB4/2	Component	CB2	CB3	CB4/2
Body		ASTM A216 GR.WCB		Packing	Die Formed Graphite with Braided Graphite End Rings		
Seat Ring		ASTM A105		Gland Bolt Pins	Commercial		
Disc		ASTM A276 - 410		Gland Bolts	ASTM A193 GR.B7		
Disc Nut		ASTM A276 - 410		Gland	ASTM A276 - 410		
Stem		ASTM A182 F6a		Gland Flange	ASTM A216 GR.WCB		
*Bonnet Gasket		Soft Steel Ring Joint		Gland Bolt Nuts	ASTM A194 GR.2H		
Bonnet		ASTM A216 GR.WCB		Stem Nut	ASTM A439 GR.D-2		
Bonnet Studs		ASTM A193 GR.B7		Split Ring			
Bonnet Nuts		ASTM A194 GR.2H		Handwheel	ASTM A539 Type 60-40-18		
Back Seat Bushing		ASTM A276 - 410		Handwheel Nut	Commercial		
Spacer Ring		ASTM A276 - 410		Handwheel	Commercial		

Class 600

Size	nps dn	2	2.5	3	4	6	8
		50	75	100	150	200	250
A	in	5.75	6.5	7.0	8.5	11.0	13.0
	mm	146	165	178	216	279	330
B	in	18.9	20.9	19.8	22.2	28.2	38.5
	mm	480	531	503	564	716	978
C	in	8.8	9.8	11.0	14.0	17.7	24.8
	mm	224	249	279	356	450	630
D	in	6.5	7.5	8.3	9.0	14.0	16.5
	mm	165	191	211	229	356	419
RF	lbs	79	110	141	256	640	961
Wt.	kg	36	50	64	116	291	437

Note: Dimensions: Inches/Millimeters - Weights: Pounds/Kilograms. Larger sizes available on request. Dimensions are subject to change without notice.

Newmans fine assortment of Newco and OIC forged valves is guaranteed to satisfy the most discriminating of tastes.

A complete line of forged steel and forged stainless steel gates, globes, and checks in sizes: 1/4" thru 2" & classes: 150 thru 4500



 **Newmans**
The Reliable Source

Corporate Office: 1300 Gazin St. - Houston, TX 77020
Toll Free: 1.800.231.3505 • www.NewmansValve.com

Newco®

Cast Steel Bolted Cover Swing Check Valves

Manufactured by Newmans™

Sizes: 2" thru 24" • Pressure Class: 150 thru 1500



Typical Newco Cast Steel Bolted Cover Swing Check Valve Expanded View

Note: Classes 150 & 300 uses external hinge pin

- 1. Body:** Newco cast steel bodies provide low resistance flow and optimum strength and performance.
- 2. Cover:** The cover allows access to internal components.
- 3. Cover Gasket:** The cover gasket creates a leakproof seal between the bonnet and body.
- 4. Seat Ring:** To ensure a stable shutoff, the seat ring is aligned and seal-welded into the valve, then precision ground for optimal seating.
- 5. Disc:** The disc allows uni-directional flow and restricts back flow with trouble free shutoff.
- 6. Swing Arm:** The swing arm allows the disc to open and close.
- 7. & 8. Disc Nut & Pin:** The disc nut and pin secures the disc to the swing arm.
- 9. Hinge Pin:** The hinge pin provides a stable mechanism for the swing arm to operate.
- 10. Plug:** The plug secures the arm pin inside the valve.
- 11. Plug Gasket:** The plug gasket creates a leak-proof seal between the plug and body.
- 12. & 13. Cover Studs & Nuts:** The cover studs and nuts secure the bonnet to the body.
- 14. Eyebolt:** The eyebolt is use to aid in lifting the valve.

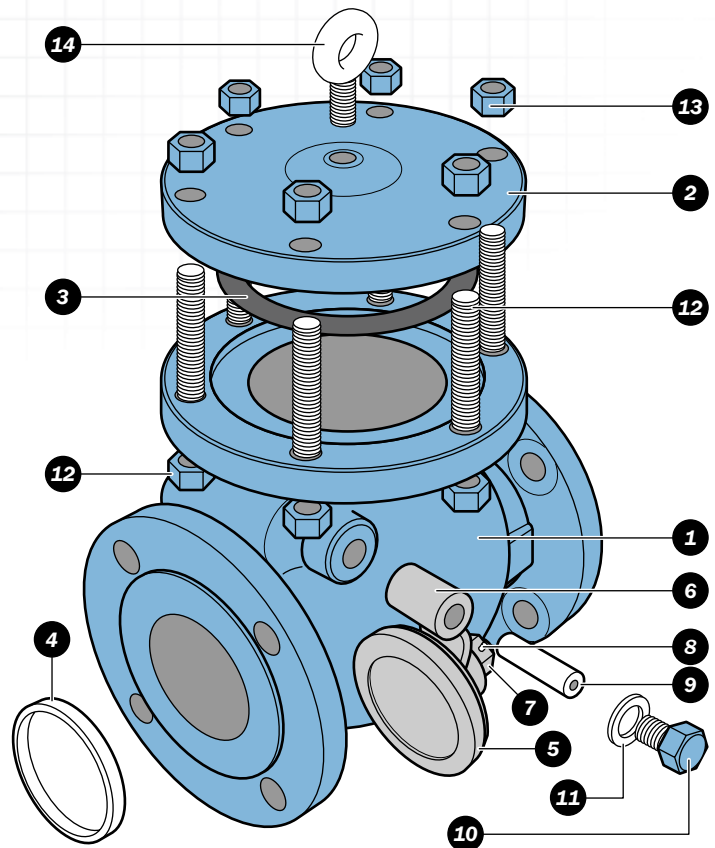

Cast Steel Bolted Cover Swing Checks

Styles: CB2, CB3, & CB4/2

Class: 150 - Sizes: 2" thru 24"

Pressure Class Range: 150 thru 1500

Design and Manufacturing Standards

Valve Design: ASME B16.34/API 600

Flange Dimensions: ASME B16.5, B16.47 (Series A)

Face-to-Face Dimensions: ASME B16.10

Tested in Accordance with: API 598

Recommended Spare Parts*

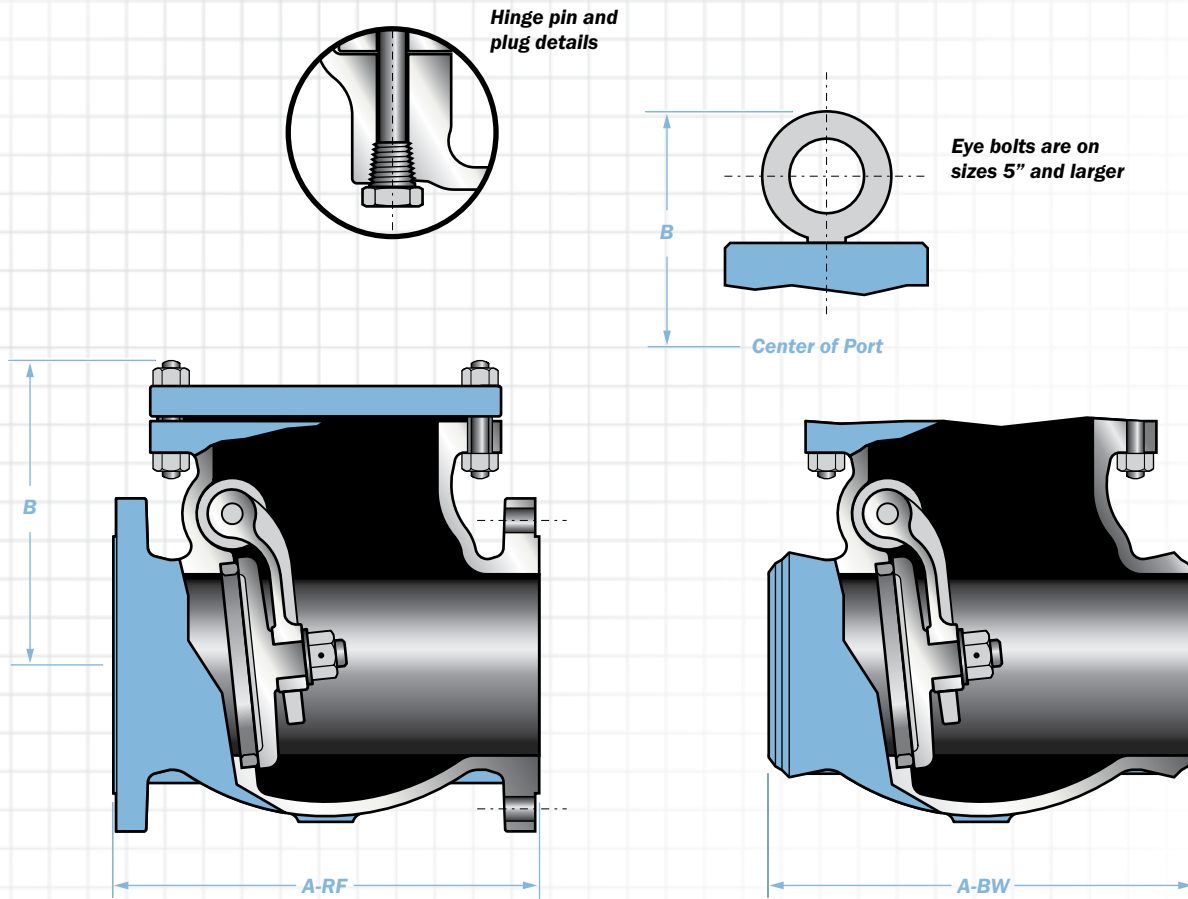

Typical Bill of Materials (See page 5 for available materials.)

Component	CB2	CB3	CB4/2	Component	CB2	CB3	CB4/2
Body	ASTM A216-WCB			Name Plate	304 Stainless Steel		
Cover	ASTM A105N			Plug Gasket	Stainless Steel		
Disc 2" thru 5"	ASTM A182-F6a	ASTM A182-F6a /HF	ASTM A182-F316/HF	Cover Bolt	ASTM A193-B7	ASTM A193-B7M	
Disc 6" and larger	ASTM A216-WCB /13% Chrome	ASTM A216-WCB/HF	ASTM A216-WCB/316 Faced	Cover Nut	AISI 1020		
Swing Arm	ASTM A216-WCB			Plug	ASTM A276-410	ASTM A276-316	
Seat Ring	ASTM A105			Disc Pin	ASTM A276-316		
*Cover Gasket	Spiral Wound 316 Stainless Steel/Graphite			Disc Nut	A194-8		
Hinge Pin	ASTM A276-410		ASTM A276-316	Eye Bolt 5" thru 24"	Carbon Steel		

Class 150

Size	nps	2	2.5	3	4	5	6	8	10	12	14	16	18	20	24
A-RF	in	8.0	8.5	9.5	11.5	13.0	14.0	19.5	24.5	27.5	31.0	34.0	38.5	38.5	51.0
	mm	203	216	241	292	330	356	495	622	699	787	864	978	978	1295
A-BW	in	8.0	8.5	9.5	11.5	13.0	14.0	19.5	24.5	27.5	31.0	34.0	38.5	38.5	51.0
	mm	203	216	241	292	330	356	495	622	699	787	864	978	978	1295
B	in	6.8	7.4	7.7	8.5	12.3	12.8	14.3	17.2	17.9	19.6	21.2	24.2	27.4	30.0
	mm	173	188	196	216	315	325	363	437	455	498	538	615	696	762
RF	lbs	36	51	64	98	135	181	298	463	688	898	1147	1367	1808	2866
Wt.	kg	16	23	29	45	61	398	135	210	313	408	521	621	822	1308
BW	lbs	29	38	49	73	110	146	243	421	591	766	979	1190	1585	2250
	kg	13	17	22	33	50	66	110	191	269	348	445	541	720	1123

Note: Dimensions: Inches/Millimeters - Weights: Pounds/Kilograms. Larger sizes available on request. Dimensions are subject to change without notice.

Cast Steel Bolted Cover Swing Checks

Styles: CB2, CB3, & CB4/2

Class: 300 - Sizes: 2" thru 24"

Pressure Class Range: 150 thru 1500

Design and Manufacturing Standards

Valve Design: ASME B16.34/API 600

Flange Dimensions: ASME B16.5, B16.47 (Series A)

Face-to-Face Dimensions: ASME B16.10

Tested in Accordance with: API 598

Recommended Spare Parts*

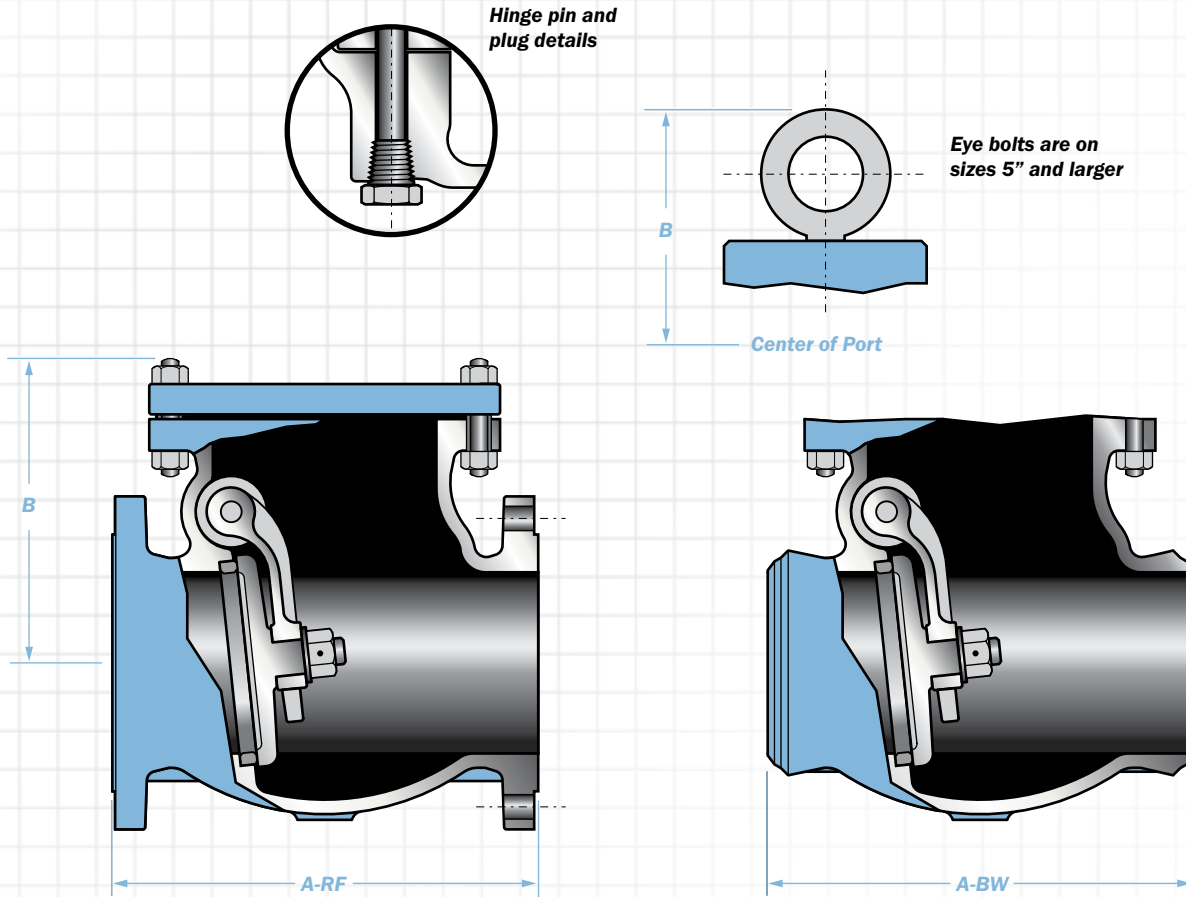

Typical Bill of Materials (See page 5 for available materials.)							
Component	CB2	CB3	CB4/2	Component	CB2	CB3	CB4/2
Body	ASTM A216-WCB			Name Plate	304 Stainless Steel		
Cover	ASTM A105N			Plug Gasket	Stainless Steel		
Disc 2" thru 5"	ASTM A182-F6a	ASTM A182-F6a /HF	ASTM A182-F316/ HF	Cover Bolt	ASTM A193-B7		ASTM A193-B7M
Disc 6" and larger	ASTM A216-WCB /13% Chrome	ASTM A216-WCB/ HF	ASTM A216-WCB/ 316 Faced	Cover Nut	ASTM A276-410		ASTM A276-316
Swing Arm	ASTM A216-WCB			Plug	AISI 1020		
Seat Ring	ASTM A105			Disc Pin	ASTM A276-316		
*Cover Gasket	Spiral Wound 316 Stainless Steel/Graphite			Disc Nut	A194-8		
Hinge Pin	ASTM A276-410		ASTM A276-316	Eye Bolt 5" thru 24"	Carbon Steel		

Class 300															
Size	nps	2	2.5	3	4	5	6	8	10	12	14	16	18	20	24
A-RF	in	10.5	11.5	12.5	14.0	15.75	17.5	21.0	24.5	28.0	33.0	34.0	38.5	40.0	53.0
	mm	267	292	318	356	400	445	533	622	711	838	864	978	1016	1346
A-BW	in	10.5	11.5	12.5	14.0	15.75	17.5	21.0	24.5	28.0	33.0	34.0	38.5	40.0	53.0
	mm	267	292	318	356	400	445	533	622	711	838	864	978	1016	1346
B	in	7.6	8.3	8.9	9.8	13.3	14.0	15.9	18.7	21.9	23.1	25.2	28.6	30.2	33.6
	mm	193	211	226	249	338	356	404	475	556	587	640	726	767	853
RF	lbs	58	86	95	144	232	283	433	694	1003	1345	1720	2271	2888	4718
Wt.	kg	26	39	43	65	105	129	197	315	456	611	782	1032	1313	2145
BW	lbs	44	55	78	103	185	214	341	562	815	1087	1397	1873	2400	3995
	kg	20	25	35	47	84	97	155	255	370	494	635	851	1091	1816

Note: Dimensions: Inches/Millimeters - Weights: Pounds/Kilograms. Larger sizes available on request. Dimensions are subject to change without notice.

Cast Steel Bolted Cover Swing Checks

Styles: CB2, CB3, & CB4/2

Class: 600 - Sizes: 2" thru 14"

Pressure Class Range: 150 thru 1500

Design and Manufacturing Standards

Valve Design: ASME B16.34/API 600

Flange Dimensions: ASME B16.5, B16.47 (Series A)

Face-to-Face Dimensions: ASME B16.10

Tested in Accordance with: API 598

Recommended Spare Parts*

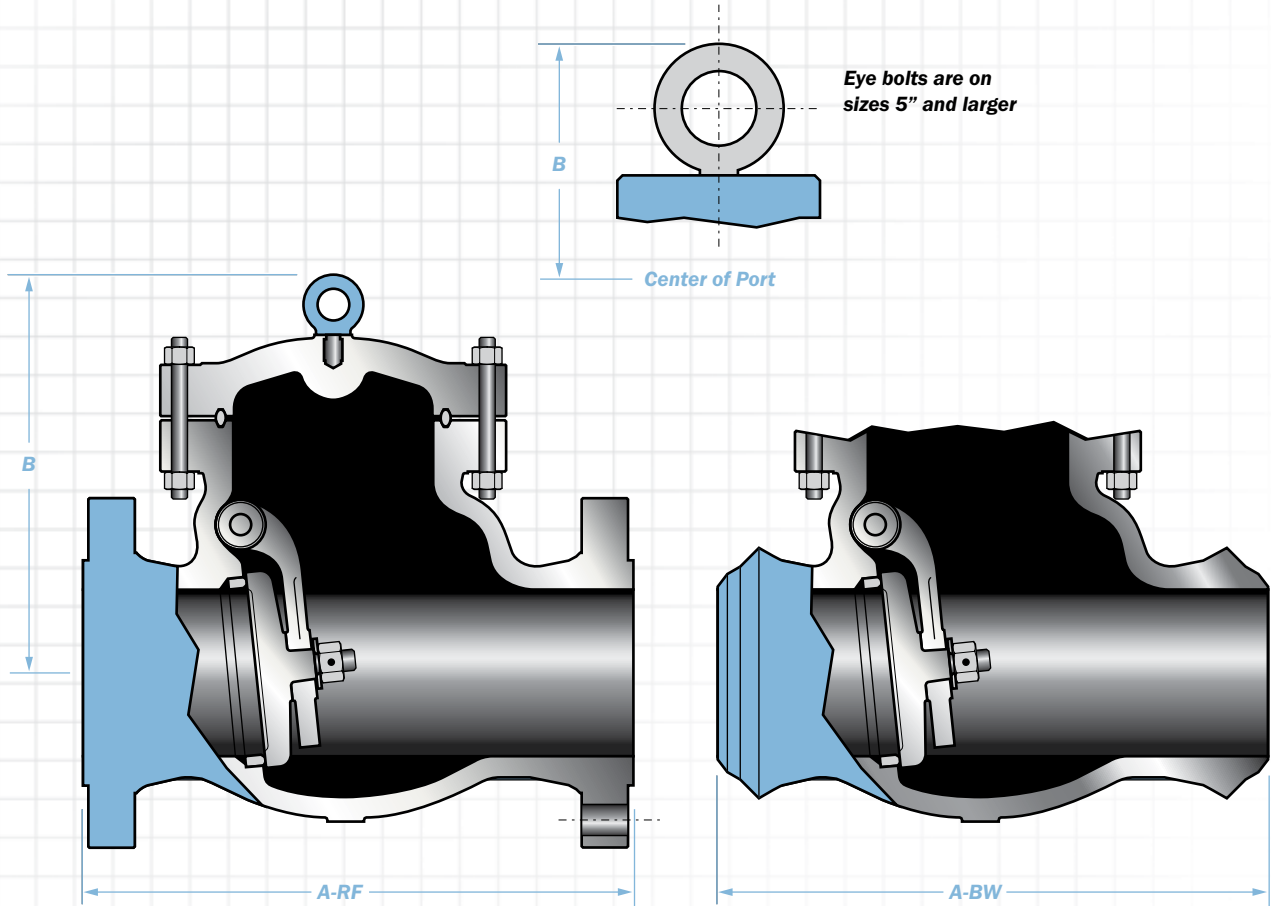

Typical Bill of Materials (See page 5 for available materials.)

Component	CB2	CB3	CB4/2	Component	CB2	CB3	CB4/2
Body	ASTM A216-WCB			Name Plate	304 Stainless Steel		
Cover	ASTM A105N			Washer	Stainless Steel		
Disc 2" thru 5"	ASTM A182-F6a	ASTM A182-F6a /HF	ASTM A182-F316	Cover Bolt	ASTM A193-B7	ASTM A193-B7M	
Disc 6" and larger	ASTM A216-WCB /13% Chrome	ASTM A216-WCB/ HF	ASTM A216-WCB/ 316 Faced	Cover Nut	ASTM A276-410	ASTM A276-316	
Swing Arm	ASTM A216-WCB			Plug	AISI 1020		
Seat Ring	ASTM A105			Pin	ASTM A276-316		
*Cover Gasket	Soft Steel Ring Joint			Hex Nut	A194-8		
Hinge Pin	ASTM A276-410		ASTM A276-316	Eye Bolt 5" thru 24"	Carbon Steel		

Class 600

Size	nps	2	2.5	3	4	5	6	8	10	12	14
A-RF	in	11.5	13.0	14.0	17.0	20.0	22.0	26.0	31.0	33.0	35.0
	mm	292	330	356	432	508	559	660	787	838	889
A-BW	in	11.5	13.0	14.0	17.0	20.0	22.0	26.0	31.0	33.0	35.0
	mm	292	330	356	432	508	559	660	787	838	889
B	in	7.8	8.8	9.7	13.3	15.5	16.8	19.4	22.6	25.4	26.4
	mm	198	224	246	338	394	427	493	574	645	671
RF Wt.	lbs	65	90	115	215	348	481	926	1279	1722	2009
	kg	30	41	52	98	159	219	421	581	783	913
BW Wt.	lbs	51	68	91	161	255	349	762	1021	1411	1650
	kg	23	31	41	73	116	159	346	483	641	750

Note: Dimensions: Inches/Millimeters - Weights: Pounds/Kilograms. Larger sizes available on request. Dimensions are subject to change without notice.

Cast Steel Bolted Cover Swing Checks

Styles: CB2, CB3, & CB4/2

Class: 900 - Sizes: 2" thru 8"

Pressure Class Range: 150 thru 1500

Design and Manufacturing Standards

Valve Design: ASME B16.34/API 600

Flange Dimensions: ASME B16.5, B16.47 (Series A)

Face-to-Face Dimensions: ASME B16.10

Tested in Accordance with: API 598

Recommended Spare Parts*

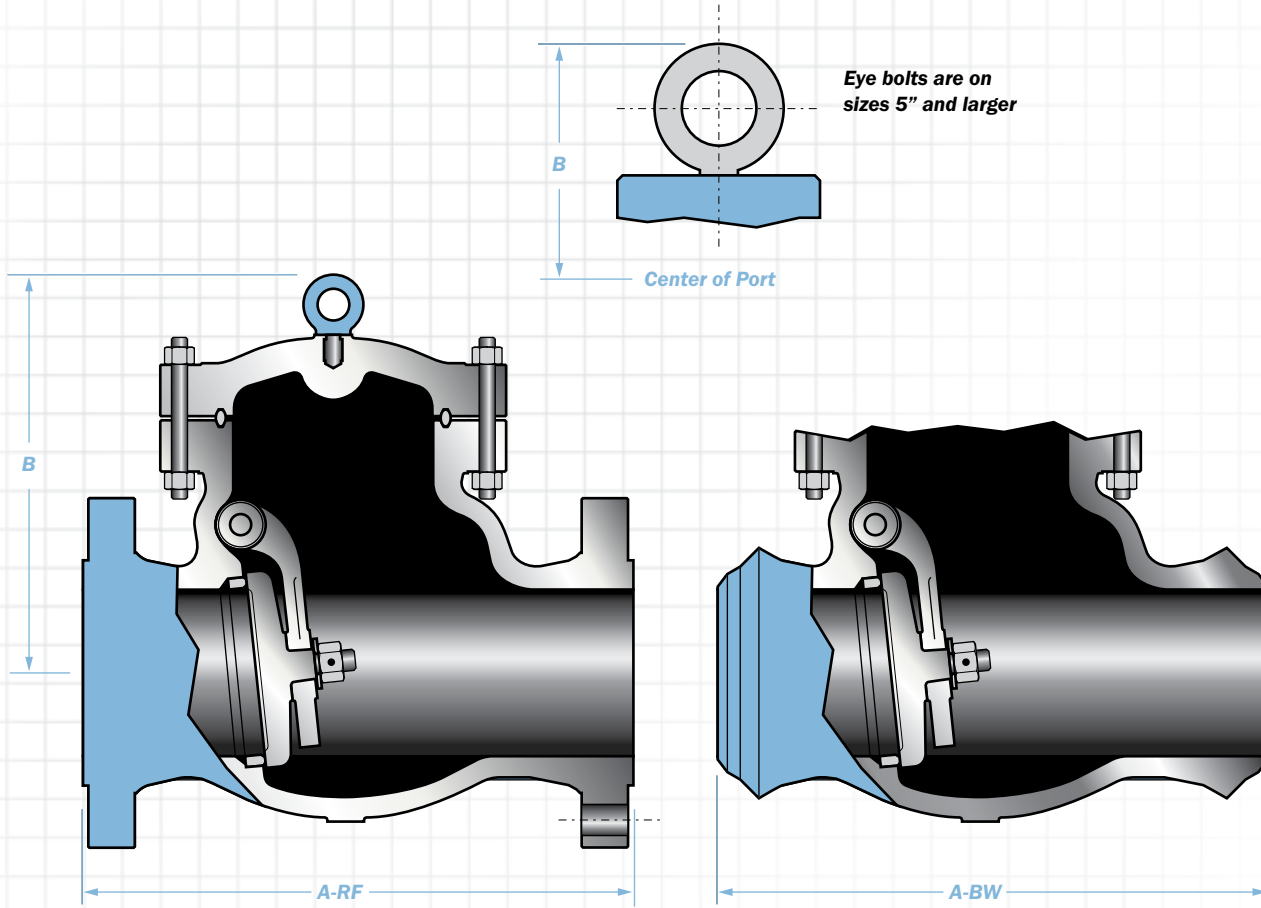

Typical Bill of Materials (See page 5 for available materials.)

Component	CB2	CB3	CB4/2	Component	CB2	CB3	CB4/2
Body	ASTM A216-WCB			Name Plate	304 Stainless Steel		
Cover	ASTM A105N			Washer	Stainless Steel		
Disc 2" thru 5"	ASTM A182-F6a	ASTM A182-F6a /HF	ASTM A182-F316	Cover Bolt	ASTM A193-B7	ASTM A193-B7M	
Disc 6" and larger	ASTM A216-WCB /13% Chrome	ASTM A216-WCB/ HF	ASTM A216-WCB/ 316 Faced	Cover Nut	ASTM A276-410	ASTM A276-316	
Swing Arm	ASTM A216-WCB			Plug	AISI 1020		
Seat Ring	ASTM A105			Pin	ASTM A276-316		
*Cover Gasket	Soft Steel Ring Joint			Hex Nut	A194-8		
Hinge Pin	ASTM A276-410		ASTM A276-316	Eye Bolt 5" thru 24"	Carbon Steel		

Class 900

Size	nps	2	3	4	6	8
	dn	50	75	100	150	200
A-RF	in	14.5	15.0	18.0	24.0	29.0
	mm	368	381	457	610	737
A-BW	in	14.5	15.0	18.0	24.0	29.0
	mm	368	381	457	610	737
B	in	13.1	14.8	14.5	18.8	23.6
	mm	329	329	368	478	599
RF Wt.	lbs	104	184	344	770	1482
	kg	47	84	156	350	674
BW Wt.	lbs	78	138	258	578	1112
	kg	35	63	129	263	505

Note: Dimensions: Inches/Millimeters - Weights: Pounds/Kilograms. Larger sizes available on request. Dimensions are subject to change without notice.

Cast Steel Bolted Cover Swing Checks

Styles: CB2, CB3, & CB4/2

Class: 1500 - Sizes: 2" thru 8"

Pressure Class Range: 150 thru 1500

Design and Manufacturing Standards

Valve Design: ASME B16.34/API 600

Flange Dimensions: ASME B16.5, B16.47 (Series A)

Face-to-Face Dimensions: ASME B16.10

Tested in Accordance with: API 598

Recommended Spare Parts*

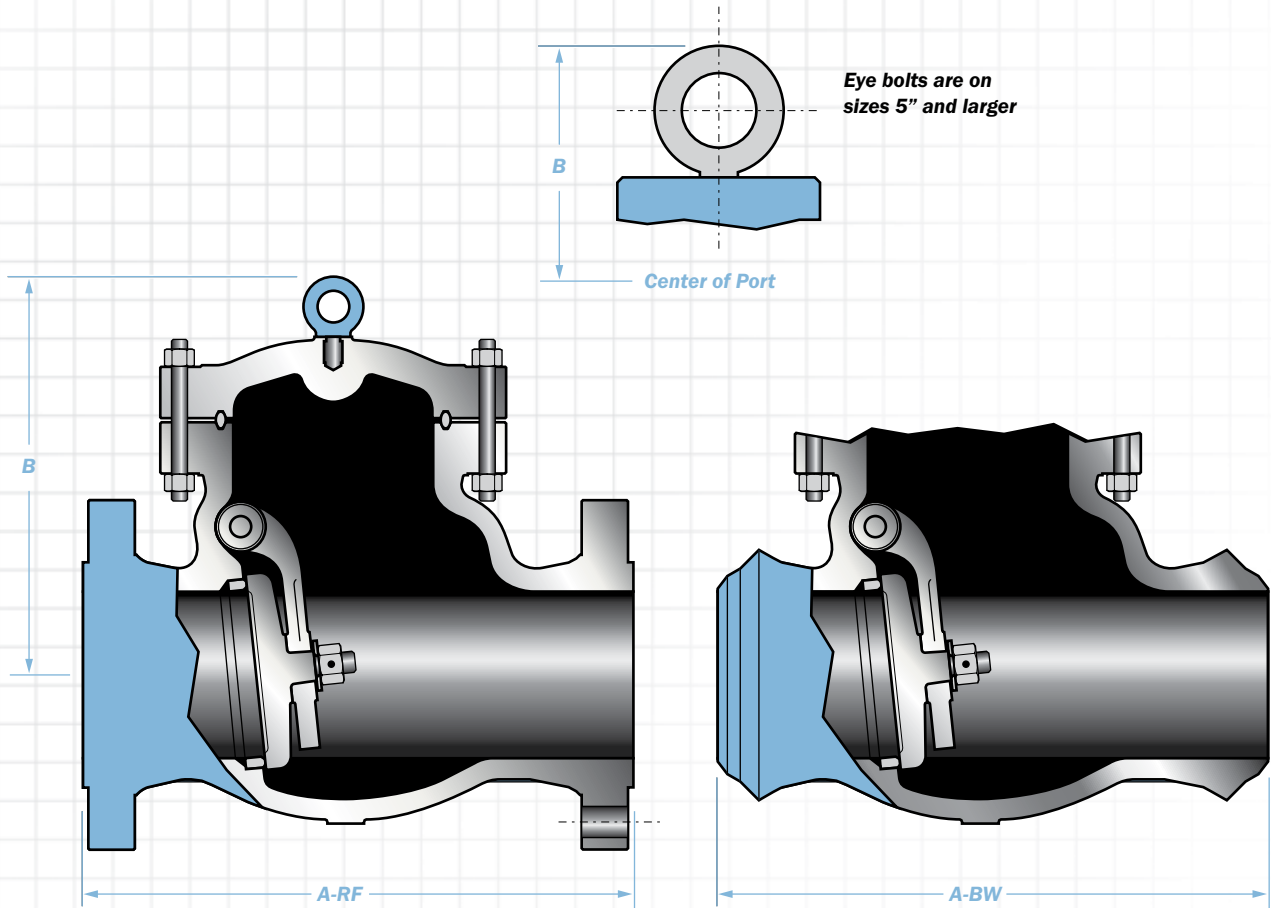

Typical Bill of Materials (See page 5 for available materials.)

Component	CB2	CB3	CB4/2	Component	CB2	CB3	CB4/2
Body	ASTM A216-WCB			Name Plate	304 Stainless Steel		
Cover	ASTM A105N			Washer	Stainless Steel		
Disc 2" thru 5"	ASTM A182-F6a	ASTM A182-F6a /HF	ASTM A182-F316	Cover Bolt	ASTM A193-B7	ASTM A193-B7M	
Disc 6" and larger	ASTM A216-WCB /13% Chrome	ASTM A216-WCB/ HF	ASTM A216-WCB/ 316 Faced	Cover Nut	ASTM A276-410	ASTM A276-316	
Swing Arm	ASTM A216-WCB			Plug	AISI 1020		
Seat Ring	ASTM A105			Pin	ASTM A276-316		
*Cover Gasket	Soft Steel Ring Joint			Hex Nut	A194-8		
Hinge Pin	ASTM A276-410		ASTM A276-316	Eye Bolt 5" thru 24"	Carbon Steel		

Class 1500

Size	nps	2	2.5	3	4	6	8
	dn	50	75	100	150	200	203
A-RF	in	14.5	16.5	18.5	21.5	27.8	32.8
	mm	368	419	470	546	706	833
A-BW	in	14.5	16.5	18.5	21.5	27.8	32.8
	mm	368	419	470	546	706	833
B	in	13.1	13.7	14.8	15.2	19.2	27.0
	mm	333	348	376	386	488	686
RF Wt.	lbs	165	243	284	462	940	1030
	kg	75	110	129	269	427	468
BW Wt.	lbs	153	223	256	425	895	985
	kg	70	101	116	193	407	448

Note: Dimensions: Inches/Millimeters - Weights: Pounds/Kilograms. Larger sizes available on request. Dimensions are subject to change without notice.

POWERful Performers

High quality valves for pressures and temperatures to match.

Newmans manufactures a complete line of Newco, OIC, and Cooper valve products for use in a broad range of applications within Power and Process Industries.

Make Newco Valves your primary source for Severe Service Power applications. We manufacture Cast Pressure Seal and Forged Welded Bonnet Gate, Globe, and Check Valves in sizes through 24" and Pressure Classes through ASME 4500. We offer a full range of materials specific to the Power Industry including A105 (WCB), F9 (C12), F11 (WC6), F22 (WC9), and F91 (C12A).

Our newest member of the Newco family of Products for Power is the QuadroSphere™ Severe Service Ball Valve. Its unique geometry vastly improves Ball and Seat life in high pressure water as well as media containing abrasives by minimizing velocity and protecting the sealing surfaces from erosive effects.

Our in-house Automation Center provides single source expertise for sizing and assembling Motor Operated Valves. Additionally, our Field Service team is available for verification of installation and start up activities.

Newmans' world-wide production facilities are certified to the requirements of the ISO 9001:2000 Standard and compliant to the industry standards of API, ASTM, and ASME. All Newmans' products are manufactured, inspected, and tested in accordance with the most rigid quality standards as well as any specific customer requirements.

Allow us to show why Newmans is "The Reliable Source" for all your valve needs.

- **Engineered Solutions**
- **Complete Alloy Coverage**
- **Ready to Ship Inventories**
- **Competitive Factory Lead Times**
- **Sizes ½" to 60" Classes 125 to 4500**



 **Newmans**
The Reliable Source

Toll Free: 800.231.3505
www.NewmansValve.com



Newco®

Cast Steel Bolted Cover Tilting Disc Check Valves

Manufactured by Newmans™

Sizes: 2" thru 12" • Pressure Class: 150 thru 300 (Pressure Seal 600 thru 2500)



Typical Newco Cast Steel Bolted Cover Tilting Disc Check Valve Expanded View

Note: Classes 600 & larger uses internal hinge pin

- 1. Body:** Newco cast steel bodies provide low resistance flow and optimum strength and performance.
- 2. Cover:** The cover allows access to internal components.
- 3. Cover Gasket:** The cover gasket creates a leak-proof seal between the bonnet and body.
- 4. Seat Ring:** To ensure a stable shutoff, the seat ring is aligned and seal-welded into the valve, then precision ground for optimal seating.
- 5. Disc:** The disc allows uni-directional flow and restricts back flow with trouble free shutoff.
- 6. Plug Gasket:** The plug gasket creates a leak-proof seal between the plug and body.
- 7. Plug:** The disc nut and pin secures the disc to the arm.
- 8. Hinge Pin:** The hinge pin provides a stable mechanism for the disc to operate.
- 9. Hinge Pin Washer:** The hinge pin washer provides accurate disc positioning.
- 10. & 11. Cover Studs & Nuts:** The cover studs and nuts secure the bonnet to the body.
- 12. Eyebolt:** The eyebolt is use to aid in lifting the valve.

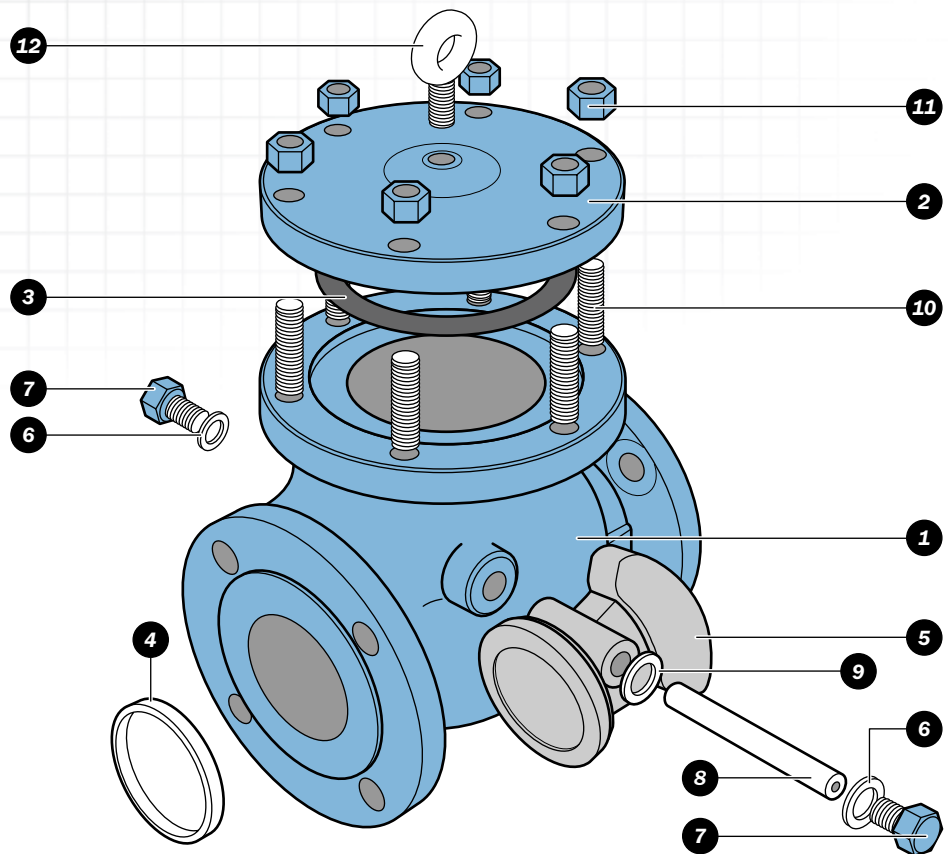

Cast Steel Bolted Cover Tilting Disc Check
Styles: CB2, CB3, & CB4/2
Class: 150 - Sizes: 2.5" thru 12"
Pressure Class Range: 150 thru 300 (See Pressure Seal thru 2500)

Design and Manufacturing Standards

Valve Design: ASME B16.34/API 600

Flange Dimensions: ASME B16.5, B16.47 (Series A)

Face-to-Face Dimensions: ASME B16.10

Tested in Accordance with: API 598

Recommended Spare Parts*

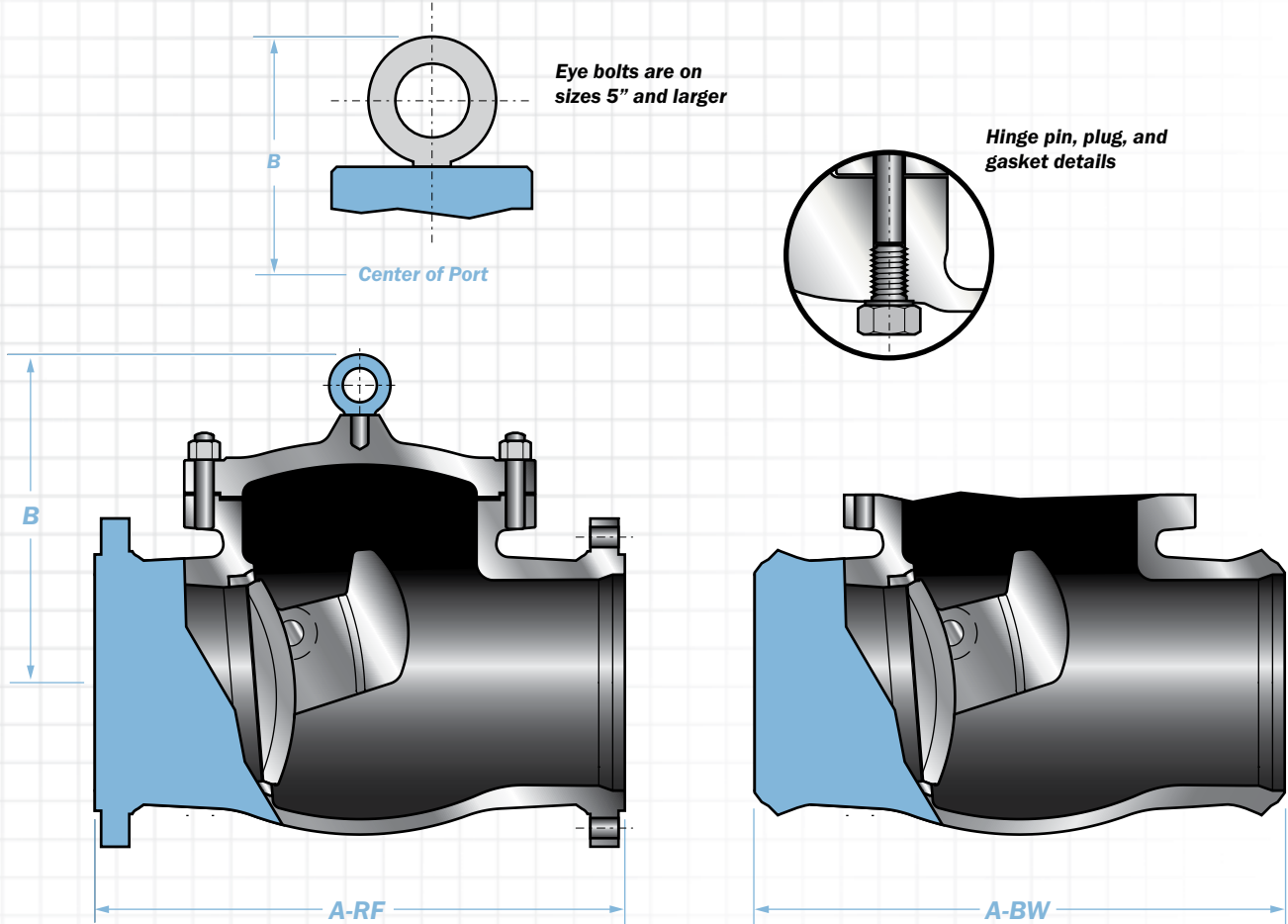

Typical Bill of Materials (See page 5 for available materials.)

Component	CB2	CB3	CB4/2	Component	CB2	CB3	CB4/2
Body	ASTM A216-WCB			Plug Gasket	304 Stainless Steel/Graphite		
Cover	ASTM A105/A216-WCB			Name Plate	304 Stainless Steel		
Disc	ASTM A216-WCB			Cover Bolts	ASTM A193-B7		
Seat Ring	ASTM A283-D/A216-WCB			Cover Nuts	ASTM A194-2H	ASTM A194-2HM	
*Cover Gasket	Spiral Wound 304 Stainless Steel/Graphite			Plug	ASTM A105		
Hinge Pin	ASTM A276-410			Eye Bolt 5" and larger	ASTM A108-1020		
Hinge Pin Washer	ASTM A479-410						

Class 150

Size	nps	2.5	3	4	6	8	10	12
	dn	65	75	100	150	200	250	300
A-RF	in	8.5	9.5	11.5	14.0	19.5	24.5	27.5
	mm	216	241	292	356	495	622	699
A-BW	in	8.5	9.5	11.5	14.0	19.5	24.5	27.5
	mm	216	241	292	356	495	622	699
B	in	8.27	7.5	7.3	9.0	13.8	15.4	16.1
	mm	210	190	185	230	350	390	410
RF	lbs	42	68	92	174	302	477	655
Wt.	kg	92	150	202	383	664	1049	1441
BW	lbs	30	50	78	136	244	376	464
Wt.	kg	66	110	172	299	537	827	1021

Note: Dimensions: Inches/Millimeters - Weights: Pounds/Kilograms. Larger sizes available on request. Dimensions are subject to change without notice.

Cast Steel Bolted Cover Tilting Disc Check

Styles: CB2, CB3, & CB4/2

Class: 300 - Sizes: 3" thru 12"

Pressure Class Range: 150 thru 300 (See Pressure Seal thru 2500)

Design and Manufacturing Standards

Valve Design: ASME B16.34/API 600

Flange Dimensions: ASME B16.5, B16.47 (Series A)

Face-to-Face Dimensions: ASME B16.10

Tested in Accordance with: API 598

Recommended Spare Parts*

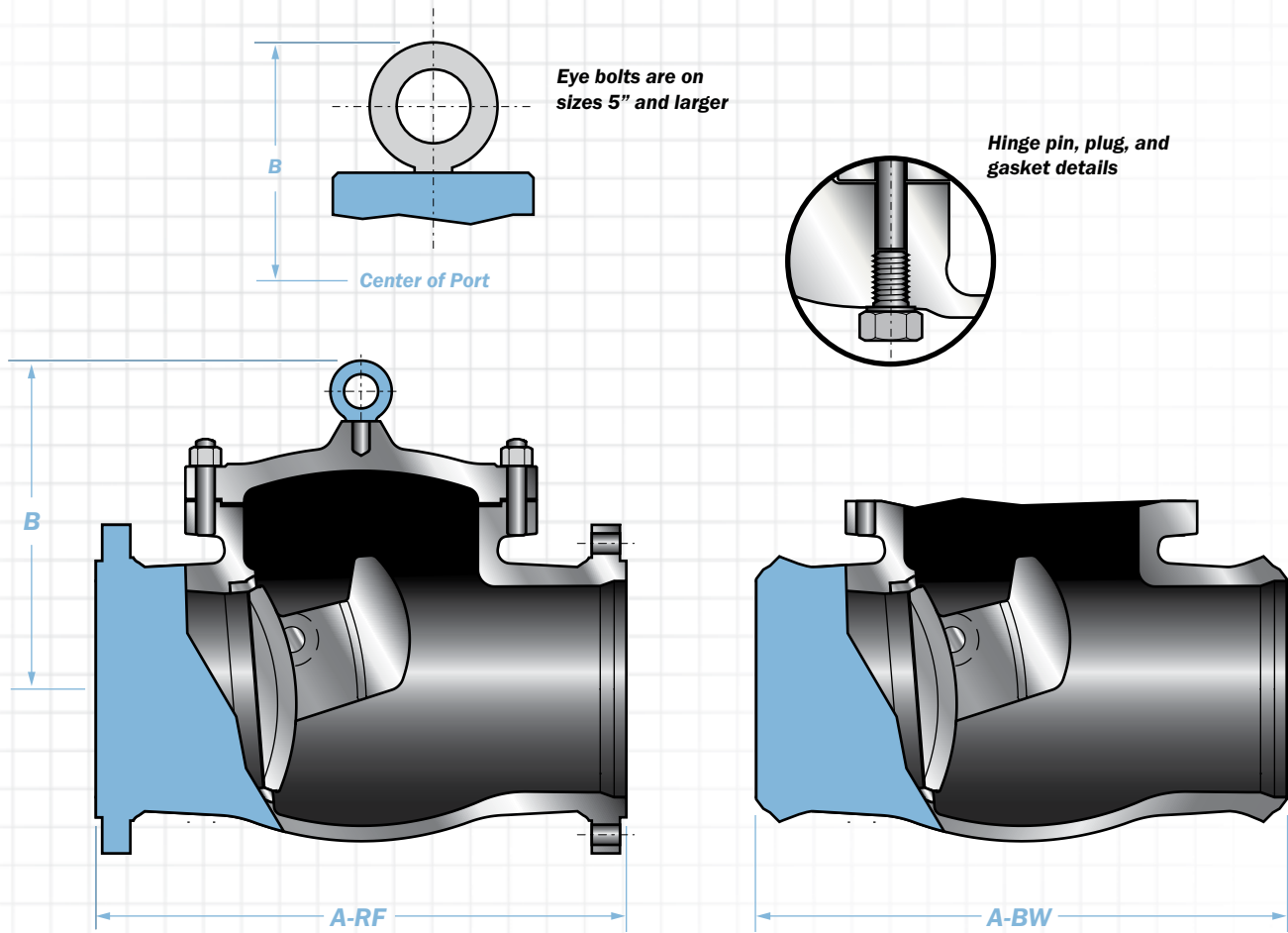

Typical Bill of Materials (See page 5 for available materials.)

Component	CB2	CB3	CB4/2	Component	CB2	CB3	CB4/2
Body	ASTM A216-WCB			Plug Gasket	304 Stainless Steel/Graphite		
Cover	ASTM A105/A216-WCB			Name Plate	304 Stainless Steel		
Disc	ASTM A216-WCB			Cover Bolts	ASTM A193-B7		
Seat Ring	ASTM A283-D/A216-WCB			Cover Nuts	ASTM A194-2H	ASTM A194-2HM	
*Cover Gasket	Spiral Wound 304 Stainless Steel/Graphite			Plug	ASTM A105		
Hinge Pin	ASTM A276-410			Eye Bolt 5" and larger	ASTM A108-1020		
Hinge Pin Washer	ASTM A479-410						

Class 300

Size	nps	3	4	6	8	10	12
	dn	75	100	150	200	250	300
A-RF	in	12.5	14.0	17.5	21.0	24.5	28.0
	mm	318	356	444	533	622	711
A-BW	in	12.5	14.0	17.5	21.0	24.5	28.0
	mm	318	356	444	533	622	711
B	in	6.5	7.3	8.8	13.4	15.2	17.7
	mm	165	185	224	340	385	450
RF Wt.	lbs	82	122	252	386	568	818
	kg	180	268	554	849	1250	1800
BW Wt.	lbs	57	78	168	278	458	690
	kg	125	172	370	612	1008	1518

Note: Dimensions: Inches/Millimeters - Weights: Pounds/Kilograms. Larger sizes available on request. Dimensions are subject to change without notice.

Newco®

Cast Steel Bolted Bonnet Stop Check Valves

Manufactured by Newmans™

Sizes: 2" thru 14" • Pressure Class: 150 thru 1500



Typical Newco Cast Steel Bolted Bonnet Stop Check Valve Expanded View

1. Body: Newco cast steel bodies provide low resistance flow and optimum strength and performance.

2. Bonnet: Newco bonnet assemblies are built to the same standards as the bodies.

3. Back Seat: The back seat, when engaged with the stem head, provides a stable shutoff to the stuffing box which isolates the packing from flow exposure.

4. Stem: The stem inserts vertically into the disc.

5. Disc: Newmans 1-piece vented disc is machined to the tightest tolerances to ensure trouble free shutoff and cycling.

6. Disc Nut: The disc nut serves as a mechanical guide acting on the stem to ensure proper alignment of the disc to the seat.

7. Gland: Compresses the packing to create a stem seal above the back seat, between the bonnet and stem.

8. Gland Flange: Applies pressure to the gland for accurate packing adjustments.

9. & 10. Gland Bolts & Nuts: The gland bolt and nut allows for easy adjustments for packing compression.

11. Gland Bolt Pin: The gland bolt pin secures the gland bolts to the yoke & bonnet.

12. Packing: The packing creates a seal above the back seat, between the bonnet and stem.

13. Stuffing Box: The stuffing box contains the packing.

14. Stem Nut: The stem nut provides a precision guide for proper stem alignment.

15. Handwheel: The handwheel cycles the valve.

16. Handwheel Nut: The handwheel nut secures the handwheel to the bonnet assembly.

17. Handwheel Washer: The washer helps to prevent loosening or distributes pressure evenly.

18. Bonnet Gasket: The bonnet gasket creates a leakproof seal between the bonnet and body.

19. & 20. Bonnet Studs & Nuts: The bonnet studs and nuts secure the bonnet to the body.

21. Seat Ring: To ensure a stable shutoff, the seat ring is aligned and seal-welded into the valve, then precision ground for optimal seating.

22. Disc Guide: The disc guides provide a stable track for keeping the disc aligned with the seat during cycling.

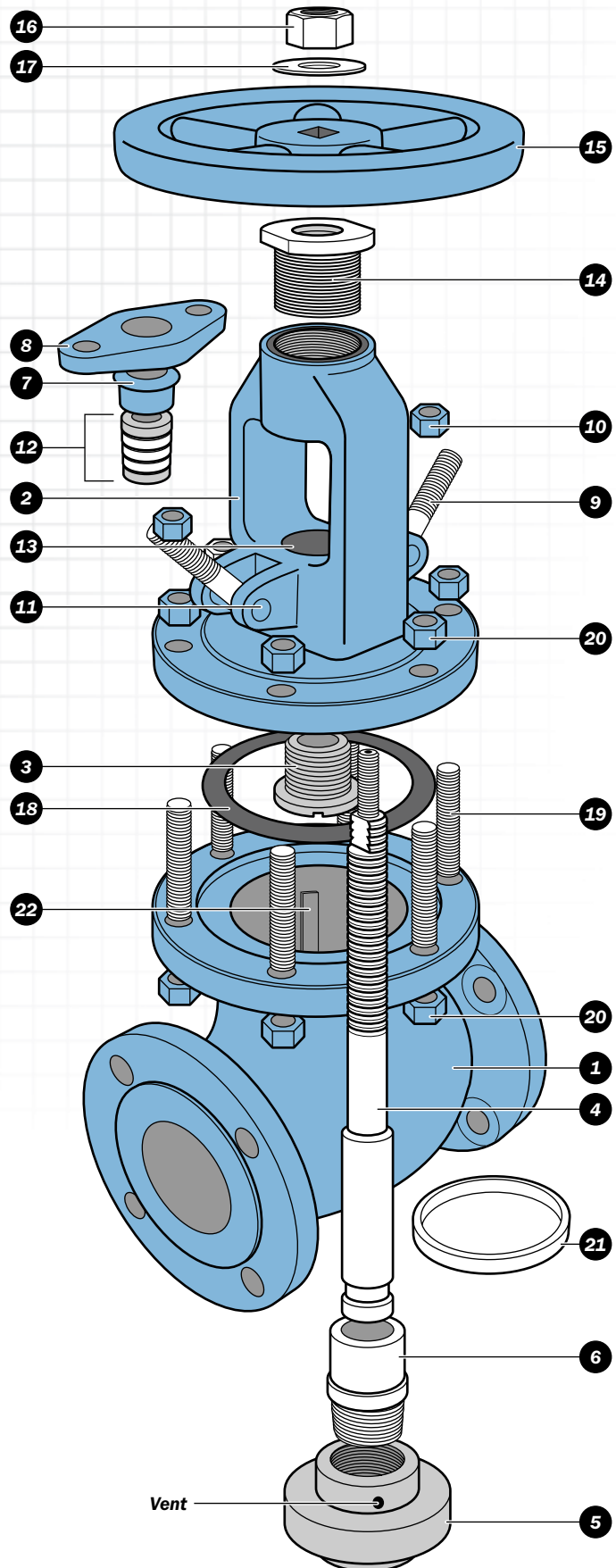

Cast Steel Bolted Cover Stop Checks

Styles: CB2, CB3, & CB4/2

Class: 150 - Sizes: 2" thru 14"

Pressure Class Range: 150 thru 1500

Design and Manufacturing Standards

Valve Design: ASME B16.34/API 600

Flange Dimensions: ASME B16.5, B16.47 (Series A)

Face-to-Face Dimensions: ASME B16.10

Tested in Accordance with: API 598

Recommended Spare Parts*

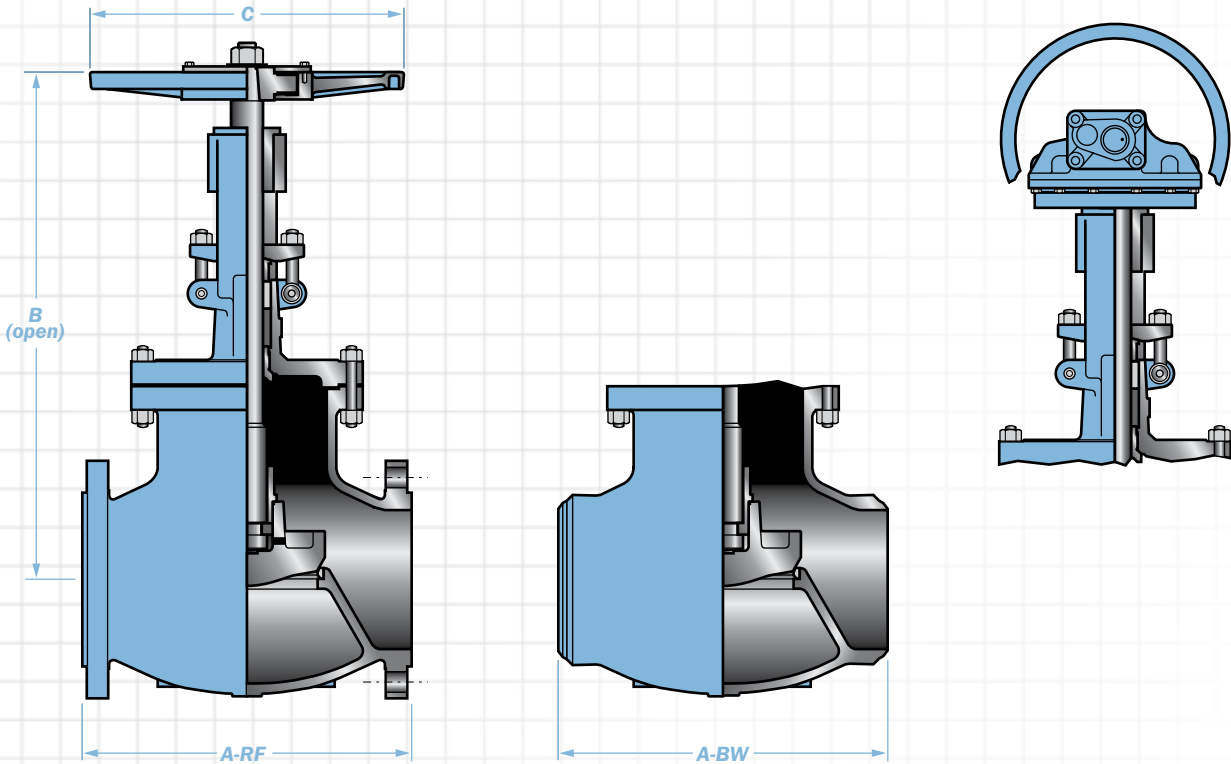

Typical Bill of Materials (See page 5 for available materials.)

Component	CB2	CB3	CB4/2	Component	CB2	CB3	CB4/2
Body	ASTM A216-WCB**			Gland Bolt Pins	ASTM A36		
Disc 2" thru 4"	ASTM A276-410	ASTM A216-WCB/ HF	ASTM A276-316	Gland Nuts	ASTM A194-2H	ASTM A194-2HM	
Disc 5" and larger	ASTM A216-WCB/ 13% Chrome		ASTM A216- WCB/316	Gland Bolts	ASTM A307-B	ASTM A193-B7M	
Stem	ASTM A276-410		ASTM A276-316	Seat Ring	ASTM A105/HF (6" & larger)		
Bonnet	ASTM A216-WCB			Split Ring	N/A		
*Bonnet Gasket	Spiral Wound 316 Stainless Steel/Graphite			Nameplate	ASTM A666-304		
Bonnet Nuts	ASTM A194-2H	ASTM A194-2HM		Nameplate Rivets	Commercial		
Bonnet Studs	ASTM 193-B7	ASTM A193-B7M		Disc Nut	ASTM A276-410	ASTM A276-316	
Back Seat Bushing	ASTM A276-410	ASTM A276-316		Stem Nut	ASTM A439-D2		
*Packing	Graphite W/Braided Carbon Fiber End Rings			Handwheel Washer	ASTM A36		
Gland	ASTM A276-410	ASTM A276-316		Handwheel Nut	ASTM A36		
Gland Flange	ASTM A276-WCB			Handwheel	ASTM A536 (65-45-12)		
				Spacer Ring	N/A		

Class 150

Size	nps	2	2.5	3	4	5	6	8	10	12	14
A-RF	in	8.0	8.5	9.5	11.5	14.0	16.0	19.5	24.5	27.5	31.0
	mm	203	216	241	292	356	406	495	622	699	787
A-BW	in	8.0	8.5	9.5	11.5	14.0	16.0	19.5	24.5	27.5	31.0
	mm	203	216	241	292	356	406	495	622	699	787
B	in	14.9	15.8	16.6	19.9	21.8	22.4	26.5	30.6	34.8	41.4
	mm	378	401	422	505	554	569	673	777	884	1052
C	in	8.0	10.0	10.0	12.0	14.0	16.0	18.0	22.0	24.0	27.0
	mm	203	254	254	305	356	406	457	610	610	610
RF	lbs	51	73	93	137	192	243	419	507	948	1276
Wt.	kg	23	33	42	62	87	110	190	276	476	625
BW	lbs	51	73	93	137	192	243	419	507	948	1276
	kg	23	33	42	62	87	110	190	276	476	625

Note: Dimensions: Inches/Millimeters - Weights: Pounds/Kilograms. Larger sizes available on request. Dimensions are subject to change without notice.

** ASTM A216-WCB/HF for 2" to 4".

Rev: 032307.01

Cast Steel Bolted Cover Stop Checks

Styles: CB2, CB3, & CB4/2

Class: 300 - Sizes: 2" thru 14"

Pressure Class Range: 150 thru 1500

Design and Manufacturing Standards

Valve Design: ASME B16.34/API 600

Flange Dimensions: ASME B16.5, B16.47 (Series A)

Face-to-Face Dimensions: ASME B16.10

Tested in Accordance with: API 598

Recommended Spare Parts*

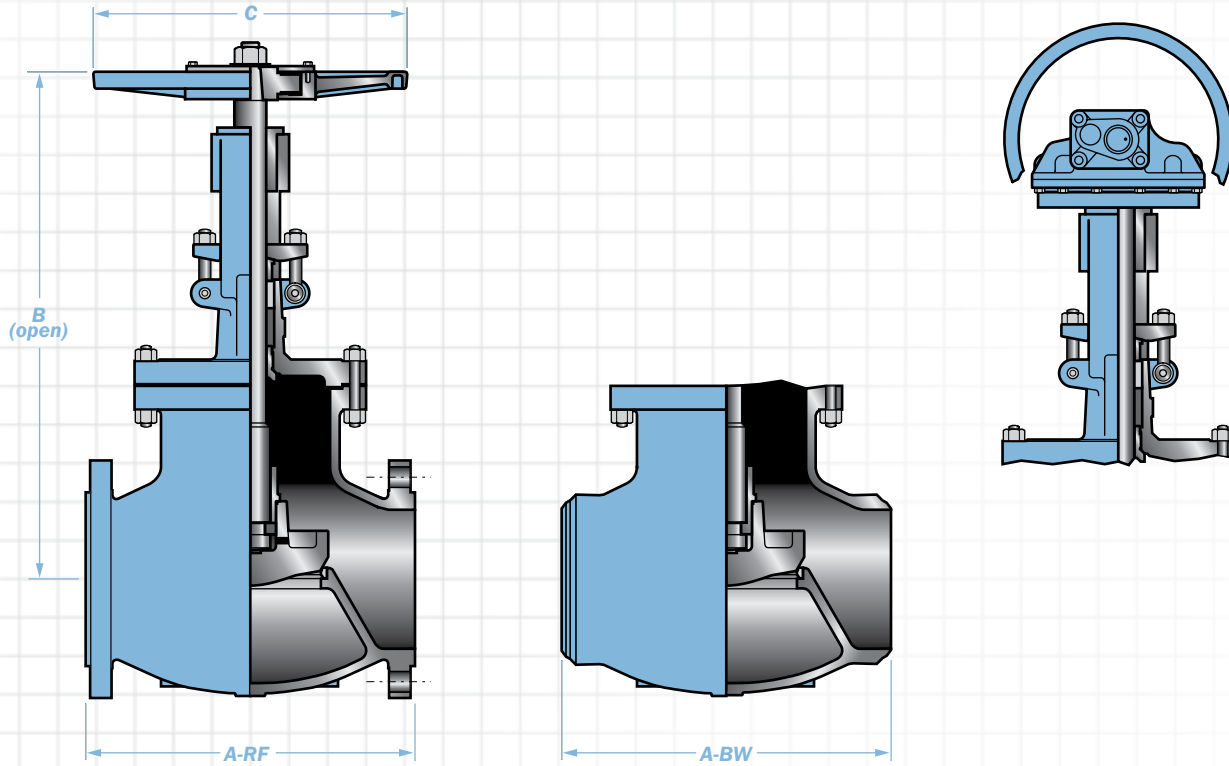

Typical Bill of Materials (See page 5 for available materials.)

Component	CB2	CB3	CB4/2	Component	CB2	CB3	CB4/2
Body	ASTM A216-WCB**			Gland Bolt Pins	ASTM A36		
Disc 2" thru 4"	ASTM A276-410	ASTM A216-WCB/ HF	ASTM A276-316	Gland Nuts	ASTM A194-2H	ASTM A194-2HM	
Disc 5" and larger	ASTM A216-WCB/ 13% Chrome		ASTM A216- WCB/316	Gland Bolts	ASTM A307-B		
Stem	ASTM A276-410		ASTM A276-316	Seat Ring	ASTM A105/HF (6" & larger)		
Bonnet	ASTM A216-WCB			Split Ring	N/A		
*Bonnet Gasket	Spiral Wound 316 Stainless Steel/Graphite			Nameplate	ASTM A666-304		
Bonnet Nuts	ASTM A194-2H	ASTM A194-2HM		Nameplate Rivets	Commercial		
Bonnet Studs	ASTM 193-B7	ASTM A193-B7M		Disc Nut	ASTM A276-410	ASTM A276-316	
Back Seat Bushing	ASTM A276-410	ASTM A276-316		Stem Nut	ASTM A439-D2		
*Packing	Graphite W/Braided Carbon Fiber End Rings			Handwheel Washer	ASTM A36		
Gland	ASTM A276-410	ASTM A276-316		Handwheel Nut	ASTM A36		
Gland Flange	ASTM A276-WCB			Handwheel	ASTM A536 (65-45-12)		
				Spacer Ring	N/A		

Class 300

Size	nps	2	2.5	3	4	5	6	8	10	12	14
A-RF	in	10.5	11.5	12.5	14.0	15.75	17.5	22.0	24.5	28.0	33.0
	mm	267	292	318	357	400	445	559	622	711	838
A-BW	in	10.5	11.5	12.5	14.0	15.75	17.5	22.0	24.5	28.0	33.0
	mm	267	292	318	357	400	445	559	622	711	838
B	in	16.9	17.8	19.2	23.0	27.4	30.6	36.2	40.8	47.3	54.3
	mm	429	452	488	584	696	777	919	1036	1201	1379
C	in	10.0	10.0	12.0	14.0	14.0	18.0	24.0	24.0	27.0	24.0
	mm	254	254	305	356	406	457	610	610	686	610
RF	lbs	75.0	100.0	130.0	203.0	294.0	421.0	715	1015	1500	2446
Wt.	kg	34	45	59	92	134	191	325	461	682	1112
BW	lbs	55	79	101	163	242	355	566	770	1218	1996
	kg	25	36	46	74	110	161	257	350	554	907

Note: Dimensions: Inches/Millimeters - Weights: Pounds/Kilograms. Larger sizes available on request. Dimensions are subject to change without notice.

** ASTM A216-WCB/HF for 2" to 4".

Rev: 032307.01

Cast Steel Bolted Cover Stop Checks

Styles: CB2, CB3, & CB4/2

Class: 600 - Sizes: 2" thru 8"

Pressure Class Range: 150 thru 1500

Design and Manufacturing Standards

Valve Design: ASME B16.34/API 600

Flange Dimensions: ASME B16.5, B16.47 (Series A)

Face-to-Face Dimensions: ASME B16.10

Tested in Accordance with: API 598

Recommended Spare Parts*

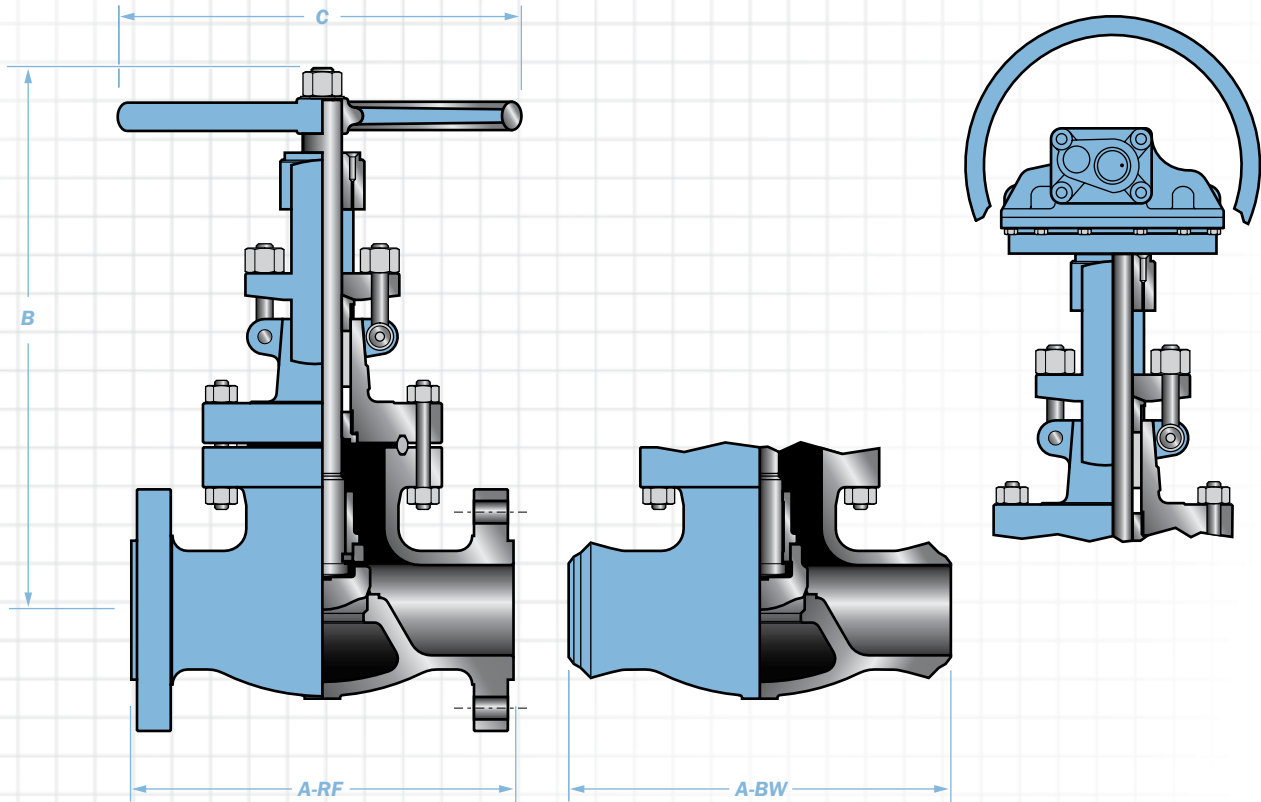

Typical Bill of Materials (See page 5 for available materials.)

Component	CB2	CB3	CB4/2	Component	CB2	CB3	CB4/2
Body	ASTM A216-WCB/HF			Gland Bolt Pins	ASTM A36		
Disc 2" thru 4"	ASTM A276-410	ASTM A216-WCB/ HF	ASTM A276-316	Gland Nuts	ASTM A194-2H	ASTM A194-2HM	
Disc 5" and larger	ASTM A216-WCB/ 13% Chrome		ASTM A216- WCB/316	Gland Bolts	ASTM A307-B	ASTM A193-B7M	
Stem	ASTM A276-410		ASTM A276-316	Seat Ring	Integral		
Bonnet	ASTM A216-WCB			Split Ring	N/A		
*Bonnet Gasket	Soft Steel Ring Joint			Nameplate	ASTM A666-304		
Bonnet Nuts	ASTM A194-2H	ASTM A194-2HM		Nameplate Rivets	Commercial		
Bonnet Studs	ASTM 193-B7	ASTM A193-B7M		Disc Nut	ASTM A276-410	ASTM A276-316	
Back Seat Bushing	ASTM A276-410	ASTM A276-316		Stem Nut	ASTM A439-D2		
*Packing	Graphite W/Braided Carbon Fiber End Rings			Handwheel Washer	ASTM A36		
Gland	ASTM A276-410	ASTM A276-316		Handwheel Nut	ASTM A36		
Gland Flange	ASTM A276-WCB			Handwheel	ASTM A536 (65-45-12)		
				Spacer Ring	ASTM A276-410		

Class 600

Size	nps	2	2.5	3	4	6	8
	dn	50	75	100	150	200	203
A-RF	in	11.5	13.0	14.0	17.0	22.0	26.0
	mm	292	325	256	435	559	660
A-BW	in	11.5	13.0	14.0	17.0	22.0	26.0
	mm	292	325	256	435	559	660
B	in	18.4	20.0	24.4	29.0	37.9	44.7
	mm	467	508	620	737	963	1135
C	in	10.0	10.0	14.0	18.0	24.0	24.0
	mm	254	254	356	457	610	610
RF	lbs	90	130	170	313	778	1245
Wt.	kg	41	59	77	142	354	566
BW	lbs	79	110	141	256	640	961
Wt.	kg	36	50	64	116	291	437

Note: Dimensions: Inches/Millimeters - Weights: Pounds/Kilograms. Larger sizes available on request. Dimensions are subject to change without notice.

Cast Steel Bolted Cover Stop Checks

Styles: CB2, CB3, & CB4/2

Class: 900 - Sizes: 2" thru 8"

Pressure Class Range: 150 thru 1500

Design and Manufacturing Standards

Valve Design: ASME B16.34/API 600

Flange Dimensions: ASME B16.5, B16.47 (Series A)

Face-to-Face Dimensions: ASME B16.10

Tested in Accordance with: API 598

Recommended Spare Parts*

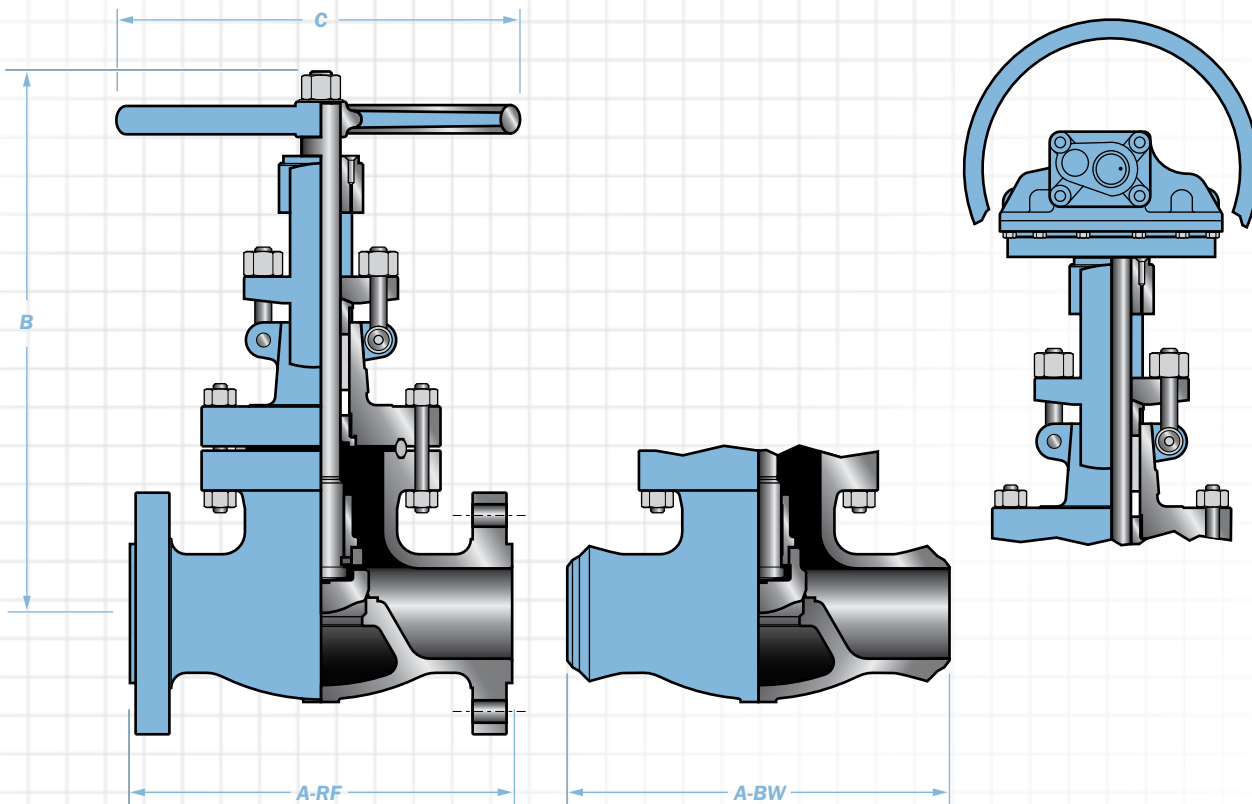

Typical Bill of Materials (See page 5 for available materials.)

Component	CB2	CB3	CB4/2	Component	CB2	CB3	CB4/2
Body	ASTM A216-WCB/HF			Gland Bolt Pins	ASTM A36		
Disc 2" thru 4"	ASTM A276-410	ASTM A216-WCB/ HF	ASTM A276-316	Gland Nuts	ASTM A194-2H	ASTM A194-2HM	
Disc 5" and larger	ASTM A216-WCB/ 13% Chrome		ASTM A216- WCB/316	Gland Bolts	ASTM A307-B	ASTM A193-B7M	
Stem	ASTM A276-410		ASTM A276-316	Seat Ring	Integral		
Bonnet	ASTM A216-WCB			Split Ring	N/A		
*Bonnet Gasket	Soft Steel Ring Joint			Nameplate	ASTM A666-304		
Bonnet Nuts	ASTM A194-2H	ASTM A194-2HM		Nameplate Rivets	Commercial		
Bonnet Studs	ASTM 193-B7	ASTM A193-B7M		Disc Nut	ASTM A276-410	ASTM A276-316	
Back Seat Bushing	ASTM A276-410	ASTM A276-316		Stem Nut	ASTM A439-D2		
*Packing	Graphite W/Braided Carbon Fiber End Rings			Handwheel Washer	ASTM A36		
Gland	ASTM A276-410	ASTM A276-316		Handwheel Nut	ASTM A36		
Gland Flange	ASTM A276-WCB			Handwheel	ASTM A536 (65-45-12)		
				Spacer Ring	ASTM A276-410		

Class 900

Size	nps	2	3	4	6	8
	dn	50	75	100	150	200
A-RF	in	14.5	15.0	18.0	24.0	29.0
	mm	368	381	457	610	737
A-BW	in	14.5	15.0	18.0	24.0	29.0
	mm	368	381	457	610	737
B	in	22.6	26.0	30.6	39.6	60.1
	mm	574	660	777	1006	1527
C	in	12.0	16.0	20.0	24.0	24.0
	mm	305	406	508	610	610
RF	lbs	198	335	440	1675	2090
Wt.	kg	90	152	200	761	950
BW	lbs	176	297	376	1144	1634
Wt.	kg	80	135	171	520	743

Note: Dimensions: Inches/Millimeters - Weights: Pounds/Kilograms. Larger sizes available on request. Dimensions are subject to change without notice.

Cast Steel Bolted Cover Stop Checks

Styles: CB2, CB3, & CB4/2

Class: 1500 - Sizes: 2" thru 8"

Pressure Class Range: 150 thru 1500

Design and Manufacturing Standards

Valve Design: ASME B16.34/API 600

Flange Dimensions: ASME B16.5, B16.47 (Series A)

Face-to-Face Dimensions: ASME B16.10

Tested in Accordance with: API 598

Recommended Spare Parts*

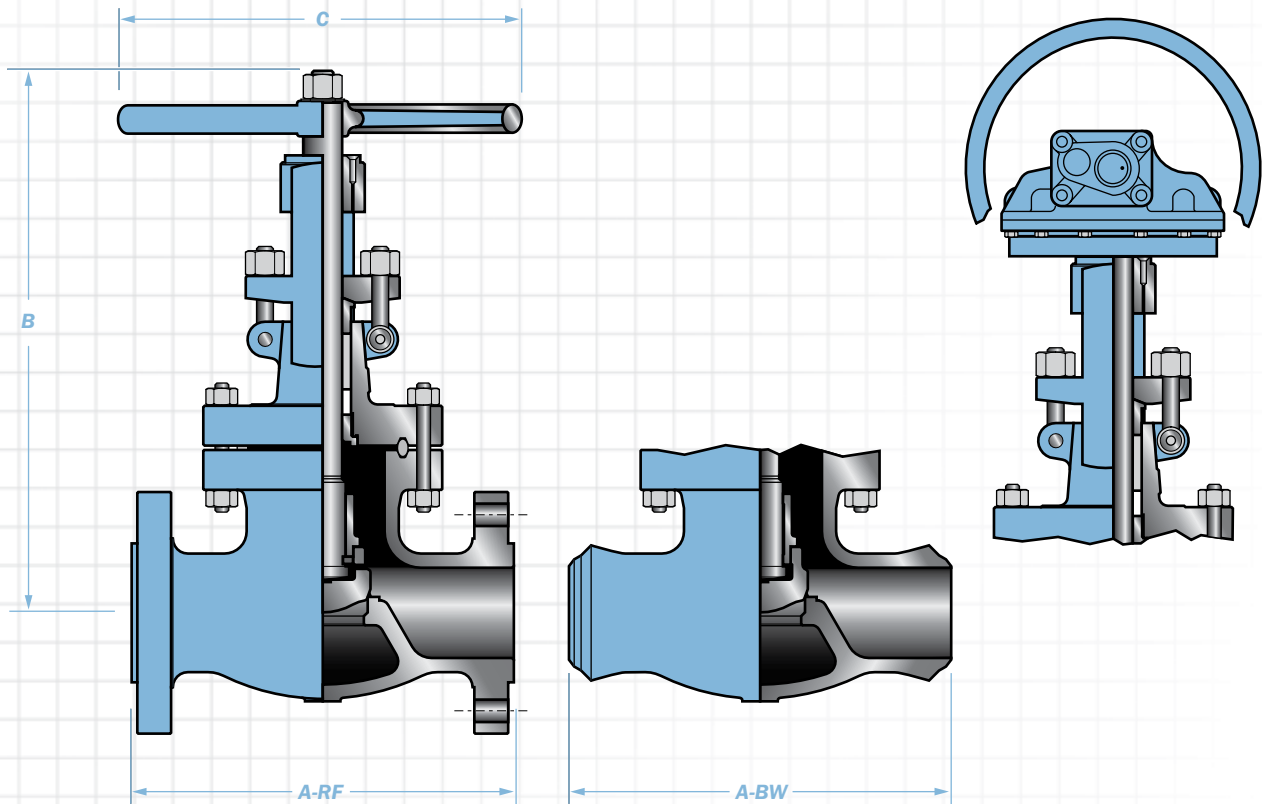

Typical Bill of Materials (See page 5 for available materials.)

Component	CB2	CB3	CB4/2	Component	CB2	CB3	CB4/2
Body	ASTM A216-WCB/HF			Gland Bolt Pins	ASTM A36		
Disc 2" thru 4"	ASTM A276-410	ASTM A216-WCB/ HF	ASTM A276-316	Gland Nuts	ASTM A194-2H	ASTM A194-2HM	
Disc 5" and larger	ASTM A216-WCB/ 13% Chrome		ASTM A216- WCB/316	Gland Bolts	ASTM A307-B	ASTM A193-B7M	
Stem	ASTM A276-410		ASTM A276-316	Seat Ring	Integral		
Bonnet	ASTM A216-WCB			Split Ring	N/A		
*Bonnet Gasket	Soft Steel Ring Joint			Nameplate	ASTM A666-304		
Bonnet Nuts	ASTM A194-2H	ASTM A194-2HM		Nameplate Rivets	Commercial		
Bonnet Studs	ASTM 193-B7	ASTM A193-B7M		Disc Nut	ASTM A276-410	ASTM A276-316	
Back Seat Bushing	ASTM A276-410	ASTM A276-316		Stem Nut	ASTM A439-D2		
*Packing	Graphite W/Braided Carbon Fiber End Rings			Handwheel Washer	ASTM A36		
Gland	ASTM A276-410	ASTM A276-316		Handwheel Nut	ASTM A36		
Gland Flange	ASTM A276-WCB			Handwheel	ASTM A536 (65-45-12)		
				Spacer Ring	ASTM A276-410		

Class 1500

Size	nps	2	3	4	6
	dn	50	75	100	150
A-RF	in	14.5	18.5	21.5	27.75
	mm	368	470	546	705
A-BW	in	14.5	18.5	21.5	27.75
	mm	368	470	546	705
B	in	19.6	25.6	30.8	36.5
	mm	498	650	782	927
C	in	9.8	17.7	19.7	25.2
	mm	249	450	500	640
RF	lbs	209	551	959	1191
Wt.	kg	95	250	436	541
BW	lbs	143	460	830	996
Wt.	kg	65	209	377	453

Note: Dimensions: Inches/Millimeters - Weights: Pounds/Kilograms. Larger sizes available on request. Dimensions are subject to change without notice.

Betcha we got what you need.

An endless supply of ready-to-ship inventory.

- **Cast Steel**
- **Cast Chrome Alloys**
- **Cast Iron**
- **Ductile Iron**
- **Forged Steel**
- **Forged Alloys**
- **Pressure Seals**
- **Trunnion Balls**
- **Floating Balls**
- **QuadroSphere® Balls**
- **Cast Exotic Alloys**
- **Forged Exotic Alloys**
- **Exotic Balls**

Newmans manufactures a complete line of **Newco** and **OIC** valve products in a full range of sizes, classes, and materials. Our newest additions are **Cooper** exotic valves and **QuadroSphere®** specialty trunnion mounted ball valves.

Newmans has been supplying quality valves to the world's hydrocarbon, pulp & paper, marine, power, chemical, mining, and general industries for more than 60 years. **Newmans** manufactures and inventories gate, globe, check, ball, and specialty valves in sizes from 1/2" thru 60" in diameter and in pressure classes from 125 thru 4500 lbs. in most alloys.

Newmans' world-wide production facilities are certified to the requirements of the ISO 9001:2000 Standard and are compliant to the industry standards of API, ASTM and ASME. All **Newmans** products are manufactured, inspected, and tested in accordance to the most rigid quality standards as well as specific customer requirements.

So, whether it's cast steel for general service or exotic alloys for corrosive applications or metal seated ball valves for severe service applications, **Newmans** is "The Reliable Source" for all your valve needs.

- Engineered solutions
- Complete alloy coverage
- Ready-to-ship inventories
- Competitive factory lead times
- Sizes: 1/2" thru 60" & Classes: 125 thru 4500

Please visit our web site at www.NewmansValve.com to see our complete line of **Newco**, **Cooper**, & **OIC** valves.

Featuring **Newmans' Newco Cast Steel** product line.



Newmans®
The Reliable Source

Toll Free: 800.231.3505
www.NewmansValve.com

Newco®

Cast Steel Bolted Bonnet Angle Stop Check Valves

Manufactured by Newmans™

Sizes: 2" thru 12" • Pressure Class: 150 thru 600



Typical Newco Cast Steel Bolted Bonnet Angle Stop Check Valve Expanded View

1. Body: Newco cast steel bodies provide low resistance flow and optimum strength and performance.

2. Bonnet: Newco bonnet assemblies are built to the same standards as the bodies.

3. Back Seat Bushing: The back seat, when engaged with the stem head, provides a stable shutoff to the stuffing box which isolates the packing from flow exposure.

4. Stem: The stem inserts vertically into the disc.

5. Disc: Newmans 1-piece disc is machined to the tightest tolerances to ensure trouble free shutoff and cycling.

6. Disc Nut: The disc nut serves as a mechanical guide acting on the stem to ensure proper alignment of the disc to the seat.

7. Gland: Compresses the packing to create a stem seal above the back seat, between the bonnet and stem.

8. Gland Flange: Applies pressure to the gland for accurate packing adjustments.

9. & 10. Gland Bolts & Nuts: The gland bolt and nut allows for easy adjustments for packing compression.

11. Gland Bolt Pin: The gland bolt pin secures the gland bolts to the yoke & bonnet.

12. Packing: The packing creates a seal above the back seat, between the bonnet and stem.

13. Stuffing Box: The stuffing box contains the packing.

14. Stem Nut: The stem nut provides a precision guide for proper stem alignment.

15. Handwheel: The handwheel cycles the valve.

16. Handwheel Nut: The handwheel nut secures the handwheel to the bonnet assembly.

17. Handwheel Washer: The washer helps to prevent loosening or distributes pressure evenly.

18. Bonnet Gasket: The bonnet gasket creates a leakproof seal between the bonnet and body.

19. & 20. Bonnet Studs & Nuts: The bonnet studs and nuts secure the bonnet to the body.

21. Seat Ring: To ensure a stable shutoff, the seat ring is aligned and seal-welded into the valve, then precision ground for optimal seating.

22. Disc Guide: The disc guides provide a stable track for keeping the disc aligned with the seat during cycling.

23. Spacer Ring: Assists the packing rings in creating a seal above the back seat, between the bonnet and stem.

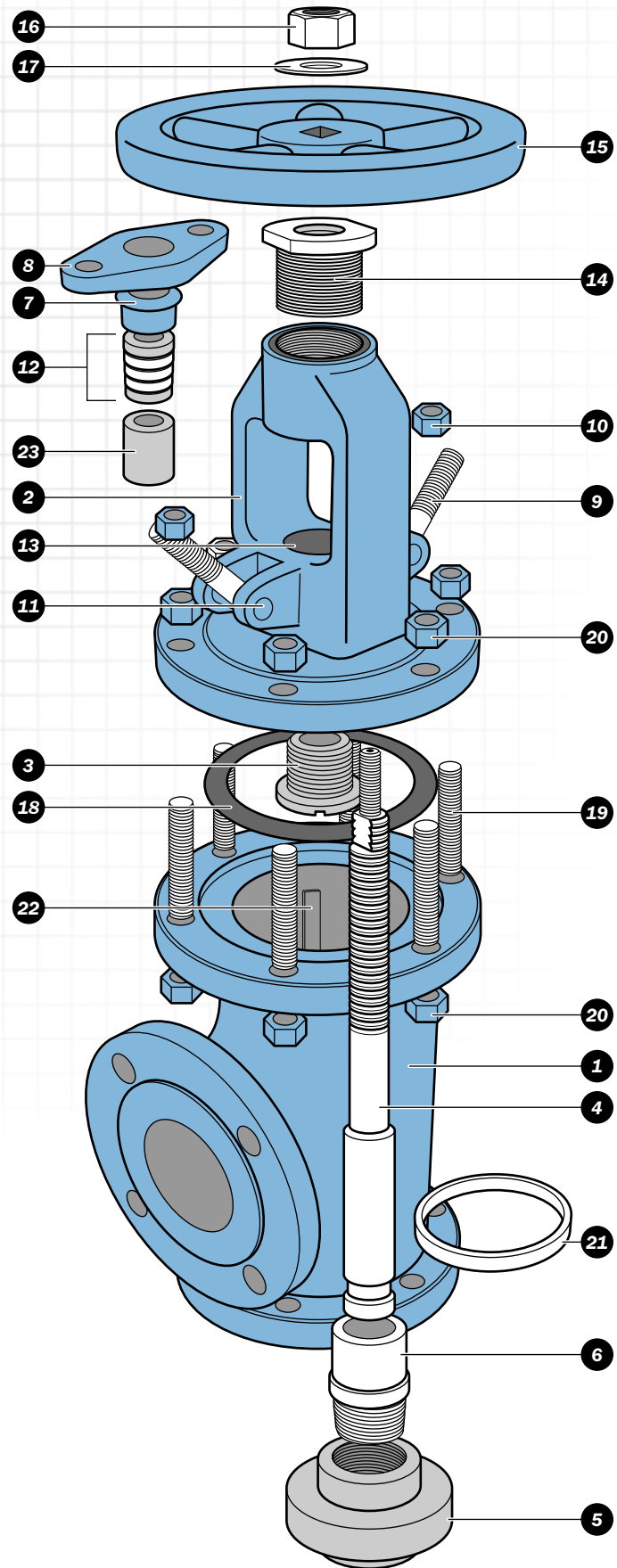

Cast Steel Bolted Bonnet Angle Stop Checks

Styles: CB2, CB3, & CB4/2

Class: 150 - Sizes: 2" thru 12"

Pressure Class Range: 150 thru 600

Design and Manufacturing Standards

Valve Design: ASME B16.34/API 600

Flange Dimensions: ASME B16.5, B16.47 (Series A)

Face-to-Face Dimensions: ASME B16.10

Tested in Accordance with: API 598

Recommended Spare Parts*

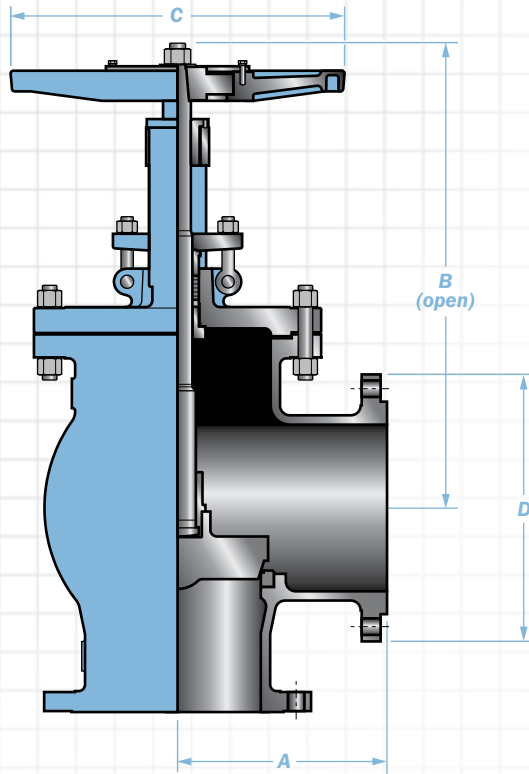

Typical Bill of Materials (See page 5 for available materials.)

Component	CB2	CB3	CB4/2	Component	CB2	CB3	CB4/2
Body	ASTM A216 GR.WCB			Packing	Die Formed Graphite with Braided Graphite End Rings		
Seat Ring	ASTM A105			Gland Bolt Pins	Commercial		
Disc	ASTM A276 - 410			Gland Bolts	ASTM A193 GR.B7		
Disc Nut	ASTM A276 - 410			Gland	ASTM A276 - 410		
Stem	ASTM A182 F6a			Gland Flange	ASTM A216 GR.WCB		
*Bonnet Gasket	Spiral Wound 316 Stainless Steel/Graphite			Gland Bolt Nuts	ASTM A194 GR.2H		
Bonnet	ASTM A216 GR.WCB			Stem Nut	ASTM A439 GR.D-2		
Bonnet Studs	ASTM A193 GR.B7			Split Ring	N/A		
Bonnet Nuts	ASTM A194 GR.2H			Handwheel	ASTM A539 Type 60-40-18		
Back Seat Bushing	ASTM A276 - 410			Handwheel Nut	Commercial		
Spacer Ring	ASTM A276 - 410			Handwheel	Commercial		

Class 150

Size	nps	2	3	4	6	8	10	12
	dn	50	75	100	150	200	250	300
A	in	4.0	4.75	5.75	8.0	9.75	12.25	13.75
	mm	107	121	146	203	248	311	349
B	in	15.2	16.9	20.4	21.8	27.4	31	37.8
	mm	386	429	518	554	696	787	960
C	in	8	10	12	15	18	22	24
	mm	203	254	305	381	457	559	610
D	in	6	7.5	9	11	13.5	16	19
	mm	152	191	229	279	343	406	483
RF	lbs	57	84	141	234	399	611	794
Wt.	kg	125	185	310	515	878	1344	1747

Note: Dimensions: Inches/Millimeters - Weights: Pounds/Kilograms. Larger sizes available on request. Dimensions are subject to change without notice.

Cast Steel Bolted Bonnet Angle Stop Checks

Styles: CB2, CB3, & CB4/2

Class: 300 - Sizes: 2" thru ?"

Pressure Class Range: 150 thru 600

Design and Manufacturing Standards

Valve Design: ASME B16.34/API 600

Flange Dimensions: ASME B16.5, B16.47 (Series A)

Face-to-Face Dimensions: ASME B16.10

Tested in Accordance with: API 598

Recommended Spare Parts*

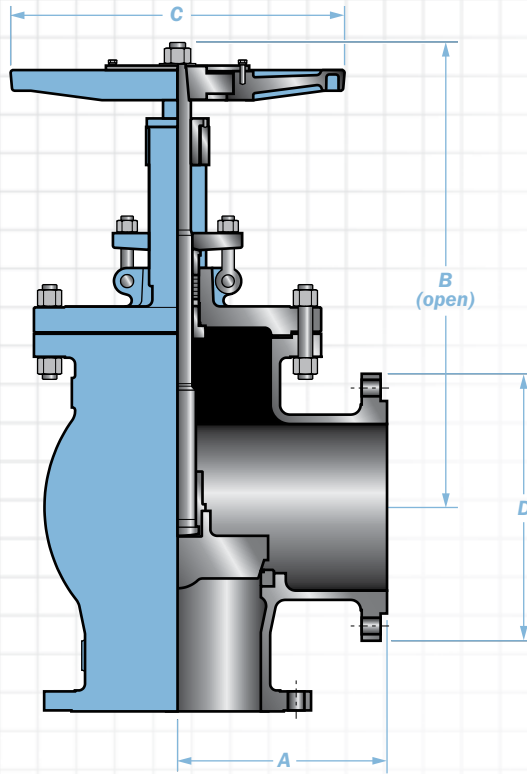

Typical Bill of Materials (See page 5 for available materials.)

Component	CB2	CB3	CB4/2	Component	CB2	CB3	CB4/2
Body	ASTM A216 GR.WCB			Packing	Die Formed Graphite with Braided Graphite End Rings		
Seat Ring	ASTM A105			Gland Bolt Pins	Commercial		
Disc	ASTM A276 - 410			Gland Bolts	ASTM A193 GR.B7		
Disc Nut	ASTM A276 - 410			Gland	ASTM A276 - 410		
Stem	ASTM A182 F6a			Gland Flange	ASTM A216 GR.WCB		
*Bonnet Gasket	Spiral Wound 316 Stainless Steel/Graphite			Gland Bolt Nuts	ASTM A194 GR.2H		
Bonnet	ASTM A216 GR.WCB			Stem Nut	ASTM A439 GR.D-2		
Bonnet Studs	ASTM A193 GR.B7			Split Ring	N/A		
Bonnet Nuts	ASTM A194 GR.2H			Handwheel	ASTM A539 Type 60-40-18		
Back Seat Bushing	ASTM A276 - 410			Handwheel Nut	Commercial		
Spacer Ring	ASTM A276 - 410			Handwheel	Commercial		

Class 300

Size	nps dn	2	3	4	6	8	10	12
		50	75	100	150	200	250	300
A	in	5.25	6.25	7	8.75	11	12.25	14
	mm	133	159	178	222	279	311	356
B	in	15	16.9	21.7	28	30.7	37.5	41.6
	mm	381	429	551	711	780	953	1049
C	in	10	12	14	17	24	24	27
	mm	254	305	356	432	610	610	686
D	in	6.5	8.25	10	12.5	15	17.5	20.5
	mm	165	210	254	318	381	445	521
RF Wt.	lbs	68	108	198	392	560	934	1288
	kg	150	238	436	862	1232	2055	2837

Note: Dimensions: Inches/Millimeters - Weights: Pounds/Kilograms. Larger sizes available on request. Dimensions are subject to change without notice.

Cast Steel Bolted Bonnet Angle Stop Checks

Styles: CB2, CB3, & CB4/2

Class: 600 - Sizes: 2" thru ?"

Pressure Class Range: 150 thru 600

Design and Manufacturing Standards

Valve Design: ASME B16.34/API 600

Flange Dimensions: ASME B16.5, B16.47 (Series A)

Face-to-Face Dimensions: ASME B16.10

Tested in Accordance with: API 598

Recommended Spare Parts*

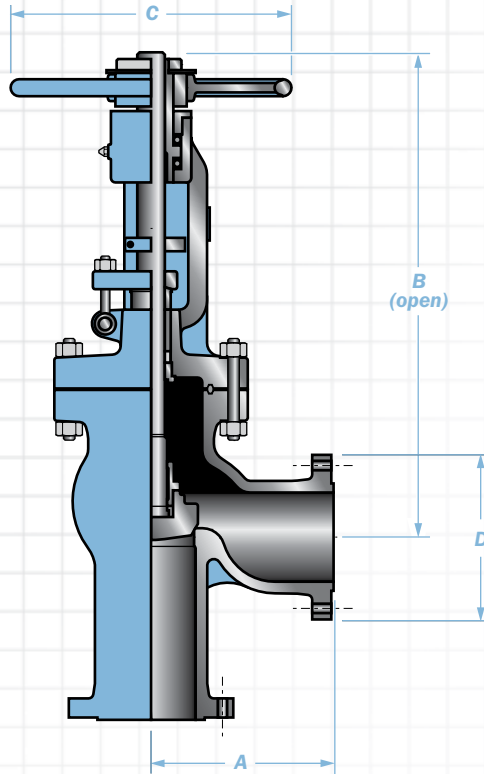

Typical Bill of Materials (See page 5 for available materials.)

Component	CB2	CB3	CB4/2	Component	CB2	CB3	CB4/2
Body		ASTM A216 GR.WCB		Packing	Die Formed Graphite with Braided Graphite End Rings		
Seat Ring		ASTM A105		Gland Bolt Pins	Commercial		
Disc		ASTM A276 - 410		Gland Bolts	ASTM A193 GR.B7		
Disc Nut		ASTM A276 - 410		Gland	ASTM A276 - 410		
Stem		ASTM A182 F6a		Gland Flange	ASTM A216 GR.WCB		
*Bonnet Gasket		Soft Steel Ring Joint		Gland Bolt Nuts	ASTM A194 GR.2H		
Bonnet		ASTM A216 GR.WCB		Stem Nut	ASTM A439 GR.D-2		
Bonnet Studs		ASTM A193 GR.B7		Split Ring	N/A		
Bonnet Nuts		ASTM A194 GR.2H		Handwheel	ASTM A539 Type 60-40-18		
Back Seat Bushing		ASTM A276 - 410		Handwheel Nut	Commercial		
Spacer Ring		ASTM A276 - 410		Handwheel	Commercial		

Class 600

Size	nps dn	2	2.5	3	4	6	8
		50	75	100	150	200	250
A	in	5.75	6.5	7.0	8.5	11.0	13.0
	mm	146	165	178	216	279	330
B	in	18.9	20.9	19.8	22.2	28.2	38.5
	mm	480	531	503	564	716	978
C	in	8.8	9.8	11.0	14.0	17.7	24.8
	mm	224	249	279	356	450	630
D	in	6.5	7.5	8.3	9.0	14.0	16.5
	mm	165	191	211	229	356	419
RF	lbs	79	110	141	256	640	961
Wt.	kg	36	50	64	116	291	437

Note: Dimensions: Inches/Millimeters - Weights: Pounds/Kilograms. Larger sizes available on request. Dimensions are subject to change without notice.

Limited Warranty

Newmans warrants to the original purchaser, for a period of one year from and after the date of delivery to the original customer, that its products will be free from defects in workmanship and materials, not caused or resulting from improper usage or application, improper installation, improper maintenance, repair modification or alterations.

In the event the original purchaser shall determine that a product purchased from Newmans shall be defective in workmanship or materials, the customer shall notify the Newmans Warranty Representative by telephone (713) 675-8631 within 24 hours from such determination, followed by written notice to such effect within 7 days therefrom, addressed to:

Newmans
1300 Gazin Street
Houston, Texas 77020

In the event Newmans shall determine that the product is defective as a result of factory workmanship, based upon such examination of the product which Newmans may deem appropriate, Newmans shall thereupon, at its sole option, (a) cause the defective product to be repaired, (b) replaced with a substantially identical product, or (c) accept the return of a defective product and refund the purchasing price to the original purchaser. Newmans shall bear all normal surface transportation costs to the original purchaser but shall in no event bear any installation, re-installation, engineering or other costs incurred in connection with repair or replacement.

Unless Newmans shall have provided engineering and/or suitability of application or installation services for a purchaser, for which a separate charge shall have been specifically identified and made, the selection, suitability, installation and fitness of all products sold by Newmans shall be deemed to have been determined exclusively by and within the sole discretion of the purchaser. Accordingly, Newmans disclaims any obligation, warranty or guarantee in any manner relating to or resulting from the selection, application, suitability, fitness or installation of its products.

The foregoing constitutes the sole obligation of Newmans with respect to defective products purchased from it and in no manner shall Newmans assume or be liable for any other expenses, incidental or consequential damages, losses, lost profits, down time or otherwise, whether directly or indirectly suffered, or in any other manner relating to or as the result of any defect or failure or any product that it may sell.

Except as otherwise provided herein, NEWMANS MAKES NO WARRANTIES OR REPRESENTATIONS, WHETHER EXPRESSED OR IMPLIED, OF ANY KIND WHATSOEVER WITH RESPECT TO GOODS AND PRODUCTS SOLD BY IT, INCLUDING WITHOUT LIMITATION, ANY WARRANTIES WITH RESPECT TO MERCHANTABILITY OR FITNESS FOR A PARTICULAR PURPOSE. NO PERSON IS AUTHORIZED TO GRANT OR EXTEND ANY WARRANTY OR REPRESENTATION ON BEHALF OF NEWMANS OTHER THAN AS SET FORTH HEREIN.

Industry Standards Typically Used in Valve Manufacturing

(For Reference Only)

ISO 9001: 2000

RWTUV had approved Newmans for design, manufacture, sales, & service of industrial valves under certificate registration number #05-1026

American Petroleum Institute (API)

API RP 574 (1998) - Inspection practices for piping system components
 API 589 (1998) - Fire test for evaluation of valve stem packing
 API RP 591 (2003) - Process valve qualification procedure
 API 594 (2004) - Check valves-flanged, lug, wafer & buttwelding
 API 597 (1981) - Steel venturi gate valves, flanged, buttwelding ends
 API 598 (2004) - Valve inspection & testing
 API 599 (2002) - Metal plug valves - flanged, welding ends
 API 601 (1988) - Metallic gaskets for raised-face pipe flanges & flanged connections (double-jacketed corrugated & spiral wound)
 API 600 (2001) - Bolted bonnet steel gate valves for petroleum & natural gas industries "ISO adoption from ISO 10434"
 API 602 (2005) - Steel gate, globe, & check valves for sizes DN100 and smaller for the petroleum & natural gas industries
 API 603 (2001) - Corrosion-resistant, bolted bonnet gate valves-flanged & buttweld ends
 API 604 (1981) - Ductile iron gate valves, flanged ends
 API 605 (1988) - Large-diameter carbon steel flanges (nominal pipe sizes 26" through 60", classes 75, 150, 300, 400, 600, & 900 (replaced by ANSI/ASME B16.47)
 API 606 (1989) - Compact steel gate valves, extended body (included in API 602) fire test for soft-seated quarter-turn valves "ISO adoption from ISO 10497-5 2004"
 API 607 (2005) - Fire test for soft-seated quarter-turn valves "ISO adoption from ISO 10497-5 2004"
 API 608 (2002) - Metal ball valves, flanged, threaded, & welding ends
 API 609 (2004) - Butterfly valves-double flanged, lug- & wafer-type
 API RP 941 (2004) - Steel for hydrogen service at elevated temperatures & pressures in petroleum refineries & petrochemical plants
 API RP 520 (2000), Part 1 - Sizing, selection & installation of pressure relieving devices in refineries
 API RP 520 (2003), Part 2 - Sizing, selection & installation of pressure relieving devices in refineries devices in refineries
 API Spec 6A (2005) - Specification for wellhead & christmas tree equipment
 API Spec 6D (2005) - Specifications for pipeline valves
 API Spec 14D (1994) - Specifications for wellhead surface safety valves & underwater safety valves for offshore service
 API 5B (2004) - Threading, gauging thread inspection of coring, tubing, & line pipe threads
 API 6AM (2003) - Material toughness
 API 6FA (1999) - Fire test for valves
 API 6FC (1999) - Fire test for valves with backseats
 API 6FD (1995) - Specification for fire test for check valves
 API Q1 (2003) - Specification for quality programs for the petroleum, petrochemical, & natural gas

American Society of Mechanical Engineers (ASME)

ASME Code (1997 addenda) - Boiler & pressure vessel code
 ASME A13.1 (1996) - Scheme for the identification of piping systems
 ASME B1.1 (2003) - Unified inch screw threads, UN, & UNR thread form
 ASME B1.5 (1997) - ACME screw threads
 ASME B1.7M (1984) - Nomenclature, definitions, & letter symbols for screw threads
 ASME B1.8 (1988) - Stub ACME screw threads
 ASME B1.12 (1987) - Class 5 interference - fit thread
 ASME B1.20.1 (1983) - Pipe threads, general purpose, inch
 ASME B1.20.3 (1976) - Dry-seal pipe threads, inch
 ANSI/ASME B16.1 (1998) - Cast iron pipe flanges & flanged fittings
 ANSI/ASME B16.5 (2003) - Pipe flanges & flanged fittings: NPS 1/2" through 24"
 ASME B16.9 (2003) - Factory made wrought steel buttwelding fittings
 ANSI/ASME B16.10 (2002) - Face-to-face & end-to-end dimensions of valves
 ASME B16.11 (2001) - Forged fittings, socket welding & threaded
 ASME B16.20 (1998) - Metallic gaskets for pipe flanges: ring joint spiral wound & jacketed
 ASME B16.21 (2005) - Non-metallic flat gaskets for pipe flanges
 ASME B16.25 (2003) - Buttwelding ends
 ANSI/ASME B16.33 (2002) - Manually operated metallic gas valves for use in gas piping systems up to 125 PSI (sizes NPS 1/2" through 2")
 ANSI/ASME B31.1 (2004) - Power piping
 ANSI/ASME B31.3 (2004) - Process piping
 ANSI/ASME B16.34 (2004) - Valves flanged, threaded & welding end
 ANSI/ASME B16.36 (1996) - Orifice metallic
 ANSI/ASME B16.38 (1985) - Large metallic valves for gas distribution (manually operated, NPS 2-1/2" through 12", 125 PSIG maximum)
 ANSI/ASME B16.42 (1998) - Ductile iron pipe flanges & flanged fittings: classes 150 & 300
 ANSI/ASME B16.47 (1996) - Large diameter steel flanges
 ANSI B17.1 (1967, R' 89) - Keys & keyseats
 ANSI B18.2.2 (1987) - Square & hex nuts
 ASME B31.4 (2002) - Pipeline transportation systems for liquid hydrocarbons & other ammonia & alcohols
 ANSI/ASME B31.8 (2003) - Gas transmission & distribution piping systems
 ANSI/ASME B36.10 (2004) - Welded & seamless wrought steel pipe
 ANSI/ASME B36.19 (2004) - Stainless steel pipe
 ANSI FCI-2 (1991) - Control valve seat leakage

American Society Non-destructive Test (ASNT)

ASNT-TC-1A (1996) - Recommended practice no. SNT-TC-1A 1996

American Society for Testing and Materials (ASTM)

Rev: 032307.01

British Standards Institute (BS)

BS 1414 (1975, R' 91) - Gate, wedge & double disk valves: steel
 BS 1868 (1975, R' 91) - Check valves: steel
 BS 1873 (1975, R' 91) - Globe & check valves: steel
 BS 2080 (1989) obsolete - Flanged & buttweld end steel valves
 BS 5146 - (withdrawn) Replaced by BS 6755 p.1 steel valves testing (1986) & BS 6755 p.2 (1984)
 BS 5152 (1974, R' 91) - Globe & check: cast iron
 BS 5153 (1974, R' 91) - Check: cast iron
 BS 5159 (1974, R' 91) - Ball: cast iron & carbon steel
 BS 5160 (1974, R' 91) - Globe & check: steel
 BS 5163 (1986, R' 91) - Gate, wedge & double disk: cast iron
 BS 5351 (1986, R' 91) - Ball: steel
 BS 5352 (1986, R' 91) - Globe & check: steel
 BS 5418 - (withdrawn) Replaced by BS EN 19 (1992) marking: general purpose industrial
 BS 5840 (1980, R' 91) - Valve mating details for actuator operation
 BS 6364 (1984, R' 91) - Cryogenic
 BS 6683 (1985, R' 91) - Guide: installation & use of valves
 BS 6755: Part 1 (1986, R' 91) - Specification for production pressure testing requirements
 BS 6755: Part 2 (1987) - Specification for fire type-testing requirements
 BS EN 19 (1992) - Marking of general purpose industrial valves

Canadian Standards Association

B51.97 - Boiler, pressure vessel, & pressure piping code
 Z245.15-96 - Steel valves
 CAN3-z299.4-85 (reaffirmed 1997) - Quality assurance program - Category 4
 CAN3-z299.3-85 (reaffirmed 1997) - Quality assurance program - Category 3

International Organization for Standardization

ISO 5211/1 (2001) - Industrial valves- part-turn actuator attachments
 ISO 5211/2 (2001) - Part-turn valve actuator attachment-flange & coupling performance characteristics
 ISO 5211/3 (2001) - Part-turn valve actuator attachment-dimensions of driving components
 ISO 5752 (1982) - Metal valves for use in flanged pipe systems face-to-face & center-to-face dimensions
 ISO 9000 (2005) - Quality management systems and fundamentals & vocabulary
 ISO 10012-1 (1992) - Quality assurance requirements for measuring equipment

Manufacturers Standardization Society

SP-6 (2001) - Standard finishes for contact faces of pipe flanges & connecting-end flanges of valves & fittings
 SP-9 (r2005) - Spot facing for bronze, iron & steel flanges
 SP-25 (1998) - Standard marking system for valves, fittings, flanges & unions
 SP-42 (2004) - Class 150 corrosion resistant gate, globe, angle, & check valves with flanged & buttweld ends
 SP-44 (2001) - Steel pipeline flanges
 SP-45 (2003) - Bypass & drain connections
 SP-51 (2003) - Class 150/w corrosion resistant cast flanges & flanged fittings
 SP-53 (2002) - Quality standard for steel castings & forgings for valves, flanges, & fittings & other piping components: magnetic particle exam method
 SP-54 (2002) - Quality standard for steel castings for valves, flanges, & fittings and other piping components: radiographic examination method
 SP-55 (2001) - Quality standard for steel castings for valves, flanges other piping components-visual method for evaluation of surface irregularities
 SP-60 (2004) - Connecting flange joint between tapping sleeves & tapping valves
 SP-61 (2003) - Pressure testing of steel valves
 SP-65 (2004) - High pressure chemical industry flanges & threaded stubs for use with lens gaskets
 SP-67 (2000A) - Butterfly valves
 SP-69 (2003) - ANSI/MSS edition pipe hangers & supports, selection & application
 SP-70 (1998) - Cast iron gate valves, flanged & threaded ends
 SP-71 (1997) - Gray iron swing check valves, flanged & threaded ends
 SP-72 (1999) - Ball valves with flanged or butt-welding ends for general service
 SP-79 (2004) - Socket-welding reducer inserts
 SP-81 (2001) - Stainless steel, bonnetless, flanged knife gate valves
 SP-82 (1992) - Valve pressure testing methods
 SP-84 (1990) - Valves - socket welding & threaded ends
 SP-85 (2002) - Cast iron globe & angle valves, flanged & threaded ends
 SP-86 (2002) - Guidelines for metric data in standards for valves, flanges, fittings & actuators
 SP-88 (r2001) - Diaphragm valves
 SP-91 (1992) - Guidelines for manual operation of valves
 SP-92 (1999) - MSS valve user guide
 SP-93 (r2004) - Quality standard for steel castings & forgings for valves, flanges & fittings & other piping components- liquid penetrant exam method
 SP-94 (r2004) - Quality standard for ferritic & martensitic steel castings for valves, flanges, & fittings and others piping components - ultrasonic exam method
 SP-96 (r2005) - Guidelines on terminology for valves & fittings
 SP-98 (2001) - Protective coatings for the interior of valves, hydrants, & fittings
 SP-99 (r2005) - Instrument valves
 SP-101 (r2001) - Part-turn valve actuator attachment-flange and driving component dimensions & performance characteristics
 SP-102 (r2001) - Multi-turn valve actuator attachment: flange and driving component dimensions & performance characteristics
 SP-110 (1996) - Ball valves threaded, socket-welding, solder joint, grooved, & flared ends
 SP-117 (2002) - Bellows seals for globe & gate valves
 SP-118 (2002) - Compact steel globe and check valves-flanged, flangeless, threaded & welding ends (chemical & petroleum refinery service)
 SP-120 (2002) - Flexible graphite packing system for rising stem steel valves (design requirements)
 SP-121 (R2002) - Qualification testing methods for stem packing for rising stem steel valves

National Association of Corrosion Engineers (NACE)

MR0175 (2005) - Sulfide stress cracking resistant metallic materials for oil field equipment
 MR0103 (2005) - Materials resistant to sulfide stress cracking in corrosive petroleum refining environments

Terms & Conditions

Definitions

- 1) Supplier**
"Supplier" refers to NEWCO Valves LP dba NEWMANS, a Texas (USA) limited partnership, and all of its affiliated or related entities, including, but not limited to, its parent, subsidiary, affiliated companies, their officers, directors, employees and agents, individually and collectively.
- 2) Customer**
"Customer," refers to all of the following:
 - a) any party acting as agent for the Customer, the party ordering goods or services on behalf of himself, herself or itself and others;
 - b) the person signing Supplier's credit application, service order, bill of lading, delivery receipt or ticket;
 - c) the store, factory, warehouse, shipping company, accepting agent, contractor or subcontractor of the job site, store, warehouse, transportation company, accepting agent;
 - d) the person accepting and/or ordering Supplier's goods and services acknowledges that he or she has the actual and apparent agency authority to bind the Customer and owner of the property the product will improve, to the terms and conditions of this agreement, all of whom are included in the term "Customer"; and
 - e) the person paying the invoices of Supplier, signing Supplier's service orders, delivery tickets, bills of lading or other Supplier contracts, acknowledges that he or she is the agent of the Customer and/or any entity who is benefited by the Supplier's product, and that they are said person's agent.
- 3) Equipment**
"Equipment" refers to any goods and service, item of supply or equipment or property ordered or purchased by Customer or the Customer's agent from Supplier or provided by Supplier, including, but not limited to: valves, pipe, fittings, product or general equipment, supplies, parts, materials, supplies and/or merchandise sold by Supplier or provided in connection with Supplier's provider capabilities or needed by Supplier to assist Supplier in the performance and delivery of its product to Customer, but "Equipment" excludes "Services" as defined below.
- 4) Services**
"Service(s)" refers to all employees or agents furnished by Supplier as consultants and/or to perform any function, including the operation of equipment which performs any function, trucks or other merchandise necessary to perform any function when operated by Customer's employees or agents or the Supplier's employees or agents on Customer's job or to satisfy the Customer's order or orders.
- 5) Claims**
"Claim(s)" refers to all of the following:
 - a) any liability of Supplier to Customer; b) loss of equipment, time, money, or profit of Supplier; and c) claim, demand, cause of action, proceeding, damage to person, damage to personal or real property, damage and penalty, including attorney's fees, costs and expenses.
- 6) Price Book, Price List, Manual, & Credit Application**
Customer agrees to be bound by all relevant provisions of the following:
 - a) "Supplier's Price Book" and "Price Book" refer to the current book published by Supplier which may list the Supplier's contractual terms and conditions, lists prices for Equipment and Services offered by Supplier, including all amendments;
 - b) "Supplier's Manual," "Manual" and "Employee Manual" refer to any manual of Supplier governing, which may contain its contractual terms and conditions, the procedures for pricing Equipment and Services of Supplier, or the manner in which Supplier is to provide goods or services plus all amendments and updates. Customer agrees to be bound by such terms and conditions, procedures; and
 - c) "Supplier's Credit Application" and "Credit Application" refer to any application or request submitted by Customer to Supplier for the purpose of seeking the extension of credit by Supplier and which may contain the Supplier's terms and conditions all of which shall be binding on the Customer.

General Terms & Conditions

Customer acknowledges that it has reviewed and agrees to be bound by the above and following (Definitions, Terms and Conditions and all of the language contained herein and in related documents described elsewhere herein) whenever it or its employees, transportation and/or warehouse company, its customer or end user, and/or agent either: i) accepts the Equipment or Services of Supplier; or ii) signs a Credit Application, service order, delivery ticket, bill of lading or contract for goods or services; or iii) receives an invoice from Supplier and/or orders more Equipment or Services from Supplier.

- 1) Entire Contract**
The Terms and Conditions herein, in the invoice, acknowledgement or acceptance of Customer's order, Price Book, Manual and Credit Application as defined above and elsewhere herein, the other documents aforementioned, all of which are incorporated herein by reference for all purposes, constitute the entire contract ("Contract") between the parties and may not be amended except in writing signed by Supplier's authorized representative.
- 2) Controlling Terms and Conditions**
Equipment or Services furnished to Customer by Supplier or its agents will be controlled only by the Terms and Conditions contained herein and contained in the other documents of Supplier mentioned herein and these are the only terms and conditions to which these parties shall be bound. In the event that Customer writes any letters or uses any other document generated by Customer to order or accept Supplier's Equipment or Services, the Terms and Conditions contained herein shall control and this document does hereby serve as an objection thereto.

- 3) Failure of Any Party to Enforce**
The failure of either party to enforce any provision hereof will not constitute a waiver or preclude subsequent enforcement thereof.
- 4) Invalidity of Any Term or Condition Contained Herein**
No partial invalidity of this Contract will affect the remainder. In the event that any term or condition contained herein is found to be invalid, the parties agree that the remainder of Supplier's contract shall remain valid.
- 5) Jurisdiction and Venue; Construction of Terms and Conditions**
The Parties hereto agree that the terms and conditions of Supplier's documents mentioned herein and the Terms and Conditions of this document shall be construed in accordance with the laws of the State of Texas or, if offshore, in accordance with General Maritime Law of the United States, without giving effect to respective conflicts of law principals, or Supplier at its exclusive option may choose the Jurisdiction to interpret the terms and conditions contained herein and in the other documents mentioned herein. In the event of litigation between Customer and Supplier, Customer hereby waives any claim it may have to any jurisdiction and venue other than that chosen by Supplier. Customer agrees that it is to perform its obligations herein in Houston, Harris County, Texas, non-exclusively to include payment. Canada: Whenever the facts of a particular contract would in the sole opinion of the Supplier be best litigated in Canada, the parties agree that Supplier can choose that jurisdiction and that Supplier can choose any venue it deems appropriate in Canada. All the other terms and conditions contained in this document shall then apply in Canada as if this agreement was in the United States of America.
- 6) Credit**
Terms are cash in advance unless credit is approved in writing prior to the sale. If credit is approved, Customer must maintain credit satisfactory to Supplier. When Customer or its agent signs any of Supplier's documents in the process of ordering or receiving Equipment or Services from Supplier, it states for Supplier's reliance that it has the current ability to pay for the Equipment or Services ordered or accepted and it further agrees that Supplier reserves the right to require Customer to furnish security for performance of Customer's obligations. Payments shall be made in U.S. Dollars net 30 days at Supplier's address in Houston, Harris County, Texas. If credit terms are not met or Customer otherwise fails to follow the Terms and Conditions contained herein, in addition to its other legal rights, Supplier may and Customer hereby authorizes Supplier to: a) defer or cancel further shipments of Equipment or Services and/or otherwise decline to provide its product to Customer; b) enter upon any property or job site on which the Equipment of Supplier is located by taking any necessary action, including, but not limited to, opening gates, cutting locks, cutting chains; c) authorize any other company to remove its equipment from any location, to the extent needed for Supplier to be able to remove its equipment, and said company moving its equipment shall send its bill for the same to Customer or Supplier may pay said bill and include the same in its bill to Customer; d) take any action needed to remove its equipment from the job site; e) act as stated herein at the expense of Customer and Customer hereby indemnifies and holds harmless Supplier from any harm arising from said actions, including, but not limited to, environmental harm, harm to the real property and personal property and harm to the real and personal property of any third party; and f) charge Customer interest on any unpaid balance at the lesser of: i) eighteen percent (18%) per annum, or ii) the maximum rate permitted by applicable law.
- 7) Taxes**
Customer shall be responsible for all customs fees, duties, and foreign, federal, state or local taxes (including, sales, use, excise or similar taxes and foreign withholding taxes).
- 8) Transportation**
For Equipment sold, Customer may arrange shipment and will pay all crating, handling and shipping costs. Risk of loss passes to Customer at the time Customer and/or any carrier takes possession of the Equipment from Supplier. For Equipment sold where Customer does not timely furnish shipping instructions or requests that Supplier arrange shipment, such transportation shall be in a commercially reasonable manner at Customer's risk and invoiced to Customer at current freight rates, plus all handling incurred, or at the prevailing mileage rate for any vehicles used by Supplier's personnel. Risk of loss will then pass to Customer at the time the Equipment leaves Supplier's premises, warehouse or store. All claims for shortages, damages, corrections or deductions must be made in writing within 10 days from receipt of goods and if shipper fails to comply, it waives its right to make a claim.
- 9) Consequential and Incidental Damages**
Supplier will not be responsible for consequential or incidental damages of any kind, which shall include, but not be limited to, loss of profits, use or business opportunity, damages for failure to meet deadlines, pollution damage and/or wreck or debris removal expense and Customer holds harmless and indemnifies Supplier from all harm arising from any claims made against Supplier from out of any of these things.
- 10) Force Majeure**
Supplier will not be liable for any damages, including special and consequential damages, as stated above, caused by events of force majeure or any other occurrences beyond Supplier's reasonable control subject to all of the limitations contained herein. In such event, the time for performance will be extended automatically for such reasonable time as is necessary to permit performance hereof.
- 11) Disclaimer of All Warranties Except Those Specifically Granted Herein Supplier hereby disclaims all warranties except those specifically granted and states as follows:**
 - a) Supplier makes no warranties of any kind regarding its equipment and/or services;
 - b) technical information and any assistance in equipment installation or technical or engineering information concerning equipment or services provided by Supplier will be advisory only, at Customer's sole cost and on an "as is" basis;
 - c) no warranty is given with respect to such services or information and Supplier will not be liable for any claims arising from its furnishing or Customer's use of such assistance or information;
 - d) Supplier specifically disclaims all implied warranties, the warranty of merchantability, warranty of fitness for a particular purpose and any warranty that the equipment or service provided by Supplier will actually accomplish the goal(s) desired by Customer. Supplier grants to Customer only a limited warranty as follows: Supplier grants only to Customer only a 1-year warranty on material and workmanship on its new products commencing at date of shipment.

12) Insurance

The parties agree that the indemnities provided by Customer to Supplier herein shall be supported either by available insurance or that Customer shall voluntarily become self-insured, in whole or part and upon request of Supplier prove that Customer is good for the loss and that Customer is sufficiently self insured. In addition, Customer shall, at its expense, maintain adequate insurance to fully protect any Equipment or Services or personnel supplied by Supplier and shall supply to Supplier, upon request, satisfactory evidence of sufficient insurance coverage to protect Supplier, Supplier's property, Supplier's personnel and Supplier's liability.

13) Prices

All Supplier's, terms, conditions, prices, rates and charges are subject to change without notice.

14) Assignment

Customer may not assign any rights or obligations hereunder, without Supplier's prior written consent.

15) Amendment of Indemnities to Conform to Law

The indemnities provided by Customer herein shall be limited to the extent necessary for compliance with applicable state and federal laws.

16) Termination/Cancellation

Unless provided otherwise in writing herein, Customer cannot terminate or cancel any order once Supplier has accepted the order. No termination shall relieve Customer of any liability incurred and Customer's obligations shall survive such termination, including all hold harmless and all indemnities and all warranties & non-warranties contained herein which are made expressly for the benefit of Supplier.

- Termination Policy: No goods or products supplied pursuant hereto maybe returned without Supplier's written permission. Supplier assumes no responsibility without Supplier's written permission. All returns shall be made freight prepaid. Supplier will charge to Customer a 25% Restocking Charge upon the return of goods by Customer.
- Special Orders: A special order is an order for any product of Supplier or which comes from Supplier's sources which is non standard requiring separate/additional manufacturing, engineering, modification, tooling and machining. If Supplier agrees in writing that a Special Order can be terminated, Special Orders cannot be cancelled unless Customer agrees in writing to pay for all work including engineering completed up to the time of cancellation.

17) Default

If Customer ever defaults on or breaches any Term or Condition contained herein or in any other document of Supplier mentioned above, all charges for all Equipment and Services provided by Supplier for Customer's benefit shall automatically accelerate and shall immediately become due and payable, notwithstanding any other provision which would afford Customer, under normal circumstances, any stated amount of time in which to pay for said charges. In addition, all discounts which may have been offered to Customer shall automatically and immediately be revoked and become fully due and owing with no action or notice from Supplier, notwithstanding any other provision to the contrary. If Customer ever disputes any charges of Supplier, Customer shall tender to Supplier all amounts for all charges which are not disputed by Customer. Customer hereby indemnifies and holds Supplier harmless for and agrees to reimburse Supplier for all costs of collections, including, but not limited to, actual attorney's fees and costs incurred in connection with the collection of past due amounts and defending against any counterclaims. Notwithstanding any other provision in this document or any other document or check, Customer agrees that all payments received by Supplier on Customer's account may be applied first to all outstanding interest and then to the oldest amounts owed by Customer to Supplier, and this provision is not waived by Supplier by accepting any check from Customer containing contrary language.

18) Customer Holds Harmless and Indemnifies Supplier

Customer shall hold harmless, defend, indemnify, release and hold Supplier harmless from and against any and all claims by Customer, Customer's customer, owner, or any other person or entity against Supplier of every kind or character, whatsoever, whether such claims are based on theories of contract law, tort law, or otherwise, direct or indirect, including incidental, special and consequential damages caused by Supplier arising out of delivery, pick-up, repair, use or operation of equipment or services relating to execution, completion or termination of this contract or on account of bodily injury or death or property damage, destruction or economic loss (including, but not limited to release of radioactive materials, contamination or damage to real property or personal property, land, buildings, vehicles, or property rights) because of purchase, delivery, installation, possession, operation, use, condition or return of goods, people, services and/or equipment used, purchased, or used during the term of this contract, or on account of infringement of any patent, design, copyright, or trade name or mark, whether by Supplier, Customer or otherwise, irrespective of whether Supplier was concurrently negligent or at fault for any such claims where the damage, injury or death was caused by the sole or partial negligence of Supplier.

19) Inspection

Customer's acceptance of delivery and signature of its representative on any delivery tickets or other Supplier documents is conclusive evidence that Customer found the Equipment to be suitable for its needs and in good condition and that the signor was the agent for Customer or Customer's Customer, building or land owner, contractor, sub contractor and operator. Customer also has a duty to inspect Equipment prior to use and to notify Supplier immediately of any defects and before use of the Supplier's product. SALE TERMS: The following are in addition to and a part of all other Terms and Conditions provided for herein.

20) Limited Liability/Disclaimer

- Supplier does warrant Equipment sold by Supplier to Customer to be free from defects in material or workmanship.
- In the event that a court finds that Supplier is liable for any breach of contract or any breach of warranty, Supplier's liability for said breach is expressly limited to the repair or replacement, at its sole option, of any Equipment which proves to be defective during any period declared by the court to be a period of warranty. All such Equipment shall be repaired or replaced F.O.B. Supplier's plant, warehouse, store or premises.
- In the event that a court finds that Supplier has an obligation to repair or replace equipment, said repair or replacement constitutes agreed and liquidated damages for any breach of Supplier's actual or court-declared warranty.
- The remedies stated above for any such breach thereof, shall be in lieu of all other

warranties, express or implied, including all other warranties for merchantability or fitness for any particular purpose which Supplier has specifically disclaimed herein, and in lieu of liability for Supplier's negligence or fault and Customer's rights and remedies under the Texas Deceptive Trade Practices Consumer Protection Act (chapter 17, Texas Business and Commerce Code).

21) Prices

- Prices for standard equipment will be the sales price shown on Supplier's current product sales price list ("Price List") or Price Book, F.O.B. Supplier's plant, warehouse, district stock points, or premises.
- Requests for quotations for nonstandard Equipment should be sent to the appropriate Supplier office. Quoted prices are valid for 30 days after the date of the quotation, unless otherwise noted on the quotation or unless canceled by Supplier prior to Customer's acceptance.
- Cost of additional labor, materials or outside services for modification of such procedures or specifications requested by Customer will be charged to Customer at Supplier's prevailing rate.
- Services required to install Equipment will be based on the prevailing rates at the time of installation.

22) Delivery/Disclaimer

- Supplier will use its best efforts to have Equipment ready for shipment, subject to receipt of all necessary Customer information, including approved drawings. HOWEVER, SUPPLIER ASSUMES NO LIABILITY FOR DAMAGES INCURRED AS A RESULT OF ITS LATE DELIVERY OF EQUIPMENT, SUPPLIES, PRODUCT, PERSONAL PROPERTY, REGARDLESS OF CAUSE.
- Title and risk of loss will pass to Customer upon delivery of Equipment, F.O.B. Supplier's plant, warehouse or premises.
- If unable to deliver, Supplier may charge Customer its customary storage rates and Customer will maintain all-risk property insurance on Equipment, at its replacement value. Supplier will not be liable for deterioration of Equipment, personal property, product resulting from atmospheric conditions, acts of God, or other events regardless of whether they are within Supplier's reasonable control while in Supplier's possession or in transit to Customer's destination or location.

Service Terms

The following are in addition to and a part of all other Terms and Conditions provided for herein.

1) Limited Liability/Disclaimer

- Supplier will use its best efforts to ensure that all personnel furnished are competent and that Equipment, supplies, personal property or product furnished is in good condition; however, Customer agrees that the Equipment and personnel come without warranty or guarantee of any kind whatsoever except as provided herein.
- Supplier's personnel will attempt to perform the work requested by Customer; however, because of the nature of the work to be accomplished and because of the unpredictable conditions which always exist, such results as required by Customer or Customer's Customer cannot be and are not guaranteed or warranted and Customer agrees that Supplier makes no warranties of any kind and that Supplier does not guarantee any particular result as from furnishing people, goods, product, personal property, equipment or services.
- Supplier reserves the right not to do work if, in its sole discretion, job conditions render such action inadvisable for any reason or unsafe for any reason.
- Customer agrees that any employee(s) furnished by Supplier shall not be responsible for any final decision made on any job. Rather, Customer shall retain complete control and supervision of the job, building site, project and performance of operations in and about the job site.
- Customer shall pay Supplier for Equipment and Services regardless of whether the desired results are achieved without any deduction or offset of any kind, irrespective of any Claims which Customer may assert or allege against Supplier or any Supplier and/or manufacturer of Equipment and/or Services, at the rates indicated in the Customer's document, manual, delivery documents or Price Book in effect at the time of delivery.
- Customer will be invoiced at the sales rate or service rates in effect at the beginning of the invoice period.
- Supplier makes no warranty or representation of any kind, express or implied, as to the quality, performance or function of its people, as to the design, operation, condition or quality of the material or workmanship of equipment or performance of equipment delivered to Customer, it being agreed that all such risks as between Supplier and Customer are to be borne by Customer, regardless of whether such equipment is operated under Supplier's supervision, and all equipment, services and people are accepted by Customer "as is" except as provided elsewhere herein. Customers desiring different standards than those contained herein should, at Customer's expense, obtain an inspection of goods, services, equipment and people prior to use and the benefits of any and all implied warranties of Supplier are hereby waived by Customer except as elsewhere provided herein.

2) Charges

All charges are on a daily basis for a 24-hour day or any part stated therein.

- Services
 - all Services are on a daily or hourly basis, subject to any minimum charge, all of which are specified by Supplier in Supplier's documents mentioned herein;
 - charges begin when each Service person departs Supplier's store location where said person or Equipment is based and the charges shall continue until returned to that store;
 - Customer shall furnish quarters and meals for Supplier's personnel or reimburse Supplier for reasonable living expenses incurred at the prevailing rate from the time each Service person leaves the Supplier's location until return to Supplier's location;
 - if personnel and/or Equipment are dispatched at Customer's request, but are later canceled, Customer will be invoiced for a "dead call" as provided in the Price Book or other Supplier documents mentioned herein.
- Standby Charges: Standby rates may be applied under conditions specified in the Price Book.

3) Trade Discount

Trade discounts, if any, apply only to Equipment, goods, or services which are paid for within 30 days of the invoice date. In the event payment is not timely made, with time being deemed to be of the absolute essence, all discounts granted are automatically revoked and reversed on Customer's account and are fully due and owing.



The Reliable Source

Manufacturer of

Newco

COOPER



QuadroSphere

www.newmansvalve.com

**Corporate Headquarters
Houston - Texas**

1300 Gazin St.
Houston, TX 77020
Tel: 713.675.8631
Fax: 713.675.1589
Toll Free: 800.231.3505

California

1539 Del Amo Blvd.
Carson, CA 90746
Tel: 310.667.8570
Fax: 310.878.0355

New Jersey

19A Cotters Lane
East Brunswick, NJ 08816
Tel: 732.257.0300
Fax: 732.238.0132

New Jersey Automation Branch

P.A.S.
9 Joanna Court
East Brunswick, NJ 088
Tel: 732.257.0300
Fax: 732.238.0132

Edmonton

9555 - 12 Ave. SW
Edmonton, AB T6X 0C6
Canada
Tel: 780.464.3500
Fax: 780.467.0376
Toll Free: 800.661.7326

Barrie

P.O. Box 881
92 Davidson St.
Barrie, Ontario L4M 4Y6
Canada
Tel: 705.737.4216
Fax: 705.737.5156
Toll Free: 800.461.4430

China

Suite 1003A, Jinying Tower A
No. 1518 Minsheng Road
Pudong, Shanghai CHINA 200135
Tel: ++ 86 21 6104 9569
Fax: ++ 86 21 6104 9579

**“Quality in Design”
“Durability in Construction”**

Toll Free: 800.231.3505