

GM 4-Cylinder Cam Tool Set

Operating Instructions

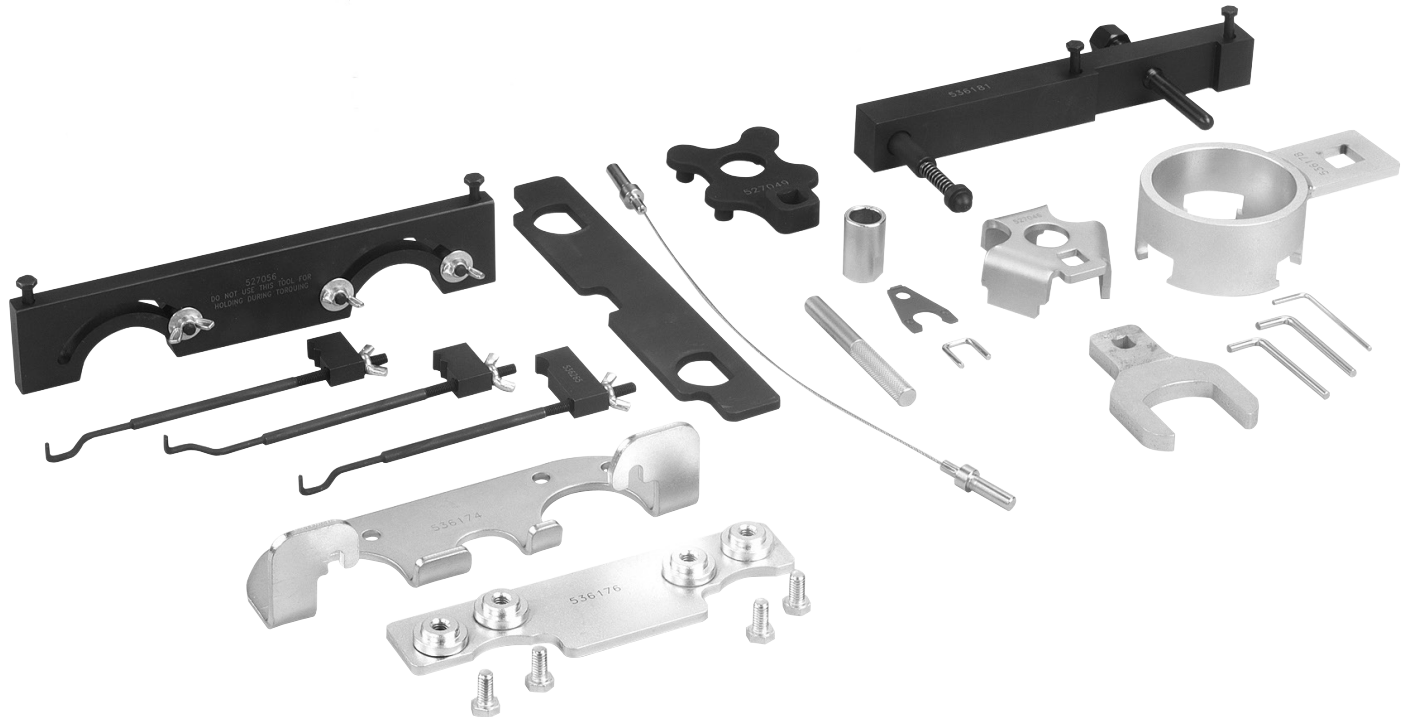

Cam Tool	Part No.	Page
Camshaft Gear Holder.....	536174.....	2
Camshaft Gear Holder.....	536176.....	2
Camshaft Holding Tool.....	536172.....	14
Camshaft Sprocket Holding Tool.....	536181.....	14
Camshaft Sprocket Holding Tool.....	527056.....	6
Camshaft Sprocket Wrench.....	527046.....	9
Camshaft Sprocket Wrench.....	527049.....	12
Camshaft Timing Alignment Pin.....	536254.....	3
Camshaft Timing Alignment Pins.....	527045.....	10
Crankshaft Pulley Holder	536178.....	5
Timing Belt Adjuster.....	536173.....	1
Timing Chain Holder.....	536186.....	8
Timing Chain Holder.....	536187.....	8
Timing Chain Holder.....	536265.....	15
Timing Chain Tensioner Loading Tool.....	527061-1	7
Timing Chain Tensioner Loading Tool.....	527061-2	7
Timing Chain Tensioner Retainer	535255.....	4
Timing Chain Tensioner Retainer	532195.....	11
Timing Chain Tensioner and Shoe Retainer	532174.....	13

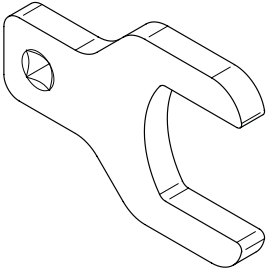

No. 536173 Timing Belt Adjuster

Application: 1.6L 4-cylinder engine used in
2004-2007 Chevrolet Aveo

1. Loosen the water pump retaining bolts.
2. Using the timing belt adjuster No. 536173, rotate the water pump counterclockwise (CCW) to loosen the timing belt or clockwise (CW) to tighten the timing belt.
3. Rotate the water pump clockwise (CW) until the adjusting arm pointer of the timing belt automatic tensioner is aligned to the notch in the timing belt automatic tension bracket. See Figure 2.
4. Tighten the water pump bolts.

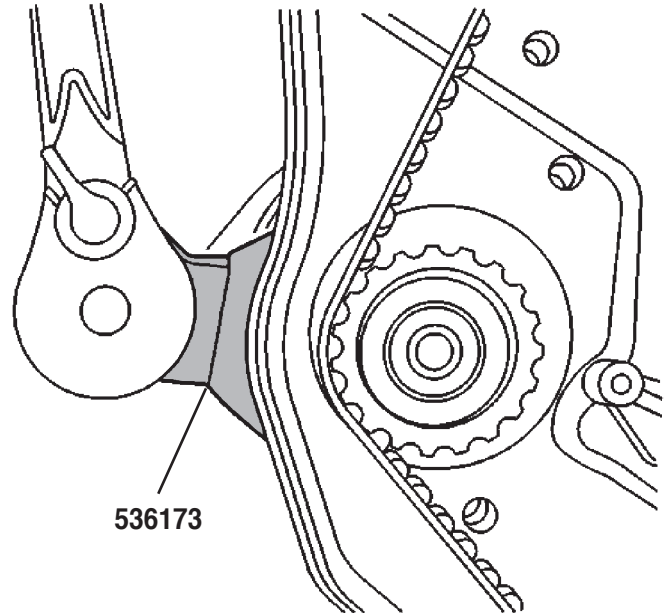

Figure 1

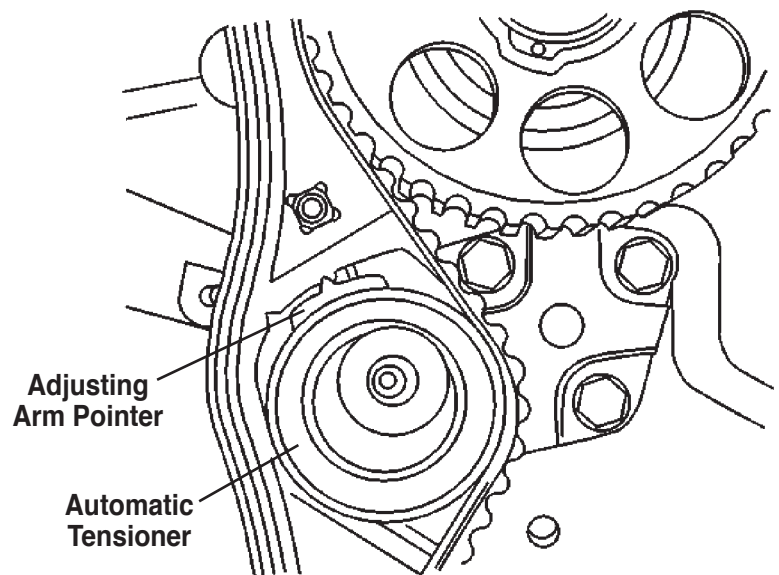
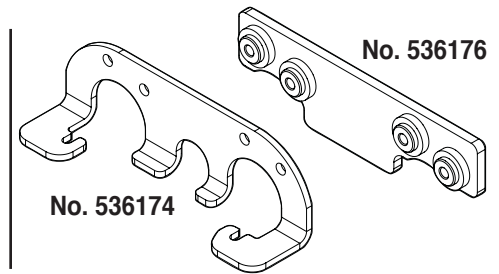

Figure 2

No. 536174 & 536176 Camshaft Gear Holders

Applications: 1.9L DOHC 4-cylinder VIN 7 engine used in
2000-2002 Saturn SC-2, SL-2, SW-2



NOTE: No. 536174 & No. 536176 camshaft gear holders must be used together. No. 536174 mounts on the front of the cam gear. No. 536176 mounts on the rear of the gear.

1. Remove both front camshaft bearing caps.
2. Assemble No. 536176 camshaft gear holder to the back side of the camshaft gears.
3. Assemble No. 536174 camshaft gear holder to the cam gears and No. 536176 with four (4) bolts. Torque the bolts to 19 ft. lbs. (25 N•m).

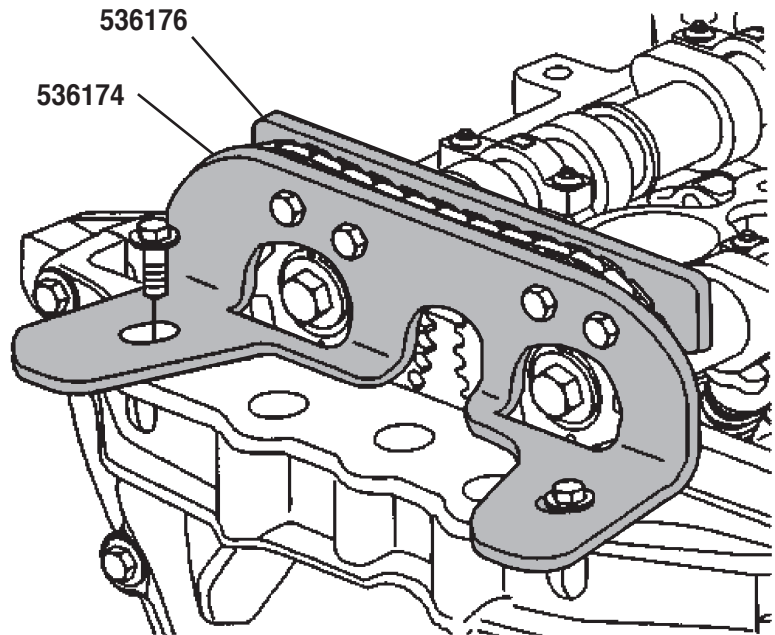

Figure 1

4. Install and tighten two (2) bolts that attach the No. 536174 camshaft gear holder to the engine front cover.
5. While holding each camshaft in place with a 24 mm open end wrench, carefully remove the camshaft timing gear retaining bolts and washers. See Figure 2.

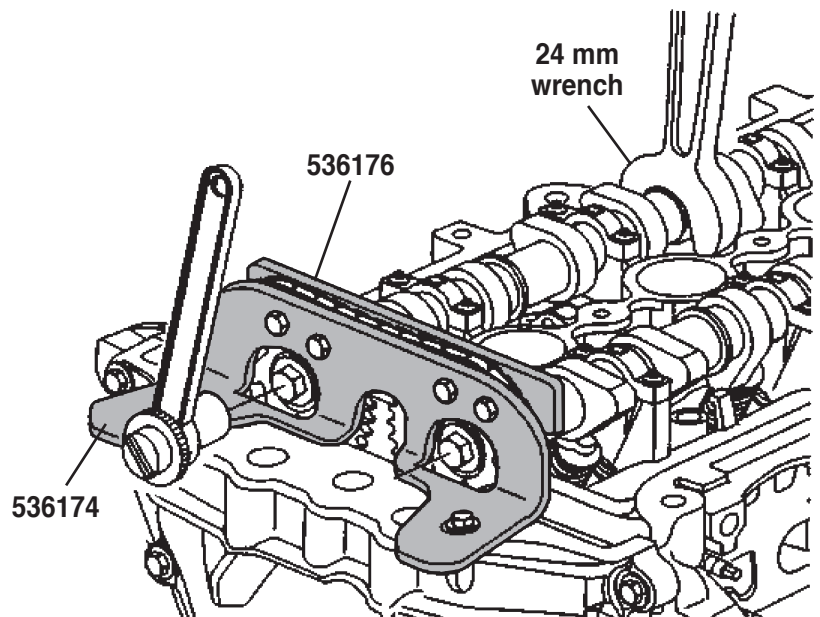
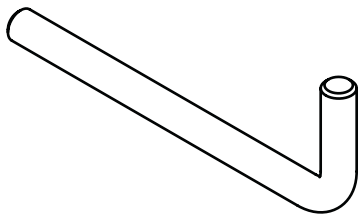

Figure 2

6. Loosen and remove the remaining camshaft bearing caps. Slide the camshaft rearward to remove from the timing gears.



No. 536254 Camshaft Timing Alignment Pin

Applications: 1.9L VIN 7 4-cylinder engine used in
1991-2002 Saturn SC-2, SL-2, SW-2.
1.9L VIN 8 4-cylinder engine used in
1995-2002 Saturn SC-1, SL-1, SW-2

**NOTE: For 1.9L VIN 8 engines, one (1) No. 536254 pin is required.
For 1.9L VIN 7 engines, two (2) No. 536254 pins are required.**

1. Bring the camshaft(s) up to TDC #1 cylinder. Verify TDC by installing No. 536254 camshaft timing alignment pin(s) through the hole(s) in the cam sprocket and into the hole(s) in the cylinder head.
2. Install the timing chain onto the cam gear.
3. Remove the No. 536254 camshaft timing alignment pin(s).

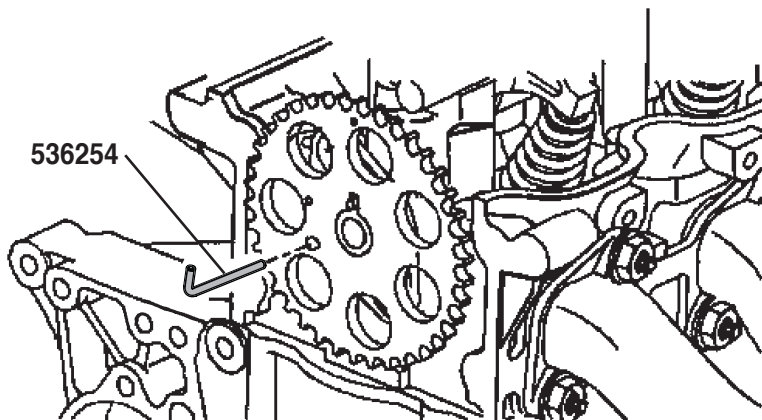

1.9L VIN 8 Engine
Figure 1

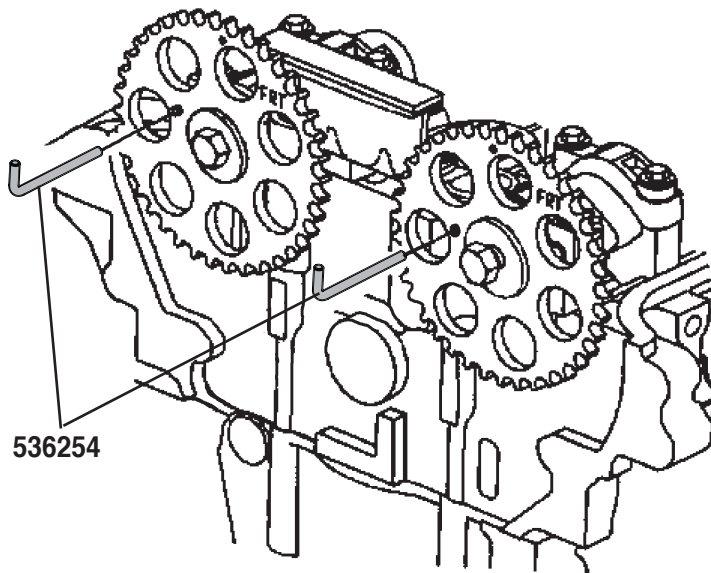

1.9L VIN 7 Engine
Figure 2

 **CAUTION:** To prevent personal injury, wear eye protection that meets ANSI Z87.1 and OSHA standards.

No. 536255 Timing Chain Tensioner Retainer

Applications: 1.9L VIN 7 4-cylinder engine used in
1991-2002 Saturn SC-2, SL-2, SW-2

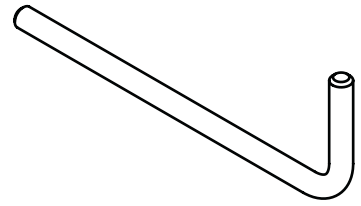

1. Retract the timing chain tensioner plunger, and pin the ratchet lever with the No. 536255 timing chain tensioner retainer.
2. Install the chain tensioner and torque the retaining bolts. Refer to the vehicle manufacturer service manual for torque specifications.
3. Remove No. 536255 timing chain tensioner retainer, and allow the tensioner plunger to extend.

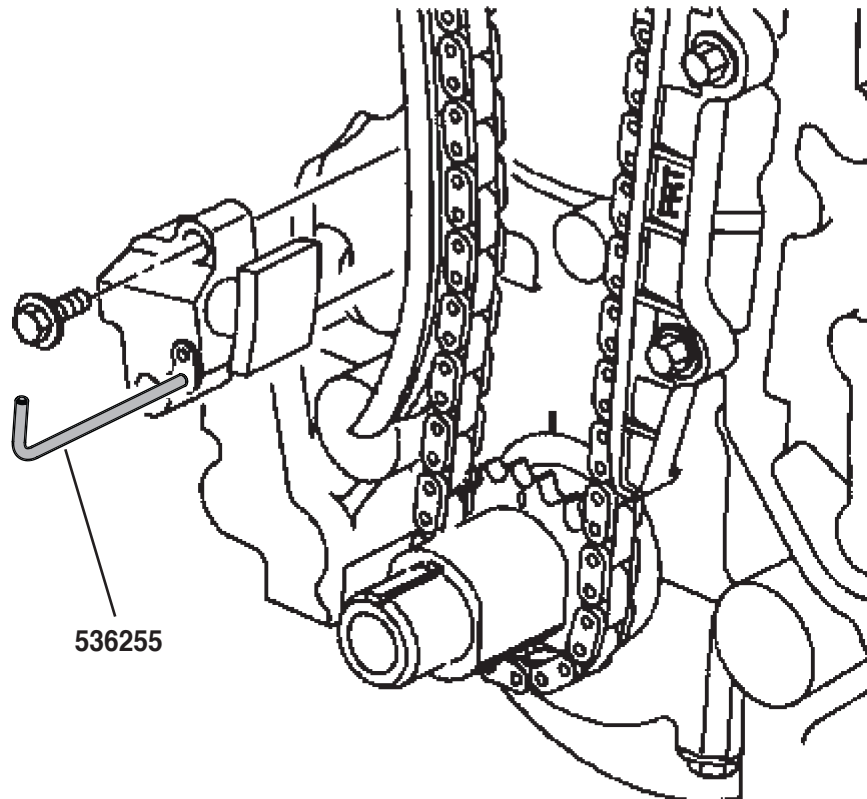
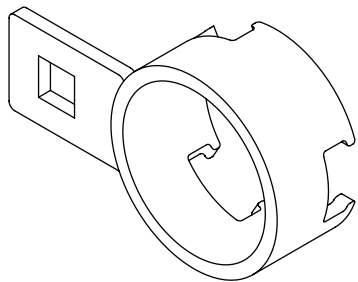

Figure 1



No. 536178 Crankshaft Pulley Holder

Applications: 2.0L DOHC VIN P engine used in 2005-2007 Chevrolet Cobalt

2.2 DOHC VIN F engine used in 2003-2007 Chevrolet Malibu, 2002-2005 Cavalier, 2002-2004 Olds Alero, 2002-2005 Pontiac Grand Am and Sunfire, 2000-2005 Saturn L Series, 2002-2007 Saturn Vue, 2005-2007 Chevrolet Cobalt

2.4 DOHC VIN B engine used in 2005-2007 Chevrolet Cobalt, 2006-2007 Chevrolet HHR, 2006-2007 Pontiac G6, Pursuit, and Solstice

2.4 DOHC VIN T engine used in 1996-2002 Chev Cavalier, 1999-2001 Olds Alero, 1996-1998 Olds Achieva, 1996-2002 Pontiac Grand Am and Sunfire, 1996-1998 Buick Skylark

1. Position No. 536178 crankshaft pulley holder over the crankshaft pulley.
2. Attach a breaker bar or ratchet to the handle of No. 536178 to hold the crankshaft pulley while loosening the crankshaft bolt.

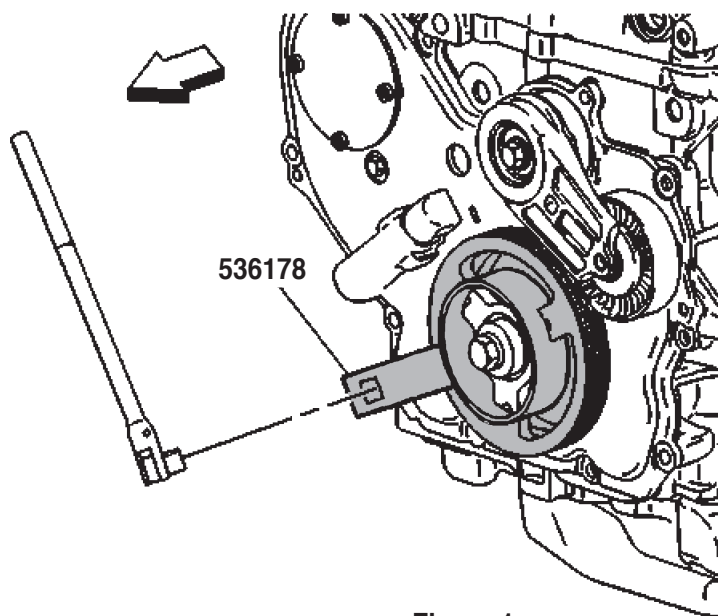

Figure 1

No. 527056

Camshaft Sprocket Holding Tool

Application: 2.0L VIN P 4-cylinder engine used in
2005-2007 Chevrolet Cobalt

2.2L DOHC VIN F 4-cylinder engine used in
2002-2004 Olds Alero, 2002-2005 Pontiac Sunfire & Grand Am
2000-2005 Saturn L Series, 2002-2007 Saturn Vue,
2003-2007 Saturn Ion, 2002-2005 Chevrolet Cavalier,
2002-2007 Chevrolet Malibu, 2005-2007 Chevrolet Cobalt

2.4L DOHC VIN B 4-cylinder engine used in
2005-2007 Chevrolet Cobalt and HHR,
2005-2007 Pontiac G6, Pursuit, and Solstice

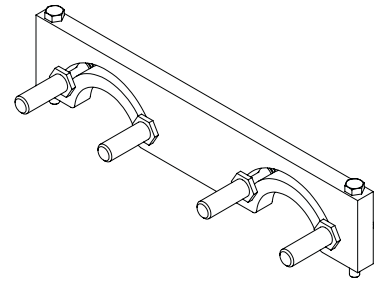

No. 527056 camshaft sprocket holding tool is used to hold the cam sprockets and chain in time when servicing the camshafts of valve components.

1. Remove the upper timing chain guide. See Figure 1.
2. Install No. 527056 camshaft sprocket holding tool. See Figure 2.
3. Remove the intake and exhaust camshaft sprockets bolts. Slide the camshaft sprocket and timing chain forward to clear the camshaft. See Figure 3.

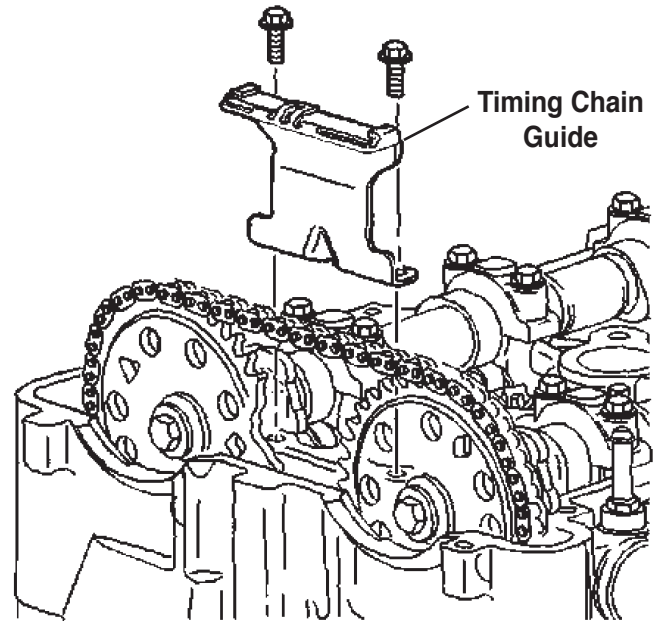
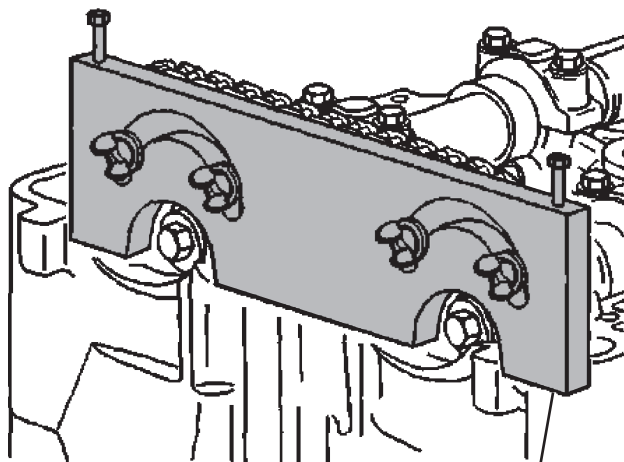
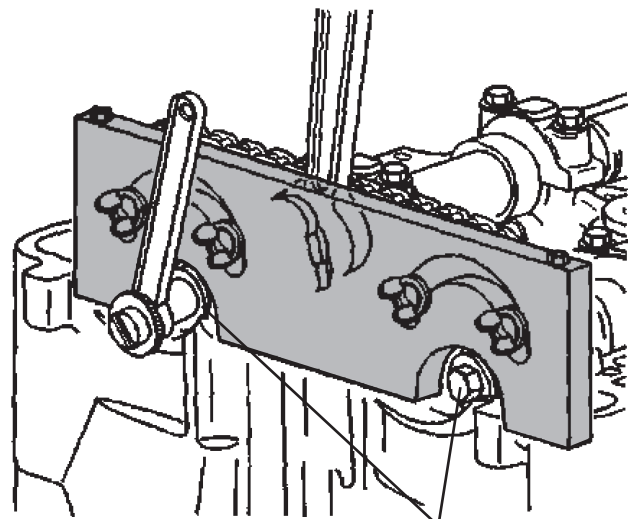

Figure 1



527056

Figure 2



Camshaft
Sprocket Bolts

Figure 3

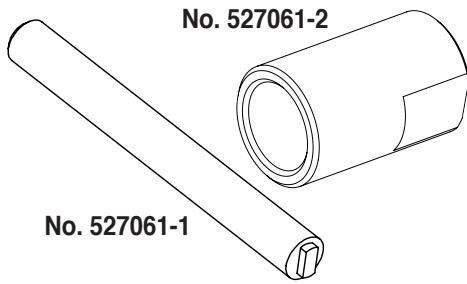

No. 527061-1 & 527061-2 Timing Chain Tensioner Loading Tools

Applications: 2.0L VIN P 4-cylinder engine used in
2005-2007 Chevrolet Cobalt

2.2L DOHC VIN F 4-cylinder engine used in
2002-2005 Chev Cavalier, 2003-2007 Chev Malibu,
2004-2005 Chev Classic, 2005-2007 Chev Cobalt,
2002-2004 Olds Alero, 2002-2005 Pontiac Sunfire
and Grand Am, 2000-2005 Saturn L Series,
2002-2007 Saturn Vue, 2003-2007 Saturn ION

2.4L VIN B 4-cylinder engine used in
2005-2007 Chevrolet Cobalt and HHR,
2005-2007 Pontiac G6, Solstice, and Pursuit

NOTE: No. 527061-1 and No. 527061-2 timing chain tensioner loading tools must be used together.

1. Remove the piston assembly from the body of the timing chain tensioner by pulling it out. See Figure 1.
2. Install the No. 527061-2 into a vise. See Figure 2.
3. Install the piston assembly into No. 527061-2. See Figure 2.
4. Using No. 527061-1, turn the ratchet cylinder into the piston assembly. See Figure 2.

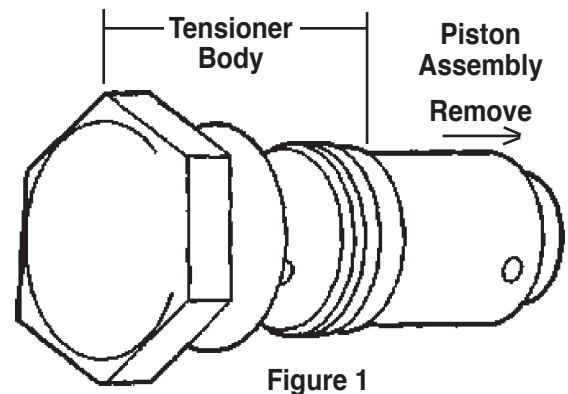

Figure 1

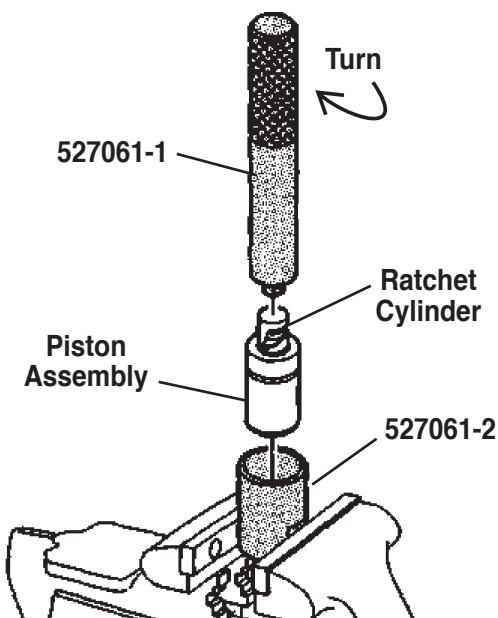

Figure 2

5. Install the compressed piston assembly back into the timing chain tensioner body until it stops at the bottom of the bore. See Figure 3. **Note: Do not compress the piston assembly against the bottom of the bore. This will activate the tensioner, which will then need to be reset.**
6. Measure the tension from end to end. It should measure approximately 72 mm (2.83 inches). If it measures more than this, the ratchet cylinder in the piston assembly is not fully compressed. Steps 2, 3, & 4 must be repeated until the tension measures correctly.

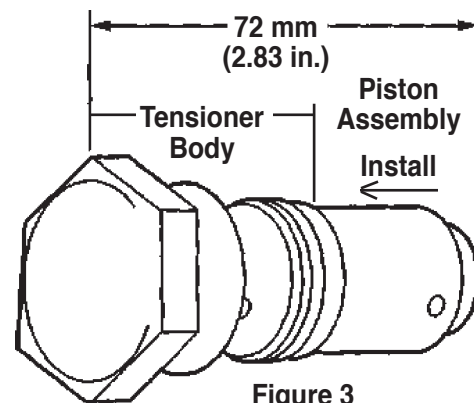



Figure 3

 **CAUTION: To prevent personal injury, wear eye protection that meets ANSI Z87.1 and OSHA standards.**

No. 536186 & No. 536187 Timing Chain Holders

Applications: 2.0L VIN P 4-cylinder engine used in
2005-2007 Chevrolet Cobalt

2.2L DOHC VIN F 4-cylinder engine used in
2002-2005 Chev Cavalier, 2003-2007 Chev Malibu,
2004-2005 Chev Classic, 2005-2007 Chev Cobalt,
2002-2004 Olds Alero, 2002-2005 Pontiac Sunfire
and Grand Am, 2000-2005 Saturn L Series,
2002-2007 Saturn Vue, 2003-2007 Saturn ION

2.4L VIN B 4-cylinder engine used in
2005-2007 Chevrolet Cobalt,
2005-2007 Pontiac G6, Solstice, and Pursuit

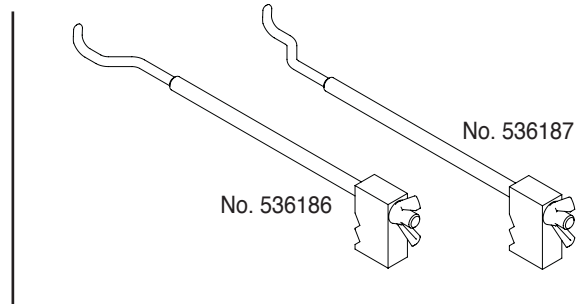

1. To retain the timing chain, install No. 526187 on the exhaust camshaft side of the timing chain assembly (see Figure 1). Hand-tighten the nut firmly.
2. To retain the timing chain, install No. 526186 on the intake camshaft side of the timing chain assembly (see Figure 2). Hand-tighten the nut firmly.

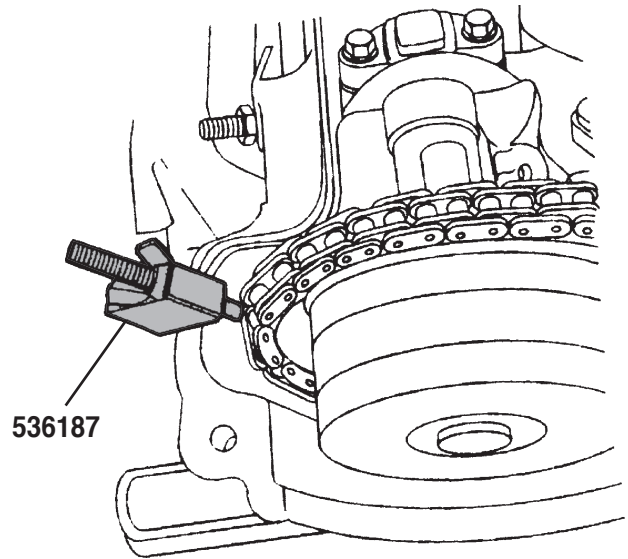

Figure 1

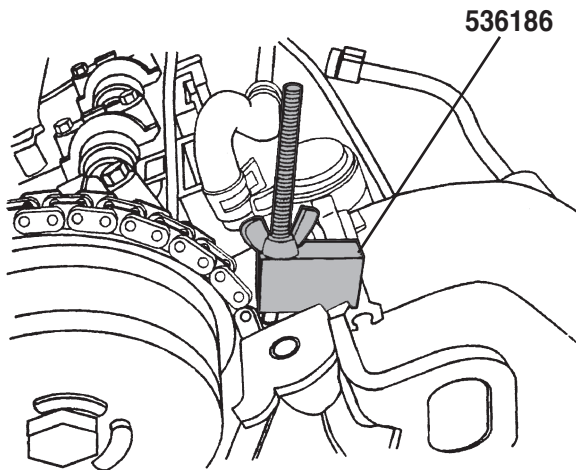
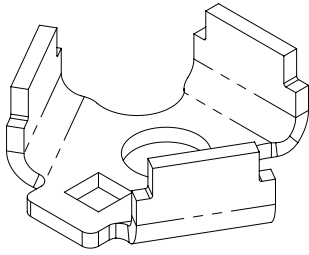

Figure 2



No. 527046 Camshaft Sprocket Wrench

Applications: 2.3L 4-cylinder engine used in
1988-1995 Buick Skylark, 1987-1991 Olds Calais,
1990-1991 Olds Cutlass Supreme,
1992-1995 Olds Achieva,
1988-1995 Pontiac Grand Am,
1995 Pontiac Sunfire

1. No. 527046 camshaft sprocket wrench is placed in the large holes of the cam sprocket, and used to rotate the camshaft or hold the cam sprocket in place when tightening or loosening the cam sprocket bolt.

No. 527045

Camshaft Timing Alignment Pins

Application: 2.3L & 2.4L 4-cylinder engine used in
1988-1998 Buick Skylark, 1996-2002 Chevrolet Cavalier,
1987-1991 Olds Calais, 1990-1991 Olds Cutlass Supreme,
1992-1998 Olds Achieva, 1999-2001 Olds Alero,
1988-2001 Pontiac Grand Am, 1995-2002 Pontiac Sunfire

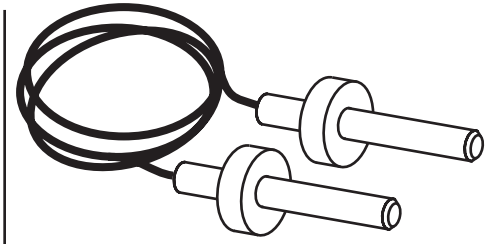

NOTE: No. 527045 Camshaft Timing Alignment Pins are used with the camshaft sprocket wrenches: No. 527046 (for 2.3 engines) and 527049 (for 2.4 engines).

1. Turn the crankshaft clockwise (CW) (as viewed from the front of the engine) until the mark on the crankshaft sprocket lines up with the mark on the cylinder block. The crankshaft sprocket keyway should point upward. This is Top Dead Center (TDC).
2. Turn the crankshaft clockwise (CW) 90° past TDC. This allows you to turn the camshaft without the valves hitting the top of the piston.
3. Using the camshaft sprocket wrench (527046 for 2.3 engines and 527049 for 2.4 engines), rotate the camshaft until the hole in the cam sprocket lines up with the hole in the timing chain cover. Install the 527045 camshaft timing alignment pin. Repeat this procedure on the DOHC engine.
4. Turn the crankshaft counterclockwise (CCW) 90° to line up the timing mark on the crank gear to the mark on the cylinder block.
5. Install the timing chain on the exhaust cam (except SOHC engine), then on the water pump drive sprocket and the crank sprocket.
6. On DOHC engines, remove the 527045 pins from the intake camshaft alignment hole using the 527046 sprocket wrench (for 2.3 engines) or the 527049 sprocket wrench (for 2.4 engines). Rotate the intake camshaft counterclockwise (CCW) enough to slide the timing chain onto the intake cam. Release the camshaft sprocket wrench. The chain between the two cam sprockets will tighten. If the intake cam is accurately timed, the 527045 alignment pin will slide into the alignment hole on the cam gear and into the hole in the timing chain cover. If the alignment pins do not slide into both holes, the intake cam is out of time and the procedure must be repeated.

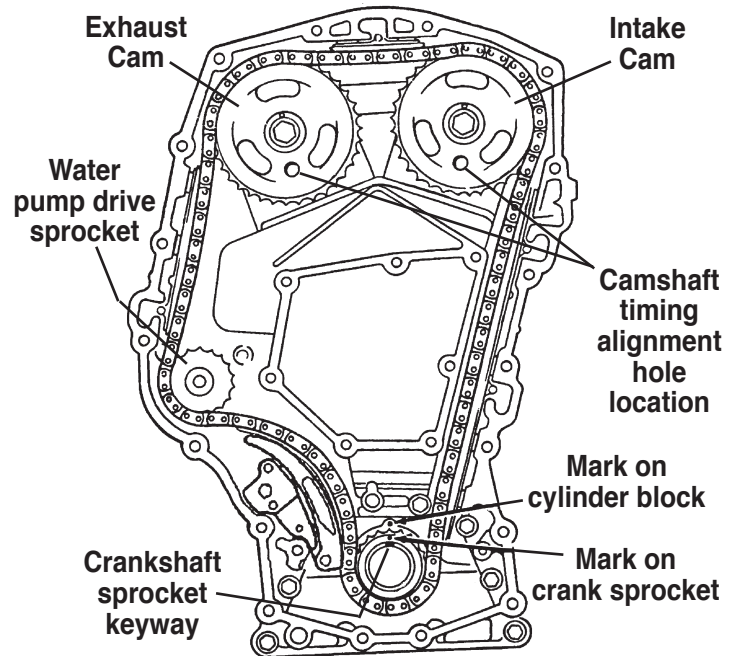

Figure 1 (DOHC Engine)

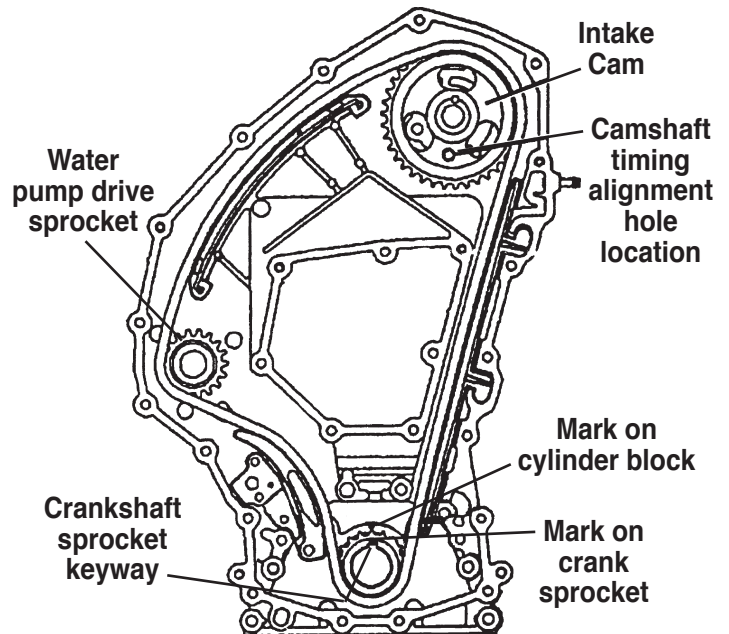

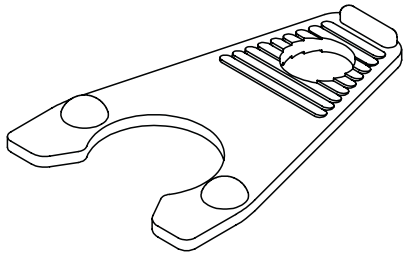

Figure 2 (SOHC Engine)

 **CAUTION:** To prevent personal injury, wear eye protection that meets ANSI Z87.1 and OSHA standards.



No. 532195

Timing Chain Tensioner Retainer

Applications: 2.3L 4-cylinder engine used in
 1988-1995 Buick Skylark, 1987-1991 Olds Calais,
 1990-1991 Cutlass Supreme,
 1992-1995 Olds Achieva,
 1988-1995 Pontiac Grand Am, 1995 Pontiac Sunfire

1. Refer to the vehicle service manual for procedures to install the timing chain and set the camshaft and crankshaft timing.
2. Position the restraint cylinder, spring, and nylon plug into the plunger. Align slot in restraint cylinder with peg in plunger assembly. Rotate the restraint cylinder in clockwise (CW) direction and push into plunger assembly until it is bottomed. Keep rotating the restraint cylinder clockwise until the spring force pushes the restraint cylinder away from the plunger. The plunger peg will lock the restraint cylinder in the loaded position.
3. Position No. 532195 timing chain tensioner retainer on the plunger assembly.
4. Position the loaded plunger assembly into tensioner body with the long end of the plunger toward the crankshaft.
5. Install the timing chain tensioner assembly with the long end of the plunger toward the crankshaft. Tighten to the vehicle service manual specifications.
6. Install the timing chain tensioner shoe and retainer.
7. Remove No. 532195 from the timing chain tensioner. Press the timing chain tensioner plunger into the tensioner body to unload the plunger.

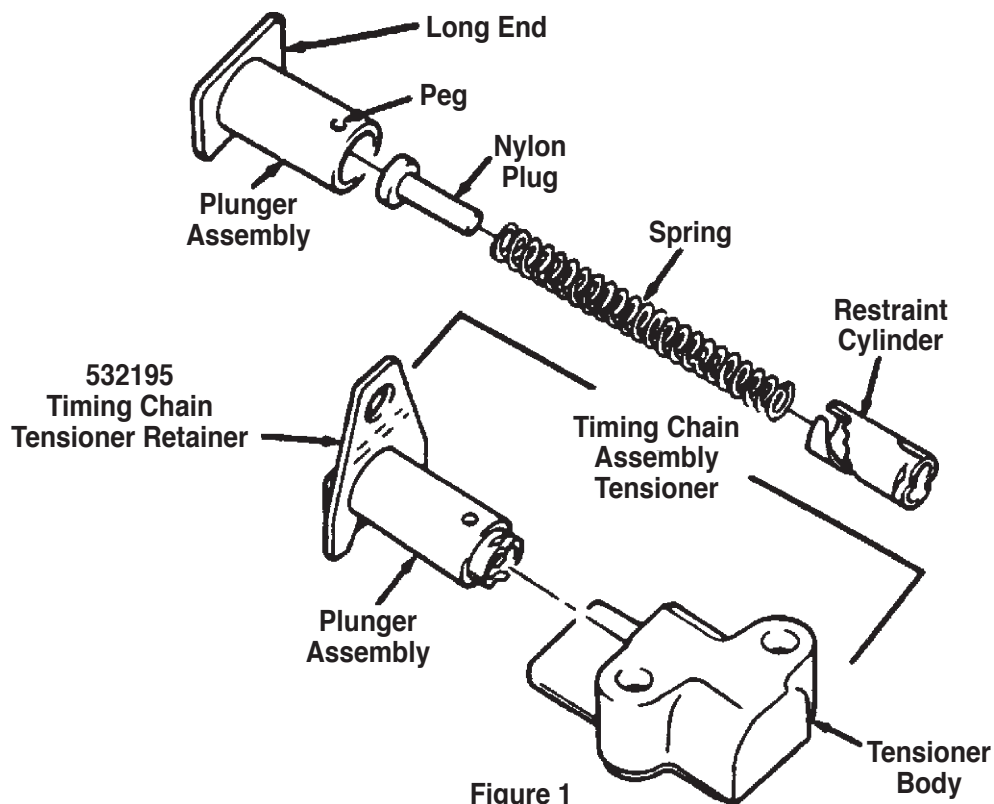

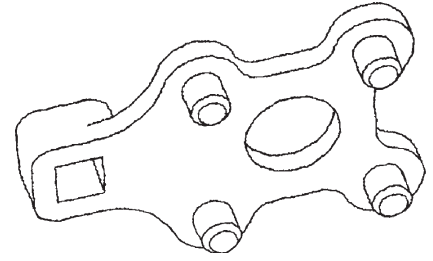

Figure 1

 **CAUTION:** To prevent personal injury, wear eye protection that meets ANSI Z87.1 and OSHA standards.

No. 527049 Camshaft Sprocket Wrench

Applications: 2.4L 4-cylinder engine used in
1996-1998 Buick Skylark, 1996-2002 Chevrolet Cavalier,
1996-1998 Olds Achieva, 1999-2001 Olds Alero,
1996-2001 Pontiac Grand Am,
1996-2002 Pontiac Sunfire



1. No. 527046 camshaft sprocket wrench is placed in the large holes of the cam sprocket, and used to rotate the camshaft or hold the cam sprocket in place when tightening or loosening the cam sprocket bolt.

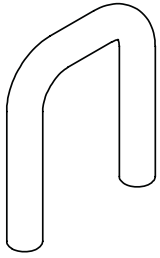

No. 532174 Timing Chain Tensioner and Shoe Retainer

Applications: 2.4L 4-cylinder engine used in
1996-1998 Buick Skylark, 1996-2002 Chev Cavalier,
1996-1998 Olds Achieva, 1999-2001 Olds Alero,
1996-2001 Pontiac Grand Am, 1996-2002 Pontiac Sunfire

1. Refer to the vehicle service manual for procedures to install the timing chain and set the camshaft and crankshaft timing.
2. Apply a light force on the tensioner shoe to compress the plunger.
3. Install a small screwdriver or pick into the reset access hole to pry the ratchet pawl away from the plunger and push the shoe to the tensioner body. Remove the screwdriver or pick.

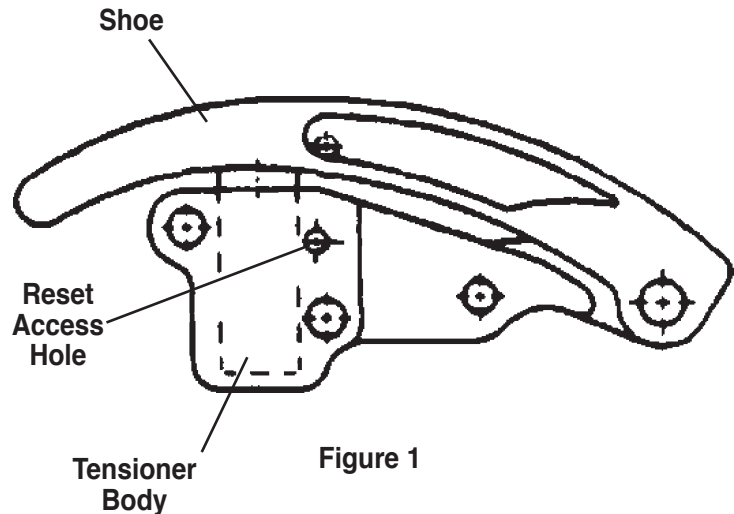

4. Install No. 532174 between the reset access hole and the hole in the shoe.
5. Install the loaded tensioner and shoe assembly into the engine, and tighten the retaining bolt to the service manual specifications. Remove No. 532174 to allow the tensioner to tighten the timing chain.

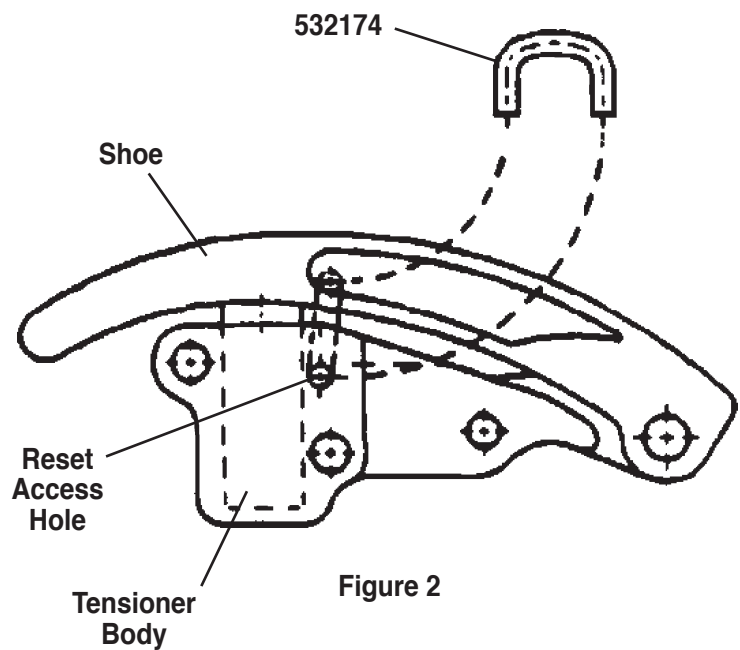

No. 536181 Camshaft Sprocket Holding Tool

No. 536172 Camshaft Holding Tool

Application: 2.8L 4-cylinder engine used in
2004-2007 Chevrolet Colorado and GMC Canyon

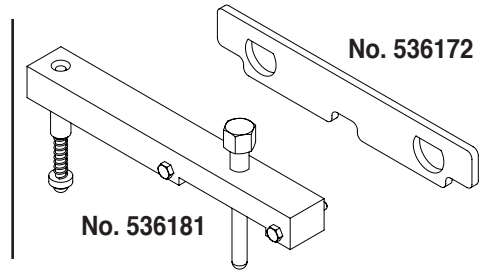

1. Rotate the crankshaft clockwise (CW) until #1 piston is on Top Dead Center (TDC) on the compression stroke.

2. Install No. 536172 camshaft holding tool to the rear of the camshaft. See Figure 1.

3. Remove the intake and exhaust camshaft sprocket bolts.

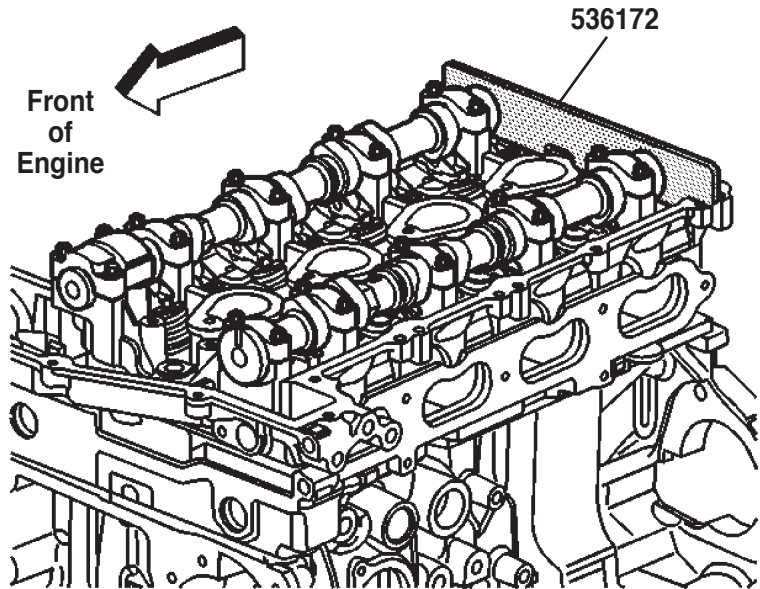

Figure 1

4. To maintain chain tension, install No. 536181 camshaft sprocket holding tool onto the cylinder head, and adjust the horizontal bolts into the camshaft sprockets. See Figure 2.

5. Carefully slide the sprockets (with the timing chain) from the camshaft to the No. 536181 camshaft sprocket holding tool.

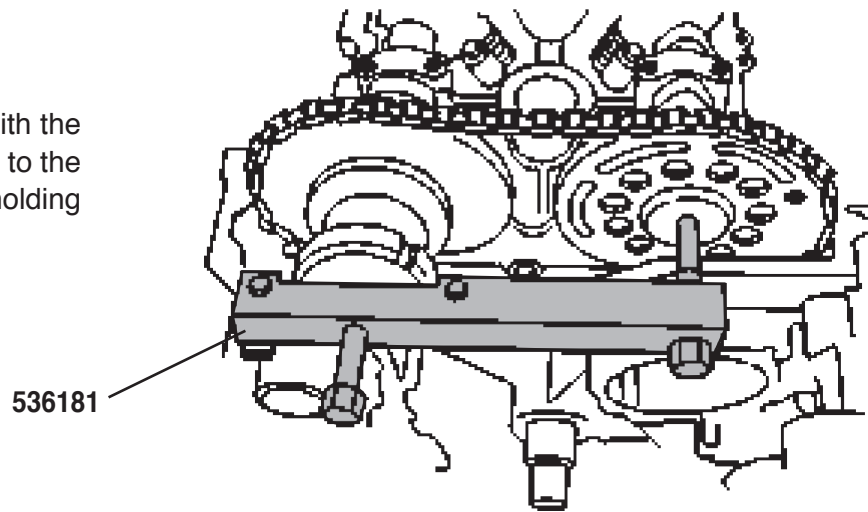
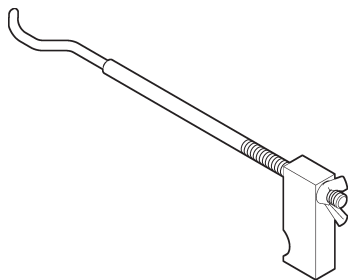

Figure 2



No. 536265 Timing Chain Holder

Applications: 2.8L 4-cylinder engine used in
2004-2007 Chevrolet Colorado and GMC Canyon

1. To retain the timing chain, install No. 536265 timing chain holder to the timing chain. Hand-tighten the nut on No. 536265 firmly.

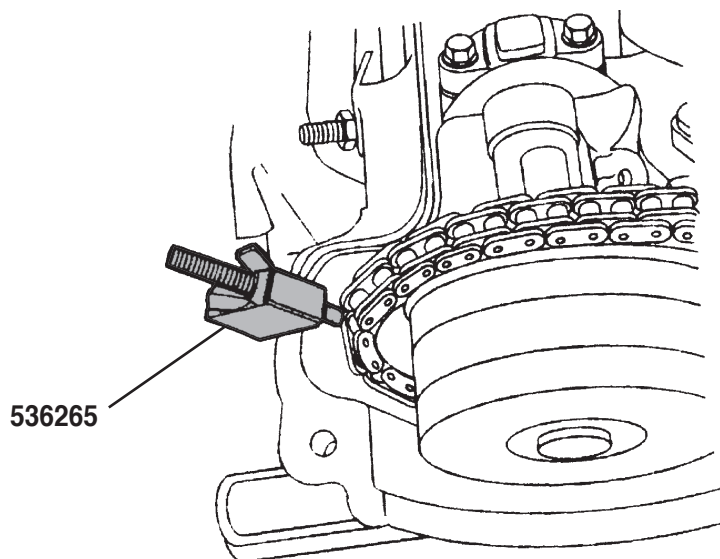

Figure 1