



GM NRRB: 2015

GREEN MARK FOR NON-RESIDENTIAL BUILDINGS NRB: 2015
including Hawker Centres, Healthcare Facilities, Laboratory Buildings and Schools

Technical Guide and Requirements

CONTENTS

Green Mark NRB: 2015 Technical Guide and Requirements

Table of Contents

About This Document.....	5
Design Stage and Verification Requirements.....	6
Energy Modeling Requirements	7
1. Climatic Responsive Design	7
P.1 Envelope and Roof Thermal Transfer.....	7
P.2 Air Tightness and Leakage	9
P.3 Bicycle Parking	9
1.1 Leadership	9
1.2 Urban Harmony.....	13
1.3 Tropicality.....	21
2. Building Energy Performance	31
P.4 Air Conditioning Total System and Component Efficiency.....	31
P.5 Lighting Efficiency and Controls.....	39
P.6 Vertical Transportation Efficiency.....	39
2.1 Energy Efficiency.....	40
Option 1: Energy Performance Points Calculator	40
2.1a Air Conditioning Total System Efficiency	40
2.1b Lighting System Efficiency	46
2.1c Carpark System Efficiency.....	47
2.1d Receptacle Load Efficiency	49
2.1e Building Energy	50
Option 2: Performance-Based Computation	51
2.1f Space Conditioning Performance.....	51
2.1g Lighting System Efficiency	52
2.1h Building Systems Performance	53
2.2 Renewable Energy	55
2.2a Solar Energy Feasibility Study.....	55
2.2b Solar Ready Roof	56
2.2c Adoption of Renewable Energy	57

3. Resource Stewardship	58
P.7 Water Efficient Fittings.....	58
3.1 Water.....	59
3.1a Water Efficient Systems	59
Better Water Efficient Fittings (Advanced Green Effort)	61
3.1b Water Usage Monitoring.....	62
3.1c Alternative Water Sources	64
3.2 Materials.....	64
3.2a Sustainable Construction	64
Use of BIM to Calculate CUI (Advanced Green Efforts).....	67
Use of Advanced Green Materials (Advanced Green Effort).....	70
3.2b Embodied Carbon	70
3.2c Sustainable Products	71
Sustainable Products with Higher Environmental Credentials (Advanced Green Effort).....	78
3.3 Waste.....	79
3.3a Environmental Construction Management Plan.....	79
3.3b Operational Waste Management.....	80
4. Smart and Healthy Building	81
P.8 Thermal Comfort	81
P.9 Minimum Ventilation Rate.....	81
P.10 Filtration Media for Times of Pollution	82
P.11 Low Volatile Organic Compound (VOC) Paints	82
P.12 Refrigerants.....	82
P.13 Sound Level	83
P.14 Permanent Instrumentation for the Measurement and Verification of Water-Cooled Chilled Water Plants.....	83
P.15 Electrical Sub-Metering & BMS	85
4.1 Indoor Air Quality	86
4.1a Occupant Comfort	86
4.1b Outdoor Air.....	88
4.1c Indoor Contaminants.....	89
4.2 Spatial Quality	91
4.2a Lighting	91
4.2b Acoustics	93

4.2c Wellbeing.....	96
4.3 Smart Building Operations	97
4.3a Energy Monitoring	97
Permanent M&V for VRF Systems (Advanced Green Effort).....	98
Permanent M&V for Hot Water Systems (Advanced Green Effort)	98
4.3b Demand Control.....	99
4.3c Integration and Analytics.....	101
4.3d System Handover and Documentation.....	103
Expanded Post Occupancy Performance Verification by a 3rd Party (Advanced Green Effort) .	103
4.3d Energy Performance Contracting (Advanced Green Effort)	104
5. Advanced Green Efforts.....	105
5.1 Enhanced Performance.....	105
5.2 Demonstrating Cost Effective Design	105
5.3 Complementary Certifications.....	106
5.4 Social Benefits	106
Annex 1: Energy Efficiency & Other Green Features [Hawker Centres]	107
Annex 2: Energy Efficiency & Other Green Features [Healthcare]	111
Annex 3: Energy Efficiency & Other Green Features [Laboratories Buildings].....	118
Annex 4: Energy Efficiency & Other Green Features [Schools].....	123
Annex A: Computational Fluid Dynamics Simulation Methodology and Requirements	127
Annex B: Effective Daylighting Simulation and Pre-Simulated Daylight Availability Tables Methodology and Requirements.....	141
Annex B2: Pre-Simulated Daylight Autonomy Tables.....	151
Annex C: Energy Modeling Methodology and Requirements.....	161

About This Document

The intent of this Document is to supplement the BCA Green Mark for Non-Residential Buildings: 2015 Criteria. Together, they spell out in entirety the detailed requirements for assessing and verifying the environmental performance of a building development. This Document contains relevant accompanying Definitions, Guidance Notes, Documentation Requirements, Worked Examples, as well as Annexes that are to be read in conjunction with the Intent, Scope, Assessment and References sections within the GM NRB: 2015 Criteria. Projects targeting Green Mark certification shall adhere to the relevant Design Stage and Verification requirements (where applicable) spelt out in this Document.

This Document is not intended to abridge safety, health, environmental or related requirements contained in other applicable laws, codes or policies administered by relevant authorities. Where there is a conflict between the requirements spelt out and such other laws affecting the design and construction of the building, precedence shall be determined by the relevant authorities.

If you need clarification on any aspect of this document, please contact the Building and Construction Authority, Singapore.

Green Mark NRB: 2015 Technical Guide and Requirements Revision Log

Revision	Description	Effective Date
R0	Version for Implementation	2 Nov 2016
R1	Revised Version to include annexes for specific building types Hawker Centres, Healthcare Facilities, Laboratory Buildings, and Schools. Alternate option for scoring of Energy related items and other minor changes.	1 Aug 2018
	Revision 3.1: Minor amendments made on 1 Nov 2019.	

Copyright © 2016 by Building and Construction Authority.

All rights reserved. This document may be used by individuals for reference purposes only.

Design Stage and Verification Requirements

During the design stage, when the building has not yet been constructed/ completed construction, the project targeting Green Mark certification shall demonstrate that the project meets the intents of the criteria and target certification level, as well as the relevant prerequisite requirements. Aside from the Green Mark Assessment which is to be conducted, the documentation requirements as per stipulated in this Document shall also be submitted to BCA through the [GM Online](#).

Upon a Green Mark project's completion, a verification audit shall be carried out as follows:

- Verification Stage 1:** The project shall demonstrate the functionality and performance of its green features which resulted in the Green Mark certification, and demonstrate compliance with the committed design specifications through documentary evidences and a site verification audit. The relevant documentary evidences for Verification Stage 1 are reflected in this Document under *Documentation Requirements* parked within the respective criteria sections. The documents shall be submitted through the BCA Online Portal.
- Verification Stage 2:** Verification Stage 2 is only applicable only for BCA Green Mark Gold^{PLUS} and Platinum projects. The energy savings for the building over its reference model shall be demonstrated using 12-month actual operational data. The building shall demonstrate compliance to the committed energy savings which resulted in the certification. The relevant documentary evidences are reflected in this Document under *Annex C: Energy Modeling Methodology and Requirements – Verification Stage 2*.

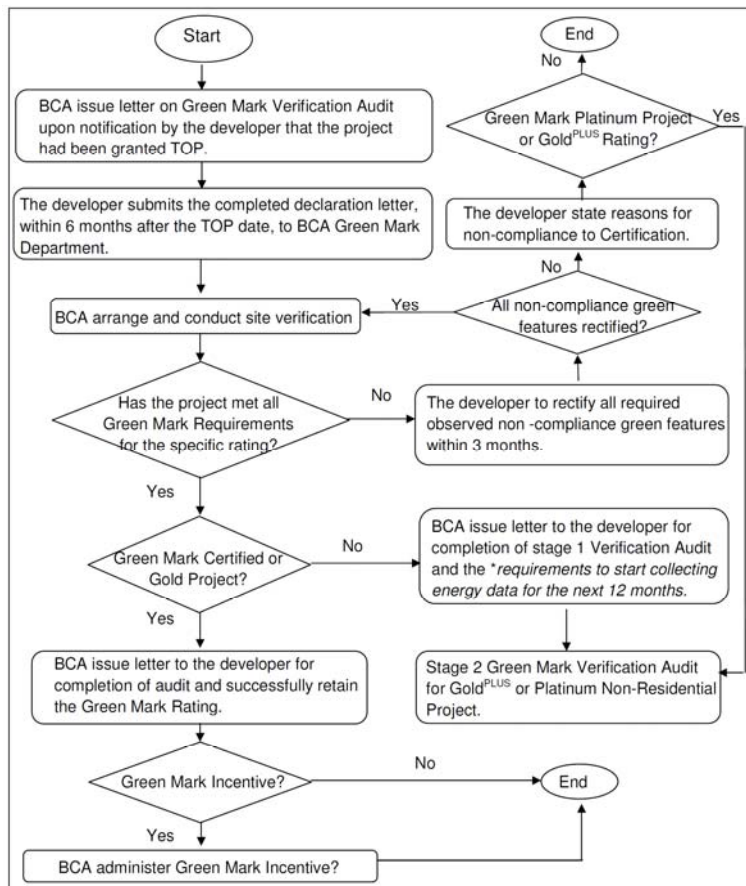

Energy Modeling Requirements

Documentation Requirements

Please refer to *Annex C: Energy Modeling Methodology and Requirements*.

1. Climatic Responsive Design

P.1 Envelope and Roof Thermal Transfer

Definitions

As per the *BCA Code on Envelope Thermal Performance for Buildings*.

Documentation Requirements

(A) Design Stage

- ETTV:
 - Architectural elevation drawings showing the composition of the different façade or wall systems that are relevant to the computation of ETTV
 - Architectural plan layouts and elevations showing all the air-conditioned areas
 - Sectional or elevation drawings showing the relevant shading devices
 - Extracts of the tender specifications or material schedules showing the salient data of the material properties that are to be used for the façade or external wall system
 - ETTV calculation in excel format
- Thermal transmittance (U-value) of the building's roof:
 - Plan layout and sectional details of the different roof types of the development, the roof composition and the respective U-values
 - Tender specification and technical product information that state the thermal conductivity properties of the roof composition
 - Roof U-value calculations

(B) Verification Stage 1

- ETTV:
 - Purchase orders/ delivery orders, for the brands/ models of the glazing and external wall system, stipulating the relevant thermal conductivity, U-value and SC specifications, to demonstrate compliance with the committed building façade thermal performance
 - As-built drawings/ documents showing the material properties of the façade and external walls
 - Revised ETTV calculation in the event of any design or material changes
- Thermal transmittance (U-value) of the building's roof:
 - Purchase orders/ delivery orders of the roof materials
 - As-built drawings/ documents showing the material properties of the roof

- Revised U value calculation in the event of any design or material changes

Worked Example

ETTV

Multiple blocks within the same development:

A proposed building development comprises three building blocks. The individual ETTV of the each building computed are as follows:

$$\begin{array}{l}
 \text{ETTV}_{\text{bldg1}} = 35 \text{ W/m}^2 \quad A_{\text{bldg}} = 5000 \text{ m}^2 \\
 \text{ETTV}_{\text{bldg2}} = 45 \text{ W/m}^2 \quad A_{\text{bldg}} = 6800 \text{ m}^2 \\
 \text{ETTV}_{\text{bldg3}} = 40 \text{ W/m}^2 \quad A_{\text{bldg}} = 7500 \text{ m}^2
 \end{array}
 \left. \vphantom{\begin{array}{l} \text{ETTV}_{\text{bldg1}} \\ \text{ETTV}_{\text{bldg2}} \\ \text{ETTV}_{\text{bldg3}} \end{array}} \right\}
 \begin{array}{l}
 A_{\text{devt}} = 5000+6800+7500 \\
 = 19300 \text{ m}^2
 \end{array}$$

Therefore

ETTV Weighted average

$$\begin{aligned}
 &= \frac{\sum(\text{ETTV}_{\text{bldg}} \times A_{\text{bldg}})}{A_{\text{dvpt}}} \\
 &= \frac{(\text{ETTV}_{\text{bldg1}} \times A_{\text{bldg1}}) + (\text{ETTV}_{\text{bldg2}} \times A_{\text{bldg2}}) + (\text{ETTV}_{\text{bldg3}} \times A_{\text{bldg3}})}{A_{\text{dvpt}}} \\
 &= \frac{(35 \times 5000) + (45 \times 6800) + (40 \times 7500)}{19300} \\
 &= 40.46 \text{ W/m}^2
 \end{aligned}$$

Thus, the overall ETTV meets Gold level certification requirements.

Thermal Transmittance (U-Value) Of the Building's Roof

A development comprises 1 air conditioned block (A) and three non - air- conditioned blocks (B, C, D). The roofs are made of different material types, and the U-value of Roof D is calculated as an example as follows:

Components	Weight (kg/m ²)	Thickness b (m)	k-value (W/m K)	R-value (m ² K/W)
Outside surface film (high emissivity)	-	-	-	0.055
325mm thick RC slab (Density: 2400 kg/m ³)	780	0.325	1.442	0.22538
50mm thick Rockwool insulation (In this example, the density of the particular rockwool used is 40 kg/m ³)	2	0.05	0.036	1.38889
Inside surface film (low emissivity) – Sloped roof 22.5°	-	-	-	0.59500
Total Weight (kg/m ²)	782			
Total R-value R _T				2.26427

Therefore, the U-value of Roof D = $1/R_T = 0.44 \text{ W/m}^2\text{K}$

After proceeding to calculate the U values of Roofs A, B and C (not shown), a summary is as follows:

Roof	Roof Weight Group	U-value of Roof (W/m ² K) (B)	Roof Area (m ²) (C)	Prereq Maximum U-value of Roof Type (W/m ² K) (A)	Complies?
Block A (Air – Conditioned block)	Light	0.47	6000.00	0.5	Yes
B (Non air – Conditioned block)	Medium	0.53	800.00	1.1	Yes
C (Non air – Conditioned block)	Heavy Type 1	0.65	600.00	1.5	Yes
D (Non air – Conditioned block)	Heavy Type 2	0.44	100.00	1.5	Yes

P.2 Air Tightness and Leakage

Documentation Requirements

(A) Design Stage

- Technical specifications showing the relevant tests and details to determine the air leakage limits rates

(B) Verification Stage 1

- Air tightness & leakage testing report from an accredited laboratory

P.3 Bicycle Parking

Documentation Requirements

(A) Design Stage

- Relevant plans showing proposed location of the lots

(B) Verification Stage 1

- Photographs of the bicycle parking lots

1.1 Leadership

1.1a Climatic & Contextually Responsive Brief

Documentation Requirements

(A) Design Stage

- Written statements, reports, documents, correspondences and notes of discussion demonstrating the particular project's briefing process, endorsed by the client or client's representative and acknowledged by the key project team members.

1.1b Integrative Design Process

(i) Integrative Team

Definitions

Design charrette: A collaborative meeting for design and planning. The aim of design charrettes is for the team to jointly set and review sustainability targets, progress and outcomes. They serve as platforms for the various disciplines within the project team to voice opportunities to optimise design, and for the team to work together to evaluate the opportunities against other constraints.

Documentation Requirements

(A) Design Stage

- Reports, documents, correspondences and notes of discussions at the various project stages demonstrating the integrative design process
- Evidences of the implementation of design optimisation arising from the charrettes discussions

(ii) Design for operation

Documentation Requirements

(A) Design Stage

- Reports, documents, correspondences and notes of discussions that Facility Manager's inputs are taken into design considerations

(B) Verification Stage 1

- Evidences of the implementation of the design or features that cater to the maintenance or operational need raised by Facility Manager.

(iii) Use of BIM

Documentation Requirements

(A) Design Stage

- **Collaborative BIM:** BIM Execution Plan showing evidence of BIM Collaboration requirements, and coordinated BIM models of the Architectural, Structural and MEP (Mechanical, Electrical and Plumbing) disciplines
- **Green BIM:** BIM Execution Plan showing evidence of Green BIM requirements, details of the analysis software/ performance plugins used, processes and how this has been employed to evaluate and optimise the building design in areas such as (but not limited to) building energy use, façade heat gains and ETTV, lighting and daylighting analysis, as well as natural ventilation performance etc.

4D, 5D, 6D BIM (Advanced Green Efforts)

Documentation Requirements

(A) Design Stage

- 4D BIM : Report showing virtual planning (including virtual mock-ups and sequencing) of 3 critical areas in the project, and 4D BIM model with information suitable for sequencing, to demonstrate how 4D BIM facilitates actual construction.
- 5D BIM: Evidence of the use of integrated scheduling tools with BIM model and/ or BIM model with information suitable for quantity take-off and cost estimating, to demonstrate how 5D BIM facilitates cost planning and monitoring.
- 6D BIM: Report showing the 6D BIM handover requirements and 6D BIM model with information suitable for facility management.

(B) Verification Stage 1

- Relevant coordinated 4D, 5D and/ or 6D model

1.1c Environmental Credentials of Project Team

Documentation Requirements

(A) Design Stage

- Certified true copy of the certificate of Green Mark Manager (GMM)/ Green Mark Facility Manager (GMFM)/ Green Mark Professional (GMP)/ Green Mark Facility Professional (GMFP) along with the Refresher course certificate (valid for 2 years) where applicable and a confirmation of their involvement and contribution in the project
- Certified true copy of the main builder's Green and Gracious Builder award
- Certified true copy of the valid ISO 14000 certificate of developer, main contractor, M&E consultant, C&S engineer and architect where applicable
- Extracts of SGBC certified companies from SGBC website

Worked Example

A project has the following members in its project team.

- A certified Green Mark Manager who is actively involved in leading the sustainable design process during throughout the various project stages. The Professional Engineer (Mechanical) is a certified Green Mark Professional (0.5 point)
- BCA certified Green and Gracious Builder (Star level) (0.5 point)
- The Architect, Developer and M&E Engineer are ISO 14001 certified (0.75 point)
- The Architect and M&E Engineer are SGBC Certified companies (0.5 point)

Therefore, points scored for 1.1c = 2.25 points

1.1d User Engagement

Guidance Notes

An outline of the Building User Guide is as follows:

- Introduction – An overview of the design, the passive and environmental strategies employed and how they benefit the user.
- Façade and Roof Design
 - Details on how the façade are designed to reduce solar heat gain and facilitate natural ventilation where applicable
- Energy
 - Details of the energy efficient equipment and their operational controls
 - Details of energy labelling for any supplementary equipment and advice on selection
 - Details on how to track energy consumption
- Water
 - Details information on the WELS rated products including water fittings and water efficient system adopted.
 - Details of water conservation strategies and water saving tips
- Waste & Recycling
 - Information on the waste collection strategies
 - Information on waste recycling practices
- Green Transportation and Access
 - Details of bicycle parking provisions
 - Details of the local transportation options to and from the building
- Local Amenities
 - Details of the amenities and facilities within and around the building
- Responsible and Healthy Fit Out
 - Details of the green products used within the building
 - Importance of using green fit-out and low VOC materials
 - Embodied energy of building materials selection
- Responsible Purchasing
 - Advice on green procurement strategies relevant to the type of building occupant
- Others
 - The environmental impact of user behaviour
 - Information on good practices for sustainable building operations relevant to the building users including links to websites, publications and organisations providing information or guidance on environmentally sound operations, environmental tips and initiatives

For green lease, guiding templates (*Office Green Schedule* and *Retail Green Schedule*) may be found in the BCA website.

Documentation Requirements

(A) Design Stage

- Building user guide: Draft of guide prepared and endorsed by the client representative, complete with commitment that it will be circulated.
- Sustainability Education Corner: Location of corner and draft details of the information that will be provided at the corner
- Sustainability Awareness & Education Programme: Commitment from building owner on the operation of programme and draft details of the programme.
- Green fit-out guidelines: Draft guidelines prepared and endorsed by the client representative, complete with commitment that it will be circulated
- Green lease: Draft green lease for specified NLA prepared and endorsed by the client representative, complete with commitment that it will be incorporated into the tenancy agreement with details of procedures to ensure compliance
- Displaying Green Mark Credential: Commitment from building owner to display Green Mark Decal or Green Mark Plaque at prominent location (visible to public) when the project is completed.

(B) Verification Stage 1

- Building user guide: Official building user guide and evidence of its circulation to the respective parties
- Building user guide: Official green fit-out guidelines and evidence of its circulation to the respective parties
- Sustainability Education Corner: Documentary/ photographic evidences of the corner and information provided there.
- Sustainability Awareness & Education Programme: Details of the programme and schedule done/planned.
- Green lease: Official tenancy agreement with green lease and compliance procedures incorporated, complete with evidence of its application to the specific tenants
- Displaying Green Mark Credential: Photographic evidences of Green Mark Decal or Green Mark Plaque.

1.2 Urban Harmony

1.2a Sustainable Urbanism

(i) Environmental Analysis

Documentation Requirements

(A) Design Stage

Submission of an environmental study report, or an Environmental Impact Assessment (EIA) by 3rd party, acknowledged by the client or client representative. The EIA shall be conducted by a competent specialist. The environmental study report shall not necessarily be used to fulfil authority requirements. The report/ EIA should detail:

- The proposed development and its need
- The existing environment of the site
- The impacts of the proposed development and its alternatives on the environment, minimally covering the aspects of climate change, flora and fauna, soil, air and water where applicable

- Recommendations and measures to mitigate any adverse impacts and / or opportunities to improve the site beyond its original condition before the development, i.e. how the ecological features or areas of the site are to be adequately protected from damage or disturbance during the construction activities from site clearance and preparation through to practical completion and handover. (Note: Replacement is not able to be considered as mitigating measures for features of identified value removed in the construction process or site clearance.)
- A non-technical summary

(B) Verification Stage 1

- Documentary/ photographic evidences of the committed environmental mitigation measures implemented during the construction and initial operation of the building.

Creation of Possible New Ecology and Natural Ecosystems (Advanced Green Effort)

Documentation Requirements

(A) Design Stage

- Detailing of strategies to achieve the criteria intent and how the regenerative features are quantified
- Detailing of metrics to be used and tracked during project completion

(B) Verification Stage 1

- A study utilising the agreed metrics at the design stage conducted at suitable intervals during the building's operational life that demonstrates the projects regenerative performance

(ii) Response to Site Context

Guidance Notes

An outline of the site analysis report is as follows:

- Executive Summary – A non-technical summary that summarises the site analysis
- Urban context – The urban form, land use and its impact on the site. This shall include key vistas, view corridors, the urban grain as well nearby amenities
- Site Topography & Hydrology – Land and topographical survey of the site facilitating design decisions based on the site's topographical features, storm water runoff and other key features. This section can link to the EIA under 7.2a (i) if conducted
- Site Micro Climate - Sun/ Wind/ Acoustics/ Views/ Air Quality:
 - Level 1: Identification on plan and photographic evidences of the key micro climatic conditions of the site and how this will be considered in the design
 - Level 2: Macro level simulations, with at least 2 iterations, that analyse the site context on top of level 1.
- Site Access and Connectivity – Details of pedestrian and vehicular traffic, site accessibility and public transport options. The analysis shall investigate the connectivity potential to connect the site to existing green infrastructure such as parks, gardens or cycle routes, as well as sheltered connectivity to public transport. The analysis should also look at physical connectivity feasibility to adjacent buildings (existing or planned)

- Level 1: Concept design studies demonstrating how the functional requirements of the project responds positively to the site context including enhancing site access
- Level 2: Iterative massing studies through macro simulations, **with at least 2 iterations**, that identify how the urban form of the building has been optimised, the location of outdoor amenities have been located to take advantage of the site conditions, including outdoor thermal comfort analysis. The simulations should identify that the building minimises its impact on its neighbours.

Documentation Requirements

(A) Design Stage

- Level 1/ Level 2 site analysis report

Worked Example

This is an example of a Level 1 site analysis carried out through simple sketches to develop building massing, **taking into account the surrounding context.**

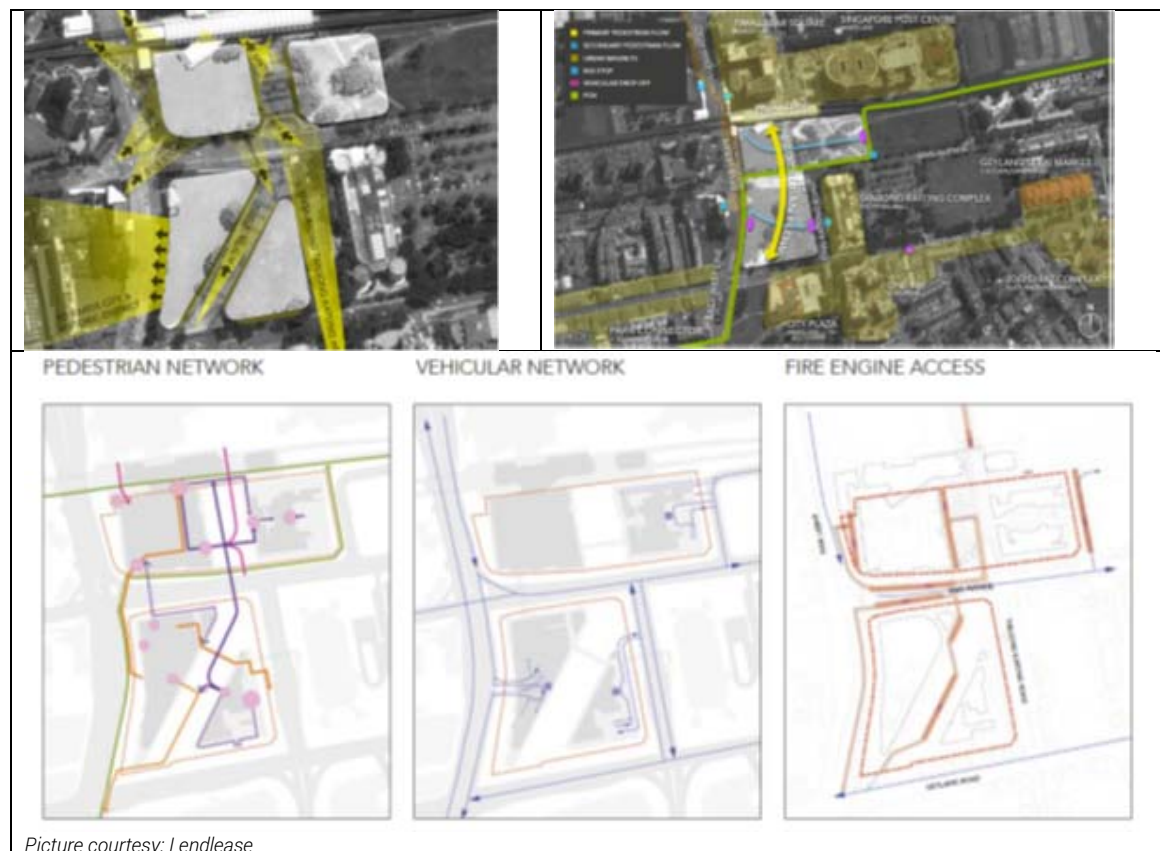

Picture courtesy: Lendlease

(iii) Urban Heat Island (UHI) Mitigation

Guidance Notes

The site plan (2D plan area in m²) can be used to calculate the site coverage of UHI mitigation measures such as:

- Green and blue spaces for landscaping and roof
- Roofing materials or coatings or cool paints with high Solar Reflectance Index (SRI) > 40
- Unshaded hardscape areas with SRI > 39, inclusive of unshaded carparks, internal roads, plazas and pedestrian walkways
- Permeable paving strategies such as gravel or open paving systems
- Other performance based strategies that demonstrate UHI effect mitigation

Areas for renewable energy generation, e.g. where photovoltaic panels are placed, can be deemed to comply.

Documentation Requirements

(A) Design Stage

- Site plan highlighting vegetation, waterbodies, hardscape and roof areas
- Calculation of hardscape areas shaded by vegetation based on a midday sun i.e. the shadow shall correspond to the area directly under the tree canopies. The tree canopy size shall be based on the mature crown size as per NParks guidelines (also referenced under 1.2c (i) *Greenery Provision*)
- Material schedules or specifications of the roof and hardscape finishes with corresponding SRI values. Where such values are not provided, calculations in accordance to *ASTM E1980 – 11* may be used supported by solar reflectance and thermal emittance specifications

(B) Verification Stage 1

- Any design changes to be highlighted on the plan drawing and the areas recalculated
- Photographic evidences of the vegetated areas
- Delivery orders of the hardscape materials and roof finishes supported by technical specifications providing the SRI or solar reflectance and thermal emittance values

(iv) Green Transport

Documentation Requirements

(A) Design Stage

- Electrical vehicle charging and parking infrastructure
 - Extracts of the tender specifications showing the requirement to provide electric vehicle charging and parking infrastructure
 - Plans indicating the location, number and provision of electric vehicle charging and parking infrastructure
- Reduced car park provision below the prevailing car park standard: 'Range Based Car Parking Standard (RCPS)' application approved by LTA
- Features to promote bicycle usage:
 - Extracts of the tender specifications showing the requirement to provide such features

- Plans indicating the location of the features. Examples of features (at least 2 of the features should be implemented in order to score) include:
 - Adequate shower and toilet provision above NEA requirements
 - Adequate provision of lockers
 - Bicycle maintenance facility
 - Comprehensive wayfinding signage
 - Dedicated circulation routes within development for cyclists to access bicycle parking and end-of-trip facilities safely
 - Ground level sheltered parking
 - Innovative bicycle parking designs
 - Security surveillance for bicycle parking

(B) Verification Stage 1

- As-built drawings and photographs highlighting the provision of the committed features

1.2b Integrated Landscape and Waterscape

(i) Greenery Provision

Definitions

Green Plot Ratio (GnPR): GnPR calculates the 3D volume covered by plants using the prescribed Leaf Area Index (LAI) by NParks.

Guidance Notes

The LAI of the individual plant species and its canopy area are predetermined design parameters as listed below:

Plant Group	Trees	Palms	Shrubs & Groundcover	Turf
Leaf Area Index (LAI)	Open Canopy = 2.5 Intermediate Canopy = 3.0 Dense Canopy = 4.0	Solitary = 2.5 Cluster = 4.0	Monocot = 3.5 Dicot = 4.5	2.0
Fixed Area*:	Columnar = 12 m ² Non Columnar = 60 m ²	Solitary = 20 m ² Cluster = 17 m ²	Planted Area	Planted Area

Note: Exceptions apply to trees or palms planted at ≤ 2.0m centres trunk to trunk/ columnar trees as elaborated further below.

The plant species sub-categories and LAI values can be obtained from the online website: <http://florafaunaweb.nparks.gov.sg> by searching the common/ scientific names of the plants.

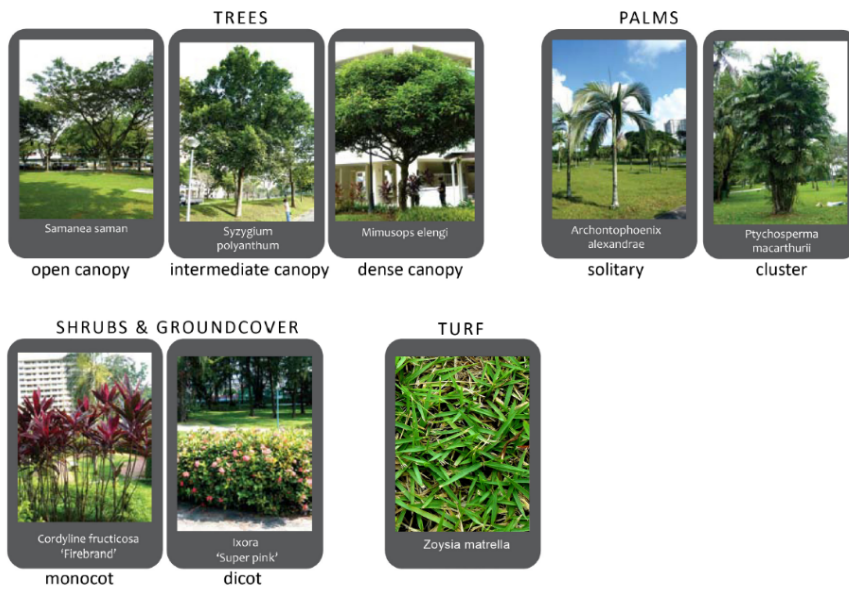

Trees and palms spacing (centre-to-centre): If the selected trees and palms are to be planted at $\leq 2\text{m}$ from trunk-to-trunk as illustrated below, the leaf area shall be calculated as the product of LAI value and planted area

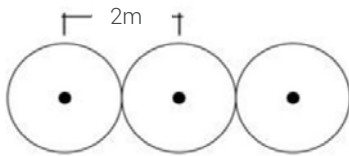

Columnar trees: For trees that have tight, columnar crowns, the canopy area of 12 m^2 is to be adopted for calculation of leaf area. These species include (but not limited to) the following:

- *Garcinia Cymosa Forma Pendula*
- *Garcinia Subelliptica*
- *Polyalthia Longifolia*
- *Carallia Brachiate*
- *Gnetum Gnemon*

Documentation Requirements

(A) Design Stage

- Plan or layout showing the site area as well as the greenery that is provided within the development, including a listing of the number of trees, palms, shrubs, turf and the respective sub category and LAI values
- Calculation showing the extent of the greenery provision and derivation of the GnPR

(B) Verification Stage 1

- As-built landscape drawings and delivery orders of the plants
- Re-computation of GnPR for any reduction in greenery from design stage

Worked Example

Determine the number of trees, palms and the areas for shrubs and turfs and other greenery areas. Then compute the green areas. The table below is shown as an example:

Category	Sub category	(A)	(B)	(C)	(A) x (B) x (C)
		LAI value	Canopy Area	Qty/ Planted Area	Leaf Area
Trees (no.)	Open Canopy	2.5	60 m ²	0 no.	0 m ²
	Intermediate Canopy	3.0	60 m ²	8 no.	1,440 m ²
	Dense Canopy	4.0	60 m ²	12 no.	2,880 m ²
	Intermediate columnar canopy	3.0	12 m ²	4 no.	144 m ²
Palms (no. or m ²)	Solitary	2.5	30 m ²	10 no.	750 m ²
	Solitary (trunk-to trunk ≤ 2m)	2.5	NA	20 m ²	50 m ²
	Cluster	4.0	17 m ²	10 no.	680 m ²
Shrubs (m ²)	Monocot	3.5	NA	0 m ²	0 m ²
	Dicot	4.5	NA	20 m ²	90 m ²
Turf (m ²)	Turf	2.0	NA	90 m ²	180 m ²
Vertical Greenery (m ²)	-	2.0	NA	10 m ²	20 m ²
Total Leaf Area :					6,234 m²

Assuming the site area is 4000m²,

Green Plot Ratio (GnPR) = Total leaf area / site area = 6234 / 4000 = 3.117

Therefore, points scored for 1.2b (i) = 2.5 points.

GnPR ≥ 5 (Advanced Green Efforts)

Documentation Requirements

As per 1.2b Integrated Landscape and Waterscape – 1.2b (i) Greenery Provision.

(ii) Tree Conservation

Documentation Requirements

(A) Design Stage

- Site layouts showing the existing and final locations (where applicable) and number of the trees to be restored or conserved or relocated.
- Existing site plans showing the location and numbers of trees that are to be felled with the identification of the tree species and LAI values. The proposed landscape plans shall show the proposed equivalent number and tree species with LAI values of the replacement trees

(B) Verification Stage 1

- As-built drawings, transplanting records and on site photographs of the conserved trees
- As-built drawings and photographs of the replaced trees

(iii) Sustainable Landscape Management

Documentation Requirements

(A) Design Stage

- LEAF certification: Extracts of the tender, or a signed commitment from the developer / building owner that NParks LEAF certification will be applied for
- Adoption of native species: Landscape plan outlining the native species with a calculation of the % of site coverage
- Landscape management plan: Draft landscape management plan with supporting tender specifications

(B) Verification Stage 1

- LEAF certification: Letter of award or LEAF certificate
- Adoption of native species: Delivery orders of the native species and quantity to be prepared and submitted. Any variations would require a re-tabulation
- Landscape management plan: The completed landscape management plan and implementation records supported by photographic evidences, delivery orders of composts with reports of soil/ compost mixes as well as the landscape maintenance manual

(iv) Sustainable Stormwater Management

Documentation Requirements

(A) Design Stage

- PUB ABC Waters Certification: PUB ABC Waters Certificate
- Provision of infiltration or design features:
 - Design calculation that shows the percentage of site area that is drained to the infiltration or design features for treatment, with endorsement of an ABC Waters Professional
 - Location plan of the relevant infiltration or design features

(B) Verification Stage 1

- Provision of infiltration or design features:
 - Final set of design calculation that shows the percentage of site area that is drained to the infiltration or design features for treatment, with endorsement of an ABC Waters Professional
 - Declaration of an ABC Waters Professional on the % of site area that is drained to the completed infiltration or design features for treatment

1.3 Tropicality

1.3a Tropical Façade Performance

(A) Design Stage

- Checklist method:
 - Excel calculations on how the weighted values were derived
 - Excel calculation of point score in the prescribed template format as in the worked example
- Simulation method:
 - Details of software used, process and extract of simulation results to demonstrate heat load reduction against the notional façade. The model shall accurately reflect the spatial parameters of the building and be created using a DOE 2.0 or equivalent software. The façade shall be modelled as per the notional façade and as per design. The comparison excludes any internal heat gains and internal zoning. The percentage heat load reduction is determined through comparing the result against the notional façade model. The heat gain shall be computed based on relevant climate data (including solar heat gains) based on an annual simulation

(B) Verification Stage 1

- Qualified Person (QP) endorsed as-built drawings of the façade including construction details
- A report highlighting any changes to the façade from that committed at the stage of design assessment and how this affects the performance
- The delivery orders of the materials used in the envelope

Worked Example

An office building has a WWR of North = 0.27, South = 0.40, East = 0.25, West = 0.28. Each façade is 500m². The overall WWR is 0.3. The office has 2 types of wall: basic RC wall for the south façade W1 (area: 300m²; U value: 2.00 W/m²K), and the remaining facades of aluminium cladding composite wall material W2 (total area: 1100m²; U value: 0.39 W/m²K). Windows are all basic double glazed of type F1 (total area = 600m²; U-value: 2.6 W/m²K; SC: 0.65).

$$\begin{aligned} \text{Overall Weighted Envelope U-value} &= \frac{(U_{W1} \times A_{W1}) + (U_{W2} \times A_{W2}) + (U_{F1} \times A_{F1})}{\text{Overall facade area}} \\ &= \frac{(2.0 \times 300) + (0.39 \times 1100) + (2.6 \times 600)}{500 \times 4} \\ &= 1.29 \text{ W/m}^2\text{K} \end{aligned}$$

Sun shading effectiveness is demonstrated through the calculation of the SC₂ using the *Code on Envelope Thermal Performance for Buildings*, where if the SC₂ value is ≤ 0.9, this is equivalent to 10% effectiveness and if it is ≤ 0.7, is equivalent to 30% effectiveness. The weighted shading effectiveness would be taken for buildings where the shading differs for the fenestrations.

In this example the building has no shading devices.

The roof has a U Value of 0.8 W/m²K, and there are no skylights for the project.

Based on this the total points for the façade design is:

Overall Weighted Values	Baseline	Points for Improvement	Points
Envelope U-Value	1.6 W/m ² K	0.5 pt for meeting baseline 0.5 pt for every 0.2 W/m ² K reduction from baseline	$\frac{1.6 - 1.29}{0.2} \times 0.5 + 0.5$ =1.275 pts
WWR (Excludes façade openings/ voids)	0.4 (East, West facades not to exceed 0.3)	1 pt for meeting WWR of 0.4 0.5 pt for every 0.05 reduction from baseline	$\frac{(0.4 - 0.3)}{0.05} \times 0.5 + 1$ =2 pts E, W facades WWR < 0.3
Glass Shading Coefficient (SC _g)	0.4	0.5 pt for meeting baseline 0.5 pt for every 0.05 reduction from baseline	0.65 > 0.4 so no points (If there is a mix of glass types with different SC, to weight them accordingly by area)
Effective Sun Shading	-	≥ 10% effectiveness (North and South) - 1pt ≥ 30% effectiveness (East and West) - 1 pt	0 pt
Roof U-Value	0.8 W/m ² K	1 pt for meeting 0.8 W/m ² K	1 pt
Sky light/ Roof window U-Value	2.2 W/m ² K	0.5 pt for meeting U-Value	0 pt

Therefore, points scored for 1.3a = 4.275 points (capped at 3 pts).

Low Heat Gain Façade

(A) Design Stage

- As per P.1 Envelope and Roof Thermal Transfer

(B) Verification Stage 1

- As per P.1 Envelope and Roof Thermal Transfer

Vertical Greenery on the East and West Façade (Advanced Green Effort)

(A) Design Stage

- Plan layouts showing the vertical greenery provision and building elevations;
- Calculation showing the extent of the vertical greenery provision over the east and west façade area.

(B) Verification Stage 1

- As-built landscape plans

Thermal Bridging (Advanced Green Effort)

Definitions

Thermal barrier profile: A profile composed of two or more metal sections connected by at least one thermally insulating (non-metallic) part. The thermal barrier can be continuous or in parts.

Thermal transmittance value of frame (U_{fr}): The thermal transmittance of the frame design in W/m^2K (incorporating any thermal barrier profile if any). This excludes the thermal transmittance of the glazing.

Guidance Notes

The U_{fr} value of frames may be improved through thermally breaking the frame. According to ISO 10077-2, U_{fr} may be computed through the use of a calibration panel. The following shows a schematic of a generic profile section with calibration panel installed.

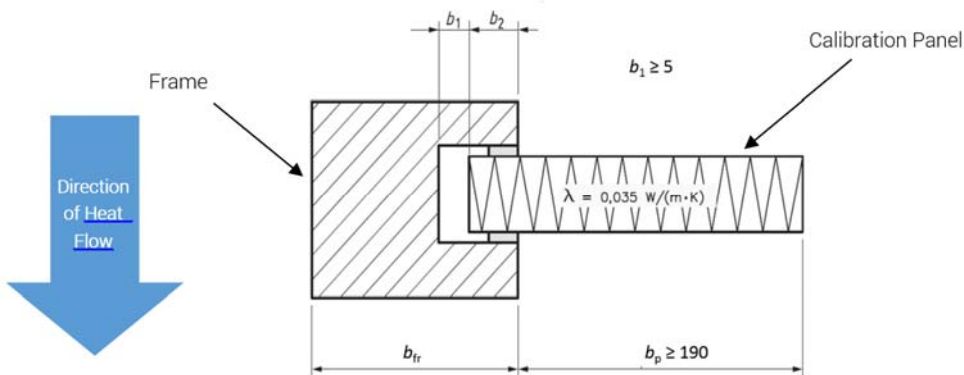

$$L_{fr}^{2D} = U'_{fr} b_{fr} + U'_p b_p$$

$$U_{fr} = \frac{(L_{fr}^{2D} - U_p b_p)}{b_{fr}}$$

Where:

b_{fr} (mm): Projected frame length

b_p (mm): Calibration panel length for 2-D heat transfer effects

L_{fr}^{2D} (W/mK): 2-D heat flow through entire cross section incorporating calibration panel

U_{fr} (W/m^2K): Pure frame U-value as defined in ISO 10077, without the influence of the calibration panel

U'_{fr} (W/m^2K): Frame U-value with calibration panel installed. It is inclusive of the influence from the calibration panel

U_p (W/m^2K): 1-D Calibration panel pure U-value, without the influence of the frame

U'_p (W/m^2K): Calibration panel U-value 190 mm from sightline (or length corresponding to b_p). It is inclusive of the influence from the frame

The use of the calibration panel may be simulated virtually in order to obtain the U_{fr} . When the frame design and material properties have been confirmed, such a thermal simulation report can be easily obtained from the relevant manufacturer or facade consultant. Acceptable simulation software must generate results in accordance with ISO 15099:2003 - *Thermal Performance of Windows, Doors and Shading Devices* and ISO 10077 - *Thermal Performance of Windows, Doors and Shutters*. Simulation must be carried for all different windows/ curtain wall profile sections used in the building project.

Documentary Requirements

(A) Design Stage

- Extracts from the tender specifications showing the requirement to incorporate SGBC certified thermal break/ insulating profile and to achieve U_{fr} value $< 6.0W/m^2K$ for each frame for $\geq 80\%$ of the applicable facades
- Initial design drawings labelling clearly the use of thermal break/ insulation profile

(B) Verification Stage 1

- Thermal frame with thermal break/ insulating profile clearly labelled in the QP endorsed as-built drawings
- Thermal simulation report (from windows/ curtain wall manufacturer or facade consultant) showing that U_{fr} of the relevant facades used in the project complies with the criteria requirements

Worked Example

The following worked example shows the steps to simulate and determine U_{fr} via a thermal simulation report. In this example, a single mullion profile cross-section of a single generic unitized curtain wall system with thermal break/ insulating profiles is used.

1. Import exploded DXF file of the curtain wall profile cross-section into the thermal simulation software as an overlay.

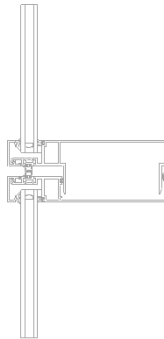
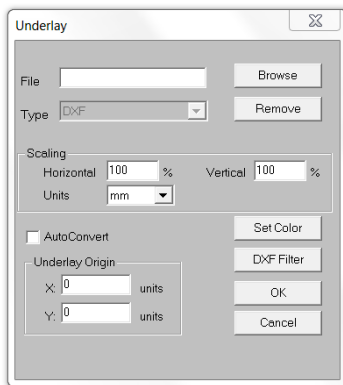

2. Trace the imported curtain wall profile cross-section and assign every element in the profile with appropriate materials from the software's material library.

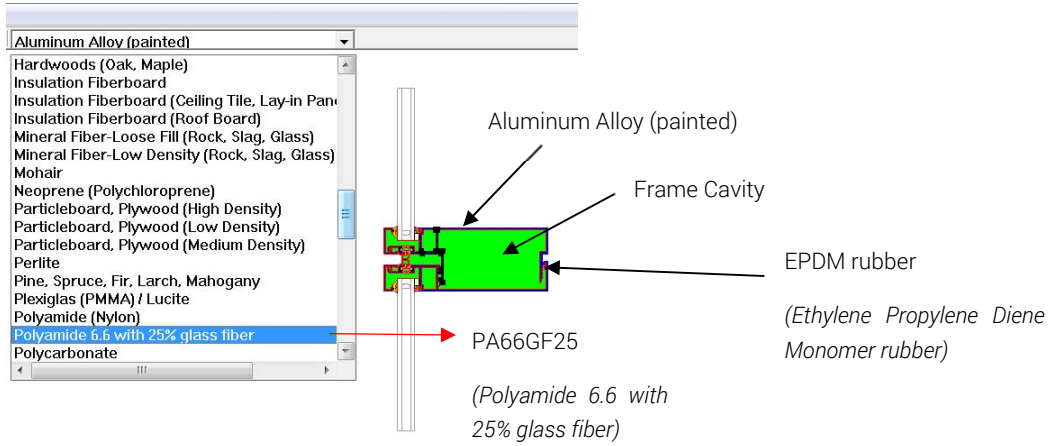

3. Draw a 191mm (from sightline without protruding gasket) calibration panel in place of infills (e.g. glazing, spandrel panels, etc.).

4. Input the properties for the calibration panel.

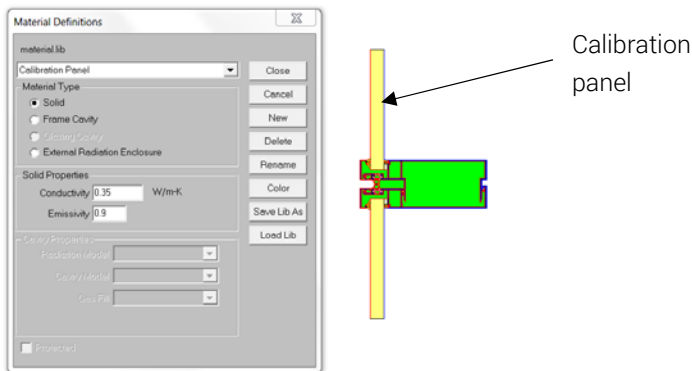

5. Input the relevant boundary conditions for Singapore context.

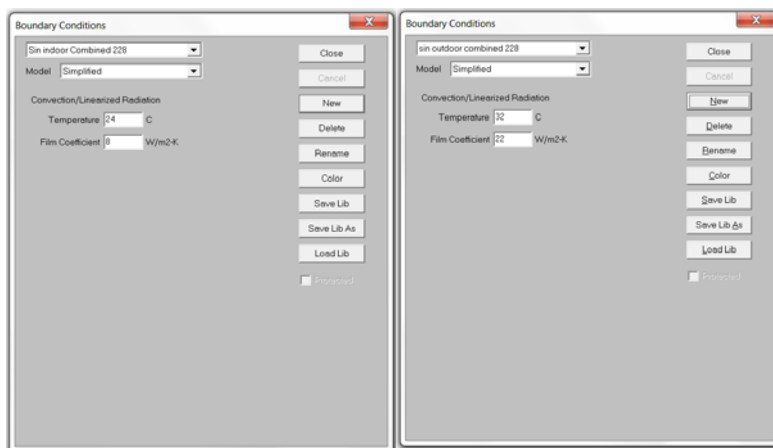

6. Assign the U-value surfaces accordingly (None, Centre of Glazing, Frame & Edge) to boundary condition type (inside or outside) as shown.

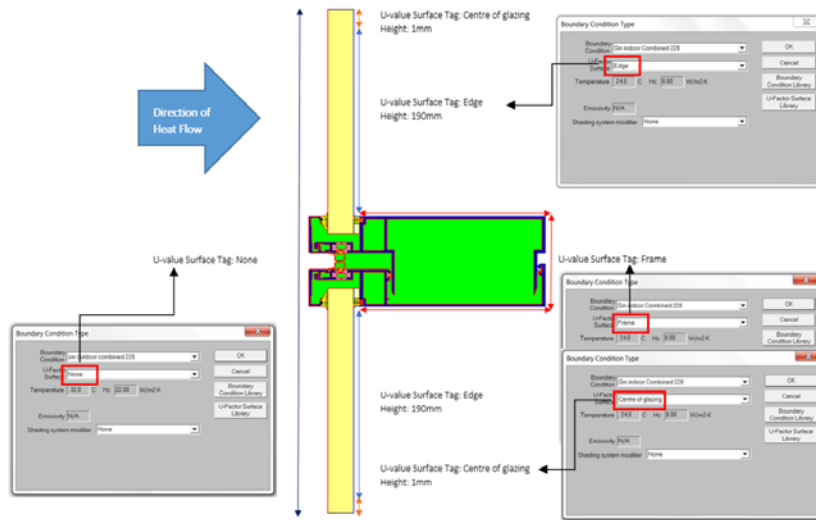

7. Save and run the simulation.

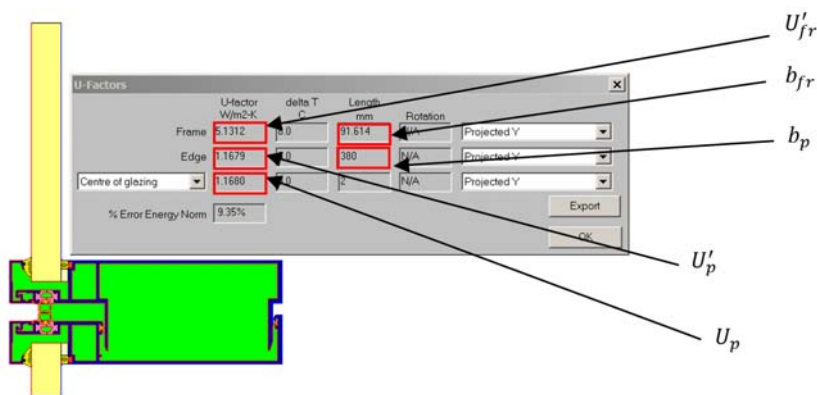

8. Extract these 5 values from the thermal simulation report and input them into the following equations in order to obtain the frame U value.

$$L_{fr}^{2D} = U'_{fr} b_{fr} + U'_p b_p$$

$$= 5.1312 \times \frac{91.614}{1000} + 1.1679 \times \frac{380}{1000}$$

$$= 0.914 \text{ W/mK}$$

$$U_{fr} = \frac{(L_{fr}^{2D} - U_p b_p)}{b_{fr}}$$

$$= \frac{(0.914 - 1.1680 \times \frac{380}{1000})}{\frac{91.614}{1000}}$$

$$= 5.131 \text{ W/m}^2\text{K} < 6 \text{ W/m}^2\text{K}$$

1.3b Internal Organisation

Documentation Requirements

(A) Design Stage

- Location of **non-air-conditioned spaces**: Plans and elevations marking locations of building services and **non air-conditioned** spaces, and the subsequent reduction of conditioned areas directly exposed to eastern and western walls
- Mode of ventilation:
 - Plans and details of the common spaces including façade openings and mode of ventilation
 - Calculations showing the percentage of spaces that are served by the different modes of ventilation

(B) Verification Stage 1

- As-built drawings of the approved spaces

Worked Example

A proposed development has the following details

Facing	Façade areas of A/C areas	Façade areas of non-A/C Area	Total
East	1400	1600	3000
West	1000	2000	3000
Corridors	2400	3600	6000

% of non-A/C façade areas for East and West facing facades = $3800/6000 = 60\% < 2/3$

Hence, point scored = 0.5 point

A proposed development has the following details:

Number of Common Areas	AC	NV	MV	
Toilets	0	10	10	Total number of common spaces = $10 + 20 + 20 = 50$ Total points scored $= \frac{0+40+10}{(10+20+20)} = 1 \text{ point}$
Staircase	0	1	5	
Corridors	0	8	5	
Lift Lobbies	10	1	0	
Total Number	10	20	20	
Weightage	0	2	0.5	Therefore, points scored under 1.3b for mode of ventilation = 1 point
Sum (No. x Weightage)	0	40	10	

1.3c Ventilation Performance

Guidance Notes

Checklist Method

Openings toward prevailing wind directions: This applies to naturally ventilated occupied spaces with window openings facing the north and south directions. The prevailing wind comes from two predominant directions; that is the north to north-east during the Northeast monsoon season and south to south-east during the South-west monsoon season. Hence, spaces with window openings facing the north and south directions have the advantage of the prevailing wind conditions that would enhance indoor thermal comfort. Meteorological data on the more precise wind direction and velocity of the site location can also be used as the basis for the design.

It is not necessary for the window openings to be located perpendicularly to the prevailing wind direction. An oblique angle is considered acceptable. The following is an example of a building layout with all spaces having window openings facing the north and south directions.

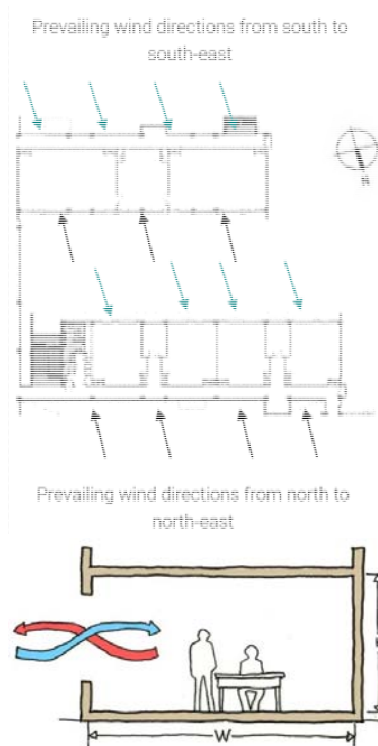

Depth of Room vs Opening - Single sided ventilation: This applies to naturally ventilated occupied spaces with window openings on one side. They shall meet $W \leq 2H$ to score points.

For gathering spaces such as atria which are single-sided, they may apply a factor of 1.5 to the W-H ratio for occupied spaces. This means they can meet $W \leq 3H$ instead to score.

Exceptions: In cases where non-ducted circulation fans are provided (e.g. HVLS fans), they may apply a factor of 2 to the W-H ratio for typical spaces. They mean they can meet up to $W \leq 4H$ instead to score.

Depth of Room vs Opening - Cross ventilation: This applies to naturally ventilated occupied spaces with window openings on opposing sides of the space. They shall meet $W \leq 5H$ to score points.

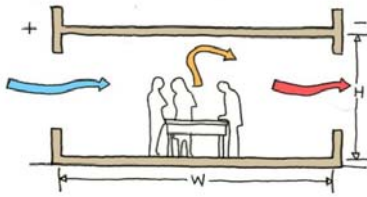

For gathering spaces such as atria which have cross ventilation, they may apply a factor of 1.5 to the W-H ratio for occupied spaces. This means they can meet $W \leq 7.5H$ instead to score.

Exceptions: In cases where non-ducted circulation fans are provided, they may apply a factor of 2 to the W-H ratio for typical spaces. They means they can meet up to $W \leq 10H$ instead to score.

Full Ventilation Simulation

As per *Annex A: Computational Fluid Dynamic Simulation Methodology and Requirements*

Documentation Requirements

(A) Design Stage

- Checklist Method
 - Architectural plan layouts showing the rooms location highlighting of those with window openings in the N-S direction
 - Architectural plan and section/ elevation layouts showing the depth and floor-to-ceiling height and calculated percentage of applicable area.
- CFD Simulation: As per *Annex A: Computational Fluid Dynamic Simulation Methodology and Requirements*

(B) Verification Stage 1

- Demonstrate compliance with the committed design specifications making reference to the as-built drawings

Worked Example

Checklist Method

A school comprises the following:

- Block A: 4 out of 10 classrooms have opposite window openings facing the N-S direction. The rest of the classrooms have single-sided window openings. The classrooms are naturally ventilated with dimensions $H = 3.5$ m, $W = 8$ m
- Block B: All the 8 classrooms have opposite window openings facing the E-W direction. The classrooms are naturally ventilated with dimensions $H = 3.5$ m, $W = 8$ m
- Block C: All the 5 rooms in this block are air-conditioned, e.g. administrative office, meeting rooms, lecture rooms, auditorium and computer rooms
- A naturally ventilated atrium ($H: 5$ m, $W: 14$ m) with openings on opposite sides facing the N-S direction

Space type	Fulfilled Requirement for Depth of Room vs Opening?	Openings facing N-S?
4 cross-ventilated classrooms with opposite window openings facing the N-S direction	W/H = 8/3.5 = 2.3 Fulfils requirement of $W \leq 5H$	Yes
6 classrooms with single-sided openings	W/H = 8/3.5 = 2.3 Does not fulfil requirement of $W \leq 2H$	No
8 cross-ventilated classrooms with opposite window openings facing the E-W direction	W/H = 8/3.5 = 2.3 Fulfils requirement of $W \leq 5H$	No
A naturally ventilated atrium with openings on both sides	W/H = 14/5 = 2.8 Fulfils requirement of $W \leq 7.5H$	Yes
Total percentage	Percentage of spaces which fulfilled requirement of depth of room vs opening = $\frac{4+8+1}{4+6+8+1} \times 100\% = 68.4\%$	Percentage of spaces with openings towards prevailing wind directions = $\frac{4+1}{4+6+8+1} \times 100\% = 26.3\%$

Total points for openings towards prevailing wind directions = $\frac{26.3}{10} \times 0.1 = 0.26$ points

Total points for depth of room vs opening = 1 point ($\geq 50\%$ of applicable spaces meet)

Total points for effective ventilation based on checklist method = 1.26 points

Ventilation Simulation

A project has at least 7,350m² of naturally ventilated occupied spaces and is targeting Gold^{PLUS} certification. It would first need to perform a natural ventilation simulation with results and recommendations implemented. However, after doing so, less than 70% of its naturally ventilated spaces are able to meet a minimum area-weighted velocity of at least 0.4 m/s due to certain constraints. The spaces thus can achieve at least Moderate ventilation performance but is unable to meet Good natural ventilation performance required of Gold^{PLUS} projects. It would then need to carry out either thermal comfort or air quality simulation (it is eligible to do so as the spaces can achieve at least Moderate ventilation performance). It must prove all its naturally ventilated spaces can either achieve PMV within the stipulated range via thermal comfort modeling, or achieve an air change rate and air exchange effectiveness meeting the stipulated requirements via air quality modeling. Thereafter, it would be deemed to comply with the prerequisite requirement for Gold^{PLUS} and achieve 4 points in the criteria.

Wind Driven Rain (Advanced Green Efforts)

Documentation Requirements

As per Annex A: Computational Fluid Dynamic Simulation Methodology and Requirements

2. Building Energy Performance

P.4 Air Conditioning Total System and Component Efficiency

Definitions

Peak building cooling load: Determined based on design day conditions, namely where solar gains and outdoor temperatures are at their highest and there is full occupancy.

Design Total System Efficiency (DSE): The efficiency of the air-conditioning system including the air distribution equipment (e.g. PAHUs, AHUs, FCUs) in kW/RT.

Unitary Air-Conditioning Systems

DSE = Unitary Cooling Equipment Efficiency + Air Distribution Efficiency

The unitary cooling efficiency component of the DSE (excluding the air distribution components) is computed based on the total weighted system efficiency. The formula used is $3.517 / \text{COP}_{\text{weighted}}$. For variable refrigerant flow (VRF) system, the efficiency should be based on normal design dry-bulb temperature of $24 \pm 1^\circ \text{C}$ and relative humidity $\text{RH} \leq 65\%$. The efficiency can be computed based on the full installed capacity of outdoor condensing units or part-load efficiency of the system. Where there are more than one most frequent occurring part-load conditions for the building operation hours specified, the efficiency shall be based on the worst case scenario.

System Zone: Each system zone shall be simulated. A system zone is the internal area that served by a singular unitary system which is determined by the condenser unit and the connected fan coil units/ air handling units.

Weighted Coefficient of Performance: $\text{COP}_{\text{weighted}}$ refers to the weighted Coefficient of Performance. It is calculated via the following formula from NEA: $\text{COP}_{\text{weighted}} = 0.4 \times \text{COP}_{100\%} + 0.6 \times \text{COP}_{50\%}$

$\text{COP}_{100\%}$ is defined as the ratio of the cooling capacity to effective power input at full load cooling capacity.

$\text{COP}_{50\%}$ is defined as the ratio of the cooling capacity to effective power input at 50% cooling capacity.

Weighted Operational Cooling Load: $\text{RT}_{\text{weighted}}$ refers to the weighted operational cooling load of the unitary system in RTH. It is calculated based on the operational schedule of the systems as follows:

$$\text{RT}_{\text{weighted}} = 0.4 \times \text{RT}_{100\%} + 0.6 \times \text{RT}_{50\%}$$

$\text{RT}_{100\%}$ is the installed capacity of the zone (excluding standby units).

$\text{RT}_{50\%}$ is 50% of the installed capacity of the zone (excluding standby units).

Water-Cooled/ Air-Cooled Chilled Water Plants

DSE = Chiller Plant Efficiency + Air Distribution Efficiency

The design system efficiency (DSE) is computed based on the annual energy consumption (kWh) of the system over the annual cooling consumption in RTh. The units are in kW/RT.

Operational design cooling load: The operational building cooling load profile shall be simulated for one whole year to generate the average cooling load over the building's operational hours for one day in RTh. The annual cooling consumption shall be computed based on the following operational hours:

Building Type	Operational Hours
Office Buildings	9 a.m. to 6 p.m. (Monday to Friday)
Retail Malls	10 a.m. to 10 p.m.
Hotels	24 hours
Other Building Types	To be determined based on operating hours

District Cooling System (DCS)

DSE = DCS Plant Efficiency + Air Distribution Efficiency

The DCS plant efficiency refers to the annual electricity consumption of a DCS plant (kWh) over the annual cooling consumption (RTh) of the DCS plant. The operation hours are assumed to be 24 hrs operation per day x 365 days. The relevant equipment for the computation of the DCS plant efficiency includes those within the DCS Plant boundary.

Other auxiliary services for the DCS plant room (electricity consumption from lighting, mechanical ventilation, air-conditioning systems, receptacle loads etc.) can be excluded from the plant efficiency computation. The energy generated by the photovoltaic system at the plant can also be used to offset the total energy consumed by the DCS plant. The energy efficiency of the DCS plant shall be measured over 8,760 hours in a year.

The air distribution efficiency applies to the customer building's air distribution system. It excludes the customer chilled water pumps.

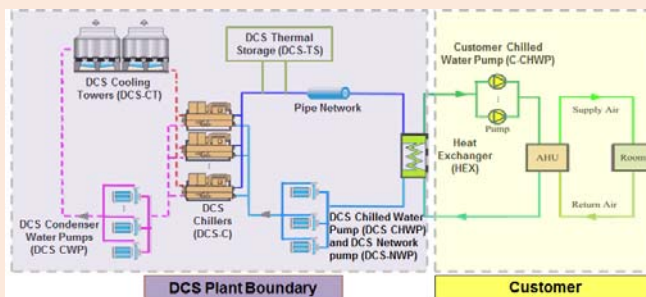

DCS Plant Boundary (includes but not limited to the following equipment)

- DCS Chilled Water Pumps (DCS-CHWP)
- DCS Chillers (DCS-C)
- DCS Condenser Water Pumps (DCS-CWP)
- DCS Cooling Towers (DCS-CT)
- DCS Network pump (DCS-NWP)
- DCS Thermal Storage (DCS-TS)
- DCS Heat Exchanger (HEX)

Customer Boundary

- Customer Chilled Water Pump (C-CHWP)
- Customer Air Distribution System (e.g. AHUs, PAHUs, FCUs)

Guidance Notes

For buildings with different air-conditioning systems, the system and component efficiencies required to fulfil the prerequisite shall only be that of the system with the larger aggregated capacity. On the other hand, the efficiency values used to score points under 2.1a and/ or 2.1e shall be weighted based on the efficiencies of all the different air-conditioning systems used within the building.

Documentation Requirements

(A) Design Stage

- Drawings showing the schematic and layout of the proposed building cooling system (for new cooling systems)
- Plan layouts showing the mode of ventilation of spaces within the building as well as the location of the plant room and cooling towers
- Technical specifications and product information of the various components of the cooling system (for new cooling systems) and air distribution system designed and installed
- Part load performance curves, pump head (for pumps of new cooling systems) and fan static pressure calculations
- For Gold^{PLUS} and Platinum projects: Detailed calculations of fan input power for each PAU, AHU and FCU in the building based on operational design load
- Detailed calculations of the DSE that include the cooling load profile in the prescribed format as shown in the worked examples

Note for buildings served by DCS: The load profile of the specific customer building is to be determined by the project team over the operational hours prescribed by BCA. The energy efficiency of the DCS plant shall be computed by the DCS company based on the total cooling demand of the customer buildings connected and/ or confirmed to be connected to the plant. Evidences of the connection and supply of cooling provision between the customer building and the DCS company shall also be shown. For existing DCS plants commissioned before Oct 2016, the energy efficiency of the DCS plant can be excluded from P.4 and energy modeling savings computation if valid clearance from BCA is given to adopt Path B, but information shall still be provided by the DCS company for the computation of EEI/ EUI. For new building projects aiming for higher Green Mark ratings and tapping onto new DCS plants commissioned after Oct 2016, the baseline will be similar to standalone chiller plant system, stipulated in Annex C Energy Modelling Methodology and Requirements. The computation of energy saving for intended rating will be computed based on energy consumption comparison of the proposed air-conditioning system with the baseline model.*

*The DCS company shall submit the following documentation to BCA for BCA to issue clearance to adopt Path B. If the submission is satisfactory, BCA shall issue clearance, valid for 3 years from the date of issue. The developer/ owner of the building targeting Green Mark rating should check with the DCS company early in the project stage on the plant's eligibility to adopt Path B:

- Completed Energy Audit Report of the DCS plant and proof of installation of M&V instrumentation (compliance with Verification requirements under section P.14 *Permanent Instrumentation for the Measurement and Verification of Air Conditioning Systems*). The report shall be endorsed by PE(Mechanical) or Energy Auditor of the plant
- Operating conditions, energy efficiency and schematics of the equipment and measurement instrumentation of the DCS plant

- Energy efficiency roadmap of the DCS plant and commitment by the DCS company that the efficiency of the equipment within the defined DCS Plant Boundary shall be 0.65 kW/RT or better by 2025. The roadmap shall include the retrofitting plans and plant efficiency target at years 2016, 2019, 2022 and 2025.

(B) Verification Stage 1

- Delivery orders and as-built drawings of cooling system (for new systems) and air distribution systems (for Gold^{PLUS} and Platinum project)
- Area and operating hours of the spaces served by the air-conditioning system
- Compliance with verification requirements under *P.14 Permanent Instrumentation for the Measurement and Verification of Water-Cooled Chilled Water Plant* where applicable
- Chilled-water plants: Completed Energy Audit Report (Green Mark NRB: 2015) endorsed by PE(Mechanical) or Energy Auditor including the power for the air distribution system detailing the total operational performance measured over a 1 week period. (The Report template may be found at [http://www.bca.gov.sg/GreenMark/others/Energy_Audit_Report_\(GM_NRB2015\).doc](http://www.bca.gov.sg/GreenMark/others/Energy_Audit_Report_(GM_NRB2015).doc))
- Unitary/ split systems: Power consumption of the unitary systems
- DCS: For Path A, as per in-house chilled water plants but both the PE/ EA of the plant and of the customer building shall endorse the Report For Path B, as per-in house chilled water plants but only for the air distribution system, endorsed by PE/ EA of the customer building. Valid clearance from BCA to adopt Path B shall be shown

(Note: As-built drawings showing the connection and supply of cooling provision between the building owner and the DCS company shall be submitted. At least one month's bill paid by the customer building to the DCS company when the customer building is reasonably occupied shall be provided to calculate the annual cooling demand of the customer building)

Worked Example

An office building is served by an in-building chilled water plant, and has an air-conditioned floor area of 67,500 m². Variable-speed drives are designed to control the speed of the chilled-water pumps and cooling tower fans. The building is also served by a VRF system during the night-time for certain areas. However, as the tonnage of the chiller plant is larger, *P.4* is only applicable to the chiller plant. The project is targeting Green Mark Gold, hence the minimum chiller plant efficiency for water cooled chilled water plant building to achieve Gold level of certification is 0.68 kW/RT. There are no prerequisite requirements for the air distribution equipment for Gold projects.

Step 1 – Determine the peak building cooling load and relevant baseline

Simulation of annual building cooling load profile shall be carried out to determine the daily average cooling load profile, peak building cooling load and the relevant baseline standard.

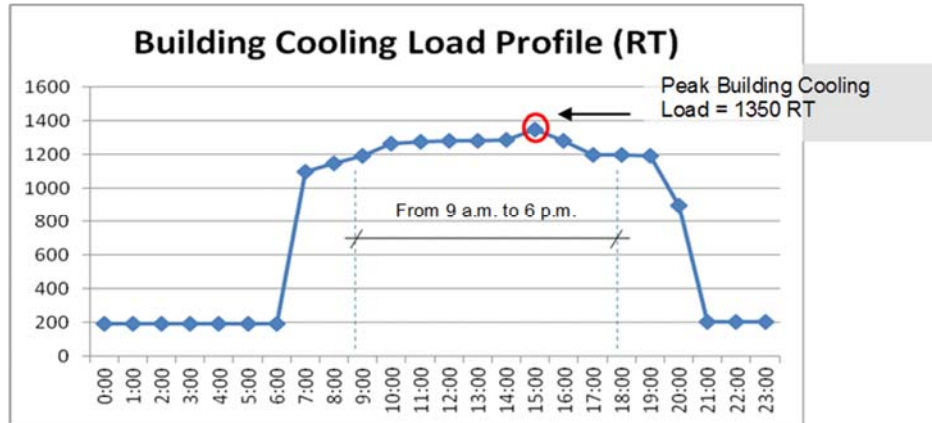

Time	Average Cooling Load (RT)
8:00	1,150
9:00	1,190
10:00	1,260
11:00	1,260
12:00	1,260
13:00	1,260
14:00	1,260
15:00	1,260
16:00	1,190
17:00	1,190
18:00	1,190
19:00	980

From the simulated building cooling load profile, the peak building cooling load is found to be 1,350 RT (≥ 500 RT).

Step 2 – Propose air-conditioning plant configuration and derive the respective power input of various components

The proposed air-conditioning plant configuration for the building operating hours specified are as follows:

- Chillers: 3 nos. x 700 RT (2 duty and 1 stand by)
- Chilled Water Pumps: 3 nos. x 45 kW (2 duty and 1 stand by)
- Condenser Water Pumps: 3 nos. x 37 kW (2 duty and 1 stand by)
- Cooling Towers: 3 nos. x 900 RT (2 duty and 1 stand by). Each cooling tower has 3 no. of 7.5 kW fans

It is important to design the air-conditioning plant configuration for other load conditions that are not within the building operating hours specified, although this is not required for DSE calculation purposes.

2(a) Centrifugal water-cooled chiller (700 RT)

Based on the performance data of the selected chillers from manufacturer:

% Load	Capacity (RT)	Chiller Input Power (kW)	Chiller Efficiency kW/RT	Evaporator		Condenser	
				CHWST (°C)	CHWRT (°C)	CWST (°C)	CWRT (°C)
100	700	363	0.519	6.67	12.31	29.68	34.80
90	630	329	0.522	6.67	12.31	29.68	34.29
80	560	291	0.520	6.67	12.31	29.68	33.78
70	490	260	0.533	6.67	12.31	29.68	33.28

Installed capacity of the chillers (excluding standby) = 1,400 RT

Chillers configuration: 2 x 700 RT centrifugal chillers (operating);
1 x 700 RT centrifugal chiller (standby)

Based on simulated total building load profile, we have:

Time	Cooling Load (RT)	No. of Chillers in Operation	Chiller Efficiency	Chiller Input Power (kW)
From 900 to 1000 and 1500 to 1800	1,190 RT	2 x 700RT @ 85%	0.521	620
From 1000 to 1500	1,260 RT	2 x 700RT @ 90%	0.522	658

2(b) Chilled-water pumps (primary only):

- 2 nos. x 45 kW primary chilled-water pump to be installed with Variable Speed Drive (VSD)
- Water flow rate per pump at full load (Q) = 106 L/s
- Operating static head (h) = 28 m
- Pump efficiency (η_p) = 86.8 %
- Motor efficiency (η_m) = 94.2 %

$$\text{Power requirement of chilled-water pump at full load (kW)} = \frac{(Q)(\rho)(g)(h)}{(10^6)(\eta_p)(\eta_m)}$$

Where

Q : Water flow rate in L/s

ρ : Density of water in kg/m³

g : Gravitational acceleration in m/s²

h : Static pressure head m

η_p : Pump efficiency

η_m : Motor efficiency

$$\text{Power requirement of chilled-water pump (kW)} = \frac{(106)(1000)(9.81)(28)}{(10^6)(0.868)(0.942)} = 35.61 \text{ kW}$$

$$\text{Power of 2 pumps @ full load} = 35.61 \text{ kW} \times 2 = 71.22 \text{ kW}$$

The following equation for pump part-load power curve, referenced from Appendix 5.7 of the *Non-Residential Alternative Calculation Method Reference Manual 2013* by the California Energy Commission (CEC) is used in this example to estimate the pump power at the part load conditions:

$$\text{Pump power ratio} = 0.0205x + 0.4101x^2 + 0.5753x^3$$

where x is the part load ratio.

While the project team can propose other equivalent methodologies, the affinity law is not recommended as it does not take into account losses during actual operating conditions.

$$\begin{aligned} \text{Total pump power @ 85\% part-load (kW)} &= \text{Total Pump power @ full load} \times \text{Pump power ratio} \\ &= 71.22 \times 0.66703 \\ &= 47.50 \text{ kW (When } x=0.85, \text{ the corresponding power ratio is } 0.66703) \end{aligned}$$

$$\begin{aligned} \text{Total pump power @ 90\% part-load (kW)} &= 71.22 \times 0.77002 \\ &= 54.84 \text{ kW (When } x=0.9, \text{ the corresponding power ratio is } 0.77002) \end{aligned}$$

Cooling Load (RT)	No. of Chilled-Water Pumps in Operation	Total Operating Pump Power (kW)
1,190 RT	2 x 45 kW @ 85%	47.50
1,260 RT	2 x 45 kW @ 90%	54.84

2(c) Condenser water pumps:

- 2 nos. x 55 kW condenser water pumps to be installed with VSD
- Water flow rate for the condenser water pump (Q) = 132.5 L/s
- Operating static head (h) = 20 m
- Pump efficiency (η_p) = 88.5%
- Motor efficiency (η_m) = 94.7%

Power requirement of condenser water pump at full load (kW)

$$= \frac{(132.5)(1000)(9.81)(20)}{(10^6)(0.885)(0.947)} = 31.02 \text{ kW}$$

$$\begin{aligned} \text{Power of 2 pumps @ full load} &= 31.02 \text{ kW} \times 2 \\ &= 62.04 \text{ kW} \end{aligned}$$

Although VSD is installed, the flow is fixed at 45Hz (90%). Hence, power consumption is fixed at 90%.

Using the pump part-load power curve equation,

$$\begin{aligned} \text{Total pump power @ 90\% part-load (kW)} &= 62.04 \times 0.77002 \\ &= 47.77 \text{ kW (When } x=0.9, \text{ the corresponding power ratio is } 0.77002) \end{aligned}$$

Cooling Load (RT)	No. of Condenser Water Pumps in operation	Total Operating Pump Power (kW)
1,190 RT	2 x 37 kW @ 90%	47.77
1,260 RT	2 x 37 kW @ 90%	47.77

2(d) Cooling towers:

- 2 nos. of cooling towers to be installed with VSD
- Heat rejection capacity per cooling tower = 900 RT
- Total heat rejection for 2 x cooling towers = 1,800 RT
- Each cooling tower with 3 fan cells with fan motor = 7.5 kW
- Fan motor efficiency = 92%
- Input power per cooling tower = (7.5 kW x 3 fans) / 92% = 24.46 kW
- Total input power for 2 nos. of cooling towers = 24.46 kW x 2 = 48.92 kW

In general, total heat rejection of chiller plant (kW) = Total Cooling load (kW) + Total electrical power input of chiller compressor (kW)

The following equation for cooling tower power adjustment curve, referenced from Appendix 5.7 of the *Non-Residential Alternative Calculation Method Reference Manual 2013* by the California Energy Commission (CEC) is used in this example to estimate the pump power at the part load conditions:

$$\text{Cooling tower fan power ratio} = 0.331629 - 0.885676x + 0.605565x^2 + 0.948482x^3$$

where x is the part load ratio.

While the project team can propose other equivalent methodologies, the affinity law is not recommended as it does not take into account losses during actual operating conditions.

$$\begin{aligned} \text{Fan power @ 76\% part-load (kW)} &= \text{Fan power @ full load} \times \text{Cooling tower fan power ratio} \\ &= 48.92 \times 0.42465 \\ &= 20.77 \text{ kW (When } x=0.76, \text{ the corresponding power ratio is } 0.42465) \end{aligned}$$

$$\begin{aligned} \text{Pump power @ 80\% part-load (kW)} &= 48.92 \times 0.4963 \\ &= 24.28 \text{ kW (When } x=0.8, \text{ the corresponding power ratio is } 0.4963) \end{aligned}$$

Cooling Load	Chiller Input Power	Required Heat Rejection	Total Heat Rejection capacity for 2 no. of Cooling Towers	Percentage Loading for Required and Available Heat Rejection	Total Fan Motor Power at Required Part-Load Condition
A (RT)	B (kW)	C = A + (B/3.517) (RT)	D (RT)	C / D x 100% (%)	(kW)
1,190 RT	620	1,366.28	1,800	76%	20.78
1,260 RT	658	1,447.08	1,800	80%	24.28

Step 4 – Derive the Chiller Plant Efficiency (DSE)

Since this example is an office building, the hours of operation for the calculation of the DSE are to be 9 AM to 6 PM.

Hours	Daily Average Cooling Load (RT)	Chillers Power Input (kW)	CHW Pumps Power (kW)	CW Pumps Power (kW)	CT Power (kW)	Total Power Input (kW)	Chiller Configuration
9:00:00 AM	1,190	620	47.50	47.77	20.78	736.05	2 x700
10:00:00 AM	1,260	658	54.84	47.77	24.28	784.89	2 x700
11:00:00 AM	1,260	658	54.84	47.77	24.28	784.89	2 x700
12:00:00 PM	1,260	658	54.84	47.77	24.28	784.89	2 x700
1:00:00 PM	1,260	658	54.84	47.77	24.28	784.89	2 x700
2:00:00 PM	1,260	658	54.84	47.77	24.28	784.89	2 x700
3:00:00 PM	1,260	658	54.84	47.77	24.28	784.89	2 x700
4:00:00 PM	1,190	620	47.50	47.77	20.78	736.05	2 x700
5:00:00 PM	1,190	620	47.50	47.77	20.78	736.05	2 x700

6:00:00 PM	1,190	620	47.50	47.77	20.78	736.05	2 x700
Daily Consumption (9:00:00 AM to 6:00:00 PM)	12,320 RTh	6,428 kWh	519.04 kWh	477.70 kWh	226.80 kWh	7,653.54 kWh	
Chiller Plant Efficiency kW/RT		0.522	0.042	0.038	0.019	0.62	

Chiller Plant Efficiency of the proposed building cooling system = Total Energy Consumption/Total Cooling = 7,665.44/12,320 = 0.62 kW/RT.

The project achieves design system efficiency of 0.62 kW/RT, thus meeting the pre-requisite requirement for Gold level of certification of ≤ 0.68 kW/RT.

For higher awards projects, the power consumption of the air distribution equipment should be computed as well to derive the total DSE.

P.5 Lighting Efficiency and Controls

Documentation Requirements

(A) Design Stage

- Lighting layout plans and schedules showing the numbers, locations and types of lighting luminaries used.
- Technical product information of the luminaries used/ data sheets
- Lighting level simulation showing the resultant lux level and uniformity of the lighting design that meets or surpasses prevailing code requirements
- Lighting control circuitry plans showing compliance to the stated requirements

(B) Verification Stage 1

- As-built lighting layout, lighting schedule and luminaries' data sheets
- Purchase Orders (POs) or Delivery Orders (DOs) of the luminaries used in the project
- Documentation of onsite verification of the as-built lighting lux level achieved
- As-built lighting control circuitry plans

P.6 Vertical Transportation Efficiency

Documentation Requirements

(A) Design Stage

- Extracts of specifications that indicate the types of lifts, escalators and related features used

(B) Verification Stage 1

- Purchase orders/ delivery orders of the installed lifts and/or escalators to demonstrate compliance with the committed design specifications
- Product catalogue as supplementary documents to PO/DO for making reference of the installed lifts and/or escalators

2.1 Energy Efficiency

Option 1: Energy Performance Points Calculator

Guidance Notes

The Energy Performance Points Calculator shall be used to compute the points for this option.

2.1a Air Conditioning Total System Efficiency

Documentation Requirements

(A) Design Stage

- As per *P.4 Air Conditioning Total System and Component Efficiency*. Information such as equipment specifications about the air distribution information to be submitted.
- Energy Performance Points Calculator excel file
- For computation of fan power, 5% driver loss needs to be accounted for the use of VSD. Project team can use lower value if they can substantiate VSD loss with documentation.

(B) Verification Stage 1

- As per *P.4 Air Conditioning Total System and Component Efficiency*. All projects shall submit air distribution information
- Energy Performance Points Calculator excel file revised with as-built information (if there are any deviations from the inputs in the file submitted during design stage)

Worked Example

Example 1: Computation of the various efficiencies and final points under 2.1a for a theoretical office building which has an air cooled chilled water system, unitary/ split system as well as a water cooled chilled water system is shown. The operating hours for office buildings as specified: Monday to Friday: 9 a.m. to 6 p.m.

(a) Air Cooled Chilled Water System

Using the Energy Performance Points Calculator, the following inputs are given to determine the DSE of the air-cooled system:

- Average Cooling Load
- Chiller Power input (P_{CH})
- Chilled water Pump Power (P_{CHWP})
- Total Airside Constant flow (CF) or Variable Flow (VF) Motor Input Power (*the total hourly motor input power is based on the aggregate of all constant or variable flow fans operating at this hour. For Variable Fan flow, the part load fan power calculator may be referenced from ASRHAE 90.1, Table G3.1.3.15 - Part-Load Performance for VAV Fan Systems or Part-Load Fan Power Equation*)

Hrs	Air Cooled Chiller Plant System					
	Daily Avg. Cooling Load (RT)	P _{CH} (kW)	P _{CHWP} (kW)	Chiller Plant Total Power (kW)	Chiller Plant (kW/RT)	Chiller configuration
9:00:00 AM	361	285	12	297	0.82	500RT X 1 nos
10:00:00 AM	349	275	11	286	0.82	500RT X 1 nos
11:00:00 AM	450	353	19	371	0.82	500RT X 1 nos
12:00:00 PM	447	351	18	369	0.82	500RT X 1 nos
1:00:00 PM	437	340	18	358	0.82	500RT X 1 nos
2:00:00 PM	459	360	19	379	0.83	500RT X 1 nos
3:00:00 PM	454	356	19	375	0.83	500RT X 1 nos
4:00:00 PM	413	322	16	337	0.82	500RT X 1 nos
5:00:00 PM	373	295	13	307	0.82	500RT X 1 nos
6:00:00 PM	309	253	9	262	0.85	500RT X 1 nos
Daily Consumption (9:00AM - 6.00PM)	4,054 RTh	3,188 kWh	154 kWh	3,341 kWh	kWh/RTh = 0.82	

Hrs	Air-Distribution System					Total System	
	CF Power (kW)	Air-Side VF Power (kW)	Total Air Distribution Power (kW)	Air Distribution Efficiency (kW/RT)	Air Distribution Configuration	Total Airside + Chilled-Water Systems Power (kW)	Total Air + Chilled-Water System Efficiency (kW/RT)
9:00:00 AM	0.00	88	88	0.24	VAV	385	1.07
10:00:00 AM	0.00	85	85	0.24	VAV	372	1.07
11:00:00 AM	0.00	100	100	0.22	VAV	472	1.05
12:00:00 PM	0.00	101	101	0.23	VAV	470	1.05
1:00:00 PM	0.00	99	99	0.23	VAV	457	1.04
2:00:00 PM	0.00	100	100	0.22	VAV	479	1.04
3:00:00 PM	0.00	99	99	0.22	VAV	474	1.04
4:00:00 PM	0.00	97	97	0.24	VAV	435	1.05
5:00:00 PM	0.00	91	91	0.24	VAV	399	1.07
6:00:00 PM	0.00	75	75	0.24	VAV	337	1.09
Daily Consumption (9:00AM - 6.00PM)	0 kWh	937 kWh	$\Sigma PL_{i, \text{airside}} = 937 \text{ kWh}$			4278 kWh	

Air-cooled Chiller Plant Efficiency (kW/RT)	0.82
---	------

Air-Distribution	Total Energy Consumption (Wh)
Total	937,117

TOTAL AIR DISTRIBUTION ENERGY CONSUMPTION (kWh)	937
TOTAL AIR DISTRIBUTION EFFICIENCY (kW/RT)	0.23

(b) Unitary/ Split Conditioners System

- Average Hourly Cooling Load ($RT_{weighted}$)
- Hourly weighted COP ($COP_{weighted}$)
- Total airside power input: Assume maximum load conditions without diversity (unless simulated through modeling)

Hours	Unitary/ Split Conditioners System				
	Average Hourly Simulated Cooling Load (RT)	Hourly weighted COP	Total Condensing Units and Indoor Units Power Input	Unitary/ Split System Efficiency (kW/RT)	Unitary/ Split System Configuration
9:00AM	200	4.9	144	0.72	200RT x1
10:00AM	350	4.82	255	0.73	200RT x2
11:00AM	350	4.82	255	0.73	200RT x2
12:00PM	350	4.82	255	0.73	200RT x2
1:00PM	350	4.82	255	0.73	200RT x2
2:00PM	350	4.82	255	0.73	200RT x2
3:00PM	350	4.82	255	0.73	200RT x2
4:00PM	350	4.82	255	0.73	200RT x2
5:00PM	350	4.82	255	0.73	200RT x2
6:00PM	350	4.82	255	0.73	200RT x2
7:00PM	150	4.71	112	0.75	200RT x1
8:00PM	150	4.71	112	0.75	200RT x1
9:00PM	150	4.71	112	0.75	200RT x1
10:00PM	150	4.71	112	0.75	200RT x1
Daily Consumption (9:00AM - 6:00PM)	3950 RTH		2890 kWh	kWH/RTH = 0.73 kW/RT	

Hours	Air-Distribution System			Total System	
	Total Air Distribution Motor Input Power (kW)	Air Distribution System Efficiency (kW/RT)	Air Distribution Configuration (FCU, Others ...)	Total Power Input of AC System, (kW)	Total Efficiency (kW/RT)
9:00AM	32	0.16	FCU	176	0.88
10:00AM	60	0.17	FCU	315	0.90
11:00AM	60	0.17	FCU	315	0.90
12:00PM	60	0.17	FCU	315	0.90
1:00PM	60	0.17	FCU	315	0.90
2:00PM	60	0.17	FCU	315	0.90
3:00PM	60	0.17	FCU	315	0.90
4:00PM	60	0.17	FCU	315	0.90
5:00PM	60	0.17	FCU	315	0.90

6:00PM	60	0.17	FCU	315	0.90
7:00PM	24	0.16	FCU	136	0.91
8:00PM	24	0.16	FCU	136	0.91
9:00PM	24	0.16	FCU	136	0.91
10:00PM	24	0.16	FCU	136	0.91
Daily Consumption (9:00AM - 6.00PM)	664 kWh			3,554 kWh	

Unitary/ Split System Efficiency (kW/RT)	0.73
--	------

Air-Distribution	Total Energy Consumption (Wh)
Total	663,500

TOTAL AIR DISTRIBUTION ENERGY CONSUMPTION (kWh)	663.5
TOTAL AIR DISTRIBUTION EFFICIENCY (kW/RT)	0.17

(c) Water Cooled Chilled Water System

Using the Energy Performance Points Calculator, the following inputs are given to determine the DSE – kW/RT of the water cooled system:

- Average Cooling Load
- Chiller Power input (P_{CH})
- Chilled & Condenser water Pump Power (P_{CHWP} & P_{CWP})
- Cooling Tower Power (P_{CT})
- Total Constant flow (CF) or Variable Flow (VF) Motor Input Power (*the total hourly motor input power is based on the aggregate of all constant or variable flow fans operating at this hour. For Variable Fan flow, Part load fan power calculator may be referenced from ASHRAE 90.1, Table G3.1.3.15 - Part-Load Performance for VAV Fan Systems or Part-Load Fan Power Equation*)

The data within the following 2 tables were extracted from the Calculator:

Hrs	Water Cooled Chiller Plant							
	Daily Avg. Cooling Load (RT)	P_{CH} (kW)	P_{CHWP} (kW)	P_{CWP} (kW)	P_{CT} (kW)	Chiller Plant Total Power (kW)	Chiller Plant (kW/RT)	Chiller configuration
9:00:00 AM	1,444	760	46	95	43	943	0.65	700 RT x 3 nos.
10:00:00 AM	1,395	734	43	95	42	913	0.65	700 RT x 3 nos.
11:00:00 AM	1,801	941	71	95	54	1160	0.64	700 RT x 3 nos.
12:00:00 PM	1,790	935	70	95	54	1153	0.64	700 RT x 3 nos.
1:00:00 PM	1,749	907	67	95	52	1120	0.64	700 RT x 3 nos.
2:00:00 PM	1,836	959	74	95	55	1182	0.64	700 RT x 3 nos.
3:00:00 PM	1,816	949	72	95	54	1170	0.64	700 RT x 3 nos.

4:00:00 PM	1,654	857	60	95	50	1061	0.64	700 RT x 3 nos.
5:00:00 PM	1,493	786	49	95	45	974	0.65	700 RT x 3 nos.
6:00:00 PM	1,237	674	3	95	3	840	0.68	700 RT x 2 nos.
Daily Consumption (9:00AM - 6.00PM)	$\Sigma CL_i = 16,215$ RTh	8,501 kWh	585 kWh	948 kWh	486 kWh	10,517 kWh	kWh/RTh = 0.65 kW/RT	

Hrs	Air-Distribution System					Total System	
	Air-Side CF (kW)	Air-Side VF (kW)	Total Air-side (kW)	Air Distribution (kW/RT)	Air Distribution Configuration	Total AIR +WATER (kW)	Total air +water (kW/RT)
9:00:00 AM	0	353	353	0.24	AHU-VAV	1,296	0.90
10:00:00 AM	0	341	341	0.24	AHU-VAV	1,254	0.90
11:00:00 AM	0	401	401	0.22	AHU-VAV	1,561	0.87
12:00:00 PM	0	406	406	0.23	AHU-VAV	1,559	0.87
1:00:00 PM	0	397	397	0.23	AHU-VAV	1,517	0.87
2:00:00 PM	0	400	400	0.22	AHU-VAV	1,582	0.86
3:00:00 PM	0	396	396	0.22	AHU-VAV	1,566	0.86
4:00:00 PM	0	389	389	0.24	AHU-VAV	1,450	0.88
5:00:00 PM	0	365	365	0.24	AHU-VAV	1,339	0.90
6:00:00 PM	0	302	302	0.24	AHU-VAV	1,142	0.92
Daily Consumption (9:00AM - 6.00PM)	0 kWh	3,748 kWh	3,748 kWh			14,226 kWh	

Continued from the previous table:

Water-cooled Chiller Plant efficiency (kW/RT)	0.65
---	------

Air-Distribution	Total Energy Consumption (Wh)
Total	3,748,470

TOTAL AIR DISTRIBUTION ENERGY CONSUMPTION (kWh)	3,748
TOTAL AIR DISTRIBUTION EFFICIENCY (KW/RT)	0.23

Summary

Based on the above information, the Energy Performance Points Calculator will generate the Total System Efficiency and point score.

System	Total RTh	Chiller Plant System/ Unitary System Efficiency (kW/RT)	Air Distribution System Efficiency (kW/RT)	Total Air Conditioning System Efficiency (kW/RT)
Water Cooled Chilled Water Plant	16215	0.65	0.23	0.88
Air Cooled Chilled Water Plant	4054	0.82	0.23	1.06
Unitary System	3950	0.73	0.17	0.90
TOTAL	24,218	0.69	0.22	0.91

Total Daily Cooling Consumption (RTH)	AC System Type	Reference Total System Efficiency (Including Air Distribution kW/RT)
24218	Combination of System	0.98
% Improvement In AC Efficiency		6.89
POINTS SCORED FOR 2.1a		1.38

Example 2: A building is served by a DCS plant commissioned after Oct 2016. Thus, the DCS plant is under Path A.

Use the Energy Performance Points Calculator to select the correct mode of DCS supply.

Is this project using chilled water supplied from a DCS (regardless gazetted or non-gazetted)? [Please choose from drop-down list.]	Yes Path A	Please insert DCS efficiency information in Cell G8. Cell G7 is optional, if available for information. Ignore cells input for Chiller plant system from cell D40 to J63. Hourly RT inputs are still required for cell C31 to C54.
--	-------------------	--

Obtain District Cooling system (DCS) plant efficiency (kW/RT) provided by DCS suppliers. In this example the DCS plant efficiency is 0.65kW/RT.

Please key in info for DCS below (To be obtained from the DCS provider)		
Average daily cooling load demand from DCS	17,538.24	RTh for one day
Average total power input from DCS (including secondary/distribution pumps, input only if available)	0	kWh/day
Average DCS plant efficiency (To obtain report from DCS Supplier)	0.65	kW/RT

Key in the air-side information for the Customer building (same as the steps for air-side computation for other types of air-conditioning systems). The total efficiency of the air distribution system combined with the DCS plant can thus be obtained, and the points derived.

If the plant were commissioned before Oct 2016, it would be under Path B. In this case, the airside efficiency is used for points scoring against a baseline of 0.28 kW/RT.

2.1b Lighting System Efficiency

Documentation Requirements

(A) Design Stage

- Completed Energy Performance Points Calculator
- As per *P.5 Lighting Efficiency and Controls*

(B) Verification Stage 1

- Energy Performance Points Calculator reflecting as-built information
- As per *P.5 Lighting Efficiency and Controls*

Worked Example

Step 1: Using the Energy Performance Points Calculator, the following inputs for a particular building are given to determine the percentage improvement in the lighting performance from code:

- Area of the various spaces within the project
- Total power consumption based on the lighting layout design for each area and lighting fitting type used

Description	Areas (m ²)	Design Data		SS 530 : 2014 Requirements	
		Total Power Consumption (by area) (W)	Design Lighting Power Budget (W/m ²)	Reference Lighting Power Budget (W/m ²)	Reference Total Power Consumption (by area) (W)
Office, Work and Study					
Open Office 1	1,500	11,205	7.47	12.00	18,000.00
Meeting Rooms	100	728	7.92	12.00	1,200.00
Transport and Goods					
Corridors	500	3,048	6.10	7.00	3,500.00
Stairs, Escalators, Travellators	300	1,600	5.33	6.00	1,800.00
Lift Lobbies	500	3,548	7.10	7.00	3,500.00
Rest, Clean, Exercise and Play					
Toilets	150	1,500	10.00	10.00	1,500.00
Manufacturing & Maintenance					
Mechanical & Electrical Rooms	150	1,500	10.00	10.00	,1500.00
Other					
Open Office 2	1,500	11,205	7.47	12	18,000.00
TOTAL	4,700	34,334	7.32	10.43	49,000
Annual Consumption (kWh/yr)		98,195.24			140,140

% IMPROVEMENT OVER REFERENCE	29.9%
POINTS SCORED FOR 2.1(b)	2.99

Step 2: If the project is using any lighting control strategy then input the relevant details in the lighting control strategy table under lighting Power Budget Tab in the Energy Performance Calculator.

In this example, assume the perimeters of the open offices 1 and 2 are installed with automatic daylight responsive controls while the 5 meeting rooms' lights are installed with partial-on occupant sensing controls. Each occupancy sensor controls an area of 10m².

Control strategy and Area [Select from drop-down list]	No. Fittings	Total Power per Fitting (W)	Power Adjustment Factor	SAVINGS (W)	Annual SAVINGS kWh/yr
Automatic daylight responsive control	65	28	0.03	54.6	156.16
Partial-on occupant sensing control	26	28	0.15	109.2	312.31
			Total	163.80	468.47

Step 3: The additional savings achieved from lighting controls is not considered for points computation for 2.1b. However, it will be reflected in the building energy tab and can contribute to the points under 2.1e.

Energy Use	Notional Building Electricity (kWh/Yr)	Proposed Building Electricity (kWh/yr)	% Savings	% of Proposed Consumption
Air Conditioning System	-	-	-	0.0%
Lighting	140,140.00	97,726.77	30.3%	100.0%
Mechanical Ventilation	-	-	-	0.0%
Vertical Transportation	-	-	-	0.0%
Hot Water Generation	-	-	-	0.0%
Energy efficient Features	-	-	-	0.0%
Others [please specify]			-	0.0%
Service Equipment	-	-	-	0.0%
Common area cooling	-	-	-	0.0%
Common area cooling (Applicable only for Retail Int Corridors and Retail Atrium)	-	-	-	0.0%
BASE BUILDING	140,140.00	97,726.77		

2.1c Carpark System Efficiency

Documentation Requirements

(A) Design Stage

- Completed Energy Performance Points Calculator
- Carpark drawings showing the parking layout and any loading bays
- The lighting power density calculation and supporting documentation including schedules, layouts, data sheets and lux level simulations
- Mechanical ventilation schematics, data sheets, airflow simulations and calculations
- Mechanical ventilation control strategies

(B) Verification Stage 1

- Energy Performance Points Calculator reflecting as-built information
- As-built drawings of the carpark including the mechanical and electrical schedules, relevant data sheets
- **Purchase Orders (POs) or Delivery Orders (DOs)** of the installed systems
- On-site lux level measurements

Worked Example

Step 1: Determine Ventilation System Energy

Based on the contractor/ supplier's specification kindly input the MV Fan Schedule into the Energy Performance Points Calculator. The Energy Performance Points Calculator will generate the Design and Reference case fan efficiency.

MV Fan Schedule

Location	Area Served	Label	Floor Area (m ²)	Space Height (m)	ACH	Air Flow Rate (CMH)	*Designed Flow Rate of the Selected Motor Fan (CMH)	External Static (Pa)	#Motor Nameplate Power (W)	#Motor Input Power (W)
e.g. B1	e.g. Carpark for office	MVB1-1	13,612	2.5	5	170,150	170,150		40,000	39,000

Continued for MVB1-1

Option 1 - Nameplate Power			Option 2 - Input Power			
Design Fan Efficiency (W/CMH)	Reference Fan Efficiency (W/CMH)	Reference Nameplate power (W)	Design Fan Efficiency (W/CMH)	Reference Fan Efficiency (W/CMH)	Reference Input power (W)	PD (Pa)
0.235	0.350	59,552.500	0.229	0.300	51,045.000	

Total Airflow Rate (CMH)	170,150.00
Total Reference Nameplate Power (kW)	59.55
Total Design Nameplate Power (kW)	40.00
Savings (kW)	19.55

Step 2: Determine the lighting system energy performance

Based on contractor/ supplier's specification kindly input the lighting schedule into the Energy Performance Points Calculator:

Description	Areas (m ²)	Design Data		SS 530 : 2014 Requirements	
		Total Power Consumption (by area) (W)	Design Lighting Power Budget (W/m ²)	Reference Lighting Power Budget (W/m ²)	Reference Total Power Consumption (by area) (W)
Carpark	13,612	25,000	1.84	3	40,836
Loading Docks	0	0	0.00	0	0
TOTAL		25,000			40,836
% IMPROVEMENT OVER REFERENCE		38.8%			

Step 3: Determine % improvement and points scored

Based on the information provided at Steps 1 and 2. The Energy Performance Points Calculator will be able to generate the total energy of the building's carpark systems and points score.

Energy Use	Notional Car Park Electricity (kWh/yr)	Proposed Car Park Electricity (kWh/yr)	% Savings
Lighting	116,791	71,500	38.8%
Mechanical Ventilation	170,320	114,400	32.8%
Air Conditioning	-	-	-
Receptacle	-	-	-
TOTAL	287,111	185,900	
PROPOSED IMPROVEMENT (kWh/yr)		101,211	
% IMPROVEMENT		35.3%	
POINTS SCORED FOR 2.1c		1.76 points	

2.1d Receptacle Load Efficiency

Documentation Requirements

(A) Design Stage

- Completed Energy Performance Points Calculator
- Commitment to procure/ evidence of procurement of energy efficient receptacle equipment
- Technical specifications of receptacle equipment
- Provision of separate sub-metering for receptacle load or separate electrical circuit for receptacle load to facilitate measurement during operation. The sub-meters provided are to be linked with BMS.
- The energy associated with each equipment shall be calculated and a W/m² value derived. Guideline figures are listed in the Energy Performance Points Calculator and can be used
- Baselines: For refrigerators or other NEA tick-labelled systems the baseline shall be a 1 tick system. For process loads, they shall be compared to the industry norm and savings shall be justified through empirical evidence

(B) Verification Stage 1

- Energy Performance Points Calculator reflecting as-built information
- Purchase Orders (POs) or Delivery Orders (DOs) of the installed systems
- Onsite logged measurements or sub metered readings of receptacle load

2.1e Building Energy

Documentation Requirements

(A) Design Stage

- Completed Energy Performance Points Calculator
- Technical specifications and product information of all energy related systems

(B) Verification Stage 1

- Energy Performance Points Calculator reflecting as-built information
- As-built equipment, spatial schedules and relevant drawings, schematics
- Equipment Delivery Orders (DOs) or Purchase Orders (POs)

Option 2: Performance-Based Computation

Guidance Notes

The option will be computed based on performance of respective systems and would not require Energy Performance Points Calculator for computation.

2.1f Space Conditioning Performance

Documentation Requirements

A) Design Stage

- A plan to show the declared mode of ventilation for each space and compute the % for each mode of ventilation based on occupant areas.
- For naturally ventilated areas, it will be based on the plan and computation mentioned above and the scoring for section 1.3c will be added on.
- For mechanically ventilated areas, project team shall submit catalogues and details of intended mechanical fan systems.
- For air-conditioned areas, documents required as per *P.4 Air Conditioning Total System and Component Efficiency*. All projects shall submit air distribution information.
- For computation of fan power, 5% driver loss needs to be accounted for the use of VSD. Project team can use lower value if they can substantiate VSD loss with documentation.

(B) Verification Stage 1

- For naturally ventilated areas, update of the mode of ventilation for various spaces based on as-built, if necessary.
- For mechanically ventilated areas, Purchase Orders (POs) or Delivery Orders (DOs) of respective mechanical ventilation equipment.
- As per *P.4 Air Conditioning Total System and Component Efficiency*. All projects shall submit air distribution information.

Worked Example

Please see example 2.1a. Peak load occurs at 2pm.

Hrs	Air-Cooled Chiller Plant System			Air-Distribution System		Total System	
	Daily Avg. Cooling Load (RT)	Chiller Plant Total Power (kW) [$P_{CH} + P_{CHWP}$]	Chiller Plant (kW/RT)	Total Air Distribution Power (kW)	Air Distribution Efficiency (kW/RT)	Total Airside + Chilled-Water Systems Power (kW)	Total Air + Chilled-Water System Efficiency (kW/RT)
2:00 PM	459	379 [360+19]	0.83	100	0.22	479	1.044

Hrs	Water-cooled Chiller Plant System			Air-Distribution System		Total System	
	Daily Avg. Cooling Load (RT)	Chiller Plant Total Power (kW) [$P_{CH} + P_{CHWP} + P_{CWP} + P_{CT}$]	Chiller Plant (kW/RT)	Total Air Distribution Power (kW)	Air Distribution Efficiency (kW/RT)	Total Airside + Chilled-Water Systems Power (kW)	Total Air + Chilled-Water System Efficiency (kW/RT)
2:00 PM	1,836	1182 [959 + 74 + 95 + 55]	0.64	400	0.22	1,582	0.862

Hours	Unitary/ Split Conditioners System				
	Average Hourly Simulated Cooling Load (RT)	Hourly weighted COP	Total Condensing Units and Indoor Units Power Input (kW)	Unitary/ Split System Efficiency (kW/RT)	Unitary/ Split System Configuration
2:00PM	350	4.82	255	0.728	200RT x2

Peak Cooling Load	AC System Type	Total Power (kW)	Combined Total System Efficiency (Including Air Distribution) kW/RT	Reference Total System Efficiency (Including Air Distribution) kW/RT	% Improvement In AC Efficiency	POINTS SCORED FOR 2.1 a
459	Air-Cooled Chiller Plant System	479	1.044	Breakdown		
1,836	Water-cooled Chiller Plant System	1,582	0.862			
350	Unitary/ Split Conditioners System	255	0.728			
2645	Combination of System	2316	0.875			

2.1g Lighting System Efficiency

Documentation Requirements

(A) Design Stage

- As per *P.5 Lighting Efficiency and Controls*

(B) Verification Stage 1

- As per *P.5 Lighting Efficiency and Controls*

Worked Example

Please see example 2.2a (pls include carpark lighting if applicable).

% IMPROVEMENT OVER REFERENCE	29.9%
POINTS SCORED FOR 2.1 (b)	5.08

2.1h Building Systems Performance

(i) Receptacle Load Efficiency

Documentation Requirements

(A) Design Stage

- As per 2.1d with computation update with/without the use of Energy Performance Points Calculator

(B) Verification Stage 1

- As per 2.1d with computation update with/without the use of Energy Performance Points Calculator

Worked Example

- A mixed office and retail development was designed to meet 13W/m² for receptacle in office areas. 70% of the floor area belongs to the office. The proposed receptacle load has 18.75% improvement from baseline of 16W/m² for office areas.
- Point scored = $0.05 \times 18.75 \times 70\%$
= 0.66 points

(ii) Car Park Ventilation Energy

Documentation Requirements

(A) Design Stage

- Carpark drawings showing the parking layout and any loading bays
- Mechanical ventilation schematics, data sheets, airflow simulations and calculations.
- Mechanical ventilation control strategies

(B) Verification Stage 1

- As-built drawings of the carpark including the mechanical and electrical schedules, relevant data sheets
- Purchase Orders (POs) or Delivery Orders (DOs) of the installed systems
- On site photographs of installed systems

Worked Example

- A carpark of 10,000m² has 95% of areas in basement carparks and 5% of areas in open areas.
- For mechanical ventilated basement carpark with CO sensor, please see example 2.1c Step 1

Total Airflow Rate (CMH)	170,150.00
Total Reference Nameplate Power (kW)	59.55
Total Design Nameplate Power (kW)	40.00
Savings (kW)	19.55
% Improvement	32.83%

- Point scored = 5% of score for naturally ventilated carpark + 95% of score for mechanical ventilated carpark
= $0.05 \times 1.5 + 0.95 \times (0.015 \times 32.83 + 0.25)$
= 0.78 points

(iii) Energy Use Intensity

Documentation Requirements

(A) Design Stage

- Computation of Total Building Energy's Consumption to compute Energy Use Intensity (EUI) and compare with top 25th percentile EUI with prevailing BCA Building Energy Benchmarking Report (BEBR).

(B) Verification Stage 1

- Building's utilities bills and electrical meter readings for computation of Energy Use Intensity (EUI) with BEBR's benchmark value adopted during design stage.

(iv) Energy Efficient Practices and Features

Documentation Requirements

(A) Design Stage

- Technical specifications and product information of all energy related systems

(B) Verification Stage 1

- As-built equipment, spatial schedules and relevant drawings, schematics
- Equipment Delivery Orders (DOs) or Purchase Orders (POs)

Worked Example

A hotel building uses the following energy efficient features have a combined energy saving of 7%

- Energy efficient heat pump system to generate hot water
- Heat recovering system
- Regenerative lift
- Motion sensors for staircases and toilets

Total Building Energy Consumption = 4.4 million kWh/yr

Computation for heat pump

Heat Source Output, $Q_1 = 1,000,000\text{kWh/yr}$

Hot water recirculating Thermal Energy Loss, $Q_2 = 300,000\text{kWh/yr}$

Effective Hot Water Thermal Energy Consumption, $Q_3 = Q_1 - Q_2$

$$= 700,000\text{kWh/yr}$$

System electrical input energy = 250,000kWh/yr

$$\text{Hot Water System Ratio} = \frac{\text{Effective Hot Water Thermal Energy Consumption}}{\text{System Electrical Input Energy} - \text{Energy Recovery}} = \frac{700,000}{250,000 - 0} = 2.8$$

$$\text{Baseline energy consumption} = \frac{\text{Effective Hot Water Thermal Energy Consumption}}{1.6} = \frac{700,000}{1.6} = 437,500\text{kWh/yr}$$

Energy saving due to hot water system = 437,500kWh/yr – 250,000kWh/yr = 187,500 kWh/yr

Suppose energy saving due to other items are as follows:

Heat recovering system = 50,000kWh/yr

Regenerative lift = 50,000kWh/yr

Motion sensors = 22,000kWh/yr

Total energy saving = 309,500kWh/yr

$$\% \text{ energy saving} = \frac{309,500 \text{ kWh/yr}}{4,400,000 \text{ kWh/yr}} = 7.03\%$$

Point scored = 2 points (7% > 4% for max credit)

1 point for Additional Energy Efficient Practices and Features (Advanced Green Efforts)

2.2 Renewable Energy

2.2a Solar Energy Feasibility Study

Definitions

Building's footprint: This refers to the area on a project site used by the building structure, defined by the perimeter of the building plan. Open carpark spaces, landscape, underground construction and non-building facilities such as covered walkways are not included in the building footprint.

Documentation Requirements

(A) Design Stage

Submission of a solar feasibility report, as outlined below, acknowledged by (i) the QP/PE(Electrical) or PV specialist or Certified GM Specialists (Certified GMM, GMP) and (ii) the Developer's Project Manager.

- **Executive Summary** – A non-technical summary of the potential for solar adoption for the building, including the developer's decision on whether solar PV would be installed for the building, accompanied with appropriate justification.
- **Roof Characteristics and Shading Considerations** – description of the roof characteristics (i.e. number of roofs, roof area, and height variation of various roofs) to be provided with drawings. Any potential shading from external sources (e.g. adjacent buildings, trees, etc.) as well as internal sources from within project (e.g. M&E services, lamp posts, etc.) are to be considered and quantified. Any considerations for shading due to external factors beyond the project site area are to be supplemented with site drawings (or future development plans) that depict the estimated height of shading source.
- **Technical Solar Energy Generation Potential** – Based on the shading consideration and any site specific constraints, the following information is to be provided using the prescribed list of assumptions provided below. Any unique assumptions are to be clearly stated.
 - Expected solar capacity (in kWp) potential on the roof based on shading consideration and layout
 - Expected annual electricity generation (in kWh) based on solar capacity potential
- **Economics of Solar Installation** – Using the electricity generation potential, the economics of the solar installations are to be quantified with the following considerations:
 - Upfront costs of installation

- Expected maintenance costs
- Expected annual electricity bills based on energy consumption calculation
- Expected costs saving for generation of electricity to be consumed on site
- Expected revenue from solar electricity sold to grid (if applicable)
- Payback period/Discount rate
- **Guiding Assumptions**
 - Solar PV technologies (unshaded) with area efficiency of 0.1 kWp/m² and annual generation yield of 1,100 – 1,300 kWh/kWp can be assumed if project has not decided on the specific PV technology to be used
 - Tariff at \$0.20 per kWh for low tension rate and \$0.15 per kWh for high tension rate can be assumed if project has not have information on potential electricity tariff (Further information may be found at <http://www.solar-repository.sg/future-electricity-price-scenarios>)
- **Roof Access and Safety requirements** – Identify the access and safety measures that would have to be installed.
- **Roof Optimisation Recommendations** – Recommendations for the spatial optimisation of the roof design to facilitate including M&E equipment locations to maximise the usable roof space.
- **Acknowledgement-** Acknowledgements from QP/PE (Electrical)/ PV specialist Consultants and the Developer’s Project Manager are to be provided for the feasibility study report.

2.2b Solar Ready Roof

Documentation Requirements

(A) Design Stage

- Detailed drawings showing the relevant design features for roof readiness
- Detailed drawings or technical specifications showing the relevant provisions for roof readiness. To score for structural readiness, the structural QP shall certify that the building and roof can support any additional static and wind load imposed by future PV system

(B) Verification Stage 1

- As-built drawings and on site photographs of relevant design features and provisions for roof readiness

Worked Examples

Structural readiness

The building and roof shall be able to support any additional static and wind load imposed by the PV system. Depending on the type of roof and components of the PV installation, the static load differs. For wind load, it depends on the installation angle. In terms of roof designed to accommodate easy structural installation of solar panels, examples (non-exhaustive) are as follows:

- Metal roofs: The use of roof profiles with suitable seams that allow easy application of roof clamps, and avoid trapezoidal or corrugated profile
- Trellis: The use of trellis with 10-15° slope instead of horizontal top surface, to facilitate optimal module tilt angle
- RC roof: The provision for a solution that does not require heavy ballast to prevent modules from lifting off in strong wind. (e.g. provision of anchor points for solar support systems prior to waterproofing)

Electrical readiness

- Provision of room or sheltered space at roof level or max one level below, to accommodate inverters, circuit breakers and PV feed-in switch boards
- Correct dimensioning of enough circuit breakers for PV feed-in
- Pre-connecting PV feed-in switch boards to main AC switch board

Spatial readiness

- Shifting of shade-casting structures such as staircase doghouses, lift motor rooms, water tanks and M&E equipment away from the east-west sun path, where possible

2.2c Adoption of Renewable Energy

Documentation Requirements

(A) Design Stage

- Technical product information on the salient features of the renewable energy system and the expected renewable energy generated
- Detailed drawings showing the location and renewable energy provisions
- Calculation of the percentage replacement of electricity and the total annual electricity consumption of the development

(B) Verification Stage 1

- As-built drawings and on site photographs of the renewable energy source(s)
- Technical specifications and integration reports of the installed system(s) including total capacity installed
- Testing and commissioning report
- Logging of the energy production and calculated energy replacement rate
- Purchase orders/ delivery orders of the total capacity installed

Worked Example 1

Based on contractor/ supplier's specifications, compute the % replacement:

Description (Example)	Area Of PV Array (m ²)	kWp Installed (kWp)	Annual Yield (kWh)	Notes
Upper roof Block A	2,000	200	240,000	
Roof Block B	2,000	200	240,000	
			0	
Total		400	480,000	

Annual Replacement Rate	10.02%
Total Building Consumption (kWh)	4,788,030
EUI	158.63
Points Scored	8.02 (cap at 6 points)

Therefore, points scored under 2.2c (based on EUI > 50) = 6 points

Points scored under *Further Electricity Replacement by Renewables (Advanced Green Efforts)* = 2.02 points

3. Resource Stewardship

P.7 Water Efficient Fittings

Documentation Requirements

(A) Design Stage

- Extracts of the tender design specification showing all the water fitting provisions for the development:
- Water fitting schedules showing the numbers, types and the WELS ratings of the proposed fittings in the prescribed tabulated format shown below:

Water Fitting Type	Quantity			Applicable Areas	Total No
	3 Ticks	2 Ticks	Mandatory WELS		
Basin Taps & Mixers					
Sink Taps & Mixers					
Shower Taps & Mixers					
Dual-Flush Flushing Cisterns					
Total No. of fittings					

(B) Verification Stage 1

- As-built water fitting schedules showing the numbers, types and the WELS rating delivery order reference no, brands/ models of the installed fittings in similar tabulated format as above
- Purchase orders/ delivery orders, for the brands/models of the installed sanitary fittings to demonstrate compliance to the committed design specifications

Worked Example

Example of a hotel development where the pre-requisite has been met:

Water Fitting/ Product Type	Quantity			Applicable Areas	Delivery Order Ref No / Brand	Total No
	3 Ticks	2 Ticks	Mandatory WELS			
Basin taps & mixers	50			Public toilets	T1234/ Xbrand	480
	30			Staff toilets	T3456/ Ybrand	
		400		Other areas including hotel guestrooms	T2222/ Zbrand	
Sink taps		50		All areas	T4321/ Abrand	50
Shower taps & Mixers	20			Shower facilities at common areas (Public use)	T2343/ ZXbrand	420
			400	Hotel guestrooms	T6524/ ABbrand	
Showerheads		20		Public use	T7648/ YZbrand	420
			400	Hotel guestrooms	T2676/ XZbrand	

Dual flush Flushing Cisterns		420		All areas	T2454/ FVbrand	420
Total No. of fittings	100	890	800			1790

3.1 Water

3.1a Water Efficient Systems

(i) Landscape Irrigation

Documentation Requirements

(A) Design Stage

- Water efficient irrigation system:
 - Extracts of the tender and design specification showing the provision and details of the water efficient irrigation system
 - Relevant layout plans showing the overall landscape areas and the areas that would be served using the system
 - Calculation showing the percentage of the landscape areas that would be served using the system
- Drought tolerant plants:
 - Relevant layout plans showing the overall landscaping and areas that use drought tolerant plants
 - Calculation showing the percentage of the landscape areas that would be planted with drought tolerant plants

(B) Verification Stage 1

- Water efficient irrigation system: As-built layout plans showing the location of the water efficient irrigation systems and determine compliance with the committed design specifications
- Drought tolerant system: Purchase orders/ delivery orders for the species of drought tolerant plants and determine compliance with the committed design specifications

Worked Example

A project has 45% of the landscape areas served by automatic sub-soil drip irrigation system with rain sensor control. Thus, points scored = 0.5 point (Every 25% of landscape areas served by water efficient irrigation systems attains 0.5 point)

The other 55% of the landscape areas comprises drought tolerant plants. Thus, points scored = 1 point (Every 20% of the landscape areas with drought tolerant plants attains 0.5 point) = 1.5 points (capped at 1 point)

Total points scored under 3.1a(i) = 0.5 + 1 = 1.5 point

(ii) Water Consumption of Cooling Towers

Documentation Requirements

(A) Design Stage

- Cooling tower water treatment:
 - Technical specifications of the proposed cooling tower water treatment system, filtration system and the methodology that would enable 7 or more cycles of concentration without compromising on the water quality and operational performance
 - Relevant drawings and details showing how the cooling towers have been designed, the location of the cooling towers and other supporting systems that are required to achieve the proposed cycle of concentration where relevant
 - Maintenance regime of the proposed water treatment system and filtration systems
- Reduction of **water requirement for cooling towers:**
 - Technical and design specification of devices such as heat pumps
 - **Calculation of the expected heat recovered and potential water savings**

(B) Verification Stage 1

- Cooling tower water treatment:
 - Onsite testing reports showing the cycles of concentration achieved and maintained most of the time
 - Handover documents on maintenance regime needed for the cooling tower water treatment system and filtration system
- **Reduction of water requirement for cooling towers:**
 - Commissioning report of the heat recovery or equivalent system and the resultant reduction of heat load requirement through the cooling towers
 - **Calculation of the heat recovered and expected water savings**

Worked Example

Reduction of water requirement: A mixed development uses heat pump to **recover waste heat from condenser loop and reduce water requirement needed for cooling tower operation.** The heat pump has a heating capacity of 430.6 kW at the condenser water loop as the heat source. The manufacturer's technical data sheet is as follows:

DESIGN PERFORMANCE												
Capacity (kW)	Input Power (kW)	Performance (COP)	Heating (kW)	Cooling (kW)	Evaporator				Condenser			
					P.D. (kPa)	T in (°C)	T out (°C)	Flow (l/s)	P.D. (kPa)	T in (°C)	T out (°C)	Flow (l/s)
430.6	86.1	5.0	430.6	344.2	28.6	35.0	29.0	13.7	37.4	55.0	65.0	10.3

The water savings shall thus have to be calculated to score the point.

Based on the fundamental principle $Q = m \times h$

Where

Q : Evaporation heat (kJ/kg)

H : Evaporation heat (kJ/kg) 2257 @atmospheric pressure

m : Mass of water (kg)

Water saving in Volume $V = \text{Mass} / \text{Density}$

Assuming the estimated total heat load requirement of this particular development for one whole day to be 2,580 kWh, we can then derive it to be equivalent to about 6 hours of operation of the heat pump by dividing it over the heat capacity of 430.6 kW.

Based on the technical data sheet, the heat pump has a cooling capacity of 344.2 kW which is the heat source that can be harvested from the condenser water loop. In other words, this will be the reduction in **heat required to be removed through the cooling towers** or the amount of heat that is diverted from cooling towers.

Total heat source harvested per day = 344 kW x 6 hours = 2,064 kWh = 7,430,400 kJ

Mass of water $m = Q/h = 7,430,400 / 2,257 = 3,293$ kg

Volume of water = Mass / Density = 3,292 kg / 995.7 kg/m³ = 3.3 m³ which is 3,300 L of water per day.

(Note: The heat source of heat pumps can typically be harvested from the chilled water loop or condenser water loop. Please also note that the density of water is different for different temperatures. For example, for chilled water loop, water temperature is approximately 10 – 15°C, thus the water density value between 998.2 – 999.7 kg/m³ should be used in the computation. Similarly, for condenser water loop where water temperature is approximately 30-35°C, the water density value between 992.2 – 995.7 kg/m³ should be used.)

From the calculation, the project can save 3,300 L/day of water if a heat pump is used to harvest the heat source from condenser water loop.

Better Water Efficient Fittings (Advanced Green Effort)

Documentation Requirements

(A) Design Stage

- Extracts of tender design specifications showing all the water fitting provisions for the development
- Water fitting schedules showing the numbers, types and the selected WELS rating of all proposed fittings in the prescribed tabulated format as P.7 which includes those fittings that are subject to mandatory standards stipulated in the *Singapore Standard CP 48- Code of Practice for Water Services*

(B) Verification Stage 1

- As-built water fitting schedules showing the number, brand/model no, types and the WELS rating of all installed fittings in the prescribed tabulated format as P.7

3.1b Water Usage Monitoring

(i) Water Monitoring and Leak Detection

Guidance Notes

Common major water uses for building type where private meters should be installed to monitor the amount of water used area are as listed:

Building Type	Major Water Uses
Hotels	<ul style="list-style-type: none"> • Guestrooms • Cooling towers* • Food and beverage outlets • Production kitchen • Laundry • Cold water supply inlet to hot water supply or boiler • Swimming pool • Spa & gym
Institutional Buildings (IHL, prison, military or defence installations)	<ul style="list-style-type: none"> • Cooling towers* • Toilets for each block • Washing areas • Swimming pool • Food and beverage outlets / kitchens)
Hospitals	<ul style="list-style-type: none"> • Cooling towers* • Toilets, wards and operating theatres for each block • Kitchen • Cold water supply inlet to hot water supply or boiler
Sports and Recreational Facilities and Tourist Attractions	<ul style="list-style-type: none"> • Cooling towers* • Exhibits or enclosures • Washing areas • Toilets • Food and beverage outlets • Irrigation • Swimming pools
Office or Retail Buildings (or any other building types that are not specifically stated)	<ul style="list-style-type: none"> • Cooling towers* • Toilets • Pantries • Food and beverage outlets • Production and processes

Note: For cooling towers, make-up water meters are to be provided to monitor water loss due to evaporation, drift and blow down during cooling tower operation.

Documentation Requirements

(A) Design Stage

- Private meters:
 - Extracts of tender specification stating the provision of water metering for all major water uses as outlined in the *Guidance Notes*
 - Schematic drawings of cold water distribution system showing the location of the private water metering provided
- Remote metering system:
 - Extracts of tender specification stating the provision of remote metering system
 - Schematic drawings showing the location of remote metering system, how it connects to the building management system and highlights of the specific alert features to detect water leakages

(B) Verification Stage

- Private meters: As-built schematic drawings of the water distribution system showing the location of the private water metering provided
- Remote metering system:
 - As-built schematic drawings showing the location of the remote metering system
 - Screenshots of the BMS system integration and the water leak detection alert settings

(ii) Water Usage Portal and Dashboard

Documentation Requirements

(A) Design Stage

- Specifications of the water usage portal, dashboard or other equivalent forms and relevant parameters such as areas, occupancy areas or use type that are to be included for monitoring and setting of water consumption targets.
- The data acquisition system, typically a building management system (BMS), must be able to store the measured data for at least 36 months, and to create reports showing minimally monthly, and annual water consumption associated with each meter with option to export data.
- For the display of 50th percentile line based on operating hours, data can be displayed based on weekly or monthly information of individual tenant/space. As a good practice, the inclusion of 25th and 75th percentile line will help occupants to understand their consumption performance better.
- Plans and schematics to illustrate:
 - Location and means of access of the portal
 - Single line diagram of the water sub-metering scheme and links to a BMS or equivalent system

(B) Verification Stage

- Photographic evidences of the installed water usage portal or dashboard or equivalent form displaying metered water data by area or use and other relevant parameters as well as trending and water benchmark.

3.1c Alternative Water Sources

Guidance Notes

Rainwater harvesting: The minimum rainwater harvesting capacity required is to be based on (i) the demands for rainwater use using relevant parameters such as no. of occupants, water usage frequency or irrigation needs or (ii) the collection area and precipitation using the following formula:

$$\text{Volume} = \text{Roof Area} \times \text{Precipitation} \times \text{Efficiency}$$

where

Volume (litres): Amount of rain that can potentially be harvested in that time period.

Roof Area (m²): Collection area. For slope, curved, pitch roof or similar form, projected areas can be used.

Precipitation (mm): Amount of rainfall in that time period. Average mean daily rainfall derived from the latest annual total rainfall and annual mean raindays published by Meteorological Services Singapore is to be used in computation.

Efficiency (%): Percentage of water that could be captured, as opposed to splashing out of the system somewhere and it is assumed to be 90% for simplicity.

Documentation Requirements

(A) Design Stage

- AHU condensate collection: Schematic drawings and calculation of the AHU condensate collection
- NEWater supply: Schematic drawings showing NEWater supply
- On-site recycled water: Schematic drawings and detailed system for on-site recycled water such as greywater recycling
- Rainwater harvesting: Computation of minimum rainwater harvesting capacity required, layouts showing the location of rainwater harvesting tank, the volume of the tank, the catchment area and area of usages

(B) Verification Stage 1

- As-built schematic drawings and photographs of the water recycling systems during and after installation where applicable

3.2 Materials

3.2a Sustainable Construction

(i) Conservation and Resource Recovery

Documentation Requirements

(A) Design Stage

- Conservation permit and supporting documents if applicable
- Pre-demolition assessment records of demolition site showing clear recovery/ recycling targets and estimated quantities of salvageable materials
- Method statement detailing how sequential demolition is to be carried out
- Waste management plans such as plan layout showing locations of recycling bins for collection and storage of different recyclable waste, records of waste movement from site to recycling facilities, proposed usage of the various types of recovered waste

- Details of best practice pollution prevention policies and procedures at construction and demolition sites

(B) Verification Stage 1

- Detailed records of the volume of waste sent to the relevant approved recyclers

(ii) Resource Efficient Building Design

Definitions

Concrete Usage Index (CUI): CUI is defined as the volume of concrete in cubic meters needed to cast a square meter of constructed floor area (CFA):

$$\text{Concrete Usage Index} = \text{Concrete Volume in } m^3 / \text{CFA in } m^2$$

CUI serves as an indicator of the amount of concrete used to construct the superstructure that includes both the structural and non-structural elements. CUI does not include the concrete used for external works and sub-structure works such as basements and foundations.

Documentation Requirements

(A) Design Stage

- Calculation showing the quantity of concrete for each floor level which should include all the concrete building elements, such as non-load bearing and architectural concrete components
- BIM model (if applicable), architectural and structural plan layout, elevation and sectional plans showing the type of building elements/ systems used, the dimensions and sizes of all the building and structural elements
- Technical product information (including drawings and supporting documents) of the building systems
- Calculations of the use of alternative construction methods supported by detailed design drawings

(B) Verification Stage 1

- As-built drawings

Worked Example

Concrete Usage Index

Proposed development comprises a 30 storey block with a basement carpark and the following details:

Project Gross Floor Area (GFA) = 60,000m². Superstructure elements are all precast.

The concrete usage index for foundation and basement carpark works are excluded in CUI tabulation.

Computation Of Concrete Usage Index				
Project Reference No.: AXXXX-00001-20XX			Total no. of storey for the project: 30	
Block No: A				
	Structural System	Thickness (mm) or size (mm x mm)	Volume of concrete (m ³)	Remark *
1	1st storey			
	1.1 Columns	300x300, 400x400	120	57 nos of C80 300x300 precast columns
	1.2 Beams	300x500, 200x500	320	Precast
	1.3 Slabs	200,225,250	400	Post-tensioned (Total floor area = 1,600 m ²)

	1.4 Staircases	175	93.5	Precast
	1.5 Suspended structures like planter boxes, bay windows, ledges etc	-	0	-
	1.6 Parapets	-	0	-
	1.7 External walls - loadbearing walls	-	0	-
	1.8 External walls – non-loadbearing walls	125	22	Precast green wall (wall area = 176 m ²)
	1.9 Internal walls – loadbearing walls	200	55	RC (wall area = 275 m ²)
	1.10 Internal walls –nonloadbearing walls	100	10	Light weight concrete (wall area = 100 m ²)
	1.11 Others (kerbs, ramps, services risers, etc)	-	15	RC
	Total volume of concrete for this storey (m ³)			1,035.5
	Total constructed floor area for this storey (m ²)			2,200
2	Typical storey (2nd to roof)			
	1.1 Columns	300x300, 400x400	115	Precast
	1.2 Beams	300x500, 200x500	301.5	Precast
	1.3 Slabs	200,225,250	320	Post-tensioned (Total floor area = 1,280 m ² per floor)
	1.4 Staircases	175	93.5	Precast
	1.5 Suspended structures like planter boxes, bay windows, ledges etc	-	0	-
	1.6 Parapets	-	0	-
	1.7 External walls - loadbearing walls	-	0	-
	1.8 External walls –non-loadbearing walls	125	22	Precast green wall (wall area = 176 m ²)
	1.9 Internal walls – loadbearing walls	200	50	RC (wall area =250m ²)
	1.10 Internal walls – nonloadbearing walls	100	10	Light weight concrete (wall area = 100 m ²)
	1.11 Others (kerbs, ramps, services risers, etc)	-	0	RC
	Total no. of columns			313
	Total volume of concrete for one storey (m ³)			912
	Total constructed floor area for one storey (m ²)			1,926.6
	Total volume of concrete for 2nd to 30th storey – includes roof level (m ³)			27,360
	Total constructed floor area for 2nd to 30th storey – includes roof level (m ²)			57,798
	Total volume of superstructure concrete for this project (m³)			28,095.5
	Total constructed floor area of superstructure for this project (m²)			59,998
	Concrete Usage Index (CUI in m³/m²)			0.473

*To indicate if the structural elements is of precast concrete, post-tensioned concrete, high strength concrete (>Grade 60) or reinforced concrete (RC) under the 'Remarks' column.

Concrete usage for the superstructure	Constructed floor areas
1st storey = 1,035.5 m ³ From 2nd to 30th storey = 27,360 m ³ (including roof level)	1st storey = 2,200 m ² From 2nd to 30th storey = 57,798 m ² (including roof level)
Therefore,	Therefore,

Total concrete usage = 28,395.5 m ³	Total constructed floor areas = 59,998m ²
--	--

Important notes: The quantities of the concrete for all the structural and non-structural elements for each floor level are to be computed. All the elements listed in the table such as columns, beams, slabs, suspended structures (like planter boxes, bay windows and ledges etc.), parapets, walls and others (service risers, kerbs, ramps etc.) are to be included. The derivation of the concrete volume breakdown must be traceable on the drawings. The concrete usages for foundation and basement works are to be excluded in CUI computation. For project with raft foundation that is also the floor slab of 1st level, half of the volume will be accountable in the CUI calculation.

Based on the point allocation shown in Table 1 of 3.2a(ii), CUI of $0.47 \text{ m}^3/\text{m}^2 \leq 0.50 \text{ m}^3/\text{m}^2$.

Therefore, points scored = 1 point

Sustainable Building Systems

Adoption rate of recognised building systems for the example is as determined below:

Building element	Coverage based on area on plan
Post-tensioned Slabs	40,000 m ²
High Strength Concrete Columns	$57 \times 0.3 \times 0.3 = 5.13 \text{ m}^2$
Composite steel Beams	1,000 m ²
Lightweight concrete Walls	1,000 m ²
Precast green walls	2000 m ²
Total Area	43,005 m²

**Note: Assumes no overlaps in the area of coverage on plan. Alternatively, area of coverage can be directly taken off from the plan drawing instead of a tabular calculation as above.*

From the CUI tabulation, CFA = 59,998 m²

% coverage by area = $71.7\% < 75\%$

Therefore, points awarded = 1 point.

Therefore, points scored for this sub-section = $1.0 + 1.0 = 2.0$ points

Use of BIM to Calculate CUI (Advanced Green Efforts)

Documentation Requirements

(A) Design Stage

- Printout of calculations from BIM software showing the quantity of concrete for each floor level which should include all the concrete building elements, such as non-load bearing and architectural concrete components
- BIM model, architectural and structural plan layout, elevation and sectional plans showing the type of building elements/ systems used, the dimensions and sizes of all the building and structural elements
- Printout of calculations from BIM software showing the use of alternative construction methods supported by BIM drawings

(B) Verification Stage 1

- As-built BIM model

(iii) Low Carbon Concrete

Documentation Requirements

(A) Design Stage

- Extract of tender specification or proposed concrete mix design showing the maximum clinker content and/or the detailed usage of recycled/ engineered aggregates (e.g. RCA/WCS)
- Calculation showing the quantity of recycled/ engineered aggregates (e.g. RCA/WCS) to be used for the project
- SGBC certification of the concrete products/mixes used for the project

(B) Verification Stage 1

- As-built drawings highlighting if there is deviation of the building design or usage scope clinkers/ engineered aggregates (e.g. RCA/ WCS) in the project.
- Delivery orders and details of the actual concrete mix used in the project showing the usage of clinkers/ engineered aggregates (e.g. RCA/ WCS)
- SGBC certification of the concrete products/mixes used for the project

Worked Example

Proposed development comprises a 30-sty block with a basement carpark as per example for *Concrete Usage Index*.

Clinker content

Two types of Grade 40 Concrete were used for the project:

Type 1 concrete: The total cementitious mix specified is 370 kg/m³ of cement by mass. 20% of the cementitious mix was replaced by GGBS. Based on Table 1 of *SS EN 197-1*, the cement used for the project is classified as CEM2.

Clinker content of this concrete = $0.8 \times 370 \text{ kg/m}^3 = 296 \text{ kg/m}^3 < 400 \text{ kg/m}^3$.

Extent of use of concrete (by volume) = 40%

The concrete was not certified by SGBC.

Type 2 concrete: The concrete was certified by SGBC with 2-ticks rating (deemed to meet requirement of clinker content $< 400 \text{ kg/m}^3$).

Extent of use of concrete (by volume) = 60%

Total concrete coverage (Type 1 and Type 2 by volume) that had clinker content $\leq 400 \text{ kg/m}^3$ for the super-structure = 100%. Therefore, points scored = 0.5 points. Extra points cannot be scored for certified concrete as not all concrete used is certified.

Replacement of coarse and fine aggregates

The project uses 10% replacement of coarse aggregate with RCA and 5% replacement of fine aggregate with WCS for all slabs, and 30% replacement of coarse aggregate with RCA for all non-load bearing walls in the superstructure.

RCA

Minimum usage requirement for RCA = $0.015 \times \text{GFA} = 0.015 \times 60,000 = 900$ tons

Total concrete volume of all slabs = $400 \text{ m}^3 + 320 \text{ m}^3 \times 30 = 10,000 \text{ m}^3$

Total concrete volume of all non-load bearing walls = $22 \text{ m}^3 + 10 \text{ m}^3 + (22 \text{ m}^3 \times 30) = 1,652 \text{ m}^3$

[Approximate coarse aggregate content in concrete = 1 ton/m^3]

Total tonnage of RCA used for super structure

= $[(10\% \times 1 \text{ ton/m}^3) \times 10,000 \text{ m}^3] + [(30\% \times 1 \text{ ton/m}^3) \times 1,652 \text{ m}^3] = 1,495.6$ tonnes > 900 tonnes, therefore meeting minimum requirement.

Total tonnage of coarse aggregate used for super structure

= $1 \text{ ton/m}^3 \times \text{concrete volume (m}^3)$

= $1 \text{ ton/m}^3 \times 28,095.05 \text{ m}^3 = 28,095.05$ tonnes

% of total RCA used for replacing superstructure concrete coarse aggregate content

= $1,495.6 \text{ tonnes} / 28,095.05 \text{ tonnes} \times 100\% = 5.3\%$

Therefore, points scored = 0.5 points

WCS

Minimum usage requirement for WCS = $0.015 \times \text{GFA}/2 = 0.015 \times 60,000/2 = 450$ tons

Total concrete volume of all slabs = $400 \text{ m}^3 + 320 \text{ m}^3 \times 30 = 10,000 \text{ m}^3$

Total tonnage of fine aggregate used for super structure

= $0.7 \text{ ton/m}^3 \times \text{concrete volume (m}^3)$, $0.7 \text{ ton/m}^3 \times 28,095.05 \text{ m}^3 = 19,666.5$ tonnes

[Approximate fine aggregate content in concrete = 0.7 ton/m^3]

Total tonnage of WCS used for super structure

= $[(5\% \times 0.7 \text{ ton/m}^3) \times 10,000 \text{ m}^3] = 350$ tonnes < 450 tonnes, therefore not meeting minimum requirement.

Therefore, points scored = 0 points

Therefore, points scored for this sub-section = $0.5 + 0.5 = 1$ point

Therefore, point scored under for 3.02a including = $2 + 1 = 3.0$ points

Use of Advanced Green Materials (Advanced Green Effort)

Documentation Requirements

(A) Design Stage

- As per 3.2aiii *Low Carbon Concrete* for SGBC-certified 4-Tick concrete
- Extract of tender specification or proposed use of SGBC-certified reinforcement bars for structural reinforced concrete elements for more than 80% of the applicable superstructural elements by volume
- SGBC certification of the reinforcement bars used for the project

(B) Verification Stage 1

- As per 3.2aiii *Low Carbon Concrete* for SGBC-certified 4-Tick concrete
- As-built drawings highlighting if there is deviation of the building design or usage scope of SGBC-certified reinforcement bars in the project.
- Purchase orders (POs) or Delivery orders (DOs) and details of the SGBC-certified reinforcement bars used in the project
- SGBC certification of the reinforcement bars used for the project

3.2b Embodied Carbon

Documentation Requirements

(A) Design Stage

- Embodied carbon footprint computation saved and exported in PDF format via BCA Carbon Calculator and submitted with the relevant supporting documentation and calculations. Preliminary/ proposed concrete mix designs are acceptable at the design stage, but need to be updated if there are any amendments made to the designs during the verification stage
- For declaration of emission factors via BCA's online embodied carbon calculator, project team must provide the sources of the emission factors with the relevant detailed calculations
- Detailed report of the carbon footprint of the development including (but not limited to) the quantum and types of materials used within the development, the emission factors with supporting documentation. Examples of other contributing elements that can be considered include emissions from activities during the construction phase and transportation.

(B) Verification Stage 1

- Updated concrete mix designs highlighting the amendments/ changes in the mixes (with supporting documents) if applicable
- Updated carbon footprint computation if there is deviation from the submission at the design stage

Worked Example

Examples of additional materials that can be declared: Aluminium, paint, timber flooring, ceramic tiles etc.

3.2c Sustainable Products

(i) Functional Systems

Definitions

Speculative building: A building where the specific tenants are unknown during the period of its construction.

Non-speculative buildings: A building where the specific tenants are known during the period of its construction.

Functional systems: The term is used to describe the holistic use of products within the respective functional (operational) systems. The interior architectural fit-out of buildings is made out of 6 major building components for specific functional uses, e.g. the external wall, internal wall, flooring, doors, ceiling and roof. The functional systems described in the Green Mark criteria awards Green Mark points when products are used holistically in the respective functional use. The products included in the functional system are dependent on the choice of products and the installation methodology to provide the functional system for what the space is designed to be used for. Products are thus classified into need-based groups/ systems. As such, the criteria recognises the use of less resources - where a functional system could meet the operational requirement by using less products, this is still considered as meeting the functional system objective. For example, if there is no need to plaster or skim coat to the slab soffit nor need for ceiling boards to cover the overhead, this can be considered to have met the functional system requirement for ceiling for that sectional area of the application.

Guidance Notes

There are two options for scoring as shown below, excerpted from the Criteria document. The project should decide on either one which is most appropriate for its context. The first table *Non-Speculative Buildings/ Speculative Buildings with Tenanted Areas Included* includes tenanted areas in the points computation. It applies for non-speculative buildings where the fit-out products, including tenant spaces, are known and to be included for the assessment. Speculative buildings where the building owners have the power to influence and control the tenants fit-out, such as through green leasing measures, could also apply the table.

The second table *Speculative Buildings with Tenanted Areas Excluded* applies for speculative buildings where the decision on the type of products are to be used in tenant spaces is not known and wants to exclude the area from assessment.

Non-Speculative Buildings/ Speculative Buildings with Tenanted Areas Included

Functional System Category	External Wall*	Internal Wall	Flooring	Doors	Ceiling	Roofing*
Base Group (Coverage: $\geq 60\%$)	1 pt	1 pt	1 pt	1 pt	0.5 pt	0.5 pt
Finishes Group (Coverage: $\geq 60\%$)	2 pt	2 pt	2 pt	0.5 pt	0.5 pt	0.5 pt

* $\geq 80\%$ coverage for external wall & roofing

Speculative Buildings with Tenanted Areas Excluded

Functional System Category	External Wall	Internal Wall	Flooring	Doors	Ceiling	Roofing
Base Group (Coverage: $\geq 80\%$)	1 pt	0.5 pt	0.5 pt	0.5 pt	0.25 pt	0.5 pt
Finishes Group (Coverage: $\geq 80\%$)	2 pt	1 pt	1 pt	0.25 pt	0.25 pt	0.5 pt

For the first table, the coverage of certified products in the functional systems shall be at least 60% of the area where the functional system is applied. For the second table, the percentage shall be at least 80%. However, please note that the roof and external wall for speculative and non-speculative buildings are independent of the tenants fit-out, and thus the points accorded for the greening of these functional systems are the same. The qualifying area coverage at 80% is applicable for both scenarios for these 2 specific functional systems.

Products are grouped within respective Groups - Base or Finishes Group - to form a holistic system. The Base Group will be a pre-requisite for its respective Finishes Group; i.e. the Base Group for the respective system shall achieve the score before the Finishes Group qualifies for scoring. The area coverage is determined as a system stacked; i.e. the spread of area where the base group qualifies, the same area will be evaluated whether the finishes installed qualifies.

All products under each Group (where used during building operation) shall all be green certified to score for the respective grouping. Where a product is not required to be used (by design requirement for operation) in the specific grouping, the non-use may be deemed to have met the requirement. The tables below list broad examples of the applicable products in respective group and functional systems. The list is non-exhaustive:

External Wall Functional System

Group	Typical Products	Points
Base Group	Curtain wall, integrated wall system, wall panels, blocks, metal cladding, waterproofing, sealant, adhesives, jointing, grouting, pointing, (fixing brackets may be excluded)	1
Finishes Group	<ul style="list-style-type: none"> All external face finishes including skim coats, external paints (including primers), external coatings, corner beads, corner protectors All internal face finishes including skim coat, internal paint, corner beads, corner protectors, fabrics, wall papers, wall tiles etc. 	2
<p><i>Notes:</i> Where a product is not required for use within the grouping, it may be considered to have met the requirement. Excludes structural walls, external architectural aesthetic features and openings. Areas are taken on both sides of the walls.</p>		

Internal Wall Functional System

Group	Typical Products	Points
Base Group	Lightweight wall panels, drywalls, blocks, waterproofing, jointing, wall grouting, boarding insulation (fixing frame may be excluded)	1
Finishes Group	All finishes including plastering, skim coat, corner beads, corner protectors, fabrics, wall papers, wall tiles, tiles grouting vinyl, laminates, veneers, adhesives, paint etc.	2
<p><i>Notes:</i> Where a product is not required for use within the grouping, it may be considered to have met the requirement. Areas are taken on both sides of the walls.</p>		

Flooring Functional System

Group	Typical Products	Points
Base Group	Levelling base, floor screed, waterproofing	1
Finishes Group	<ul style="list-style-type: none"> Raised floor systems (Insulation, underlay, carpets/ carpet tiles) Floor finishes including underlays, coatings, grouting, pointing, skirting, adhesives, carpets, vinyl's, tiles, laminate flooring, timber flooring, marble flooring etc. 	2
<p><i>Notes:</i> Where a product is not required for use within the grouping, it may be considered to have met the requirement. Excludes structural floor slab</p>		

Door Functional System

Group	Typical Products	Points
Base Group	Glass door, door leaf, door finishes including laminates, paint and veneers/ vinyl sheets, varnish, coatings	1
Finishes Group	Door accessories, i.e. door frame, door frame finishes, ironmongery	0.5

Notes:
Where a product is not required for use within the grouping, it may be considered to have met the requirement.
The Finishes Group here refer to the door accessories and not the door finishes.

Ceiling Functional System

Group	Typical Products	Points
Base Group	Plastering, skim coat (<i>Note where the ceiling is an off form soffit finish, it is deemed to comply</i>)	0.5
Finishes Group	Ceiling boards (excluding framing, fixing and bracing), insulation adhesives, paint finish, coatings	0.5

*Note: Where a product is not required for use within the grouping, it may be considered to have met the requirement.
Excludes structural slabs ceiling slabs*

Roofing Functional System

Group	Typical Products	Points
Base Group	<ul style="list-style-type: none"> For RC flat roofs: Levelling base, screed, waterproofing, insulation For Framed Roof: Waterproofing, insulation (excluding structural frame) 	0.5
Finishes Group	All finishes including metal sheets, roof tiles, tile grouts, tiles, paints and coatings, adhesives, pointing, skirting	0.5

Notes:
Where a product is not required for use within the grouping, it may be considered to have met the requirement.
Excludes structural roof slabs/ framing. The Roofing Functional System only includes products above/ interspersed between the structural slab/ frame of the roof.

Documentation Requirements

(A) Design Stage

- Extracts of the tender design specification showing:
 - The building functional system(s) which the project targets to score points for, and descriptions of each
 - The requirements to use certified environmentally friendly products for components making up the functional system(s), where they are used (*Note: If within the functional system a component is not used, e.g. where off-form concrete finish is the final finish base in the design specifications as the final finish for use in operation, there is hence no need for additional tiling (or other) finishes. In this example, there is hence no need for additional tiling to be installed to qualify the finishes group. The off-form finish is deemed to have completed the finishes group.*)
- Tabulation of the functional system(s) which the project targets to score points for in the table format prescribed by BCA under the worked example

- Design drawings marking the extent of use for each compliant functional system and the calculation of the extent of use.
- Design details of the systems used within each functional system; i.e. construction method/ method statement details
- Product catalogues and certificates (if the product selection is confirmed)
- For speculative building projects which choose to include tenant future installations in their computation, to show evidence and document that building owner can assure that the requirement will be met by tenants; such as, tendency agreements etc:
 - tenanted fit-out components within the building functional system(s) which the project targets to score points for, and descriptions of each
 - The requirements to use certified environmentally friendly products for components making up the functional system(s), where they are used

(B) Verification Stage 1

- As-built drawings showing the extent of use of green products within the functional systems
- **Purchase Orders (POs) or Delivery Orders (DOs)** of products with their corresponding green product certificates
- For projects which include tenant future installations in their computation, to show evidence that the requirement will and / or is to be met. Where tenants have completed their fit-out, to show documentation that the tenant fit-out materials included in the scoring are green certified

Worked Example

Example 1: This is the ceiling of a single storey non-speculative building, Building A, inclusive of tenanted areas.

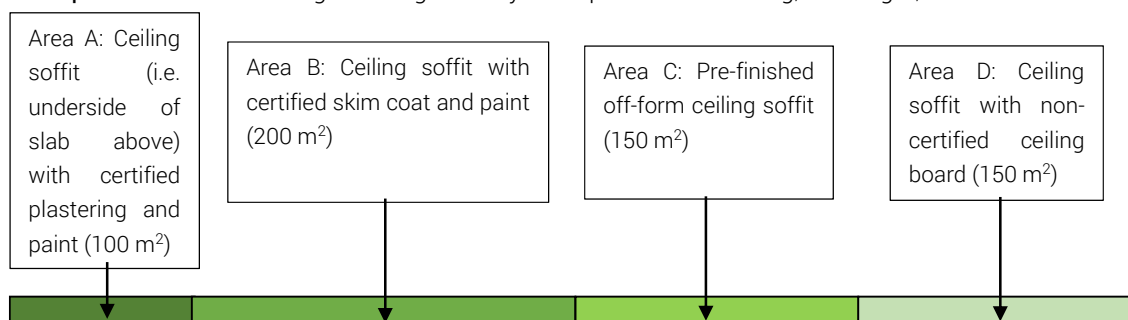

Tabulating the areas for Ceiling Functional System, bearing in mind structural items are excluded:

Area	Applicable items under Base Group	Applicable items under Finishes Group
A (100m²)	Certified plastering and certified paint	No additional product required
B (200m²)	Certified skim coat and certified paint	No additional product required
C (150m²)	No additional product required	No additional product required
D (150m²)	No additional product required	Non-certified ceiling board
Total area that considered meet requirement	All areas meet requirement (100%)	Areas A, B and C meet the requirement. Coverage = $\frac{100+200+150}{100+200+150+150} = 75.0\%$
Points	As Base Group coverage is > 60%, 0.5 point can be scored.	As Base Group coverage is >60% including tenants, project is eligible to score for Finishes Group.

	As area coverage for certified finishes under Finishes Group > 60%, points scored for Finishes Group = 0.5 point.
Total points for Ceiling Functional System = 1 point.	

Example 2: This is the internal walls of a single storey speculative building, Building B. Area D belongs to tenanted area.

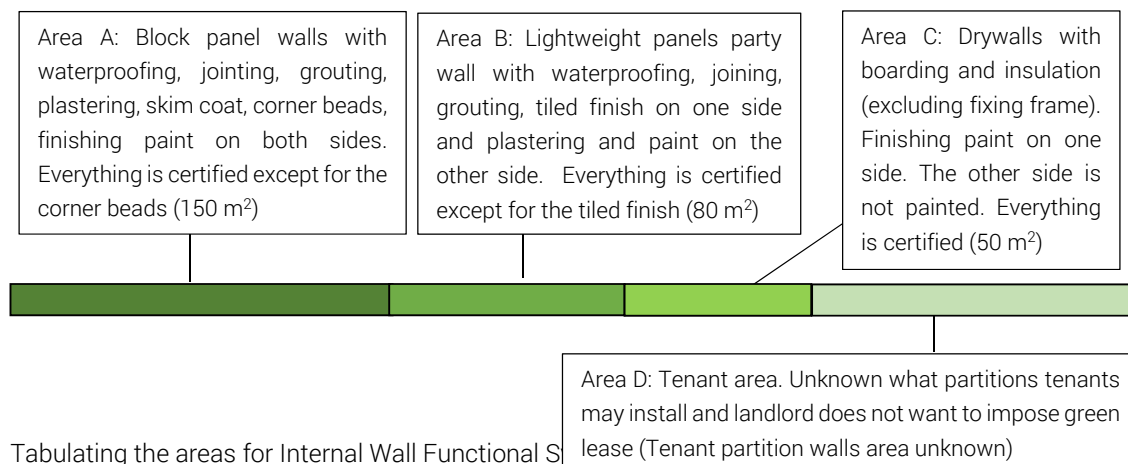

Tabulating the areas for Internal Wall Functional S

Area	Applicable items under Base Group	Applicable items under Finishes Group
A (150 m ²)	Block panel walls with waterproofing, jointing, grouting. All are certified.	Plastering, skim coat, corner beads, finishing paint on both sides. Everything is certified, except for the corner beads.
B (80 m ²)	Lightweight panels party wall with waterproofing, jointing, grouting. All are certified.	Non-certified tiled finish on one side and certified paint on the other side. All plastering used is certified.
C (50 m ²)	Drywalls with boarding and insulation (excluding fixing frame). Everything is certified.	Certified finishing paint on one side. The other side is not required to be painted hence is deemed to comply.
D (Unknown)	Unknown	Unknown
Total area that considered meet requirement	Areas A, B and C meet requirement. Coverage excluding tenanted area = 100%	One face of Area B and both faces of Area C meet requirement. Coverage excluding tenanted area= $\frac{80+(50 \times 2)}{(150 \times 2)+(80 \times 2)+(50 \times 2)} = 32\%$
Points	Project chooses to score using the table on excluding tenanted areas. As Base Group coverage is $\geq 80\%$, points can be scored =0.5 pt	As Base Group coverage is $\geq 80\%$ excluding tenants, project is eligible to score for Finishes Group. However, as area coverage for certified finishes under Finishes Group <60%, points scored for Finishes Group = 0 point
Total points for Internal Wall Functional System = 0.5 point.		

Example 3: Building C is a speculative type retail building which plans to score points for Internal Wall, Flooring and Door functional systems. Tenanted areas will be under green lease; i.e. the building owner has influence and control on the type of fit-out materials to be used by tenants. The points are computed as follows:

Description	All Certified Products?	Coverage	% of Functional System	Green Mark Points Achieved
Internal Wall Functional System				
Coverage: All internal wall of development including balconies with finishes (5,000 m²)				
Base Group				
1. Block and panel walls (Includes waterproofing, jointing, wall grouting)	Yes	100 m ²	2%	1 point (100% of area is green certified)
2. Lightweight panel party walls (Includes waterproofing, jointing, wall grouting)	Yes	800 m ²	16%	
3. Lightweight panels for wet areas (Includes waterproofing, jointing, wall grouting)	Yes	250 m ²	8%	
4. Lightweight panel walls for back of house and services, plant rooms (Includes waterproofing, jointing, grouting)	Yes	150 m ²		
5. Drywalls for all tenanted spaces (Includes boarding, insulation. Excludes fixing frame)	Yes	3,700 m ²	74%	
Finishes Group				
1. Block and panel walls: C cement plastering, corner beads, and corner protectors where applicable; excludes fixing brackets) and finished with paint on both sides	Yes	100 m ²	2%	2 points (97.5% of area is green certified)
2. On lightweight panels party walls: Combination of cement plastering & skim coat, corner beads, and corner protectors where applicable, excludes fixing brackets) and finished with paint on both sides	Yes	800 m ²	16%	
3. Lightweight panels in tenants' wet areas: Non-certified tiled finish on one side of the lightweight panels in tenants' wet areas, and with certified plastering and painted finish on another side	Yes (partial)	125 m ² out of 250 m ² (only half face of wall qualifies)	2.5%	
4. Lightweight panel walls for back of house and services, plant rooms; Cement plastering with paint finish on one side and bare finish (no finishing) on the other side	Yes	150 m ² (bare finish or no finish; 2nd level may be consider as meeting requirement)	3%	
5. Finishing paint on both sides of the drywalls for all tenanted spaces	Yes	3,700 m ²	74%	

Description	All Certified Products?	Coverage	% of Functional System	Green Mark Points Achieved
Flooring Functional System				
Coverage: All floors of development including balconies with finishes (2,500 m ²)				
Base Group				
1. Floor of circulation spaces and tenanted spaces: Floor screed	Yes	1,900 m ²	76%	1 point (100%)
2. Floor screed and waterproofing in wet areas	Yes	500 m ²	20%	
3. Floor of service area: Floor screed	Yes	100 m ²	4%	
Finishes Group				
1. Floor of circulation spaces: Certified floor tiles and grouting	Yes	700 m ²	28%	2 points (88%)
2. Floor of tenants' spaces: Combination of certified timber flooring and adhesives and final coating, non-certified marble flooring	Yes	Certified: 900 m ² out of 1200 m ²	36%	
3. Floor of wet areas: Certified floor tiles and grouting	Yes	500 m ²	20%	
4. Floor of service area: No finish (i.e. cement screed finish)	Yes	100 m ²	4%	

Description	All Certified Products?	Coverage	% of Functional System	Green Mark Points Achieved
Door Functional System				
Coverage: All doors of development (100 nos)				
Base Group				
1. Doors to service spaces: Non-certified timber hollow core and certified low VOC paint system (include basecoat and final coats)	No	9	91 nos.	1 point (91%)
2. Doors to units: Certified timber fire rated doors with certified veneer and finishing coats	Yes	85		
3. Other doors: Certified glass door with no finish required	Yes	6		
Finishes Group (Door Accessories)				
1. Doors to service spaces: Certified door frame with certified low VOC paint finish for the frame	Yes	9 (not eligible because 1 st level base is not a certified products)	81 nos.	0.5 points (81%)
a) Door to tenanted spaces: Certified door frame with certified veneer and finishing coats	Yes	75		

b) Doors to units: Certified door frame with non-certified veneer for frame	No	5		
2. Other doors: No frame required	NA	6		

(ii) Singular Sustainable Products outside of Functional Systems

Guidance Notes

Examples of hardscape, building services and M&E products (non-exhaustive)

- Water drainage products: Drains, gratings, drainpipe, culvert, rainwater collection tanks
- Landscape products: Drainage cells, green wall/ roof planting system, man-made grass, slope retainers, certified termite treatment, certified swimming pool/ pond water treatment
- Pedestrian and vehicular products: Pavers, road humps, wheel stoppers, road kerbs
- Community leisure products: Playground equipment, fitness/ playground flooring, decking, outdoor furniture
- Mechanical and Electrical products: Chillers, transformers, switchboards, pumps, fans, motors; sensors, distribution boards, electrical Energy Storage System (ESS) (typically used for storing renewable energy)
- Firefighting products
- Plumbing and sewerage products: Piping and joints, inspection chambers
- Other building products: Shading devices, light (sun) pipes, connectivity, cabling, ducting, toilet partitions, workstations

Documentation Requirements

(A) Design Stage

- Extracts from the tender specification and drawings showing the requirements to incorporate the environmentally friendly singular products that are certified by the approved local certification body for at least 80% of the respective applicable use
- Product catalogues and certificates (if the product selection is confirmed)

(B) Verification Stage 1

- As-built drawings showing the extent of use of each green certified singular product
- Delivery orders of products with their corresponding green product certificates

Worked Example

Project X has drainage cells and chillers with green certification.

Therefore, points scored for 3.2c (ii) = $0.25 \times 2 = 0.5$ point

Sustainable Products with Higher Environmental Credentials (Advanced Green Effort)

Documentation Requirements

(A) Design Stage

- Extracts from the tender specification and drawings showing the requirements to incorporate the higher ticks SGBP products for at least 80% of the respective applicable use
- Product catalogues and certificates (if the product selection is confirmed)

(B) Verification Stage 1

- As-built drawings showing the extent of use of each higher tick product (note that tenanted areas should be included in the coverage)
- Delivery orders of products with their corresponding green product certificates

Worked Example

Project X has internal partitions that are SGBP 2 ticks. As the partitions in tenants' spaces are unknown, the project is unable to quantify that the Internal Wall Functional System (including tenants) achieves the percentage coverage requirement of 60% for speculative buildings.

All its drainage cells are SGBP 3 ticks, and all chillers are SGBP 4 ticks.

Therefore, points can be scored only for drainage cells and chillers, as coverage $\geq 80\%$ of applicable use. Points cannot be scored for the higher ticks rated internal partitions as the project was unable to show that the total wall area coverage is $\geq 60\%$ of applicable use (including walls in tenants' spaces). Points scored = $0.5 + 1.0 = 1.5$ points.

3.3 Waste

3.3a Environmental Construction Management Plan

Guidance Notes

The environmental construction management plan should contain the following:

- Energy Targets: Total energy consumption target set for the construction which includes the quantity of diesel, electricity from the grid (kWh)
 - The benchmark should be normalised to the building GFA to facilitate future benchmarking for projects
 - Detailed recommendations for on-site energy management strategies
- Water Targets: Total water consumption target set for the construction in m^3
 - The benchmark should be normalised to building GFA to facilitate future benchmarking for projects
 - Detailed recommendations for on-site water management strategies
- Waste Targets: Dominant waste streams and means of collection and recycling
 - The benchmark to reduce construction waste shall be established as waste (kg)/GFA (m^2) of building
 - The waste recycling rate shall be established as percentage of waste diverted from landfill or incineration plant

- Monitoring and Reporting Method: Monitoring and measurement procedures for the usage of resources, waste and recycled streams on site, and how the targets are tracked, monitored and reported to ensure effective implementation of the environmental construction management plan

Documentation Requirements

(A) Design Stage

- Submission of the environmental construction management plan that would be implemented on site which should include definitive energy, water and waste target set for the construction

(B) Verification Stage 1

- Environmental construction management plan with written narrative of the overall environmental performance and resource usages during construction as well as measures taken to rectify any abnormality in the usage of resources where applicable
- Detailed charts showing the actual energy, water and waste monitoring and trending data against the benchmarks set at design stage as well as detailed records of the waste volume that were sent to the relevant approved recyclers are to be included

3.3b Operational Waste Management

Documentation Requirements

(A) Design Stage

- Waste management plan detailing the separation of waste expected within the building based on its use.
- Plan layout showing the location of the recycling facilities for collection and storage of the relevant recyclables
- For buildings with large volumes of organic food waste, the provision of facilities or systems for the segregation of food waste for separate collection, or the provision of an onsite food waste recycling system.
- Specifications of separate chute for recyclables, Pneumatic Waste Conveyance Systems (PWCS). The separate chute for recyclables does not include storage and sorting.

(B) Verification Stage 1

- As-built plans and photographs showing the location of actual recycling facilities for collection and storage of the relevant recyclables where applicable
- Contractual arrangement with waste collection vendors for offsite recycling where applicable.
- As-built drawings and onsite photographs of separate chute for recyclables and Pneumatic Waste Conveyance Systems (PWCS).

4. Smart and Healthy Building

P.8 Thermal Comfort

Documentation Requirements

(A) Design Stage

- Extracts of tender specifications showing the requirement to design the system to meet the requirement of thermal comfort stipulated in *SS553 : 2016*
- Design details showing how the air conditioning system shall provide consistent indoor conditions for thermal comfort

(B) Verification Stage 1

- On-site measurements verifying indoor air temperature and the relative humidity with measurement locations highlighted on a plan

P.9 Minimum Ventilation Rate

Documentation Requirements

(A) Design Stage

- Minimum outdoor air interpretation and computation by zones according to *SS 553: 2016* Table 1 or Table 5
- The maximum exhaust airflow interpretation and computation by zones
- Extracts of tender specification showing the requirement to design the system to meet the requirement of Table 1 or Table 5 in *SS 553 : 2016*
- Mechanical design drawings and schematics reflecting the minimum outdoor supply air to individual zones

(B) Verification Stage 1

- As-built drawings showing the outdoor air supply to the air distribution systems
- Onsite photographic evidence of the outdoor air duct opening to the air distribution systems

Worked Example

Project calculates the required minimum outdoor air for every zones according to *SS 553: 2016* and tabulated as follows:

AHU schedule

AHU	Area type	Area served (m ²)	SS553 table 1 (l/s/m ²)	Required OA amount (l/s)	Designed OA amount (l/s)	PAHU
AHU 1-1	Lobby	300	0.3	90	120	PAHU 1
AHU 1-2	Office	500	0.6	300	350	PAHU 2
AHU 2-1	Office	400	0.6	240	300	PAHU 1
AHU 2-2	Office	400	0.6	240	300	PAHU 2
AHU 3-1	Office	400	0.6	240	300	PAHU 1
AHU 3-2	Office	400	0.6	240	300	PAHU 2

AHU 4-1	Office	400	0.6	240	300	PAHU 1
AHU 4-2	Office	400	0.6	240	300	PAHU 2

PAHU schedule

PAHU	Required OA amount (l/s)	Designed OA amount (l/s)
PAHU 1	1020	1100
PAHU 2	1250	1300

The project meets the pre-requisite requirements by providing appropriate minimum quantum of outdoor air rates as stated in Table 1 and Table 5 of *SS 553 : 2016*.

P.10 Filtration Media for Times of Pollution

Documentation Requirements

(A) Design Stage

- Relevant design drawings and specifications depicting outdoor air filtration strategy and the design provision that MERV 14 filters can be installed during events of poor air quality. This would include fan sizing for the increased potential pressure drop, and the space for the filtration media to be placed

(B) Verification Stage 1

- As-built drawings and onsite photographs proving ability to install MERV 14 or equivalent filter during events of poor air quality

P.11 Low Volatile Organic Compound (VOC) Paints

Documentation Requirements

(A) Design Stage

- Extracts of tender specification showing the requirement to use low VOC paints that are certified by an approved local certification body
- Certification details from approved local certification body
- Technical product information and delivery records

(B) Verification Stage 1

- **Purchase Orders (POs) or Delivery Orders (DOs)** of the indoor paints used

P.12 Refrigerants

Documentation Requirements

(A) Design Stage

- Extracts from the tender specification stating the list of refrigerants that are permitted in the project based on their GWP and or ODP
- Extracts from the specification indicating the leak detection system to be installed

(B) Verification Stage 1

- List of the refrigerants used in the air conditioning system(s) and the applicable cooling systems
- Details of the installed leak detection system

P.13 Sound Level

Documentation Requirements

(A) Design Stage

- Calculations, measurements, equipment catalogues and/ or tender specifications to demonstrate that the equipment design will comply with the recommended ambient sound levels in the code

(B) Verification Stage 1

- Onsite measurement information of sound levels, complete with a method statement and plan drawings showing the relevant testing locations

P.14 Permanent Instrumentation for the Measurement and Verification of Water-Cooled Chilled Water Plants

Guidance Notes

Where the FCUs' power consumption could not be metered due to valid constraints, their nameplate power may be used to derive the air distribution efficiency.

Documentation Requirements

(A) Design Stage

The methodology for determining the total uncertainty of measurement shall be computed using the root-sum square formula as follows:

$$\text{Error}_{\text{rms}} = \sqrt{\sum(U_N)^2}$$

where

U_N = Individual uncertainty of variable N (%)

N = Mass flow rate, electrical power input or delta T

In deriving the measurement errors contributed by flow meters, an additional 1% is to be included in the computation.

The following shall be submitted:

- Detailed schematic drawings of the instruments locations and locations of test plugs
- Technical specifications and / or sample data sheets/ product information for instruments and meters
- Calculation of end to end measurement uncertainty
- Detailed drawings and schematics of the power measurement strategies for the air conditioning system (inclusive of the air distribution equipment)
- Pressure drop due to flow meter, such as reduced bore flow meter, needs to be computed in pump head calculation. For new installation, projects should design to use accurate flow meter with lesser pressure drop.
- Projects are encouraged to use metering current transformers of Class 0.5 or better to achieve better accuracy.
- Commitment to comply with the requirements

(B) Verification Stage 1

The performance verification may include on-site testing by BCA officers. A heat balance-substantiating test for water cooled chilled-water plant to be computed in accordance with *BCA Code on Periodic Energy Audit of Building Cooling System* shall be submitted with the following information:

- Energy Audit report (GM NRB: 2015)
- Purchase Orders (POs) or Delivery Orders (DOs) of the instrumentation and power meters installed
- Extracts of the instrumentation specifications and brochures
- Instrumentation calibration certificates
- As-built schematic drawings showing the location of each power meters, flow meters and temperature sensors
- BMS screenshots showing the relevant calibration inputs have been entered for the temperature measurement
- Site requirement: To determine the chilled-water plant efficiency, airside efficiency and total system efficiency using the following operation data/ installations to demonstrate compliance with the design specifications:
 - From Building Management System
 - Chilled-water plant kW/RT
 - Air distribution system kW/RT
 - Total system kW/RT
 - Chilled-water supply & return temperatures of the header to be checked for consistency against the temperatures of individual chillers and/or individual branches
 - Condenser water supply & return temperatures of the header to be checked for consistency against the temperatures of individual chillers and/or individual branches
 - Chilled-water header flow rate to be checked for consistency against the flow rate(s) of individual branches
 - Condenser water header flow rate to be checked for consistency against the flow rate(s) of individual branches
 - The accuracy of the programmed formula for the computation of the kW/RT of the various parameters
 - From the operating chiller panel(s):
 - Chilled-water supply & return temperatures to be checked for consistency against the BMS data
 - Condenser water supply & return temperatures to be checked for consistency against the BMS data

- Approach of chilled-water supply – refrigerant evaporating temperature
- Approach of condenser-water supply – refrigerant condensing temperature
- Location of the chilled-water flow meter(s) installed to comply with manufacturer's recommendations

P.15 Electrical Sub-Metering & BMS

Guidance notes

For VRF systems, the sub-metering should be able to meter the consumption of the CUs and FCUs separately so that the consumption of the VRF system can be ascertained. Where the FCUs' power consumption of air-conditioning systems could not be metered due to valid constraints, the nameplate power could be used.

Documentation Requirements

(A) Design Stage

- Sub-system equipment specifications
- Power meter and current transducer specifications
- The remote capability and link to a BMS/EMS system
- Single line diagram showing the location of the power meters
- Design of the main switchboards (MSBs) and power distribution boxes (DBs)

(B) Verification Stage 1

- Purchase Orders (POs) or Delivery Orders (DOs) of the sub-system, equipment, power meter and current transducers
- As-built electrical single line diagrams showing the location of each power meters
- As-built MSBs, DBs design
- BMS or supervisory control and data acquisition (SCADA) display of meter readings and trends
- Commissioning report of the sub-metering system

Worked Example

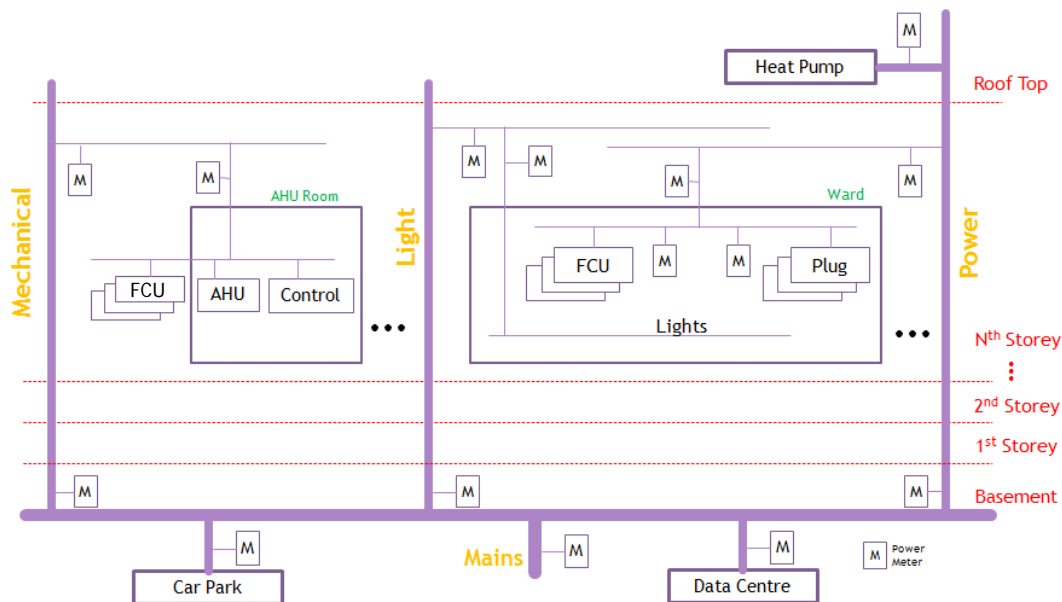

In the above metering scheme of a hospital, the energy consumption can be partitioned as follows:

- Each major energy load areas: data centre, car park, heat pump
- Each major energy use: light, plug load (power)
- Air distribution sub-system (VAV, AHU, FCU)
- Each floor and ward

There is also a private main meter to record the whole building energy consumption.

4.1 Indoor Air Quality

4.1a Occupant Comfort

(i) IAQ Surveillance Audit

Documentation Requirements

(A) Design Stage

- Extracts of the tender specifications showing the requirements to conduct an IAQ surveillance audit within one year after occupancy by an accredited laboratory, with respect to the recommended IAQ parameters and acceptable limits stated in Table 1 of SS554: 2016.

(B) Verification Stage 1

- IAQ surveillance audit report by an accredited laboratory. For functional spaces outside of the above mentioned standards/ guidelines' remit, the performance standards for the respective IAQ parameters shall be determined based on prevailing industry best practice standards
- The spreadsheet of the standardised IAQ report template is available at https://www.bca.gov.sg/GreenMark/others/IAQ_report_template.xlsx.

(ii) Post Occupancy Evaluation

Guidance Notes

The spreadsheets of the standardised POE survey questionnaire and results are available at https://www.bca.gov.sg/GreenMark/others/POE_survey_template.xlsx and https://www.bca.gov.sg/GreenMark/others/POE_results_template.xlsx

Documentation Requirements

(A) Design Stage

- Extracts of the tender specifications showing the requirements to conduct a POE within one year after occupancy and to undertake corrective actions if required. Commitment to sample at least 10% of building occupants or at least 100 occupants should be made

(B) Verification Stage 1

- Demonstration that the response rate of the POE meets the sample size
- Evaluation of the POE results and the list of the corrective actions based on the respondents' comments

(iii) Indoor Air Quality Display

Documentation Requirements

(A) Design Stage

- Extracts of the tender specifications showing the requirements to display temperature, and relative humidity at each floor and each tenanted area
- Plan layouts showing the locations of the fixed display panels for each floor and each tenanted area

(B) Verification Stage 1

- Pictures showing locations of temperature and relative humidity sensors for display
- Technical specifications the sensors
- Plan layouts showing the actual display locations and the types of sensors used

(iii) Indoor Air Quality Trending (Advanced Green Effort)

Documentation Requirements

(A) Design Stage

- Extracts of the tender specifications showing the requirements to monitor and trend-log temperature and relative humidity through a centralised system
- Plan layouts showing the locations of the sensors that are monitored and trend-logged

(B) Verification Stage 1

- Pictures showing locations of the sensors for monitoring

- Technical specifications of the sensors
- Plan layouts showing the actual display locations and the types of sensors used for monitoring
- Two-week trend-logging data from the centralised monitoring system

4.1b Outdoor Air

(i) Ventilation Rates

Documentation Requirements

(A) Design Stage

- Measurement and monitoring of outdoor airflow volume
 - Provision of detailed schematics, specifications and method statement for the provision of direct outdoor airflow measurement devices with capabilities to measure the outdoor air intake volume with an accuracy of $\pm 10\%$ of the minimum outdoor airflow
 - Demonstrate location of sensors in accordance with the manufacturer's guidelines and linkage to BMS for monitoring the outdoor air volume (A standalone data logging system can be used if no BMS is available)
 - Method statement for programming alerts, when the outdoor air volume drops below the minimum set points and varies by more than 15% above the airflow set point
 - Plan layout indicating the provision of access panel for regular maintenance of airflow sensors
- Use of demand control ventilation strategies
 - Plan layouts and schematics showing the locations and the types of control devices utilised.
 - Method statement on how the devices regulate the outdoor air volume to maintain indoor air quality.
 - When CO₂ sensors are used, demonstrate alerts have been programmed into the BMS where the CO₂ levels exceed the set point with reference to recommendations by *SS554 : 2016*

(B) Verification Stage 1

- Delivery orders, technical specifications, as-built drawings and onsite photographs of the airflow measurement devices
- BMS or standalone system logged data (minimum of a 2 week period) of the outdoor air volume and airflow

(ii) Enhanced Filtration Media

Documentation Requirements

(A) Design Stage

- Extracts of tender specification for the provision MERV 14 (ASHRAE 52.2) or F8 (EN779/EN1822) class or equivalent filters for air distribution system
- Technical specifications and air filtration classification testing report for the filters to be used for each air distribution system

(B) Verification Stage 1

- Pictures showing filter locations and installations
- Technical specifications and filtration classification testing report for the actual filters used on site

(iii) Dedicated Outdoor Air System

Documentation Requirements

(A) Design Stage

- Design intent and details of the air-conditioning and air distribution system
- Schematics of the air distribution system that are connected to the dedicated outdoor air system (Precool AHU/FCU system)

(B) Verification Stage 1

- Pictures showing locations and actual installations of the dedicated outdoor air system (precool AHU/FCU system)
- As-built drawings of the air distribution systems that are connected to the dedicated outdoor air system (precool AHU/FCU system)

4.1c Indoor Contaminants

(i) Local Exhaust and Air Purging

Documentation Requirements

(A) Design Stage

- Local exhaust:
 - Extracts of the tender specifications showing the requirements to provide local exhaust riser for local isolation and exhaust systems to remove the pollutants at source, i.e. from printing or photocopying equipment, to prevent the contamination of the functional areas. The ductwork shall be such that the exhausted air must not be recycled to other spaces. For speculative projects, the exhaust system fans must be installed as a part of the base building
 - Plans, schematics and mechanical drawings showing the location of the exhaust risers and the exhaust fans
 - A written description on the attributes of the isolation strategies and exhaust system and how tenants shall connect to the exhaust risers for indoor pollutant removal
- Air purging: Written descriptions and schematics on the air purging strategy including any requirements for dedicated fresh air intakes and indoor pollutant exhausts

(B) Verification Stage 1

- Local exhaust:
 - Pictures showing locations of exhaust systems installed
 - As-built drawings showing the installed locations of the exhaust risers, exhaust outlets and the tenants' connection points and isolation strategies
- Air purging: Air purging method statement, BMS schedules and screen shots of air purging programme for the project

(ii) Ultraviolet Germicidal Irradiation (UVGI) System

Documentation Requirements

(A) Design Stage

- Extracts of the tender specifications and schematics showing the provision of UVGI system in AHUs and FCU
- Highlight the location of the system is adjacent to and after the cooling coils
- Technical specifications of the UVGI system (UV wavelength to be 254 nm and safety interlock must be provided)
- Manufacturer's guideline on the intensity, location, reflector design and number of lights according to the AHU design

(B) Verification Stage 1

- Pictures showing locations of actual installed UVGI system
- Schedule of AHUs and FCUs indicating provision of UVGI system
- Product specifications of the UVGI system (UV wavelength to be 254 nm and safety interlock must be provided)

(iii) More Stringent Volatile Organic Compounds (VOC) Limits for Interior Fittings and Finishes

Documentation Requirements

(A) Design Stage

- Extracts of the tender design specification showing:
 - The building functional system(s) which the project targets to score points for, and descriptions of each element
 - On interior fittings such as system furniture, cabinetry etc
 - On wall or floor finishes as part of the functional system
 - The requirement stating lower or no VOC contaminant, i.e. use of SGBC 2 ticks certified products for all components containing VOC that are used in the functional system(s) for the project.

Note: For projects which include tenant future installations in their computation, to show draft tenancy agreement specifying the above requirements
- Tabulation of the functional system(s) which the project targets to score points for
- Design drawings marking the extent of use for each compliant functional system and the calculation of the extent of use
- Design details of the systems used within each functional system; i.e. construction method/ method statement details
- Product catalogues and certificates (if the product selection is confirmed)

(B) Verification Stage 1

- As-built drawings and calculation of extent of application
- Product certificates, data sheets and delivery out of interior finishes and paints

- Where furniture has been scored, details of the furniture systems within the tenanted spaces and their certification along with delivery orders. This information is subject to gathering the required evidence from the tenanted areas
- Submission of evidence showing compliance, including the calculation of the coverage meeting the requirement, shall to be submitted during the verification stage or upon request

(iv) Use of Persistent Bio-cumulative and Toxic (PBT) free lighting

Documentation Requirements

(A) Design Stage

- Specification of the luminaries used within the project and their requirement to be PBT free
- PBT-reduced luminaries can be considered if the details of the mercury content and/or other PBT elements of the luminaries can be established. Such fittings should have mercury content of $\geq 50\%$ lower than permissible limit, as per Environmental Protection and Management Act (Chapter 94A).
- Calculations of the extent of application to demonstrate $\geq 90\%$ of the luminaries used within the project area PBT-reduced or free luminaries

(B) Verification Stage 1

- Delivery orders and data sheets of the luminaries that demonstrate that they are PBT-reduced or free luminaries.

Zero ODP Refrigerants with Low Global Warming Potential (Advanced Green Effort)

Documentation Requirements

(A) Design Stage

- Extract from the tender specification showing the requirement for all zero ODP refrigerants to have low GWP as stated in the criteria

(B) Verification Stage 1

- List of the refrigerants used in the air conditioning system(s) and the applicable cooling systems

4.2 Spatial Quality

4.2a Lighting

(i) Effective Daylighting for Common Areas & (ii) Effective Daylighting for Occupied Areas

Documentation Requirements

(A) Design Stage

- With reference to Annex B: Effective Daylighting Simulation and Pre-Simulated Daylight Availability Tables Methodology and Requirements

- Tabulation of all applicable daylight area and computation of percentage of daylight areas over total areas
- Drawings to show that openings fenestrations provide daylighting to the space.
- Computation of the distance of penetration from the façade and the height of the opening / fenestration.

(B) Verification Stage 1

- With reference to *Annex B: Effective Daylighting Simulation and Pre-Simulated Daylight Availability Tables Methodology and Requirements*
- As-built drawings of the façade and layouts of the functional spaces
- Perform spot measurements of the effective daylighting through lux measurements and photographs of the applicable functional spaces

(ii) Quality of Artificial Lighting

Definitions

LM80: The Illuminating Engineering Society of North America (IESNA) approved standard for measuring lumen maintenance of LED light sources. LM-80-08 applies to the LED package, array, or module alone, not a complete system; it is testing a component level. The standard does not provide guidance for extrapolation of testing results.

Documentation Requirements

(A) Design Stage

- Light-output:
 - LED lighting: Detailed specifications and the schedule of luminaires shall be provided to demonstrate the minimum R_a lifespan rating projected by IES TM-21 method, based on LM80 test report
 - Other types of lighting which can meet the stipulated lifespan rating requirement (e.g. induction lamps): As projected by relevant applicable internationally accepted test methods
- Colour (temperature) colour uniformity in occupied spaces: Demonstrate the colour temperature and uniformity of luminaires used in all functional space. Submission of the listing of Standard Deviation of Colour Matching (SCDM) of ≤ 3 steps based on MacAdam Ellipse for LED luminaires used
- Lighting designed with minimal flicker and stroboscopic effects: Submission of specifications of high frequency ballasts with frequency > 20 kHz and LED drivers with $\leq 30\%$ flicker to demonstrate that visible flicker has been addressed.
- Meeting the minimum colour rendering index: Detailed specifications and the schedule of luminaires to demonstrate the minimum colouring rending index is in accordance with Clause 5 of *SS 531 – 1 : 2016 (2013) – Code of Practice for Lighting of Workplaces* in all areas.
- Certified LED luminaires: Schedule of LED luminaires used and relevant SGBC certification.

(B) Verification Stage 1

- Lighting delivery orders, data sheets and relevant test reports

Worked Example

The proposed development provides the following lighting quality for its occupants at various spaces:

Type of interior, task or activity	Design R _a	Reference R _a (as specified in SS531: 2006)
Office Space Type 1	80	80
Atrium	60	60
Corridor type 1	40	40
Toilet	80	80
Mechanical & Electrical Rooms	60	60
Carpark	40	40

The proposed lighting design meets the reference values as stated in SS 531: 2006 (2013) and the LED lightings installed are based on lifespan rating of L₇₀ for ≥50,000 life hours with Standard Deviation of Colour Matching (SDCM) of ≤ 3 steps based on MacAdam Ellipse, hence the project can score a maximum of 1 point under this credit.

4.2b Acoustics

(i) Sound Transmission Reduction

Definitions

Sound transmission class (STC): A rating of how well a partition attenuates airborne sound. The higher the STC is, the higher the sound reduction.

Documentation Requirements

(A) Design Stage

- STC details incorporated into the tender specifications

(B) Verification Stage 1

- Product specifications and as-built details to demonstrate compliance to design stage commitment

(ii) Acoustic Report

Definitions

Reverberation time: The length of time required for sound to diminish 60 decibels from its initial level.

Guidance Notes

Acoustic Design Report format:

- Executive Summary – summary of the key design recommendations for the project
- Acoustic Considerations:
 - Impact of the project on the immediate noise environment, especially noise sensitive accommodation, including both the construction and operational stages of the building.
 - External noise sources and propagation affecting the development
 - Internal noise sources, acoustical design and criteria used within the building
 - Internal layout planning, finishes selection and acoustical performance of the building

- Site massing, landscaping and facades design to mitigate the adverse impacts of external noise
- Façade Noise Ingress Control Criteria:
 - Noise survey methodology and standards
 - Results
 - Recommendations for façade treatment & spatial arrangement of interior spaces
- Internal Acoustic Design Criteria:
 - Sound transmission reduction targets in compliance with 4.2b (i) *Sound Transmission Reduction*. STC shall be calculated using recognised design guidelines, field or laboratory test results by certified/accredited agency or design calculations.
 - Reverberation time targets
 - This should be demonstrated via detailed design calculations or acoustic modeling.
 - Sound reinforcement systems and/or public address system (where applicable)
- Internal Acoustic Design Proposals:
 - Proposals for sound absorptive finishes and supporting calculations for typical areas
 - Proposals for sound insulation with supporting calculations or field or laboratory test results by certified/accredited agency for typical areas

Acoustic Verification Report Format:

- Environmental Noise & Survey (as-built)
 - Methodology and testing standards
 - External impact of development on the surroundings
- Façade Noise Ingress Control (as-built)
 - Façade ingress noise measurement for internal areas.
- Internal Acoustics (as-built)
 - Sound insulation measurements
 - Reverberation times measurements
 - Commissioning and handover of noise masking or sound reinforcement systems (where applicable)

Reverberation Requirements (adapted from AS/ NZS 2107):

Functional Space		Recommended Reverberation Time (<i>T60 seconds averaged between 500, 1,000 and 2,000Hz</i>)
Office	Open Plan Office	≤ 1
	Conference / Meeting Rooms	≤ 0.8 (0.4 for rooms with tele or video conference)
Institutional (Schools, Civic buildings)	Classrooms	0.6 - 1.0
	Seminar / tutorial rooms	0.6 - 0.8
	Libraries	< 1.0
	Reading rooms	0.6 - 0.8
	Music Rooms	0.5 - 0.7
	Music Studios	0.7 - 0.8
	Multi-Purpose Halls	< 1.5
Gymnasiums	< 1.5	
Hotel	Meeting Room	< 0.8

	Large Banquet Room/Hall	< 1.2
Atria/Commercial Lobby	Retail, office, institutional, or hotel atria or main lobby spaces.	To reduce as far as practicable for noise control

Calculation of reverberation time

The reverberation time can be calculated by hand where:

$$A = (\alpha_1 S_1 + \alpha_2 S_2 + \alpha_3 S_3 + \dots + \alpha_n S_n)$$

$$RT = 0.163 \times V/A$$

A - Total equivalent sound absorption area of a room (in Sabin or m²)

$\alpha_{1,i}$ - the sound absorption coefficient for different materials 1→i as specified/used in a space/room.

$S_{1,i}$ - the total surface area of different materials, 1→i corresponding to the respective absorption coefficient (m²).

RT – Reverberation Time in seconds.

V – Room Volume (m³)

Documentation Requirements

(A) Design Stage

- Acoustic design and verification report for the project based on the format under Guidance Notes. The report should be prepared by a qualified acoustician.

(B) Verification Stage 1

- Acoustic verification report of onsite testing and measurements to demonstrate that the acoustic objectives have been met, with recommendations for continued operational performance. Where defects due to workmanship are found, these should be corrected
- For sound insulation measurements, a representative sample of partitions shall be tested, i.e. 10% of the total (lower quantity if there is extensive repetition). For façade noise ingress measurements and reverberation time measurements, a selection of rooms shall be used for testing, i.e. 5% of the total (lower quantity if there is extensive repetition). Testing shall be conducted in accordance with *ISO 3382 - 3:2012 Acoustics – Measurement of Room Acoustic Parameters*

Worked Example

Example calculation [meeting room of 3.0m width, 4.0m length, 2.5m height. With 4 timber doors (1.0m x 2.4m)]

Volume of room = 30m³

Step 1: Calculate the surface area related to each absorptive material (e.g. floor, wall, door, ceiling)						
Surface	Surface Finish		Area (m ²)			
Floor	Carpet on concrete base		12			
Doors	Timber		9.6			
Walls (excluding door area)	Concrete block, painted		25.4			
Ceiling			12			
Step 2: Obtain values of absorption coefficients for the carpet, painted concrete block walls and the timber doors, and ceiling						
Surface	Area (m ²)	250 Hz	500 Hz	1,000 Hz	2,000 Hz	4,000 Hz
Floor	12	0.03	0.06	0.15	0.30	0.40
Doors	9.6	0.10	0.08	0.08	0.08	0.08

Walls	25.4	0.05	0.06	0.07	0.09	0.08
Ceiling	12	0.28	0.25	0.14	0.13	0.13
<i>Step 3: Calculate the absorption area (m²) related to each absorption surface (ie for floor, walls, doors, ceiling) in octave frequency bands.</i>						
Absorption area (m²) [Absorption area = Surface area x Absorption coefficient]						
Surface		250 Hz	500 Hz	1,000 Hz	2,000 Hz	4,000 Hz
Floor		0.36 [0.03x12]	0.72	1.80	3.60	4.80
Doors		0.96	0.77	0.77	0.77	0.77
Walls		1.27	1.52	1.78	2.29	2.03
Ceiling		3.36	3.00	1.68	1.56	1.56
<i>Step 4: Calculate the sum of the absorption area (m²) obtained in Step 3.</i>						
		250 Hz	500 Hz	1,000 Hz	2,000 Hz	4,000 Hz
Total absorption area (m ²)		5.95 (0.36+0.96+1.27+3.36)	6.01	6.03	8.22	9.16
<i>Step 5: T60 seconds averaged between 500,1000 and 2000Hz</i>						
		250 Hz	500 Hz	1,000 Hz	2,000 Hz	4,000 Hz
Reverberation Time	RT = 0.163*V/A	0.822 (0.163*30/5.95)	0.814	0.811	0.595	0.534
			0.74 [(0.814+0.811+0.595)/3] - Requirement for meeting room ≤ 0.8			

4.2c Wellbeing

(i) Biophilic Design

Documentation Requirements

(A) Design Stage

Where applicable:

- Landscape plans of the relevant accessible sky gardens, sky terraces, internal courtyards and rooftop gardens that indicate the outdoor furniture, the outdoor refreshment area
- Plan layouts and perspectives of the interior planting design at the applicable areas with calculations that demonstrate the plant coverage as a percentage of the relevant floor areas
- Short description/ plans/ sketches to demonstrate how building design has adopted biomimicry/ natural shapes and forms
- Short description/ plans/ sketches to demonstrate how building design add a sense of ecological attachment
- Layout identifying common area where images of natures has been incorporated

(B) Verification Stage 1

- As-built drawings and photographs highlighting the provision of the committed features

Worked Example

The façade of a building has been designed to look like part of a natural landscape. Potted plants and planter boxes have been placed at the lift lobbies, corridors and atrium. There are also multiple large landscape paintings hung in the atrium. The area of the common areas is 400m² while the area of the atrium is 40m².

Item	Points
Façade of a building has been designed to look like part of a natural landscape	0.25 pt (Natural form)
Potted plants and planter boxes at common areas	Potted plant area = $\pi \times r^2$ where r is the radius of the plant Planter boxes area = Length x breadth of the planter box Assume total fixed planting area totals up to 20m ² Percentage of common area with fixed indoor planting = $20 / 400 \times 100\% = 5\%$
Multiple large landscape paintings hung in the atrium	Percentage of common area with images of nature = $40 / 400 \times 100\% = 10\%$

Thus, the project can score 0.5 pt (Indoor planting) + 0.25 pt (Natural form) + 0.25 pt (Images of Nature) = 1 point for 4.2 c (i) *Biophilic Design*.

(ii) Universal Design (UD) Mark

Documentation Requirements

(A) Design Stage

- UD Mark application form, accompanied with tender documents and written commitment from the developer / building owner on the targeted level of UD Mark award

(B) Verification Stage 1

- BCA UD Mark Letter of Award

4.3 Smart Building Operations

4.3a Energy Monitoring

(i) Energy Portal and Dashboard

Documentation Requirements

(A) Design Stage

- Specifications of the energy portal, dashboard or other equivalent forms and relevant parameters such as areas, occupancy areas or use type that are to be included for monitoring and setting of energy consumption targets.
- The data acquisition system, typically a building or energy management system (BMS or EMS), must be able to store the measured data for at least 36 months, and to create reports showing hourly, daily, monthly, and annual energy consumption associated with each meter with option to export data.
- Plans and schematics to illustrate:
 - Location and means of access of the portal
 - Electrical single line diagram of the sub-metering scheme and links to a BMS or EMS

(B) Verification Stage 1

- Photographic evidences of the installed energy portal or dashboard or equivalent form displaying metered energy data by area or use and other relevant parameters as well as trending and energy benchmark.

(ii) BAS and Controllers with Open Protocol

Documentation Requirements

(A) Design Stage

- Extracts of the BMS or other equivalent building management, control and monitoring system that demonstrates that the building automation network. Controllers should comply with open and non-proprietary protocols, such as BACnet, Modbus and KNX, and provide interfaces to enable the easy integration of new devices with subsystems and facilitate scheduled and automated data export to widely-used file format such as CSV

(B) Verification Stage 1

- Commissioning report of the building management or building automation system

Permanent M&V for VRF Systems (Advanced Green Effort)

Documentation Requirements

(A) Design Stage

- Detailed catalogue and method explanation for resultant system efficiency within 10% uncertainty.
- Technical specifications and / or sample data sheets/ product information for instruments and meters for data logging.
- Calculation of end to end measurement uncertainty
- Detailed drawings and schematics of the power measurement strategies for the air conditioning system (inclusive estimation of power consumption of air distribution equipment)
- Details on how the owners or relevant parties are informed about the performance.
- Commitment to comply with the requirements

(B) Verification Stage 1

- The performance verification may include on-site check by BCA officers.
- Purchase Orders (POs) or Delivery Orders (DOs) of the instrumentation and power meters installed.
- Extracts of the instrumentation specifications and brochures.
- Instrumentation calibration certificates, where applicable.
- Extracts of data from logging system for verification of performance.

Permanent M&V for Hot Water Systems (Advanced Green Effort)

Documentation Requirements

(A) Design Stage

- As per P.14 Permanent Instrumentation for the Measurement and Verification of Water-Cooled Chilled Water Plants for central hot water system.

(B) Verification Stage 1

- As per P.14 Permanent Instrumentation for the Measurement and Verification of Water-Cooled Chilled Water Plants for central hot water system.

4.3b Demand Control

(i) ACMV Demand Control

Definitions

Binary sensing: Control is exercised based on whether the space is occupied (by one or more persons) or not

Occupancy-based sensing: Control is exercised based on measured occupancy, e.g. number of occupants

Guidance Notes

- 1 point is scored if $\geq 80\%$ of the applicable transient areas (by area) use occupancy-based sensing as a ACMV control strategy. 0.5 point is scored if binary sensing is used as a control strategy instead
- A further 1 point can be scored if $\geq 80\%$ of the applicable occupied areas use occupancy-based sensing as a ACMV control strategy. 0.5 point is scored if binary sensing is used as a control strategy instead
- The schematic of a typical multi-zone VAV-based HVAC system and a conceptual control algorithm that is implemented in an occupied zone is shown
- Part of the air removed from the occupied zone (return air) is mixed with the outside air and conditioned at the AHU to the desired temperature and humidity ratio. The conditioned air, which is usually cold and dry, is distributed to the VAV boxes at the zones through the ductwork. This temperature set point is reset dynamically based on whether the zone is occupied or not. The control strategy is based on either occupancy-based sensing or binary sensing

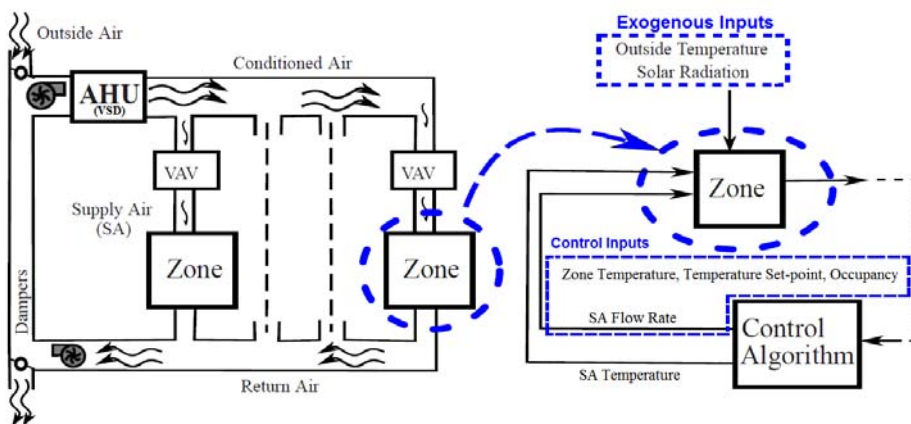

Documentation Requirements

(A) Design Stage

- Location plans of the relevant sensors demonstrating that at least 80% of the applicable areas are covered
- Specifications of the sensors and a method statement of the ACMV controls including the sensor regulation of temperature and fresh air supply

(B) Verification Stage 1

- Delivery orders of the sensors
- Specifications of the sensors installed and the associated controllers
- As-built building floor plan marked with the sensor deployment
- As-built control system screens showing the sensor inputs and the corresponding controller outputs

(ii) Lighting Demand Control

Definitions

Occupancy/ vacancy sensing: Control automatically turns light off when motion is no longer detected.

Guidance Notes

0.5 point can be scored if $\geq 80\%$ of transient areas (by area) use occupancy/ vacancy sensing as a lighting control strategy.

A further 0.5 point can be scored if $\geq 80\%$ of occupied areas use occupancy/ vacancy sensing as a lighting control strategy.

Documentation Requirements

(A) Design Stage

- Location plans of the relevant sensors that demonstrate that at least 80% of the applicable areas are covered.
- Specifications of the sensors and a method statement of the lighting controls including the sensor regulation of lighting level (brightness).

(B) Verification Stage 1

- Delivery orders of the sensors
- Specifications of the sensors installed and the associated controllers
- As-built building floor plan marked with the sensor deployment
- As-built control system screens showing the sensor inputs and the corresponding controller outputs

(iii) Carpark Guidance System

Definitions

Provide information of the number of lots for key turning points within the carpark so as to reduce the time spent by cars to find nearest available parking lots.

Guidance Notes

0.5 point can be scored for the provision of carpark guidance system.

Documentation Requirements

(A) Design Stage

- Location signage for carpark guidance system and method of detection of available parking lots.

(B) Verification Stage 1

- As-built drawings and photographs for carpark guidance system with signage.

4.3c Integration and Analytics

(i) Basic Integration and Analytics

Guidance Notes

Features needs to be displayed via BMS, BAS, website or mobile app.

Examples of “basic” integration and analytics features are (added examples with ➤ symbols):

Basic Features (Features displayed via BMS, BAS, website or mobile app)	Examples
Use <u>adaptive control algorithms</u>	<ul style="list-style-type: none"> • Adjust cooling tower approach based on wet bulb temperature ➤ Installation of condensing water temperature reset controls in cooling towers with the aid of a weather station ➤ Installation of chilled water temperature reset controls, e.g. adjust the chilled water temperature based on outside air temperature
Exception handling by identifying <u>systems that deviates from expected performance/setting</u>	<ul style="list-style-type: none"> • When efficiency of chiller plant system (in kW/RT) deviates >10% • When a space setpoint is set below a typical value • When a space operates significantly below its setpoint ➤ Comparison of outputs (controllers) set points to actual conditions to find failed devices (i.e. broken/leaking valves, broken/stuck dampers, sensors out of calibration) ➤ Unintentional manual overrides ➤ Excessive oscillation (hunting) of control points ➤ Diagnose flow measurement systems to ensure readings are in range of expectations ➤ Excessive outdoor air intake and conditioning
Detect equipment that run <u>outside intended hours or settings</u>	<ul style="list-style-type: none"> • AHUs/FCUs that run past regular office hours
Monitor equipment condition for <u>preventive maintenance</u>	<ul style="list-style-type: none"> ➤ Use embedded sensors to predict mechanical wear and failure ➤ Priorities equipment maintenance using machine condition monitoring ➤ Monitoring of chiller evaporator and condenser tube bundle pressure drops for cleaning frequency. ➤ Optimization of air filter replacement or cooling coil cleaning by monitoring changes in filter or coil pressure drop ➤ Categorise faults according to various priorities - energy, comfort, and system maintenance impact.
Basic fault detection and diagnostics (FDD) of sensors by <u>finding failed or improperly operating sensors or actuators</u>	<ul style="list-style-type: none"> • Compare set points to actual to find leaking valves or stuck dampers • Set algorithms to counter-check between sensors

Documentation Requirements

(A) Design Stage

- Extracts of the tender documents showing the provision of integration and analytics tools
- Method statements for the system integration, sensors and control strategies

(B) Verification Stage 1

- Delivery orders, user manuals and system integration and installation reports

(ii) Advanced Integration and Analytics

Guidance Notes

Features needs to be displayed via BMS, BAS, website or mobile app.

Examples of “advanced” integration and analytics features are (added examples with ➤ symbols):

Advanced Features (Features displayed via BMS, BAS, website or mobile app)	Examples
Whole system optimisation using a network of HVAC equipment	<ul style="list-style-type: none"> • Drive pumps minimally to satisfy the most demanding valve. ➤ Chiller sequencing such that each one is part-loaded enough to keep it in its most efficient operating zone ➤ Demand response using thermal mass, e.g. pre-cool the building before demand response events, then curtail load during the event to get utility incentives ➤ Use of occupancy-based map as indication of utilisation to facilitate space planning, detect vacant meeting room and manage energy-related functions such as scheduled set-back ➤ Use of video analytics to direct lifts to a crowded floor ➤ A Web or mobile application that has occupants provide direct feedback and adjust temperature and airflow to a specific zone accordingly
Integration of sub-systems to optimise resource use or improve user experience	<ul style="list-style-type: none"> • Integration of ID card access system to a hot-desk scheme
Use of Building Information Modelling (BIM) or similar applications that provide location-based visualisation of multiple sensors	<ul style="list-style-type: none"> • BIM for facilities and asset management and provide location-based visualisation in facility management ➤ Provide location-based energy or water consumption patterns ➤ Spatial condition such as temperature, humidity ➤ Use sensors’ reading to trigger facility maintenance such as cleaning or waste collection
Participate in a Demand Response programme with electricity retailer	<ul style="list-style-type: none"> • Reduce energy consumption of specific electrical items for short periods PIs refer to *Demand Response Programme by EMA.

*Link: https://www.ema.gov.sg/Demand_Response_Programme.aspx

Both lists are not exhaustive, and alternative or novel features may be proposed for scoring in this section.

Documentation Requirements

(A) Design Stage

- Extracts of the tender documents showing the provision of integration and analytics tools
- Method statements for the system integration, sensors and control strategies

(B) Verification Stage 1

- Delivery orders, user manuals and system integration and installation reports

4.3d System Handover and Documentation

Documentation Requirements

(A) Design Stage

- List of relevant mechanical, electrical and control systems that are to be tested and verified
- Commitment letter from client to undertake system verification and handover

(B) Verification Stage 1

- Written description of all the systems operation and control actions to meet the functional requirements of the system, including control strategy and logic diagrams
- Integration test results of air and hydronic systems
- Network schematic of the BMS network, showing device locations and network addresses
- Description of BMS point list including user adjustable points, hard and derived points, and their respective controller and register addresses
- Instruction manual covering details of system operation such as switching on/off, operation, isolation, fault finding, dealing with emergency conditions, precautionary measures etc., software routines for creating procedures, graphics reports etc.
- Details of software configuration along with software routines for creating procedures, graphics reports etc.
- Handover of all technical and training manuals, user guides and drawings, back-up copies of software, and consumable spares

Expanded Post Occupancy Performance Verification by a 3rd Party (Advanced Green Effort)

Documentation Requirements

(A) Design Stage

- Extracts of the tender documents showing the involvement of third party to undertake performance verification
- Method statement of the third party performance verification

(B) Verification Stage 1

- The verification report for each of the applicable building energy systems
- The recommendation report for energy optimisation for all the major energy subsystems
- Relevant operational manuals for all major energy subsystems

4.3d Energy Performance Contracting (Advanced Green Effort)

Documentation Requirements

(A) Design Stage

- Extracts of the tender documents including details on project deliverables, financial model and duration of performance contract

(B) Verification Stage 1

- Extracts of contract

5. Advanced Green Efforts

5.1 Enhanced Performance

Guidance Notes

Submission requirements for assessment shall follow the guidance for each enhanced performance indicator within the main Green Mark sections. Alternatively, where projects can demonstrate substantial performance to a specific sustainability indicator or outcome addressed within Green Mark beyond what is specified in the criteria, points can be awarded on a case by case basis following the below documentation requirements.

Documentation Requirements

(A) Design Stage

- A concise summary that articulates:
 - Environmental benefits
 - Justification of the impact of the intervention through detailed calculations and comparisons with industry norms
 - Substantiation of the calculations and comparisons with evidence and data.
- For other outcomes beyond what is specified, provide details of the enhanced performance and catalogue/specifications. Plans to measure enhanced performance should be included if applicable. BCA reserved the right to allocate suitable credits for specific outcome.

(B) Verification Stage 1

- Details of the implemented intervention including measurements and monitoring of the environmental performance including lessons learnt (if the intervention does not perform as expected).
- Purchase Orders (POs) or Delivery Orders (DOs) of relevant equipment/instrument to achieve enhance performance if applicable.
- As-built details of equipment/instrument/layout with necessary on-site check if applicable.

5.2 Demonstrating Cost Effective Design

(A) Design Stage

- Detailed quantity surveyor's report of the building

(B) Verification Stage 1

- Updated as-built report

5.3 Complementary Certifications

(A) Design Stage

- Example of complementary certificate, but not limited to, the following:
 - BCA Green Mark Award for District
 - BCA Green Mark Pearl Award
 - USGBC LEED certification.
- Extracts of the tender specification of the projects intention to apply for an approved complementary certification where possible the letter of application and details of intended rating should be included

(B) Verification Stage 1

- Details and evidence of the certification achieved

5.4 Social Benefits

(A) Design Stage

- Description of the initiatives or the project and how it contributes to social sustainability

(B) Verification Stage 1

- Report on the whether the intended social benefits were realised and lessons learnt

Annex 1: Energy Efficiency & Other Green Features [Hawker Centres]

(a) Implement an environmentally friendly procurement & purchase policy

Definitions

To set in place a policy statement that supports environmentally friendly procurement and purchases within the hawker centres, to reduce the adverse environmental impact of building owners' purchasing decisions by buying goods and products from environmentally responsible product/ service providers.

Guidance Notes

0.5 point shall be awarded for setting a sustainable and environmentally friendly procurement and purchasing policy.

Documentation Requirements

(A) Design Stage

- Establish the following policies with endorsement by Client's representative (not limited to):
 - Environmental Policy for the organisation
 - Organisation's procurement and purchase plans
 - Key appointment holders for the operation including the persons responsible for review, implementation and roll-out of these action plans

(B) Verification Stage 1

- Submission of purchase/ delivery orders of purchases with the technical product specifications indicating the environmentally friendly aspects

(b) All kitchen exhaust to be connected to centralised exhaust system with filter to remove odour or particulates

Definitions

The kitchen exhaust shall dispel smells directly through a centralised exhaust system without spreading from the kitchen stove areas to the patrons' seating areas.

Guidance Notes

2 points shall be awarded where all kitchen exhaust to be connected to centralised exhaust system with filter to remove odour or particulates.

Documentation Requirements

(A) Design Stage

- Drawings showing the schematic and layout of the proposed centralised kitchen exhaust system
- Technical specifications and product information of the various components of the exhaust system designed and installed

(B) Verification Stage 1

- As-built exhaust layout and equipment data sheets
- Purchase and/or delivery orders of the equipment used in the project
- Documentation of onsite verification of the as-built exhaust operation is achieved

(c) Design to dissipate heat load away from patrons' seating area

Definitions

To identify optimum design to dissipate heat load from kitchen stoves, heat release from customers, typical winds and kitchen hood operations etc. away from patrons' seating area.

Guidance Notes

2 points shall be awarded for compliance of CFD simulation as per *Annex A: Computational Fluid Dynamics Simulation Methodology and Requirements*

Documentation Requirements

(A) Design Stage

- CFD simulation as per *Annex A: Computational Fluid Dynamics Simulation Methodology and Requirements*

(B) Verification Stage 1

- Demonstrate compliance with the committed design specifications making reference to the as-built drawings

(d) Provision of maintenance guidelines for good Indoor Air Quality (IAQ) in hawker centres

Definitions

To develop an active IAQ maintenance guidelines for Hawker Operators to maintain good IAQ in hawker centres.

Guidance Notes

2 points shall be awarded for the provision of good IAQ maintenance guidelines for Hawker Operators. A brief outline of the guidelines is as follows (not limited to):

- Introduction – the intent of the guidelines
- Strategies to minimise odours from kitchen stoves, toilet areas, cleaning products etc.

- Preventive measures from birds and insects invading food accessible areas (e.g. seating areas, kitchens etc.)
- Provision of feedback channel for corrective actions and follow-ups
- Regular maintenance schedule and periodic review of the guidelines

Documentation Requirements

(A) Design Stage

- Guidelines prepared and endorsed by the Client's representative, complete with commitment that the project team will brief the appointed Hawker Operator on the operational requirement.

(B) Verification Stage 1

- Guidelines and evidence on the handover process to the appointed Hawker Operator.

(e) Project certified under Restroom Association Singapore (RAS) Happy Toilet Programme

Definitions

To encourage and recognise toilet owners and operators for keeping their public toilets well-maintained.

Guidance Notes

1 point shall be awarded where hawker centres' toilets are certified under Restroom Association Singapore (RAS) Happy Toilet Programme.

Documentation Requirements

(A) Design Stage

- Extract of the tender, or a signed commitment from the developer/ building owner that toilet operators shall apply for Restroom Association Singapore (RAS) Happy Toilet Programme.

(B) Verification Stage 1

- Letter of award or Happy Toilet certificate

(f) Adoption of innovative and sustainable facilities management solutions to optimise management and operation

Definitions

As part of the Smart Nation agenda, project is encouraged to adopt innovative and sustainable facilities management solutions to optimise management and operation.

Guidance Notes

2 points shall be awarded for the adoption of innovative and sustainable facilities management solutions; e.g. are Internet of Things (IoT), cloud computing, cashless payment etc.

Documentation Requirements

(A) Design Stage

- Extracts of tender documents showing the provision of facilities management solutions
- Method statements for the system integration/ operation

(B) Verification Stage 1

- Delivery orders, user manuals and system integration and installation reports

Annex 2: Energy Efficiency & Other Green Features [Healthcare]

(a) Use of energy efficient uninterruptible power supply (UPS) system

Definition

For all UPS rated ≥ 5 kVA operating in the following systems must meet the minimum efficiency:

Type	% Load	UPS Range (kVA)				
		≥ 5 to <10	10 to <20	20 - <40	40 - <200	≥ 200
Double conversion on-line mode	25% load	82.5%	86.5%	87.5%	89.0%	90.0%
	50% load	85.0%	91.0%	91.5%	92.0%	92.5%
	75% load	87.0%	92.0%	92.5%	93.0%	93.5%
	100% load	87.0%	92.0%	92.5%	93.0%	93.5%
Line interactive or ECO mode	25% load	85.5%	90%	91%	91.5%	93%
	50% load	91.5%	93%	93.5%	94%	95.5%
	75% load	92.5%	93.5%	94%	94.5%	96%
	100% load	92.5%	93.5%	94%	94.5%	96%
Stand-by mode	25% load	90%	94%	94.5%	95%	95.5%
	50% load	93%	96%	96.5%	97%	97.5%
	75% load	94%	96.5%	97%	97.5%	98%
	100% load	94%	96.5%	97%	97.5%	98%

Guidance Notes

The points awarded will be based on the aggregated kVA meeting the minimum efficiency as a proportion to the total installed kVA for UPS rated ≥ 5 kVA

Documentation Requirements

(A) Design Stage

- Drawing showing the schematic and layout of the proposed UPS system.
- Technical specifications and product information of the various components of the UPS system.

(B) Verification Stage 1

- Submission of purchase/ delivery orders of purchases with the technical product specifications of the UPS system.

(b) Use of low-loss service transformers

Definitions

All the low-loss service transformers must meet the performance metric stipulated below:

Transformer capacity	No load loss at rated voltage	Full load loss at rated voltage
Transformer capacity > 1 MVA	$< 0.25\%$ of rated load	$< 2.5\%$ of rated load
15 kVA \leq Transformer capacity ≤ 1 MVA	$< 0.35\%$ of rated load	$< 2.5\%$ of rated load

Guidance Notes

1 point shall be awarded where all transformers can meet the stipulated performance metric.

Documentation Requirements

(A) Design Stage

- Drawings showing the schematic of the proposed transformer system.
- Technical specifications and product information of the various components of transformer system.

(B) Verification Stage 1

- Submission of purchase/ delivery orders of purchases with the technical product specifications of the transformer system.

(c) Computation of service hot water demand

Definitions

To capture the actual service water heat load for healthcare facilities for domestic and service hot water demand and steam sterilization.

The SWH design flow rate is recommended to be computed based on the design flow rate per space type:

Space type	Design flow rate (litre/hr/person)
Patient room	69.6 (litre/hr) or 9(litre/min/person)
Kitchen	503.4 (litre/hr)
Café/Restaurant	1.434
Examination/treatment room/intensive care	1.434
Imaging/laboratory	2.869
Pharmacy	0.719
Procedure room/trauma/triage	2.869
Operating suite	4.780
Laundry/soiled linen	2.869
Sterilising	2.869

Guidance Notes

Computation of service hot water demand for patient's wards, kitchen and restaurant/café only (1 pt) and

Computation of additional Service hot water demand for clinical & surgery, supply and sterilizing (additional 1 pt)

Documentation Requirements

(A) Design Stage

- Computation of service hot water demand.
- Information in relation to the capability of the data acquisition system to store the measured hot water consumption data.

(B) Verification Stage 1

- Detailed record of hot water consumption.

(d) Use of local energy generation from renewable sources or waterside energy recovery for healthcare facilities with centralised hot water heating system.

Definitions

Provision of solar thermal hot water system or heat pumps or combines heat & power (CHP) system or Photovoltaic Thermal (PV/T) or other low and zero carbon technology hot water system to meet service hot water heating demand. The performance of service hot water system shall meet the efficiencies as described below:

- Solar Thermal Hot water system – Solar Factor (SF) of 0.5 or Solar Energy Factor (SEF) of 2
- Hot Water System Ratio (HWSR) of 1.60 or Heat Pump – COP of 3.5
- Combustion turbine – based CHP – Effective electrical efficiency of 0.5
- Reciprocating engine based CHP – effective electrical efficiency of 0.7

Guidance Notes

1 point shall be awarded for meeting the minimum efficiency for each category of centralised hot water system. Thereafter, additional point for every 10% improvement from minimum efficiency stated for each category (max 5pt)

Documentation Requirements

(A) Design Stage

- Drawing showing the schematic and layout of the proposed centralised service hot water system.
- Technical specifications and product information of the various components of the proposed centralised service hot water system.

(B) Verification Stage 1

- Submission of purchase/ delivery orders of purchases with the technical product specifications of the centralised service hot water system.

(e) Air side energy recovery

Definitions

Promote airside energy recovery to all healthcare ventilation system through provision of energy – recovery device with no-recirculation (i.e. 100% of the room air to be exhausted). The energy transfers efficiency of energy – recovery device shall meet the below prescribed requirement.

- Run Around coil – min 45% energy transfer efficiency
- Plate heat exchanger – min 50% energy transfer efficiency
- Thermal Wheel - 60% energy transfer efficiency
- Other types – min 50% energy transfer efficiency

Guidance Notes

1 point shall be awarded when the energy transfers efficiency of energy –recovered device meet the prescribe requirement.

Documentation Requirements

(A) Design Stage

- Drawing showing the schematic and layout of the proposed energy-recovery device.
- Technical specifications and product information of the various components of the proposed energy-recovery device.

(B) Verification Stage 1

- Submission of purchase/ delivery orders of purchases with the technical product specifications of the energy-recovery device.

(f) Provision of process water management

Definitions

To measure, manage and improve their efficiency in process water consumption using Water Efficiency Management Plan (WEMP) can be found in the PUB website:

www.pub.gov.sg/conserve/Documents/WEMP.xls

Guidance Notes

1 point shall be awarded for the adoption of WEMP.

Note: This point is not applicable for mandatory WEMP submission in healthcare premises with water consumption >5,000m³/month.

Documentation Requirements

(A) Design Stage

- Extracts of tender documents showing the provision of process water management solutions.
- Method statements for process water management plan.

(B) Verification Stage 1

- Detailed record of process water consumption.

(g) Prevent air-borne contaminate releases and NOx emission from Fuel burning process

Definitions

The emission limits of Carbon Monoxide (CO), Oxides of Nitrogen (NOx) and Particulate Matters (PM) from fuel burning process shall comply with the Code of Practice on Pollution Control (2000 edition) by NEA. In addition, Generator sets powered by engines up to 560kWm to meet hot water service demand shall meet Stage II emission:

Genset Power (kWm)	Oxides of Nitrogen (NOx) (g/kWhr)	Hydrocarbon (HC) (g/kWhr)	Carbon Monoxide (CO) (g/kWhr)
18-36	8.0	1.5	5.5
37-55	7.0	1.3	5.0
56-74	7.0	1.3	5.0
75-129	6.0	1.0	5.0
130-560	6.0	1.0	3.5

OR

Generator sets powered by engines up to 560kWm to meet hot water service demand shall meet Stage III emission:

Genset Power (kWm)	Oxides of Nitrogen (NOx) (g/kWhr)	Hydrocarbon (HC) (g/kWhr)	Carbon Monoxide (CO) (g/kWhr)
18-36	7.5		5.5
37-55	4.7		5.0
56-74	4.7		5.0
75-129	4.0		5.0
130-560	4.0		3.5

Guidance Notes

1 point shall be awarded for generator sets powered by engines up to 560kWm to meet hot water service demand meet Stage II or Stage III emission

Note: For generator sets ≥ 750 kWm, it shall be installed, operated and maintained in calibration a NOx Continuous Emission System (CEMS) with data gathering and retrieval capability

Documentation Requirements

(A) Design Stage

- Extracts of tender documents showing the emission of Carbon Monoxide (CO), Oxides of Nitrogen (NO_x), Particulate Matters (PM) and Hydrocarbon (HC) of generator sets.

(B) Verification Stage 1

- Submission of purchase/ delivery orders of purchases with the technical product specifications of the generator sets.

(h) Thermal comfort & control for each category of A/C space

Definitions

i. Air-conditioning system is designed to ensure consistent indoor thermal comfort such that

Area	Requirement
Public areas	The indoor operative temperature should be maintained between 24°C to 26°C, with relative humidity <65%, in accordance with SS553, Clause 7.2.
Patient and General Clinical Areas	The indoor operative temperature should be maintained at 24±2°C, with relative humidity <65%, or according to ASHRAE Handbook 2007 Table 3
Clinical areas with Specialized Ventilation Systems	The indoor operative temperature and relative humidity should be maintained according to HTM-03-01, Appendix 2 or equivalent international healthcare standards.
Operating Theatre and Surgery	The indoor operative temperature should be maintained between 18°C to 24°C with relative humidity ranging from 50% to 60% or according to HTM-03-01, Appendix 2.

Guidance Notes

0.25 point shall be awarded for designing air-conditioning system to ensure consistent indoor thermal comfort for each category of AC spaces.

Documentation Requirements

(A) Design Stage

- Extracts of tender documents showing design specification to ensure consistent indoor thermal comfort for public area, patient and general clinic area, clinic area with specialized ventilation systems and operating theatre surgery.
- Drawing showing the schematic and layout of the air conditioning systems.
- Technical specifications and product information of the various components of the proposed energy-recovery device for re-heating.

(B) Verification Stage 1

- Detailed record of room air temperature and RH for public area, patient and general clinic area, clinic area with specialized ventilation systems and operating theatre surgery.

Submission of purchase/ delivery orders of purchases with the technical product specifications of the temperature sensors and RH sensors.

(i) Control of indoor thermal environment by re-heating the air by provision of site – recovered energy (including condenser heat) or site solar energy

Definitions

Control of indoor thermal environment by re-heating the air is achieved by means of site-recovered energy (including condenser heat) or site solar energy.

Guidance Notes

1 point shall be awarded for controlling of indoor thermal environment by re-heating the air by means of site-recovered energy (including condenser heat) or site solar energy.

Documentation Requirements

(A) Design Stage

- Extracts of tender documents showing design specification to ensure consistent indoor thermal comfort for public area, patient and general clinic area, clinic area with specialized ventilation systems and operating theatre surgery.
- Drawing showing the schematic and layout of the air conditioning systems.
- Technical specifications and product information of the various components of the proposed energy-recovery device for re-heating.

(B) Verification Stage 1

Submission of purchase/ delivery orders of purchases with the technical product specifications of energy-recovery device for re-heating.

Annex 3: Energy Efficiency & Other Green Features [Laboratories Buildings]

(a) Use of energy efficient uninterruptible power supply (UPS) system

Definitions

As per Annex 3 [Healthcare Facilities] item a.

Guidance Notes

As per Annex 3 [Healthcare Facilities] item a.

Documentation Requirements

(A) Design Stage

- As per Annex 3 [Healthcare Facilities] item a.

(B) Verification Stage 1

- As per Annex 3 [Healthcare Facilities] item a.

(b) Design for variable ventilation and ventilation optimisation

Definitions

To reduce energy use in air-distribution systems through use of variable ventilation and ventilation optimisation.

Guidance Notes

Up to 3 points can be award for this item. 0.5 point or 1 point per feature.

Examples	Points per item
<ul style="list-style-type: none"> Segregation of areas with different ACH design for more than 30% of applicable areas Localised exhaust or provision of effective isolation zoning of heat-generating equipment for 30% of critical heat sources and instrument 	0.5 point per feature
<ul style="list-style-type: none"> Adopt risk based assessment to minimise lab ventilation rate Segregation of areas with different ACH design for more than 70% of applicable areas Localised exhaust or provision of effective isolation zoning of heat-generating equipment for 70% of critical heat sources and instrument Reuse of return or recirculated cooled air from office/support areas for air make-up to laboratories areas or design for air recirculation within laboratory while meeting safety requirement. Adopt VAV lab air flow and variable flow exhaust controls (Variable design) Multi-stack exhaust plenum with staged-exhaust fans (Shut-off design) 	1 point per feature

Documentation Requirements

(A) Design Stage

- Drawings showing the schematic and layout of the proposed variable ventilation and/or ventilation optimisation strategies.
- Computation of ventilation flowrate reduction and estimated energy saving.

(B) Verification Stage 1

- Purchase Orders and/or Delivery Orders (DOs) of relevant equipment
- Estimated energy saving from proposed ventilation strategies.

(c) Promote airside energy recovery to all laboratory ventilation system through provision of energy – recovered device with no-recirculation

Definitions

As per Annex 3 [Healthcare Facilities] item e.

Guidance Notes

As per Annex 3 [Healthcare Facilities] item e.

Documentation Requirements

(A) Design Stage

- As per Annex 3 [Healthcare Facilities] item e.

(B) Verification Stage 1

- As per Annex 3 [Healthcare Facilities] item e.

(d) Receptacle load benchmarking with existing lab to optimise cooling load design

Definitions

Establish better operation estimate of proposed laboratory's receptacle load intensity through benchmarking with existing laboratory of similar nature. Computation of energy consumption will also take into consideration of diversity, occupancy and schedule of proposed laboratory.

Guidance Notes

1 point shall be awarded for receptacle load benchmarking with existing lab to optimise cooling load design.

Documentation Requirements

(A) Design Stage

- Computation of receptacle load of existing laboratory with similar nature.
- Comparison with established international reference.
- Design to measure receptacle load of proposed laboratory and formulate methodology/guideline to facilitate that measurement in operation stage.

(B) Verification Stage 1

- Compute receptacle load intensity for operating laboratory for future reference.

(e) Include lab specific energy-efficient items under Green Lease

Definitions

Guide tenants to select and install more energy-efficient items under Green Lease to facilitate reduced energy consumption in operation. The list of items can include, but not limited to:

- Auto Sash Closure for Fume Hood
- Programmable timers for receptacles
- Use of energy efficient equipment

Guidance Notes

0.5 point shall be awarded including lab specific energy-efficient items under green lease.

Documentation Requirements

(A) Design Stage

- List of lab specific energy-efficient items under Green Lease, align with 1.1d User Engagement – Green Lease. The list will include performance or certification requirement of these items.

(B) Verification Stage 1

- Purchase Orders (POs), Delivery Orders (DOs) or Photographic evidences of lab specific energy-efficient items and information of installed equipment's performance, if applicable.

(f) Green guideline to tenants/building users include monitoring of Air Change Rate or Air Changes per hour (ACH)

Definitions

To ensure mechanisms are available to monitor air change rate operate as per required. Tenants should evaluate performance of systems and airflow needs, including non-occupancy hours, so as to reduce energy consumption within safety limits.

Guidance Notes

1 point shall be awarded for including green guideline to tenants/building users to monitor Air Change Rate or Air Changes per hour (ACH) of their laboratories.

Documentation Requirements

(A) Design Stage

- Details of guidelines stipulated to ensure tenants/building users monitor Air Change Rate or Air Changes per hour (ACH) for their laboratories.

(B) Verification Stage 1

- Air Change Rate or Air Changes per hour (ACH) chart for the laboratories.

This could include strategies to improve the performance of systems and reduce airflow needs, including those during non-occupancy hours, in future. Strategies should reduce energy consumption while meeting safety requirements.

(g) CFD study for exhaust air to prevent pollutants without sufficient dilution from entering neighbouring buildings.

Definitions

The exhaust of laboratory buildings could harm occupants of neighbouring buildings if the air is taken as fresh air without sufficient dilution. Hence, it is necessary to evaluate exhaust air flow mechanism to prevent pollutant of exhaust from entering neighbouring building without sufficient dilution.

Guidance Notes

4 points shall be awarded conducting CFD study for exhaust air to prevent pollutants from entering neighbouring buildings without sufficient dilution. CFD study shall comply *Annex A: Computational Fluid Dynamics Simulation Methodology and Requirements*.

Documentation Requirements

(A) Design Stage

- CFD study with consideration of
 - exhaust location and discharge height,
 - wind speed and direction,
 - terrain topology (including reasonable representation of surrounding buildings/structure),
 - neighbouring buildings' fresh air intake locations,
 - discharge elements, with reference to safety limit

(B) Verification Stage 1

- Onsite verification of installed exhaust system and neighbouring buildings with respect to study done during design stage.

(h) (Option 2) Setback control for Non-Occupancy Operation

Definitions

During non-occupancy operation, pollutants that are harmful to human exposure could be of a higher value as long as they comply with fire safety requirements. During such a time, the dilution of air is set to a lower extent so as to facilitate energy saving with reduced air flow requirements.

Guidance Notes

2 points shall be awarded if there is setback control for non-occupancy operation which requires:

- ACH for non-occupancy hours to be <60% of maximum operating ACH (for Biological/Chemical Laboratories)
- Reduced ventilation/lighting operation during non-occupancy hours (for Physical Laboratories)

This credit is scorable only if option 1 - double weightage for 4.03 b(i) ACMV Demand Control credit is not scored. It requires mechanism/systems in place to determine non-occupancy/occupancy. Systems will need to resume back to occupancy mode when occupancy is determined and should cater for ramp-up for pre-occupancy.

Documentation Requirements

(A) Design Stage

- Details of mechanisms to detect non-occupancy/occupancy and associated setback controls.
- Specifications/catalogue of equipment (including sensors) to facilitate setback operations.

(B) Verification Stage 1

- Profile of setback due to non-occupancy and ramp-up due to occupancy for daily operations.
- Purchase Orders (POs) or Delivery Orders (DOs) of relevant equipment (including sensors) to facilitate setback operations.
- Energy saving computation of setback control.

Annex 4: Energy Efficiency & Other Green Features [Schools]

(a) Provision, communication and dissemination of environmental policy that covers energy, waste and water management plan and green procurement

Definitions

To set in place a policy statement that facilitates better environmental performance of energy and water management and promote waste minimisation, supports environmentally friendly procurement and purchases within the school. The communications and dissemination of environmental policy to school community increases awareness on the environmental responsibility of the school community.

Guidance Notes

0.5 point shall be awarded for setting an environmental policy which covers energy, water and waste management plan and green procurement and purchasing policy; and communicate/disseminate the policy to school community.

Documentation Requirements

(A) Design Stage

- Establish the following policies with endorsement by Client's representative (not limited to):
 - Environmental Policy that covers energy, waste and water management plan for school community
 - School's green procurement and purchase plans
 - Key appointment holders for the operation including the persons responsible for review, implementation and roll-out of these action plans
- State the target audience to disseminate the environmental policy

(B) Verification Stage 1

- Submission of evidence on the communication and dissemination of environmental policy to the school community (e.g. publish the policy on school website, emails, talks etc)

(b) Raising Awareness on Environmental Sustainability through creation of Sustainability Education

Definitions

To increase environmental sustainability awareness amongst students and staff through proactive school wide efforts and sustainability education.

Guidance Notes

0.5 point shall be awarded for the following sustainability education, capped at 2 points.

- Develop framework for Environmental Sustainability Education, such as incorporating bespoke curriculum to be taught to students of different levels;
- Setting up of environmental club;
- Spread awareness on environmental sustainability amongst staff and students through posters, courses, competitions programmes or green corner;
- Implement student-led programmes or activities related to environmental sustainability.

Documentation Requirements

(A) Design Stage

- Commitment to raise environmental sustainability awareness through sustainability education.

(B) Verification Stage 1

- Framework developed for the Environmental Sustainability Education for students of different levels.
- Document to show the environmental club activities and state the number of members in the club.
- Site visit to the green corner and poster displayed in school compound, or photo evidence/relevant documents on the courses and competitions carried out.
- Photo evidence of the environmental sustainability activities being carried out and led by students.

(c) Communication of Energy and Water Efficiency Trends

Definitions

To encourage school to conduct continuous monitoring of their energy and water consumption and able to identify causes of sudden changes in energy and water consumption and implement necessary corrective actions. Through communication of the energy and water consumption trends, the school community can understand collective efforts from their action can adversely affect the school's energy and water consumption.

Guidance Notes

0.5 point shall be awarded for regular sharing of energy and water usage (minimally on monthly basis) through platforms such as newsletter, assembly and etc, with analysis on the reasons for the consumption trend.

Documentation Requirements

(A) Design Stage

- Commitment to continuous monitoring of their energy and water consumption and communicate to school community.

(B) Verification Stage 1

- Evidence on the materials used to communicate to the school community (e.g. tabulation of the monthly energy and water usage for the last 12 months and a graph showing the consumption trend).
- Evidence on how energy and water trends is communicated to the school.

(d) Higher ratio of functional areas with no air conditioning

Definitions

To encourage non-air conditioned functional areas within the school.

Guidance Notes

Up to 2 points shall be awarded based on the percentage of non-air-conditioned functional areas of total functional areas.

% Non-air-conditioned	Points
60% to \leq 70%	1
70% to \leq 80%	1.5
\geq 80%	2

Documentation Requirements

(A) Design Stage

- Relevant layout plans showing the non-air conditioned functional areas.
- Calculations to determine the percentage of the non-air conditioned functional areas.

(B) Verification Stage 1

- Actual layout plans showing the non-air conditioned functional areas.
- Calculations to determine the actual percentage of the non-air conditioned functional areas.

Worked Example

A school has the following area in the school compound.

Functional Area	Air-con area	Non air-con Area
Classrooms, workshops	-	15,000 m ²
Staff room, administration block	500 m ²	
Multipurpose Hall, Library, Threatrette	6,000 m ²	
Indoor Sport Hall	-	1,000 m ²
Canteen	800 m ²	
Outdoor football field	-	1,000 m ²
Common areas (staircase, link bridge and walkway)	-	2,000 m ²

The total functional area *excludes outdoor football field and common areas (staircase, link bridge and walkway)*, thus, the total functional area = 15,000 m² + 500 m² + 6,000 m² + 1,000 m² + 800 m² = 23,300 m²

The percentage of non-air-con functional area = (15,000+1000) / 23,300 *100% = 68%

(e) Minimising energy used to provide unnecessary or over-cooling

Definitions

To minimise energy used to provide unnecessary or over-cooling.

Guidance Notes

1 point each shall be awarded where

- room temperature of air-conditioned computer and LAN rooms is set to 24 degrees or above
- temperature of water in the water cooler is set to 15 degrees or above

Documentation Requirements

(A) Design Stage

- Specification / documents which stated the room temperature of air-conditioned computer and LAN rooms will be set to 24 degrees or above.
- Specification / documents which stated the water cooler used can be set to 15 degrees or above.

(B) Verification Stage 1

- Site visit to verify the temperature in the air-conditioned computer and LAN rooms is set to 24 degrees or above.
- Site visit to verify the water temperature from the water cooler is higher than 15 degrees.

Annex A: Computational Fluid Dynamics Simulation Methodology and Requirements

General

The CFD simulation methodology requirements encompasses 4 segments: (i) Ventilation simulation, (ii) Thermal comfort, (iii) IAQ simulation and (iv) Wind driven rain.

Green Mark Scoring Requirements

To meet the intent of *1.3c Ventilation Performance* in the Green Mark NRB: 2015 Criteria, natural ventilation simulation shall be performed, and recommendations derived shall be implemented. Minimum average wind velocities at *Moderate* level shall be met for at least 70% of the NV occupied space to score.

For building developments with $\geq 2,000\text{m}^2$ of naturally ventilated occupied spaces and targeting for Gold^{PLUS} or Platinum certification, the simulation results and the recommendations derived are to be implemented to ensure *Good* natural ventilation performance or *Very Good* natural ventilation performance respectively for at least 70% of the naturally ventilated occupied spaces.

In the event the wind velocity requirements to attain *Good* or *Very Good* natural ventilation performance are unable to be met due to certain constraints even after optimizing the building design, thermal comfort or air quality analysis shall be performed to meet the Thermal Comfort or Air Quality* requirements for naturally ventilated spaces in tropical climate. This is provided that the development has attained at least *Moderate* natural ventilation performance. All the occupied spaces shall satisfy the requirements for alternate compliance.

The requirements are summarised in the following table:

Points	Prerequisite for	Minimum Weighted Average Wind Velocity	Thermal Comfort	Air Quality
3	-	Moderate (0.2m/s)	-	-
4	Gold ^{PLUS}	Good (0.4m/s)	$-1.0 < \text{PMV} < +1.0$	Air Change Rate ≥ 4 Air Exchange Effectiveness of ≥ 1.0
	Platinum	Very Good (0.6m/s)	$-0.8 < \text{PMV} < +0.8$	Air Change Rate ≥ 10 Air Exchange Effectiveness of ≥ 1.2

*The Air Quality criteria is only applicable for sports facilities and industrial buildings with occupancy densities less than 50m^2 per person.

To score points under *Advanced Green Efforts*, wind driven rain simulation may be carried out for naturally-ventilated occupied spaces, to identify the most effective building design and layout that minimizes the impact of wind-driven rain ingress into the spaces.

Ventilation Simulation Methodology and Requirements

The natural ventilation simulation shall be carried out using Computational Fluid Dynamics (CFD) modeling to identify the most effective building design and layout for the development. The simulation results and recommendations derived are to be adopted to meet the intent of the criteria.

(i) Simulation Software

The CFD modeling shall be carried out using well validated software. The CFD solver shall have the minimum capability of solving the Navier-Stokes fluid flow equations for a three-dimensional incompressible flow at steady state. Turbulence modeling shall also be included with the minimum requirement of using the standard k-ε turbulence model, coupled with the standard wall function. *(Note: It is recommended to use the enhanced RANS eddy viscosity model (apart from the minimum realizable k-ε turbulence model) and RANS Reynolds Stress Model.)*

(ii) Conditions

All simulation models shall be carried out under isothermal conditions of 30.0°C air temperatures at steady state condition. If the impact of heat sources is significant, heat source modeling shall be included. *(Note: The aggregated heat load from heat dissipating devices shall be modelled. Boussinesq or variable density can be used.)*

(iii) Computational Domain and Surrounding Buildings

The computational domain shall include the development of interest and the far field boundary which should be located far enough from the building model to avoid artificial acceleration of the flow. As a general guideline, the direction blockage ratio (BR_L & BR_H) along lateral and vertical directions should be less than 17%.

$$BR_L = \frac{L_{Buildings}}{L_{Domain}} < 17\%$$

$$BR_H = \frac{H_{Buildings,max}}{H_{Domain}} < 17\%$$

It is also important to ensure that the blockage ratio (BR) arising from the projection of building frontal to the domain enclosure is no larger than 3%.

The surrounding buildings residing within 500 m distance from the edge of development of interest should be modelled explicitly. In the event that the building and surrounding development are located within hilly terrain with elevation more than 10 m height, the topography information should also be included in the simulation models to capture the wind redistribution arising from terrain gradient and vicinity effect. The ground surface beyond surrounding buildings site can be modelled implicitly using the Davenport-Wieringa roughness classification.

(iv) Grid size

The computational grid generated for all simulations shall resolve the salient flow features in the naturally ventilated spaces and around the development. The recommended grid sizes are as follows:

Location	Grid Size (m)
Within the functional spaces of interest	0.1 – 0.5
Building of interest	0.5 – 1.0
Surrounding building	1.0 – 5.0
From ground surface to 10m height in vertical direction	0.5 – 1.0
From 10m height to H_{max} height in vertical direction, (H_{max} is the height of the tallest building among the group of buildings modelled explicitly)	1.0 – 5.0

As a guide, the dimension of the computational elements is advised to follow the principles such as:

- Proper domain decomposition should be carried out to ensure a good quality mesh can be obtained.
- Hexahedra or prism body-fitted grid are preferred.
- A grid independent test shall be performed at the functional space through grid refinements in areas with sharp gradients.
- In terms of the computational cell quality, the skewness of the cell is advised no greater than 0.9.
- The maximum stretching ratio for near building cell size should be kept to be less than 1.4.

Boundary Condition & Turbulence Modeling

(a) Inlet Atmospheric Boundary Condition

Based on local climatic wind conditions, meteorological data on the precise wind direction and velocity of the proposed site location for the months of December, March, June and September shall be used for the CFD simulation. The prevailing wind conditions, such as the mean speed and direction for Singapore, shall be based on NEA's 18-year data at a reference height of 15.0 m as follows:

Wind Direction	Mean Velocity (U_{ref}) (m/s)
North	2.0
North-East	2.9
South	2.8
South-East	3.2

The inbound vertical wind profile shall be assumed to be given by the Logarithmic Law with reference height at 15.0 m. The wind profile shall be determined by using the following equations:

$$U(z) = \frac{u_{ABL}^*}{\kappa} \ln \left(\frac{z + z_0}{z_0} \right)$$

$$k(z) = \frac{u_{ABL}^{*2}}{\sqrt{C_\mu}}$$

$$\varepsilon(z) = \frac{u_{ABL}^{*3}}{\kappa (z + z_0)}$$

$$u_{ABL}^* = \frac{U_{ref} \kappa}{\ln \left(\frac{h + z_0}{z_0} \right)}$$

Where

u_{ABL}^* : Atmospheric boundary layer (ABL) friction velocity

κ : von Karman constant (0.42)

C_μ : A constant, generally taken equal to 0.09

z_0 : Aerodynamic roughness length

U_{ref} : The specified velocity at reference height h

The aerodynamic roughness length z_0 for wind profile should be selected from the updated Davenport-Wieringa roughness classification as follows, to match the terrain category of the development site of interest, including the tree/greenery effect.

z_0 (m)	Landscape Description
0.0002 Sea	Open sea or lake (irrespective of the wave size), tidal flat, snow-covered flat plain, featureless desert, tarmac, concrete, with a free fetch of several kilometres
0.005 Smooth	Featureless land surface without any noticeable obstacles and with negligible vegetation; e.g. beaches, pack ice without large ridges, morass, and snow-covered or fallow open country.
0.03 Open	Level country with low vegetation (e.g. grass) and isolated obstacles with separations of at least 50 obstacle heights; e.g. grazing land without windbreaks, heather, moor and tundra, runway area of airports.
0.10 Roughly open	Cultivated area with regular cover of low crops, or moderately open country with occasional obstacles (e.g. low hedges, single rows of trees, isolated farms) at relative horizontal distances of at least 20 obstacle heights.
0.25 Rough	Recently-developed "young" landscape with high crops or crops of varying height, and scattered obstacles (e.g. dense shelterbelts, vineyards) at relative distances of about 15 obstacle heights.
0.50 Very rough	"Old" cultivated landscape with many rather large obstacle groups (large farms, clumps of forest) separated by open spaces of about 10 obstacle heights. Also low large vegetation with small interspaces such as bush land, orchards, young densely-planted forest.
1.0 Closed	Landscape totally and quite regularly covered with similar-size large obstacles, with open spaces comparable to the obstacle heights; e.g. mature regular forests, homogeneous cities or villages.
≥ 2.0 Chaotic	Centres of large towns with mixture of low-rise and high-rise buildings. Also irregular large forests with many clearings.

(b) Ground Surface

Using appropriate roughness parameters is an essential component for accurate simulation of Atmospheric Boundary Layer (ABL) flow. The two types of roughness parameters, (i) aerodynamic roughness length z_0 and (ii) equivalent sand-grain roughness height k_s , should be applied on different surface areas as listed:

Ground Surface Area	Roughness Parameter
Area 1: From domain Inlet boundary to the boundary of explicitly modelled buildings	Aerodynamic roughness length z_0
Area 2: Within the region of explicitly modelled buildings	Aerodynamic roughness length z_0
Area 3: Within the site boundary of the development of interest	Equivalent sand-grain roughness height k_s

The region of inlet, approach and incident flow at the upstream of computational domain should be modelled with appropriate aerodynamics roughness length z_0 as well as the relationship between equivalent sand-grain roughness height k_s with the corresponding aerodynamics roughness length z_0 .

(c) Top and Lateral Surface of Domain

Use zero velocity gradients and zero normal gradients, i.e. “symmetry” condition, for all variables at the top and lateral surface when the top and lateral boundaries of the domain are far away enough from the buildings (refer to the requirements on the domain size).

(d) Outlet Surface of Domain

Use zero static pressure as the boundary condition at the outlet surface of computational domain.

(v) Discretization Schemes

In all circumstances, the users should attempt to apply 2nd order discretization schemes, which are preferred over 1st order discretization schemes to avoid numerical diffusion.

(vi) Convergence Criteria

To ensure the changes in solution variables from one iteration to the next are negligible, residuals with at least 4 orders of magnitudes shall be achieved. In addition, monitoring points should be defined in the region of interest and the velocities at those points should be recorded to ensure that the flow has reached steady values when simulation is converged properly.

(vii) Design Iteration

There shall be at least two iterations of simulation models to assess the wind flow conditions and air-flow pattern within the development to demonstrate the improvement in natural ventilation design. The simulation modeling can be conducted based on the two best prevailing wind directions for the building development that is North or North-East and South or South-East.

The naturally ventilated occupied spaces at the lowest level shall be selected for simulation. All naturally ventilated functional spaces at the selected floor are to be included in the simulation model except for enclosed spaces such as storerooms or CD shelters.

From the simulation results, the area-weighted average wind velocity of each simulated space shall be determined by considering the air flow conditions of the applicable areas. The area-weighted average wind velocities of these areas are to be computed at a horizontal-plane of 1.2 m above the floor level.

Thermal Comfort Simulation Methodology and Requirements

The thermal comfort assessment, where required, shall be carried out using Predicted Mean Vote (PMV) equation to identify the most effective building design and layout for the development. The assessment and simulation results and recommendations derived are to be adopted to meet the intent of the criteria.

For occupied spaces with natural ventilation performance unable to satisfy the minimum velocity prerequisites for the corresponding Green Mark ratings, mechanically assisted ventilation shall be provided and thermal comfort modeling shall be performed. The Predicted Mean Vote (PMV) shall meet the thermal comfort criteria for naturally ventilated spaces in tropical climate. Thermal comfort assessment shall be based on the PMV equation as follows:

$$PMV = a + b \times DBT + c \times WIND$$

Building Type	Value of a	Value of b	Value of c	Baseline of DBT(°C)
Industrial buildings	-4.974	0.202	-0.181	30
Healthcare facilities	-8.405	0.322	-0.686	30
Commercial atrium	-9.252	0.343	-0.747	31*
Hawker centres	-13.075	0.443	-0.460	32
Sport facilities	-9.945	0.379	-1.658	30
Schools	-6.805	0.267	-0.87	31

Note: The PMV value is to be rounded up to one decimal point.

Building Type	PMV Equation
Industrial buildings	$PMV = -4.974 + 0.202 \text{ DBT} - 0.181 \text{ WIND}$
Hospitals	$PMV = -8.405 + 0.322 \text{ DBT} - 0.686 \text{ WIND}$

Note: The PMV value is to be rounded up to one decimal point.

Where

DBT: Indoor air temperature (°C). The baseline of DBT is 30°C.

*DBT value for commercial atrium can be derived from the result of simulation that considers solar radiation, thermal load from human and equipment for event.

WIND: Indoor wind velocity (m/s). The value shall be derived from the result of indoor ventilation simulation via the Ventilation Simulation Methodology and Requirements in this annex. Natural ventilation simulation with fan modeling can be performed based on occupied spaces alone, without the inclusion of external domain with prevailing wind flow condition.

IAQ Methodology and Requirements

The Air Quality simulation shall be carried out using computational fluid dynamics (CFD) modeling to identify the most effective building design and layout for the development. The assessment and simulation results and recommendations derived are to be adopted to meet the intent of the criteria. This option is only applicable for sports facilities and industrial buildings with occupancy densities less than 50m² per person.

(i) Air Change Rate

The air change rate calculation shall be calculated based on the following equation:

$$ACH = \frac{3600 Q}{Vol}$$

Where

Q: Air flow through the occupied spaces (m³/s), determined from the result of indoor ventilation simulation via the Ventilation Simulation Methodology and Requirements in this annex

Vol: Volume of the room (m³)

Air Exchange Effectiveness (AEE)

In addition to ventilation simulation, species transport modeling shall be performed based on steady state. The tracer gas is recommended to be released through constant volume dosing within the occupied spaces of the natural ventilated building. In order to avoid the impact of gravity on the concentration distribution, the molecular weight of the injected tracer gas should be similar to air. The calculation of air exchange effectiveness shall be based on the concentration of tracer gas within the occupied spaces following the rule of mass balance.

The AEE shall be calculated based on the following equation:

$$\varepsilon_a = \frac{1}{\sum A_i} \frac{\sum C_{i,out} A_i}{C_{eq}}$$

Where

ε_a : Air exchange effectiveness

A_i : Face element area at the out-flow openings

$C_{i,out}$: Concentration of tracer gas in the outflow air

C_{eq} : Average tracer gas concentration in the room when steady state is reached, which represents the equilibrium conditions

Wind Driven Rain Methodology and Requirements

If the project is targeting to score for Wind driven rain (WDR) simulation under *Advanced Green Efforts*, WDR shall be carried out to identify and to reduce the severity of rain penetration into functional spaces of the development. Four different raindrop sizes are to be analyzed. From the simulation results, the depth of rain penetration (measured from the fenestration opening) into the functional spaces of the development shall be determined, and the most effective mitigation method to reduce the severity of rain penetration without manual behavioural intervention identified. The simulation results and recommendations derived are to be adopted to meet the intent of the criteria if points are to be scored.

Green Mark points = Overall WDR points x Multiplier

The severity of rain penetration into functional spaces (per analysed wind direction) may be broken down into the following 3-scale rating system as follows:

	Depth of rain penetration						WDR Points
	Industrial Building	Healthcare facilities	Commercial atrium	Hawker centre	Sports Facility	Schools	
1. Very good (no noticeable penetration of WDR)	≤ 0.20 m	≤ 0.10 m	≤ 2.00 m	≤ 1.60 m	≤ 1.60 m	≤ 0.50 m	1.0 pt
2. Good (some but acceptable degree of penetration of WDR)	≤ 0.40 m	≤ 0.20 m	≤ 4.00 m	≤ 3.00 m	≤ 3.20 m	≤ 0.90 m	0.9 pt
3. Moderate (substantial penetration of WDR, barely acceptable)	≤ 0.75 m	≤ 0.30 m	≤ 6.00 m	≤ 4.40 m	≤ 4.80 m	≤ 1.40 m	0.8 pt

	Industrial Building	Others	WDR Points
--	---------------------	--------	------------

4. Very good (no noticeable penetration of WDR)	Depth of rain penetration ≤ 0.20 m	Depth of rain penetration ≤ 0.10 m	1.0 pt
5. Good (some but acceptable degree of penetration of WDR)	Depth of rain penetration ≤ 0.40 m	Depth of rain penetration ≤ 0.20 m	0.9 pt
6. Moderate (substantial penetration of WDR, barely acceptable)	Depth of rain penetration ≤ 0.75 m	Depth of rain penetration ≤ 0.30 m	0.8 pt

The multiplier takes into account of the frequency of WDR occurrence which is broken down into the following 3-scale rating system as follows:

	Return Period	Multiplier
1. Type 1 Rain (no WDR risk)	Return Period ≤ 2 months	0.8
2. Type 2 Rain (low WDR risk)	Return Period ≤ 6 months	0.9
3. Type 3 Rain (high WDR risk)	Return Period > 6 months	1.0

The methodology will use the CFD methodology outlined within the section on *Ventilation Simulation Methodology and Requirements* and adapt it to the following requirements as highlighted below:

(ii) Software

The software shall be also be capable of second-order discretization schemes with Lagrangian particle tracking.

(iii) Boundary Condition & Turbulence Modeling

(a) Inlet Atmospheric Boundary Condition

The inbound vertical wind profile shall be assumed to be given by the Logarithmic Law with reference height at 15.0 m. The prevailing wind condition during raining period such as the wind velocity magnitude of different return periods for Singapore shall be based on NEA 32-year data at a reference height of 15.0 m as follows:

Wind Direction [deg]	NORTH 000°	NORTH-EAST 045°	EAST 090°	SOUTH-EAST 135°	SOUTH 180°	SOUTH-WEST 225°	WEST 270°	NORTH-WEST 315°
Return Period (months)	Wind Velocity (m/s)							
1	2.9	3.8	4.4	4.5	4.4	3.5	3.4	3.0
2	3.9	4.9	5.0	5.2	5.2	4.4	4.1	3.6
3	4.8	5.8	5.5	5.9	5.8	5.2	4.8	4.1
4	5.4	6.3	5.9	6.3	6.3	5.7	5.2	4.4
6	6.2	7.1	6.3	6.8	6.8	6.3	5.7	4.8
9	7.0	7.8	6.7	7.3	7.4	7.0	6.3	5.2
12	7.5	8.4	7.0	7.7	7.8	7.4	6.6	5.5

(b) Rain Drop Size

Four different raindrop sizes shall be analysed, and the respective terminal velocity (V_{terminal}) of different raindrop sizes are as follows:

Raindrop Diameter [mm]	V_{terminal} (m/s)
0.5	-2.0
1.0	-4.0
2.0	-6.5
5.0	-9.0

(c) Drag Coefficients

The drag coefficients for the raindrops (C_d) is a function of the relative Reynolds number (Re) and shall be taken from the table as follows:

Re (-)	C_d (-)
1.80	15.0
9.61	4.20
23.4	2.40
43.2	1.66
68.7	1.28
98.9	1.07
134.0	0.926
175.0	0.815
220.0	0.729
269.0	0.671
372.0	0.607
483.0	0.570
603.0	0.545
731.0	0.528
866.0	0.517
1,013.0	0.504
1,164.0	0.495
1,313.0	0.494
1,461.0	0.498
1,613.0	0.503
1,764.0	0.511
1,915.0	0.520
2,066.0	0.529
2,211.0	0.544
2,357.0	0.559
2,500.0	0.575
2,636.0	0.594
2,772.0	0.615
2,905.0	0.635
3,033.0	0.660
3,164.0	0.681
3,293.0	0.700
3,423.0	0.727
3,549.0	0.751

(d) Other Settings

Piecewise integration of raindrop equation of motion performed under Lagrangian Particle Tracking shall not be larger than 0.05 m length step size.

The injection location of raindrops shall be located inside the computational domain and outside the zone that is influenced by the buildings. The raindrops shall be released high enough to enable them to reach their terminal velocity of fall. It is recommended to use the following general rules to select the raindrop injection planes inside the computational domain:

- The width and length of the plane should be larger than that of the building of interest
- The vertical location of the plane depends on the velocities and raindrop diameters:
 - Higher velocities require a lower vertical location
 - Larger raindrops require a higher vertical location
- The horizontal location depends on the chosen height of the injection plane, the raindrop diameter and the reference wind velocity chosen for the simulation (recommended to be located at least 15H from the target building)

Guidance Notes

The following are guidance notes to help project teams keep track of their natural ventilation design and simulation progress.

Guidelines	Description/Selection	Response & Criteria
Submission Details		Provide the project details (especially information on natural ventilated design, building massing/orientation, GFA of natural ventilated spaces, % of opening & windows, credible source of site information with surrounding buildings, vegetation and terrain, future development etc.)
Building Type	Hospitals, schools, hawker centres, sports facilities, commercial atriums or industrial facilities	Describe building functionality, targeted natural ventilated spaces and occupants, transit area
Problem Statement	Objective & Work Scope	Describe natural ventilated challenges, proposed solution, desired outcome and work scopes from the simulation model. Whenever necessary, use the architectural drawing for explanation. Describe design stages and fix simulation details. Subsequent design change has to be supported by simulation results.
Site Information	Within 500m distance stream wise and span wise from the edge of development of interest	Describe the site information (including surrounding buildings, terrain, greenery), and illustrate how the geometrical info is incorporated into the simulation model (conversion process). Surrounding buildings within 500m distance stream wise and span wise from the edge of development of interest should be modelled explicitly; while the greenery can be modelled implicitly with tree canopy approach. Terrain effect can be ignored if elevation is less than 10m.

Guidelines	Description/Selection	Response & Criteria
CFD Approach	Simulation Methodology	The CFD solver shall have the minimum capability of solving the Navier-Stokes fluid flow equations for a three-dimensional incompressible flow at steady state. Turbulence modeling shall also be included with the minimum requirement of using the standard k- ϵ turbulence model, coupled with standard wall function
	Assumption & Simplification	Describe simulation model assumption, limitations and geometrical simplification. Whenever necessary, use the published literature data (including software manual) and comparison between architectural & CFD model for explanation
CFD Domain	Computational Domain	Describe the domain decomposition methodology; and relevant meshing type for each domain within the site. Describe the domain that be modelled implicitly with Davenport Roughness classification
CFD Meshing	Mesh independence study	To perform mesh independence study for natural ventilated occupied spaces
	Mesh size, distribution and quality	To carry out proper domain decomposition. To use hexahedral cells in the rectangular domain of NV space. Tetrahedral cells can be used to model the surrounding site features of the NV space. Hybrid pyramid or cut-cell mesh can be adopted at the interface. For implicit modeling of terrain roughness effect, prismatic or hexahedral cells is recommended to be used. As a guide, the dimension of the computational mesh should be set at 0.1 to 0.5 m within the functional space of interest, 0.5 to 1.0 m for building of interest and 1.0 - 5.0 m for surrounding buildings. The computational element size in vertical direction should be set at 0.5 - 1 m from ground surface to 10m height; followed by 1 - 5m to H_{max} height. Reporting on skewness and aspect ratio of the mesh is required.
CFD Model	Atmospheric Boundary Layer	<ol style="list-style-type: none"> To ensure horizontal ABL homogeneity in upstream and downstream To ensure sufficiently high mesh resolution in vertical direction near ground (e.g. height of first cell < 1m) To know the relationship between equivalent sand-grain roughness height (k_s) and corresponding aerodynamic roughness height, z_0 To ensure first cell center point (y_p) to be larger than physical roughness height (k_s)
	Buoyancy	To use Boussinesq or variable density and check gravity direction, if thermal simulation is performed.
	Turbulence model	To use the steady Reynolds-Average Navier Stokes (RANS), with minimum requirement k- ϵ turbulence model equation for NV flow.
CFD Boundary Conditions	Inlet wind profile	To ensure the vertical profile for wind velocity and turbulence in the ABL should be modelled by assuming constant shear stress with height.

Guidelines	Description/Selection	Response & Criteria
	Top & lateral sides of domain	To use zero velocity gradients and zero normal gradients of all variables.
	Outlet plane	To use zero static pressure.
	Window modeling	To use actual window opening size. Attach window schedule and drawing for verification.
	Mechanical fan modeling	To use fan input with appropriate swirl radial and swirl flow components.
	Louver modeling	To use simplified porous zone with appropriate pressure drop components and directional effect.
	Heat source modeling	To use aggregated heat load from heat dissipating devices, such as cooking stalls for hawker center facilities, heat generators for industrial facilities and etc.
CFD Numerical	Discretization scheme	To use 2 nd order for momentum equations
	Convergence criteria	To ensure solution is converged and monitored points at functional space reach steady values
User		Training, experience, consult expert
Documentation		Full documentation of parameters, readable scale
Design Iteration	Baseline case Modified case Optimal case	Baseline case – fixed building massing and layout Modified case – to highlight improvement on NV design Optimal case – final design with incorporation of NV features or passive innovative ideas

Documentation Requirements

Design Stage

The Qualified Person (QP) and the other appropriate practitioners shall ensure that the following report and building 3D model are available as evidences to demonstrate compliance with the ventilation simulation framework. The report should comprise the following items:

2.0 Cover page with a proper title, design image of development, developer's information (including developer's name and address and person-in-charge), consultant's detail (including the principal's name and authorized signature, firm's address and person-in-charge)

3.0 Table of Contents

4.0 Executive Summary

- Background of the development
- Main findings
- Concluding remarks

5.0 Background/ Introduction

- Building and site information
- Design strategies
- Detail of natural ventilation spaces (location, area, window to wall ratio etc.)

6.0 Methodology

- Describe methodology used in the study

7.0 Geometrical Model

- Isometric view of the development from various angles
- Domain size used
- Plan and 3D isometric model of units from various angles

8.0 Simulation settings

- Boundary conditions
- CFD software/ models used/ numerical scheme
- Mesh / cell sizing
- Solution control-convergence criteria

9.0 Result and Discussions

- Simulation results for the development for all directions showing the main graphical plots of the plan pressure and velocity vector and salient findings
- Tabulation showing the listing and details of all simulated NV spaces and the area-weighted average wind velocity within each simulated space where applicable

10.0 Conclusion

11.0 Appendix: The following plots are to be placed in the appendices:

- Simulation results for the development for each direction
 - Static pressure (plan view-ground & mid elevation and at the level of simulated NV space, isometric views on building façade)
 - Velocity vector and contour showing the plan view at ground & mid elevation and at the level of simulated NV space, and a few isometric sectional cut plans to show air-flow patterns across the development
- Simulation results for the natural ventilated spaces for each direction
 - Static pressure (plan view at the level of simulated NV space)
 - Velocity vector and contour showing the plan view at the level of simulated NV space, and a few isometric sectional cut plans to show air-flow patterns across the NV space

If thermal comfort modeling or air quality assessment is attempted, a corresponding chapter in the report shall be added to show the relevant calculations.

If WDR simulation is carried out, a chapter in the report shall be added to show the results of Wind Driven Rain penetration under different wind directions and the calculation of green mark points for WDR performance. The report also shall contain the following information:

- Injection location of the raindrop into the computational domain (plan and sectional views)
- Raindrop trajectory into functional spaces (plan and sectional views)
- Tabulation showing the listing and details as well as the corresponding depth of rain penetration of all occupied spaces where applicable.

Verification Stage

- The project team shall declare if any changes had been made in actual built layout compared to the submitted 3D ventilation simulation model in the design stage. The re-assessment of ventilation simulation will depend on the extent of changes and their impacts on NV performance.
- If thermal comfort modeling assessment is attempted, the post occupancy survey on the thermal comfort level is required.

Annex B: Effective Daylighting Simulation and Pre-Simulated Daylight Availability Tables Methodology and Requirements

General

The extent of effective daylighting in buildings may be determined using the (i) simplified pre-simulated Daylight Availability tables for standard designs building and spaces, or (ii) through detailed daylighting simulations. Both of these methods are outlined in this appendix. The following terms are used in order to describe the lighting quality of the design of an entire building or a specific space:

- (a) **Daylit area:** Daylight Autonomy (DA) is a metric that describes the annual sufficiency of natural lighting levels in an indoor space relative to a desired illuminance level. The daylit area is defined as the unit area of space which has a daylight illuminance level meeting or greater than the code lux requirement (N lx) for more than 50% of the building's occupied hours, denoted by $DA_{N\text{ lx}, 50\%}$
- (b) **Overlit areas:** Useful Daylight Illuminance Exceeded (UDle) is a metric that describes the frequency of which daylight illuminance levels reach or exceed an acceptable threshold of 3000 lx. The overlit area is defined as the area of space where daylight illuminance levels are equal to or greater than 3000 lx for 10% or more of the building's occupied hours, denoted by $UDle_{3000\text{ lx}, 10\%}$. Overlit areas are likely to lead to increased potential for visual discomfort in a space. $UDle_{3000\text{ lx}, 10\%}$ may be also be expressed or calculated as $DA_{3000\text{ lx}, 10\%}$, its equivalent

Daylight Autonomy Requirements

The specific daylight autonomy requirements are detailed for the various types of occupied spaces:

S/N	Space Occupancy Type	Daylight Autonomy requirement per unit area of space
1	Offices and Institutional spaces where lux requirement is 500 lux	$DA_{500\text{ lx}, 50\%}$
2	Industrial, sports facilities, retail areas where lux requirement is 300 lux	$DA_{300\text{ lx}, 50\%}$
3	Hotel and residential style occupancy where lux requirement is 200 lux	$DA_{200\text{ lx}, 50\%}$

Note: The minimum lighting level is given by SS531 for non-residential type buildings and CP38 for residential type buildings

Overlit areas should not be counted as comfortably daylit for occupants. The total comfortable daylit area should be calculated as $UDle_{3000\text{ lx}, 10\%}$ subtracted from $DA_{N\text{ lx}, 50\%}$. The $DA_{N\text{ lx}}$ and $UDle_{3000\text{ lx}}$ are to be calculated using the following program-specific occupied periods:

- Hotels and residential-style occupancy: 7:00 AM to 10:00 AM and 4:00 PM to 7:00 PM every day of the year
- Others: 8:00 AM to 5:00 PM every day of the year

Buildings with a consistently unusual occupancy schedule may seek approval to pursue a custom occupancy period.

Note: The project is required to show that effectively daylit areas are integrated with automated lighting controls, i.e. the design and installation and operation of artificial lighting are integrated with the availability of daylighting to the space.

Project is required to show that effective mitigation strategies are provided to spaces found to have the risk of overlighting or are overlit.

Effective Daylighting Simulation Methodology

Buildings with unusual forms, double-height spaces, complex facades, top-lighting strategies, advanced daylight redirection systems or other specialized design strategies, should use the full detailed daylighting simulation method to quantify the availability of natural daylighting specific in terms of Daylight Autonomy (DA) requirement. The results and recommendations derived from the simulation are to be used for assessment of criteria requirement.

(i) Simulation Software

The computational modeling shall be carried out using well documented software that has the capability to carry out daylighting simulation as per the stipulated details and granularity of the methodology. A tool should be chosen that can accurately account for geometry and material properties of buildings for an annual, 8760-hour, lighting calculation while producing the $DA_{N\text{ lx}}$ and $UDI_{e_{3000\text{ lx}}}$ metrics. Simulation parameters should be chosen, regardless of the tool, which are capable of accurately representing the complexity of the interaction between light, geometry and material being considered. The tool should be capable of calculating enough bounces of light to represent the reflections of ambient light deep into the space. The following minimum parameters are recommended in Radiance and Daysim-based analysis engines:

Parameter Name	Command Line Shorthand	Value
Ambient bounces	-ab	6
Ambient divisions	-ad	1500
Ambient accuracy	-aa	0.1
Ambient supersamples	-as	500
Direct threshold	-dt	0

Below are examples (non-exhaustive) of acceptable simulation software tools. Most of these tools are interfaces to the Radiance and/ or Daysim lighting simulation engines.

Software Name	Plug-in for (if applicable)	Remarks
DIVA-for-Rhino	Rhinoceros 3D	
Ecotect	-	$UDI_{e_{3000\text{ lx}}}$ must be simulated separately as $DA_{3000\text{ lx}}$.
Groundhog	Sketchup	
IES-VE	-	
Ladybug	Rhinoceros 3D	$UDI_{e_{3000\text{ lx}}}$ must be simulated separately as $DA_{3000\text{ lx}}$.
Lightstanza	-	Availability of required output metrics should be verified.
OpenStudio	Sketchup	Results are only available as tabulated results, not spatial visualizations.
Sefaira	Sketchup & Revit	Availability of required output metrics should be verified.

SPOT	Excel	
VI-Suite	Blender	

(ii) Analysis Points and Sensor Grids

Sensor points for analysis should be placed in every space being analysed using a uniform grid where the spacing between adjacent sensors is no further apart than 60 cm. A 30 cm grid is recommended, and denser grids are permitted in the analysis. Analysis points that receive a maximum instantaneous lighting level of 1 lux throughout the year can be excluded from the analysis, presuming they are contained within an opaque object or non-daylit space such as a wall or closet.

(iii) Climate Data

All annual simulations should be run using hourly climate data input from IWECC weather data. The sky luminance distribution should be approximated at each hour using the Perez all-weather sky model, which is the default calculation mode in Radiance and Daysim-based annual climate-based analyses and for all of the tools listed in the simulation software section above.

(iv) Computational Domain

The computational domain for all simulations shall include the development of interest, the characteristics of the immediate surroundings and buildings at a large scale level. Generally, all relevant storey levels of each building tower together with the interior design layouts (such as walls and partitions) and properties of the following are to be considered in the simulation of daylighting and overlighting in occupied spaces. However, it is permissible to analyse typical rooms for each orientation and urban context of the building and extrapolate those results to the entire built floor area using individual room data.

(v) Materials and Objects

3D models of buildings and occupied spaces should be modelled with appropriate geometric complexity, being as close to 'as-built' as possible including the physical form, placement of windows, mullion details, thickness of opaque building components, exterior and surrounding obstructions and material properties. Interior partitions and exterior walls should be modelled accurately and with their intended thicknesses. The floor-to-ceiling height should be accurate and account for architectural finish details such as dropped ceilings. Some aspects to highlight are as follows:

a) Exterior Obstructions and Shading Devices

Exterior obstructions within a distance of 40 m from the building façade being studied, which will cast shadows and reflect light, shall be modelled, e.g. louvers, overhangs, fins and balconies, exterior buildings. Exterior buildings adjacent to the site shall be modelled within 4 m of geometric accuracy. Trees may be modelled as appropriately dimensioned cones or spheres with material properties.

b) Furniture and Partitions

When a furniture design is known, furniture surfaces and half-height partitions (cubicle walls, for example) that are higher than 90 cm above the finished floor height shall be modelled within 15 cm of geometric accuracy.

c) Skylight and Window Details

Skylight and window details greater than 5 cm in any direction, including sills, jambs, sashes and mullions shall be modelled in 3 dimensions, taking into account, the thickness of the wall or ceiling in which they are set, e.g. the skylight well (a vertical offset between its glazing surface and the ceiling). When the details of window

framings and skylights are not known, a 20% and 10% reduction to the visible transmittance of the glass (T_{vis} value of 0.45) may be applied respectively instead.

d) Small Details

Small details that will have little impact on the lighting distribution need not be modelled, e.g. door handles, HVAC diffuser grills, wall electrical panels, etc. An object should be modelled separately when it is larger than 3 m², is parallel to and near a larger surface, and with material reflectance more than 20% from the surrounding surfaces,

e) Transmittance and Reflectance Properties of Materials

The transmittance and reflectance properties of materials shall be defined based on measurements, construction finish specifications or glazing specifications where known. The value of the glazing visible light transmittance (T_{vis}) shall be extracted from the glazing specifications used for the project, such as in ETTV calculation. Otherwise, T_{vis} value of 0.45 (transmissivity of 0.491) may be used for glass materials. For reflectance values, the following default values may be used:

Materials		Reflectance Value
Wall or partition		0.70
Floor	Carpet	0.20
	Tiles	0.40
	Plasters	0.70
Furniture	Any type	0.50
Ceiling	Any type	0.80
Roof	Any type	0.10
Exterior	Asphalt pavement	0.10
	Grass	0.20
	Tree	0.20
	Paving blocks	0.30
	Building facades	0.35
	Stainless steel	0.85
	Swimming pool water	0.90

(vi) UDle and Potential for Overlighting

Building spaces with $UDle_{3000\text{ lx}, 10\%}$ covering 15% or more of the floor area in a simulation-based or exceeding 1.3 m depth of penetration measured from the façade using the pre-simulated tables are considered to be overlit and are considered not meeting the requirement for effective daylight.

In this case, design modifications and mitigation strategies for overlighting should be incorporated to reduce overlighting. For example, fixed shading devices can be added or the area of glazing reduced. Fully automated dynamic shading systems or operable light-redirecting systems critical to the daylighting performance of a space, as well as their realistic geometry and material properties can also be accounted for. This can be done in the simulation engine of choice using a geometric model as in the Daysim calculation engine or using a bidirectional scattering and distribution function (BSDF) as in the Radiance three-phase method.

Worked Example

Effective Daylighting Simulation

The below image represents an example calculation for the bottom floor of a stacked 4-story block with a courtyard and presumed office-type lighting requirement and occupancy profile (500 lux from 8:00 AM to 5:00 PM). The results shown are from a single annual illuminance calculation, which is visualized such that areas with $DA_{500\text{ lx}, 50\%}$ and $UDI_{e3000\text{ lx}, 10\%}$ are shown using a gradient colour scale from blue ($DA_{500\text{ lx}, 50\%}$) to yellow ($DA_{500\text{ lx}, 75\%}$) to red ($DA_{500\text{ lx}, 100\%}$). Areas that are overlit with $UDI_{e3000\text{ lx}} > 10\%$ of occupied hours are displayed in pink, and non-daylit areas with $DA_{500\text{ lx}} < 50\%$ of occupied hours are displayed in grey. The analysis of the spatial percentages of this floor area indicate that $DA_{500\text{ lx}, 50\%}$ is achieved in 58.37% of occupied spaces without being overlit. Overlit areas, $UDI_{e3000\text{ lx}, 10\%}$, account for 10.85% of occupied spaces due to the relatively significant East and West glazing.

An example composite results view of a daylighting calculation. The analysis is of the bottom floor of a 4-storey office block using a 25 cm spacing sensor grid.

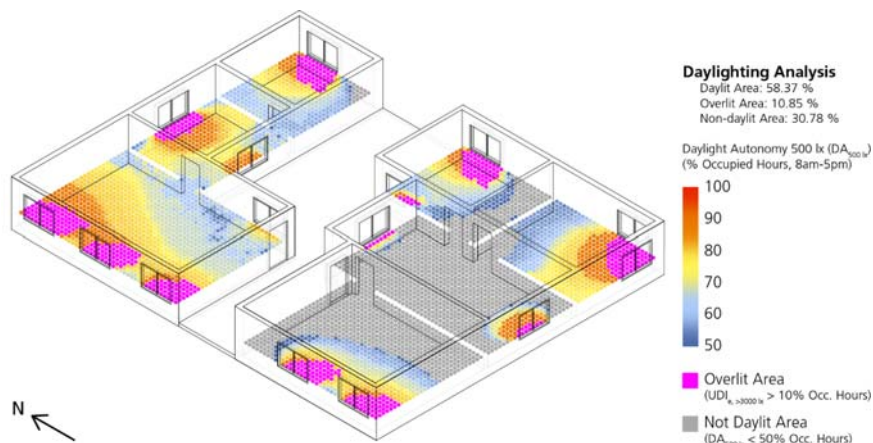

Besides a plan-based visualization of the results, values should be tallied on a room-by-room basis using an implement such as the table below, which is keyed to the representative floor plans, in this case by room numbers. Any space with greater than 15% overlit area should be removed from the whole-building daylit area calculations. In the table below, column values not included in whole-building calculations due to being in an overlit space are coloured red.

Floor	Room #	Total Area (m ²)	Daylit Area (m ²)	Overlit Area (m ²)	Comfortable Daylit Area (m ²)	Overlit Area (%)	Comfortable Daylit Area (%)
1	1	72.1	72.1	11.4	60.7	15.8	84.1
1	2	26.5	26.5	2.5	24.0	9.3	90.7
1	3	24.5	23.6	3.5	20.1	14.1	82.1
1	4	60.1	27.6	6.1	21.5	10.2	35.7
1	5	55.6	8.4	1.1	7.3	2.0	13.1
1	6	29.3	20.7	3.9	16.8	13.2	57.3
1	7	33.0	30.2	4.5	25.7	13.6	77.8
Total		301.1	137.0	33.0	115.4	11.0	38.3

*Note: Red values not used in column summations due to room being >15% overlit.

Overall, 11% of the floor area is overlit, and 38.3% is comfortably daylit.

While the composite visualization above is an efficient way of displaying the pertinent simulation results for Green Mark qualification, it is acceptable to show simulated results in multiple steps. For example, a practitioner might plot the results of $UDI_{3000\text{ lx}}$ separately from those of $DA_{500\text{ lx}}$ and perform the area calculations separately, subtracting the overlit area from the underlit area in each given space and checking that the overlit area is less than 15%. Example visualizations using this method are included below:

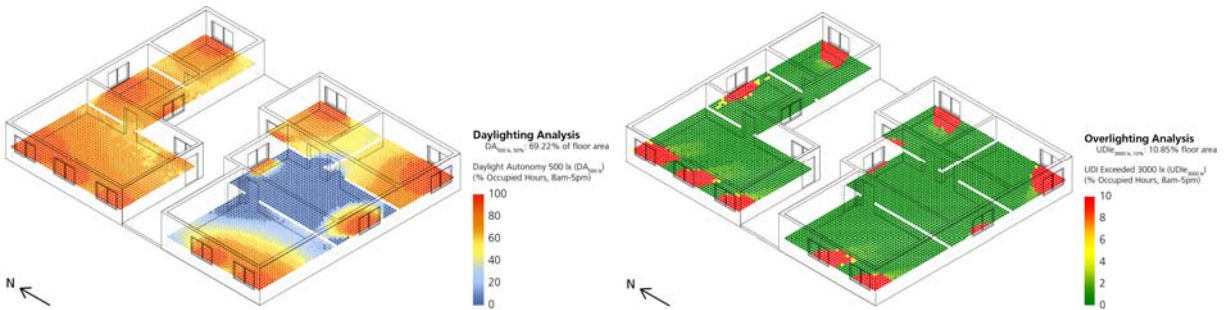

Example separated results views of $DA_{500\text{ lx}}$ and $UDI_{3000\text{ lx}}$ calculations.

Pre-Simulated Tables and Methodology for Standard Designs

The Pre-Simulated Daylight Autonomy tables were derived from more than 4,000 simulated results using a reference shoebox model. The tables can be used as a simplified method to determine the comfortable daylighting for each space. They are suitable for use for spaces with standard designs in the Space Occupancy Type listed. The tables may be found at the following link:

https://www.bca.gov.sg/GreenMark/others/GMNRB2015_Daylight_Availability_Tables.pdf

Standard designed spaces are defined by the following building characteristics and urban parameters:

- Spaces with simple façade designs that can be described by orientation, window-to-wall ratio (WWR), and glazing visible light transmittance (T_{vis})
- Spaces with typical room floor-to-ceiling heights between 2.5 m and 3.1 m
Note: In spaces with different ceiling heights, the depth of daylight penetration would naturally change due to different contributions from the ceiling. Such cases may wish to consider using a full simulation in order to show the daylit area more accurately.
- Spaces with simple horizontal overhang shading devices or no shading devices
- Relatively unobstructed spaces with average urban obstruction angles $\leq 57.25^\circ$

The tables display results from pre-simulation daylight autonomy of spaces for the respective occupied hours stipulated for the specific Space Occupancy types. There are 3 associated pre-simulated tables for each Space Occupancy type representing differing levels of obstruction from the urban context. Each table contains 24 main blocks organized in a grid, each of which contain 60 smaller squares containing numerical values. The numerical values within each squares indicate the depth of comfortable daylight, defined as the depth of $DA_{\text{Nlx}, 50\%}$ measured from the façade subtract the depth of $UDI_{3000\text{ lx}, 10\%}$ (not exceeding 1.3m) measured from the facade. In this way, the tables represent an effective tallying of comfortable daylight penetration within a space—equivalent to the simulation-based methodology of subtracting $UDI_{3000\text{ lx}, 10\%}$ from $DA_{\text{Nlx}, 50\%}$; however, the distances indicated in the tables cannot be directly compared to simulated results.

Blue squares indicate designs which have minimal overlighting risk ($UDI_{e_{3000\text{ lx}, 10\%}} < 1.3\text{ m}$ from the façade), whereas red and pink squares indicate depths of daylight which are at risk of being overlit or overlit ($UDI_{e_{3000\text{ lx}, 10\%}} \geq 1.3\text{ m}$ or 2.0 m from the façade). Spaces which are at risk of overlit (red squares) or spaces overlit (pink squares) will be deemed not complied with the daylight requirement, as such, the areas are not to be counted as part of the daylight area. The numerical values for the red or pink squares are not provided.

Using the Pre-simulated Tables has its benefits for projects at conceptual design stage, as the designers may consider varying the design parameters or shading provision to provide spaces with comfortable daylight condition. The Pre-Simulated Tables can be used as a simple and quick design guide for this purpose.

Alternatively, designers could incorporate mitigation strategies, such as, complex shading, opaque bottom-up blinds, translucent, adjustable venetian blind systems, etc. to address overlighting to the overlit spaces. A detailed simulation shall be carried out to show that the strategies is effective.

(i) Urban Context Obstructing Daylight

The Average Urban Obstruction Angle (AUOA) describes the average portion of sky blocked by surrounding obstructions opposite a façade, e.g. neighbouring buildings. It can be determined as follows:

$$AUOA = \arctan\left(\frac{H-h}{W}\right)$$

Where

H: Average urban height of the surrounding obstructions in meters measured from the ground

h: The height of the respective space's floor level above ground

W: Width of street, between the building and its surrounding obstructions.

The following diagram shows an example of the derivation of the average urban obstruction angle for the three floors of a building based on the average urban obstruction height of 15.5 m, the building-to-building distance of 20 m and the floor height of each level:

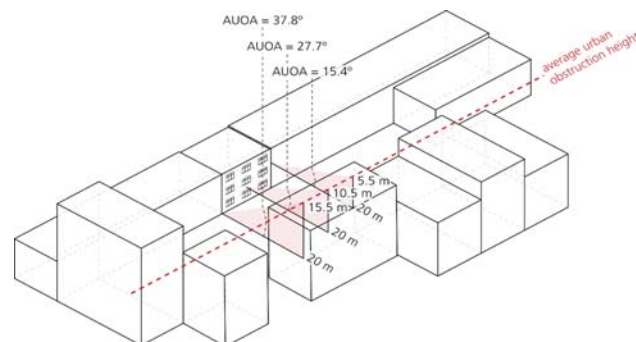

With the AUOA known;

select the chart with the appropriate "Degree Sky Obstruction" for use. The AUOA (Degree Sky Obstruction) are grouped into the following range; shown in three separate tables:

- AUOA of 0–11.25°- Relatively unobstructed spaces
- AUOA of 11.25–33.75°- Moderately obstructed urban contexts
- AUOA of 33.75–57.25°- Significantly obstructed urban contexts

(ii) Window-to-Wall Ratio (WWR)

There are 10 WWRs included in the pre-simulated daylight autonomy tables: 10%, 20%, 26%, 32%, 39%, 43%, 52%, 60%, 70% and 87%. The WWR value closest to the actual façade WWR from this list should be used.

(iii) Overhang Obstruction Angle (OOA)

The OOA is the angle describing the portion of sky blocked by a horizontal overhang. The angle is measured from the bottom of the window assembly, i.e. from the zenith (directly overhead) to the outside edge of the shading device.

$$OOA = \arctan\left(\frac{H_w}{P}\right)$$

H_w is the height of the windows of the space, while P is the length of the shading device.

The following diagram depicts the measurement of the overhang obstruction angle from the bottom window sill:

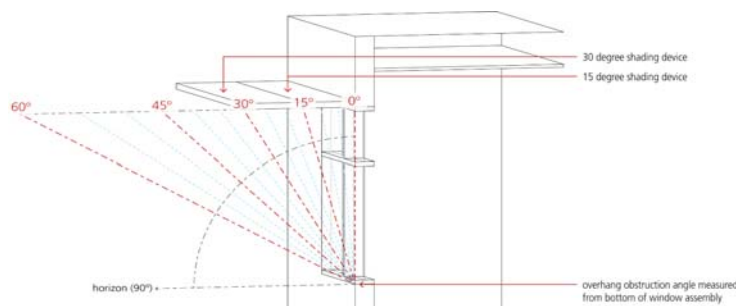

Within each Pre-Simulated Daylight Availability table, results are grouped in columns by the Overhang Obstruction Angle (OOA). There are three column groupings for OOA; i.e. 0°, 10° and 15°. The closest value to the actual project OOA value should be used.

(iv) Orientation

Within each table, each row grouping indicates one of the 8 major cardinal directions in which the façade is oriented. The façade orientation should fall within 11.25° of the chosen orientation from the tables.

(v) Visible Light Transmittance (T_{vis})

Within each grouping, results are ordered by T_{vis} along the vertical axis. Six T_{vis} values are represented in the pre-simulated Daylight Availability tables: 25%, 35%, 45%, 55%, 65% and 75%. A project's T_{vis} should be derived from window material specifications for the project, and the closest value to the represented T_{vis} should be chosen for use in the tables.

(vi) Limitations Regarding the Pre-Simulated Daylight Availability Tables

While the simplified Pre-Simulated Daylight Availability Tables effectively represents results for standard designs, there are limitations that should be considered when using them. Some of the considerations when using them are described as follows:

- Underestimation of lighting in spaces with opposing glazed façades: In spaces with windows on two opposing façades, the depth of daylight penetration would naturally increase due to contributions from opposing sides of the space. Such cases may wish to consider using a full simulation in order to increase their daylit area.
- Potential for double counting: If two glazed façades are located about a single corner, the daylit areas will overlap. The total daylit area in these cases should be calculated using a floor plan drawing in order to avoid double-counting

Worked Example

Pre-Simulated Tables and Methodology for Standard Designs

Building X is a small three-storey commercial office building. The building has three floors, with the height of the finished floor at 0 m, 3.5 m and 7.0 m above grade, with a floor-to-ceiling height of 2.8 m. Based on an average urban obstruction height of 10.5 m and a building-to-building distance of 20 m, its three South-facing façades have an AUOA of 27.7°, 19.3° and 9.9° as seen in the diagram below:

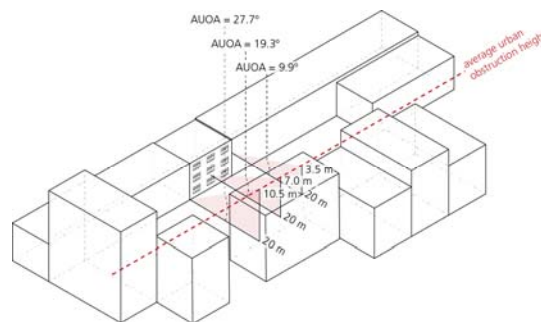

In the example WWR calculation, a representative section of façade is identified that spans vertically from the midpoint of each floor slab and is horizontally equidistant between identical windows. The vertical area of this representative façade section is 10.92 m². The façade section has 3 nos. of 0.264 m² and 3 nos. of 0.593 m² panes of glazing. This results in a WWR of 23.5%.

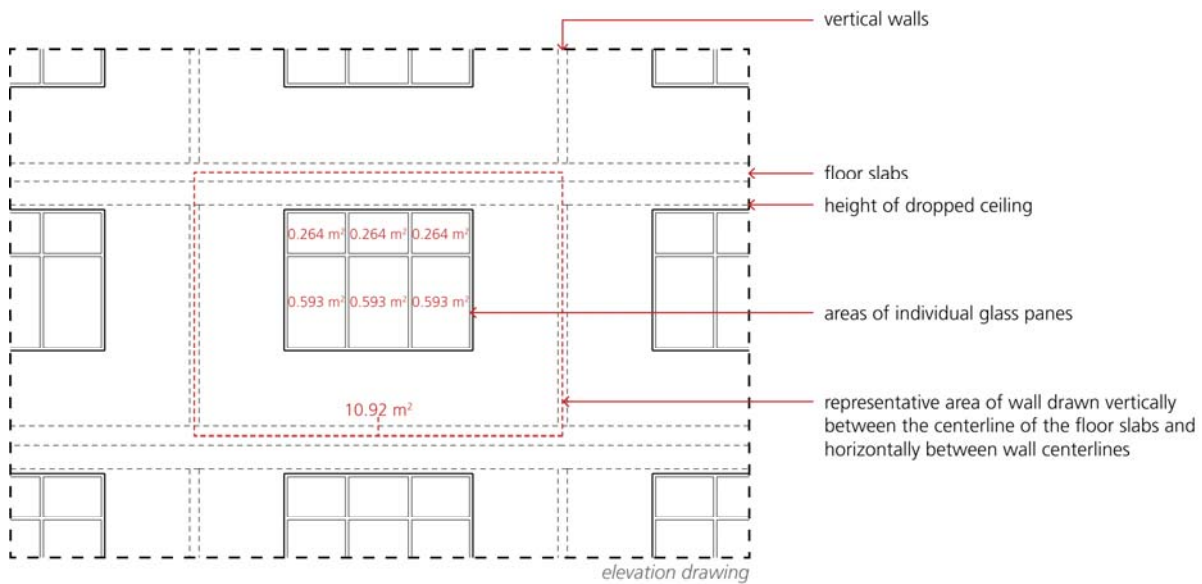

$$\text{WWR} = \frac{3 \times 0.264 + 3 \times 0.593}{10.92} \times 100 = 23.5\%$$

WWR is defined as the ratio of glazed area over the total wall area multiplied by 100

The following table indicates the building properties:

Floor	Urban Context	Shading	Orientation	WWR	T _{vis}
Floors 1-3	Unobstructed	0° (None)	North	20%	65%
Floor 1-2	11.25-33.75°	0° (None)	South	20%	65%
Floors 2-3	Unobstructed	0° (None)	South	20%	65%

Therefore, two Pre-Simulated Daylight Autonomy Tables for the DA500_{lx, 50%} lighting conditions will be used: the Table between 0 and 11.25° and between 11.25 and 33.75°. The following table illustrates the results extracted from the Pre-Simulated Daylight Autonomy Tables:

Floor	Comfortably Daylit Depth	Potential or Risk of Overlighting?
Floors 1-3 North	1.7 m	No
Floors 1-2 South	1.2 m	No
Floors 3 South	-	Yes

Note that Floor 3 South will be overlit and therefore cannot be included in the results unless the design is changed. Next, the results should be applied to the building floor plans. The space is a simple, open-plan rectangle with 11.4 m long daylit façades and is 10 m deep. Looking at the case of Floor 1 in detail, this means that from the North, 1.7 m x 11.4 m = 19.4 m² area is comfortably daylit. For the South bottom two floors, 1.2 m x 11.4 m = 13.7 m² area is comfortably daylit. The percentage of daylit area can be obtained by simply summing the daylit area from each façade and dividing by the total floor area. As an example, 33.1 m² / (11.4 m x 10 m) = 29.0% of Floor 1 is daylit.

These results should be tallied per floor.

- Floor 1: 33.1 m² Daylit
- Floor 2: 33.1 m² Daylit
- Floor 3: 19.4 m² Daylit (Southern portion overlit)

As a result, percentage of the building which is daylit as per the Pre-Simulated Method for Standard Designs is as follows:

$$\frac{33.1 \text{ m}^2 + 33.1 \text{ m}^2 + 19.4 \text{ m}^2}{3 \times 114 \text{ m}^2} = 25.0\%$$

The result (percentage of daylight spaces) is then used to refer to the Daylight criteria for eligibility of Green Mark points.

It is worth noting that in the case of this building design, daylight coming in from opposing façade was not able to be shown using the simplified method. The project team may want to consider a full simulation which is likely to show the higher daylit area.

Annex B2: Pre-Simulated Daylight Autonomy Tables

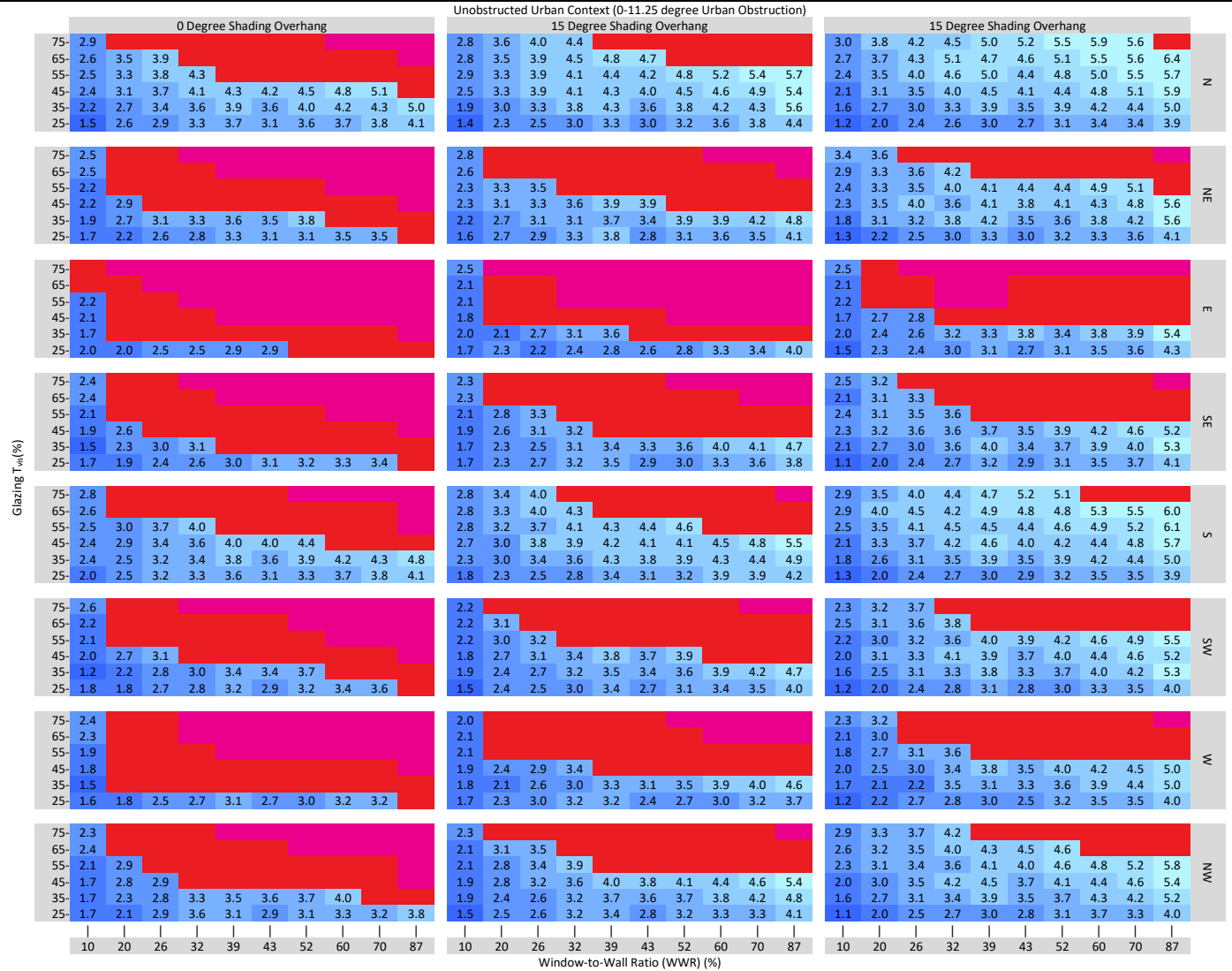

Unobstructed Urban Context for DA of 200 lux

Depth of DA_{200lux, 50%} daylight area minus UDLE_{3000lux, 10%} overlit area (commercial occupancy schedule)

- (0.00 to 1.50) m daylight depth
- (1.50 to 2.25) m daylight depth
- (2.25 to 3.00) m daylight depth
- (3.00 to 3.75) m daylight depth
- (3.75 to 4.75) m daylight depth
- (4.75 to 5.25) m daylight depth
- > 5.25 m daylight depth

- Potential Overlighting [1.3–2.0) m overlit depth
- Risk of Overlighting >=2.0 m overlit depth

Direction

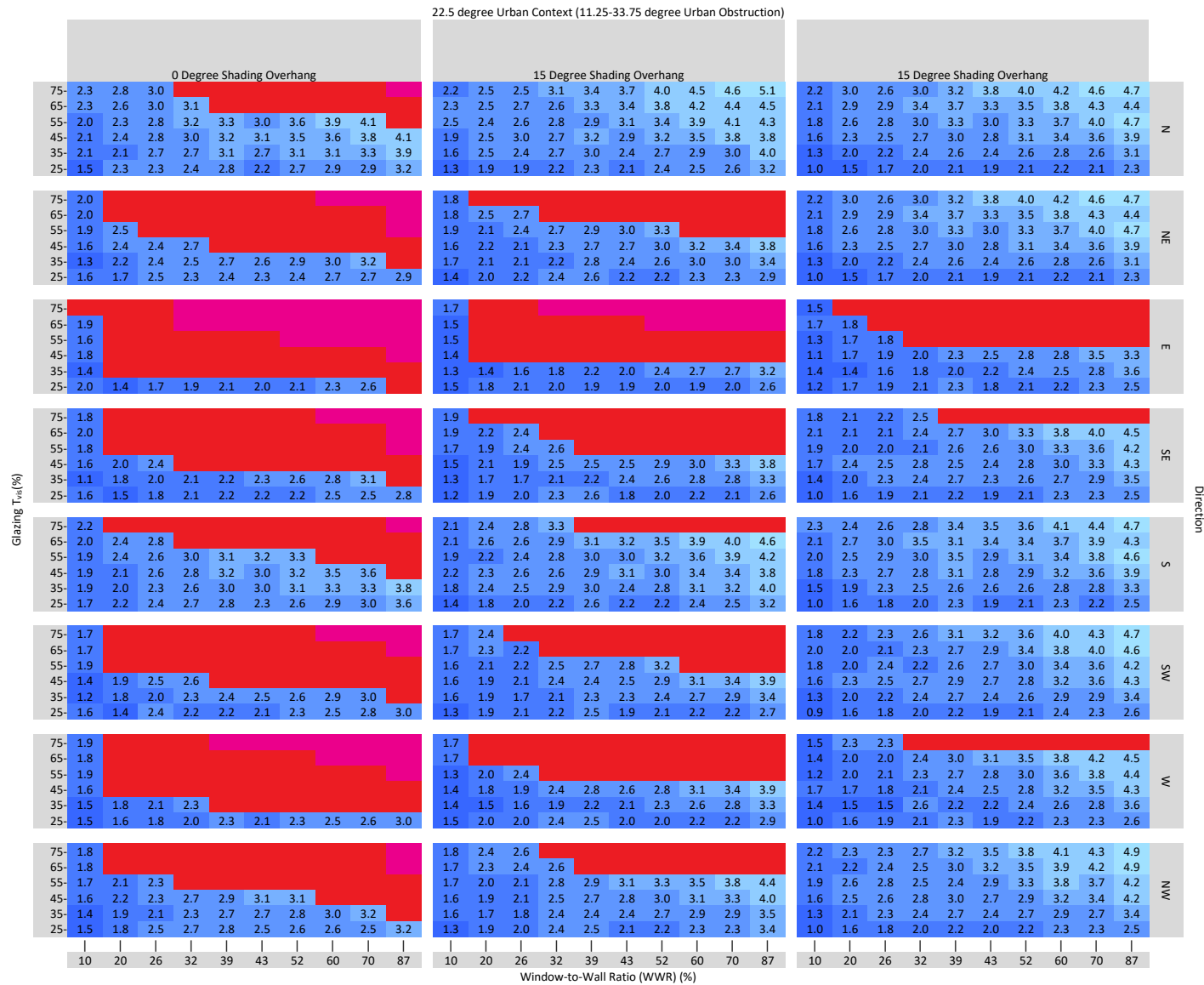

22.5 degree Urban Context for DA of 200 lux

Depth of DA_{200lux, 50%} daylight area minus UDL_{1000lux, 10%} overlit area (commercial occupancy schedule)

- (0.00 to 1.50) m daylight depth
- (1.50 to 2.25) m daylight depth
- (2.25 to 3.00) m daylight depth
- (3.00 to 3.75) m daylight depth
- (3.75 to 4.75) m daylight depth
- (4.75 to 5.25) m daylight depth
- > 5.25 m daylight depth

- Potential Overlighting [1.3-2.0] m overlit depth
- Risk of Overlighting ≥ 2.0 m overlit depth

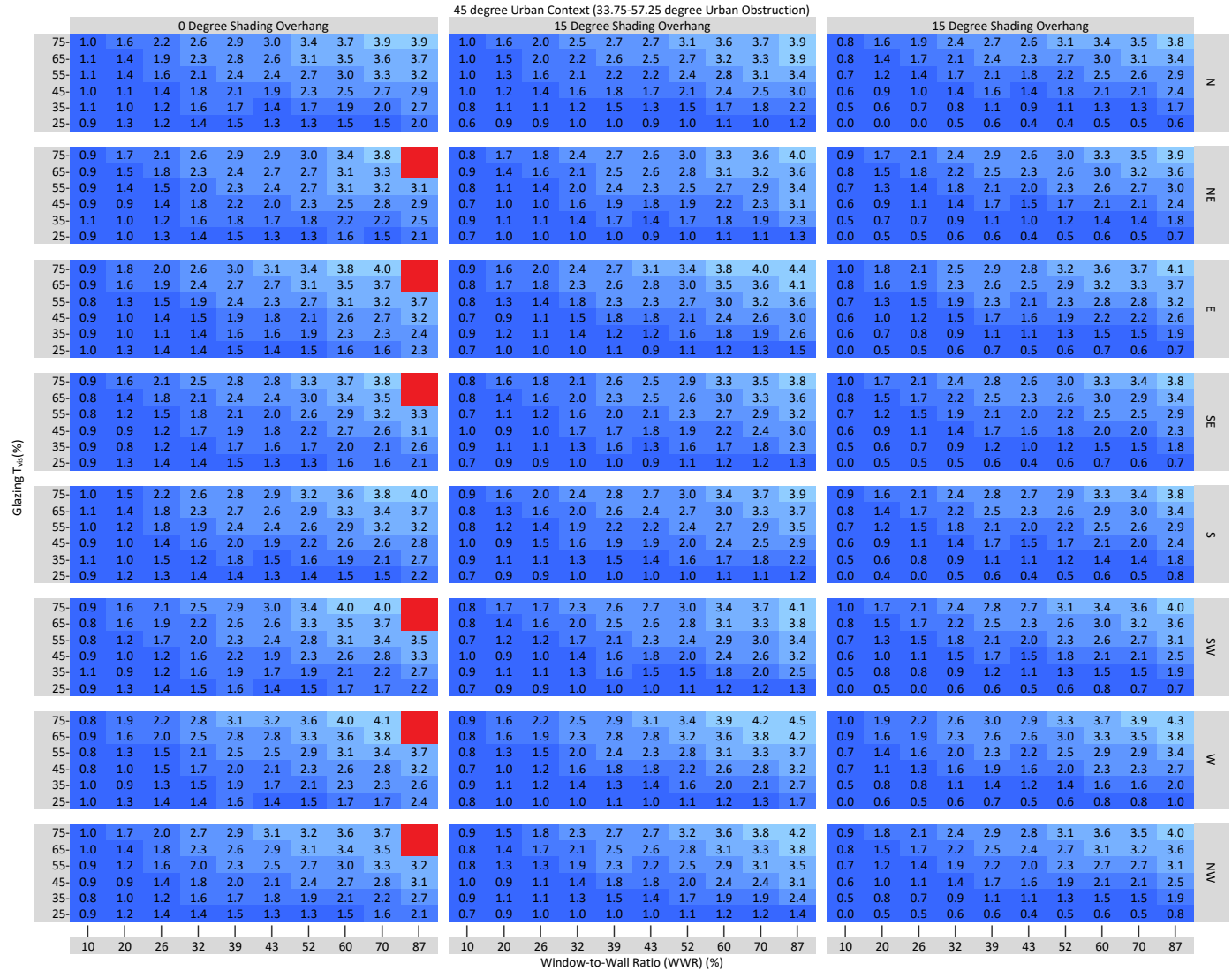

45 degree Urban Context for DA of 200 lux

Depth of $DA_{200lux, 50\%}$ daylight area minus $UDL_{E3000lux, 10\%}$ overlit area (commercial occupancy schedule)

- (0.00 to 1.50) m daylight depth
- (1.50 to 2.25) m daylight depth
- (2.25 to 3.00) m daylight depth
- (3.00 to 3.75) m daylight depth
- (3.75 to 4.75) m daylight depth
- (4.75 to 5.25) m daylight depth
- > 5.25 m daylight depth

Potential Overlighting [1.3-2.0) m overlit depth
Risk of Overlighting ≥ 2.0 m overlit depth

Unobstructed Urban Context for DA of 300 lux

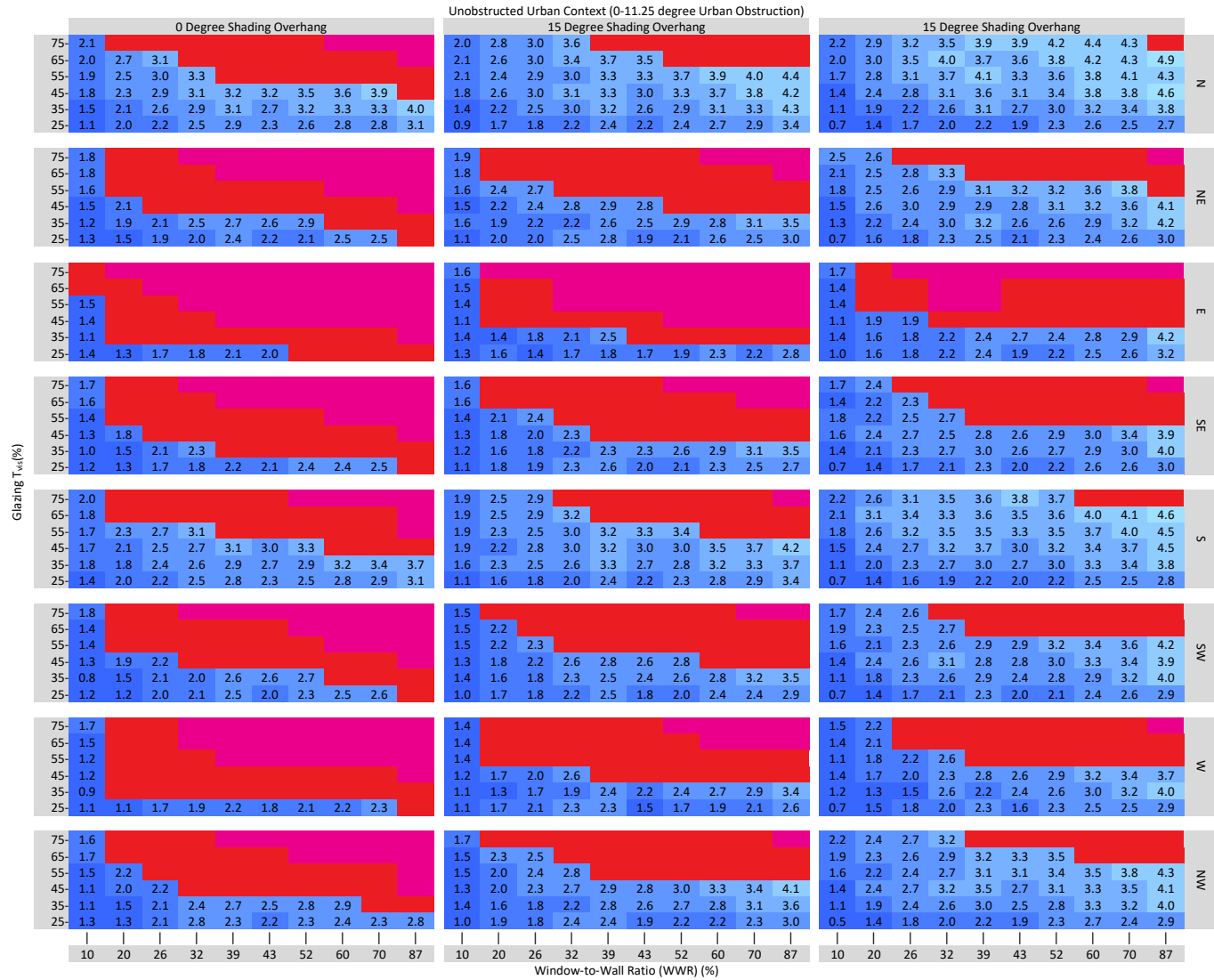

Depth of DA_{300lux, 50%} daylight area minus UDI_{E300lux, 10%} overlit area (commercial occupancy schedule)

- 0.00 to 1.50) m daylight depth
- (1.50 to 2.25) m daylight depth
- (2.25 to 3.00) m daylight depth
- (3.00 to 3.75) m daylight depth
- (3.75 to 4.75) m daylight depth
- (4.75 to 5.25) m daylight depth
- > 5.25 m daylight depth

- Potential Overlighting [1.3-2.0] m overlit depth
- Risk of Overlighting ≥2.0 m overlit depth

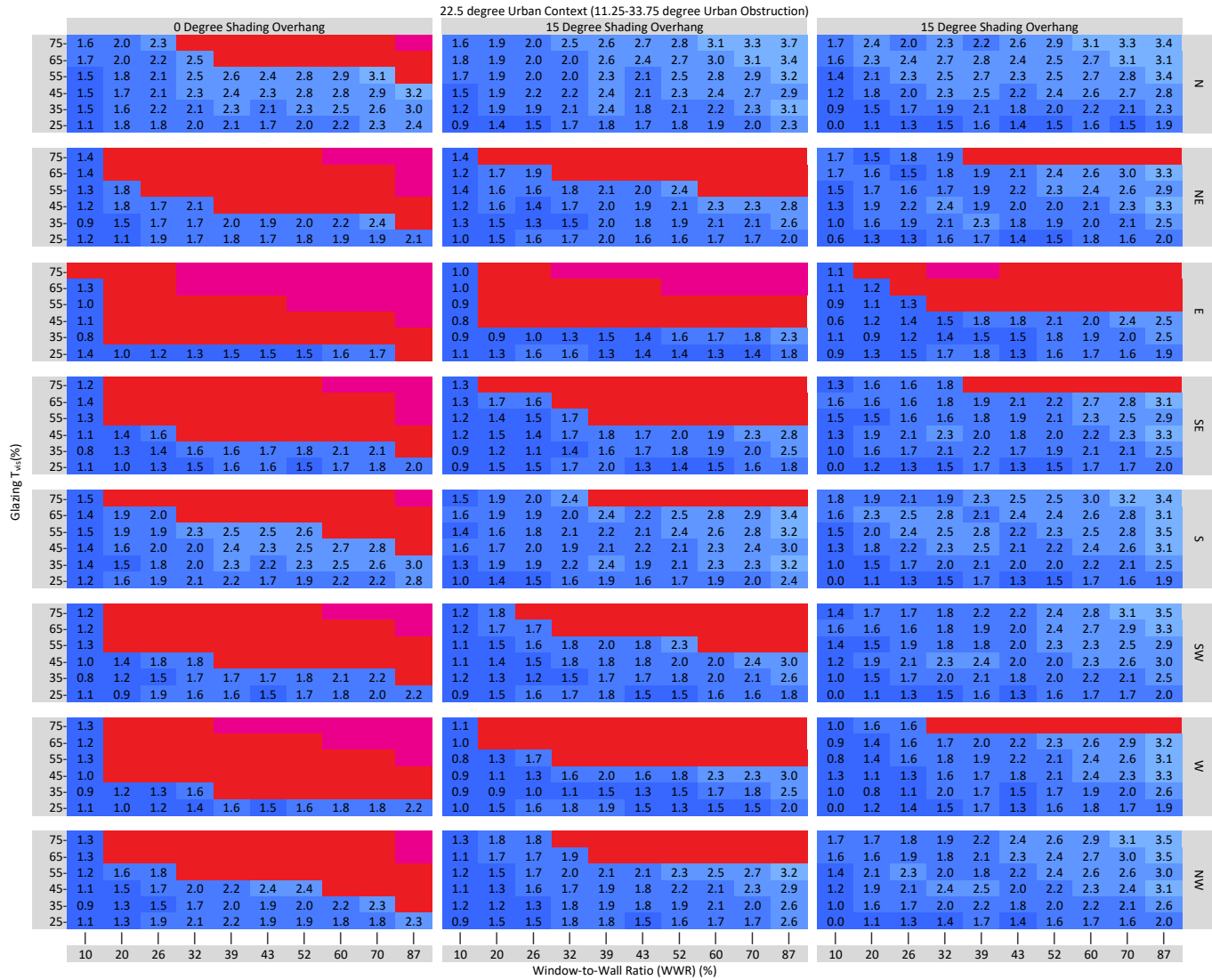

22.5 degree Urban Context for DA of 300 lux

Depth of DA_{200lux, 50%} daylight area
minus UDLE_{300lux, 10%} overlit area
(commercial occupancy schedule)

- (0.00 to 1.50) m daylight depth
- (1.50 to 2.25) m daylight depth
- (2.25 to 3.00) m daylight depth
- (3.00 to 3.75) m daylight depth
- (3.75 to 4.75) m daylight depth
- (4.75 to 5.25) m daylight depth
- > 5.25 m daylight depth

- Potential Overlighting [1.3-2.0] m overlit depth
- Risk of Overlighting >=2.0 m overlit depth

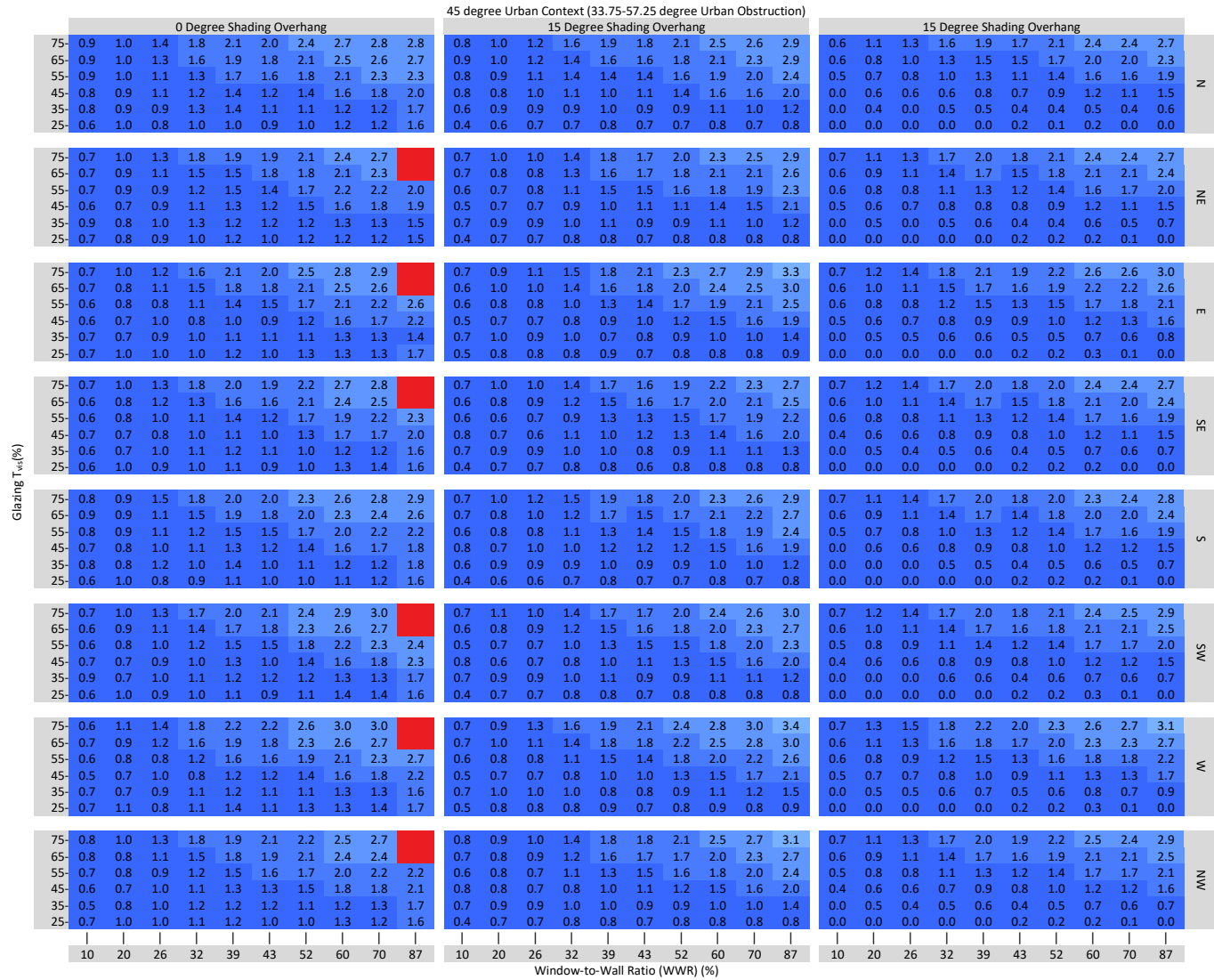

45 degree Urban Context for DA of 300 lux

Depth of DA_{300lux, 50%} daylight area minus UDIE_{300lux, 10%} overlit area (commercial occupancy schedule)

- 0.00 to 1.50) m daylight depth
- (1.50 to 2.25) m daylight depth
- (2.25 to 3.00) m daylight depth
- (3.00 to 3.75) m daylight depth
- (3.75 to 4.75) m daylight depth
- (4.75 to 5.25) m daylight depth
- > 5.25 m daylight depth

- Potential Overlighting [1.3-2.0) m overlit depth
- Risk of Overlighting ≥ 2.0 m overlit depth

Direction

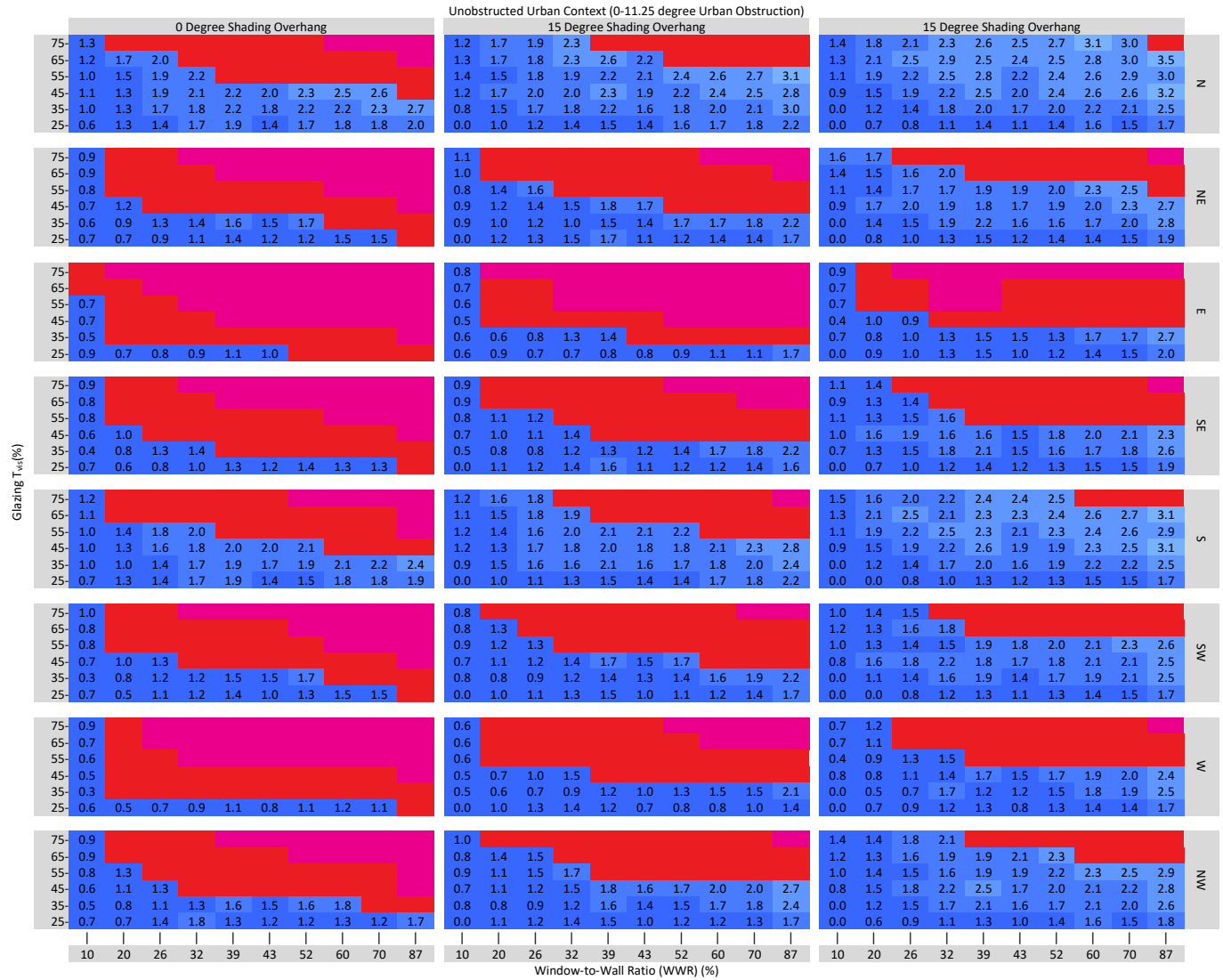

Unobstructed Urban Context for DA of 500 lux

Depth of DA_{500lux, 50%} daylight area
minus UDI_{E3000lux, 10%} overlit area
(commercial occupancy schedule)

- (0.00 to 1.50) m daylight depth
- (1.50 to 2.25) m daylight depth
- (2.25 to 3.00) m daylight depth
- (3.00 to 3.75) m daylight depth
- (3.75 to 4.75) m daylight depth
- (4.75 to 5.25) m daylight depth
- > 5.25 m daylight depth

- Potential Overlighting [1.3-2.0] m overlit depth
- Risk of Overlighting >=2.0 m overlit depth

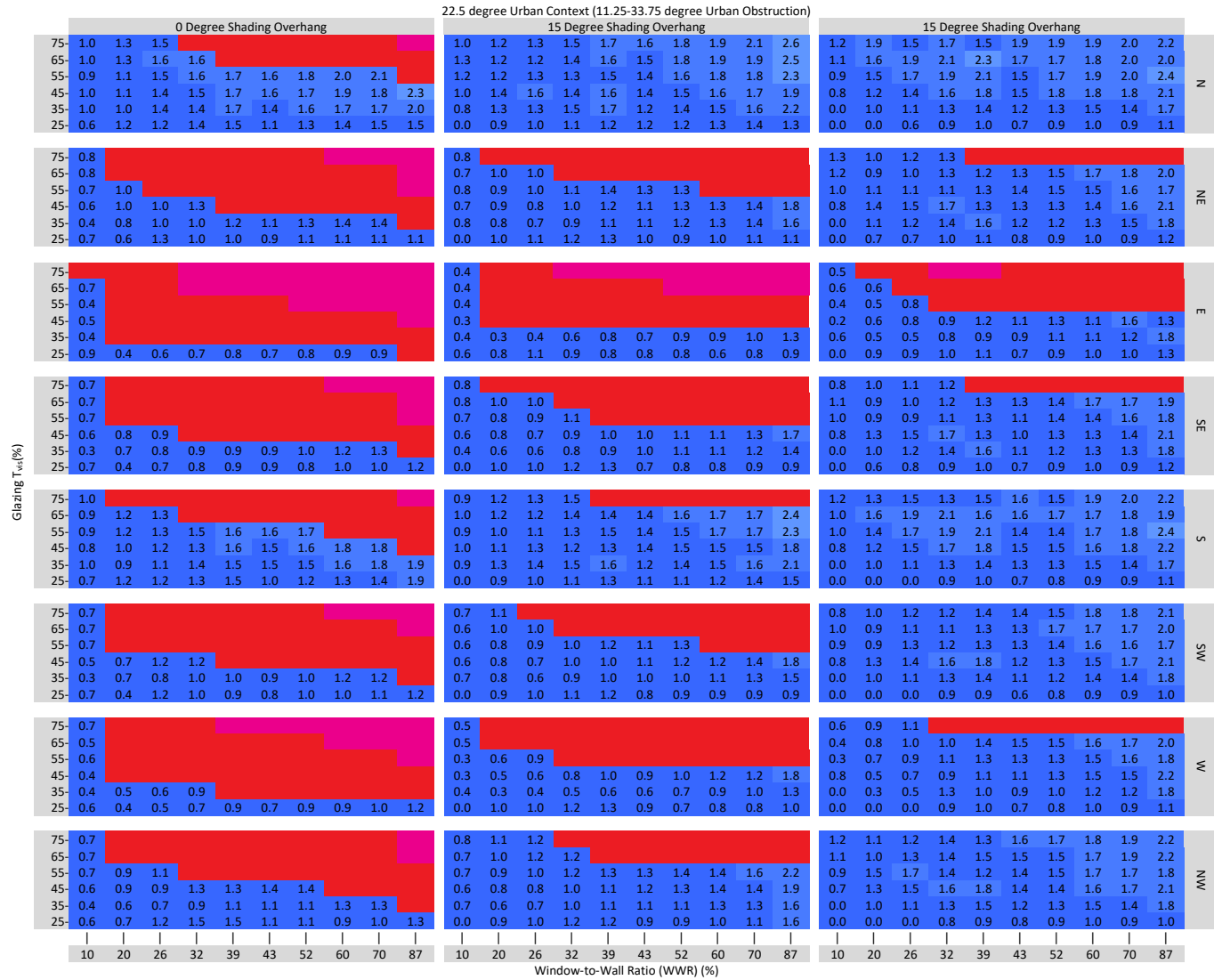

22.5 degree Urban Context for DA of 500 lux

Depth of DA_{500lux, 50%} daylight area minus UDLE_{3000lux, 10%} overlit area (commercial occupancy schedule)

- (0.00 to 1.50) m daylight depth
- (1.50 to 2.25) m daylight depth
- (2.25 to 3.00) m daylight depth
- (3.00 to 3.75) m daylight depth
- (3.75 to 4.75) m daylight depth
- (4.75 to 5.25) m daylight depth
- > 5.25 m daylight depth

- Potential Overlighting [1.3-2.0] m overlit depth
- Risk of Overlighting >=2.0 m overlit depth

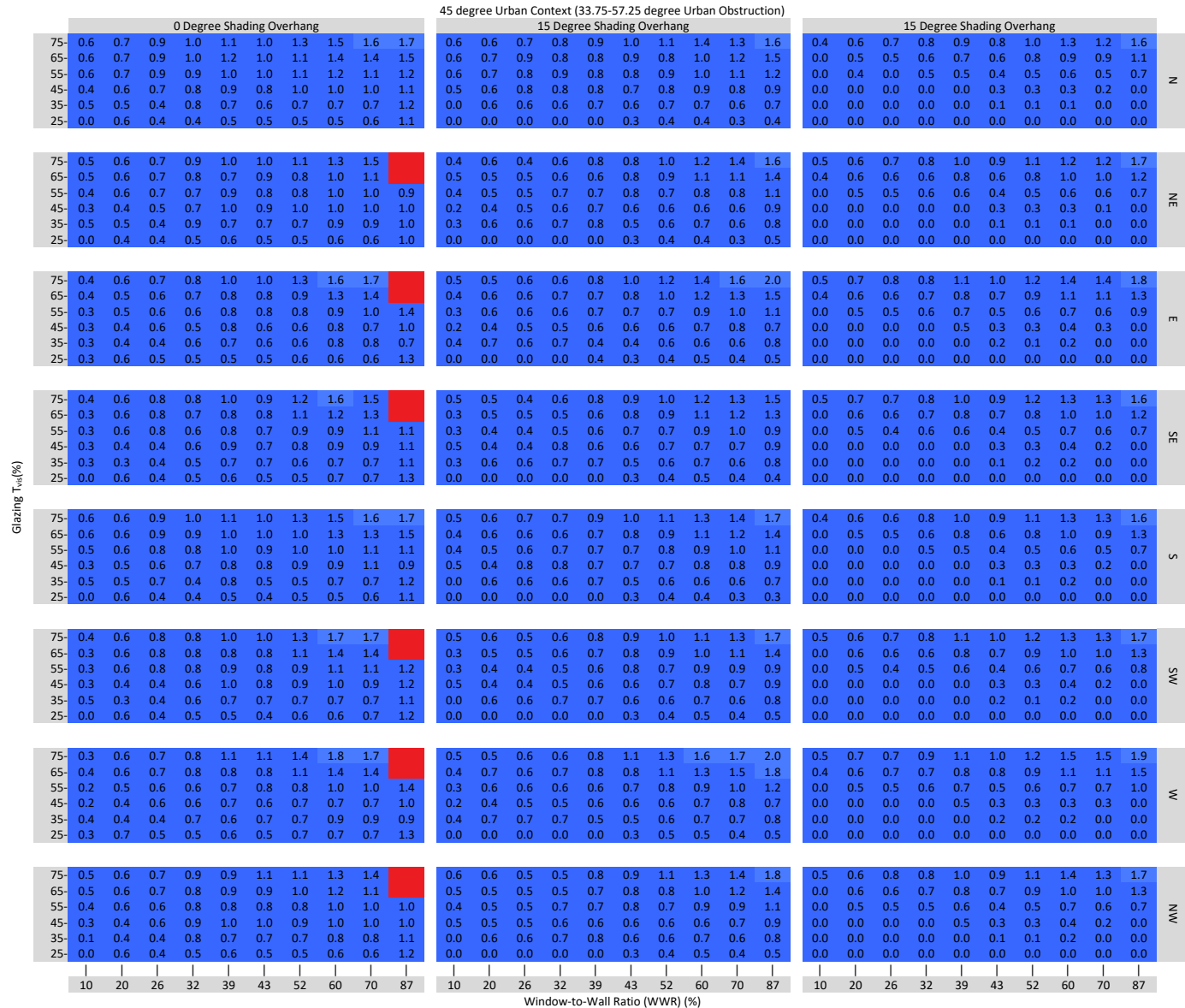

45 degree Urban Context for DA of 500 lux

Depth of DA_{500lux, 50%} daylit area minus UDLE_{3000lux, 10%} overlit area (commercial occupancy schedule)

- (0.00 to 1.50) m daylight depth
- (1.50 to 2.25) m daylight depth
- (2.25 to 3.00) m daylight depth
- (3.00 to 3.75) m daylight depth
- (3.75 to 4.75) m daylight depth
- (4.75 to 5.25) m daylight depth
- > 5.25 m daylight depth

- Potential Overlighting [1.3-2.0] m overlit depth
- Risk of Overlighting ≥ 2.0 m overlit depth

Direction

Annex C: Energy Modeling Methodology and Requirements

General

The energy modeling for evaluating the energy performance of a building shall be carried out in a prescribed manner to quantify the potential savings based on energy efficiency measures and improvements that reduce cooling load requirement over the Reference Model. The energy savings shall be measured by comparing the annual energy consumption of the Proposed Model (designed building) against the Reference Model (baseline building).

Simulation Software

The simulation software used for energy modeling shall meet the following criteria:

- It must have the capability to model the thermal performance of buildings in a multi zone format and calculate the building's total energy consumption over a continuous 12-months period.
- It must be tested by a recognised institution in accordance with *ANSI/ASHRAE Standard 140 – Standard Method of Test for the Evaluation of Building Energy Analysis Computer Programs* (or other equivalent standards).

Reference Model

(i) Baseline Standards

The simulation model for calculating the baseline building performance (known as Reference Model) shall be developed in accordance with the requirements in the following table on Baseline Standards. The requirements are applicable to all buildings, including building served by new/ existing DCS plants.

S/N	Component	Baseline Standard	Minimum Requirement												
1	Building Description														
1.1	Building Envelope Design	<p>BCA Approved Document Code on Envelope Thermal Performance for buildings</p> <p>SS 212 : 2007 – Specification for Aluminium Alloy Windows</p>	<p>(a) ETTV shall not exceed 50 W/m²</p> <p>(b) For roof with skylight, RTTV shall not exceed 50 W/m²</p> <p>For roof without skylight, the average U value of the gross area of the roof shall not exceed the limits below:</p> <table border="1"> <thead> <tr> <th>Weight Group</th> <th>Weight range (kg/m²)</th> <th>Maximum Thermal Transmittance (W/m²k)</th> </tr> </thead> <tbody> <tr> <td>Light</td> <td>Under 50</td> <td>0.5</td> </tr> <tr> <td>Medium</td> <td>50 to 230</td> <td>0.8</td> </tr> <tr> <td>Heavy</td> <td>Over 230</td> <td>1.2</td> </tr> </tbody> </table> <p>(c) All windows on the building envelope shall not exceed the air leakage rates specified in SS 212 : 2007.</p> <p>(d) Where the door opening of any commercial unit is located along the perimeter of the building envelope, that unit shall:</p> <ol style="list-style-type: none"> Be completely separated from the other parts of the building 	Weight Group	Weight range (kg/m ²)	Maximum Thermal Transmittance (W/m ² k)	Light	Under 50	0.5	Medium	50 to 230	0.8	Heavy	Over 230	1.2
Weight Group	Weight range (kg/m ²)	Maximum Thermal Transmittance (W/m ² k)													
Light	Under 50	0.5													
Medium	50 to 230	0.8													
Heavy	Over 230	1.2													

S/N	Component	Baseline Standard	Minimum Requirement
			(ii) Have its air-conditioning system separated from and independent of the central system.
1.2	Building Shape, Size and Configuration		Reference Model to be the same as Proposed Model
1.3	Building Zoning & Thermal Block		Reference Model to be the same as Proposed Model. Zoning of air-conditioned and non-air conditioned areas shall be modelled based on the approved building plan except for floor areas that conform to the provisions for <i>Passive Design Features</i> under Para 3.9 to reduce air-conditioned spaces. Where ACMV zones are defined on the ACMV design drawings, each ACMV zone shall be modelled as a separate thermal block.
2	System Description		
2.1	Air-conditioning System Types	<p>SS 530 : 2014 – Code of Practice for Energy efficiency Standard for Building Services and Equipment</p> <p>ASHRAE 90.1: 2013 – Energy Standard for Buildings Except Low-Rise Residential Buildings</p>	<p>(a) Based on the peak building cooling load, the reference system shall be as follows:</p> <ul style="list-style-type: none"> (i) Peak building cooling load \geq 500RT: Centrifugal chiller. <ul style="list-style-type: none"> - Peak cooling load \leq 800 RT: 1 number of centrifugal chiller - Peak cooling load $>$ 800 RT: N numbers of centrifugal chillers equally sized with each chiller \leq 800 RT (ii) Peak building cooling load $<$ 500RT and air-conditioned area \geq 5,000m²: Screw chiller <ul style="list-style-type: none"> - Peak cooling load \leq 300 RT: 1 number of screw chiller - Peak cooling load $>$ 300 RT: 2 numbers of screw chillers sized equally sized with each chiller \leq 300 RT (iii) Peak building cooling load $<$ 500RT and air-conditioned area $<$ 5,000m²: The reference system shall be of the same type as the proposed system. (iv) For VRF systems, the baseline of constant COP of 3.28, 3.22 and 2.93 shall be adopted, with reference to SS 530 : 2014, Table 1B. <p>(b) Additional chiller or other air conditioning configuration may be considered if the reference chiller(s) operate at less than 50% of its capacity for more than 20% of the time.</p> <p>(c) For buildings with chilled water supplied/ to be supplied by a District Cooling System (DCS) company:</p> <ul style="list-style-type: none"> (i) Path A: The above item (a) and (b) are applicable to building with chilled water supplied by DCS company under Path A. All ACMV components dedicated to the DCS plant and building designed shall be included and considered. The energy efficiency and chilled water system of the Proposed Model shall be that of the DCS plant. The baseline efficiency will be 0.80kW/ton (with reference to DCS Plant Boundary stated in P.4 Air Conditioning Total System and Component Efficiency). (ii) Path B: The energy consumption contribution from the DCS plant may be excluded from the energy modeling provided the two criteria as follows are complied with:

S/N	Component	Baseline Standard	Minimum Requirement																				
			<table border="1"> <thead> <tr> <th>Level of Green Mark Award</th> <th>Cooling Load Savings</th> <th>Energy Consumption Savings (exclude DCS plant)</th> </tr> </thead> <tbody> <tr> <td>Gold^{PLUS}</td> <td>10%</td> <td>27%</td> </tr> <tr> <td>Platinum</td> <td>15%</td> <td>33%</td> </tr> </tbody> </table> <p>Paths A and B shall be as per defined in the Technical Guide and <i>Requirements for P.4 Air Conditioning Total System and Component Efficiency</i>.</p>	Level of Green Mark Award	Cooling Load Savings	Energy Consumption Savings (exclude DCS plant)	Gold ^{PLUS}	10%	27%	Platinum	15%	33%											
Level of Green Mark Award	Cooling Load Savings	Energy Consumption Savings (exclude DCS plant)																					
Gold ^{PLUS}	10%	27%																					
Platinum	15%	33%																					
2.2	Chiller Efficiency	SS 530 : 2014	<p>Minimum energy efficiency standard stated in SS 530 : 2014. Please refer below for the default chiller efficiency curve.</p> <p>For District Cooling System, please refer to 2.1(c).</p>																				
2.3	Air-Conditioning Hydronic Systems	<p>SS 553 : 2015 -</p> <p><i>Code of Practice for Air-conditioning and Mechanical Ventilation in Buildings</i></p> <p><i>California Energy Commission Non-Residential Alternative Calculation Method Reference Manual 2013 Appendix 5.7</i></p>	<p>(a) Pumping system design criteria</p> <p>(b) For air-conditioning hydronic systems having a total pump system power exceeding 7.5 kW, the pump power limitation for chilled water systems shall be 349 kW/m³/s. The pump power limitation for condensing water systems is 301 kW/m³/s.</p> <p>(ii) For motors > 3.7 kW: The chilled water pump shall have VSD and the motor shall have controls and/ or devices (such as variable speed control) that will result in pump motor demand of no more than 30% of design wattage at 50% of design water flow.</p> <p>(iii) For motors ≤ 3.7 kW: The chilled water pump shall be the equivalent of a constant speed pump if motor is less than 3.7 kW.</p> <p>(iv) Condenser water pump shall be the equivalent of a constant speed pump.</p> <p>The above item (i) to (iv) are applicable to buildings with chilled water supplied by DCS companies. For Path B, only the customer building pumps shall be considered.</p> <p>(c) Calculation for part load performance of chilled water pump with VSD and the minimum operating load shall be capped at 50% (25 Hz) of the equipment capacity.</p> <p>Pump power ratio</p> $= 0.0205x + 0.4101x^2 + 0.5753x^3$ <p>where x is the part load ratio</p> <p>Values in table below are for reference only (projects are advised to use actual value and formula for computation)</p> <table border="1"> <thead> <tr> <th>x</th> <th>0.2</th> <th>0.3</th> <th>0.4</th> <th>0.5</th> <th>0.6</th> <th>0.7</th> <th>0.8</th> <th>0.9</th> <th>1</th> </tr> </thead> <tbody> <tr> <td>Pump ratio</td> <td>0.025</td> <td>0.059</td> <td>0.111</td> <td>0.185</td> <td>0.284</td> <td>0.413</td> <td>0.573</td> <td>0.770</td> <td>1.006</td> </tr> </tbody> </table> <p><i>Project team can propose other equivalent methodology but affinity law is not recommended as it does not take into account of loss in actual operating conditions.</i></p>	x	0.2	0.3	0.4	0.5	0.6	0.7	0.8	0.9	1	Pump ratio	0.025	0.059	0.111	0.185	0.284	0.413	0.573	0.770	1.006
x	0.2	0.3	0.4	0.5	0.6	0.7	0.8	0.9	1														
Pump ratio	0.025	0.059	0.111	0.185	0.284	0.413	0.573	0.770	1.006														

S/N	Component	Baseline Standard	Minimum Requirement																				
2.4	Cooling Tower	<p>SS 530: 2014</p> <p>California Energy Commission Non-Residential Alternative Calculation Method Reference Manual 2013 Appendix 5.7</p>	<p>Performance requirement for heat rejection equipment:</p> <p>a) Propeller or axial fan cooling towers: Cooling tower performance shall not be less than 3.23 L/s/kW.</p> <p>b) Centrifugal fan cooling towers: Cooling tower performance shall not be less than 1.7 L/s/kW.</p> <p>c) Calculation for part load performance of Cooling tower with VSD and the minimum operating load shall be capped at 50% (25 Hz) of the equipment capacity.</p> <p>Cooling tower fan power ratio = $0.331629 - 0.885676 x + 0.605565 x^2 + 0.948482 x^3$</p> <p>where x is the part load ratio</p> <p>Values in table below are for reference only (projects are advised to use actual value and formula for computation)</p> <table border="1"> <thead> <tr> <th>x</th> <th>0.2</th> <th>0.3</th> <th>0.4</th> <th>0.5</th> <th>0.6</th> <th>0.7</th> <th>0.8</th> <th>0.9</th> <th>1</th> </tr> </thead> <tbody> <tr> <td>CT ratio</td> <td>0.186</td> <td>0.146</td> <td>0.135</td> <td>0.159</td> <td>0.223</td> <td>0.334</td> <td>0.496</td> <td>0.716</td> <td>1.000</td> </tr> </tbody> </table> <p>Project team can propose other equivalent methodology but affinity law is not recommended as it does not take into account of loss in actual operating conditions.</p>	x	0.2	0.3	0.4	0.5	0.6	0.7	0.8	0.9	1	CT ratio	0.186	0.146	0.135	0.159	0.223	0.334	0.496	0.716	1.000
x	0.2	0.3	0.4	0.5	0.6	0.7	0.8	0.9	1														
CT ratio	0.186	0.146	0.135	0.159	0.223	0.334	0.496	0.716	1.000														
2.5	Air Conditioning Fan Systems	<p>SS 553 : 2015</p> <p>ASHRAE 90.1: 2013</p> <p>Non-domestic Building Services Compliance Guide 2013 Edition</p>	<p>The ratio of fan system power to the supply fan air flow rate (main fan) of each air-conditioning system at design conditions shall not exceed the allowable fan system power.</p> <p><u>Airflow Rate for Reference Model</u></p> <p>(a) The airflow rate for the Reference Model shall be based on the auto-sizing function of the energy modeling software used.</p> <p>(b) The Reference Model for spaces served by fan coil units (FCUs) shall be of constant flow system, and the airflow rate shall be auto-sized by the energy modeling software. For hotel guest room FCUs where the airflow rate simulated is less than that of the smallest FCU available in the market, the airflow rate of the proposed FCU can be adopted for the Reference Model.</p> <p><u>Fan System Design Criteria</u></p> <p>(c) For fan systems with a motor nameplate power ≥ 4 kW, the fan power limitation in air-conditioning system (the allowable fan system input power) shall be as follows:</p> <p>(i) Constant volume shall not exceed 1.5 kW/m³/s (or 0.42 W/CMH + A) of supply air. Reference control strategy for CAV system shall be constant speed.</p> <p>(ii) Variable volume shall not exceed 2.1 kW/m³/s (or 0.58 W/CMH + A) of supply air.</p> <p>Note: Fan power limitation pressure drop adjustment is not applicable for the following devices:</p> <ul style="list-style-type: none"> - Return and/or exhaust air systems - Return and/or exhaust airflow control devices - Exhaust filters or other exhaust treatment - Particulate Filtration Credit: MERV 9 – 14 <p>Fan power limitation pressure drop adjustment can be considered for activities where higher fan power is expected to overcome the high static pressure of the</p>																				

S/N	Component	Baseline Standard	Minimum Requirement																													
			<p><i>specialized hardware such as kitchen exhaust, heap filter or high pressure exhaust system used in clean room, laboratories and hospitals. There is no exception to the reference for cases when the proposed fan power exceeds the reference power limitation in Table 2b of SS 553 : 2015</i></p> <p>(d) For fan system having a motor nameplate power < 4 kW, the allowable fan system input power shall be ≤ 0.6 kW/m³/s (0.17 W/CMH) of supply air. For cases where the proposed fan power exceeds the reference power limitation, the energy consumption of the proposed fan can be applied to the Reference Model.</p> <p>(e) For computation of fan power, 5% driver loss needs to be accounted for the use of VSD. Project team can use lower value if they can substantiate VSD loss with documentation.</p> <p><u>Part load fan power limitation</u></p> <p>(f) The reference control strategy for VAV system shall come with VSD without exemption, applicable to all fans including small fan motors ≤ 7.4 kW.</p> <p>(g) Individual VAV fans with motors of ≥ 7.4 kW shall meet one of the following requirements:</p> <ul style="list-style-type: none"> - Be driven by an electrical variable speed drive. - Have other controls and devices for the fan that will result in fan motor demand of less than 30% of design wattage at 50% of design air volume when static pressure set point equals one-third of the total design static pressure based on manufacturer’s certified fan data. - Calculation for part load performance of VAV fan with VSD and the minimum operating load shall be capped at 50% (25 Hz) of the equipment capacity. The part load fan power calculator may be referenced from ASHRAE 90.1, Table G3.1.3.15, <i>Part-Load Performance for VAV Fan Systems, Method 2 – Part-Load Fan Power Equation</i> for part load fan power calculation. <p>Fraction of full-load fan power = 0.0013 + 0.1470x + 0.9506x² - 0.0998x³ <i>where x is the part load ratio (Ratio of current L/s against design L/s)</i></p> <p>Values in table below are for reference only (projects are advised to use actual value and formula for computation)</p> <table border="1" data-bbox="625 1417 1388 1501"> <thead> <tr> <th>x</th> <th>0.2</th> <th>0.3</th> <th>0.4</th> <th>0.5</th> <th>0.6</th> <th>0.7</th> <th>0.8</th> <th>0.9</th> <th>1</th> </tr> </thead> <tbody> <tr> <td>Fan ratio</td> <td>0.068</td> <td>0.128</td> <td>0.206</td> <td>0.300</td> <td>0.410</td> <td>0.536</td> <td>0.676</td> <td>0.831</td> <td>1.000</td> </tr> </tbody> </table> <p>For laboratories, ACH baseline will reference to existing laboratory with similar function and there should be setback ACH during non-occupancy. Where information is not readily available, the following baseline can be considered after discussion with assessors. Projects should design for minimum flowrate to reduce energy consumption within safety limit.</p> <table border="1" data-bbox="625 1774 1388 1942"> <thead> <tr> <th>Laboratories</th> <th>ACH for unoccupied hours</th> <th>ACH for occupied hours</th> </tr> </thead> <tbody> <tr> <td>BSL1</td> <td>3</td> <td>4</td> </tr> <tr> <td>BSL2 & 3 (Sprinkled)</td> <td>4</td> <td>8</td> </tr> </tbody> </table>	x	0.2	0.3	0.4	0.5	0.6	0.7	0.8	0.9	1	Fan ratio	0.068	0.128	0.206	0.300	0.410	0.536	0.676	0.831	1.000	Laboratories	ACH for unoccupied hours	ACH for occupied hours	BSL1	3	4	BSL2 & 3 (Sprinkled)	4	8
x	0.2	0.3	0.4	0.5	0.6	0.7	0.8	0.9	1																							
Fan ratio	0.068	0.128	0.206	0.300	0.410	0.536	0.676	0.831	1.000																							
Laboratories	ACH for unoccupied hours	ACH for occupied hours																														
BSL1	3	4																														
BSL2 & 3 (Sprinkled)	4	8																														

S/N	Component	Baseline Standard	Minimum Requirement						
			<table border="1"> <tr> <td>BSL2 & 3 (Non-Sprinkled)</td> <td>6</td> <td>12</td> </tr> <tr> <td>CDSL 1, 2, 3</td> <td>Minimum opening for fume hood(s)</td> <td>Maintain minimum 0.5m/s airflow for fume hood(s) at working position. Reasonable diversity to be considered.</td> </tr> </table> <p>*ACH baseline for BSL4 / CDSL4 to be discussed with assessor(s) on case-by-case basis if baseline for BSL3/CDSL3 are not suitable.</p>	BSL2 & 3 (Non-Sprinkled)	6	12	CDSL 1, 2, 3	Minimum opening for fume hood(s)	Maintain minimum 0.5m/s airflow for fume hood(s) at working position. Reasonable diversity to be considered.
BSL2 & 3 (Non-Sprinkled)	6	12							
CDSL 1, 2, 3	Minimum opening for fume hood(s)	Maintain minimum 0.5m/s airflow for fume hood(s) at working position. Reasonable diversity to be considered.							
2.6	Mechanical Ventilation Fan Systems	<p>SS 553 : 2015</p> <p>ASHRAE 90.1: 2013</p> <p>Non-domestic Building Services Compliance Guide 2013 Edition</p>	<p>The ratio of fan system power to the supply fan air flow rate (main fan) of each ventilation system at design conditions shall not exceed the allowable fan system power.</p> <p><u>Fan system design criteria</u></p> <p>(a) Mechanical ventilation systems having a total fan system power ≥ 4 kW shall refer to SS 553 : 2015, Table 8 – Fan Power Limitation in Mechanical Ventilation Systems.</p> <p>(a) Reference fan power limitation for mechanical ventilation system shall be constant volume type and the fan system input shall not exceed $0.3 \text{ W/CMH} + A$.</p> <p><i>Note: The fan power limitation pressure drop adjustment is not applicable for the following devices:</i></p> <ul style="list-style-type: none"> - Exhaust air systems - Exhaust airflow control devices - Exhaust filters <p><i>Exceptions can be considered for activities where higher fan power are expected to overcome the high static pressure of the specialized hardware such as kitchen exhaust, heap filter or high pressure exhaust system used in clean room, and hospital. There is no exception to the Reference Model for cases when proposed fan power exceeds the baseline power limitation.</i></p> <p>(b) For fan system with a motor nameplate power < 4 kW, the allowable fan system input power shall not exceed $0.6 \text{ kW/m}^3/\text{s}$ (or 0.17 W/CMH) of supply air. For cases where the proposed fan power exceeds the reference power limitation, the energy consumption of the proposed fan can be applied to the Reference Model.</p>						
2.7	Design Airflow Rates	ASHRAE 90.1:2013 Section G3.1.2.9.1	For systems serving laboratory spaces, use a supply-air-to-room-air temperature difference of 9°C or the required ventilation air or makeup air, whichever is greater.						
2.8	Exhaust Air	ASHRAE 90.1:2013 Section 6.5.7.2	Buildings with laboratory exhaust systems having a total exhaust rate greater than 2360 L/s should adopt at least one of the energy efficient features as stated in ASHRAE 90.1 Section 6.5.7.2.						

S/N	Component	Baseline Standard	Minimum Requirement
2.9	Lighting Systems	SS 530 : 2014 ASHRAE 90.1:2013	<p>(a) The maximum design lighting power (including ballast loss) for a building's interior lighting shall not exceed the sum of maximal power for various areas calculated in accordance with SS 530 : 2014, Table 7A- Maximum Building Interior Lighting Power Density for Compliance (Space-By Space Method). Particularly, the maximum design lighting power (including ballast loss) for laboratories shall be 16W/m². The allowable lighting power density stated in ASHRAE 90.1:2013 can be considered if the lighting power budget for the types of usage is not available in SS 530.</p> <p>(b) The allowable building exterior and outdoor (uncovered area) lighting power shall be the combined total of the sum of the general hardscape lighting allowance determined in according to SS 530, Table 7D and the sum of the additional lighting power allowance for specific applications determined in accordance with Table 7E. The maximal power density requirements specified in Table 7D are tradable but those specified in Table 7E are not, unless stated otherwise.</p>
2.10	Hot Water generation	SS 530 : 2014 SS 553 : 2015	<p>(a) For generation of hot water $\leq 60^{\circ}\text{C}$, the baseline shall be a heat pump with COP of 3.2.</p> <p>(b) Control of indoor thermal environment via reheat of the air shall not be allowed except for energy source from site-recovered energy (including condenser heat) or site-solar energy, referring to SS 553, Section 8.14. The baseline for this case will be heat pump with COP of 3.2.</p>
2.11	Energy Recovery Systems	SS 553 : 2015	<p>(a) Exhaust air of 2.5 m³/s or greater from conditioned space in a single location shall have energy recovery system with at least 60% recovery effectiveness. 60% recovery effectiveness shall mean a change of enthalpy of the outdoor air supply equal to 60% of the difference between the outdoor air and return air at design conditions when tested under AHRI standard 1060.</p> <p>(b) Control of indoor thermal environment by reheating the air shall not be allowed except for energy source from site-recovered energy (including condenser heat) or site-solar energy, refer to SS553, Section 8.14. The baseline for this case will be heat pump with COP of 3.2.</p>
3	Others		

S/N	Component	Baseline Standard	Minimum Requirement																								
3.1	Receptacle & Process loads	ASHRAE 2013 ASHRAE Fundamentals Handbook (SI)	<p>In general, the receptacle value for both the Reference Model and proposed design shall be the same. Some default figures are as mentioned:</p> <table border="1"> <thead> <tr> <th>Receptacle Loads</th> <th>Standard</th> <th>Nominal Values</th> </tr> </thead> <tbody> <tr> <td>a. Computer intensive offices</td> <td></td> <td>22.0 W/m²</td> </tr> <tr> <td>b. General office areas</td> <td></td> <td>16.0 W/m²</td> </tr> <tr> <td>c. Large conference areas</td> <td></td> <td>11 W/m²</td> </tr> <tr> <td>d. Server/ Computer rooms Data Centre</td> <td>Source: ASHRAE 90.1.2013</td> <td>540.0 W/m²</td> </tr> <tr> <td>e. Server Room</td> <td></td> <td>270 W/m²</td> </tr> <tr> <td>f. Schools (Tertiary/IHLs)</td> <td></td> <td>8 W/m²</td> </tr> <tr> <td>g. Schools (Primary/Secondary)</td> <td></td> <td>5 W/m²</td> </tr> </tbody> </table> <p>Receptacle load to be capped at 25% of baseline total energy building's energy consumption if it exceeds that value.</p> <p><u>Office Receptacle Loads</u></p> <p>Energy savings is allowed in the form of a lower W/m² for the proposed design (as compared to 16 W/m² for the Reference Model) if the project can commit to deliver lower receptacle density at verification. The project team must provide a green lease, dedicated energy meters and tenant engagement programme as evidences for Green Mark assessment.</p> <p><u>Data Centres</u></p> <p>Energy consumed by data centres must be included as receptacle loads in the model. The scope and the calculation methodology must take reference from the <i>BCA-IDA Green Mark for New Data Centre Criteria</i>. The PUE of data centres must be ≤ 2. The building owner is encouraged to apply for the <i>BCA-IDA Green Mark for New Data Centre scheme</i> if the share of the energy consumed by the data centre is substantial compared to the building's total energy consumption.</p> <p><u>Laboratories</u></p> <p>Project could take reference from the receptacle load values stated in the <i>ASHRAE Fundamentals Handbook (SI)</i> or other international recognised guides with diversity and should consider existing measured data.</p> <p><u>Schools</u></p> <p>Energy savings, for above listed area, are allowed in the form of a lower W/m² for the proposed design if the project can commit to deliver lower receptacle density at verification. The project must be able to effectively measure the areas' energy consumption as evidences for Green Mark assessment</p>	Receptacle Loads	Standard	Nominal Values	a. Computer intensive offices		22.0 W/m ²	b. General office areas		16.0 W/m ²	c. Large conference areas		11 W/m ²	d. Server/ Computer rooms Data Centre	Source: ASHRAE 90.1.2013	540.0 W/m ²	e. Server Room		270 W/m ²	f. Schools (Tertiary/IHLs)		8 W/m ²	g. Schools (Primary/Secondary)		5 W/m ²
Receptacle Loads	Standard	Nominal Values																									
a. Computer intensive offices		22.0 W/m ²																									
b. General office areas		16.0 W/m ²																									
c. Large conference areas		11 W/m ²																									
d. Server/ Computer rooms Data Centre	Source: ASHRAE 90.1.2013	540.0 W/m ²																									
e. Server Room		270 W/m ²																									
f. Schools (Tertiary/IHLs)		8 W/m ²																									
g. Schools (Primary/Secondary)		5 W/m ²																									
3.2	Occupancy Rates		Same as proposed design																								
3.3	Operation Schedules		Same as proposed design																								
3.4	Indoor Thermal Comfort Conditions	SS554 :2015 – Code of Practice for Indoor Air Quality for Air-	Same as proposed design																								

S/N	Component	Baseline Standard	Minimum Requirement
		<i>conditioned Buildings</i>	
3.5	Minimum Ventilation Rates	SS 553 : 2015 NFPA 45 EPA	<p>Same as proposed design except for laboratories.</p> <p>For laboratories, baseline air change rate would be:</p> <ul style="list-style-type: none"> • 8 ACH (Occupied) • 4 ACH (Non-occupied) <p>The project team can propose values for specific usages based on international/ Singapore recognised guidelines.</p>
3.6	Heat Exchanger		Same as proposed design
3.7	Lift and Escalator without Regenerative Drive		<p>Same as proposed design</p> <p>Both the reference and proposed design baseline should incorporate A/C VVVF features.</p>
3.8	Modeling Limitation or Simulation Program		Same as proposed design
3.9	Passive Design Features		<p>For projects that demonstrate considerable efforts to reduce air-conditioning energy consumption, a cap of 3% of additional energy savings from passive design features over its Reference Model can be considered.</p> <p>For savings to be justified, design strategies that enhance the ventilation and thermal comfort of the designated non air-conditioned spaces must be demonstrated. A written justification detailing the design strategies used and evidences accompanied with simulation and/or calculation of the energy saving estimate would be required for evaluation.</p> <p><u>Examples</u></p> <ul style="list-style-type: none"> • Circulation spaces such as atria, can be considered if these spaces are largely designed to be non-air-conditioned and sizeable. This is not applicable to areas that would normally be non-air-conditioned, such as warehouses, school classrooms and pantries. • The introduction of air well or slopes to convert a mechanical ventilated car park to a code compliant natural ventilated car park is also acceptable. However, open air naturally ventilated carparks cannot be considered for energy savings.
4.0	Renewable Energy		<p>Energy generated from renewable sources, such as solar photovoltaic (PV) systems, could be used to offset the 25% and 30% energy savings requirement for Gold^{PLUS} and Platinum projects respectively, up to a maximum of 3% energy savings against the annual energy consumption from the Reference Model.</p> <p>For example, if a project has annual energy consumption of 100 MWh simulated from the Reference Model and 72 MWh from the Proposed Model, the project can attain 28% energy savings. However, if it has solar PV installed to produce 2 MWh annually, it could offset a further 2% of the energy savings. This brings its total energy savings to 30%.</p>

S/N	Component	Baseline Standard	Minimum Requirement
<p><i>Note:</i> Where there is no baseline standard for certain energy related features such as chilled beams, underfloor air distribution systems, receptacle loads, lifts and escalators, hot water systems, reference can be made to ASHRAE 90.1:2013 Appendix G. For buildings with special requirements where there is no reference based on ASHRAE 90.1:2013 Appendix G, the baseline set for similar building type completed after 2005 can be considered. Detailed calculations must be provided to justify the savings in energy consumption from the use of salient energy efficient features /equipment. Where justification cannot be provided, the same input parameters for good design practice shall apply to both the Reference and Proposed Model.</p>			

(ii) Default Chiller Efficiency Curve

The default Chiller Curve and Chiller Configuration, references to SS 530 : 2014, AHRI 551/591, Path A, Full Load Conditions. The standard rating conditions are based on chilled water **supply** temperature at 7.0°C, chilled water **return** temperature at 12.0°C, condenser water entering temperature at 30.0°C and condenser water leaving temperature at 35.0°C. The default part load performance curves below are provided in DOE 2.2 and IESVE software 2014 which are compliant with California's TM24 requirement:

Equipment Type	Size Category	COP									
		10%	20%	30%	40%	50%	60%	70%	80%	90%	100%
Rotary Screw and Scroll	< 263kW	3.125	3.581	3.809	3.970	4.105	4.228	4.345	4.461	4.576	4.694
	≥ 264 kW and < 528 kW	3.255	3.730	3.967	4.135	4.276	4.403	4.526	4.646	4.767	4.889
	≥ 528 kW and < 1055 kW	3.551	4.069	4.328	4.511	4.665	4.804	4.938	5.069	5.200	5.334
	≥ 1,055 kW and < 2110 kW	3.842	4.403	4.683	4.881	5.047	5.198	5.342	5.484	5.626	5.771
	≥ 2,110 kW	4.185	4.796	5.100	5.317	5.497	5.662	5.819	5.974	6.129	6.286
Centrifugal	< 1,055 kW	1.676	2.914	3.821	4.478	4.949	5.279	5.504	5.648	5.732	5.771
	≥ 1,055kW and < 1,407 kW	1.826	3.174	4.162	4.878	5.391	5.750	5.995	6.152	6.244	6.286
	≥ 1,407kW	1.826	3.174	4.162	4.878	5.391	5.750	5.995	6.152	6.244	6.286

Energy Modeling Methodology

The simulation model of the Proposed Model, as well as the Reference Model shall be:

- (a) Developed in accordance with the design parameters of the building. This includes:
 - Building design layout in terms of shape, size and orientation
 - Materials for walls, windows, roofs, floors, doors and permanent shading devices, internal partitions between conditioned and non-conditioned spaces
 - Internal loads such as levels and schedules for occupancy, lighting systems, equipment, appliances and machinery within the building
 - ACMV equipment, controls and other associated components selected for use in the building

- (b) Calculated using the same:
 - Software
 - Weather data: Appropriate up-to-date weather set should be used for energy modeling such as ASHRAE's International Weather for Energy Calculation data for Singapore.

- Operating schedules
 - Occupancy rates
 - Building design in terms of shape, size and orientation
 - Receptacle loads (exception for office, see 3.7 under Table 1 for requirements)
 - Indoor environmental conditions in terms of thermal comfort level: If a different condition such as higher space temperature is used in the Proposed Model, there must be evidence to demonstrate that the overall thermal comfort level is not lower than that of the Reference Model.
 - Internal illuminance levels (lux) for space lightings
- (c) Based on the overall energy consumption computed over a period of 1 year using the building envelope and all energy consuming equipment that are selected during the design stage. This includes energy consumed by chillers, air handling systems, plant equipment (e.g. water pumps, cooling towers, tube cleaning devices, chillers, etc.), and non-ACMV systems such as lighting, lifts, escalators, ceiling fans and receptacle loads from equipment (e.g. photo-copiers, printers, fax machines, computers, laptops, fridges, projectors, audio-cum video systems, water heaters, dryers, washers, etc.).

The basis for deriving the overall energy consumption and potential energy savings must be made clear and justifiable for consideration. Notwithstanding this, the potential energy savings for the following systems/devices shall be capped as follows:

List of Systems/Devices	Cap on Energy Savings Devices
Escalator	30%
Lift with regenerative features	18%
CO Sensors	15%
Occupancy sensors	15%
Photo sensors	15%
Renewable energy (e.g. solar energy)	3%

The improved performance of the proposed building design can then be obtained by making comparison of the overall energy consumption of the Reference Model against the Proposed Model.

Calculation of Energy Efficiency Index (EEI) and Energy Use Intensity (EUI)

The normalised EEI based on the proposed model result shall be computed using the formula:

$$EEI_{Normalised,model} = \frac{TBEC - DCEC - CPEC}{GFA - DCA} \times \frac{NF}{OH}$$

The EEI shall be computed as follows:

$$EEI_{model} = \frac{TBEC - DCEC - CPEC}{GFA - DCA}$$

The building overall EUI, excluding car park shall be calculated as follows:

$$EUI_{model} = \frac{TBEC - CPEC}{GFA}$$

The car park EUI shall be calculated as follows

$$EUI_{Carpark,model} = \frac{CPEC}{CPFA}$$

TBEC: Total building energy consumption (kWh/year)

DCEC: Data centre energy consumption (kWh/year)

CPEC: Car park energy consumption (kWh/year)

CPFA: Total floor area for car park (m²)

DCA: Data centre areas (m²)

GFA: Gross floor area (m²)

OH: Weighted weekly operating hours (hours/week)

NF: Normalising factor based on typical weekly operating hours of the following building types:

Office: 55 hours/week

Retail: 84 hours/week

Hotel and Industrial: 168 hours/week

Institutions: 60 hours/week

Carpark: 168 hours/week

Documentation Requirements

(A) Design Stage

The name and company of the Energy Modeling consultant, details of software used and its limitations, building type and complexity shall be submitted to BCA. The *Energy Modeling Form for Green Mark Scheme (Finalisation of Building Design)* following shall be submitted, of which the template may be found at the following link:

[http://www.bca.gov.sg/GreenMark/others/Energy_Modelling_Form_Template_\(GM_NRB2015\).doc](http://www.bca.gov.sg/GreenMark/others/Energy_Modelling_Form_Template_(GM_NRB2015).doc)

The Qualified Person (QP) and the appropriate practitioners shall certify that the energy modeling for the building has been carried out in accordance with the requirements using the energy modeling methodology. The appropriate practitioner shall ensure that the assumptions and inputs used for energy modeling are bona fide. The energy modeling specialist shall certify and be responsible for the correctness of the modeling included proper usage of the relevant software.

The QP and the appropriate practitioners shall ensure the following documents and records are available as evidences to demonstrate compliance with the energy modeling framework and validation of the potential energy savings during final assessment. They are:

- (a) Certification showing that the simulation software is tested and meet the criteria in accordance with the ANSI/ASHRAE Standard 140
- (b) Detailed drawings and other necessary information of proposed design
- (c) Detailed system design calculation
- (d) Summary of Space and Envelope Thermal Transfer Value (ETTV) of the Building Envelope as in *Energy Modeling Form for Green Mark Scheme (Finalisation of Building Design)*
- (e) List of data such as:
 - Space input data for all zones comprising detail information on construction materials and their properties designed for each individual zone. For example, room area, walls, windows, doors, floors, partitions, sensible and latent loads (lightings, occupancy rates, receptacles loads, outdoor ventilation rates, misc. loads etc.). Schedules for each individual operating zone (e.g. lighting, occupants, mechanical fans, AHUs, other mechanical and electrical equipment, etc.)
 - Executable input data files used in the generation of the energy estimates for the Proposed and Reference Models
 - Output data on the monthly energy consumption by mechanical and electrical system components (e.g. Air-conditioned systems, Lighting Systems, Receptacle Equipment, Lifts, Escalators etc.)

- One year simulated hourly cooling load data in the form of the Frequency vs Cooling Load (RT) plot, Cooling Load vs Time, A/C efficiency vs Time
 - Detailed computation of the ETTV for both Reference and Proposed Models
 - Comparison of Reference Model versus Proposed Model as in Form: Energy Modeling Form (Finalisation of Building Design)
 - Summary of Energy of End Use including Efficiency Indicators for both Reference and Proposed Models as in *Energy Modeling Form (Finalisation of Building Design)*
 - Summary printouts of energy modeling software for the Reference Model including summary of weather data results Monthly energy consumption of mechanical and electrical system components such as air-conditioned system, lighting systems, receptacle equipment's, lift and escalator etc.
 - Assumptions and limitations in modeling with rectifications
- (f) Executable file of the EM simulation for both the Proposed and Reference Models
- (g) Recommendations (if any)

(B) Verification Stage 2

For Gold^{PLUS} and Platinum projects, when the building starts to operate in a steady state, the developer shall within 2 years after TOP, commence to gather data on actual site operation for the next 12 months period. Appropriate and adequate power meters shall be installed to measure and record the breakdown on the energy consumption from the utilities bills. Sub-meters are required to capture the annual consumption of data centre and car park lighting and mechanical ventilation. Separate meters shall be provided during design stage to record the annual energy consumption generated by renewable energy e.g. solar photovoltaic (PV) and energy savings claimed by energy saving devices, e.g. escalators, lifts, CO sensors and occupancy sensors and photo sensors. Adequate meters shall be installed to data log and monitor and extract the necessary information, e.g. monthly and annual energy generated (kWh) from the Solar PV. Dedicated meters shall be installed to measure the operational energy consumption and intensities of receptacle load (W/m²) of office space to verify on the energy savings claimed in energy modeling. Using the data on actual site operation, a revised energy modeling shall be performed to compare the annual energy consumption of the Reference Model with the actual consumption of the building.

The project developer or building owner shall submit a Stage 2 Verification Audit Report of at least, but not be limited to, the following content:

- a) Form for *Energy Modeling Form for Green Mark Scheme (Validation After Project Completion)* - the template may be found at the following link:
[http://www.bca.gov.sg/GreenMark/others/Energy_Modelling_Form_Template_\(GM_NRB2015\).doc](http://www.bca.gov.sg/GreenMark/others/Energy_Modelling_Form_Template_(GM_NRB2015).doc)
- b) Electricity bills: Building landlord/ tenants/ DCS company bills for 12 months if applicable. Building cooling provision from DCS company (Path A and Path B) shall provide energy efficiency information (kW/RT) of the plant to facilitate the computation of EEI and EUI of the customer building. Monthly bills paid to DCS company shall be provided to facilitate EEI and EUI computation at verification stage.
- c) Energy Audit (GM NRB: 2015) Report (the template may be found the following link:
[http://www.bca.gov.sg/GreenMark/others/Energy_Audit_Report_\(GM_NRB2015\).doc](http://www.bca.gov.sg/GreenMark/others/Energy_Audit_Report_(GM_NRB2015).doc))

- d) As-built electrical single-line schematics drawings
- e) Description of deviations of the building operations to the Proposed Energy Model which was submitted for Green Mark Certification e.g. monthly building occupancy rate, receptacle loads, data centre addition etc.
- f) BMS data log for the individual energy end use as in the actual energy breakdown under the Form for Energy Modeling for Green Mark Scheme (Validation After Project Completion); kWh raw data in softcopy Microsoft Excel file format and categorized according to the meters as-built schematics design.
- g) Temporary logging of energy end use as in Form for Energy Modeling for Green Mark Scheme (Validation After Project Completion); kWh raw data in softcopy Microsoft Excel file format.
- h) Data Centre Monthly Energy Consumption - kWh raw data in softcopy (if applicable).
- i) BMS data log and monitoring of monthly and annual energy generated (kWh) from renewable energy
- j) For actual building operations, state:
 - (i) Operation hours for the spaces using the cooling load profiles
 - (ii) Operation of chiller plant
 - Operating hours
 - Installed capacity
 - Duty and standby
 - Latest 1- week building cooling load
 - Latest 1-week chiller plant efficiency profile
 - (iii) Operation hours of other air-con systems e.g. unitary system for after office hours cooling demand
 - Spaces with after office hours demand
 - (iv) Human load schedules
 - (v) Lighting schedules
- k) EEI and EUI Calculation
 - (i) The operational hours of the building and car park
 - (ii) Area of the car park
 - (iii) EUI information must tally with submission to BCA BESS system.
- l) For Reference Energy Model, state:
 - (i) Operation hours for the spaces (Must be similar to actual operation)
 - (ii) Operation of chiller plant
 - Capacity and configuration in simulation
 - Simulated 1- week building cooling load
 - Simulated 1-week chiller plant efficiency profile
 - (iii) Operation hours of other air-con systems e.g. unitary system for after office hours cooling demand (Must be similar to actual operation)
 - Spaces with after office hours demand
 - (iv) Human load schedules (Must be similar to actual operation)
 - (v) Simulation file in softcopy

A project will have deemed to have met the pre-requisite where the key energy consuming components are operating to their designed efficiencies. A calibrated reference model shall not be required except for circumstances including:

- (a) A significant discrepancy in comparison with the energy model results
- (b) Change of primary use
- (c) A change of functional area distribution
- (d) Changes in equipment specifications and performance
- (e) Changes in GFA
- (f) Change in ventilation modes

Guidance Notes

To assist in the generation of satisfactory results from the energy modeling simulation, the EM consultant should adhere to the following self-assessment checklist before the energy modeling assessment.

Checklist Item	Notes
A. Overview	<ol style="list-style-type: none"> 1) Verify if Energy Modeling is required. 2) Verify the key performance indicators (KPI) <ol style="list-style-type: none"> a. EEI b. W/m² c. kW/RT
B. Input Checks (for both proposed and reference model)	<ol style="list-style-type: none"> 1) General Setting <ol style="list-style-type: none"> a. Weather b. Elevation c. Orientation d. Area summary (discrepancies within 5%) 2) Façade <ol style="list-style-type: none"> a. Select at least 3 areas to verify façade selection b. Construction c. SC value of glass and U-Value of walls and windows. 3) Thermal Zoning 4) HVAC design <ol style="list-style-type: none"> a. Typical space W/m² and whole building W/m² b. Cooling load profile c. Cooling system <ul style="list-style-type: none"> • Compressor (e.g. chiller if applicable) • Condenser (e.g. cooling tower if applicable) • Pumps (if applicable) • Overall and individual efficiency (kW/RT) d. Air distribution (baseline - provide oversizing factor) <ul style="list-style-type: none"> • Individual W/CMH • Typical CMH/m² and whole building CMH/m² • Overall air distribution kW/RT e. Overall – Provide unmet hours (Should not exceed 300 unmet hours) 5) Lighting 6) Receptacle load 7) MV fans

Checklist Item	Notes
	8) Schedule and diversity (including non-A/C areas like car park) 9) Energy saving items, eg heat recovery 10) Non-modelled items by alternative calculation
C. Output checks	1) Indoor thermal parameters for three typical indoor spaces 2) Daily, weekly, and monthly building cooling load 3) Energy breakdown proportion
D. Consistency checks	1) Proposed model and reference model consistency 2) Input data and output data consistency 3) Assumption verification 4) Exception calculation method