



Don't just build it...

Protect it!



GRACE

Weather **Protection** Systems

Table of Contents



Roofing Underlayments	3	Product Data Sheets	33
Product Selector Guide	4	Grace Ice & Water Shield®	35
Grace Ice & Water Shield®	5	Grace Ice & Water Shield® HT	39
Grace Ice & Water Shield® HT	7	Grace Ultra™	43
Grace Ultra™	9	Grace Select™	47
Grace Select™	11	Grace Tri-Flex®	51
Grace Tri-Flex®	13	Grace Syn 15™	55
Grace Syn 15™	15	Grace Roof Detail Membrane	59
Weather Resistive Barriers & Flashings	17	Vycor® enV-S™	63
Vycor® enV-S™	19	Vycor enV®	67
Vycor enV®	21	Vycor® Plus	71
Vycor® Plus	23	Vycor® PRO	75
Vycor® PRO	25	Vycor® V40	79
Basement Waterproofing and Vapor Barriers	27	Vycor® Aluminum Flashing	81
Grace Bituthene®	29	Grace Bituthene®	85
Grace Florprufe®	31	Grace Florprufe®	91
		Perm-A-Barrier® Primer Plus	93
		Perm-A-Barrier® WB Primer	95



Roofing Underlayments

.....

- Product Selector Guide
- Grace Ice & Water Shield®
- Grace Ice & Water Shield® HT
- Grace Ultra™
- Grace Select™
- Grace Tri-Flex®
- Grace Syn 15™

Roofing Underlayments | PRODUCT SELECTION GUIDE

Self-Adhered Smooth Surface Underlayments				Mechanically Attached Synthetic Underlayments	
Grace Ice & Water Shield®	Grace Ice & Water Shield® HT	Grace Ultra™	Grace Select™	Grace SYN 15™	Grace Tri-Flex®
The Original, Best in Class Underlayment	Meets the Challenges Inherent in Metal Roofs	Designed for Extreme Temperature Roof Assemblies	A Better Alternative to Granulars	Overcomes Deficiencies of #15 FELT	Overcomes Deficiencies of #30 FELT
Key Benefits <ul style="list-style-type: none"> • Strong Adhesion to the Roof Deck – Ensures watertight seal • High Quality Seal Around Roofing Fasteners – Delivers best in class roof leak protection • Forms Superior Laps – Provides watertight installation with NO special treatment of the laps • Ripcord® – Split Release on Demand – Makes it easier to waterproof detail areas such as valleys, chimneys and roof to wall transitions 	<ul style="list-style-type: none"> • Temperature Resistance up to 260°F – Perfect option for high temperature roof designs such as metal roofs • 120 Day Exposure – Membrane delivers consistent performance over long, unpredictable construction cycles • High Quality Seal Around Fasteners – Premium roof leak protection • Strong Adhesion – Ensures watertight seal • Strong Lap Strength – Minimizes chances of leaks due to gaps 	<ul style="list-style-type: none"> • Heat Resistance up to 300°F – 100% butyl adhesive is ideal for use in elevated temperatures for copper, zinc, and COR-TEN® roofs, or any application where superior heat resistance is required • Superior Protection for Expensive Metal Roofs – Protect your clients' high end roof coverings with Grace Ultra's unique solution • Membrane bonds firmly to roof deck and forms high quality laps – Ensures watertight seal and premium leak protection • Compatible with roofing materials – Provides watertight transition between low slope and steep slope roofs 	<p>Compared to Granulars:</p> <ul style="list-style-type: none"> • Light Weight – Great performance with minimal weight • Superior Lap Adhesion – Better protection against leaks • Re-rodable – Shingles can be easily removed from existing Grace Select underlayment during re-roofing • Higher adhesive content; no fill-ers – Strong defense against wind-driven rain and ice dams • Proprietary Film Surface – Superior foot traction without loose granules; scuff free surface 	<p>Compared to #15 felt:</p> <ul style="list-style-type: none"> • Stronger (10 times) – Withstands higher wind conditions • Lighter weight – Fast and easy installation • More Coverage per Roll (2.3 times) – Increased efficiency • Slip Resistant Surface – Provides superior foot traction • 100% Recyclable – Contributes to sustainability and LEED 	<p>Compared to #30 felt:</p> <ul style="list-style-type: none"> • More Coverage per Roll (5 times) – Increased efficiency • Durable – Can be left exposed up to 6 months • Stronger (20 times) – Can withstand higher wind conditions • Lighter weight – Fast and easy installation • Slip Resistant Surface – Superior foot traction
Temperature Resistance	180°F	260°F	300°F	180°F	N/A
Exposure	30 days	120 days	60 days	30 days	30 days
Size	108 SF, 200 SF, 225 SF Rolls	200 SF, 225 SF Rolls	198 SF Rolls	195 SF Rolls	10 Square Rolls

We hope the information here will be helpful. It is based on data and knowledge considered to be true and accurate and is offered for the users' consideration. Investigation and verification, but we do not warrant the results to be obtained. Please read all statements, recommendations or suggestions in conjunction with our conditions of sale, which apply to all goods supplied by us.

GRACE®, RIPCORD®, TRI-FLEX®, ICE AND WATER SHIELD® are trademarks, registered in the United States and/or other countries, of W. R. Grace & Co.-Conn. GRACE SELECT™, GRACE SYN 15™, and GRACE ULTRA™ are trademarks of W. R. Grace & Co.-Conn. COR-TEN® is a trademark, registered in the United States and/or other countries, of United States Steel Corporation. This is an independent publication and is not affiliated with, nor has it been authorized, sponsored, or otherwise approved by the aforesaid company. This trademark list has been compiled using available published information as of the publication date of this brochure and may not accurately reflect current trademark ownership or status. Grace Construction Products is a product group of W. R. Grace & Co.-Conn. © Copyright 2013 W. R. Grace & Co. SKU UL-171 Printed in U.S.A. - 11/13 CDD/SG/XX

GRACE Ice & Water Shield®

Roofing Underlayment

The Original, Best In Class Roofing Underlayment



**Excellent protection
against wind driven
rain & ice dams**



**High quality seal
around roofing
fasteners**



**The name
contractors trust the
most to protect their
reputations**

Grace® Ice & Water Shield® fully-adhered smooth surface roofing underlayment provides best in class roof leak protection. Its proprietary and time tested rubberized asphalt formulation has been proven to form a watertight bond with the roof deck and to seal around fasteners used to attach roof coverings. When it comes to roof protection, insist on the original – Grace Ice & Water Shield® roofing underlayment.

“Grace Ice & Water Shield® is the brand that I have trusted the most over the last 19 years when it comes to roofing underlayments. I rely on its superior ability to protect the most vulnerable roof details from ice dams and wind driven rains.”

— Mark Cahill, President of Cahill Roofing Inc.



Why **GRACE** ICE & WATER SHIELD® Roofing Underlayment?



Longest Performance History—

With over 35 years of performance history, Grace® Ice & Water Shield® fully-adhered underlayment offers the highest confidence for the life of the roof



Strong Adhesion to the Roof Deck

Helps ensure watertight seal

Protect clients' roofs from harsh weather conditions

High quality seal around roofing fasteners—

Delivers best in class roof leak protection

Peace of mind against costly call backs

Forms Superior Laps—

Provides watertight installation with NO special treatment of the laps

Premium leak protection without additional labor time

Ripcord® Split Release on Demand—

Makes it easier to waterproof detail areas such as valleys, chimneys, roof to wall transitions

Robust protection of the roof's most vulnerable areas

Roll Coverage	225 ft ²
	200 ft ²
	108 ft ²

www.graceresidential.com

For additional information on Grace's Residential Waterproofing, call: 1-866-333-3SBM

GRACE, ICE & WATER SHIELD®, RIPCORD® are trademarks, registered in the United States and/or other countries, of W. R. Grace & Co.-Conn. This trademark list has been compiled using available published information as of the publication date of this brochure and may not accurately reflect current trademark ownership or status. Grace Construction Products is a business segment of W. R. Grace & Co.-Conn.

We hope the information here will be helpful. It is based on data and knowledge considered to be true and accurate and is offered for the users' consideration, investigation and verification, but we do not warrant the results to be obtained. Please read all statements, recommendations or suggestions in conjunction with our conditions of sale, which apply to all goods supplied by us. No statement, recommendation or suggestion is intended for any use which would infringe any patent or copyright. W. R. Grace & Co.-Conn., 62 Whittemore Avenue, Cambridge, MA 02140. In Canada, Grace Canada, Inc., 294 Clements Road, West, Ajax, Ontario, Canada L1S 3C6.

Copyright 2013. W. R. Grace & Co.-Conn. GIWS-222 Printed in U.S.A. 04/14 GCS/PDF

GRACE

GRACE Ice & Water Shield® HT

Roofing Underlayment

Meets The Challenges Inherent in Metal Roofs



Delivers optimal balance of adhesion & thermal stability for superior performance under the most demanding conditions



Protects roofs against wind driven rain and ice dams



The design flexibility you need, the waterproofing performance you trust

Grace® Ice & Water Shield® HT fully-adhered, smooth surface roofing underlayment is specifically designed to meet the challenges inherent in metal roof assemblies. It delivers all the advantages of Grace Ice and Water Shield® roofing underlayment with thermal stability up to 260°F.

“Grace underlayments are far superior to any products we have used in the past. When applied properly they perform flawlessly. They adhere very well to roof decks and seal each and every nail penetration unlike many other products we have used in the past. We use Grace Ice & Water Shield® HT under all of our slate roof applications. Since 1989, we have been using Grace underlayments, and we are highly satisfied with their products. In the event of a roofing failure (snow and ice, hurricane, tree damage, etc.) we feel confident having Grace underlayments on our clients’ homes and would trust no other product. Do it right the first time.”

— Kevin Menezes, Triple M Contracting Inc.



Why **GRACE ICE & WATER SHIELD® HT** Roofing Underlayment?



Developed by Grace

Premium protection you expect from Grace Ice and Water Shield® roofing underlayment with the thermal stability metal roofs require

Roll Coverage	225 ft ² 200 ft ²
Temp. Resistance	260° F
Exposure Time	120 days

Temperature resistance up to 260°F—

Perfect option for high temperature roof designs such as metal roofs

Premium waterproofing for metal roofs

120 day exposure—

Membrane delivers consistent performance over long, unpredictable construction cycles

Flexible construction schedules

High quality seal around fasteners—

Premium roof leak protection

Peace of mind against costly call backs

Superior adhesion—

Helps ensure watertight seal

Protection from harsh weather conditions

Strong lap strength—

Minimizes chances of leaks due to gaps

Vulnerable lap areas are protected

www.graceresidential.com

For additional information on Grace's Residential Waterproofing, call: 1-866-333-3SBM

Grace' and ICE & WATER SHIELD' are trademarks, registered in the United States and /or other countries of W.R. Grace & Co.-Conn. This trademark list has been compiled using available published information as of the publication date of this brochure and many not accurately reflect current trademark ownership of status. Grace Construction Products is a business segment of W.R. Grace & Co.-Conn.

We hope the information here will be helpful. It is based on data and knowledge considered to be true and accurate and is offered for the users' consideration, investigation and verification, but we do not warrant the results to be obtained. Please read all statements, recommendations or suggestions in conjunction with our conditions of sale, which apply to all goods supplied by us. No statement, recommendation or suggestion is intended for any use which would infringe any patent or copyright. W. R. Grace & Co.-Conn., 62 Whittemore Avenue, Cambridge, MA 02140. In Canada, Grace Canada, Inc., 294 Clements Road, West, Ajax, Ontario, Canada L1S 3C6.

Copyright 2014. W. R. Grace & Co.-Conn. GIWS-223 Printed in U.S.A. 04/14 GCS/PDF



GRACE ULTRA™

Roofing Underlayment

Designed For Extreme Temperature Roof Assemblies



Ideal for copper,
zinc, and
COR-TEN® Roofs



Excellent for high
altitude and desert
climates



Backed by Grace
The name that
roofing professionals
trust

Grace® Ultra™ self-adhered, smooth surface roofing underlayment features a 100% butyl adhesive formula. Grace Ultra™ roofing underlayment delivers best in-class water protection in applications, where withstanding high in-service temperatures for extended periods of time is required.

“Grace® underlayments are far superior to any product we have used in the past. When applied properly they perform flawlessly. They adhere very well to roof decks and seal each and every nail penetration unlike many other products we have used in the past.”

—Kevin Menezes of Triple M Contracting Inc.



Why **GRACE ULTRA™** Roofing Underlayment?



A unique waterproofing solution that matches the long term durability of copper roofs



Heat Resistance up to 300°F—

100% butyl adhesive is perfect for use in elevated temperatures, in hot desert Southwest climates or any application, where superior heat resistance is required

Peace of mind against extreme conditions

Superior Protection for Expensive Metal Roofs -

Protect your clients' high end roof coverings with Grace Ultra™ roofing underlayment's unique solution

High quality protection for high quality jobs

Membrane bonds firmly to roof deck and forms high quality laps—

Ensures watertight seal and premium leak protection

Do the job right the first time

Compatible with roofing materials—

Provides watertight transition between low slope & steep slope roofs

Don't compromise waterproof integrity due to material compatibility

Roll Size	34 in. x 70 ft.
Roll Coverage	198 SF
Temperature Resistance	300°F

www.graceresidential.com

For additional information on Grace's Residential Waterproofing, call: 1-866-333-3SBM

GRACE is a trademark, registered in the United States and/or other countries, of W. R. Grace & Co.-Conn. GRACE ULTRA™ is a trademark of W. R. Grace & Co.-Conn. COR-TEN is a trademark, registered in the United States and/or other countries, of United States Steel Corporation. This is an independent publication and is not affiliated with, nor has it been authorized, sponsored, or otherwise approved by the aforesaid company. This trademark list has been compiled using available published information as of the publication date of this brochure and may not accurately reflect current trademark ownership or status. Grace Construction Products is a business segment of W. R. Grace & Co.-Conn.

We hope the information here will be helpful. It is based on data and knowledge considered to be true and accurate and is offered for the users' consideration, investigation and verification, but we do not warrant the results to be obtained. Please read all statements, recommendations or suggestions in conjunction with our conditions of sale, which apply to all goods supplied by us. No statement, recommendation or suggestion is intended for any use which would infringe any patent or copyright. W. R. Grace & Co.-Conn., 62 Whittemore Avenue, Cambridge, MA 02140. In Canada, Grace Canada, Inc., 294 Clements Road, West, Ajax, Ontario, Canada L1S 3C6.

Copyright 2014. W. R. Grace & Co.-Conn. UL-172 Printed in U.S.A. 04/14 GCS/PDF

GRACE

GRACE SELECT™

Roofing Underlayment

A Better Alternative to Granulars



Offers higher performance benefits at similar price point



Protects roofs against wind driven rain and ice dams



Backed by Grace- The name that roofing professionals trust

Grace® Select™ smooth surface roofing underlayment is composed of a rubberized asphalt adhesive laminated to a strong slip-resistant film. It meets the industry standards for fastener sealability equivalent to granular products, while it provides fast and easy installation.

“After using several brands of granular underlayments over the years, I am glad I discovered Grace Select. Select is definitely better than any granular underlayments out there and does a much better job. Since it is lightweight, it is easier to work with. Also, it is made by Grace, which gives me peace of mind that my clients’ roofs are well protected. Overall, I am very satisfied with Grace Select.”

— Mario Sousa, Caliber Construction



Why GRACE® SELECT™ Roofing Underlayment?



Developed
by Grace®

the recognized
leader in
self-adhered
roofing
underlayments
and the
manufacturer
of Grace Ice &
Water Shield®



GRACE SELECT™

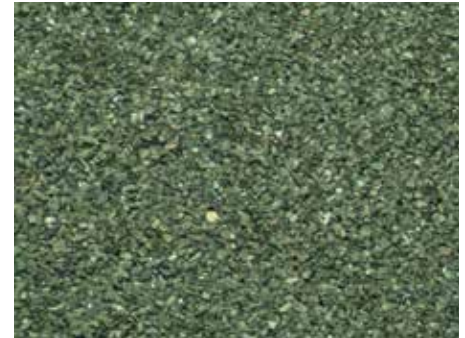

GRANULARS

Light weight—
Great performance with minimal weight
Fast and easy installation

Double weight—
Difficult to handle during
installation

Superior lap adhesion—
Better protection against leaks
Job done well the first time

**Granular surface may
inhibit watertight laps—**
May require special treatment
of the laps

Re-roofable—
Shingles can be easily removed from
existing Select underlayment during
re-roofing
Easier & less costly retrofit applications

Not re-roofable—
Shingles cannot be easily removed from
the existing granular underlayment
when re-roofing; more difficult & costly
retrofit jobs

Higher adhesive content; no fillers—
Strong defense against wind-driven
rain and ice dams
Protection against costly call backs

**Lower adhesive
and higher filler
content is typical**

Proprietary film surface—
Superior foot traction without loose
granules; scuff free surface
Safe & Clean Installation

Granular surface—
Loose granules may cause slip
hazards; may be vulnerable to scuffing
in hot weather

Roll Weight	32 lbs.
Roll Size	195 ft ²
Roll Length	65 ft.
Roll Width	36 in.

www.graceresidential.com

**For additional information on Grace's Residential Waterproofing,
call: 1-866-333-3SBM**

GRACE® and Ice & Water Shield® are trademarks, registered in the United States and/or other countries, of W. R. Grace & Co.-Conn. GRACE Select™ is a trademark of W. R. Grace & Co.-Conn. This trademark list has been compiled using available published information as of the publication date of this brochure and may not accurately reflect current trademark ownership or status. Grace Construction Products is a business segment of W. R. Grace & Co.-Conn.

We hope the information here will be helpful. It is based on data and knowledge considered to be true and accurate and is offered for the users' consideration, investigation and verification, but we do not warrant the results to be obtained. Please read all statements, recommendations or suggestions in conjunction with our conditions of sale, which apply to all goods supplied by us. No statement, recommendation or suggestion is intended for any use which would infringe any patent or copyright. W. R. Grace & Co.-Conn., 62 Whittemore Avenue, Cambridge, MA 02140. In Canada, Grace Canada, Inc., 294 Clements Road, West, Ajax, Ontario, Canada L1S 3C6.

© Copyright 2014. W. R. Grace & Co.-Conn. UL-168A Printed in U.S.A. 04/14 GCS/PDF

GRACE

GRACE TRI-FLEX[®]

Synthetic Roofing Underlayment

Overcomes Deficiencies of #30 Felt



**Robust benefits
compared to #30 Felt**



**High performance
water-shedding
underlayment**



**Backed by Grace-
The name
that roofing
professionals trust**

Grace[®] Tri-Flex[®] mechanically-attached, synthetic roofing underlayment is designed to overcome the shortcomings of traditional roofing felt, while delivering advanced benefits that save the contractor time & labor.

“I Install Grace Tri-Flex[®] synthetic underlayment whenever I install Grace Ice & Water Shield[®]. I found that Grace Tri-Flex works better than any other synthetic roofing underlayment I’ve used. The fact that it is a wrinkle free, tear resistant product makes it easy to apply to the deck. I install roofs in the North Shore and South Shore areas of Boston and need materials that can withstand the inclement weather.”

— TJ Livingstone, Land Line Construction Inc.



Why **GRACE TRI-FLEX®** Roofing Underlayment?



20 Times Stronger than Felt

Grace Tri-Flex® roofing underlayment can withstand high wind conditions, providing peace of mind against costly reworks.



GRACE® TRI-FLEX®



#30 FELT

More coverage per roll (5 times)—
Increased efficiency
Labor Savings

Less coverage—
Requires more rolls to cover the same area

Durable –
Long exposure time allows temporary “dry in” of structures for up to 6 months
Flexible construction schedules

Less durable—
Exposure degrades quality of felt

Lighter weight—
Fast and easy installation
Saves time & labor costs

Double weight—
Difficult to handle during installation

Slip Resistant Surface—
Superior foot traction
Safer installation

Less slip resistant—
Can be slippery when wet

Roll Coverage	10 square
Roll Weight	28 lbs
Exposure	180 days

www.graceresidential.com

For additional information on Grace’s Residential Waterproofing, call: 1-866-333-3SBM

GRACE® and Tri-Flex® are trademarks, registered in the United States and/or other countries, of W. R. Grace & Co.-Conn. This trademark list has been compiled using available published information as of the publication date of this brochure and may not accurately reflect current trademark ownership or status. Grace Construction Products is a business segment of W. R. Grace & Co.-Conn.

We hope the information here will be helpful. It is based on data and knowledge considered to be true and accurate and is offered for the users’ consideration, investigation and verification, but we do not warrant the results to be obtained. Please read all statements, recommendations or suggestions in conjunction with our conditions of sale, which apply to all goods supplied by us. No statement, recommendation or suggestion is intended for any use which would infringe any patent or copyright. W. R. Grace & Co.-Conn., 62 Whittemore Avenue, Cambridge, MA 02140. In Canada, Grace Canada, Inc., 294 Clements Road, West, Ajax, Ontario, Canada L1S 3C6.

Copyright 2014. W. R. Grace & Co.-Conn. UL-173 Printed in U.S.A. 04/14 GCS/PDF



GRACE SYN 15™

Roofing Underlayment

Overcomes Deficiencies of #15 Felt



Superior performance compared to #15 Felt



Resists blow-offs & tears in windy conditions



Backed by Grace-
The name that roofing professionals trust



Grace® Syn 15™ is a mechanically-attached, synthetic roofing underlayment. It is designed to overcome the shortcomings of #15 felt, while delivering advanced benefits that save you time & labor.



Why **GRACE SYN 15™** Roofing Underlayment?



Light Weight

Grace® SYN 15™ synthetic underlayment weighs half of #15 felt, enabling fast and easy installation

Roll Coverage	10 square
Roll Weight	20 lbs



GRACE® SYN 15™



#15 FELT

<p>Stronger (10 times) — Withstands higher wind conditions <i>Protection against costly repairs</i></p>	<p>Vulnerable to wind — Higher chance for rework</p>
<p>More coverage per roll (2.3 times) — Increased efficiency <i>Labor savings</i></p>	<p>Less coverage — Requires more rolls to cover the same amount of area</p>
<p>Slip resistant surface — Provides superior foot traction <i>Safer installation</i></p>	<p>Less slip resistant— Can be slippery when wet</p>

100% Recyclable —
Contributes to sustainability & LEED

Cannot be Recycled

www.graceresidential.com

For additional information on Grace's Residential Waterproofing, call: 1-866-333-3SBM

GRACE® is a trademark, registered in the United States and/or other countries, of W. R. Grace & Co.-Conn. GRACE Syn 15™ is a trademark of W. R. Grace & Co.-Conn. This trademark list has been compiled using available published information as of the publication date of this brochure and may not accurately reflect current trademark ownership or status. Grace Construction Products is a business segment of W. R. Grace & Co.-Conn.

We hope the information here will be helpful. It is based on data and knowledge considered to be true and accurate and is offered for the users' consideration, investigation and verification, but we do not warrant the results to be obtained. Please read all statements, recommendations or suggestions in conjunction with our conditions of sale, which apply to all goods supplied by us. No statement, recommendation or suggestion is intended for any use which would infringe any patent or copyright. W. R. Grace & Co.-Conn., 62 Whittemore Avenue, Cambridge, MA 02140. In Canada, Grace Canada, Inc., 294 Clements Road, West, Ajax, Ontario, Canada L1S 3C6.

Copyright 2014. W. R. Grace & Co.-Conn. UL-174A Printed in U.S.A. 12/14 GCS/PDF





Weather Resistive Barriers & Flashings

.....

Vycor® enV-S™

Vycor enV®

Vycor® Plus

Vycor® PRO

GRACE VYCOR® enV-S™

Weather Resistive Barrier

Better Weather Protection than Housewraps



Protection against water and air intrusion that cannot be matched by mechanically-attached housewraps



Seals to the substrate, seals to itself, seals around nails



Helps achieve up to 56% annual energy savings*

Vycor® enV-S™ sheet-applied, fully-adhered weather resistive barrier provides exceptional protection against water damage and air infiltration. It helps preserve the home's structural integrity and contributes to improved energy efficiency.

"We installed Vycor enV-S and were extremely pleased with its air infiltration performance compared to traditional housewraps. Our energy tester noted that this was the lowest test rate they had performed in our area. With Grace® Vycor enV-S, we are well on our way to achieving our energy efficiency goal of 1ACH leakage."

— Perry Des Jardins, Des Jardins Custom Design Build

*Per "Testing of Grace Vycor® enV-S™ Weather Resistive Barrier", by Oak Ridge National Laboratory



Complete Weather Protection

Robust weatherization system when combined with Vycor® Flashings

Why GRACE VYCOR® enV-S™ Weather Resistive Barrier?



VYCOR® enV-S™ is fully-adhered....

Forms continuous barrier against water and air leakage, sealing all the critical entry points—

Differentiate yourself by offering clients premium protection against water damage and helping them lower their utility bills

Installation does not require mechanical fasteners or taping of seams—

Provides peace of mind during installation; no worrying about leaks caused by improperly installed “details”

Strong adhesion to substrate allows the sheet to withstand weather conditions during the construction period—

Avoid costly reworks due to tears & blow-offs, which are typical for housewraps

Professional, aesthetically-appealing appearance on the house during the exposure period—

Quality products for quality builders

Roll Size	40 in. x 135 ft.
Roll Coverage	450 ft ²
UV Exposure	90 days

www.graceresidential.com

For additional information on Grace’s Residential Waterproofing, call: 1-866-333-3SBM

GRACE®, Vycor® and Vycor enV® are trademarks, registered in the United States and/or other countries, of W. R. Grace & Co.-Conn. This trademark list has been compiled using available published information as of the publication date of this brochure and may not accurately reflect current trademark ownership or status. Grace Construction Products is a business segment of W. R. Grace & Co.-Conn.

We hope the information here will be helpful. It is based on data and knowledge considered to be true and accurate and is offered for the users’ consideration, investigation and verification, but we do not warrant the results to be obtained. Please read all statements, recommendations or suggestions in conjunction with our conditions of sale, which apply to all goods supplied by us. No statement, recommendation or suggestion is intended for any use which would infringe any patent or copyright. W. R. Grace & Co.-Conn., 62 Whittemore Avenue, Cambridge, MA 02140. In Canada, Grace Canada, Inc., 294 Clements Road, West, Ajax, Ontario, Canada L1S 3C6.

Copyright 2014. W. R. Grace & Co.-Conn. WRB-010A Printed in U.S.A. 04/14 GCS/PDF

GRACE

GRACE VYCOR *enV*[®]

Weather Resistive Barrier

Solves the Challenges of Housewraps & Building Papers



Protection against water and air intrusion that cannot be matched by mechanically attached housewraps



Fully-adhered and continuous nail sealable protection



Vapor permeable quality maintains “breathable” characteristic of walls

Vycor enV[®] liquid-applied, fully-adhered weather resistive barrier provides exceptional protection against water damage and air infiltration, preserving the home’s thermal performance and structural integrity. Vycor enV[®] can be either spray or roller-applied.

“I found that Vycor enV[®] is much easier to install than housewraps, especially on rehab jobs. The product met my needs for ease of installation and met the new energy codes. And it met the homeowner’s need for energy efficiency.”

— Michael Lapointe, Michael Lapointe General Contracting

Why **GRACE VYCOR enV[®]** Weather Resistive Barrier?



System Solution

Excellent weatherization system when combined with Vycor enV[®] tape and Vycor[®] Flashings



VYCOR enV[®] is fully-adhered

Water Resistant & Vapor Permeable—

Reduces risk of moisture related problems

Enhanced building durability & indoor air quality; lower maintenance costs

Air Resistant—

Limits air flow both into and out of the building envelope

Lower energy costs

Seamless Fluid-Applied Protection —

Makes detailing easy

High performance, efficient application

Durable—

Resistance to tearing, UV exposure & other construction related damage

Protection against re-work costs

Packaging Size	5 Gallon Pail
UV Exposure	120 Days

www.graceresidential.com

For additional information on Grace's Residential Waterproofing, call: 1-866-333-3SBM

GRACE, VYCOR, VYCOR enV[®] are trademarks, registered in the United States and/or other countries, of W. R. Grace & Co.-Conn. This trademark list has been compiled using available published information as of the publication date of this brochure and may not accurately reflect current trademark ownership or status. Grace Construction Products is a business segment of W. R. Grace & Co.-Conn.

We hope the information here will be helpful. It is based on data and knowledge considered to be true and accurate and is offered for the users' consideration, investigation and verification, but we do not warrant the results to be obtained. Please read all statements, recommendations or suggestions in conjunction with our conditions of sale, which apply to all goods supplied by us. No statement, recommendation or suggestion is intended for any use which would infringe any patent or copyright. W. R. Grace & Co.-Conn., 62 Whittemore Avenue, Cambridge, MA 02140. In Canada, Grace Canada, Inc., 294 Clements Road, West, Ajax, Ontario, Canada L1S 3C6.

Copyright 2014. W. R. Grace & Co.-Conn. WRB-012 Printed in U.S.A. 04/14 GCS/PDF

GRACE

GRACE VYCOR® PLUS

Window & Door Flashing

Premium Water Protection for Windows



Protects vulnerable details from moisture penetration

Limits air leakage around windows & doors

Forms a water & air seal with building materials

Vycor® Plus is a high performance self-adhered flashing, that provides premium protection against water infiltration in critical details such as windows and doors. When properly installed, Vycor® Plus flashing reduces the risk of mold and rot development, and contributes to energy efficiency.

“I’ve been in the building industry for over 30 years and have never received a call back on leaking windows after I started using Grace Vycor® Plus flashing tape. Easy to install and the peace of mind of knowing that if I do get a callback, it is not because of water leaking from the window flashing. I was the Superintendent on a project where we built 47 condos on the water in Avalon, NJ. Even after hurricane Sandy, we didn’t get a call back on water leaking from around the windows. Great product and highly recommended.”

—Jerry Giles, Ehret Construction



Proven Track Record

Vycor® Plus flashing
employs the same
proven technology as
Grace® Ice & Water
Shield® – the leader in
roofing underlayments
for over 35 years

Roll Width	4 in., 6 in., 9 in., 12 in., 18 in.
Roll Length	75 ft.

Why GRACE VYCOR® PLUS Flashing?



Superior Adhesion to Substrate—

Forms strong waterproof bond

Protect clients' walls against mold, mildew and rot

Seals Around Fasteners—

Prevents water penetration to the substrate

Give clients peace of mind with premium protection

Forms Superior Laps—

Ensures strong laps even at seams in the flashing

Another defense against moisture intrusion

Ripcord® and Measurement Markings—

Enables fast and easy installation

Opportunity to flash more windows

Highly Conformable and Flexible—

Accommodates settlement and shrinkage movement

Premium protection even in hard to work areas

www.graceresidential.com

For additional information on Grace's Residential Waterproofing, call: 1-866-333-3SBM

GRACE®, ICE & WATER SHIELD®, VYCOR®, RIPCORD® are trademarks, registered in the United States and/or other countries, of W. R. Grace & Co.-Conn. This trademark list has been compiled using available published information as of the publication date of this brochure and may not accurately reflect current trademark ownership or status. Grace Construction Products is a business segment of W. R. Grace & Co.-Conn.

We hope the information here will be helpful. It is based on data and knowledge considered to be true and accurate and is offered for the users' consideration, investigation and verification, but we do not warrant the results to be obtained. Please read all statements, recommendations or suggestions in conjunction with our conditions of sale, which apply to all goods supplied by us. No statement, recommendation or suggestion is intended for any use which would infringe any patent or copyright. W. R. Grace & Co.-Conn., 62 Whittemore Avenue, Cambridge, MA 02140. In Canada, Grace Canada, Inc., 294 Clements Road, West, Ajax, Ontario, Canada L1S 3C6.

Copyright 2014. W. R. Grace & Co.-Conn. TP-161 Printed in U.S.A. 04/14 GCS/PDF

GRACE

GRACE VYCOR[®] PRO

Window & Door Flashing

High-Performance Non-Asphaltic Protection for Windows and Doors



Proprietary adhesive seals and protects details against moisture and air intrusion



Compatible with flexible PVC windows and leading sealant technologies



Wide application temperature range for year round versatility in any climate

Grace[®] Vycor[®] PRO flashing, with its highly conformable film and non-asphaltic, butyl-modified adhesive technology, provides premium protection against water infiltration in all critical non-roof detail areas. Vycor Pro contains no asphalt and is compatible with flexible PVC window flanges and leading sealant technologies.



Why **GRACE VYCOR® PRO** Flashing?



Complete Weatherization System When used with Vycor enV® or Vycor® enV-S™ weather resistive barriers



Non-Asphaltic Butyl-Modified Adhesive—

Compatible with flexible PVC window flanges and leading sealant technologies.

Chemical compatibility concerns are eliminated

Seals Around Fasteners—

Prevents water penetration to the substrate

Give clients peace of mind with premium protection

Aggressive Butyl-Modified Adhesive—

Forms strong laps and bonds aggressively to the substrate, even in cold conditions

Versatility for use in all seasons

Highly Conformable Thin Membrane—

Easily worked into tight details with minimal build-up of multiple layers

Premium protection even in hard to work areas

Convenient Measurement Markings—

Makes preparation faster and easier

Save time - Save money

Membrane Thickness	14 mils
Roll Width	4 in., 6in., 9 in., 12 in.,
Roll Length	75 ft.

www.graceresidential.com

For additional information on Grace's Residential Waterproofing, call: 1-866-333-3SBM

GRACE, VYCOR, RIPCORDER, Vycor enV-S are trademarks, registered in the United States and/or other countries, of W. R. Grace & Co.-Conn. This trademark list has been compiled using available published information as of the publication date of this brochure and may not accurately reflect current trademark ownership or status. Grace Construction Products is a business segment of W. R. Grace & Co.-Conn.

We hope the information here will be helpful. It is based on data and knowledge considered to be true and accurate and is offered for the users' consideration, investigation and verification, but we do not warrant the results to be obtained. Please read all statements, recommendations or suggestions in conjunction with our conditions of sale, which apply to all goods supplied by us. No statement, recommendation or suggestion is intended for any use which would infringe any patent or copyright. W. R. Grace & Co.-Conn., 62 Whittemore Avenue, Cambridge, MA 02140. In Canada, Grace Canada, Inc., 294 Clements Road, West, Ajax, Ontario, Canada L1S 3C6.

Copyright 2014. W. R. Grace & Co.-Conn. TP-162 Printed in U.S.A. 08/14 GCS/PDF





Basement Waterproofing and Vapor Barriers

.....

Grace Bituthene®
Grace Florprufe®

GRACE BITUTHENE®

Waterproofing Membrane

Waterproofing for Basement Walls



Provides a continuous layer of waterproofing, protecting from leaks coming through cracks in the foundation

Protects against aggressive soils and ground water

Durable and easy to apply sheet

Grace® Bituthene® fully-adhered waterproofing membrane is applied to the outside of basement walls. Its cross-laminated film ensures a waterproof seal. Protect your project with Grace Bituthene® waterproofing membrane for a durable and watertight below-grade solution.

“W.R. Grace’s Bituthene® is RSI’s first choice in sheet waterproofing. Bituthene’s high quality, ease of installation, and immediate availability make it a worry-free waterproofing application. Whether we are using it to waterproof a basement at the University of Colorado Recreation Center or as part of the Composite Waterproofing System at Denver International Airport, Bituthene is an important component in our waterproofing arsenal and a vital first step in a building envelope system.”

—Chad Hinshaw, Project Manager, Restoration Specialists Inc



Why GRACE BITUTHENE®?



From Grace

The global leader in waterproofing technologies for over 50 years



Fully Adhered—

Forms integral bond to substrate

Keeps basement dry and comfortable

Flexible—

Accommodates minor settlement and shrinkage movement

Maintains waterproof seal

Cross Laminated Film—

Dimensional stability, high tear strength, puncture and impact resistance

Highly durable material

Ripcord® – Split Release on Demand—

Ease of membrane positioning in detailed areas

Robust protection in hard to install areas

Roll Length	66.7 ft.
Roll Width	3 ft.
Roll Size	200 ft ²
Roll Weight	83 lbs.

www.graceresidential.com

For additional information on Grace's Residential Waterproofing, call: 1-866-333-3SBM

GRACE®, Bituthene® and Ripcord® are trademarks, registered in the United States and/or other countries, of W. R. Grace & Co.-Conn. This trademark list has been compiled using available published information as of the publication date of this brochure and may not accurately reflect current trademark ownership or status. Grace Construction Products is a business segment of W. R. Grace & Co.-Conn.

We hope the information here will be helpful. It is based on data and knowledge considered to be true and accurate and is offered for the users' consideration, investigation and verification, but we do not warrant the results to be obtained. Please read all statements, recommendations or suggestions in conjunction with our conditions of sale, which apply to all goods supplied by us. No statement, recommendation or suggestion is intended for any use which would infringe any patent or copyright. W. R. Grace & Co.-Conn., 62 Whittemore Avenue, Cambridge, MA 02140. In Canada, Grace Canada, Inc., 294 Clements Road, West, Ajax, Ontario, Canada L1S 3C6.



GRACE FLORPRUFE®

Vapor Barrier

Premium vapor protection for basement floor finishes



Helps keep
basement areas dry
& comfortable



Enables your
client to finish the
basement area with
the floor covering of
their choice



Protects the living
space and increases
its durability



Florprufe® high performance vapor barrier is designed with Grace's Advanced Bond Technology™, forming a unique seal to the underside of concrete floor slabs. Florprufe® membrane protects expensive moisture sensitive flooring products from the effects of water vapor migrating upward through the slab and causing water damage.



Why **GRACE FLORPRUFE®** Vapor Barrier?



From Grace

The leader in waterproofing technologies and solutions



Powerful Seal to the underside of concrete slabs—

Provides fully-adhered protection, even if ground settlement occurs

Keeps basement dry and comfortable

Lightweight kick-out rolls —

Easy to apply

Saves time and labor

Low vapor permeability —

Protects vapor sensitive flooring materials

Gives design flexibility on choice of flooring materials

Roll Length	115 ft.
Roll Width	4 ft.
Roll Size	460 ft ²
Roll Weight	70 lbs.

www.graceresidential.com

For additional information on Grace's Residential Waterproofing, call: 1-866-333-3SBM

GRACE® and Florprufe® are trademarks, registered in the United States and/or other countries, of W. R. Grace & Co.-Conn. This trademark list has been compiled using available published information as of the publication date of this brochure and may not accurately reflect current trademark ownership or status. Grace Construction Products is a business segment of W. R. Grace & Co.-Conn.

We hope the information here will be helpful. It is based on data and knowledge considered to be true and accurate and is offered for the users' consideration, investigation and verification, but we do not warrant the results to be obtained. Please read all statements, recommendations or suggestions in conjunction with our conditions of sale, which apply to all goods supplied by us. No statement, recommendation or suggestion is intended for any use which would infringe any patent or copyright. W. R. Grace & Co.-Conn., 62 Whittemore Avenue, Cambridge, MA 02140. In Canada, Grace Canada, Inc., 294 Clements Road, West, Ajax, Ontario, Canada L1S 3C6.

Copyright 2014. W. R. Grace & Co.-Conn. PF-198 Printed in U.S.A. 04/14 GCS/PDF





Product Data Sheets

.....

Grace Ice & Water Shield®
Grace Ice & Water Shield® HT
Grace Ultra™
Grace Select™
Grace Tri-Flex®
Grace Syn 15™
Grace Roof Detail Membrane
Vycor® enV-S™
Vycor® enV®

Vycor® Plus
VYcor® PRO
Vycor® V40
Vycor® Aluminum Flashing
Grace Bituthene®
Grace Florprufe®
Perm-A-Barrier® Primer Plus
Perm-A-Barrier® WB Primer

GRACE ICE & WATER SHIELD®

Self-adhered roofing underlayment

Product Description

Grace Ice & Water Shield® self-adhered roofing underlayment is a premier membrane composed of two waterproofing materials—an aggressive rubberized asphalt adhesive backed by a layer of high density cross laminated polyethylene. The rubberized asphalt surface is backed with a foldless release paper that protects its adhesive quality. During application, the release paper is easily removed, allowing the rubberized asphalt to bond tightly to the roof deck. In addition, embedded in the membrane is a Ripcord® split release on demand feature.

The full width membrane is supplied in three full-width roll sizes. See the Product Data chart for product information.

Membrane strips are also available in 75 ft (22.9 m) long rolls at widths of 6 in. (150 mm), 9 in. (225 mm), 12 in. (300 mm) and 18 in. (450 mm).

Features & Benefits

Easy to handle and apply—The self-adhesive membrane bonds firmly to the roof deck without heat or special adhesives.

Ripcord® split release on demand is a unique and patented feature that makes Grace Ice & Water Shield® roofing underlayment easier to apply by giving the applicator the option to split the release liner in half. Faster application of the membrane in the straight-aways, as well as ease of membrane positioning in detailed areas (valleys, around dormers, etc.), are just some of the benefits.

Foldless release paper—The foldless release paper provides multiple performance enhancements: fewer edge catches, 180° pull-back, ease of membrane cutting (single cuts) and membrane positioning, quicker “one-man installs” resulting in an easier, more productive release.

Seals around nails—The rubberized asphalt layer in Grace Ice & Water Shield® membrane seals around roofing nails, resisting leakage caused by water back-up behind ice dams, or from wind-driven rain.

Dual barrier protection—Rubberized asphalt and polyethylene are combined to form two waterproofing barriers providing maximum protection.

Membrane will not crack, dry out or rot—Grace Ice & Water Shield® roofing underlayment resists attacks from fungus and bacteria; maintains its integrity for long lasting protection.

Protects under all standard sloped roof

coverings—Grace Ice & Water Shield® roofing underlayment protects under slate, tile, cedar shakes or metal, as well as under conventional asphalt shingles.

Slip resistant surface—Grace Ice & Water Shield® self-adhered membrane has a slip resistant embossed surface to maximize traction and safety for applicators.

Proven track record—Grace Ice & Water Shield® roofing underlayment is the name brand in roofing underlayments with a 35-year track record of protecting roofs from ice dams and wind-driven rain.

Reroofable—Unlike granular surfaced membranes, Grace Ice & Water Shield® smooth surface underlayment will not adhere to the underside of the exposed roof covering. Grace Ice & Water Shield® membrane can be applied over the old Grace underlayment (except over Grace Basik®, Grace Tri-Flex® and Grace SYN 15™). In retrofit applications, making re-roofing easier, less costly (since there is no need for removing the existing underlayment), more durable and environmentally friendly (as the structural deck remains intact avoiding the need to purchase additional wood decking).

Grace technical support—Grace Ice & Water Shield® roofing underlayment is backed by a team of local technical support personnel that help ensure every application goes smoothly.

Guidelines for Use

Grace Ice & Water Shield® roofing membrane is used as an underlayment for sloped roofs to resist water penetration due to water back-up behind ice dams or wind-driven rain. Grace Ice & Water Shield® underlayment also offers leak protection in trouble prone spots like valleys, skylights, protrusions and other flashing areas.



Ice Dams

Grace Ice & Water Shield® roofing underlayment should be used in conjunction with roof designs that minimize ice dam formation. In cold climates, it is particularly important to provide proper insulation and ventilation to reduce the size of ice dams and to avoid interior condensation. Cathedral ceilings must include ventilation between rafters to allow for air flow to a ridge vent. Well ventilated cold roof designs are particularly important in alpine regions to reduce the size of ice dams which could contribute to structural damage.

Several variables will influence the height of ice dams and the membrane coverage required.

- 1. Climate**—The annual snow fall will affect the amount of membrane needed.
- 2. Slope**—On a low slope, ice dams will extend farther inward from the roof edge.
- 3. Overhang**—A wide overhang will require more membrane to reach the appropriate point on the roof.
- 4. Insulation and ventilation**—A very well insulated building with a cold, well ventilated attic will have smaller ice dams.
- 5. Valleys**—Any valleys formed by projections such as dormers or roof direction changes are likely to trap more snow and cause larger ice dams.
- 6. Exposure**—A northern exposure or shaded areas will generally contribute to larger ice dams. While gutters may make it easier for an ice dam to start, large dams can occur on roofs with no gutters.

Removing snow from a roof edge or installing heat cables may not prevent ice dam formation, but may shift the location of the ice dam. Under certain conditions, a dam can form at the edge of the remaining snow.

Local building codes should be consulted for specific requirements.

Installation Procedure

Surface Preparation

Install Grace Ice & Water Shield® roofing underlayment directly on a clean, dry, continuous structural deck. Some suitable deck materials include plywood, wood composition, wood plank,

Use Grace Ice & Water Shield on all of these critical areas

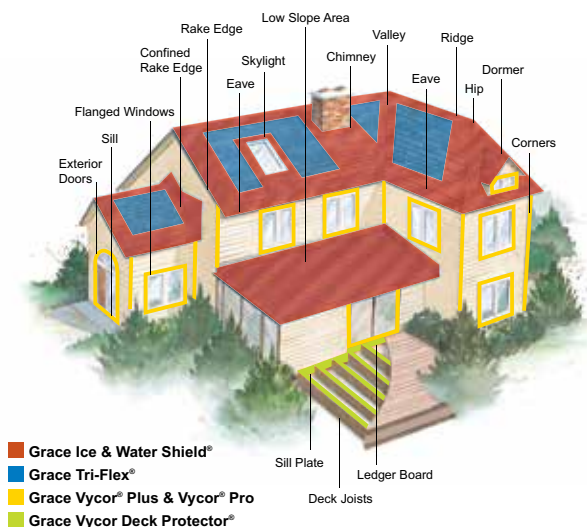

metal, concrete, or gypsum sheathing. Remove dust, dirt, loose nails, and old roofing materials. Protrusions from the deck area must be removed. Decks shall have no voids, damaged, or unsupported areas. Wood planks should be closely butted together. Repair deck areas before installing the membrane.

Prime concrete, masonry surfaces and DensGlass Gold® with Perm-A-Barrier® WB Primer. Prime wood composition and gypsum sheathing with Perm-A-Barrier® WB Primer if adhesion is found to be marginal (*refer to Technical Letter 12, Use on Oriented Strand Board (OSB) Roof Sheathing*). Apply Perm-A-Barrier® WB Primer at a rate of 250–350 ft²/gal (6–8 m²/L). Priming is not required for other suitable surfaces provided that they are clean and dry.

Membrane Installation

Apply Grace Ice & Water Shield® underlayment in fair weather when the air, roof deck, and membrane are at temperatures of 40°F (5°C) or higher. Apply roof covering material at temperatures of 40°F (5°C) or higher.

Cut the membrane into 10–15 ft (3–5 m) lengths and reroll loosely. Peel back 1–2 ft (300–600 mm) of release liner, align the membrane, and continue to peel the release liner from the membrane. Press the membrane in place with heavy hand pressure. Side laps must be a minimum of 3.5 in. (90 mm) and end laps a minimum of 6 in. (150 mm). For valley and ridge application, peel the release liner, center the sheet over the valley or ridge, drape, and press it in place. Work from the center of the valley or ridge outward in each direction and start at the low point and work up the roof.

Alternatively, starting with a full roll of membrane, unroll a 3–6 ft (1–2 m) piece of membrane leaving the release liner in place. Align the membrane and roll in the intended direction of membrane application. Carefully cut the release liner on top of the roll in the cross direction being careful not to cut the membrane. Peel back about 6 in. (150 mm) of the release liner in the opposite direction of the intended membrane application exposing the black adhesive. Hold the release liner with one hand and pull the roll along the deck with the release liner, leaving the applied membrane behind. Use the other hand to apply pressure on the top of the roll. Stop frequently to press the membrane in place with heavy hand pressure. When finished with the roll go back to the beginning, reroll and pull the remaining release paper from the material, finishing the installation.

For successive membrane courses, align the edge of the release liner with the dashed line provided on the surface of the membrane to achieve the 3.5 in. (90 mm) side lap.

Consistent with good roofing practice, install the membrane such that all laps shed water. Always work from the low point to the high point of the roof. Apply the membrane in valleys before the membrane is applied to the eaves. Following placement along the eaves, continue application of the membrane up the roof. The membrane may be installed either vertically or horizontally.

Use smooth shank, electro-plated galvanized nails for fastening shingles to get the best seal. Hand nailing generally provides a better seal than power-activated nailing.

If nailing of the membrane is necessary on steep slopes during hot or extreme cold weather, backnail and cover the nails by overlapping with the next sheet.

Extend the membrane on the roof deck above the highest expected level of water back-up from ice dams and above the highest expected level of snow and ice on the wall sheathing on vertical side walls (dormers) and vertical front walls for ice dam protection. Consider a double layer of membrane

in critical areas, such as along the eaves or in valleys and in climates where severe ice dams are anticipated. Apply the membrane to the entire roof deck for wind-driven rain protection. Apply a new layer of Grace Ice & Water Shield® underlayment directly over the old Grace underlayment in retrofit applications following the standard membrane application procedure.

Precautions & Limitations

- Slippery when wet or covered by frost.
- Consistent with good roofing practice, always wear fall protection when working on a roof deck.
- Release liners are slippery. Remove from work area immediately after membrane application.
- Do not leave permanently exposed to sunlight. Cover within 30 days.
- Place metal drip edges or wood starter shingles over the membrane.
- Do not fold over the roof edge unless the edge is protected by a drip edge, gutter or other flashing material.
- Do not install on the chamfered edges of wood plank.
- Do not install directly on old roof coverings.
- Certain product applications are prohibited in hot desert areas in the southwestern United States. Check with your Grace Construction Products representative.
- Check with the manufacturer of the metal roofing system for any special requirements when used under metal roofing. Do not install directly under roof coverings especially sensitive to corrosion, such as zinc, without providing proper ventilation.
- Do not install under copper, Cor-Ten®, or zinc metal roofing in high altitudes. These roofs can reach extremely high temperatures due to the low reflectivity, high absorption, and high conductivity of the metals. Use Grace Ultra™ underlayment for these roof types. Check with your Grace Construction Products representative.
- Provide proper roof insulation and ventilation to help reduce ice dams and to minimize condensation. Grace Ice & Water Shield® membrane is an air and vapor barrier.
- Repair holes, fishmouths, tears, and damage to membrane with a round patch of membrane extending past the damaged area 6 in. (150 mm) in all directions. If fasteners are removed leaving

holes in the membrane, they must be patched. The membrane may not self-seal open fastener penetrations.

- Do not install fasteners through the membrane over unsupported areas of the structural deck, such as over the joints between adjacent structural panels.
- Due to its slight asphaltic odor, do not apply where the membrane is exposed to interior living space. Refer to product literature for more complete information.
- Not compatible with EPDM or TPO; use Grace Ultra™ underlayment for tie-ins (*refer to Technical Letter 5, Chemical Compatibility*).
- Not compatible with polysulfides, flexible PVC, or high concentrations of resin (pitch). For more information, refer to Technical Letter 5.

Code Compliance

Grace Ice & Water Shield® roofing underlayment meets the following standards:

- Underwriters Laboratories Inc. Class A fire classification under fiber-glass shingles and Class C under organic felt shingles (per ASTM E108/UL 790)
- Underwriters Laboratories Inc. Classified Sheathing Material Fire Resistance Classification with Roof Designs: P225, P227, P230, P237, P259, P508, P510, P512, P514, P701, P711, P717, P722, P723, P732, P734, P736, P742, P803, P814, P818, P824
- Miami-Dade County Product Control Approved. Report NOA 12-1115.02
- Florida State Approval Report No. FL289-R3

Ice Dams

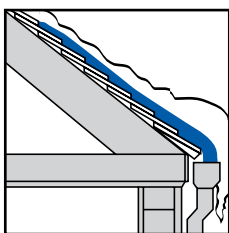

Water from melting snow over the heated portion of the house runs down the roof. It freezes at the cold eave and an ice dam begins to form preventing drainage.

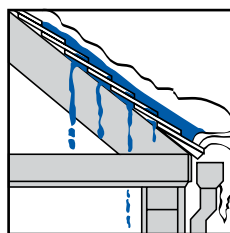

As the ice dam grows, water is trapped behind it and backs up under the shingles. Eventually it reaches the roof deck and leaks through, damaging the interior of the structure.

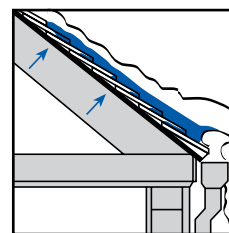

Grace Ice & Water Shield® underlayment resists this leakage because of the seal around the fasteners, ability to make watertight laps, and the membrane's bond to the deck.

Wind-Driven Rain

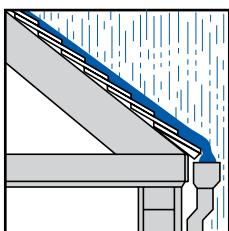

Sloped roofs are not waterproof. They protect structures by shedding rain water.

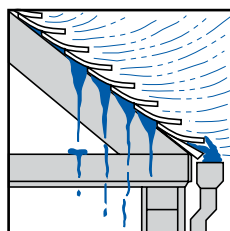

Storm-driven winds can cause sloped roof coverings to lift. Rain can then be easily driven under the roof covering directly to the unprotected roof deck where it causes leaks and damage to the interior of the structure.

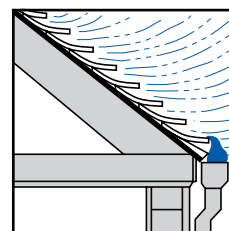

Grace Ice & Water Shield® roofing underlayment applied beneath the sloped roof covering helps prevent wind-driven rain from entering the structure.

Product Data

Roll length	75 ft (22.9 m)	66.6 ft (20.2 m)	36 ft (11.0 m)
Roll width	36 in. (914 mm)	36 in (914 mm)	36 in. (914 mm)
Roll size	225 ft ² (20.9 m ²)	200 ft ² (18.6 m ²)	108 ft ² (10.4 m ²)
Packaging	Corrugated cartons	Corrugated cartons	Corrugated cartons
Roll weight	61.4 lbs (27.9 kg)	55 lbs (24.9 kg)	33.6 lbs (15.3 kg)
Rolls per pallet	35	35	25

Performance Properties

Property	Value	Test Method
Color	Gray-black	
Thickness, membrane	40 mil (1.02 mm)	ASTM D3767 method A
Tensile strength, membrane	250 psi (1720 kN/m ²)	ASTM D412 (Die C modified)
Elongation, membrane	250%	ASTM D412 (Die C modified)
Low temperature flexibility	Unaffected @ -20°F (-29°C)	ASTM D1970
Adhesion to plywood	3.0 lbs/in. width (525 N/m)	ASTM D903
Permeance (max)	0.05 Perms (2.9 ng/m ² s Pa)	ASTM E96
Material weight installed (max)	0.3 lb/ft ² (1.3 kg/m ²)	ASTM D461

www.graceresidential.com

For technical assistance call toll free at 866-333-3SBM (3726)

Grace, Grace Ice & Water Shield, Tri-Flex, Basik, Perm-A-Barrier, Vycor, Vycor Deck Protector and Ripcord are registered trademarks of W. R. Grace & Co.-Conn., registered in the United States and other countries.

Cor-Ten is a registered trademark assigned to USX Corporation.

DensGlass Gold is a registered trademark of Georgia-Pacific Corporation.

This trademark list has been compiled using available published information as of the publication date of this brochure and may not accurately reflect current trademark ownership or status. Grace Construction Products is a business segment of W. R. Grace & Co.-Conn.

We hope the information here will be helpful. It is based on data and knowledge considered to be true and accurate and is offered for the users' consideration, investigation and verification, but we do not warrant the results to be obtained. Please read all statements, recommendations or suggestions in conjunction with our conditions of sale, which apply to all goods supplied by us. No statement, recommendation or suggestion is intended for any use which would infringe any patent or copyright. W. R. Grace & Co.-Conn., 62 Whittemore Avenue, Cambridge, MA 02140. In Canada, Grace Canada, Inc., 294 Clements Road, West, Ajax, Ontario, Canada L1S 3C6.

This product may be covered by patents or patents pending.
GIWS-060X Printed in U.S.A. 02/14

Copyright 2014. W. R. Grace & Co.-Conn.
GCS/PDF

GRACE ICE & WATER SHIELD® HT

Self-adhered roofing underlayment for high temperature applications

Product Description

Grace Ice & Water Shield® HT high temperature self-adhered roofing underlayment is a premier membrane designed to deliver premium in-place performance for high temperature applications. It is composed of two waterproofing materials—an innovative and proprietary rubberized asphalt adhesive combined with a high performance polymeric film with UV barrier properties. The rubberized asphalt surface is backed with a foldless release paper that protects its adhesive quality. During application, the release paper is easily removed, allowing the rubberized asphalt to bond tightly to the roof deck. In addition, embedded in the membrane is a split release on demand feature called Ripcord®.

Features & Benefits

Today's sloped roof designs utilize more insulation, incorporate long-lasting roof coverings and tend to have lengthy construction cycles. The many variables that contribute to roof top temperatures; insulation, facing, pitch, color, etc., make it difficult to predict what kind of heat profile the roof top will experience. Choosing an underlayment that will perform under all of these demanding conditions is essential to a successful roof design.

Grace Ice & Water Shield® HT underlayment was specifically designed to meet the challenge of these high-temperature applications. It is an environmentally conscious solution that provides both confidence and design flexibility.

High temperature resistance—Rubberized asphalt will not flow, even at temperatures as high as 260°F (127°C).

Extended exposure—Can be left exposed for up to 120 days.

Superior adhesion—The self-adhered membrane bonds firmly to the roof deck without heat or special adhesives.

Ripcord is a unique, patented feature that makes Grace Ice & Water Shield® HT underlayment easier to apply by giving the applicator a split release on demand. Faster application of the membrane in the straight-aways, as well as ease of membrane positioning in detailed areas (valleys, around dormers, etc.), are just some of the benefits.

Foldless release paper—The foldless release paper provides multiple performance enhancements: fewer edge catches, 180° pull-back, ease of membrane cutting (single cuts) and membrane positioning, quicker “one-man installs” resulting in an easier, more productive release.

Seals around fasteners—The rubberized asphalt layer in Grace Ice & Water Shield® HT membrane seals around roofing nails and other fasteners, resisting leakage caused by water back-up behind ice dams or wind-driven rain.

Dual barrier protection—Rubberized asphalt is combined with

polymeric film to form two waterproofing barriers providing maximum protection.

Membrane will not crack, dry out or rot—Grace Ice & Water Shield® HT membrane resists attacks from fungus and bacteria; maintains its integrity for long lasting protection.

Protects under all standard sloped roof coverings—Grace Ice & Water Shield® HT underlayment protects under slate, tile, cedar shakes, metal and conventional asphalt shingles.

Slip resistant surface—Grace Ice & Water Shield® HT underlayment has a slip resistant embossed surface to maximize traction and improve safety.

Reroofable—Unlike some granular surfaced membranes, Grace Ice & Water Shield® HT roofing underlayment will not adhere to the underside of the exposed roof covering. It can be applied over the old Grace underlayment (except over Grace Basik®, Grace Tri-Flex® and Grace SYN 15™) in retrofit applications, making reroofing easier, less costly, more durable and environmentally friendly (as the structural deck remains intact avoiding the need to purchase additional wood decking).



Grace technical support—Grace Ice & Water Shield® HT roofing underlayment is backed by a team of local technical support personnel that help ensure every application goes smoothly.

Guidelines for Use

Grace Ice & Water Shield® HT underlayment is a waterproofing underlayment designed for use on sloped roof decks and is suitable under most traditional roof coverings, including metal and shingles for both commercial and residential applications. The Grace Ice & Water Shield® HT membrane resists water penetration due to water back-up behind ice dams or wind driven rain. It also offers leak protection in trouble prone spots like valleys, skylights, protrusions and other flashing areas.

Ice Dams

Grace Ice & Water Shield® HT membrane should be used in conjunction with designs which minimize ice dam formation. In cold climates, it is particularly important to provide proper insulation and ventilation to reduce the size of ice dams and to avoid interior condensation. Cathedral ceilings must include ventilation between rafters to allow for air flow to a ridge vent. Well ventilated cold roof designs are particularly important in alpine regions to reduce the size of ice dams which could contribute to structural damage.

Several variables will influence the height of ice dams and the membrane coverage required.

- 1. Climate**—The annual snow fall will affect the amount of membrane needed.
- 2. Slope**—On a low slope, ice dams will extend farther inward from the roof edge.
- 3. Overhang**—A wide overhang will require more membrane to reach the appropriate point on the roof.
- 4. Insulation and ventilation**—A very well insulated building with a cold, well ventilated attic will have smaller ice dams.
- 5. Valleys**—Any valleys formed by projections such as dormers or roof direction changes are likely to trap more snow and cause larger ice dams.
- 6. Exposure**—A northern exposure or shaded areas will generally contribute to larger ice dams. While gutters may make it easier for an ice dam to start, large dams can occur on roofs with no gutters.

Removing snow from a roof edge or installing heat cables may not prevent ice dam formation, but may shift the location of the ice dam. Under certain conditions, a dam can form at the edge of the remaining snow.

Local building codes should be consulted for specific requirements.

Installation Procedure

Surface Preparation

Install Grace Ice & Water Shield® HT roofing underlayment directly on a clean, dry, continuous structural deck. Some suitable deck materials include plywood, wood composition, wood plank, metal, concrete, or gypsum sheathing. Remove dust, dirt, loose nails, and old roofing materials. Protrusions from the deck area must be removed. Decks shall have no voids, damaged, or unsupported areas. Wood planks should be closely butted together. Repair deck areas before installing the membrane.

Prime concrete, masonry surfaces and DensGlass Gold® with Perm-A-Barrier® WB Primer. Prime wood composition and gypsum sheathing with Perm-A-Barrier® WB Primer if adhe-

sion is found to be marginal (*refer to Technical Letter 12, Use on Oriented Strand Board (OSB) Roof Sheathing*). Apply Perm-A-Barrier® WB Primer at a rate of 250–350 ft²/gal (6–8 m²/L). Priming is not required for other suitable surfaces provided that they are clean and dry.

Membrane Installation

Apply Grace Ice & Water Shield® HT roofing underlayment in fair weather when the air, roof deck, and membrane are at temperatures of 40°F (5°C) or higher. Apply roof covering material at temperatures of 40°F (5°C) or higher.

Cut the membrane into 10–15 ft (3–5 m) lengths and reroll loosely. Peel back 1–2 ft (300–600 mm) of release liner, align the membrane, and continue to peel the release liner from the membrane. Press the membrane in place with heavy hand pressure. Side laps must be a minimum of 3.5 in. (90 mm) and end laps a minimum of 6 in. (150 mm). For valley and ridge application, peel the release liner, center the sheet over the valley or ridge, drape, and press it in place. Work from the center of the valley or ridge outward in each direction and start at the low point and work up the roof.

Alternatively, starting with a full roll of membrane, unroll a 3–6 ft (1–2 m) piece of membrane leaving the release liner in place. Align the membrane and roll in the intended direction of membrane application. Carefully cut the release liner on top of the roll in the cross direction being careful not to cut the membrane. Peel back about 6 in. (150 mm) of the release liner in the opposite direction of the intended membrane application exposing the black adhesive. Hold the release liner with one hand and pull the roll along the deck with the release liner, leaving the applied membrane behind. Use the other hand to apply pressure on the top of the roll. Stop frequently to press the membrane in place with heavy hand pressure. When finished with the roll go back to the beginning, reroll and pull the remaining release paper from the material, finishing the installation.

For successive membrane courses, align the edge of the release liner with the dashed line provided on the surface of the membrane to achieve the 3.5 in. (90 mm) side lap.

Consistent with good roofing practice, install the membrane such that all laps shed water. Always work from the low point to the high point of the roof. Apply the membrane in valleys before the membrane is applied to the eaves. Following placement along the eaves, continue application of the membrane up the roof. The membrane may be installed either vertically or horizontally.

Use smooth shank, electro-plated galvanized nails for fastening shingles to get the best seal. Hand nailing generally provides a better seal than power-activated nailing. If nailing of the membrane is necessary on steep slopes during hot or extreme cold weather, backnail and cover the nails by overlapping with the next sheet.

Extend the membrane on the roof deck above the highest expected level of water back-up from ice dams and above the highest expected level of snow and ice on the wall sheathing on vertical side walls (dormers) and vertical front walls for ice dam protection. Consider a double layer of membrane

in critical areas, such as along the eaves or in valleys and in climates where severe ice dams are anticipated. Apply the membrane to the entire roof deck for wind-driven rain protection. Apply a new layer of Grace Ice & Water Shield® HT membrane directly over the old Grace underlayment in retrofit applications following the standard membrane application procedure.

Precautions & Limitations

- Slippery when wet or covered by frost.
- Consistent with good roofing practice, always wear fall protection when working on a roof deck.
- Release liners are slippery. Remove from work area immediately after membrane application.
- Do not leave permanently exposed to sunlight. Cover within 120 days.
- Place metal drip edges or wood starter shingles over the membrane.
- Do not fold over the roof edge unless the edge is protected by a drip edge, gutter or other flashing material.
- Do not install on the chamfered edges of wood plank.
- Do not install directly on old roof coverings.
- Certain product applications are prohibited in hot desert areas in the southwestern United States. Check with your Grace Construction Products representative.
- Check with the manufacturer of the metal roofing system for any special requirements when used under metal roofing. Do not install directly under roof coverings especially sensitive to corrosion, such as zinc, without providing proper ventilation.
- Do not install under copper, Cor-Ten®, or zinc metal roofing in high altitudes. These roofs can reach extremely high temperatures due to the low reflectivity, high absorption, and high conductivity of the metals. Use Grace Ultra™ butyl-based underlayment for these roof types. Check with your Grace Construction Products representative.
- Provide proper roof insulation and ventilation to help reduce ice dams and to minimize condensation. Grace Ice & Water Shield® HT underlayment is an air and vapor barrier.
- Repair holes, fishmouths, tears, and damage to membrane with a round patch of membrane extending past the damaged area 6 in. (150 mm) in all directions. If fasteners are removed leaving holes in the membrane, they must be patched. The membrane may not self-seal open fastener penetrations.
- Do not install fasteners through the membrane over unsupported areas of the structural deck, such as over the joints between adjacent structural panels.
- Due to its slight asphaltic odor, do not apply where the membrane is exposed to interior living space. Refer to product literature for more complete information.
- Not compatible with EPDM or TPO; use Grace Ultra® for tie-ins (*refer to Technical Letter 5, Chemical Compatibility*).
- Not compatible with polysulfides, flexible PVC, or high concentrations of resin (pitch). For more information, refer to Technical Letter 5.

Code Compliance

Grace Ice & Water Shield® HT underlayment meets all key code performance requirements for self-adhered underlayments.

- Underwriters Laboratories Inc. R13399- Class A fire classification under fiber-glass shingles and Class C under organic felt shingles (per ASTM E108/UL 790)
- Underwriters Laboratories Inc. Classified Sheathing Material

Fire Resistance

Classification with Roof Designs: P225, P227, P230, P237, P259, P508, P510, P512, P514, P701, P711, P717, P722, P723, P732, P734, P736, P742, P803, P814, P818, P824

- Meets ASTM D1970
- ICC-ES ESR-3121, per AC 48 *Acceptance Criteria for Roof Underlayments*
- Miami-Dade County Code Report NOA #11-0912.14
- Florida State Approval Report No. FL289-R3
- CCMC Approval No. 13671-L

Ice Dams

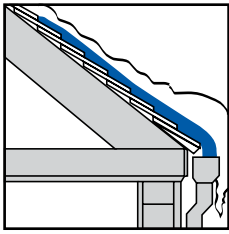

Water from melting snow over the heated portion of the house runs down the roof. It freezes at the cold eave and an ice dam begins to form preventing drainage.

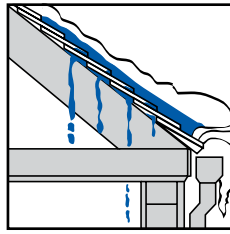

As the ice dam grows, water is trapped behind it and backs up under the shingles. Eventually it reaches the roof deck and leaks through, damaging the interior of the structure.

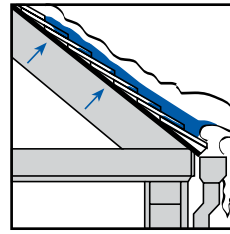

Grace Ice & Water Shield® HT membrane resists this leakage because of the seal around the fasteners, ability to make water-tight laps, and the membrane's bond to the deck.

Wind-Driven Rain

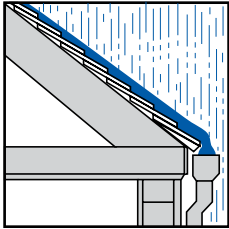

Sloped roofs are not waterproof. They protect structures by shedding rain water.

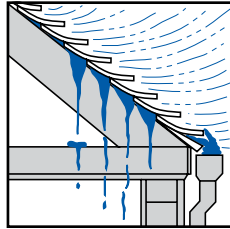

Storm-driven winds can cause sloped roof coverings to lift. Rain can then be easily driven under the roof covering directly to the unprotected roof deck where it causes leaks and damage to the interior of the structure.

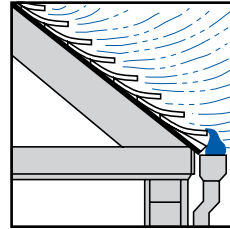

Grace Ice & Water Shield® HT membrane applied beneath the sloped roof covering helps prevent wind-driven rain from entering the structure.

Product Data

Roll length	75 ft (22.9 m)	66.6 ft (20.2 m)
Roll width	36 in. (914 mm)	36 in. (914 mm)
Roll size	225 ft ² (20.9 m ²)	200 ft ² (18.6 m ²)
Packaging	Corrugated cartons	Corrugated cartons
Roll weight	61.4 lbs (27.9 kg)	56 lbs (25.4 kg)
Rolls per pallet	35	35

Performance Properties

Property	Value	Test Method
Color	Gray-black	
Thickness, membrane	40 mil (1.02 mm)	ASTM D3767 method A
Tensile strength, membrane	MD 25 lbf/in., CD 25 lbf/in.	ASTM D412 (Die C modified)
Elongation, membrane	250%	ASTM D412 (Die C modified)
Low temperature flexibility	Unaffected @ -20°F (-29°C)	ASTM D1970
Adhesion to plywood	3.0 lbs/in. width (525 N/m)	ASTM D903
Permeance (max)	0.05 perms (2.9 ng/m ² s Pa)	ASTM E96
Material weight installed (max)	0.22 lb/ft ² (1.3 kg/m ²)	ASTM D461

www.graceresidential.com
www.graceconstruction.com

For technical assistance call toll free at 866-333-3SBM (3726)

Grace, Grace Ice & Water Shield, Ripcord, Basik and Perm-A-Barrier are trademarks of W. R. Grace & Co.—Conn. registered in the United States and other countries.

Cor-Ten is a registered trademark assigned to USX Corporation.

DensGlass Gold is a registered trademark of Georgia-Pacific Corporation.

This trademark list has been compiled using available published information as of the publication date of this brochure and may not accurately reflect current trademark ownership or status. Grace Construction Products is a business segment of W. R. Grace & Co.—Conn.

We hope the information here will be helpful. It is based on data and knowledge considered to be true and accurate and is offered for the users' consideration, investigation and verification, but we do not warrant the results to be obtained. Please read all statements, recommendations or suggestions in conjunction with our conditions of sale, which apply to all goods supplied by us. No statement, recommendation or suggestion is intended for any use which would infringe any patent or copyright. W. R. Grace & Co.—Conn., 62 Whittemore Avenue, Cambridge, MA 02140. In Canada, Grace Canada, Inc., 294 Clements Road, West, Ajax, Ontario, Canada L1S 3C6.

This product may be covered by patents or patents pending.

Copyright 204. W. R. Grace & Co.—Conn.

GIWS-210H

Printed in U.S.A.

02/14GCS/PDF

GRACE

GRACE ULTRA™

Self-adhered roofing underlayment for the highest temperature applications

Product Description

Grace Ultra™ roofing underlayment is composed of two waterproofing materials—an aggressive butyl rubber based adhesive backed by a layer of high density cross laminated polyethylene.

The product is 30 mils (0.76 mm) thick making it easy to handle and apply. The unique, advanced adhesive formulation offers premium adhesion to the roof deck, high quality laps, superior seal around roofing fasteners, and outstanding high temperature stability.

The adhesive is backed by a protective plastic release liner that protects its adhesive quality. The release liner is easily removed allowing the adhesive to be bonded tightly to the roof deck.

The membrane comes in a 198 ft² (18.4 m²) roll, and measures 34 in. (864 mm) wide.

Features & Benefits

Easy to handle and apply—The membrane bonds firmly to the roof deck and forms high quality laps.

Self sealing—The membrane meets key building code standards for nail sealability of self-adhered roofing underlayments.

Heat resistance—The membrane is specially formulated to resist temperatures up to 300°F without degradation of the butyl adhesive.

Better Chemical Resistance—Compatible with low slope roofing materials such as EPDM and TPO

Slip resistant surface—The slip resistant surface maximizes traction for safety without compromising the water integrity of the laps.

Plastic release—Plastic is easy to remove and easy to dispose of.

Reroofable—Unlike some granular surfaced membranes, Grace Ultra™ underlayment will not adhere to the underside of the exposed roof covering making reroofing easier and less costly.

Grace expertise—Grace is the recognized leader in self-adhered roofing underlayments and is the manufacturer of Grace Ice & Water Shield® roofing underlayment.

Guidelines for Use

Grace Ultra™ membrane can be used as a sloped roof underlayment to help protect against leakage from water that builds up behind ice dams, or from wind-driven rain in applications where the membrane must withstand the highest in-service temperatures for extended periods of time.

High Temperature Applications

Grace Ultra™ membrane is the appropriate product for all applications where superior heat resistance is

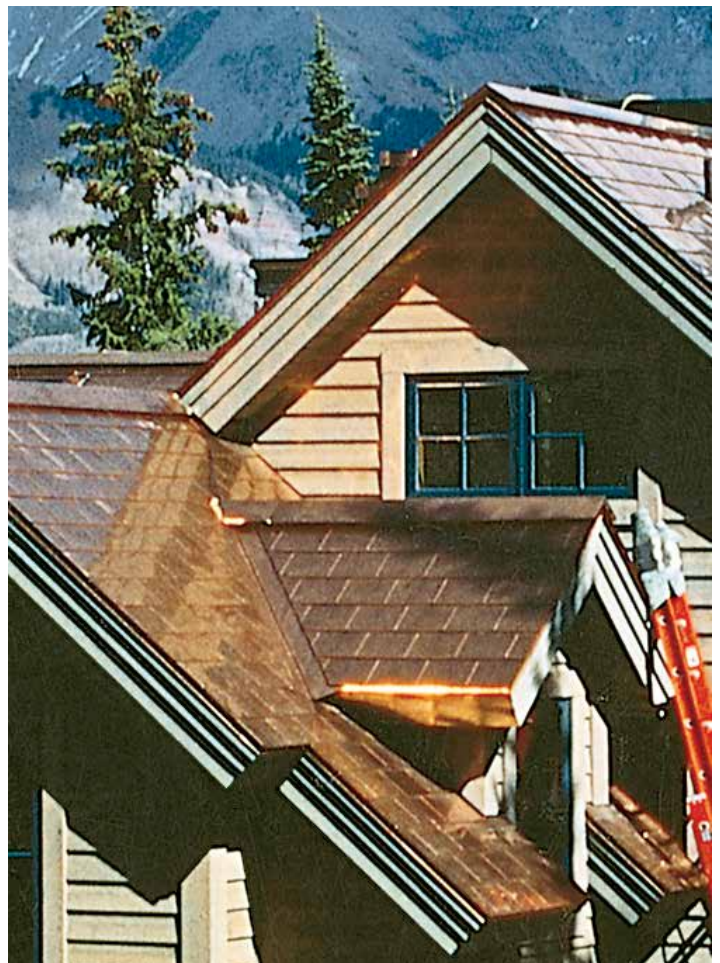

needed. In addition, Grace Ultra™ underlayment is the appropriate product for use under certain types of metal roofs (those employing copper, zinc, or Cor-Ten® panels). These metal roofs tend to readily conduct heat to the underlayment making them more likely to expose the membrane to high temperatures. It is up to the contractor and specifier to decide what level of performance is required based on the guidelines provided.

Wind-Driven Rain

Sloped roofs are not waterproof. They protect structures by shedding rain water. Storm-driven winds can cause sloped roof coverings to lift. Rain can be easily driven under the roof covering directly to the unprotected deck where it causes leaks and damage to the interior of the structure. Grace Ultra™ membrane applied beneath the sloped roof covering helps prevent wind-driven rain from entering the structure. For wind-driven rain protection, full coverage with Grace Ultra™ underlayment is recommended. Since Grace Ultra™ underlayment is a vapor barrier, the roof construction must allow for proper ventilation in full roof coverage applications.

Ice Dams

For ice dam protection, Grace Ultra™ membrane should be adhered at the edge of the roof deck by the eaves. The membrane should be applied to a point on the roof deck above the highest expected ice dam. Several variables influence the height of ice dams and the membrane coverage required. Local building codes should be consulted for specific requirements. Variables influencing the height of ice dams include climate (particularly the annual snowfall), slope, overhang, valleys, how well the structure is insulated and ventilated, and exposure (sun vs. shade). In addition to placement along the eaves, Grace Ultra™ membrane can be used to help prevent roof leaks in a handful of danger zones like in valleys, at the rake edges, and around chimneys and skylights.

Installation Procedure

Surface Preparation

Install Grace Ultra™ membrane directly on a clean, dry, continuous structural deck. Some suitable deck materials include plywood, wood composition, wood plank, metal, concrete, or gypsum sheathing. For all other substrates, contact your local Grace representative. Remove dust, dirt, loose nails, and old roofing materials. Protrusions from the deck area must be removed. Decks shall have no voids, damaged, or unsupported areas. Repair deck areas before installing the membrane.

Prime concrete, masonry surfaces and DensGlass Gold® with Perm-A-Barrier® WB Primer. Prime wood composition and gypsum sheathing with Perm-A-Barrier® WB Primer if adhesion is found to be marginal (refer to Technical Letter 12, *Use on Oriented Strand Board (OSB) Roof Sheathing*). Apply Perm-A-Barrier® WB Primer at a rate of 250–350 ft²/gal (6–8 m²/L). Priming is not required for other suitable surfaces provided that they are clean and dry.

Membrane Installation

Apply Grace Ultra™ membrane in fair weather when the air, roof deck, and membrane are at temperatures of 40°F (5°C) or higher. Apply roof covering material at temperatures of 40°F (5°C) or higher.

Cut the membrane into 10–15 ft (3–5 m) lengths and reroll loosely. Tack/secure the end of the roll with a nail. Peel back 1–2 ft (300–600 mm) of release liner, align the membrane, and continue to peel the release liner from the membrane. Press the membrane in place with heavy hand pressure. Side laps must be a minimum of 3.5 in. (90 mm) and end laps a minimum of 6 in. (150 mm). For valley and ridge application, peel the release liner, center the sheet over the valley or ridge, drape, and press it in

Use Grace Ultra™ underlayment on all of these critical areas

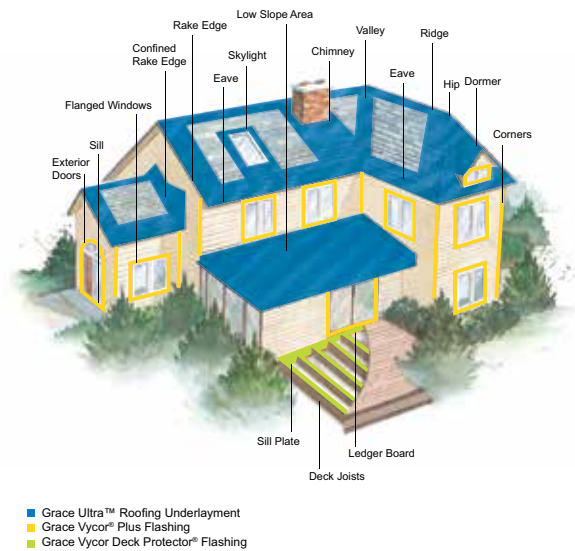

place. Work from the center of the valley or ridge outward in each direction and start at the low point and work up the roof.

Alternatively, starting with a full roll of membrane, unroll a 3–6 ft (1–2 m) piece of membrane leaving the release liner in place. Align the membrane and roll in the intended direction of membrane application. Carefully cut the release liner on top of the roll in the cross direction being careful not to cut the membrane. Peel back about 6 in. (150 mm) of the release liner in the opposite direction of the intended membrane application exposing the black adhesive. Hold the release liner with one hand and pull the roll along the deck with the release liner, leaving the applied membrane behind. Use the other hand to apply pressure on the top of the

roll. Stop frequently to press the membrane in place with heavy hand pressure. When finished with the roll go back to the beginning, reroll and pull the remaining release paper from the material, finishing the installation.

Consistent with good roofing practice, install the membrane such that all laps shed water. Always work from the low point to the high point of the roof. Apply the membrane in valleys before the membrane is applied to the eaves. Following placement along the eaves, continue application of the membrane up the roof. The membrane may be installed either vertically or horizontally.

Use smooth shank, electroplated galvanized nails for fastening shingles. Hand nailing generally provides a better seal than power-activated nailing. If nailing of the membrane is necessary on steep slopes during hot or extreme cold weather, backnail and cover the nails by overlapping with the next sheet.

Extend the membrane on the roof deck above the highest expected level of water back-up from ice dams and above the highest expected level of snow and ice on the wall sheathing on vertical side walls (dormers) and vertical front walls for ice dam protection. Consider a double layer of membrane in critical areas, such as along the eaves or in valleys and in climates where severe ice dams are anticipated. Apply the membrane to the entire roof deck for wind-driven rain protection. Apply a new layer of Grace Ultra™ underlayment directly over the old Grace underlayment in retrofit applications following the standard membrane application procedure.

Precautions & Limitations

- Slippery when wet or covered by frost.
- Consistent with good roofing practice, always wear fall protection when working on a roof deck.
- Release liners are slippery. Remove from work area immediately after membrane application.
- Do not leave permanently exposed to sunlight. Maximum recommended exposure is 60 days.
- Place metal drip edge or wood starter shingles over the membrane.
- Place metal drip edges or wood starter shingles over the membrane (refer to Technical Letter 15, *Roof Eave Application*).
- Do not fold over the roof edge unless the edge is protected by a drip edge, gutter, or other flashing material.
- Do not install on the chamfered edges of wood plank.
- Do not install directly on old roof coverings.
- Check with the manufacturer of the metal roofing system for any special requirements when used under metal roofing. Do not install directly under roof coverings especially sensitive to corrosion, such as zinc, without providing proper ventilation.
- Provide proper roof insulation and ventilation to help reduce ice dams and to minimize condensation. Grace Ultra™ underlayment is a vapor barrier.
- Repair holes, fishmouths, tears, and damage to membrane with a round patch of membrane extending past the damaged area 6 in. (150 mm) in all directions. If fasteners are removed leaving holes in the membrane, they must be patched. The membrane may not self-seal open fastener penetrations.
- Do not install fasteners through the membrane over unsupported areas of the structural deck, such as over the joints between adjacent structural panels.
- Due to its slight rubber-like odor, do not apply where the membrane is exposed to interior living space.

- Compatible with EPDMs (refer to Technical Letter 5, *Chemical Compatibility*). Also for use in tie-ins in EPDM with other Grace underlayments.
- Not compatible with polysulfides, flexible PVC or high concentrations of resin (pitch). For more information, refer to Technical Letter 5.

Standard Compliance

Grace Ultra™ meets the following standards:

- ICC ESR-1677 approval according to AC-48 Acceptance Criteria for Self-Adhered underlayments used as Ice Barriers
- Underwriters Laboratories, Inc. R13399 Class A fire classification under fiberglass shingles and Class C under organic felt shingles
- Underwriters Laboratories, Inc. Classified Sheathing Material Fire Resistance Classification Design Numbers P225, P227, P230, P237, P259, P508, P510, P512, P514, P701, P711, P717, P722, P723, P732, P734, P742, P824

Product Data

Roll length	70 ft (21.3 m)
Roll width	34 in. (864 mm)
Roll size	198 ft ² (18.4 m ²)
Packaging	Corrugated cartons
Roll weight	42 lbs (19.0 kg)
Rolls per pallet	25

Performance Properties

Property	Value	Test Method
Color	Gray-black	
Thickness, membrane	30 mil (0.76 mm)	ASTM D3767 method A
Tensile strength, membrane	250 psi (1720 kN/m ²)	ASTM D412 (Die C modified)
Elongation, membrane	250%	ASTM D412 (Die C modified)
Low temperature flexibility	Unaffected @ -20°F (-29°C)	ASTM D1970
Adhesion to plywood	3.0 lbs/in. width (525 N/m)	ASTM D903
Permeance (max)	0.05 Perms (2.9 ng/m ² s Pa)	ASTM E96
Material weight installed (max)	0.22 lb/ft ² (1.1 kg/m ²)	ASTM D461
Adhesive	Butyl based	

www.graceresidential.com

For technical assistance call toll free at 866-333-3SBM (3726)

Grace, Grace Ice & Water Shield, Perm-A-Barrier, Vycor and Vycor Deck Protector are registered trademarks of W. R. Grace & Co.-Conn. Grace Ultra is a trademark of W.R. Grace & Co.-Conn. Cor-Ten is a registered trademark assigned to USX Corporation. DensGlass Gold is a registered trademark of Georgia-Pacific Corporation.

This trademark list has been compiled using available published information as of the publication date of this brochure and may not accurately reflect current trademark ownership or status. Grace Construction Products is a business segment of W. R. Grace & Co.-Conn.

We hope the information here will be helpful. It is based on data and knowledge considered to be true and accurate and is offered for the users' consideration, investigation and verification, but we do not warrant the results to be obtained. Please read all statements, recommendations or suggestions in conjunction with our conditions of sale, which apply to all goods supplied by us. No statement, recommendation or suggestion is intended for any use which would infringe any patent or copyright. W. R. Grace & Co.-Conn., 62 Whittemore Avenue, Cambridge, MA 02140. In Canada, Grace Canada, Inc., 294 Clements Road, West, Ajax, Ontario, Canada L1S 3C6.

This product may be covered by patents or patents pending.
UL-005W Printed in U.S.A. 07/14

Copyright 2014. W. R. Grace & Co.-Conn.
GCS/PDF

GRACE

GRACE SELECT™

Self-adhered roofing underlayment

Product Description

Grace Select™ roofing underlayment is composed of two waterproofing materials—a rubberized asphalt adhesive, backed by a layer of high density cross laminated polyethylene.

The product is 25 mils (0.64 mm) thick making it lightweight and easy to handle and apply. The unique, advanced rubberized asphalt formulation allows the membrane to meet industry standards for fastener sealability equivalent to products that are often significantly thicker and heavier.

The rubberized asphalt is backed by a paper release liner that protects its adhesive quality. The release liner is easily removed allowing the rubberized asphalt to be bonded to the roof deck.

The membrane comes in a 195 ft² (18.1 m²) roll, and measures 36 in. (914 mm) wide.

Features & Benefits

Easy to handle and apply—The membrane is easy to reposition, easy to install, bonds to the roof deck and forms high quality laps.

Grace Ripcord® Split Release on Demand—The Grace Ripcord® is a nylon string that is embedded between the underlayment material and the release liner. The Ripcord® feature gives the installer the option of either splitting the release sheet for easy positioning and installation, or removing the release sheet in one piece.

Self sealing—The membrane meets key building code standards for nail sealability of self-adhered roofing underlayments.

Lightweight—The 195 ft² roll weighs only a fraction of what competitive materials weigh making transport and handling easier.

Slip resistant surface—The slip resistant surface maximizes traction for safety without compromising the water integrity of the laps. The surface film is resistant to scuffing and tracking oil in hot weather

Reroofable—Unlike some granular surfaced membranes, Grace Select™ membrane will not adhere to the underside of the exposed roof covering making reroofing easier and less costly.

Grace expertise—Grace is the recognized leader in self-adhered roofing underlayments and is the manufacturer of Grace Ice & Water Shield®.

Guidelines for Use

Grace Select™ membrane can be used as a sloped roof underlayment to resist water penetration due to wind-driven rain and ice dams. The membrane is designed to meet code based minimum standards of performance in severe climates.

Wind-Driven Rain

Sloped roofs protect structures by shedding rain water but they are not waterproof. Storm-driven winds can cause sloped roof coverings to lift. Rain can be easily driven under the roof covering directly to the unprotected deck where it causes leaks and damage to the interior of the structure. Grace Select™ membrane that is applied beneath the sloped roof covering prevents



wind-driven rain from entering the structure. For wind-driven rain protection, full coverage with the membrane is recommended. Since Grace Select™ membrane is a vapor barrier, the roof construction must allow for proper ventilation in full roof coverage applications.

Ice Dams

For ice dam protection, Grace Select™ underlayment should be adhered at the edge of the roof deck along the eaves. The product should be applied to a point on the roof deck above the highest expected ice dam. Several variables influence the height of ice dams and the membrane coverage required. Local building codes should be consulted for specific requirements. Many variables influence the height of ice dams including climate (particularly the annual snowfall), slope, overhang, valleys, how well the structure is insulated and ventilated, and exposure (sun vs. shade). In addition to placement along the eaves, the product can be used to help prevent roof leaks in a handful of danger zones including valleys, rake edges, around chimneys, and skylights.

Installation Procedure

Surface Preparation

Install Grace Select™ underlayment directly on a clean, dry, continuous structural deck. Some suitable deck materials include plywood, wood composition, wood plank, metal, concrete, or gypsum sheathing. Remove dust, dirt, loose nails, and old roofing materials. Protrusions from the deck area must be removed. Decks shall have no voids, damaged, or unsupported areas. Wood planks should be closely butted together. Repair deck areas before installing the membrane.

Prime concrete, masonry surfaces and DensGlass Gold® with Perm-A-Barrier® WB Primer. Prime wood composition and gypsum sheathing with Perm-A-Barrier® WB Primer if adhesion is found to be marginal (refer to Technical Letter 12, *Use on Oriented Strand Board (OSB) Roof Sheathing*). Apply Perm-A-Barrier® WB Primer at a rate of 250–350 ft²/gal (6–8 m²/L). Priming is not required for other suitable surfaces provided that they are clean and dry.

Membrane Installation

Apply Grace Select™ membrane in fair weather when the air, roof deck, and membrane are at temperatures of 40°F (5°C) or higher. Apply roof covering material at temperatures of 40°F (5°C) or higher.

Cut the membrane into 10–15 ft (3–5 m) lengths and reroll loosely. Peel back 1–2 ft (300–600 mm) of release liner, align the membrane, and continue to peel the release liner from the membrane. Press the membrane in place with heavy hand pressure. Side laps must be a minimum of 3.5 in. (90 mm) and end laps a minimum of 6 in. (150 mm). For valley and ridge application, peel the release liner, center the sheet over the valley or ridge, drape, and press it in place. Work from the center of the valley or ridge outward in each direction and start at the low point and work up the roof.

Alternatively, starting with a full roll of membrane, unroll a 3–6 ft (1–2 m) piece of membrane leaving the release liner in place. Align the membrane and roll in the intended direction of membrane application. Carefully cut the release liner on top of the roll in the cross direction being careful not to cut the membrane. Peel back about 6 in. (150 mm) of the release liner in the opposite direction of the intended membrane application exposing the black adhesive. Hold the release liner with one hand and pull the roll along the deck with the release liner, leaving the applied membrane behind. Use the other hand to apply pressure on the top of the roll. Stop frequently to press the membrane in

place with heavy hand pressure. When finished with the roll go back to the beginning, reroll and pull the remaining release paper from the material, finishing the installation.

Consistent with good roofing practice, install the membrane such that all laps shed water. Always work from the low point to the high point of the roof. Apply the membrane in valleys before the membrane is applied to the eaves. Following placement along the eaves, continue application of the membrane up the roof. The membrane may be installed either vertically or horizontally.

Use smooth shank, electroplated galvanized nails for fastening shingles. Hand nailing generally provides a better seal than power-activated nailing. If nailing of

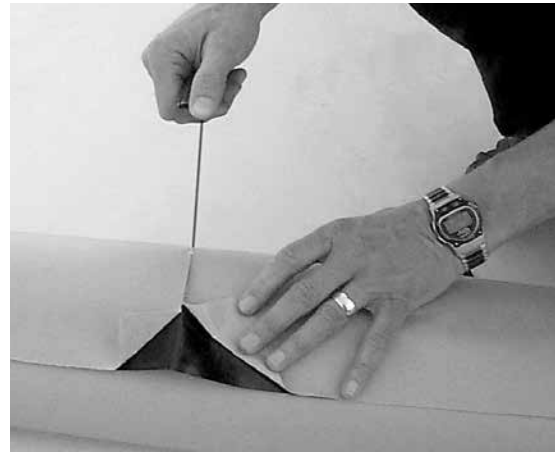

Grace Select™ roofing underlayment features the innovative Grace Ripcord™ split release on demand that is embedded between the underlayment material and the release liner. When pulled, the cord splits the release liner into two separate pieces permitting easy positioning and installation.

the membrane is necessary on steep slopes during hot or extreme cold weather, backnail and cover the nails by overlapping with the next sheet.

Extend the membrane on the roof deck above the highest expected level of water back-up from ice dams and above the highest expected level of snow and ice on the wall sheathing on vertical side walls (dormers) and vertical front walls for ice dam protection. Consider a double layer of membrane in critical areas, such as along the eaves or in valleys and in climates where severe ice dams are anticipated. Apply the membrane to the entire roof deck for wind-driven rain protection. Apply a new layer of Grace Select™ membrane directly over the old Grace underlayment (except for Grace BASIK®, Tri-Flex®, or SYN 15™) in retrofit applications following the standard membrane application procedure.

Precautions & Limitations

- Slippery when wet or covered by frost.
- Consistent with good roofing practice, always wear fall protection when working on a roof deck.
- Release liners are slippery. Remove from work area immediately after membrane application.
- Do not leave permanently exposed to sunlight. Maximum recommended exposure is 30 days.
- Place metal drip edges or wood starter shingles over the membrane.
- Do not fold over the roof edge unless the edge is protected by a drip edge, gutter, or other flashing material.
- Do not install on chamfered edges of wood plank.
- Do not install directly on old roof coverings.
For more information, refer to Technical Letter 5, *Chemical Compatibility*.
- Provide proper roof insulation and ventilation to help reduce ice dams and to minimize condensation. Grace Select is an air and vapor barrier.
- Repair holes, fishmouths, tears, and damage with a round patch of membrane extending past the damaged area 6 in. (150 mm) in all directions.
If fasteners are removed leaving holes in the membrane, they must be patched. The membrane may not self-seal open fastener penetrations.
- Do not install fasteners through the membrane over unsupported areas of the structural deck, such as over the joints between adjacent structural panels.
- Due to its slight asphaltic odor, do not apply where the membrane is exposed to interior living areas.
- Refer to product literature for more complete product information.
- Not recommended for roofing in high altitudes and alpine regions.
- Not compatible with EPDM or TPO; use Grace Ultra™ underlayment for tie-ins (refer to Technical Letter 5).
- Not compatible with polysulfides, flexible PVC, or high concentrations of resin (pitch). For more information, refer to Technical Letter 5.

Standard Compliance

Grace Select meets the following standards:

- ICC ESR-1677 approval under AC-48 Acceptance Criteria for Self-Adhered Underlayments to be used as an Ice Barrier

- Underwriters Laboratories, Inc. Class A fire classification under fiberglass shingles and Class C under organic felt shingles (per ASTM E108/UL 790).

Use Grace Select™ membrane on all of these critical areas

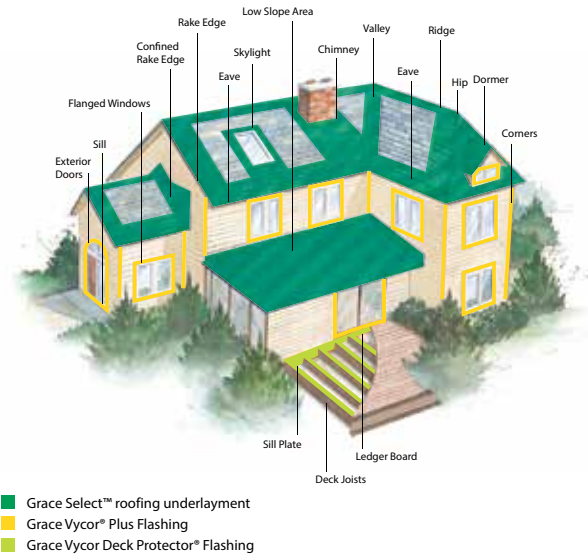

Product Data

Roll length	65 ft (19.8 m)
Roll width	36 in. (914 mm)
Roll size	195 ft ² (18.1 m ²)
Packaging	Corrugated cartons
Roll weight	32 lbs (14.5 kg)
Rolls per pallet	25

Performance Properties

Property	Value	Test Method
Color	Gray-black	
Thickness, membrane	25 mil (0.64 mm)	ASTM D3767 method A
Tensile strength, membrane	250 psi (1720 kN/m ²)	ASTM D412 (Die C modified)
Elongation, membrane	250%	ASTM D412 (Die C modified)
Adhesion to plywood	3.0 lbs/in. width (525 N/m)	ASTM D903
Permeance (max)	0.05 Perms (2.9 ng/m ² s Pa)	ASTM E96
Material weight installed (max)	0.14 lb/ft ² (0.7 kg/m ²)	ASTM D461

www.graceresidential.com

For technical assistance call toll free at 866-333-3SBM (3726)

Grace, Grace Ice & Water Shield, Tri-Flex, Basik, Perm-A-Barrier, Vycor, Vycor Deck Protector and Ripcord are registered trademarks of W. R. Grace & Co.-Conn. Grace Select, Grace Ultra, and Grace SYN 15 are trademarks of W.R. Grace & Co.-Conn. Cor-Ten is a registered trademark assigned to USX Corporation. DensGlass Gold is a registered trademark of Georgia-Pacific Corporation.

We hope the information here will be helpful. It is based on data and knowledge considered to be true and accurate and is offered for the users' consideration, investigation and verification, but we do not warrant the results to be obtained. Please read all statements, recommendations or suggestions in conjunction with our conditions of sale, which apply to all goods supplied by us. No statement, recommendation or suggestion is intended for any use which would infringe any patent or copyright. W. R. Grace & Co.-Conn., 62 Whittemore Avenue, Cambridge, MA 02140. In Canada, Grace Canada, Inc., 294 Clements Road, West, Ajax, Ontario, Canada L1S 3C6.

This product may be covered by patents or patents pending.
UL-002U Printed in U.S.A. 02/14

Copyright 2014. W. R. Grace & Co.-Conn.
GCS/PDF

GRACE

GRACE TRI-FLEX®

High performance roofing underlayment

Grace Tri-Flex® mechanically-attached roofing underlayment is a high performance water-shedding underlayment, designed to overcome the shortcomings of traditional roofing felt. It is stronger than #30 felt and withstands high wind conditions; it is lighter than #30 felt and covers more area. The product is mechanically attached to the roof and can be used alone or in conjunction with Grace self-adhered underlayments.

Grace roofing underlayment provides a stable base for the application of mechanically-attached roof coverings and serves as a secondary water shed to help prevent leaks if water penetrates the primary roof covering. The product may also be used to temporarily “dry in” the structure for a period of 6 months before the roof construction is finished or if the primary roof coverings become damaged.

Grace underlayment is suitable for application as part of all major roof systems.

Product Description

Grace underlayment is a high strength woven synthetic roofing underlayment coated with a layer of UV stabilized polyolefin. This composition creates a tough, weather-resistant membrane that has been proven under some of the harshest conditions in North America.

Grace Tri-Flex® roofing underlayment is available in 10 sq rolls (48 in. wide x 250 ft long).

Product Advantages

- Lighter and covers more area
- Stronger
- More durable
- Slip resistant under wet conditions
- Suitable for use under all major roof coverings
- Facilitates faster and easier installation
- 25 Year Warranty

Features & Benefits

Below are some of the major benefits of Grace roofing underlayment compared to conventional #30 roofing felt:

It's lighter and covers more area—A roll of underlayment is around half the weight of #30 felt, and has nearly 5 times the coverage.

It's stronger—Grace Tri-Flex® roofing underlayment is 20 times stronger than felt and won't tear away from nails even in high winds.

It's more durable—Grace underlayment can be left



exposed for up to 6 months. It doesn't dry out or rot at high temperatures. It doesn't crack or become brittle at low temperatures.

It's slip resistant—Grace roofing underlayment is formulated for excellent skid-resistance even in wet conditions.

Suitable for use under all major roof

coverings—Grace Tri-Flex® mechanically-attached underlayment can be used under shingles, tiles, slate, metal and cedar shakes. Refer to subsequent sections for more details.

Facilitates faster and easier installation—The lighter rolls make the one-person application fast and easy. It also means fewer trips up the ladder and lower labor costs.

Grace technical support—Grace Tri-Flex® underlayment is backed by a team of local technical support personnel that help ensure every application goes smoothly.

Installation Guidelines

1. The roof deck must be swept clean and be smooth and dry before installation begins.
2. Grace membrane is laid horizontally (parallel to eave), starting at the bottom of the roof, with printed side up and with 4-inch side laps and 6-inch end laps. Side laps run with the flow of water in a shingling manner.
3. Grace underlayment should not be used at slopes less than 2:12, provided the slope is also acceptable to the primary roof covering. On slopes of less than 3:12, Grace membrane should be half-lapped a full 24 inches over the underlying course, shingle style.

4. Grace Tri-Flex® underlayment is attached to the roof with roofing nails or staples both having 1-inch diameter plastic/metal caps or other fasteners approved by Grace, spaced at 8 inches on center (oc) on both side and end laps in normal wind zones. In high wind zones or coastal applications, double the fastening to 4 inches oc. In all cases fasten at 24 inches oc down the middle of the roll in the field of the roof. Capped nails and staples may be hand or machine applied. Nails or staples without caps cannot be used.
5. Where seams or joints require sealant or adhesive, use a high quality, low solvent, asbestos free plastic roofing cement meeting ASTM D4586 Type 1, Federal Spec SS-153 Type 1 (Asbestos Free). Consult your local Grace representative for more details.
6. Install drip edge at eaves under underlayment and at rake over underlayment.
7. Installation of the roof covering can proceed imme

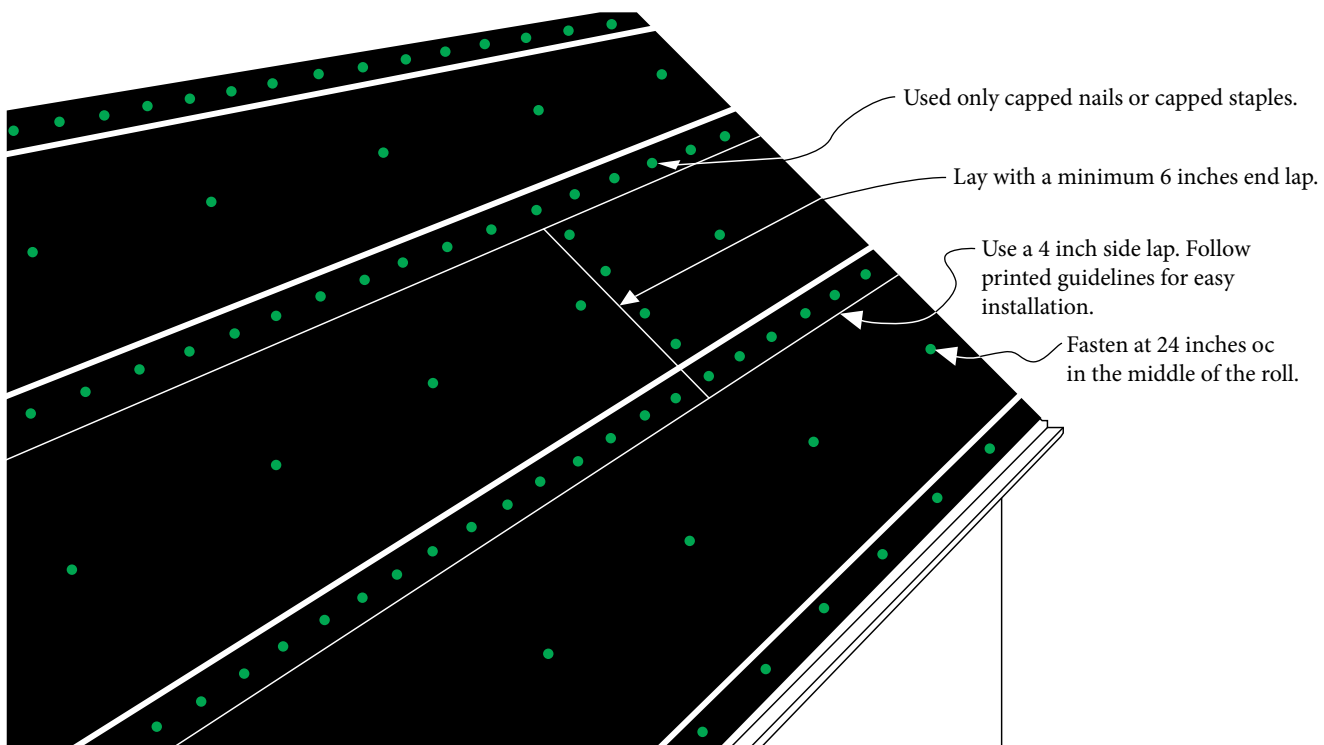

Product Data

	10 sq Roll
Roll length	250 ft (76.2 m)
Roll width	48 in (1.05 m)
Roll size	1,000 ft ² (92.9 m ²)
Roll weight	28 lbs (12.7 kg)
Rolls per pallet	30

Performance Properties

Property	Grace Tri-Flex®	Test Method
Color	Black	
Weight	28 lbs (10 sq roll)	
Tear strength	MD 58 lbs; CD 77 lbs	ASTM D4533
Accelerated aging	Pass (no damage, cracking, chipping)	ICC-ES AC48
Ultraviolet resistance	Pass (no peeling, chipping, cracking, flaking)	ICC-ES AC48
Water ponding	Pass (no percolation)	ASTM D779
Pliability	Pass (no cracks)	ASTM D226
Water transmission	Pass	ASTM D4869
Tensile strength	MD 96 lbs; CD 116 lbs	ASTM D828
Thickness	7 mils	ASTM D3767

diately following underlayment application. Grace underlayment cannot be used as a primary roof covering. The product is not designed for permanent outdoor exposure. The installation of the final roof covering should take place within 6 months.

- For additional protection lay a single length of Grace membrane vertically in valleys and on hips prior to installing metal flashings (if used) and before installing horizontal underlayment. Return Grace roofing underlayment up all abutments at least 12 inches (more in heavy snow areas). Secure and trim to suit.
- Prior to loading roofing materials on Grace underlayment it is recommended that roof jacks, toe-boards or a storage platform be secured to the underlying roof deck to prevent slippage of stored materials on steep sloped roofs. See OSHA Regulations (Standards – 29 CFR), *Fall Protection Systems Criteria and Practices* – 1926.502.
- Check local building code to ensure compliance in your area, as local building codes may vary.

Code Approvals

- ICC-ES ESR 2926
- Miami-Dade County, FL Notice of Acceptance No.11098.1
- Complies with ASTM E108/UL 790 for use in the installation of Class A asphalt glass fiber mat shingles and Class C asphalt organic felt or metal shingles
- Meets ASTM D226 physical requirements of Type I and Type II (No. 15 and No. 30 asphalt felt)

Precautions and Limitations

- Consistent with good roofing practice, always wear fall protection when working on a roof deck.
- Slippery when wet or covered by frost, debris or dust.

- Do not fold over the roof edge unless the edge is protected by a drip edge, gutter or other flashing material.
- Check with the manufacturer of the metal roofing system for any special requirements when used under metal roofing. Do not install directly under roof coverings especially sensitive to corrosion, such as zinc, without providing proper ventilation.
- Do not install under copper, Cor-Ten®, or zinc metal roofing in high altitudes or in the desert southwest. These roofs can reach extremely high temperatures due to the low reflectivity, high absorption, and high conductivity of the metals.
- Provide proper roof insulation and ventilation to help reduce ice dams and to minimize condensation.
- Repair holes, fishmouths, tears and damage to product. Grace mechanically-attached underlayment does not self-seal open fastener penetrations.
- Use nails and staples ONLY with plastic or metal caps.
- Do not install fasteners through the product over unsupported areas of the structural deck, such as over the joints between adjacent structural panels.
- Do not stretch Grace membrane during installation. The product should be pulled taut, but should not be stretched.

www.graceresidential.com

For technical assistance call toll free at 866-333-3SBM (3726)

Grace, Tri-Flex, Grace Ice & Water Shield and Basik are registered trademarks of W. R. Grace & Co.–Conn. Cor-Ten is a registered trademark assigned to USX Corporation.

This trademark list has been compiled using available published information as of the publication date of this brochure and may not accurately reflect current trademark ownership or status. Grace Construction Products is a business segment of W. R. Grace & Co.–Conn.

We hope the information here will be helpful. It is based on data and knowledge considered to be true and accurate and is offered for the users' consideration, investigation and verification, but we do not warrant the results to be obtained. Please read all statements, recommendations or suggestions in conjunction with our conditions of sale, which apply to all goods supplied by us. No statement, recommendation or suggestion is intended for any use which would infringe any patent or copyright. W. R. Grace & Co.–Conn., 62 Whittemore Avenue, Cambridge, MA 02140. In Canada, Grace Canada, Inc., 294 Clements Road, West, Ajax, Ontario, Canada L1S 3C6.

This product may be covered by patents or patents pending.
UL-146G Printed in U.S.A. 02/14

Copyright 2014. W. R. Grace & Co.–Conn.
GCS/PDF

GRACE

GRACE SYN 15™

Synthetic Replacement for #15 Felt

Grace SYN 15™ synthetic underlayment exceeds the requirements of ASTM D226 and offers the benefits of a synthetic to traditional #15 felt users. Its higher coverage per roll means it goes down quickly. Because it is 10x stronger than #15 felt, costly blow offs are prevented. The product is mechanically fastened, and may be used in conjunction with GRACE self adhered underlayments, or alone.

It is totally recyclable, and contains post industrial recycled polymers, so it contributes to sustainability and LEED.

Grace SYN 15™ underlayment acts as a secondary watershedding material below mechanically attached roof coverings. The product may be exposed for up to 30 days, and may be used with asphalt shingles and most other roof coverings.

Product Description

Grace SYN 15™ underlayment is an engineered woven fabric, coated on both sides with polypropylene. The proprietary resin formula used in the walk and deckside surfaces create a slip resistant surface.

Grace SYN 15™ underlayment is available in 10 sq rolls (48 in. wide x 250 ft long).

Features & Benefits

Major benefits of Grace SYN 15™ underlayment vs #15 felt include:

Product Advantages vs. #15 Felt

- Stronger
- More slip resistant
- Better Coverage per roll, greater productivity
- Suitable for use under all major roof coverings
- 10 Year Warranty

Stronger—Its 10x stronger and prevents blow offs and tears in windy conditions

Higher Coverage per Roll—A 10 sq roll is 67% lighter than #15 felt, and covers 2.3 times the area

Fewer Laps and Fasteners—30% more coverage per side lap than felt

Sustainable—Grace SYN 15™ underlayment is 100% recyclable, and contains post industrial recycled materials, and contributes to sustainability and LEED

Excellent temporary dry in—May be exposed for up to 30 days



Suitable for use under asphalt shingles and most other major roof coverings

Grace technical support—Grace SYN 15™ underlayment is backed by a team of local technical support personnel that help ensure every application goes smoothly.

Installation Guidelines

1. The roof deck must be swept clean and be smooth and dry before installation begins.
2. Grace SYN 15™ underlayment is laid horizontally (parallel to eave), starting at the bottom of the roof, with printed side up and with 4-inch side laps and 6-inch end laps. Side laps run with the flow of water in a shingling manner.
3. Grace SYN 15™ underlayment should not be used at slopes less than 2:12, provided the slope is also acceptable to the primary roof covering. On slopes of less than 3:12, Grace SYN 15™ underlayment should be half-lapped a full 24 inches over the underlying course, shingle style.
4. Grace SYN 15™ underlayment is attached to the roof with roofing nails or staples both having 1-inch diameter plastic/metal caps or other fasteners approved by Grace, spaced at 8 inches on center (oc) on both side and end laps in normal wind zones. In high wind zones or coastal applications, double the fastening to 4 inches oc. In all cases fasten at 24 inches oc down the middle of the roll in the field of the roof. Capped nails and staples may be hand or machine applied. Nails or staples without caps cannot be used.
5. Where seams or joints require sealant or adhesive, use a high quality, low solvent, asbestos free plastic roofing cement meeting ASTM D4586 Type 1, Federal Spec SS-153 Type I (Asbestos Free).

Consult your local Grace representative for more details.

6. Install drip edge at eaves under underlayment and at rake over underlayment.
7. Installation of the roof covering can proceed immediately following underlayment application. Grace SYN 15™ underlayment cannot be used as a primary roof covering. The product is not designed for permanent outdoor exposure. The installation of the final roof covering should take place within 30 days.
8. For additional protection lay a single length of Grace SYN 15™ underlayment vertically in valleys and on hips prior to installing metal flashings (if used) and before installing horizontal underlayment. Return Grace SYN 15™ underlayment up all abutments at least 12 inches (more in heavy snow areas). Secure and trim to suit.
9. Prior to loading roofing materials on Grace SYN 15™ underlayment it is recommended that roof jacks, toe-boards or a storage platform be secured to the underlying roof deck to prevent slippage of stored materials on steep sloped roofs. See OSHA Regulations (Standards – 29

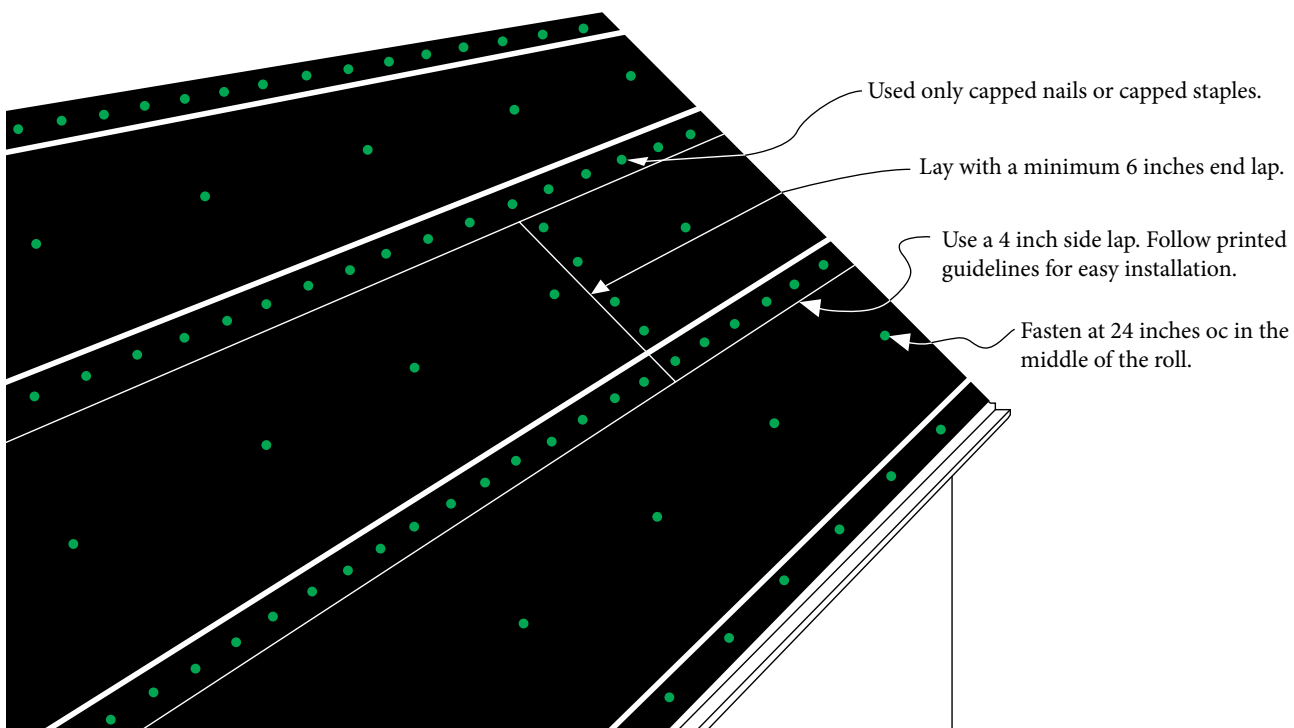

Product Data

	10 sq Roll
Roll length	250 ft (76.2 m)
Roll width	48 in (1.05 m)
Roll size	1,000 ft ² (92.9 m ²)
Roll weight	20 lbs (9.1 kg)
Rolls per pallet	35

Performance Properties

Property	Grace SYN 15™	Test Method
Color	Black	
Weight	20 lbs (10 sq roll)	
Tear strength	MD 36 lbs; CD 36 lbs	ASTM D4533
Accelerated aging	Pass (no damage, cracking, chipping)	ICC-ES AC48
Ultraviolet resistance	Pass (no peeling, chipping, cracking, flaking)	ICC-ES AC48
Water ponding	Pass (no percolation)	ASTM D779
Pliability	Pass (no cracks)	ASTM D226
Water transmission	Pass	ASTM D4869
Tensile strength	MD 66 lbs; CD 49 lbs	ASTM D828
Thickness	7 mils	ASTM D3767

CFR), *Fall Protection Systems Criteria and Practices* – 1926.502.

10. Check local building code to ensure compliance in your area, as local building codes may vary.

Code Approvals

- Complies with AC-188 Acceptance Criteria for Roof Underlayments ICC ESR-3509.
- Meets the requirements of Florida Building Code, Approval #FL16038.1-R0
- Complies with ASTM E108/UL 790 for use in the installation of Class A asphalt glass fiber mat shingles and Class C asphalt organic felt or metal shingles
- Meets ASTM D226 physical requirements of Type I and Type II (No. 15 asphalt felt)

Precautions and Limitations

- Consistent with good roofing practice, always wear

fall protection when working on a roof deck.

- Slippery when wet or covered by frost, debris or dust.
- Do not fold over the roof edge unless the edge is protected by a drip edge, gutter or other flashing material.
- Check with the manufacturer of the metal roofing system for any special requirements when used under metal roofing. Do not install directly under roof coverings especially sensitive to corrosion, such as zinc, without providing proper ventilation.

- Do not install under copper, Cor-Ten®, or zinc metal roofing in high altitudes or in the desert southwest. These roofs can reach extremely high temperatures due to the low reflectivity, high absorption, and high conductivity of the metals.
- Provide proper roof insulation and ventilation to help reduce ice dams and to minimize condensation.
- Repair holes, fishmouths, tears and damage to product. Grace SYN 15™ underlayment does not self-seal open fastener penetrations.
- Use nails and staples ONLY with plastic or metal caps.
- Do not install fasteners through the product over unsupported areas of the structural deck, such as over the joints between adjacent structural panels.
- Do not stretch Grace SYN 15™ underlayment during installation. The product should be pulled taut, but should not be stretched.

www.graceresidential.com
www.graceconstruction.com

For technical assistance call toll free at 866-333-3SBM (3726)

Grace SYN 15 is a trademark of W.R. Grace & Co.-Conn. Cor-Ten is a registered trademark assigned to USX Corporation.

This trademark list has been compiled using available published information as of the publication date of this brochure and may not accurately reflect current trademark ownership or status. Grace Construction Products is a business segment of W. R. Grace & Co.-Conn.

We hope the information here will be helpful. It is based on data and knowledge considered to be true and accurate and is offered for the users' consideration, investigation and verification, but we do not warrant the results to be obtained. Please read all statements, recommendations or suggestions in conjunction with our conditions of sale, which apply to all goods supplied by us. No statement, recommendation or suggestion is intended for any use which would infringe any patent or copyright. W. R. Grace & Co.-Conn., 62 Whittemore Avenue, Cambridge, MA 02140. In Canada, Grace Canada, Inc., 294 Clements Road, West, Ajax, Ontario, Canada L1S 3C6.

This product may be covered by patents or patents pending.
 UL-166C Printed in U.S.A. 02/14

Copyright 2014. W. R. Grace & Co.-Conn.
 GCS/PDF

GRACE

GRACE ROOF DETAIL MEMBRANE

Self-adhered flexible flashing

Premium Protection at Roof Detail Areas

Roof details, such as valleys, rake edges, chimneys, ridges, skylights and dormer walls, can greatly enhance the beauty of any home. Unfortunately, they are also some of the most leak-prone areas on a roof.

The results can range from stained walls and ceilings to severe water damage, costing thousands of dollars to repair. Unless the leakage problem is corrected, damage will continue to result.

Granular underlayments may lack the ability to conform to many common roof details, creating the potential for leaks. Grace Roof Detail Membrane is a flexible product that conforms tightly to these transition areas, reducing the risk of water infiltration.

Grace Roof Detail Membrane is the only product available today designed specifically for waterproofing critical roof detail areas.

Product Description

Grace Roof Detail Membrane is a premier membrane based on the Grace Ice & Water Shield® roofing underlayment technology. The new membrane has the Ripcord® split-release on demand feature placed in the center and near the edge (18 in. width) for easy installation at the transition areas as well as allowing for

future tie-ins. The membrane also features square edge cuts and measure markings on the face to further simplify layout and installation. The membrane is composed of two waterproofing materials—an aggressive rubberized asphalt adhesive backed by a layer of high-density, cross-laminated polyethylene. The rubberized asphalt surface is backed with a release paper that protects its adhesive quality. During application, the release paper is easily removed, allowing the rubberized asphalt to bond tightly to the roof deck and walls.

The membrane is available in 9 in. and 18 in. widths. See the Product Data chart for more information.



Product Advantages

- Easy to handle and apply
- Seals around nails
- Membrane will not crack, dry out or rot
- Protects under all standard sloped roof coverings
- Slip resistant surface
- Proven track record
- Reroofable
- Inhibits corrosion
- Grace technical support

Features & Benefits

Easy to handle and apply—The self-adhesive membrane bonds firmly to the substrate without heat or special adhesives. Water cannot seep under the membrane. Watertight seams are easily formed.

Ripcord® split-release on demand is a unique, patented feature that makes Grace Roof Detail Membrane easy to apply by giving the applicator a split release on demand. The split release makes positioning in detail areas easy by minimizing the amount of adhesive exposed during installation. Both the 9 in. and 18 in. rolls contain Ripcord® split-release on demand placed at the center and near the edges to simplify application of the membrane at angled transitions, allowing the applicator to select the amount of adhesive to be exposed during installation.

Seals around nails—The rubberized asphalt layer in Grace Roof Detail Membrane seals around roofing nails, resisting leakage caused by water back-up behind ice dams, or from wind-driven rain.

Membrane will not crack, dry out or rot—Grace Roof Detail Membrane resists attacks from fungus and bacteria; maintains its integrity for long lasting protection.

Protects under all standard sloped roof coverings—Grace Roof Detail Membrane protects under slate, tile, cedar shakes or metal, as well as under conventional asphalt shingles.

Slip resistant surface—Grace Roof Detail Membrane has a slip resistant embossed surface to maximize traction and safety for applicators.

Proven track record—Grace Roof Detail Membrane is based on Grace Ice & Water Shield® underlayment, the name brand in roofing underlayments with over 30 years of protecting roofs from ice dams and wind-driven rain.

Reroofable—Unlike some granular-surfaced membranes, Grace Roof Detail Membrane will not adhere to the underside of the exposed roof covering. Grace Roof Detail Membrane can be applied over the old Grace underlayment (except over Grace Basik® underlayment) in retrofit applications, making reroofing easier, less costly—since there is no need for removing the existing underlayment—more durable and environmentally friendly—as the substrate remains intact, avoiding the need to purchase additional wood substrate.

Inhibits corrosion—Grace Roof Detail Membrane isolates metal roof components from new corrosive wood preservatives.

Grace technical support—Grace Roof Detail Membrane is backed by a team of technical support personnel that help ensure every application goes smoothly.

Guidelines for Use

Roof Details—Grace Roof Detail Membrane is used as a flashing to provide resistance against water infiltration at trouble-prone roof detail areas such as valleys, drip edges, rake edges, chimneys, ridges, skylights, dormer walls and roof-to-wall transitions.

Local building codes should be consulted for specific requirements.

Installation Procedure

Surface Preparation

Install Grace Roof Detail Membrane directly on a clean, dry, continuous structural substrate. Some suitable substrates are plywood, wood composition, metal, concrete or gypsum sheathing. For all other substrates, contact your Grace representative. Remove dust, dirt, loose nails and old roofing materials. Protrusions from the substrate area must be removed. Substrates shall have no damaged or unsupported areas, or voids. Repair substrate before installing the membrane.

Use Grace Roof Detail Membrane on all critical areas

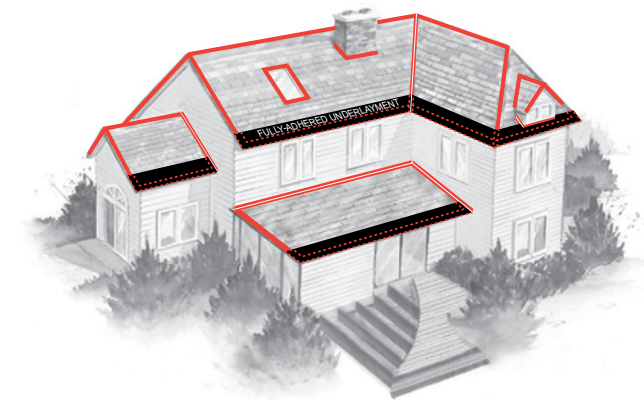

■ Grace Roof Detail Membrane

Priming

Prime concrete, masonry, DensGlass Gold® and DensDeck® surfaces with Perm-A-Barrier® WB Primer. Prime wood composition and gypsum sheathing with Perm-A-Barrier® WB Primer if adhesion is found to be marginal (refer to Technical Letter 12, *Use on Oriented Strand Board (OSB) Roof Sheathing*). Apply Perm-A-Barrier® WB Primer at a rate of 250–350 ft²/gal (6–8 m²/L). Priming is not required for other suitable surfaces provided that they are clean and dry.

Grace Roof Detail Membrane Installation with Ripcord® Split Release Feature

Apply Grace Roof Detail Membrane only in fair weather when the air, substrate and membrane are at temperatures of 40°F (5°C) or higher. Apply roof and wall covering at membrane temperatures of 40°F (5°C)

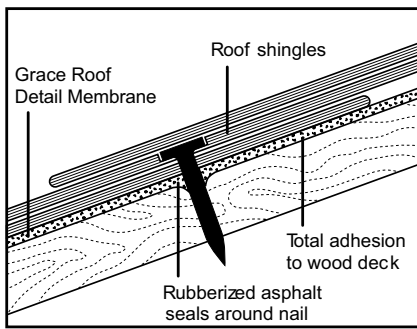

Seals around nails or fasteners. Fully adheres to decks, resisting leaks from wind-driven rain or water backup due to ice dams.

or higher.

1. Cut membrane to length.
2. Locate and pull Ripcord® line, splitting release liner. Place membrane in position.
3. Remove half of the release liner, exposing part of the membrane.
4. Press the exposed portion of the membrane into place with heavy hand pressure, smoothing outward toward the edge.
5. Remove remaining portion of the release liner and press remaining membrane into place, using the same procedure. The remaining portion of release liner may be left in place to allow for future tie-ins. Refer to the Grace Ice & Water Shield® roofing underlayment Contractor's Guide or the web site (www.graceconstruction.com) for specific detail drawings.

Consistent with good roofing practice, install the membrane such that all laps shed water. Always work from the low point to the high point of the roof.

Precaution & Limitations

- Slippery when wet or covered by frost.
- Consistent with good roofing practice, always wear fall protection when working on a roof deck.
- Release liners are slippery. Remove from work area immediately after membrane application.
- Do not leave permanently exposed to sunlight. Cover within 30 days.
- Do not fold over the roof edge unless the edge is protected by a drip edge, gutter or other flashing material.
- Do not install on chamfered edges of wood plank.
- When lapping over granular, allow for 6 in. overlap and apply bead of roofing mastic along the edge of the Grace Roof Detail Membrane.
- Repair holes, fishmouths, tears and damage with a round patch of membrane, extending past the damaged area 6 in. (150 mm) in all directions.
If fasteners are removed leaving holes in the membrane, it must be patched. The membrane may not self-seal open fastener penetrations.
- Do not install fasteners through the membrane over unsupported membrane areas of the structural deck, such as over the joints between adjacent structural panels.
- Due to its slight asphaltic odor, do not apply where membrane is exposed to interior living spaces. Refer to product literature for more complete information.
- Not compatible with EPDM or TPO; use Grace Ultra™ roofing underlayment for tie-ins (refer to Technical Letter 5, *Chemical Compatibility*).

- Not compatible with polysulfides, uncured neoprene, wood substrates with high concentrations of resin (pitch), or flexible PVC. Grace Roof Detail Membrane is generally compatible with window and skylight flanges; for more information, refer to Technical Letter 5.
- Do not use in the desert southwest U.S.
- Do not use under copper, Cor-Ten® or zinc metal roofs in high altitudes.
- A minimum of 36 in. is recommended at the eaves, where ice dams may form. Grace recommends Grace Ice & Water Shield® roofing underlayment for this application. Grace Roof Detail Membrane may be used in conjunction with a self-adhered underlayment to extend ice dam protection at the eaves.

Code Compliance

Grace Roof Detail Membrane meets the following standards:

- Underwriters Laboratories Inc. Class A fire classification under fiber-glass shingles and Class C under organic felt shingles (per ASTM E108/UL 790)
- International Conference of Building Officials (ICBO-ES) Report No. 3997
- Southern Building Code Congress International (SBCCI PST & ESI) Report No. 94133C
- Building Officials and Code Administrators (BOCA-ES) Evaluation Report No. 94-33
- Miami-Dade County NOA 09-0107.08.
- City of Los Angeles RR 25330

Product Data **18 in. width** **9 in. width**

Roll length	50 ft (15.2 m)	50 ft (15.2 m)
Roll width	18 in. (457 mm)	9 in. (229 mm)
Roll size	75 ft ² (7.0 m ²)	37.5 ft ² (3.5 m ²)
Ripcord	• One at center (9 in. from edge) • Two near edge (4.5 in. from edge)	• One at center (4.5 in. from edge)
Packaging	Corrugated carton	Six individually labeled rolls in corrugated carton
Roll weight	19 lbs (8.6 kg)	9.5 lbs (4.3 kg)
Rolls per carton	One (1)	Six (6)
Cartons per pallet	50	30

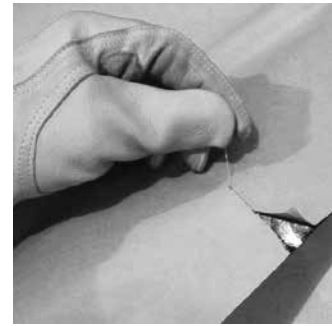

Performance Properties

Property	Value	Test Method
Color	Gray-black	
Thickness, membrane	40 mil (1.02 mm)	ASTM D3767 method A
Tensile strength, membrane	250 psi (1720 kN/m ²)	ASTM D412 (Die C modified)
Elongation, membrane	250%	ASTM D412 (Die C modified)
Low temperature flexibility	Unaffected @ -20°F (-29°C)	ASTM D1970
Adhesion to plywood	3.0 lbs/in. width (525 N/m)	ASTM D903
Permeance (max)	0.05 Perms (2.9 ng/m ² s Pa)	ASTM E96
Material weight installed (max)	0.3 lb/ft ² (1.3 kg/m ²)	ASTM D461

Grace Roof Detail Membrane is suitable for use in the same roofing environments as Grace Ice & Water Shield®, Grace Select™, Grace Basik® and Grace Tri-Flex® (except in the desert southwest U.S.). Please see the chart below for more details.

Grace Underlayments Product Selection Matrix

Water-Shedding Membrane

Application Guidelines	Grace Ultra™	Grace Ice & Water Shield®	Grace Select™	Grace Basik®	Grace Tri-Flex®
Desert southwest United States	●	⊗	⊗	○*	●
Under copper, zinc or Cor-Ten® in high altitude climates	●	⊗	⊗	⊗	⊗
Under architectural metal roofs	●	●	○	⊗	●
Roofing in high altitude/alpine regions	●	●	⊗	⊗	○
Premium protection from severe ice dams	●	●	⊗	⊗	⊗
As a vapor barrier	●	●	●	○	○

Note: When interpreting the above chart, consider that all Grace self-adhered underlayments, including Grace Ice & Water Shield®, Grace Ultra™, Grace Select™ and Grace Basik®, are *waterproofing membranes*, while Grace Tri-Flex® provides a premium *water-shedding* roof protection.

* For application on wood substrates only

● Best ○ Good ⊗ Not Recommended

www.graceresidential.com

For technical assistance call toll free at 866-333-3SBM (3726)

Grace, Ice & Water Shield, Tri-Flex, Basik, Perm-A-Barrier and Ripcord are registered trademarks and Vycorner is a trademark of W. R. Grace & Co.–Conn. Cor-Ten is a registered trademark assigned to USX Corporation. DensGlass Gold and DensDeck are registered trademarks of Georgia-Pacific Corporation.

We hope the information here will be helpful. It is based on data and knowledge considered to be true and accurate and is offered for the users' consideration, investigation and verification, but we do not warrant the results to be obtained. Please read all statements, recommendations or suggestions in conjunction with our conditions of sale, which apply to all goods supplied by us. No statement, recommendation or suggestion is intended for any use which would infringe any patent or copyright. W. R. Grace & Co.–Conn., 62 Whittemore Avenue, Cambridge, MA 02140. In Canada, Grace Canada, Inc., 294 Clements Road, West, Ajax, Ontario, Canada L1S 3C6.

This product may be covered by patents or patents pending.
GIWS-196E Printed in U.S.A. 02/14

Copyright 2014. W. R. Grace & Co.–Conn.
GCS/PDF



Vycor® enV-S™

Fully-adhered weather resistive barrier sheet

Description

Vycor® enV-S™ sheet applied, vapor permeable weather resistive barrier consists of a unique breathable carrier film coated with an adhesive that is specially designed to maintain vapor permeability.

Keeping walls dry is the key to preventing rot of structural elements and mold growth. Vycor® enV-S™ fully-adhered barrier protects against wind driven rain. Vycor® enV-S™ vapor permeable membrane allows the wall system to “breathe”, and water vapor to escape.

Unlike conventional building wraps, installation of Vycor® enV-S™ weather resistive barrier requires no mechanical fastening, and it seals around nails used to install siding and other wall elements. This results in exceptionally low levels of air leakage, and improved energy efficiency of the building.

Advantages

- **Fully-adhered**—installation requires no mechanical fasteners or taping of seams
- **Water resistive**—forms a fully adhered barrier against wind driven rain
- **Vapor permeable**—“breathable” membrane prevents moisture from becoming trapped in the wall cavity and provides walls the ability to dry
- **Air resistive**—greatly reduces air leakage and helps improve building energy efficiency

- **Strong adhesion**—to unprimed plywood and oriented strand-board (OSB).
- **Controlled thickness**—factory made sheet ensures consistent, non-variable site application
- **Lightweight**—allows for easy handling and installation
- **Installation flexibility**—may be exposed up to 90 days
- **System solution**—when used in combination with Grace Vycor® Flashings

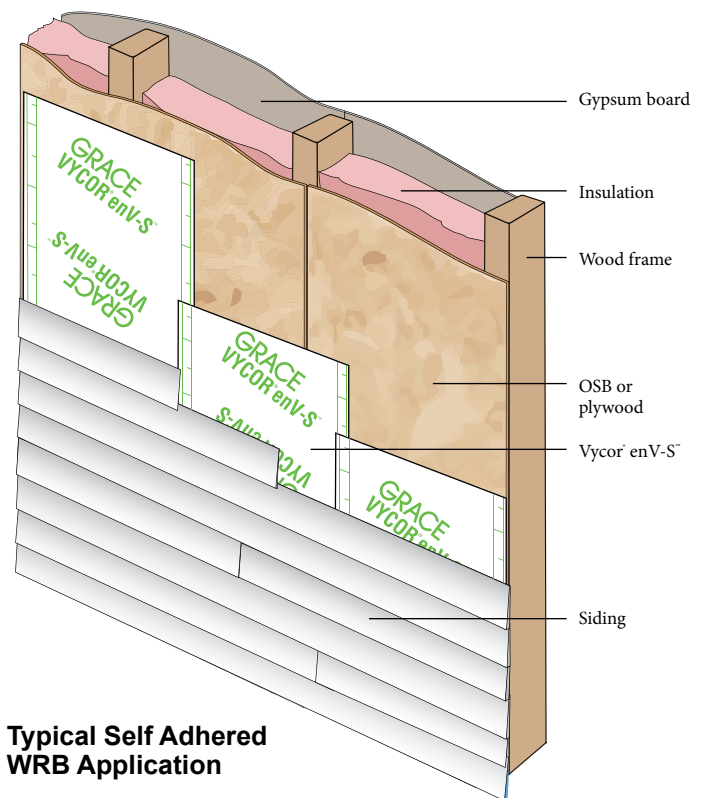

Typical Self Adhered WRB Application

Drawings are for illustration purposes only. Please refer to graceconstruction.com for specific application details.

Product Advantages

- Self-adhered sheet
- Water resistive
- Vapor permeable
- Air resistive
- Easy to install
- Improves energy efficiency
- Seals around nails
- Strong adhesion to wood substrates

Principal Applications

Vycor® enV-S™ water and air resistive barrier can be used for new and remedial residential construction applications. It is installed onto exterior wall substrates and behind the exterior siding or cladding.

System Components

- **Vycor® enV-S™ Weather Resistive Barrier**—for use on above-grade walls at installation temperatures above 40°F (5°C)
- **Vycor® Plus**—heavy duty rubberized asphalt based membrane for flashing around windows and doors
- **Perm-A-Barrier® Primer Plus**—waterbased vapor permeable primer used when adhesion appears to be marginal.
- **Sealants** — refer to Technical Letter 1 for details on compatible waterproofing sealants

Installation

Safety

Refer to product label and Material Safety Data Sheet before use. All users should acquaint themselves with this information prior to working with the material. Carefully read detailed precaution statements on the product labels and MSDS before use. MSDSs can be obtained from our web site at graceconstruction.com, graceresidential.com or by contacting Grace toll free at 866-333-3SBM (3726).

Temperature

Vycor® enV-S™ weather resistive barrier may be applied only in dry weather when air and surface temperatures are above 40°F (5°C).

Surface Preparation

Vycor® enV-S™ weather resistive barrier can typically be installed over clean and dry wood sheathing (plywood or OSB) without the aid of an adhesive primer. In those cases when adhesion appears to be marginal, or when installing over cementitious or glass-mat faced substrates, use Grace Perm-A-Barrier® Primer Plus to aid in creation of a tenacious bond to the substrate.

Apply Perm-A-Barrier® Primer Plus by brush or roller application. Allow Perm-A-Barrier® Primer Plus to dry until surface becomes tacky. Drying times may vary depending on temperature and humidity conditions. Refer to Perm-A-Barrier® Primer Plus product data sheet for installation recommendations.

Surface must be smooth, clean, dry and free of voids, loose nails, sharp protrusions or other matter that will hinder the adhesion or regularity of the wall membrane installation. Clean loose dust or dirt from the surface to which the wall membrane is to be applied by wiping with a clean, dry cloth or brush. OSB and plywood must have moisture content below 12%.

Membrane Application

Cut membrane into easily handled lengths. Apply membrane horizontally or vertically to plywood or OSB substrates. All side and end laps must be overlapped a minimum of 2 in. (51 mm) and all laps must be water-shedding

The membrane must be pressed firmly into place with a hand roller as soon as possible, ensuring continuous and intimate

contact with the substrate to prevent water from migrating under the membrane.

Continue the membrane into all openings in the wall area, such as windows, doors, etc., and terminate at points that will prevent interior visibility. The installation must be made continuous at all framed openings, such as windows, doors, etc. Flash framed openings with Vycor® Plus Flashing and overlap onto Vycor® enV-S™ membrane in a shingled manner. Coordinate installation of the Vycor® enV-S™ membrane with the roofing trade to ensure continuity with the roofing system at this critical transition area.

In certain applications such as on soffits or ceilings, back nail the membrane along the

side lap prior to installing the next sheet of membrane to ensure positive contact to

the substrate.

At the end of each working day, if the wall has been only partially covered, apply a bead of compatible sealant along the top edge of the membrane at its termination to prevent vertical drainage of precipitation from penetrating the end and undermining the membrane adhesion. Tool the compatible sealant to ensure it is worked into the surface.

Inspect the membrane before covering and repair any punctures, damaged areas or inadequately lapped seams.

Membrane Repairs

Repairs must be made using Vycor® enV-S™ barrier sized to extend 6 in. (150 mm) in all directions from the perimeter of the affected area. If repairs are required, carefully cut out affected areas and replace in similar procedure as outlined in the text above. The repair piece must be pressed into place with a hand roller as soon as possible to ensure continuous and intimate contact with the substrate. Apply a bead of compatible sealant along the top edge of the repair piece.

Membrane Protection

Vycor® enV-S™ weather resistive barrier must be protected from damage by other trades or construction materials.

Storage and Handling Information

All materials must be protected from rain and physical damage. Pallets of Vycor® enV-S™ weather resistive barrier must not be double stacked on the job site. Provide cover on top and all sides, allowing for adequate ventilation. Store membrane where temperatures will not exceed 90°F (32°C) for extended periods. All products must be stored in a dry area away from high heat, flames or sparks. Store only as much material at point of use as is required for each day's work.

Supply

Product	Unit of Sale	Approximate Coverage	Weight	Palletization
Vycor® enV-S™ Weather Resistive Barrier	1 roll	450 ft ² (41.8 m ²) per roll 40 in x 135 ft (1.02m x 41.1m)	28.7 lbs/roll	36 cartons (36 rolls) per pallet
Perm-A-Barrier® Primer Plus-5 gal pail	1 pail	450-500 ft ² /gal (11-12 m ² /L)	43 lbs/pail	36 pails per pallet

Typical Performance Properties

Test	Typical Value	Method
Color	White with Green Logo	
Air permeance at test pressure of 1.57 psf (75 Pa)	<0.0004 cfm/ft ² 2 1.57 pcf) (0.002 l/m ² @ 75Pa	ASTM E2178
Water vapor permeance	15 perms	ASTM E96
Water resistance	Pass	AATCC-127 Hydrostatic Head Per ICC-ES AC-38
Peel strength @ 70°F	4 pli to unprimed plywood 3pli to Vycor enV-S	AAMA 711/ASTM D 3330
Breaking force	54 lbs, Machine Direction 46 lbs, Cross Direction	ASTM D5034
Low Temperature flexibility	Pass	ICC – AC38
Water penetration resistance around nails Tested per AAMA 711-07 Procedure	Pass	ASTM D1970
Surface Burning Characteristics	Class A - Flame spread index of 5 Smoke developed index of 15	ASTM E84

Limitations

Vycor® enV-S™ weather resistive barrier must not be applied in areas where it will be permanently exposed to UV light and must be covered within a reasonable amount of time, not to exceed 90 days.

Technical Service

Support is provided by full-time technically trained Grace field sales representatives and technical service personnel, backed by a central research and development technical services staff.

Codes and Approvals

Meets the requirements and standards as set forth in AC-38 (Acceptance Criteria for Water Resistive Barriers) as a Water Resistive Barrier and Air Barrier. Approval pending.

www.graceresidential.com

For technical assistance call toll free at 866-333-3SBM (3726)

Vycor[®], Vycor enV[®], and Perm-A-Barrier[®] are trademarks, registered in the United States and/or other countries, of W. R. Grace & Co.-Conn. This trademark list has been compiled using available published information as of the publication date of this brochure and may not accurately reflect current trademark ownership or status. Grace Construction Products is a business segment of W. R. Grace & Co.-Conn. © Copyright 2014 W. R. Grace & Co.-Conn. All rights reserved.

We hope the information here will be helpful. It is based on data and knowledge considered to be true and accurate and is offered for the users' consideration, investigation and verification, but we do not warrant the results to be obtained. Please read all statements, recommendations or suggestions in conjunction with our conditions of sale, which apply to all goods supplied by us. No statement, recommendation or suggestion is intended for any use which would infringe any patent or copyright. W. R. Grace & Co.-Conn., 62 Whittemore Avenue, Cambridge, MA 02140.

In Canada, Grace Canada, Inc., 294 Clements Road, West, Ajax, Ontario, Canada L1S 3C6.

This product is protected by U.S. Patent 8,277,915. Copyright 2014. W. R. Grace & Co.-Conn.
WRB-009E Printed in U.S.A. 09/14 GCS/PDF

GRACE

Vycor enV®

Fully-adhered weather resistive barrier

Description

Vycor enV® is a rolled or spray-applied, one component, acrylic membrane that forms a continuous water and air barrier with seamless protection.

Vycor enV protects against ingress of incidental water caused by severe weather, vapor or condensation, Vycor enV protects moisture sensitive wood structures in the event of a breach in exterior wall coverings.

Vycor enV is vapor permeable for wall assemblies requiring a “breathable” characteristic. As a vapor permeable membrane, Vycor enV permits the diffusion of water vapor that may otherwise condense in the wall structure; but is impermeable to liquid water, which allows the material to act as a water drainage plane.

The Volatile Organic Compound (VOC) content of Vycor enV is less than 40 g/L.

Advantages

- **Water resistant**—eliminates water intrusion that can have a damaging effect on houses
- **Air resistant**—protects against air leakage and associated energy losses
- **Vapor permeable**—prevents moisture from being trapped in the wall cavity by allowing walls to breathe

VYCOR *enV*®

Product Advantages

- Water resistant
- Air resistant
- Vapor permeable
- Fully bonded
- Seamless
- Easy installation
- Low odor and VOC
- UV resistant up to 4 months
- Compatible with Grace Vycor Flashing Systems

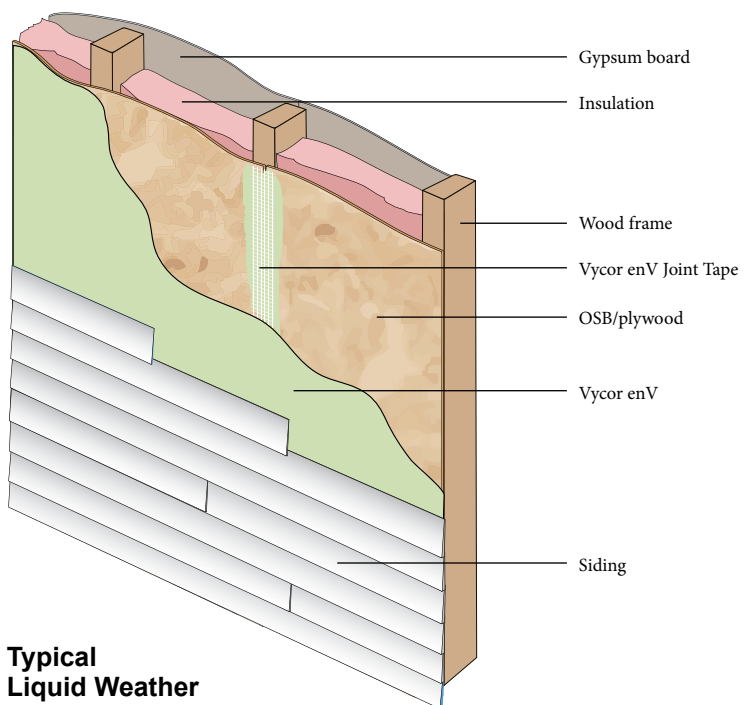

Typical Liquid Weather Resistive Barrier Application

*Consult Grace for climate specific details

Drawings are for illustration purposes only. Please refer to graceconstruction.com for specific application details.

- **Easy installation**—single component that can be easily spray-applied or roller-applied with standard equipment. Requires no mechanical fasteners.
- **Fully adhered**—strong adhesion to OSB and plywood. Unlike housewrap, will not tear away in the wind and expose house to weather damage
- **Seamless**—fluid applied membrane creates a monolithic coating without laps
- **Damp surface tolerant**—can be applied to damp-to-touch surfaces
- **Versatile**—easy to use at details such as internal and external corners, brick ties, penetrations, etc.
- **Low odor and VOC Content**
- **UV resistant**—can be exposed for up to 4 months before cladding installed
- **System solution**—excellent weatherization system when combined with compatible Vycor flashing products

Principal Applications

Liquid weather resistive barrier for new and remedial residential applications on plywood and OSB.

System Components

- **Vycor enV**—acrylic weather resistive barrier for vertical applications
- **Vycor enV Joint Tape**—non-woven 4½ in. (114 mm) wide fabric
- **Vycor Flashing**—heavy duty fully-adhered membrane for flashing detailing
- **Sealants**—Refer to Technical Letter 1 for details on compatible waterproofing sealants

Code Compliance

ICC-ES ESR-3063, AC 212 - *Acceptance criteria for water-resistive coatings used as water-resistive barriers over exterior sheathing*

Installation

Safety

Refer to product label and Material Safety Data Sheet before use. All users should acquaint themselves with this information prior to working with the material. Carefully read detailed precaution statements on the product labels and MSDS before use.

MSDSs can be obtained from our web site at graceconstruction.com or by contacting us toll free at 866-333-3SBM (3726).

Surface Preparation

All surfaces must be sound and free from loose nails or screws, sharp protrusions or other matter that will hinder the adhesion or regularity of the membrane installation. The surface must also

be free from frost, dirt, grease, oil or other contaminants. Clean loose dust and dirt from the surface by brushing or wiping with a clean, dry cloth. Refer to Technical Letter 3, *Application Instructions for Oriented Strand Board (OSB) and Plywood* for further information.

Exterior Sheathing Panels

Vycor enV may be applied directly to exterior sheathing panels such as plywood and oriented strand board (OSB). To avoid deflection at the panel joints, fasten corners and edges with appropriate fasteners. Fasteners should be driven flush with the panel surface (not counter sunk) and into the framing system in accordance with the panel manufacturers recommendations. Joints and holes greater than ¼ in. (6 mm) should be filled with mastic or caulk, allowing sufficient time for the caulk to fully cure before application of the tape and Vycor enV. Spray 8 mil thickness of Vycor enV at the joints and embed in 4½ in. (114 mm) wide Vycor enV Joint Tape.

Detailing

Detailing should be completed prior to applying the full coverage of Vycor enV. The field application should completely cover the detail areas to provide a continuous membrane.

For a complete description and instructions on individual details, consult the separate detail sheets found on our web site at graceconstruction.com.

Transitions to beams, columns, window and doorframes, etc. should be made with a strip of Vycor self-adhered flashing. As soon as the Vycor enV is cured (approximately 24 hrs after application at 50% R.H, 68°F), it is ready to accept the Vycor enV Joint Tape.

Gaps around penetrations should be caulked with a compatible sealant. Consult Technical Letter 1 or contact your Grace Construction Products representative.

Membrane Application

Vycor enV can be installed through a spray application. Vycor enV may be applied by roller, however spray application is the preferred method. If applying Vycor enV by roller, multiple material passes may be necessary to ensure that the required wet thickness is achieved.

Contact Grace for further details of local applicators, application techniques and spray equipment.

Application Temperature—In spray applications, Vycor enV may be applied at temperatures as low as 40°F (4°C). Vycor enV is not recommended for use when cold and/or damp conditions exist for prolonged periods. Vycor enV is a water-based material. As with all water-based materials, it is subject to freezing at temperatures below 32°F (0°C).

Thickness Control

Application thickness is controlled in vertical applications by marking the area and spot-checking the thickness with a wet film thickness gauge. Swipe marks on the surface of the Vycor enV are acceptable as long as the minimum thickness is maintained.

Coverage Rates

Vycor enV is typically applied at a minimum thickness of 30 mils wet. The theoretical coverage rate (not including waste) at a thickness of 30 mils is approximately 55 ft²/gal (275 ft²/pail) to reach a 15 mil dry thickness.

Coverage may vary depending on application technique and may be reduced over rough and uneven substrates. The applicator goal should be a continuous membrane at a thickness of 30 mils wet, adjust coverage rate accordingly.

Drying

Vycor enV is dry to touch and can be overcoated within 4 hours under normal conditions (50% R.H, 68°F). Vycor enV dries through in 24 hours at normal conditions (50% R.H, 68°F). Drying and skinning times may vary depending on temperature, humidity and surface conditions.

Application of Insulation and Finishes

Vycor enV is not suitable for permanent exposure. Insulation boards may be installed after Vycor enV has fully cured. If the insulation cannot be applied within 4 months of the Vycor enV application, some form of temporary protection (such as tarpaulins) should be used to protect the product from the effects of sunlight. Installation of insulation boards can be accomplished by using compatible mechanical fasteners or, solvent free insulation adhesive.

If stucco is used for siding, a separation is required between the stucco and Vycor enV. Two options are:

- A layer of conventional building paper/felt between the stucco lath and Vycor enV
- A type of metal lath or other method that stands the stucco away from the Vycor enV

If a separation sheet is used, it must be permeable to allow the wall system to breath. Any separation sheet recommended by stucco manufacturers is acceptable. Separation sheet should not be applied on Vycor enV until the product is fully cured.

Cleaning

Tools and equipment are most effectively cleaned using a damp cloth and removing material as soon as possible to prevent curing on tools and equipment. For short shutdown periods, material can remain in the lines and equipment. Material should not be left in the lines for any period of time if temperatures are expected to drop below 40°F (4°C). Follow manufacturer recommendations for long shut down, which may include adding anti-rust to the water or filling the pump with oil.

Physical Properties

Property	Typical Value	Test Method
Water penetration resistance	Pass	ASTM E331
Water vapor permeance	>20 perms	ASTM E96
Air leakage	<0.0002 cfm/ft ² @ 1.57 psf	ASTM E283
Adhesion to plywood/OSB	10 lbs/in.*	ASTM D3330 Method F**
Adhesion of Vycor Flashings to Vycor enV	3 lbs/in.	ASTM D3330 Method F**
Tensile strength	400 psi	ASTM D412 Die C
Elongation	200%	ASTM D412 Die C
Color	Green	
Solids content	50%	
Density	1.02 lbs/gal	
Application temperature	minimum 40°F	
Drying time @ 50% R.H. 68°F – initial set	4 hours	
Drying time @ 50% R.H. 68°F	24 hours	
VOC content (g/L)	<40 g/L	

* The value reflects the delamination of the substrate. The actual adhesion value of Vycor enV to substrate is greater than the value given.

** Crosshead speed: 2 in./min.

Storage and Handling

Vycor enV is available in 5 gallon pails. Vycor enV should be stored under cover in original sealed containers above 40°F (4°C) and below 100°F (38°C).

The shelf life is 9 months in unopened containers.

Store opened containers with plastic protective liner covering the material.

Limitations

Do not apply Vycor enV in wet weather. Vycor enV should not be applied if rain or temperatures below 40°F (4°C) are expected within 24 hrs.

Maximum UV exposure period is 4 months.

Vycor enV should be kept from freezing as it is subject to freezing at temperatures below 32°F (0°C).

Finished and exposed surfaces should be protected from overspray.

Vycor enV should not be used in waterproofing applications in hydrostatic condition.

Vycor enV is not compatible with petroleum solvents, fuels and oils, materials containing creosote, pentachlorophenol or linseed oil. Vycor enV has a maximum in-service temperature of 175°F (80°C).

www.graceresidential.com

www.graceconstruction.com

For technical assistance call toll free at 866-333-3SBM (3726)

Vycor and enV are trademarks of W. R. Grace & Co.–Conn. registered in the United States and other countries.

We hope the information here will be helpful. It is based on data and knowledge considered to be true and accurate and is offered for the users' consideration, investigation and verification, but we do not warrant the results to be obtained. Please read all statements, recommendations or suggestions in conjunction with our conditions of sale, which apply to all goods supplied by us. No statement, recommendation or suggestion is intended for any use which would infringe any patent or copyright. W. R. Grace & Co.–Conn., 62 Whittemore Avenue, Cambridge, MA 02140. In Canada, Grace Canada, Inc., 294 Clements Road, West, Ajax, Ontario, Canada L1S 3C6.

This product may be covered by patents or patents pending.
WRB-002F Printed in U.S.A. 05/14

Copyright 2014. W. R. Grace & Co.–Conn.
GCS/PDF

GRACE

GRACE VYCOR® PLUS

Self-adhered flashing

Moisture Control is the First Step to Mold Control

Water from both exterior and interior sources is among the worst enemies of building structures. When water enters the wall system and remains there for a long time, it creates a favorable environment for the development of rot, mold and mildew. Proper waterproofing and flashing practices are necessary to ensure high quality, long-lasting construction.

Repairs of rot and mold are major concerns for homebuilders, contractors, architects, and homeowners. Not only are such repairs difficult, but they are also extremely costly. Window and door openings, deck-to-wall intersections, foundation sill plates, corners, and other penetration areas are the most common water entry points. A self-adhered flashing membrane, properly integrated with the other elements of the building structure, creates a barrier to water and air infiltration and a drainage plane for water to drain out of the wall.

Grace Vycor® Plus high performance self-adhered flashing membrane provides premium protection against water and air infiltration in all critical non-roof detail areas, that traditional building papers, felts and housewraps cannot match. When properly installed, it can reduce the risk of rot and mold development, often associated with costly call-backs.

Product Description

Grace Vycor® Plus self-adhered flashing is composed of durable, cross-laminated, high-density polyethylene sheet, backed by an aggressive, pressure-sensitive rubberized asphalt adhesive.



Product Advantages

- Available with Ripcord® split release on demand
- Easier and faster to install correctly
- Improved product performance
- Proper integration with housewrap/ other weather-resistant barriers
- Reduces the risk of rot and mold development



Grace Vycor® Plus flashing is available in a range of widths: 4 in. (100 mm), 6 in. (150 mm), 9 in. (225 mm), 12 in. (300 mm) and 18 in. (450 mm) to accommodate a variety of job requirements.

Ripcord® split release on demand is available in 6 in. (150 mm), 9 in. (225 mm) and 12 in. (300 mm) wide membranes.

Features & Benefits

Ripcord®—With the sophistication of construction practices it becomes a must to follow the proper sequencing principles. Ripcord® split release offers the flexibility to install half the membrane before and the other half after the other building envelope components are installed, i.e. housewrap or felt. Only in this way are the proper installation principles followed.

Easy to work with—Membrane installation is fast and easy—simply remove the release paper and press onto the substrate. With Grace Vycor® Plus flashings contractors can flash more windows with better quality.

Superior adhesion capabilities—The membrane creates a strong bond to the substrate for long-lasting waterproofing protection.

Seals around fasteners—The specially formulated rubberized asphalt adhesive seals around fasteners, allowing no water to penetrate and get to the substrate.

Forms water-tight laps—Grace Vycor® Plus flashing superior adhesion properties ensure strong laps, even in seams in the flashing.

Measurement markings—The membrane surface is clearly marked at every 6 in. (150 mm) and 12 in. (300 mm) intervals to facilitate the installation procedure.

Highly conformable and flexible—Can accommodate settlement and shrinkage movement.

Proven track record—Grace Vycor® Plus flashing employs the same proven technology as our Grace Ice & Water Shield®—the market leader in self-adhered underlayments for over 35 years.

Long-lasting waterproofing protection—Both the polyethylene film and the specially-formulated rubberized asphalt components create a water and moisture barrier that does not degrade from the effects of the environment.

Usage

Grace Vycor® Plus self-adhered flashing is a unique solution, appropriate for working around a number of detail areas, including, but not limited to:

- Window and door openings (headers, sills, jambs, thresholds, nailing flanges)
- Deck-to-wall intersections
- Inside and outside corners of sheathing
- Wall-to-wall tie-ins
- Foundation sill plates
- Sheathing panel seams
- Under stucco finishes
- Masonry walls
- Other non-roof detail areas

Application Instructions

Surface Preparation

Apply Grace Vycor® Plus flashing in fair weather when the air, surface and membrane are at temperatures of 25°F (-4°C) or higher. After precipitation, allow a minimum of 24 hours for drying before installing the flashing.

Install directly onto a clean and dry surface. Some compatible substrates include wood, plywood, oriented strand board, metal, concrete and masonry. Remove dust, dirt, and loose nails. Protrusions must be removed. Surfaces shall have no voids, damaged, or unsupported areas. Repair surfaces before installing the membrane.

Priming is generally not required for most substrates provided they are clean and dry. However, on concrete, masonry and DensGlass Gold®, apply Perm-A-Barrier® WB Primer. If adhesion is found to be marginal, prime wood composition and gypsum sheathing also with Perm-A-Barrier® WB Primer. The coverage rate for Perm-A-Barrier® WB Primer is 250–350 ft²/gal (6–8 m²/L). Allow primer to dry completely, approximately 1 hour depending on weather conditions, before application of flashing.

Membrane Installation

Using the 6 in. (150 mm) and 12 in. (300 mm) measurement markings, cut the membrane to the desired length. Peel back the release paper to expose the adhesive. Align the membrane and press into place with heavy hand pressure.

Laps must be a minimum of 3 in. (75 mm). Mechanically fasten the membrane at all vertical terminations. Use only smooth shank fasteners.

Consistent with good construction practice, install the membrane such that all laps shed water (following the shingle principle). The top membrane layer should go over the bottom layer. Always work from the low point to the high point. When needed, use Ripcord® split release on demand to split the release paper and adhere

Product Data

Property	Grace Vycor Plus				
Product thickness	25 mil (0.64 mm)				
Carrier film	Cross-laminated HDPE				
Adhesive	Rubberized asphalt				
Release liner	Paper				
Color	Black-Gray				
Recommended exposure limit	30 Days				
Roll width(s)	4 in. (100 mm)	6 in. (150 mm)	9 in. (225 mm)	12 in. (300 mm)	18 in. (450 mm)
Roll length(s)	75 ft (22.9 m)	75 ft (22.9 m)	75 ft (22.9 m)	75 ft (22.9 m)	75 ft (22.9 m)
Rolls per carton	18	12	6	6	2
Shipping weight	74 lbs (33 kg)	74 lbs (33 kg)	56 lbs (25 kg)	74 lbs (33 kg)	36 lbs (16 kg)
Cartons per pallet	30	30	30	30	35

half of the membrane, while leaving the other half with the paper on. This is required when flashing a window sill before the house-wrap/weather resistive barrier is installed.

Precautions & Limitations

Grace Vycor® Plus self-adhered flashing is designed for critical NON-ROOF flashing details. The membrane is slippery—DO NOT install on the roof; DO NOT walk on the membrane.

Do not leave the product permanently exposed to sunlight. Maximum recommended exposure time is 30 days. Due to its slight asphaltic odor, apply this product where the membrane is not exposed to interior living space. Grace Vycor® Plus flashing should not be used in hot desert areas in the southwestern United States.

Grace Vycor® Plus flashing is not compatible with flexible PVC. Contact window manufacturer for specific application instructions required when using a bituminous-based flashing. Certain metal window applications with integral nail fin may have specific limi-

tations. Some solvents in certain caulking may be incompatible with the adhesive in Grace Vycor® Plus flashing.

For more information, check with your local Grace representative.

Approvals

ICBO approved as a Flashing Material (Report ER-6141).- Complies with the requirements of AAMA 711 for self adhered flashing materials.

Key Details for Grace Vycor® Plus

For most recent and additional details, consult our web site at www.graceconstruction.com

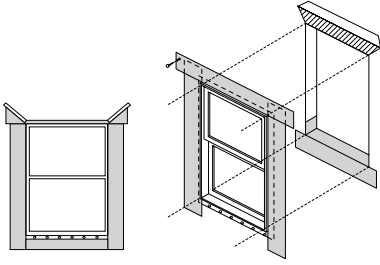

Flanged Window
Flashing Installation AFTER
Weather-Resistive Barrier

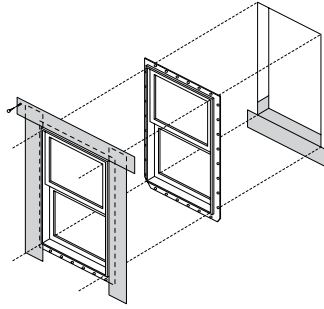

Flanged Window
Flashing Installation BEFORE
Weather-Resistive Barrier
Option 1 – Low Exposure

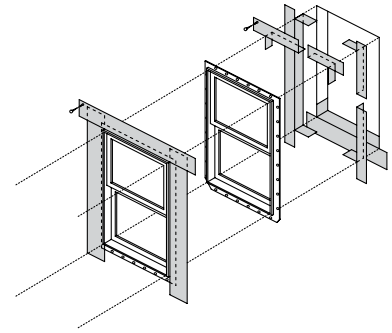

Flanged Window
Flashing Installation BEFORE
Weather-Resistive Barrier
Option 3 – Severe Exposure

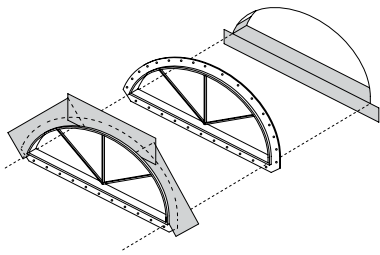

Half Round Window
Option 1 – Low to Moderate
Exposure

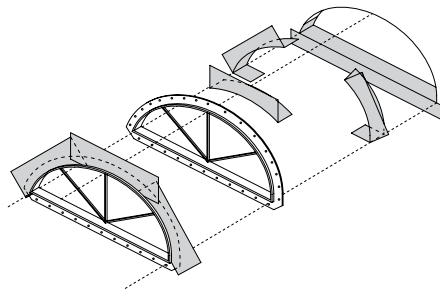

Half Round Window
Option 2 – Severe Exposure

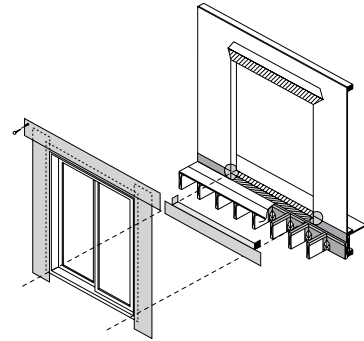

**Exterior Sliding Door
with Deck**

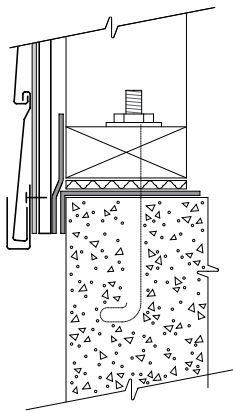

Foundation Sill Plate
Option 1

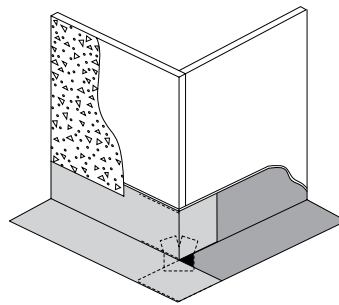

Outside Corner

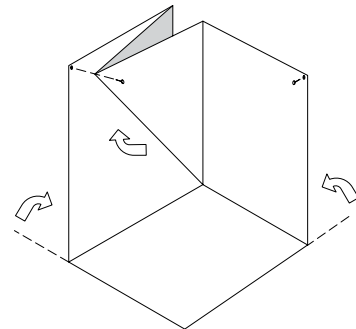

Inside Corner

www.graceresidential.com

For technical assistance call toll free at 866-333-3SBM (3726)

Grace, Vycor, Grace Ice & Water Shield, Perm-A-Barrier and Ripcord are registered trademarks of W. R. Grace & Co.–Conn., registered in the United States and other countries. DensGlass Gold is a registered trademark of Georgia-Pacific Corporation.

This trademark list has been compiled using available published information as of the publication date of this brochure and may not accurately reflect current trademark ownership or status. Grace Construction Products is a business segment of W. R. Grace & Co.–Conn.

We hope the information here will be helpful. It is based on data and knowledge considered to be true and accurate and is offered for the users' consideration, investigation and verification, but we do not warrant the results to be obtained. Please read all statements, recommendations or suggestions in conjunction with our conditions of sale, which apply to all goods supplied by us. No statement, recommendation or suggestion is intended for any use which would infringe any patent or copyright. W. R. Grace & Co.–Conn., 62 Whittemore Avenue, Cambridge, MA 02140. In Canada, Grace Canada, Inc., 294 Clements Road, West, Ajax, Ontario, Canada L1S 3C6.

This product may be covered by patents or patents pending.
TP-083P Printed in U.S.A. 02/14

Copyright 2014. W. R. Grace & Co.–Conn.
GCS/PDF

GRACE

GRACE VYCOR® PRO

High Performance Self-Adhered Flashing with Non-Asphaltic Butyl-Modified Adhesive

The Better the Seal, the Better the Performance

The primary purpose of a flashing tape is to prevent the migration of water and air through window and door openings. Product performance depends on the adhesive bond between the flashing and the substrate. This is especially true for irregularly surfaced materials such as OSB. The better the adhesive seals itself into the peaks and valleys of the substrate, the better the barrier against water and air migration.

Moisture Control is the First Step to Mold Control

Water from both exterior and interior sources is among the worst enemies of building structures. When moisture enters and remains within the wall system, it creates a favorable environment for the development of rot, mold and mildew. Repairing these types of problems can be very difficult and extremely costly.

Product Advantages

- Creates a superior barrier against air and water intrusion
- Optimizes energy performance
- Wide application window for installation flexibility
- 120 days of exposure provides work scheduling flexibility
- Compatible with rigid and flexible PVC window nailing flanges

Air Control is the First Step to Better Energy Performance

The key to optimizing energy performance is preventing the movement of air both into and out of the building envelope. Air leaks around window and door openings make it difficult to keep a comfortable indoor environment, forcing the HVAC system to work harder, while driving up energy costs.

A properly integrated flashing tape that adheres and seals aggressively to the substrate will create the most effective barrier against water and air migration while acting as a drainage plane to shed water down the exterior of the building envelope.

What Makes Vycor® PRO Flashing Different?

Grace Vycor® PRO flashing, with its unique film and non-asphaltic, butyl-modified adhesive technology, provides premium protection against water infiltration in all critical non-roof detail areas, that traditional building papers, felts, housewraps and other flashing products cannot match.



In addition, Grace Vycor® PRO's wide application and service temperature windows make it appropriate for use in any environment.

Product Description

Vycor® Pro flashing is composed of a durable, tear and puncture resistant engineered polypropylene backing film, paired with an aggressive, non-asphaltic, proprietary butyl-modified adhesive. Grace Vycor® PRO flashing comes in 75 ft rolls and is available in:

- 4 in. (102 mm)
- 6 in. (150 mm)
- 9 in. (225 mm)
- 12 in. (305 mm)

Features & Uses

- **Superior adhesive capabilities**—Non-Asphaltic, proprietary butyl-modified adhesive seals and adheres to the substrate creating a best-in-class barrier against air and water intrusion.
- **Seals around fasteners**—The specially formulated adhesive seals around fasteners, preventing water penetration.
- **Forms water-tight laps**—Grace Vycor® PRO's superior adhesion properties ensure strong laps, even at the seams of the flashing.
- **Highly Conformable**—Thin and pliable membrane is easily worked into tight details.
- **Wide application window**—Primerless adhesion to wood sheathing from 25°F (4° C)
- **Wide Service Temperature Window**—Suitable for in-service conditions up to 176° F (80° C)
- **Long exposure time**—120 days of exposure provides protection over long, unpredictable construction cycles
- **Flexible Application**—Grace Vycor® PRO's wide performance window makes it appropriate for use in all regions
- **Easy to work with**—This high performance barrier membrane is easy to apply with 6 and 12 inch (150 mm and 305 mm) measurement markings.
- **Superior Weather Protection Solution**—Use in combination with Grace Vycor® enV-S™ or Grace Vycor enV® fully-adhered weather barriers to provide superior protection from wind driven rain.

Compatibility

- Vycor® Pro flashing contains no asphalt, and is fully compatible with rigid and flexible PVC window nailing flanges.
- Compatible with common weather resistive barriers and many types of sealants. Refer to Technical Letter 1, *Chemical Compatibility with Other Building Materials and Sealants* for more information.

Usage

Grace Vycor® PRO flashing is a unique solution appropriate for working around a number of detail areas, including, but not limited to:

- Window and door openings (headers, sills, jambs, thresholds, nailing flanges)
- Deck-to-wall intersections
- Corner boards
- Wall-to-wall tie-ins
- Foundation sill plates
- Sheathing panel seams
- Under stucco finishes
- Masonry walls
- Application to EPDM in vertical applications
- Other non-roof detail areas

Application Instructions

Apply in fair weather to clean and dry surface at air temperatures of 25°F (4° C) or higher. Apply directly to substrate. Compatible substrates include wood, plywood, oriented strand board, exterior gypsum, metal, concrete and masonry. Install Grace Vycor® PRO flashing with weather-resistive barriers to form water-shedding laps. Cut membrane to length. Peel back release liner. Align membrane and press into place. Mechanically fasten membrane at vertical terminations as necessary. Press or roll into place with hand roller to achieve best adhesion. Primer is generally not required for most substrates (including plywood, OSB, dimensional lumber, PVC window flanges, steel, and aluminum) provided they are clean and dry. On concrete, masonry and glass fiber surfaced gypsum sheathing apply Perm-A-Barrier® WB Primer at a coverage rate of 250–350 ft²/gal (6–8 m²/L). Regardless of substrate, if adhesion is found to be marginal,

Product Data

Property	Grace Vycor® PRO			
Product thickness	14 mil (0.61 mm)			
Carrier film	Engineered Polypropylene			
Adhesive	Non-Asphaltic, Proprietary butyl-modified adhesive			
Release liner	Paper Release			
Color	White with Green Print			
Recommended exposure limit	120 Days			
Roll width(s)	4 in. (102 mm)	6 in. (150 mm)	9 in. (225 mm)	12 in. (305 mm)
Roll length(s)	75 ft (22.9 m)	75 ft (22.9 m)	75 ft (22.9 m)	75 ft (22.9 m)
Rolls per carton	12	8	4	4
Shipping weight per carton	37 lbs (17 kg)	37 lbs (17 kg)	28 lbs (13 kg)	37 lbs (17 kg)
Cartons per pallet	60	60	84	60

prime substrate material with Perm-A-Barrier® WB Primer at the same coverage rate.

Precautions & Limitations

SLIPPERY—DO NOT install on the roof. Do not leave permanently exposed to sunlight. Maximum recommended exposure is 120 days. May be applied to EPDM in vertical applications. Some caulks containing high levels of hydrocarbon solvents may be incompatible with the adhesive in Grace Vycor® PRO flashing. Check with the caulk manufacturer or your local Grace representative and/or refer to Grace Technical Letters on the Grace web site.

Approvals

- Meets AAMA 711-13 specification for self-adhered flashing Level 3 requirement for elevated temperature exposure.

www.graceconstruction.com

For technical assistance call toll free at 866-333-3SBM (3726)

Grace, Vycor and Perm-A-Barrier are trademarks, registered in the United States and/or other countries, of W. R. Grace & Co.-Conn. This trademark list has been compiled using available published information as of the publication date of this brochure and may not accurately reflect current trademark ownership or status.

Grace Construction Products is a business segment of W. R. Grace & Co.-Conn. © Copyright 2014 W. R. Grace & Co.-Conn. All rights reserved.

We hope the information here will be helpful. It is based on data and knowledge considered to be true and accurate and is offered for the users' consideration, investigation and verification, but we do not warrant the results to be obtained. Please read all statements, recommendations or suggestions in conjunction with our conditions of sale, which apply to all goods supplied by us. No statement, recommendation or suggestion is intended for any use which would infringe any patent or copyright. W. R. Grace & Co.-Conn., 62 Whittemore Avenue, Cambridge, MA 02140.
In Canada, Grace Canada, Inc., 294 Clements Road, West, Ajax, Ontario, Canada L1S 3C6.

This product may be covered by patents or patents pending.
TP-153F Printed in U.S.A. 04/14

Copyright 2014. W. R. Grace & Co.-Conn.
GCS/PDF

GRACE

GRACE VYCOR® V40

Self-adhered flashing for critical non-roof detail areas

Moisture control is the first step to mold control.

Water from both exterior and interior sources is among the worst enemies of building structures. When water enters the wall system and remains there for a long time, it creates an environment favorable for the development of rot, mold and mildew. Proper waterproofing and flashing practices are needed to ensure high quality, long-lasting construction.

Repairs resulting from water and moisture infiltration are major concerns for homebuilders, contractors, architects and homeowners as they are difficult repairs and extremely costly. Window and door openings, deck-to-wall intersections, foundation sill plates, corners and other penetration areas are the most common water entry points. The solution—a self-adhered flashing membrane properly integrated with the other elements of the building structure. This will create a barrier to water entry as well as a drainage plane for water to drain out of the wall.

Grace Vycor® V40, a high performance, self-adhered flashing membrane provides premium protection against water infiltration in all critical non-roof detail areas, which traditional building papers, felts and housewraps cannot match.

When properly installed, Grace Vycor V40 can reduce the risk of water infiltration, often associated with costly call-backs.

Grace Vycor V40 fully adheres to the substrate, seals around fasteners and prevents water from passing through and into the structure. It is highly conformable, easy to detail and provides premium protection against leaks. Best of all, Grace Vycor V40 employs the same proven technology as our famous Grace Ice & Water Shield®—the market leader for over thirty years.

Product Advantages

- Premium protection against air, water and moisture infiltration
- Highly conformable
- Protects critical non-roof detail areas including masonry walls and stucco

Product Description

Grace Vycor V40 self-adhered flashing is composed of two waterproofing materials—rubberized asphalt and cross-laminated polyethylene. The product is designed to meet the requirements for weather-resistive barriers as defined by Federal Specification UU-B-790a, Grade A.

Grace Vycor V40 is available in a range of widths: 6 in., 9 in., 12 in. and 18 in. (150 mm, 225 mm, 300 mm and 455 mm) to accommodate a variety of job requirements.

Usage

Grace Vycor V40 provides protection from air, water and moisture infiltration in critical non-roof detail areas, including but not limited to:

- Window and door openings (headers, sills, jambs, thresholds, nailing flanges)
- Deck-to-wall intersections
- Corner boards
- Wall-to-wall tie-ins
- Foundation sill plate
- Sheathing panel seams
- Under stucco finishes
- Masonry walls
- Other non-roof areas

Installation Procedure

Surface Preparation

Install Grace Vycor V40 directly on a clean and dry surface. Some suitable surfaces include plywood, wood composition,



wood plank, metal, concrete or gypsum sheathing. Remove dust, dirt and loose nails. Protrusions must be removed. Surfaces shall have no voids, damaged or unsupported areas. Repair surfaces before installing the membrane.

Priming is generally not required for most substrates provided they are clean and dry. However, on concrete, masonry and DensGlass Gold®, apply Perm-A-Barrier® WB Primer. If adhesion is found to be marginal, also prime wood composition and gypsum sheathing with Perm-A-Barrier WB Primer. The coverage rate for Perm-A-Barrier WB Primer is 250–350 ft²/gal (6–8 m²/L).

Membrane Installation

Apply Grace Vycor V40 in fair weather when the air, surface and membrane are at temperatures of 25°F (-4°C) or higher. After precipitation, allow a minimum of 24 hours for drying before installing the flashing.

Cut the membrane to appropriate length. Peel back the release liner, align the membrane, press into place and firmly roll. Laps must be a minimum of 3 in. (75 mm). Mechanically fasten the membrane at vertical terminations. Consistent with good construction practices, install Grace Vycor V40 such that all laps shed water. The top membrane layer should go over the bottom layer. Always work from the low point to the high point.

Precautions and Limitations

Grace Vycor V40 is designed for non-roof detail areas. This product is slippery—DO NOT walk on the membrane.

Do not leave Grace Vycor V40 permanently exposed to sunlight. Maximum recommended exposure is 30 days.

Grace Vycor V40 should not be used in hot desert areas in the southwestern United States.

Due to its slight asphaltic odor, apply Grace Vycor V40 where it is not exposed to interior living space. The product is incompatible with creosote, joint sealants containing polysulfide polymer, products manufactured from EPDM, flexible PVC, as well as certain caulks. Refer to Tapes Technical Letter 1, *Chemical Compatibility*, for further details. Contact window manufacturer for specific application instructions required when using a self-adhering, bituminous-based flashing. Certain metal window applications with integral nailing fin may have specific limitations. For more information, contact your local Grace representative.

Warranty

Grace Vycor V40 is warranted at the time of shipment to meet Grace’s published specifications.

Approvals

Approved as a flashing material (ICC ER-6141).

Property	Grace Vycor V40			
Product thickness	40 mil (1.02 mm)			
Carrier film	Cross-laminated HDPE			
Adhesive	Rubberized asphalt			
Release liner	Paper			
Color	Black-Gray			
Recommended exposure limit	30 Days			
Shrink Wrapped Rolls				
Roll width(s)	6 in. (150 mm)	9 in. (225 mm)	12 in. (300 mm)	
Roll length(s)	50 ft (15.2m)	50 ft (15.2m)	50 ft (15.2m)	
Rolls per carton	12	6	6	
Bulk Rolls				
Roll width(s)	6 in. (150 mm)	9 in. (225 mm)	12 in. (300 mm)	18 in. (455 mm)
Roll length(s)	75 ft (22.9m)	75 ft (22.9m)	75 ft (22.9m)	75 ft (22.9m)
Rolls per carton	6	4	3	2

www.graceconstruction.com

For technical assistance call toll free at 866-333-3SBM (3726)

Vycor, Grace Ice & Water Shield and Perm-A-Barrier are registered trademarks of W. R. Grace & Co.–Conn. DensGlass Gold is a registered trademark of Georgia-Pacific Corporation.

We hope the information here will be helpful. It is based on data and knowledge considered to be true and accurate and is offered for the users’ consideration, investigation and verification, but we do not warrant the results to be obtained. Please read all statements, recommendations or suggestions in conjunction with our conditions of sale, which apply to all goods supplied by us. No statement, recommendation or suggestion is intended for any use which would infringe any patent or copyright. W. R. Grace & Co.–Conn., 62 Whittemore Avenue, Cambridge, MA 02140. In Canada, Grace Canada, Inc., 294 Clements Road, West, Ajax, Ontario, Canada L1S 3C6.

This product may be covered by patents or patents pending.
TP-073J Printed in U.S.A. 08/14

Copyright 2014. W. R. Grace & Co.–Conn.
GCS/PDF



GRACE VYCOR® ALUMINUM FLASHING

Self-adhered flashing

Moisture Control is the First Step to Mold Control

Water from both exterior and interior sources is among the worst enemies of building structures. When water enters the building envelope and remains there for a long time, it creates a favorable environment for the development of rot, mold and mildew. Proper waterproofing and flashing practices are necessary to ensure high quality, long-lasting construction.

Repairs of rot and mold are major concerns for homebuilders, contractors, architects, and homeowners. Not only are such repairs difficult, but they are also extremely costly. Window and door openings, deck-to-wall intersections, foundation sill plates, corners, roof details, and other penetration areas are the most common water entry points. A self-adhered flashing membrane, properly integrated with the other elements of the building structure, creates a barrier to water entry and a drainage plane for water to drain out of the building envelope.

Grace Vycor® Aluminum Flashing, a high performance self-

adhered flashing membrane, provides premium protection against water infiltration in all critical detail areas, that traditional building papers, felts and housewraps cannot match. When properly installed, it can reduce the risk of rot and mold development, often associated with costly call-backs.



Product Advantages

- Available with Ripcord® split release on demand
- Easier and faster to install correctly
- Improved product performance
- Proper integration with housewrap, felt and other weather resistive barriers
- Reduces the risk of rot and mold development
- Provides waterproofing protection for leak areas where flashing is left exposed
- Seals around nails



Product Description

Grace Vycor Aluminum Flashing self-adhered flashing is composed of durable, cross-laminated, high density polyethylene aluminum surfaced sheet, backed by an aggressive, pressure sensitive rubberized asphalt adhesive.

Grace Vycor Aluminum Flashing is available in the following widths: 4 in. (100 mm) and 6 in. (150 mm) to accommodate a variety of job requirements.

Ripcord is available in 6 in. width.

Features & Benefits

Ripcord—With the sophistication of construction practices it becomes a must to follow the proper sequencing principles. Ripcord offers the flexibility to install half the membrane before and the other half after the other building envelope components are installed, i.e. housewrap or felt. Only in this way are the proper installation principles followed.

Easy to work with—Membrane installation is fast and easy—simply remove the release paper and press onto the substrate. With Grace Vycor Aluminum Flashing contractors can flash more details with better quality.

Superior adhesion capabilities—

The membrane creates a strong bond to the substrate for long-lasting waterproofing protection.

Seals around fasteners—The specially formulated rubberized asphalt adhesive seals around fasteners, allowing no water to penetrate and get to the substrate.

Forms water-tight laps—Grace Vycor Aluminum Flashing's superior adhesion properties ensure strong laps.

Highly conformable and flexible—

Can accommodate settlement and shrinkage movement.

Proven track record—Grace Vycor Aluminum Flashing employs the same proven technology as our Grace Ice & Water Shield®—the market leader in self-adhered underlayments for over 30 years.

Long-lasting waterproofing protection—Both the aluminum surfaced polyethylene film and the specially-formulated rubberized asphalt components create a water and moisture barrier that does not degrade from the effects of the environment.

Usage

Grace Vycor Aluminum Flashing is a unique solution, appropriate for working around a number of detail areas, including, but not limited to:

- Window and door openings (headers, sills, jambs, thresholds, nailing flanges)
- Deck-to-wall intersections
- Corner boards
- Wall-to-wall tie-ins
- Foundation sill plates
- Sheathing panel seams

- Under stucco finishes
- Masonry walls
- Roof detail areas
- Gutters
- Mobile home repair

Application Instructions

Surface Preparation

Apply Grace Vycor Aluminum Flashing in fair weather when the air, surface and membrane are at temperatures of 25°F (-4°C) or higher. After precipitation, allow a minimum of 24 hours for drying before installing the flashing.

Install directly onto a clean and dry surface. Some compatible substrates include wood, plywood, oriented strand board, metal, concrete and masonry. Remove dust, dirt, and loose nails. Protrusions must be removed. Surfaces shall have no voids, damaged, or unsupported areas. Repair surfaces before installing the membrane.

Priming is generally not required for most substrates provided they are clean and dry. However, on concrete, masonry and DensGlass Gold®, apply Perm-A-Barrier® WB Primer. If adhesion is found to be marginal, prime wood composition and gypsum sheathing also with Perm-A-Barrier WB Primer. The coverage rate for Perm-A-

Product Data

Property	Grace Vycor Aluminum Flashing	
Product thickness	25 mil (0.64 mm)	
Carrier film	Aluminum surfaced, cross-laminated HDPE	
Adhesive	Rubberized asphalt	
Release liner	Paper	
Color	Aluminum	
Recommended exposure limit	Can be left exposed	
Roll width(s)	4 in. (100 mm)	6 in. (150 mm)
Roll length(s)	50 ft (22.9 m)	50 ft (22.9 m)
Rolls per carton	18	12
Shipping weight	74 lbs (33 kg)	74 lbs (33 kg)
Cartons per pallet	30	30

Barrier WB Primer is 250–350 ft²/gal (6–8 m²/L). Allow primer to dry completely, approximately 1 hour depending on weather conditions, before application of flashing.

Membrane Installation

Cut the membrane to the desired length. Peel back the release paper to expose the adhesive. Align the membrane and press into place with heavy hand pressure.

Laps must be a minimum of 3 in. (75 mm). Mechanically fasten the membrane at all vertical terminations. Use only smooth shank fasteners.

Consistent with good construction practice, install the membrane such that all laps shed water (following the shingle principle).

The top membrane layer should go over the bottom layer.

Always work from the low point to the high point. When needed, use Ripcord to split the release paper and adhere half of the membrane, while leaving the other half with the paper on. This is required when flashing a window sill before the housewrap/weather resistive barrier is installed.

Precautions & Limitations

The membrane is slippery—DO NOT walk on the membrane. Consistent with good roofing practice, always wear fall protection when working on a roof deck.

Due to its slight asphaltic odor, apply this product where the membrane is not exposed to interior living space. Grace Vycor Aluminum Flashing should not be used in hot desert areas in the southwestern United States.

Grace Vycor Aluminum Flashing is not compatible with flexible PVC. Contact window manufacturer for specific application instructions required when using a bituminous-based flashing. Certain metal window applications with integral nail fin may have specific limitations. Some solvents in certain caulking may be incompatible with the adhesive in Grace Vycor Aluminum Flashing.

For more information, check with your local Grace representative.

Approvals & Standards

Engineered to meet ICC AC148 and AAMA E2112.

Key Details for Grace Vycor Aluminum Flashing

For most recent and additional details, consult our web site at www.graceconstruction.com

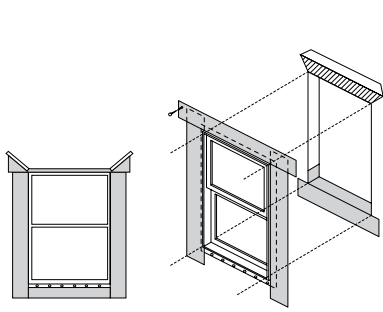

Flanged Window
Flashing Installation AFTER
Weather-Resistive Barrier

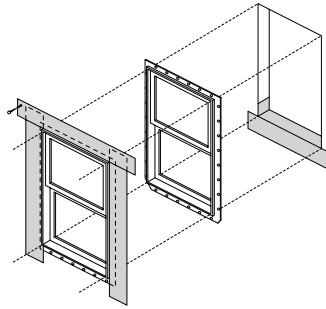

Flanged Window
Flashing Installation BEFORE
Weather-Resistive Barrier
Option 1 – Low Exposure

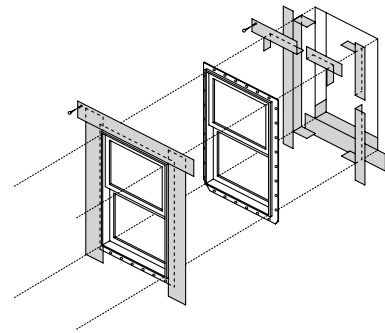

Flanged Window
Flashing Installation BEFORE
Weather-Resistive Barrier
Option 3 – Severe Exposure

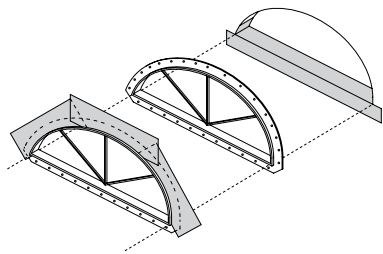

Half Round Window
Option 1 – Low to Moderate
Exposure

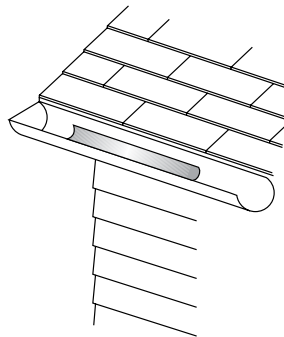

Gutter & Chimney

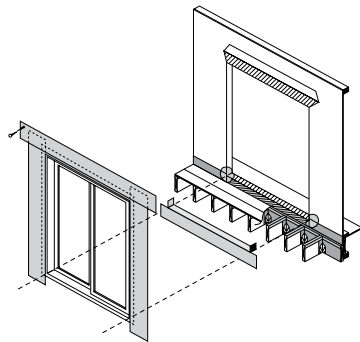
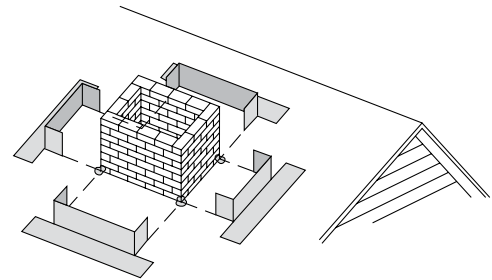

**Exterior Sliding Door
with Deck**

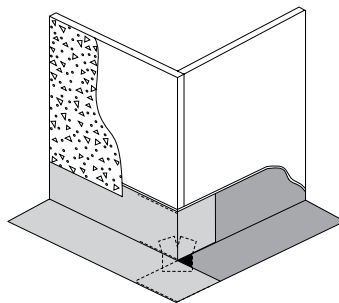

Outside Corner

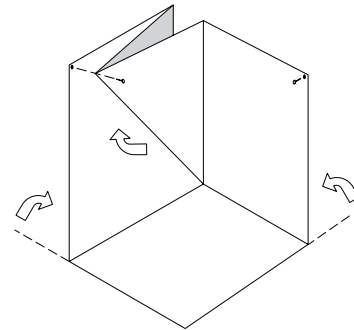

Inside Corner

www.graceconstruction.com

For technical assistance call toll free at 866-333-3SBM (3726)

Vycor, Grace Ice & Water Shield, Perm-A-Barrier and Ripcord are registered trademarks of W. R. Grace & Co.–Conn. DensGlass Gold is a registered trademark of Georgia-Pacific Corporation.

We hope the information here will be helpful. It is based on data and knowledge considered to be true and accurate and is offered for the users' consideration, investigation and verification, but we do not warrant the results to be obtained. Please read all statements, recommendations or suggestions in conjunction with our conditions of sale, which apply to all goods supplied by us. No statement, recommendation or suggestion is intended for any use which would infringe any patent or copyright. W. R. Grace & Co.–Conn., 62 Whittemore Avenue, Cambridge, MA 02140. In Canada, Grace Canada, Inc., 294 Clements Road, West, Ajax, Ontario, Canada L1S 3C6.

This product may be covered by patents or patents pending.
TP-150C Printed in U.S.A. 08/14

Copyright 2014. W. R. Grace & Co.–Conn.
GCS/PDF

GRACE

Grace Below Grade Waterproofing

BITUTHENE® SYSTEM 4000

Self-adhesive HDPE waterproofing membrane with super tacky compound for use with patented, water-based Bituthene® System 4000 Surface Conditioner

Description

Bituthene® System 4000 Waterproofing Membrane is a 1.5 mm ($\frac{1}{16}$ in.) flexible, pre-formed membrane which combines a high performance, cross laminated, HDPE carrier film with a unique, super tacky, self-adhesive rubberized asphalt compound.

Bituthene® System 4000 Surface Conditioner is a water-based, latex surface treatment which imparts an aggressive, high tack finish to the treated substrate. It is specifically formulated to bind site dust and concrete efflorescence, thereby providing a suitable surface for the Bituthene® System 4000 Waterproofing Membrane.

Conveniently packaged in each roll of membrane, Bituthene® System 4000 Surface Conditioner promotes good initial adhesion and, more importantly, excellent permanent adhesion of the Bituthene® System 4000 Waterproofing Membrane. The VOC (Volatile Organic Compound) content of this product is 100 g/L.

Architectural and Industrial Maintenance Regulations limit the VOC content in products classified as Architectural Coatings. Refer to Technical Letters at graceconstruction.com for most current list of allowable limits.

Product Advantages

- Excellent adhesion
- Cold applied
- Reduced inventory and handling costs
- Wide application temperature range
- Overlap security
- Cross laminated, high density polyethylene carrier film
- Flexible
- Ripcord®

Advantages

- **Excellent adhesion**—special adhesive compound engineered to work with high tack System 4000 Surface Conditioner
- **Cold applied**—simple application to substrates, especially at low temperatures
- **Reduced inventory and handling costs**—System 4000 Surface Conditioner is included with each roll of membrane
- **Wide application temperature range**—excellent bond to self and substrate from 25°F (-4°C) and above

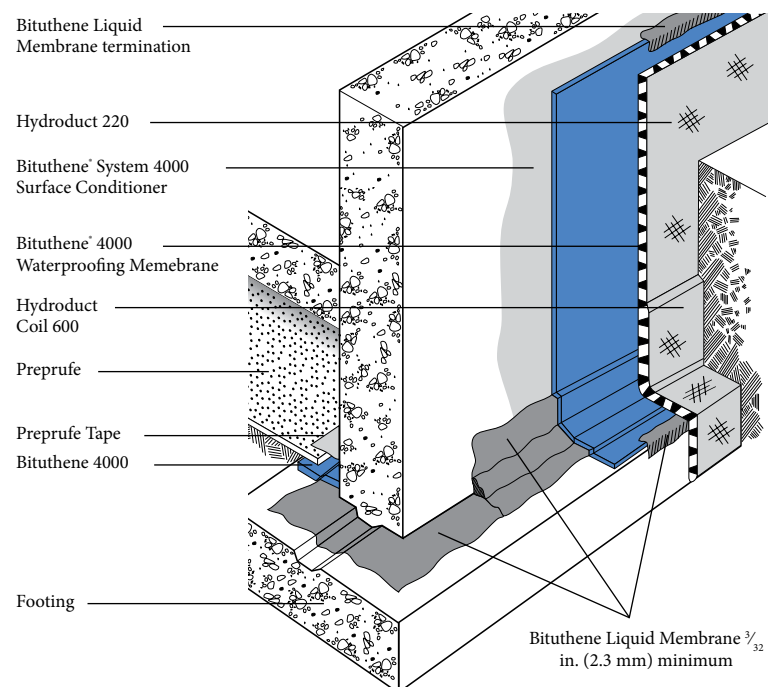

Drawings are for illustration purposes only.
Please refer to graceconstruction.com for specific application details.

- **Overlap security**—minimizes margin for error under site conditions
- **Cross laminated, high density polyethylene carrier film**—provides high tear strength, puncture and impact resistance
- **Flexible**—accommodates minor structural movements and will bridge shrinkage cracks
- **Ripcord**[®]—this split release on demand feature allows the splitting of the release paper into two (2) pieces for ease of installation in detailed areas

Use

Bituthene[®] membrane is ideal for waterproofing concrete, masonry and wood surfaces where in-service temperatures will not exceed 135°F (57°C). It can be applied to foundation walls, tunnels, earth sheltered structures and split slab construction, both above and below grade. (For above grade applications, see *Above Grade Waterproofing Bituthene[®] System 4000*.)

Bituthene[®] waterproofing membrane is 1/16 in. (1.5 mm) thick, 3 ft (0.9 m) wide and 66.7 ft (20 m) long and is supplied in rolls. It is unrolled sticky side down onto concrete slabs or applied onto vertical concrete faces primed with Bituthene[®] System 4000 Surface Conditioner. Continuity is achieved by overlapping a minimum 2 in. (50 mm) and firmly rolling the joint.

Bituthene[®] membrane is extremely flexible. It is capable of bridging shrinkage cracks in the concrete and will accommodate minor differential movement throughout the service life of the structure.

Application Procedures

Safety, Storage and Handling Information

Bituthene[®] products must be handled properly. Vapors from solvent-based primers and mastic are harmful and flammable.

For these products, the best available information on safe handling, storage, personal protection, health and environmental considerations has been gathered. Material Safety Data Sheets (MSDS) are available at graceconstruction.com and users should acquaint themselves with this information. Carefully read detailed precaution statements on product labels and the MSDS before use.

Surface Preparation

Surfaces should be structurally sound and free of voids, spalled areas, loose aggregate and sharp protrusions. Remove contaminants such as grease, oil and wax from exposed surfaces. Remove dust, dirt, loose stone and debris. Concrete must be properly dried (minimum

7 days for normal structural concrete and 14 days for lightweight structural concrete).

If time is critical, Bituthene[®] Primer B2 or Bituthene[®] Primer B2 LVC may be used to allow priming and installation of membrane on damp surfaces or green concrete. Priming may begin in this case as soon as the concrete will maintain structural integrity. Use form release agents which will not transfer to the concrete. Remove forms as soon as possible from below horizontal slabs to prevent entrapment of excess moisture. Excess moisture may lead to blistering of the membrane. Cure concrete with clear, resin-based curing

compounds which do not contain oil, wax or pigment. Except with Bituthene[®] Primer B2 or Bituthene[®] Primer B2 LVC, allow concrete to thoroughly dry following rain. Do not apply any products to frozen concrete.

Repair defects such as spalled or poorly consolidated areas. Remove sharp protrusions and form match lines. On masonry surfaces, apply a parge coat to rough concrete block and brick walls or trowel cut mortar joints flush to the face of the concrete blocks.

Temperature

- Apply Bituthene[®] System 4000 Membrane and Conditioner only in dry weather and when air and surface temperatures are 25°F (-4°C) or above.
- Apply Bituthene[®] Primer B2 or Bituthene[®] Primer B2 LVC in dry weather above 25°F (-4°C). (See separate product information sheet.)

Conditioning

Bituthene[®] System 4000 Surface Conditioner is ready to use and can be applied by spray or roller. For best results, use a pump-type air sprayer with fan tip nozzle, like the Bituthene[®] System 4000 Surface Conditioner Sprayer, to apply the surface conditioner.

Apply Bituthene[®] System 4000 Surface Conditioner to clean, dry, frost-free surfaces at a coverage rate of 300 ft²/gal (7.4 m²/L). Coverage should be uniform. Surface conditioner should not be applied so heavily that it puddles or runs. **Do not apply conditioner to Bituthene[®] membrane.**

Allow Bituthene[®] System 4000 Surface Conditioner to dry one hour or until substrate returns to its original color. At low temperatures or in high humidity conditions, dry time may be longer.

Bituthene[®] System 4000 Surface Conditioner is clear when dry and may be slightly tacky. In general, conditioning should be limited to what can be covered within 24 hours. In situations where long dry times may prevail, substrates may be conditioned in advance. Substrates should be reconditioned if significant dirt or dust accumulates.

Before surface conditioner dries, tools should be cleaned with water. After surface conditioner dries, tools should be cleaned with mineral spirits. Mineral spirits is a combustible liquid which should be used only in accordance with manufacturer's recommendations. **Do not use solvents to clean hands or skin.**

Corner Details

The treatment of corners varies depending on the location of the corner. For detailed information on Bituthene® Liquid Membrane, see separate product information sheet.

- At wall to footing inside corners—

Option 1: Apply membrane to within 1 in. (25 mm) of base of wall. Treat the inside corner by installing a $\frac{3}{4}$ in. (20 mm) fillet of Bituthene® Liquid Membrane. Extend Bituthene® Liquid Membrane at least $2\frac{1}{2}$ in. (65 mm) onto footing, and $2\frac{1}{2}$ in. (65 mm) onto wall membrane.

Option 2: Treat the inside corner by installing a $\frac{3}{4}$ in. (20 mm) fillet of Bituthene® Liquid Membrane. Apply 12 in. (300 mm) wide strip of sheet membrane centered over fillet. Apply wall membrane over inside corner and extend 6 in. (150 mm) onto footing. Apply 1 in. (25 mm) wide troweling of Bituthene® Liquid Membrane over all terminations and seams within 12 in. (300 mm) of corner.

- At footings where the elevation of the floor slab is 6 in. (150 mm) or more above the footing, treat the inside corner either by the above two methods or terminate the membrane at the base of the wall. Seal the termination with Bituthene® Liquid Membrane.

Joints

Properly seal all joints with waterstop, joint filler and sealant as required. Bituthene® membranes are not intended to function as the primary joint seal. Allow sealants to fully cure. Pre-strip all slab and wall cracks over $\frac{1}{16}$ in. (1.5 mm) wide and all construction and control joints with 9 in. (230 mm) wide sheet membrane strip.

Application on Horizontal Surfaces

(Note: Preprufe® pre-applied membranes are strongly recommended for below slab or for any application where the membrane is applied before concreting. See Preprufe® waterproofing membrane product information sheets.)

Apply membrane from the low point to the high point so that laps shed water. Overlap all seams at least 2 in. (50 mm). Stagger all end laps. Roll the entire membrane firmly and completely as soon as possible. Use a linoleum roller or standard water-filled garden roller less than 30 in. (760 mm) wide, weighing a minimum of 75 lbs (34 kg) when filled. Cover the face of the roller with a resilient material such as a $\frac{1}{2}$ in. (13 mm) plastic foam or two wraps of indoor-outdoor carpet to allow the membrane to fully contact the primed substrate. Seal all T-joints and membrane terminations with Bituthene® Liquid Membrane at the end of the day.

Protrusions and Drains

Apply membrane to within 1 in. (25 mm) of the base of the protrusion. Apply Bituthene® Liquid Membrane 0.1 in. (2.5 mm) thick around protrusion. Bituthene® Liquid Membrane should extend over the membrane a minimum of $2\frac{1}{2}$ in. (65 mm) and up the penetration to just below the finished height of the wearing course.

Vertical Surfaces

Apply membrane in lengths up to 8 ft (2.5 m). Overlap all seams at least 2 in. (50 mm). On higher walls apply membrane in two or more sections with the upper overlapping the lower by at least 2 in. (50 mm). Roll all membrane with a hand roller.

Terminate the membrane at grade level. Press the membrane firmly to the wall with the butt end of a hardwood tool such as a hammer handle or secure into a reglet. Failure to use heavy pressure at terminations can result in a poor seal. A termination bar may be used to ensure a tight seal. Terminate the membrane at the base of the wall if the bottom of the interior floor slab is at least 6 in. (150 mm) above the footing. Otherwise, use appropriate inside corner detail where the wall and footing meet.

Membrane Repairs

Patch tears and inadequately lapped seams with membrane. Clean membrane with a damp cloth and dry. Slit fishmouths and repair with a patch extending 6 in. (150 mm) in all directions from the slit and seal edges of the patch with Bituthene® Liquid Membrane. Inspect the membrane thoroughly before covering and make any repairs.

Drainage

Hydroduct® drainage composites are recommended for both active drainage and protection of the membrane. See Hydroduct® product information sheets.

Protection of Membrane

Protect Bituthene® membranes to avoid damage from other trades, construction materials or backfill. Place protection immediately in temperatures above 77°F (25°C) to avoid potential for blisters.

- On vertical applications, use Hydroduct® 220 Drainage Composite. Adhere Hydroduct® 220 Drainage Composite to membrane with Preprufe® Detail Tape. Alternative methods of protection are to use 1 in. (25 mm) expanded polystyrene or $\frac{1}{4}$ in. (6 mm) extruded

polystyrene that has a minimum compressive strength of 8 lbs/in.² (55 kN/m²). Such alternatives do not provide positive drainage to the system. If ¼ in.

(6 mm) extruded polystyrene protection board is used, backfill should not contain sharp rock or aggregate over 2 in. (50 mm) in diameter. Adhere polystyrene protection board with Preprufe® Detail Tape.

- In mud slab waterproofing, or other applications where positive drainage is not desired and where reinforced concrete slabs are placed over the membrane, the use of ¼ in. (6 mm) hardboard or 2 layers of ⅛ in. (3 mm) hardboard is recommended.

Insulation

Always apply Bituthene® membrane directly to primed or conditioned structural substrates. Insulation, if used, must be applied over the membrane. Do not apply Bituthene® membranes over lightweight insulating concrete.

Backfill

Place backfill as soon as possible. Use care during backfill operation to avoid damage to the waterproofing system. Follow generally accepted practices for backfilling and compaction. Backfill should be added and compacted in 6 in. (150 mm) to 12 in. (300 mm) lifts.

For areas which cannot be fully compacted, a termination bar is recommended across the top termination of the membrane.

Placing Steel

When placing steel over properly protected membrane, use concrete bar supports (dobies) or chairs with plastic tips or rolled feet to prevent damage from sharp edges. Use special care when using wire mesh, especially if the mesh is curled.

Approvals

- City of Los Angeles Research Report RR 24386
- Miami-Dade County Code Report NOA 04-0114.03
- U.S. Department of Housing and Urban Development (HUD) HUD Materials Release 628E

Bituthene System 4000 Surface Conditioner Sprayer

The Bituthene® System 4000 Surface Conditioner Sprayer is a professional grade, polyethylene, pump-type, compressed air sprayer with a brass fan tip nozzle. It has a 2 gal (7.6 L) capacity. The nozzle orifice and spray pattern have been specifically engineered for the optimum application of Bituthene® System 4000 Surface Conditioner.

Hold nozzle 18 in. (450 mm) from substrate and squeeze handle to spray. Spray in a sweeping motion until substrate is uniformly covered.

Sprayer should be repressurized by pumping as needed. For best results, sprayer should be maintained at high pressure during spraying.

To release pressure, invert the sprayer and spray until all compressed air is released.



Maintenance

The Bituthene® System 4000 Surface Conditioner Sprayer should perform without trouble for an extended period if maintained properly.

Sprayer should not be used to store Bituthene® System 4000 Surface Conditioner. The sprayer should be flushed with clean water immediately after spraying. For breaks in the spray operation of one hour or less, invert the sprayer and squeeze the spray handle until only air comes from the nozzle. This will avoid clogging.

Should the sprayer need repairs or parts, call the maintenance telephone number on the sprayer tank (800-323-0620).

- Bituthene® 4000 Membranes carry a Underwriters' Laboratory Class A Fire Rating (Building Materials Directory, File #R7910) when used in either of the following constructions:
 - Limited to noncombustible decks at inclines not exceeding $\frac{1}{4}$ in. (6 mm) to the horizontal 1 ft (0.3 m). One layer of Bituthene® waterproofing membrane, followed by one layer of $\frac{1}{8}$ in. (3 mm) protection board, encased in 2 in. (50 mm) minimum concrete monolithic pour.
 - Limited to noncombustible decks at inclines not exceeding $\frac{1}{4}$ in. (6 mm) to the horizontal 1 ft (0.3 m). One layer of Bituthene® waterproofing membrane, followed by one layer of DOW Styrofoam PD Insulation Board [2 in. (50 mm) thick]. This is covered with one layer of 2 ft x 2 ft x 2 in. (0.6 m x 0.6 m x 50 mm) of concrete paver topping.

Warranty

Five year material warranties covering Bituthene® and Hydroduct® products are available upon request. Contact your Grace sales representative for details.

Technical Services

Support is provided by full time, technically trained Grace representatives and technical service personnel, backed by a central research and development staff.

Supply

Bituthene® System 4000	3 ft x 66.7 ft roll (200 ft ²) [0.9 m x 20 m (18.6 m ²)]
Roll weight	83 lbs (38 kg) gross
Palletization	25 rolls per pallet
Storage	Store upright in dry conditions below 95°F (+35°C).
System 4000 Surface Conditioner	1 x 0.625 gal (2.3 L) bottle in each roll of System 4000 Membrane
Ancillary Products	
Surface Conditioner Sprayer	2 gal (7.6 L) capacity professional grade sprayer with specially engineered nozzle
Bituthene® Liquid Membrane	1.5 gal (5.7 L) pail/125 pails per pallet or 4 gal (15.1 L) pail/48 pails per pallet
Preprufe® Detail Tape	2 in. x 50 ft (50 mm x 15 m) roll/16 rolls per carton
Bituthene® Mastic	Twelve 30 oz (0.9 L) tubes/carton or 5 gal (18.9 L) pail/36 pails per pallet
Complementary Material	
Hydroduct®	See separate data sheets

Equipment by others:

Soft broom, utility knife, brush or roller for priming

Physical Properties for Bituthene® System 4000 Waterproofing Membrane

Property	Typical Value	Test Method
Color	Dark gray-black	
Thickness	1/16 in. (1.5 mm) nominal	ASTM D3767—method A
Flexibility, 180° bend over 1 in. (25 mm) mandrel at -25°F (-32°C)	Unaffected	ASTM D1970
Tensile strength, membrane, die C	325 lbs/in. ² (2240 kPa) minimum	ASTM D412 modified ¹
Tensile strength, film	5,000 lbs/in. ² (34.5 MPa) minimum	ASTM D882 modified ¹
Elongation, ultimate failure of rubberized asphalt	300% minimum	ASTM D412 modified ¹
Crack cycling at -25°F (-32°C), 100 cycles	Unaffected	ASTM C836
Lap adhesion at minimum application temperature	5 lbs/in. (880 N/m)	ASTM D1876 modified ²
Peel strength	9 lbs/in. (1576 N/m)	ASTM D903 modified ³
Puncture resistance, membrane	50 lbs (222 N) minimum	ASTM E154
Resistance to hydrostatic head	231 ft (71 m) of water	ASTM D5385
Permeance	0.05 perms (2.9 ng/m ² sPa) maximum	ASTM E96, section 12—water method
Water absorption	0.1% maximum	ASTM D570

Footnotes:

1. The test is run at a rate of 2 in. (50 mm) per minute.
2. The test is conducted 15 minutes after the lap is formed and run at a rate of 2 in. (50 mm) per minute at 40°F (5°C).
3. The 180° peel strength is run at a rate of 12 in. (300 mm) per minute.

Physical Properties for Bituthene® System 4000 Surface Conditioner

Property	Typical Value
Solvent type	Water
Flash point	>140°F (>60°C)
VOC* content	91 g/L
Application temperature	25°F (-4°C) and above
Freeze thaw stability	5 cycles (minimum)
Freezing point (as packaged)	14°F (-10°C)
Dry time (hours)	1 hour**

* Volatile Organic Compound

** Dry time will vary with weather conditions

www.graceconstruction.com

For technical assistance call toll free at 866-333-3SBM (3726)

GRACE®, Bituthene, Preprufe, Hydroduct and Ripcord are trademarks, registered in the United States and/or other countries, of W. R. Grace & Co.-Conn. This trademark list has been compiled using available published information as of the publication date of this brochure and may not accurately reflect current trademark ownership or status. Grace Construction Products is a business segment of W. R. Grace & Co.-Conn. © Copyright 2014 W. R. Grace & Co.-Conn. All rights reserved.

We hope the information here will be helpful. It is based on data and knowledge considered to be true and accurate and is offered for the users' consideration, investigation and verification, but we do not warrant the results to be obtained. Please read all statements, recommendations or suggestions in conjunction with our conditions of sale, which apply to all goods supplied by us. No statement, recommendation or suggestion is intended for any use which would infringe any patent or copyright. W. R. Grace & Co.-Conn., 62 Whittemore Avenue, Cambridge, MA 02140. In Canada, Grace Canada, Inc., 294 Clements Road, West, Ajax, Ontario, Canada L1S 3C6.

This product may be covered by patents or patents pending.
BIT-2201 Printed in U.S.A. 04/14

Copyright 2014 W. R. Grace & Co.-Conn.
GCS/PDF

GRACE

FLORPRUFE® 120

Integrally bonded vapor protection for slabs on grade

Description

Florprufe® 120 is a high performance vapor barrier with Grace's Advanced Bond Technology™ that forms a unique seal to the underside of concrete floor slabs.

Comprising a highly durable polyolefin sheet and a specially developed, non-tacky adhesive coating, Florprufe 120 seals to liquid concrete to provide integrally bonded vapor protection.

Florprufe exceeds ASTM E1745 Class A rating.

Advantages

- Forms a powerful integral seal to the underside of concrete slabs
- Protects valuable floor finishes such as wood, tiles, carpet and resilient flooring from damage by vapor transmission
- Direct contact with the slab complies with the latest industry recommendations
- Remains sealed to the slab even in cases of ground settlement
- Ultra low vapor permeability
- Durable, chemical resistant polyolefin sheet
- Lightweight, easy to apply, kick out rolls
- Simple lap forming with mechanical fixings or tape

Use

Florprufe 120 is engineered for use below slabs on grade with moisture-impermeable or moisture-sensitive floor finishes that require the highest level of vapor protection.

Florprufe complies with the latest recommendations of ACI Committees 302 and 360, i.e. for slabs with vapor sensitive coverings, the location of the vapor barrier should always be in direct contact with the slab¹.

¹ ACI 302.1R-96

The membrane is loose laid onto the prepared sub-base, forming overlaps that can be either mechanically secured or taped. The unique bond of Florprufe to concrete provides continuity of vapor protection at laps. Alternatively, if a taped system is preferred, self-adhered Preprufe® Tape can be used to overband the laps.

Slab reinforcement and concrete can be placed immediately. Once the concrete is poured, an integral bond develops between the concrete and membrane.

Installation

Health & Safety

Refer to relevant Material Safety Data Sheet. Complete rolls should be handled by 2 persons.

Florprufe 120 can be applied at temperatures of 25°F (-4°C) or above. Membrane installation is unaffected by wet weather. Installation and detailing of Florprufe 120 are generally in accordance with ASTM E1643-98.

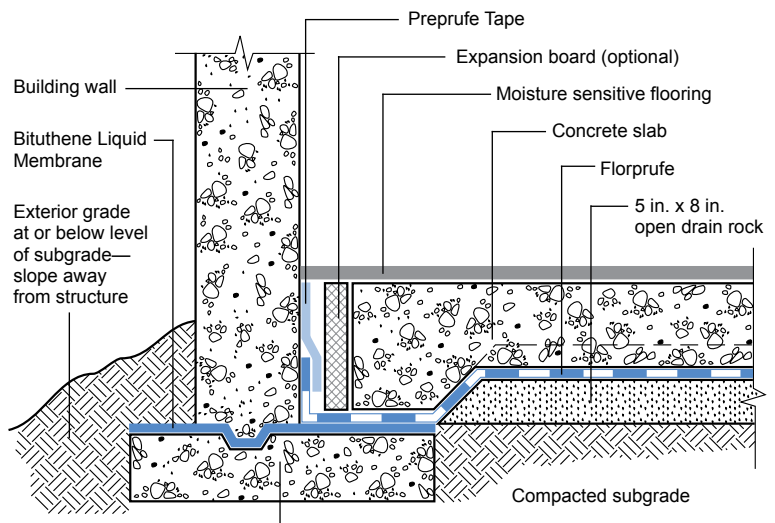

Product Advantages

- Forms a powerful integral seal
- Protects valuable floor finishes
- Ultra low vapor permeability
- Durable, chemical resistant
- Lightweight and easy to apply

Supply

Florprufe 120	
Supplied in rolls	4 ft x 115 ft (1.2 m x 35 m)
Roll area	460 ft ² (42 m ²)
Roll weight	70 lbs (32 kg) approx.
Ancillary Products	
Preprufe Tape is packaged in cartons containing 4 rolls that are 4 in. x 49 ft (100 mm x 15 m).	
Bituthene Liquid Membrane is supplied in 1.5 gal (5.7 L) pails.	

Physical Properties: Exceeds ASTM E1745 Class A rating

Property	Typical Value	Test Method
Color	White	
Thickness (nominal)	0.021 in. (0.5 mm)	ASTM D3767—method A
Water vapor permeance	0.03 perms	ASTM E96—method B1
Tensile strength	65 lbs/in.	ASTM E1541
Elongation	300%	ASTM D412
Puncture resistance	3300 gms	ASTM D17091
Peel adhesion to concrete	>4 lbs/in.	ASTM D903

1. Test methods that comprise ASTM E1745 standard for vapor retarders

Prepare substrate in accordance with ACI 302.1R Section 4.1. Install Florprufe 120 over the leveled and compacted base. Place the membrane with the smooth side down and the plastic release liner side up facing towards the concrete slab. Remove and discard plastic release liner. End laps should be staggered to avoid a build up of layers. Succeeding sheets should be accurately positioned to overlap the previous sheet 2 in. (50 mm) along the marked lap line.

Laps

1. Mechanical fastening method—

To prevent the membrane from moving and gaps opening, the laps should be fastened together at 39 in. (1.0 m) maximum centers. Fix through the center of the lap area using 0.5 in. (12 mm) long washer-head, self-tapping, galvanized screws (or similar) and allowing the head of the screw to bed into the adhesive compound to self-seal. It is not necessary to fix the membrane to the substrate, only to itself. Ensure the membrane lays flat and no openings occur. (See Figure 1.) Additional fastening may be required at corners, details, etc. Continuity is achieved once the slab is poured and the bond to concrete develops.

OR

2. Taped lap method—

For additional security use Grace Preprufe Tape to secure and seal the overlaps. Overband the lap with the 4 in. (100 mm) wide Preprufe Tape, using the lap line for alignment. Remove plastic release liner to ensure bond to concrete.

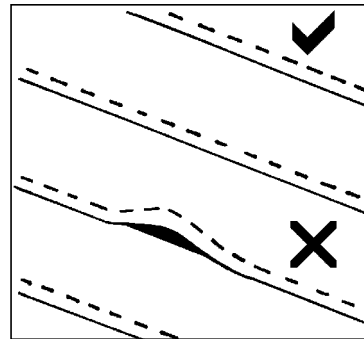

Figure 1

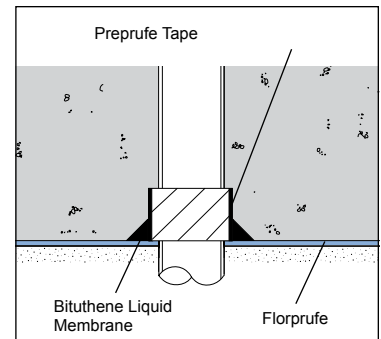

Figure 2

Penetrations

Mix and apply Bituthene Liquid Membrane detailing compound to seal around penetrations such as drainage pipes, etc. (See Figure 2 and refer to the Bituthene Liquid Membrane data sheet, BIT-230.)

Concrete Placement

Place concrete within 30 days. Inspect membrane and repair any damage with patches of Preprufe Tape. Ensure all liner is removed from membrane and tape before concreting.

www.graceconstruction.com

For technical assistance call toll free at 866-333-3SBM (3726)

Florprufe and Preprufe are registered trademarks of W. R. Grace & Co.—Conn.

We hope the information here will be helpful. It is based on data and knowledge considered to be true and accurate and is offered for the users' consideration, investigation and verification, but we do not warrant the results to be obtained. Please read all statements, recommendations or suggestions in conjunction with our conditions of sale, which apply to all goods supplied by us. No statement, recommendation or suggestion is intended for any use which would infringe any patent or copyright. W. R. Grace & Co.—Conn., 62 Whittemore Avenue, Cambridge, MA 02140. In Canada, Grace Canada, Inc., 294 Clements Road, West, Ajax, Ontario, Canada L1S 3C6.

This product may be covered by patents or patents pending.
PF-001H Printed in U.S.A. 05/14

Copyright 2014. W. R. Grace & Co.—Conn.
GCS/PDF

GRACE

PERM-A-BARRIER® PRIMER PLUS

Water-based primer for use with Perm-A-Barrier membranes

Description

Perm-A-Barrier® Primer Plus is a water-based primer which imparts an aggressive, high tack finish on the treated substrate. It is specifically designed to facilitate tenacious adhesion of Perm-A-Barrier self-adhered membranes to various substrates including plywood, oriented strand board (OSB), concrete masonry units (CMU) and glass faced wall boards.

Advantages

- **Excellent adhesion**—bonds to substrate and remains permanently pressure sensitive
- **Aggressive tack**—provides a tenacious bond to substrates such as plywood, OSB, CMU and glass faced wall boards
- **Fast drying**—increased flexibility for application schedule
- **Fast and easy application**—by brush or roller
- **VOC compliant**—water-based, contains no hazardous or flammable solvents
- **Low odor**—no noxious fumes

Use

Perm-A-Barrier Primer Plus can be used at 40°F (5°C) or above.

Availability

Perm-A-Barrier Primer Plus is available in 5 gallon plastic pails.

Installation

Safety, Storage and Handling Information

Perm-A-Barrier Primer Plus is nonflammable in the wet state. Material Safety Data Sheets (MSDS) are available at graceconstruction.com, and users should acquaint themselves with this information. Carefully read detailed precaution statements on product labels and the MSDS before use.

The VOC (Volatile Organic Compound) content is <1 g/L, and it meets the U.S. EPA Volatile Organic Compound Emission Standard for Architectural Coatings.

Architectural and Industrial Maintenance Regulations limit the VOC content in products classified as Architectural Coatings. Refer to Technical Letters at graceconstruction.com for most current list of allowable limits.

It is important that Perm-A-Barrier Primer Plus be protected from freezing. Best storage temperature is 60–80°F (15–27°C). Higher temperatures reduce normal storage life. Lower temperatures can cause increased viscosity of a temporary nature. This primer will become unusable with prolonged storage below 40°F (4°C). Rotate stock on a “first in, first out” basis.

When stored at recommended temperature in the original, unopened container, this product has a shelf life of 15 months from date of shipment.

Surface Preparation

All surfaces must be free from frost, dirt, grease, oil or other contaminants. Failure to remove excessive dust may result in compromised adhesion of the membrane.

Product Advantages

- Excellent adhesion
- Aggressive tack
- Fast drying
- Quick and easy application
- VOC compliant
- Low odor

Application

Apply primer in dry weather with ambient and substrate temperatures above 40°F (5°C). Surface must be dry and clean. Perm-A-Barrier Primer Plus can be applied by brush or roller. Typical brushes and rollers designed for use with latex paints may be used.

Coverage

Approximately 450-500 ft²/gal (11-12 m²/L) on glass-mat faced gypsum sheathing such as DensGlass® Gold. Coverage rates may vary depending on substrate type, brand and roughness.

Drying

Allow Perm-A-Barrier Primer Plus to dry until surface becomes tacky. Drying times may vary depending on temperature and humidity conditions.

The product is packaged “ready to use.”
Do not use any substance to thin this product.
Protect from freezing.

Cleanup

Wet adhesive may be removed using soapy water. For dry primer, citrus based cleaners may be used.

www.graceconstruction.com

For technical assistance call toll free at 866-333-3SBM (3726)

Perm-A-Barrier is a trademark of W. R. Grace & Co.—Conn. registered in the United States and other countries.

DensGlass is a registered trademark of Georgia-Pacific Gypsum, LLC., Securock is a registered trademark of USG Corporation

We hope the information here will be helpful. It is based on data and knowledge considered to be true and accurate and is offered for the users' consideration, investigation and verification, but we do not warrant the results to be obtained. Please read all statements, recommendations or suggestions in conjunction with our conditions of sale, which apply to all goods supplied by us. No statement, recommendation or suggestion is intended for any use which would infringe any patent or copyright. W. R. Grace & Co.—Conn., 62 Whittemore Avenue, Cambridge, MA 02140. In Canada, Grace Canada, Inc., 294 Clements Road, West, Ajax, Ontario, Canada L1S 3C6.

This product may be covered by patents or patents pending.
PAB-101E Printed in U.S.A. 08/14

Copyright 2011. W. R. Grace & Co.—Conn.
GCS/PDF

GRACE

PERM-A-BARRIER® WB PRIMER

Water-based primer for use with Perm-A-Barrier Flashings, Detail Membrane and Wall Membrane

Description

Perm-A-Barrier® WB Primer is a water-based primer which imparts an aggressive, high tack finish on the treated substrate. It is specifically designed to facilitate tenacious adhesion of Perm-A-Barrier Flashings, Perm-A-Barrier Detail Membrane and Perm-A-Barrier Wall Membrane to various substrate including glass-mat faced gypsum sheathing. Refer to Technical Letter 2, *Substrate Preparation for Application of Perm-A-Barrier Products to Glass-Mat Faced Gypsum Sheathing* for priming requirements on specific glass-mat faced sheathing products.

Advantages

- **Excellent adhesion**—bonds to substrate and binds dust
- **Aggressive tack**—provides a tenacious bond to difficult substrates such as DensGlass Gold and other glass faced wall boards
- **Fast drying**—increased flexibility for application schedule
- **Fast and easy application**—by brush or roller
- **VOC compliant**—water-based, contains no hazardous or flammable solvents
- **Low odor**—no noxious fumes

Use

Perm-A-Barrier WB Primer can be used at 25°F (-4°C) or above. It will freeze at 21°F (-7°C) and can no longer be used after it freezes.

Availability

Perm-A-Barrier WB Primer is available in 1 gallon jugs and 5 gallon plastic pails.

Installation

Safety, Storage and Handling Information

Perm-A-Barrier WB Primer is nonflammable. Material Safety Data Sheets (MSDS) are available at graceconstruction.com and users should acquaint themselves with this information. Carefully read detailed precaution statements on product labels and the MSDS before use.

Store above freezing 32°F (0°C).

The VOC (Volatile Organic Compound) content is 10 g/L and it meets the U.S. EPA Volatile Organic Compound Emission Standard for Architectural Coatings.

Architectural and Industrial Maintenance Regulations limit the VOC content in products classified as Architectural Coatings. Refer to Technical Letters at graceconstruction.com for most current list of allowable limits.

Product Advantages

- Excellent adhesion
- Aggressive tack
- Fast drying
- Fast and easy application
- VOC compliant
- Low odor

Application

Apply primer in dry weather with ambient and substrate temperatures above 25°F (-4°C). Surface must be dry and clean.

Surface Preparation

All surfaces must be free from frost, dirt, grease, oil or other contaminants. Failure to remove excessive dust may result in compromised adhesion of the membrane.

In cooler or humid conditions, priming may be done in advance. If primed surface is exposed for more than 7 days, or if significant dust or dirt accumulates on the surface, re-prime with a thin coat of Perm-A-Barrier WB Primer.

Roller Technique

Synthetic, ½ in. (13 mm), nap rollers have been found to be very successful for the application of Perm-A-Barrier WB Primer. A moderately thick coating should be applied and rolled out evenly (see coverage below). A properly applied coating will have uniform coverage and leave a tacky finish to the surface when dry.

Coverage

250–350 ft²/gal (6.0–8.0 m²/L)

Drying Time

To be effective, the Perm-A-Barrier WB Primer needs to fully dry. Drying time of the material is dependent on many factors including temperature, humidity, wind, sunlight and coverage rate. The drying time could vary from as little as 15 min. (warm and windy) to 3 hours (cold and no wind), depending on the weather condition. The following are guidelines for dry time at various temperatures:

- 90°F (32°C) or greater:
45 min.–1 hr
- 50°F (10°C) to 90°F (32°C):
1–3 hrs
- Less than 50°F (10°C):
3 hrs +

The product is packaged “ready to use.” Do not use any substance to thin this product.

www.graceconstruction.com

For technical assistance call toll free at 866-333-3SBM (3726)

Perm-A-Barrier and Vycor are registered trademarks of W. R. Grace & Co.–Conn.
DensGlass Gold is a registered trademark of Georgia-Pacific Corporation.

We hope the information here will be helpful. It is based on data and knowledge considered to be true and accurate and is offered for the users' consideration, investigation and verification, but we do not warrant the results to be obtained. Please read all statements, recommendations or suggestions in conjunction with our conditions of sale, which apply to all goods supplied by us. No statement, recommendation or suggestion is intended for any use which would infringe any patent or copyright. W. R. Grace & Co.–Conn., 62 Whittemore Avenue, Cambridge, MA 02140. In Canada, Grace Canada, Inc., 294 Clements Road, West, Ajax, Ontario, Canada L1S 3C6.

This product may be covered by patents or patents pending.
PAB-020H Printed in U.S.A. 08/14

Copyright 2014. W. R. Grace & Co.–Conn.
GCS/PDF

GRACE

Don't just build it... Protect it!



www.graceresidential.com

For technical assistance call toll free at 866-333-3SBM (3726)

We hope the information here will be helpful. It is based on data and knowledge considered to be true and accurate and is offered for the users' consideration, investigation and verification, but we do not warrant the results to be obtained. Please read all statements, recommendations or suggestions in conjunction with our conditions of sale, which apply to all goods supplied by us. No statement, recommendation or suggestion is intended for any use which would infringe any patent or copyright. W. R. Grace & Co.-Conn., 62 Whittemore Avenue, Cambridge, MA 02140. In Canada, Grace Canada, Inc., 294 Clements Road, West, Ajax, Ontario, Canada L1S 3C6.

This product may be covered by patents or patents pending.
WPS-002A Printed in U.S.A. 12/14

Copyright 2014. W. R. Grace & Co.-Conn.
GCS/PDF

GRACE