



Green Wall System

ARCH 2430

Jonathan Ramirez
Farhana Rahman
Renee fayzimatova
Micheal Dicarlo

Air barriers and sealants

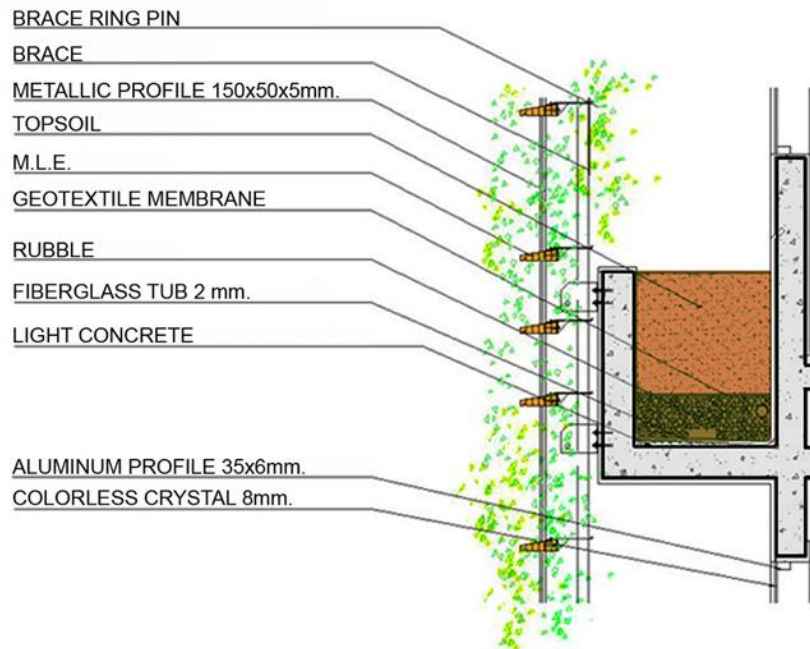

- ▶ A wide variety of materials make good air barriers, including poured concrete, glass, drywall, rigid foam insulation, plywood, OSB, and peel-and-stick rubber membrane.
- ▶ To make a good air barrier, a material not only needs to stop air flow; it also needs to be relatively rigid and durable. If you want to determine whether a material is an air barrier, hold a piece of the material up to your mouth and blow. If you can blow air through it, it's not an air barrier.

Air barriers and sealants

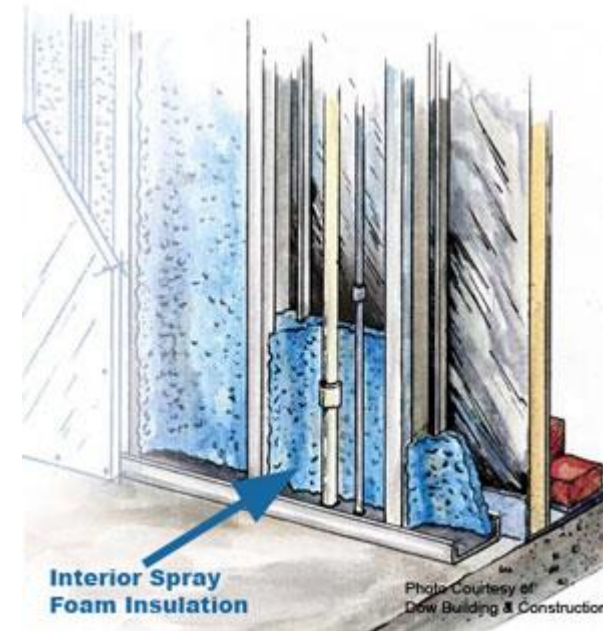
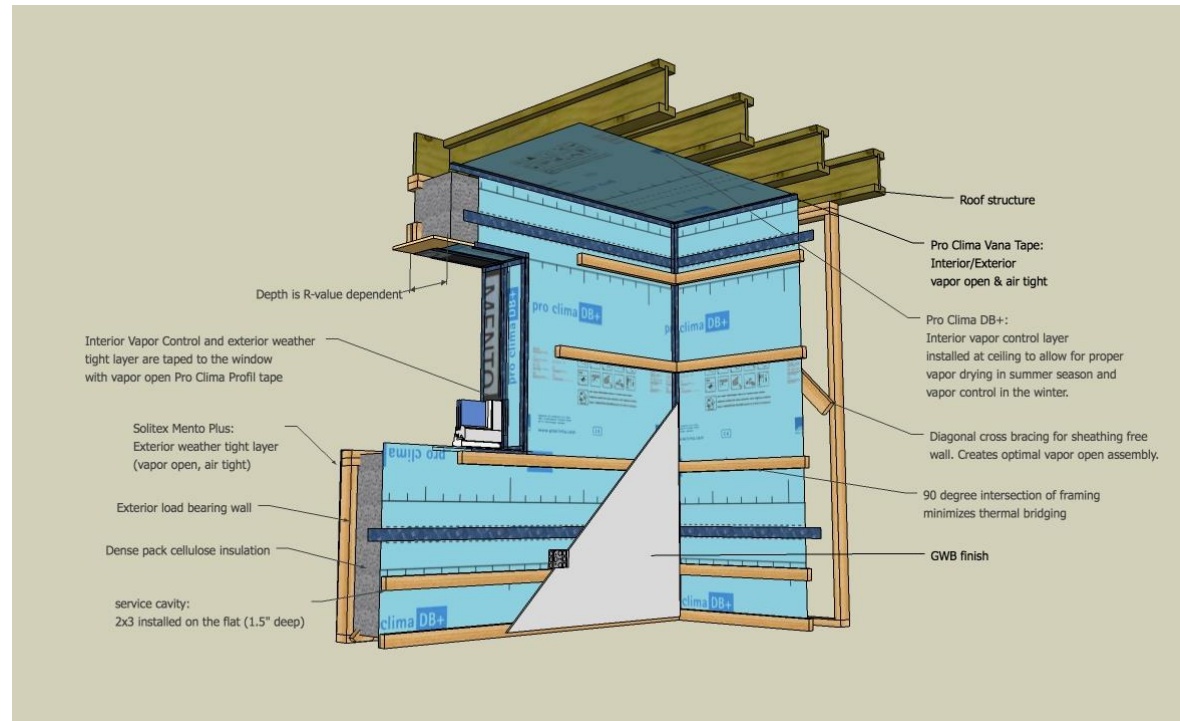

Attachment systems and fire safety

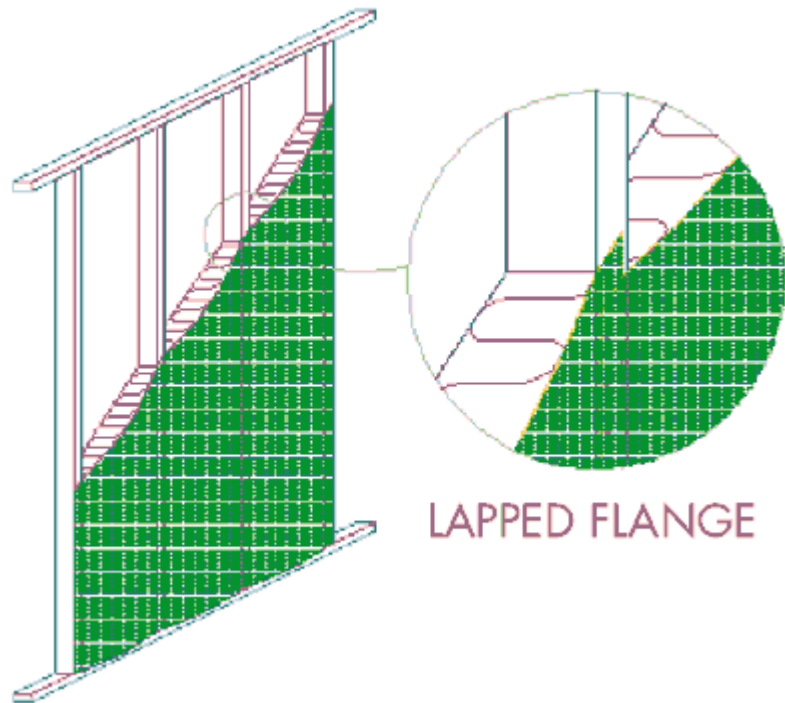

- ▶ Carl Stahl DécorCable is proud to offer a comprehensive range of cable, rod, and mesh systems for architectural, structural and interior design applications. Our visual display products are widely used in graphics, product display, exhibits, and corporate identity.

Attachment systems and fire safety



- ▶ Firewalls can be used to subdivide a building into separate fire areas and are located in accordance with the locally applicable building code. Firewalls are a portion of a building's passive fire protection systems.
- ▶ Firewalls can be used to separate high value transformers at an electrical substation in the event of a mineral oil tank rupture and ignition. The firewall serves as a fire containment wall between one oil-filled transformer and other neighboring transformers, building structures, and site equipment.

Case study buildings



Project Name: CaixaForum Madrid

Construction year: 2007

Architect(s): Herzog & de Meuron

Project Category: Public

Address: Paseo del Prado 36, Madrid

there is a green wall designed by French botanist Patrick Blanc..

Case study buildings

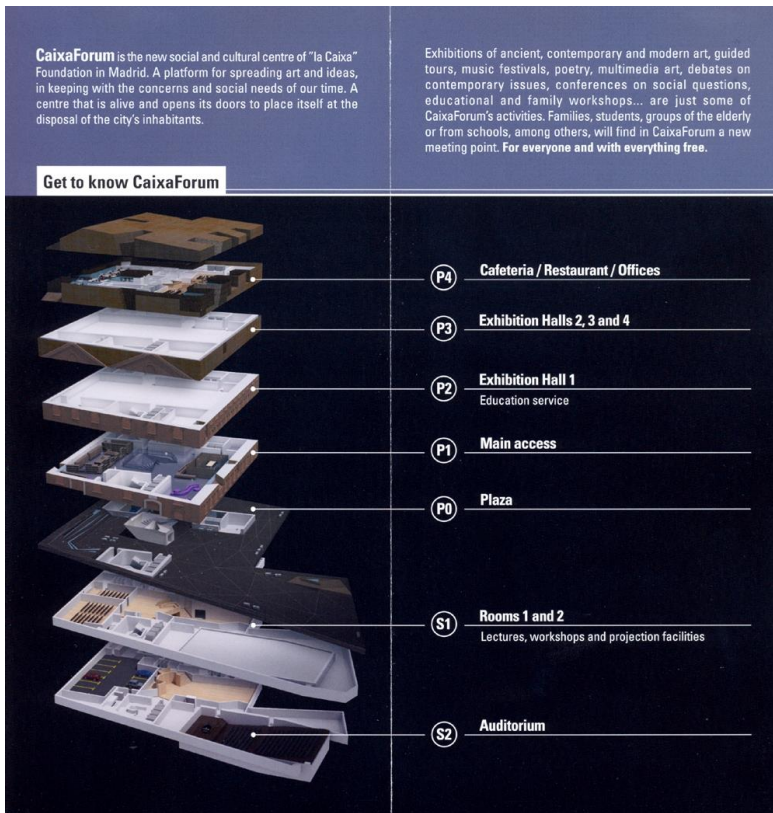

- CaixaForum Madrid is a museum and cultural center.
- it's the most visited museum in Madrid.
- The façade of the building bring out the museum which bring more visitors.

Rain penetration and moisture control

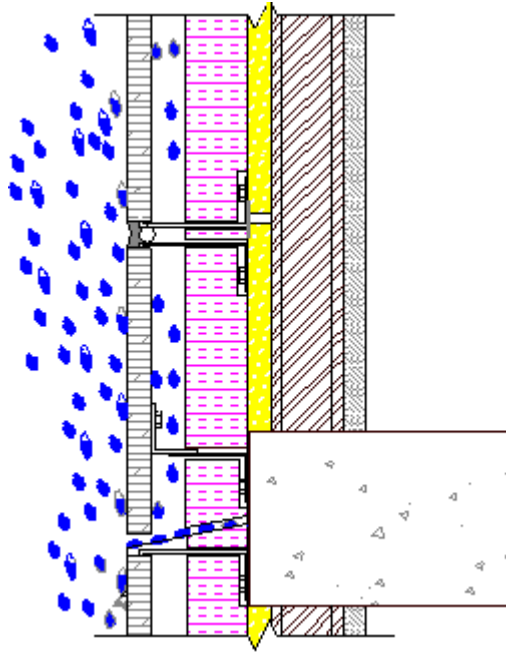

Keep all untreated wood materials away from earth contact.

Install well-designed guttering and downspouts connected to a drainage system that diverts rainwater completely away from the house.

Slope the earth away from all sides of the house for at least 5 feet at a minimum 5% grade (3 inches in 5 feet). Establish drainage swales to direct rainwater around and away from the house. Add a gasket under the sill plate to provide air sealing.

Install a protective membrane, such as rubberized roofing or ice-dam protection materials, between the foundation and the sill plate to serve as a capillary break and reduce wicking of water up from the masonry foundation wall. This membrane can also serve as a termite shield on top of foam board insulation.

Damp-proof all below-grade portions of the foundation wall and footing to prevent the wall from absorbing ground moisture by capillary action.

Place a continuous drainage plane over the damp-proofing or exterior insulation to channel water to the foundation drain and relieve hydrostatic pressure. Drainage plane materials include special drainage mats, high-density fiberglass insulation products, and washed gravel. All drainage planes should be protected with a filter fabric to prevent dirt from clogging the intentional gaps in the drainage material.

Install a foundation drain directly below the drainage plane and beside (not on top of) the footing. This prevents water from flowing against the seam between the footing and the foundation wall. Surround a perforated 4-inch plastic drainpipe with gravel and wrap both with filter fabric.

Underneath the basement or on-grade slab floor, install a capillary break and vapor diffusion retarder, consisting of a layer of 6- to 10-mil polyethylene over at least 4 inches of gravel.

System joints and connections

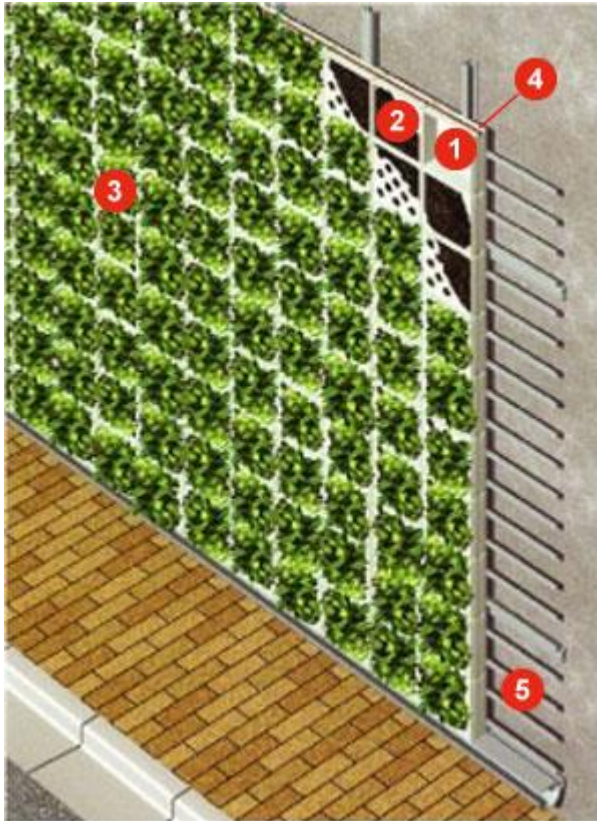

Pro Wall System

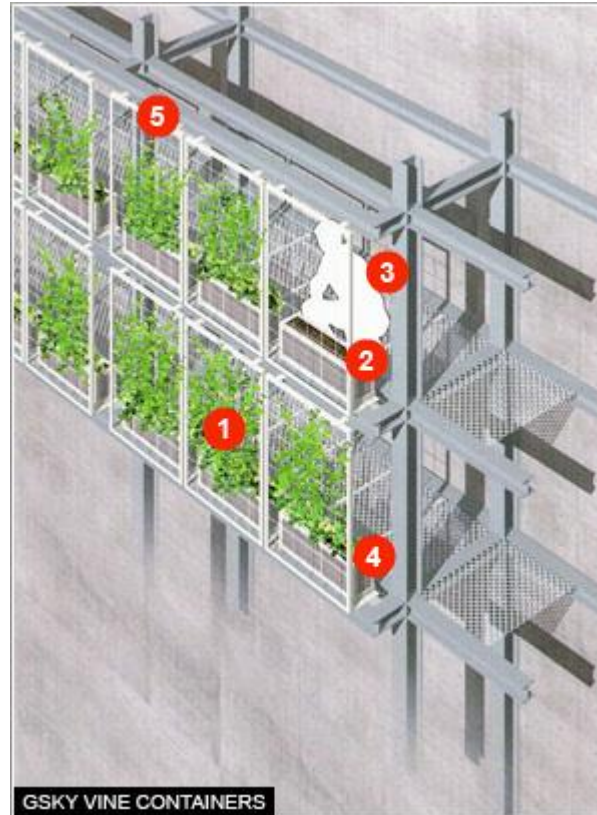

Basic Wall System

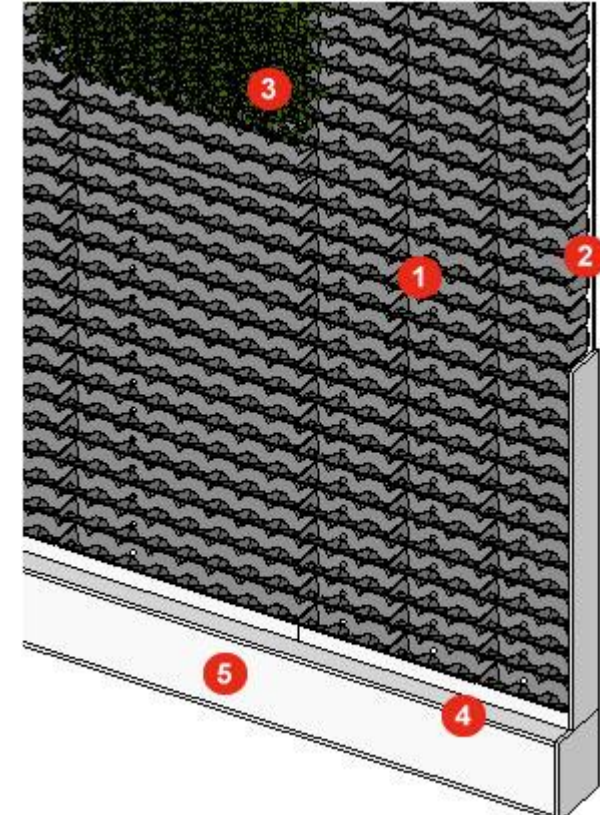

Versa Wall System

Thermal insulation and R value

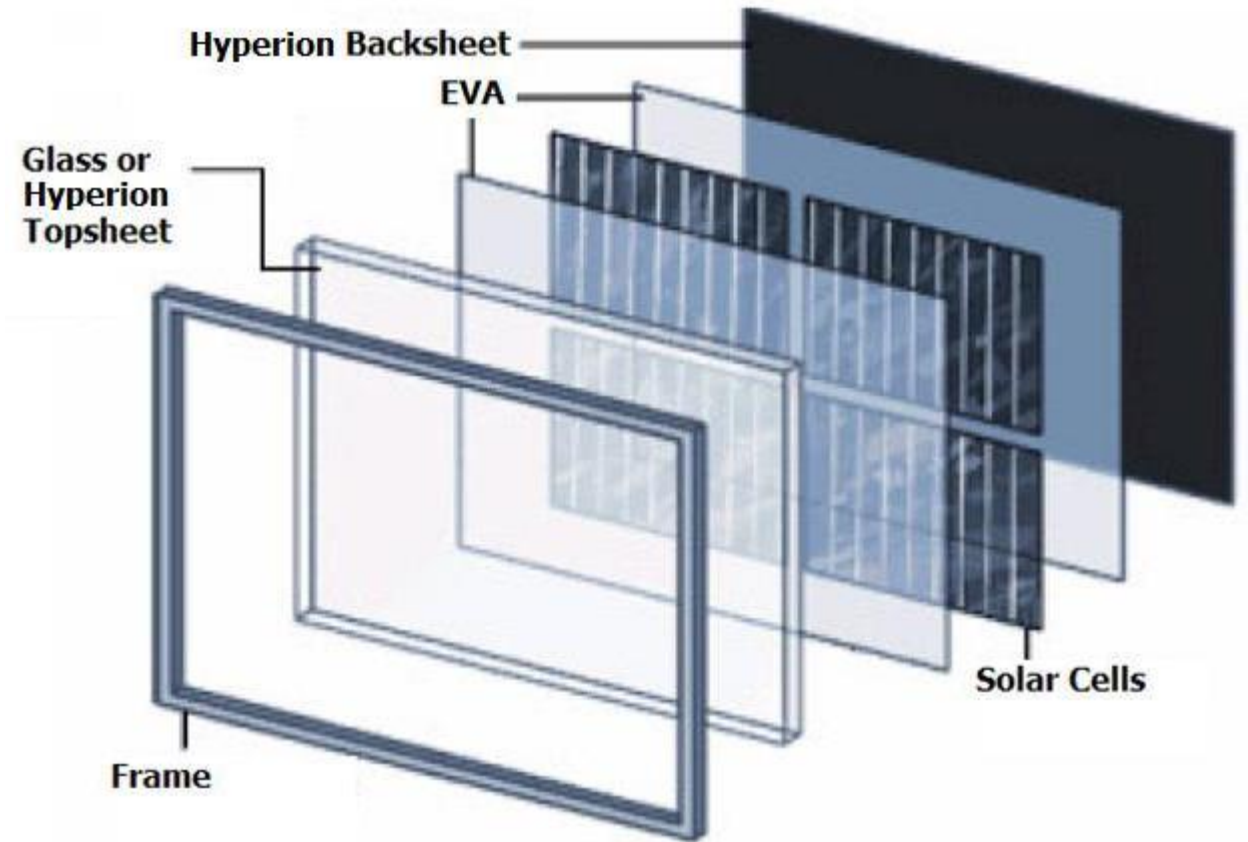
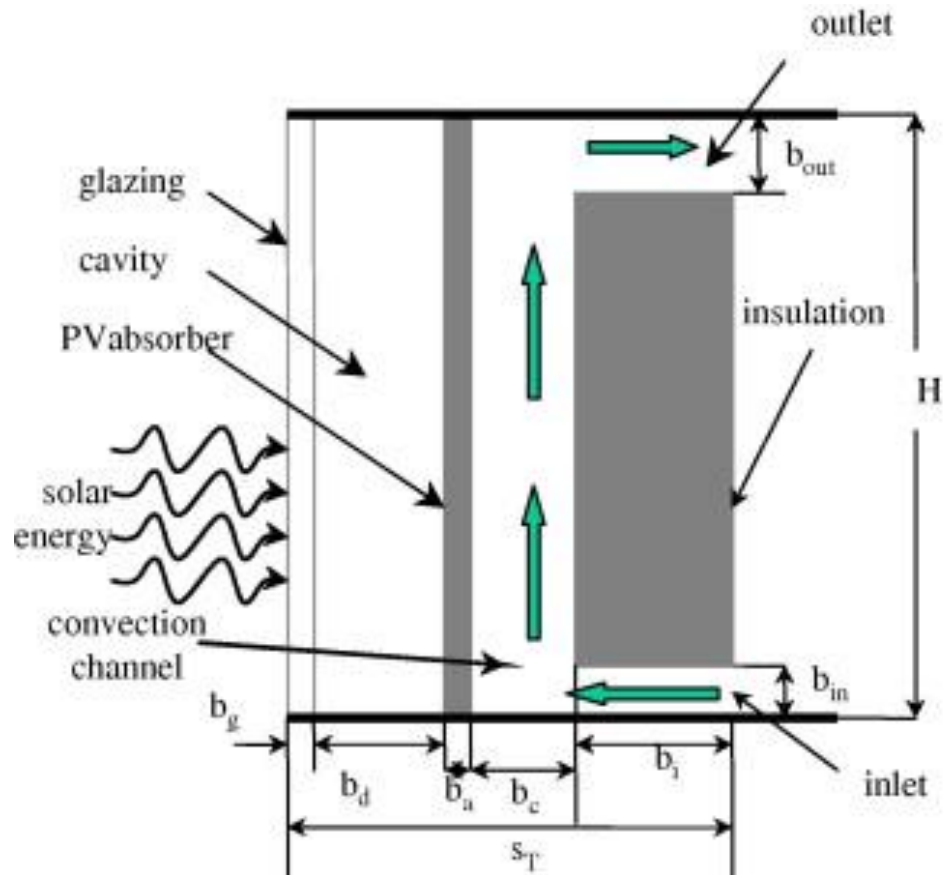

Thermal insulation and R value

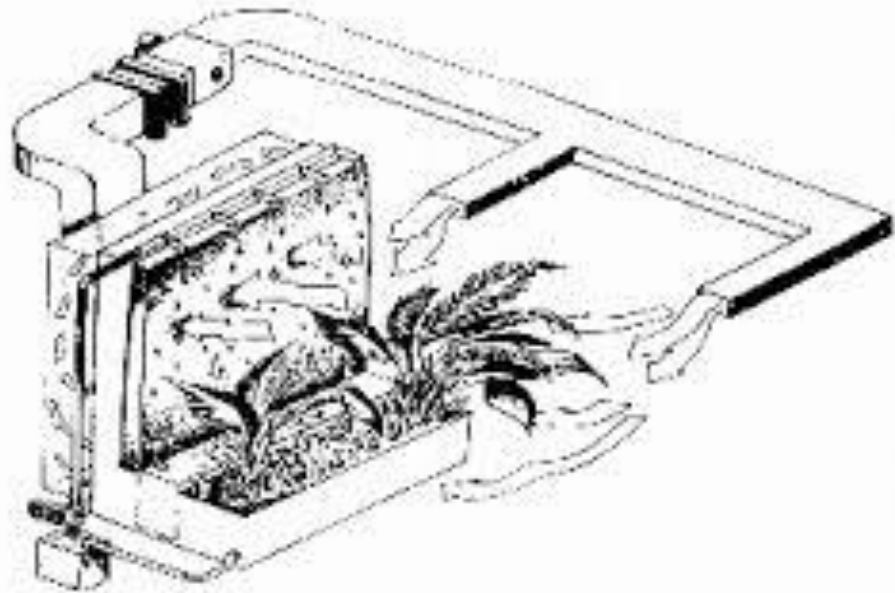

- ▶ Improves thermal insulation capacity through external temperature regulation. The extent of the savings depends on various factors such as climate, distance from sides of buildings, building envelope type, and density of plant coverage. This can impact both the cooling and heating

Historical systems- comparison

- ▶ **3rd C. BCE to 17th C. AD:** Throughout the Mediterranean, Romans train grape vines (*Vitis* species) on garden trellises and on villa walls. Manors and castles with climbing roses are symbols of secret gardens.
- ▶ **1920s:** The British and North American garden city movement promote the integration of house and garden through features such as pergolas, trellis structures and self-clinging climbing plants.
- ▶ **1988:** Introduction of a stainless steel cable system for green facades.
- ▶ ***Hanging Gardens of Babylon***
- ▶ Source: *Hand colored engraving, Maarten van Heemskerck, Dutch*
- ▶ *Green Roofs for Healthy Cities: Introduction to Green Walls – www.greenroofs.org 4*
- ▶ **Early 1990s:** Cable and wire-rope net systems and modular trellis panel systems enter the North American marketplace.
- ▶ **1993:** First major application of a trellis panel system at Universal CityWalk in California.
- ▶ **1994:** Indoor living wall with bio-filtration system installed in Canada Life Building in Toronto, Canada.

- ▶ **2002:** The MFO Park, a multi-tiered 300' long and 50' high park structure opened in Zurich, Switzerland. The project featured over 1,300 climbing plants.
- ▶ **2005:** The Japanese federal government sponsored a massive Bio Lung exhibit, the centerpiece of Expo 2005 in Aichi, Japan. The wall is comprised of 30 different modular green wall systems available in Japan.
- ▶ **2007:** Seattle implements the Green Factor, which includes green walls.
- ▶ **2007:** GRHC launches full day Green Wall Design 101 course; the first on the subject in North America.
- ▶ **2008:** GRHC launches Green Wall Award of Excellence and Green Wall Research Fund.



Historical systems- comparison

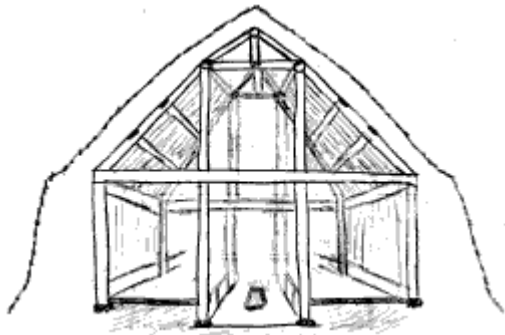
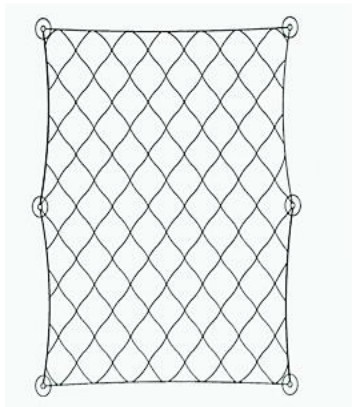
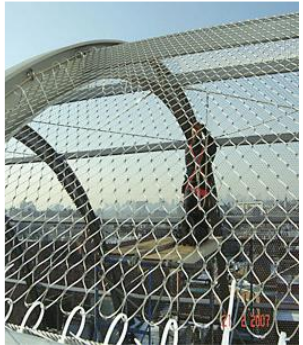

Construction time and cost

- ▶ Project size.
- ▶ Design team costs.
- ▶ System type.
- ▶ Support structure requirements.
- ▶ Building location.
- ▶ Complexity of design, use of standard or custom components.
- ▶ Site conditions and access.
- ▶ Cost of installation labor.
- ▶ Local availability of materials.
- ▶ Project timeline.
- ▶ Type of plants used.
- ▶ Short and long term maintenance.



171 Broadway Restaurant (Modular Living Wall)

Location: NYC

New construction or retrofit: Retro

Date of implementation: Oct 2007

Size: 300 sq.ft.

Cost: \$110 per sq.ft.

Green wall system:

Plants used:

Pothos

Climbing jade

Philodendren

Aglonema

Green Living™ Wall system, Standard 2'x

2'x 3" depth

Structural support system:

Custom GLT mounting Brackets

Internal options- connections and finishes



Pennsylvania, Longwood interior expansion of their East Conservatory

Landscape architect, Kim Wilke, and installed by Ambius' Special Projects team led by Denise Eichmann



The 4,072 sq ft green wall at Longwood Gardens surpassed the previous longest green wall in North America by 1,210 sq ft.



Environmental implications/ sustainability

Benefits include (but are not limited to):

- ▶ Air quality improvement
- ▶ Heat Island effect reduction
- ▶ Internal building temperature control
- ▶ Acoustic insulation
- ▶ Heat retention
- ▶ Water retention, filtration and management
- ▶ Increases the biodiversity of the city
- ▶ Stress reduction (health improvement)
- ▶ aesthetic



Sky Farm in downtown Toronto, Canada

- 58 story building
- requires 1.32 hectares of land
- will have 8 million square foot of agricultural space
- crops could yield up to \$23 million in yearly revenue



External architectural finishes and durability

- ▶ Buildings are exposed to the weathering elements and over time some of the organic construction materials may begin to break down, as a result of contraction and expansion shifts due to freeze-thaw cycles and UV exposure.
- ▶ Protects exterior finishes from UV radiation, the elements, and temperature fluctuations that wear down materials.
- ▶ May benefit the seal or air tightness of doors, windows, and cladding by decreasing the effect of wind pressure.



Green roofs typically last longer than conventional ones. A conventional roof might last 20 years, while a green roof will survive 40 to 50 years. That's because the plants and soil protect the waterproofing from ultraviolet rays and temperature fluctuations that cause cracks.



Construction details

DRAWING TITLE:
GSKY GREEN WALL PANELS
CONCRETE WALL STRUCTURE / INTERIOR OR EXTERIOR
 3D VIEW SECTION DETAIL FASTENER DETAIL
 PLAN DETAIL

DRAWING #
1-p

DATE: AUG 18, 2010 SCALE: AS NOTED
 REV DATE: N/A PAPER SIZE: 11 x 17



#704 - 318 HOMER ST
 VANCOUVER, BC V6B 2V2
 604-708-0611 ph 604-357-1315 fax
 www.gsky.com

DESIGN NOTE:
 *STRUCTURE MUST SUPPORT 30 LBS/QT SATURATED GSKY GREEN WALL SYSTEM
 *WALL SURFACE MUST BE SMOOTH
 *WATERPROOFING IS REQUIRED TO BE APPLIED (LIQUID OR SELF ADHESIVE TYPE IS RECOMMENDED)
 *ADEQUATE LIGHTING MUST BE DESIGNED AND INSTALLED (FOR INTERIOR GREEN WALL)
 *WALL MUST BE ACCESSIBLE FOR MAINTENANCE (LIFT ACCESS MAY BE REQUIRED)
 *EMBEDDED PIPE OR CONDUIT LOCATIONS MUST BE INDICATED TO GSKY
 *TRIM WIDTH MAY INCREASE DEPENDING ON LOCATION OF ZONE VALVES; SEE 9-p, 10-p AND 11-p FOR DETAIL
 *GREEN WALL BELOW MUST TO BE CLEAR FOR MAINTENANCE LIFT ACCESS

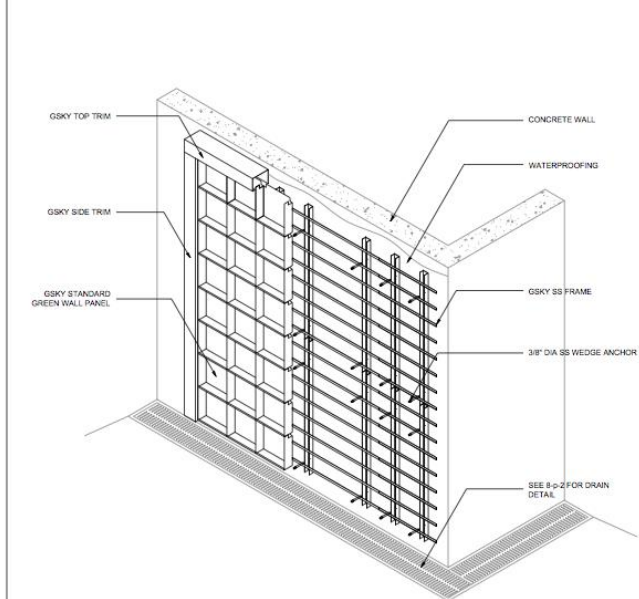

1 3D VIEW / CONCRETE WALL
 SCALE 3/4" = 1'-0" (FILE # 1-p-1)

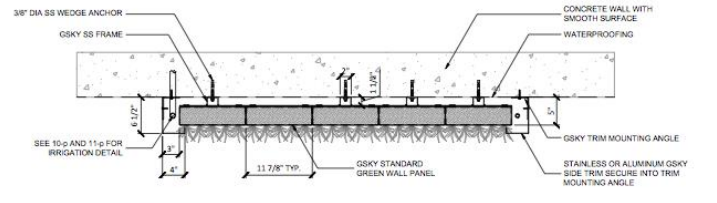

2 PLAN DETAIL / CONCRETE WALL
 SCALE 3/4" = 1'-0" (FILE # 1-p-2)

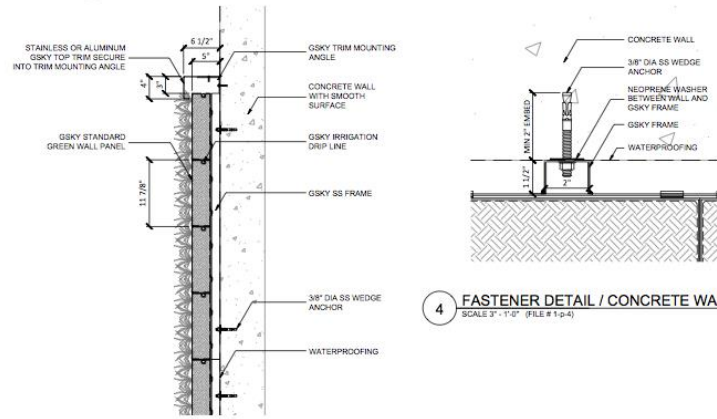

4 FASTENER DETAIL / CONCRETE WALL
 SCALE 3/4" = 1'-0" (FILE # 1-p-4)

3 SECTION DETAIL / CONCRETE WALL
 SCALE 3/4" = 1'-0" (FILE # 1-p-3)

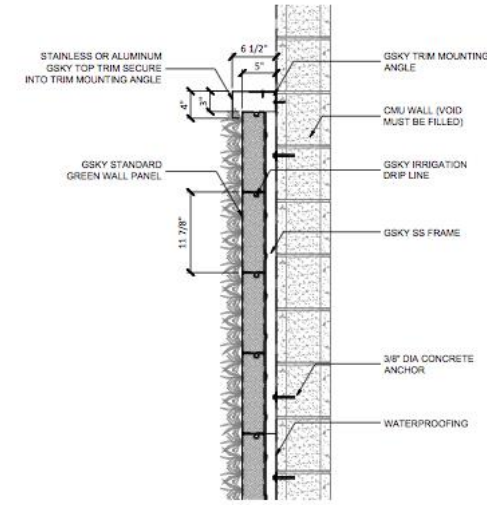

3 SECTION DETAIL / CMU WALL
 SCALE 3/4" = 1'-0" (FILE # 2-p-3)

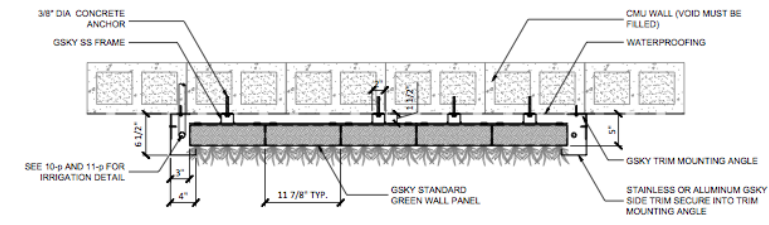

2 PLAN DETAIL / CMU WALL
 SCALE 3/4" = 1'-0" (FILE # 2-p-2)

More details

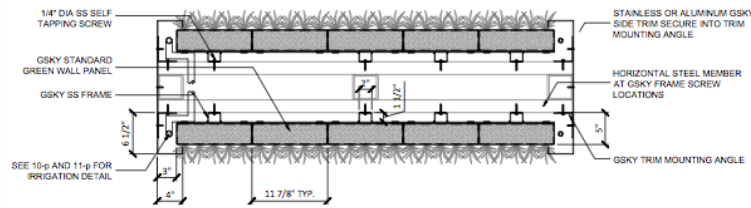
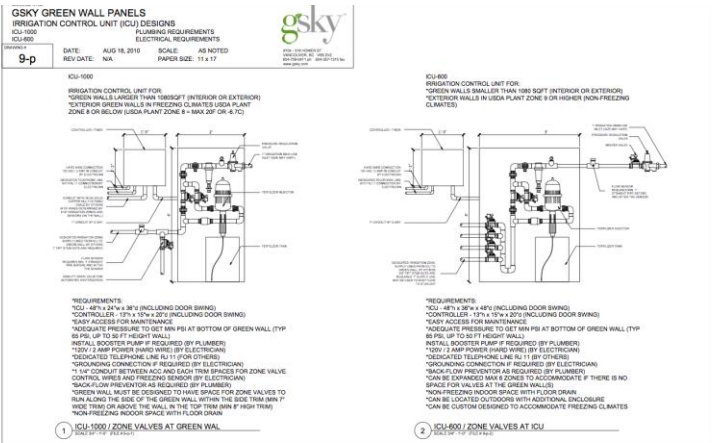
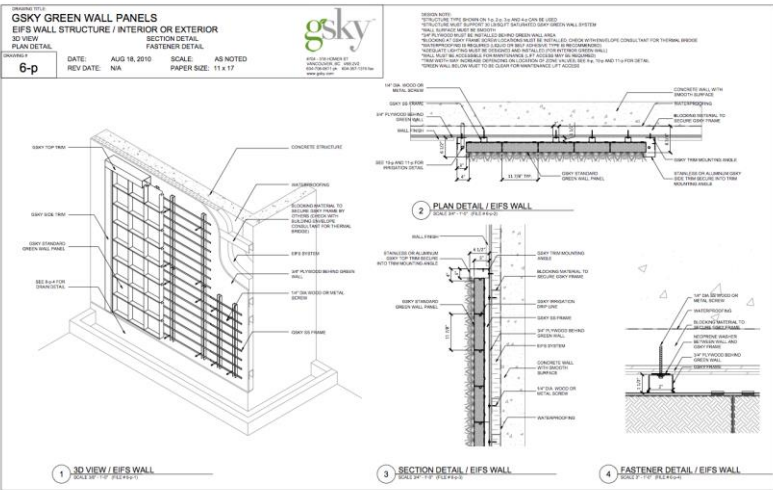

2 PLAN DETAIL / DOUBLE SIDED WALL
SCALE 3/4" = 1'-0" (FILE # 3-p-2)

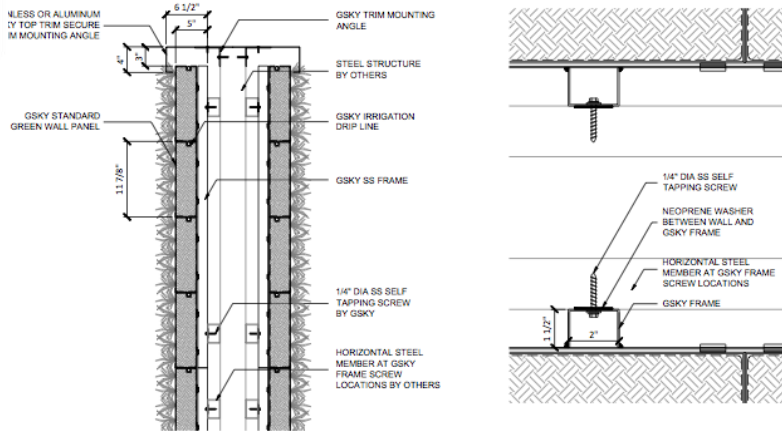

3 SECTION DETAIL / DOUBLE SIDED WALL
SCALE 3/4" = 1'-0" (FILE # 3-p-3)

4 FASTENER DETAIL / DOUBLE SIDED WALL
SCALE 3/4" = 1'-0" (FILE # 3-p-4)

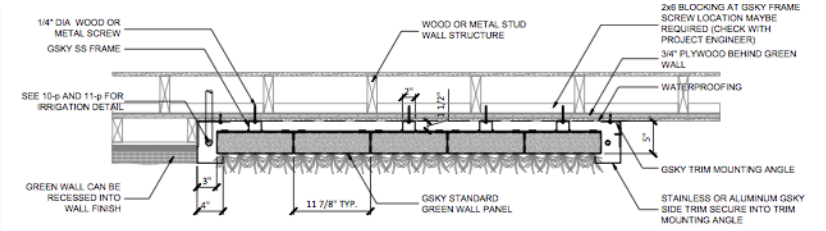

2 PLAN DETAIL / STUD WALL
SCALE 3/4" = 1'-0" (FILE # 3-p-2)

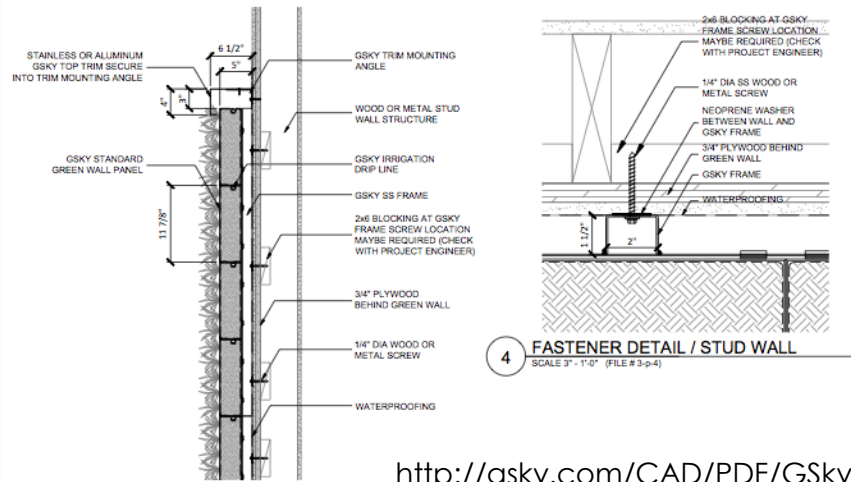

3 SECTION DETAIL / STUD WALL
SCALE 3/4" = 1'-0" (FILE # 3-p-3)

4 FASTENER DETAIL / STUD WALL
SCALE 3/4" = 1'-0" (FILE # 3-p-4)

<http://gsky.com/CAD/PDF/GSky%20Green%20Wall%20Spec%20Drawing%20Set%20V2.0.pdf>

System movement- seismic resistance

PRODUCT CATEGORIES

Gsky systems



Pro Wall System



Versa Wall System



Basic Wall System

Air barriers and sealants

The DuPont portfolio of innovative materials for photovoltaic modules

A Front Sheet Materials
DuPont® Teflon® films

B Photovoltaic Encapsulants
DuPont® PV1000 Series EVA resins
DuPont® PV5200 Series encapsulant sheets
DuPont® PV5300 Series encapsulant sheets

C Metallization Pastes
DuPont® Solamet® metallization pastes

D Thin Film Substrates
DuPont® Kapton® polyimide films
DuPont Teijin Films®

E Junction Box and Structural Support Materials
DuPont® Rynite® PET
thermoplastic polyester resins

F Back Sheet Materials
DuPont® Tedlar® PVF films
DuPont Teijin Films®

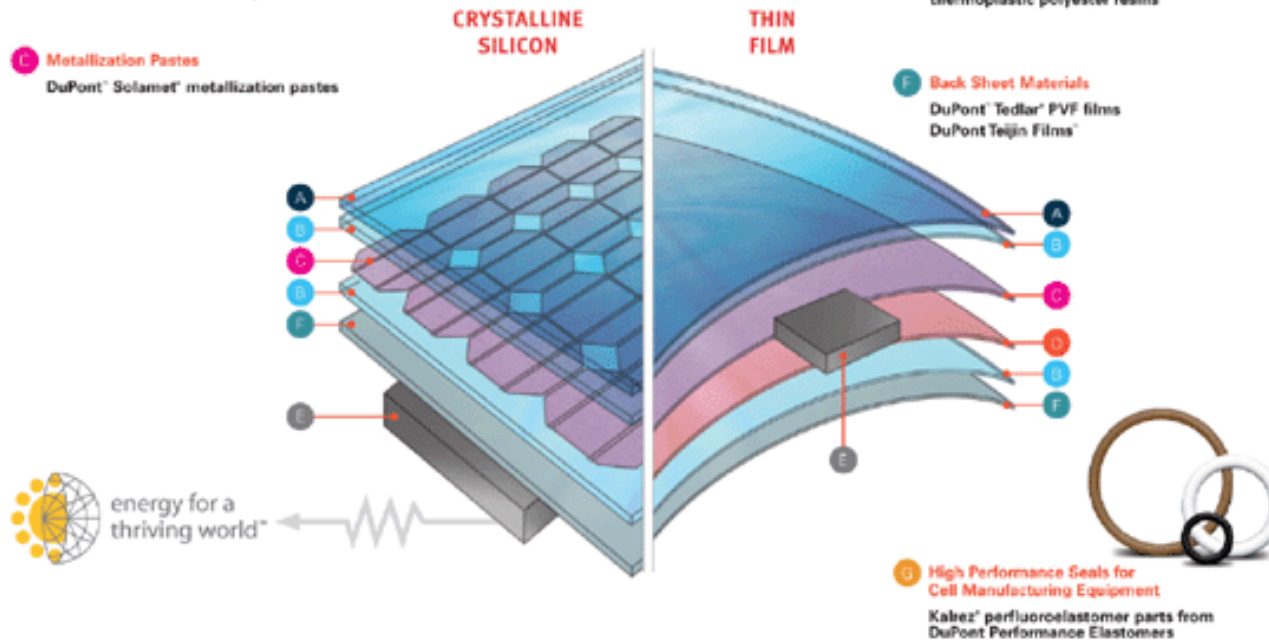

Case study buildings



- Efficient and space-saving energy generation using the building shell
- Maximum energy yield due to optimum self-cleaning and rear ventilation
- Homogeneous flush-mounted, weather-resistant PV facade
- No visible mounting components
- Small module joints
- Integrated drainage system
- Minimal installation depth of just 80 mm

Case study buildings



Black PV module specifications

Properties	
Dimensions	991 x 1656 x 6.5 mm
Glass thickness	5 mm
Glass properties	Tempered solar safety glass

Mechanical specifications	
Backsheet	anthracite
Laminate structure	Glass / EVA / cells / EVA / backsheet
Weight	approx. 23.6 kg
Cell type	156 x 156 mm monocrystalline
Cell connection	60 cells, serial
Electrical junction box	Tyco Solarlok 4-Rail with 3 bypass diodes
Electrical connection cables	Tyco Solarlok 4 mm ² , length 1 m each
Electrical connectors	Tyco Solarlok Cable Coupler: Standard Line

Temperature coefficients	
α (I_{sc})	+0.04 %/K
β (U_{oc})	-0.33 %/K
γ (P_{mpp})	-0.43 %/K

Electrical specifications	
Nominal output	250 Wp
Voltage U_{mpp}	30.5 V
Current I_{mpp}	8.2 A
Open circuit voltage U_{oc}	37.8 V
Short circuit current I_{sc}	8.8 A
Maximum system voltage	1000 V
Cell technology	monocrystalline

Active building design with photovoltaics

Thermal insulation and R value

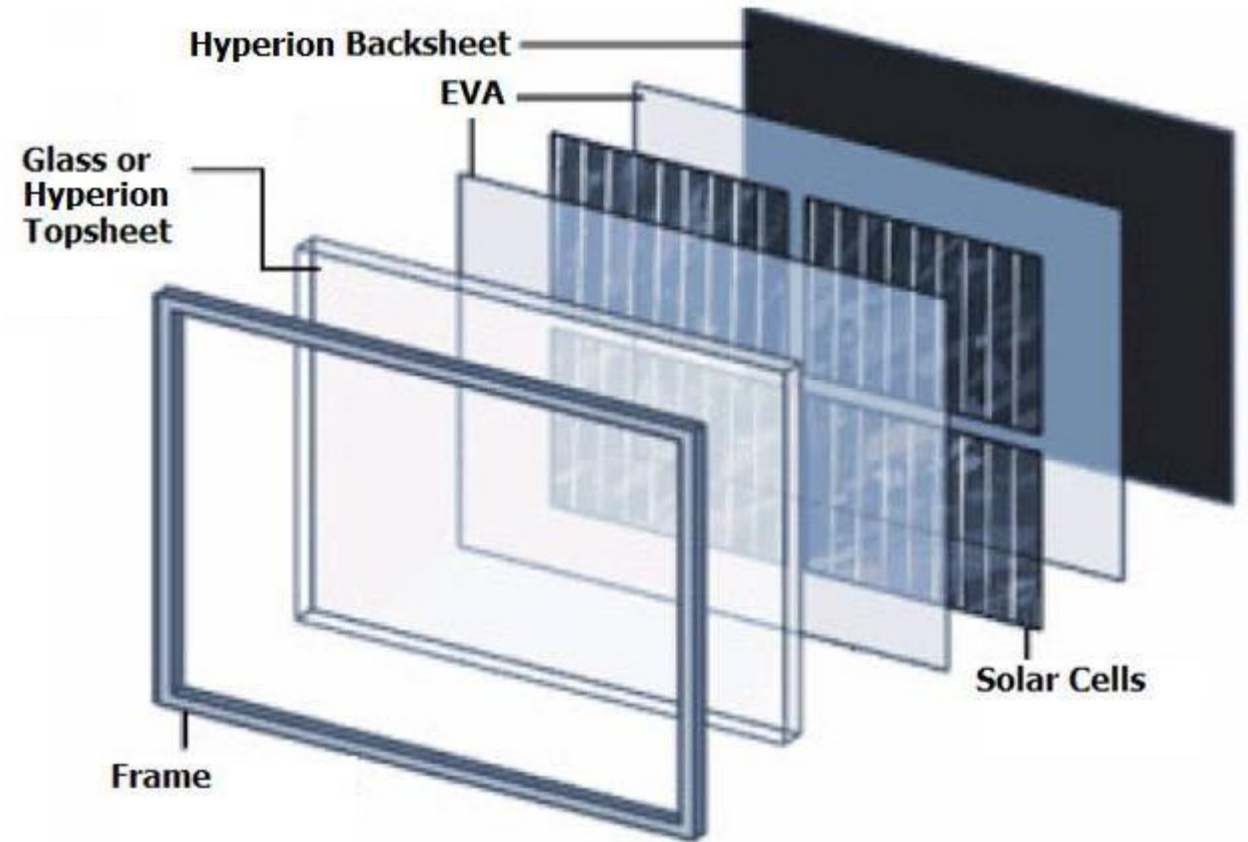
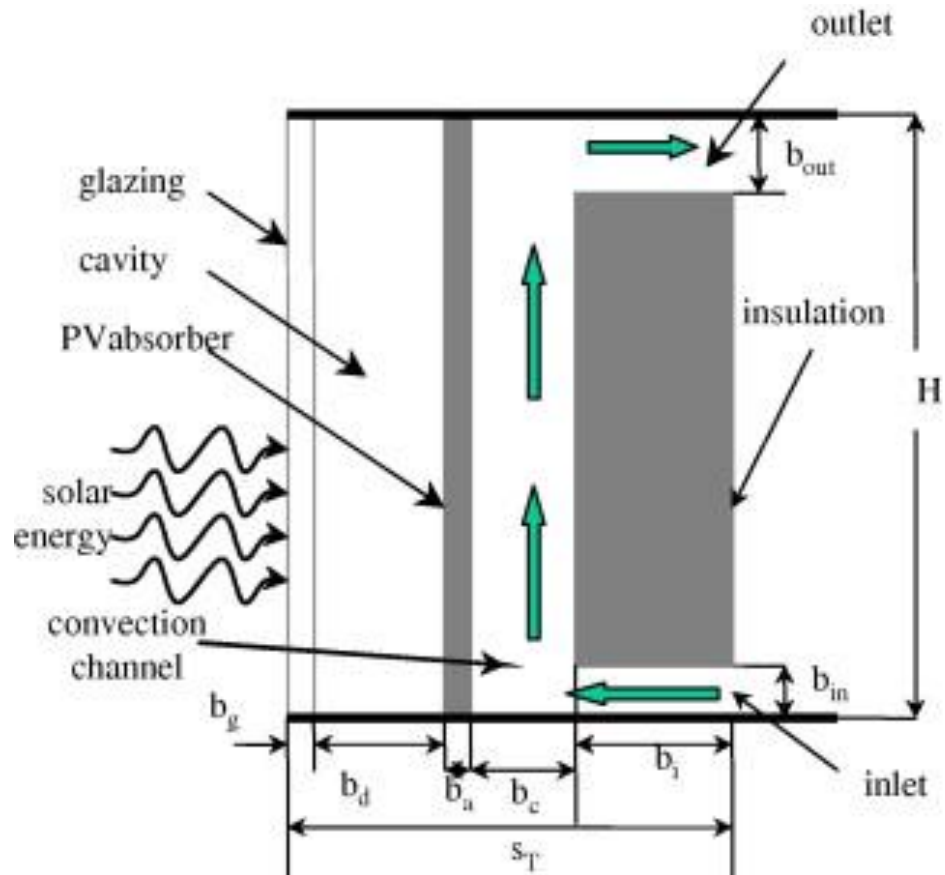



Photovoltaic façade paneling systems

Air barriers and sealants

The DuPont portfolio of innovative materials for photovoltaic modules

A Front Sheet Materials

DuPont® Teflon® films

B Photovoltaic Encapsulants

DuPont® PV1000 Series EVA resins
DuPont® PV5200 Series encapsulant sheets
DuPont® PV5300 Series encapsulant sheets

C Metallization Pastes

DuPont® Solamet® metallization pastes

D Thin Film Substrates

DuPont® Kapton® polyimide films
DuPont Teijin Films®

E Junction Box and Structural Support Materials

DuPont® Rynite® PET
thermoplastic polyester resins

F Back Sheet Materials

DuPont® Tedlar® PVF films
DuPont Teijin Films®

G High Performance Seals for Cell Manufacturing Equipment

Kabrez® perfluoroelastomer parts from
DuPont Performance Elastomers

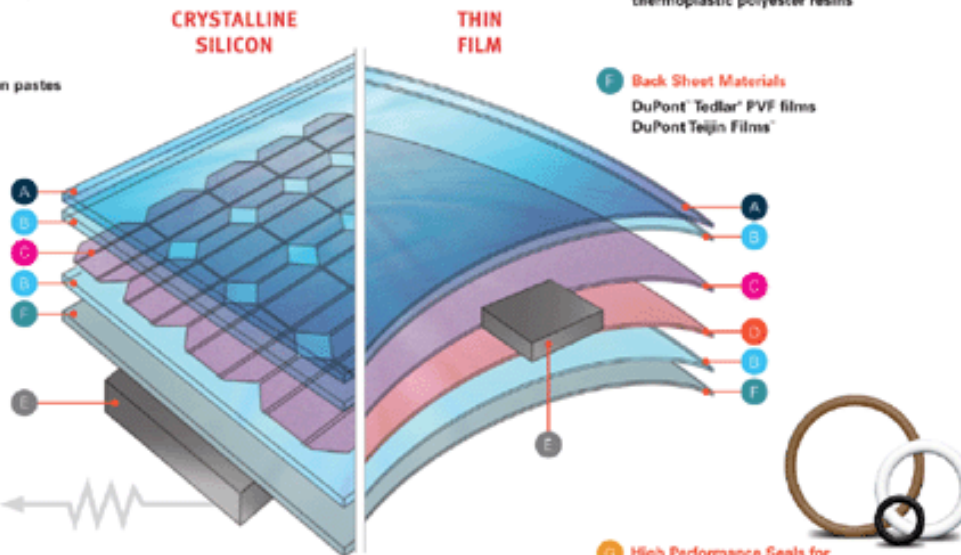

With a variety of alternative electrical generation systems available, none is becoming more prevalent than those which convert solar energy to electricity. These systems are known as photovoltaic systems, or simply PV. A photovoltaic system consists of photovoltaic solar panels and other electrical components used to capture solar energy and convert it to electrical power. Mostly these systems are roof mounted but they can serve as facades as well. PV systems are an economical and environmentally clean way to generate electricity and are here to stay.

Attachment systems and fire safety

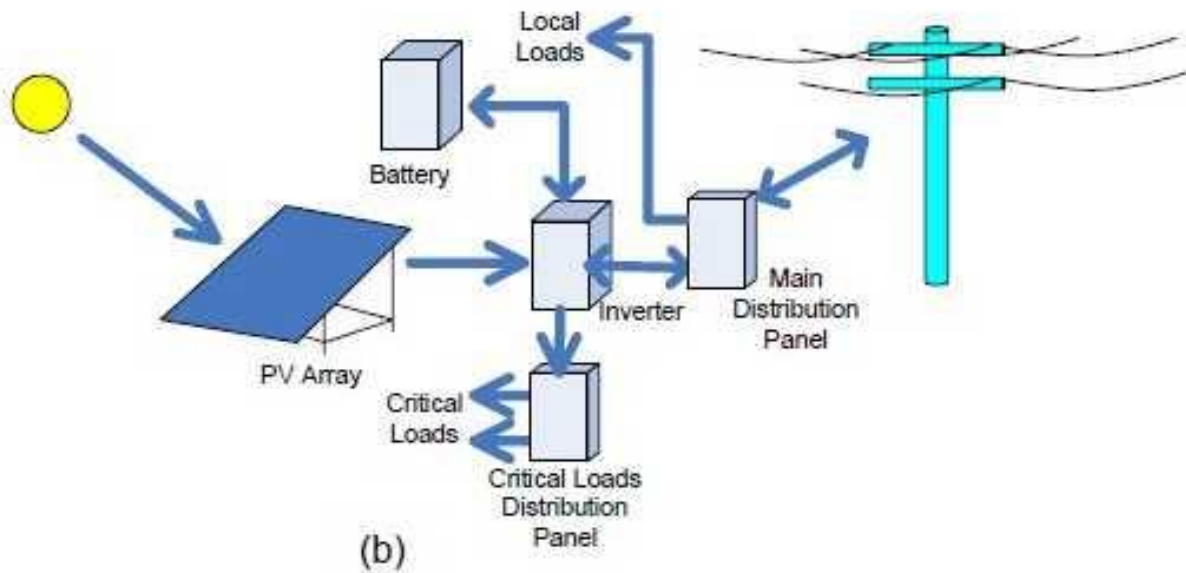

Photovoltaic systems are different, but not more dangerous, than traditional electrical installations. It is agreed that the best fire protection is the adherence to the existing regulations through qualified skilled workers.

The experts are to determine whether the existing, well-proven standards and safety concepts should be supplemented. The most important characteristic of photovoltaic systems is that they produce direct current. One cannot simply switch the power off, since the system continues to generate electricity as long as sunlight is incident on the modules.

Case study buildings



- Efficient and space-saving energy generation using the building shell
- Maximum energy yield due to optimum self-cleaning and rear ventilation
- Homogeneous flush-mounted, weather-resistant PV facade
- No visible mounting components
- Small module joints
- Integrated drainage system
- Minimal installation depth of just 80 mm

Case study buildings



Black PV module specifications

Properties	
Dimensions	991 x 1656 x 6.5 mm
Glass thickness	5 mm
Glass properties	Tempered solar safety glass

Mechanical specifications	
Backsheet	anthracite
Laminate structure	Glass / EVA / cells / EVA / backsheet
Weight	approx. 23.6 kg
Cell type	156 x 156 mm monocrystalline
Cell connection	60 cells, serial
Electrical junction box	Tyco Solarlok 4-Rail with 3 bypass diodes
Electrical connection cables	Tyco Solarlok 4 mm ² , length 1 m each
Electrical connectors	Tyco Solarlok Cable Coupler: Standard Line

Temperature coefficients	
α (I_{sc})	+0.04 %/K
β (U_{oc})	-0.33 %/K
γ (P_{mpp})	-0.43 %/K

Electrical specifications	
Nominal output	250 Wp
Voltage U_{mpp}	30.5 V
Current I_{mpp}	8.2 A
Open circuit voltage U_{oc}	37.8 V
Short circuit current I_{sc}	8.8 A
Maximum system voltage	1000 V
Cell technology	monocrystalline

Active building design with photovoltaics

Rain penetration and moisture control

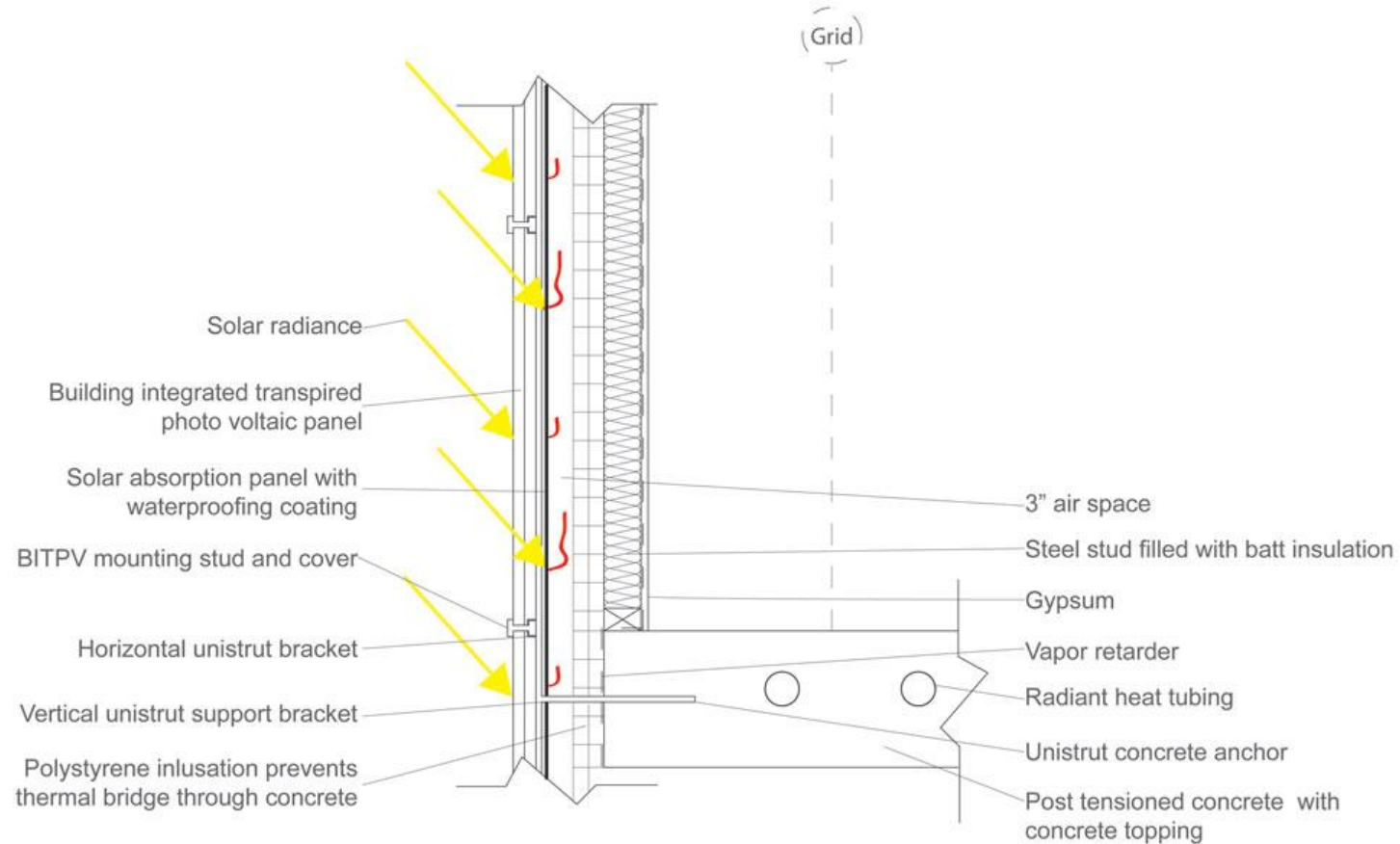

System joints and connections

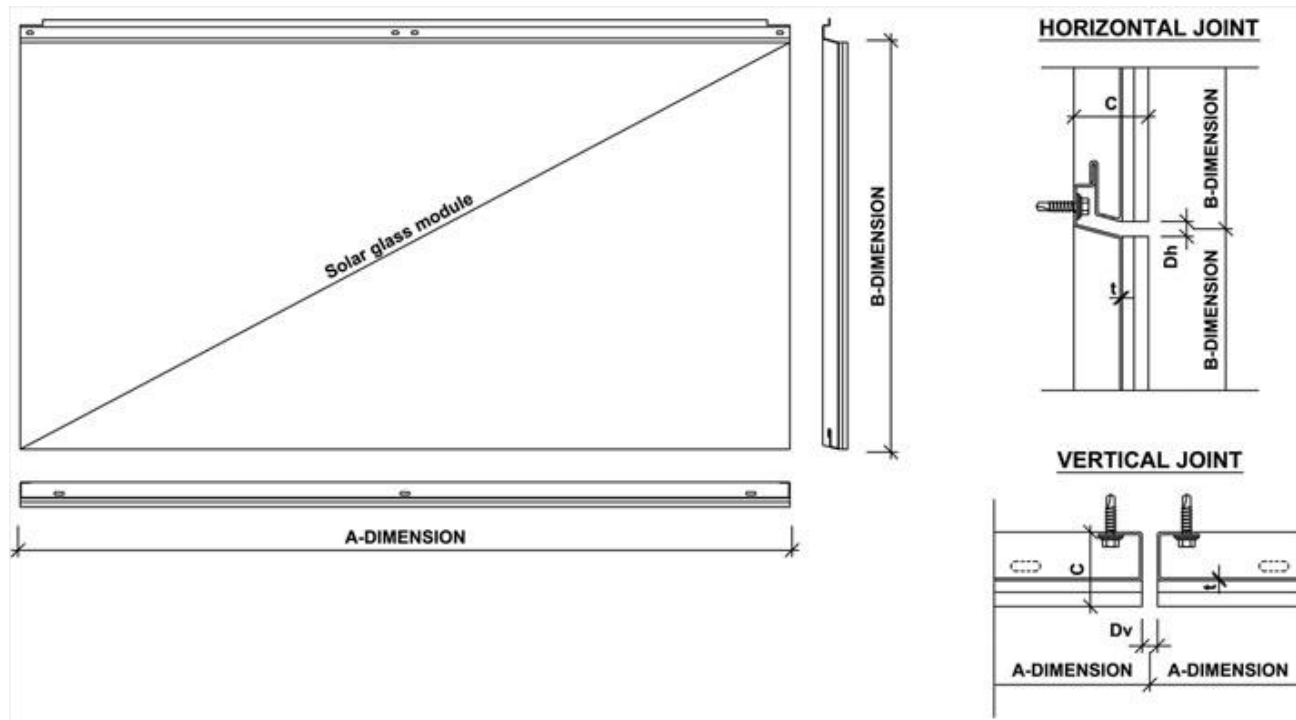

System joints and connections

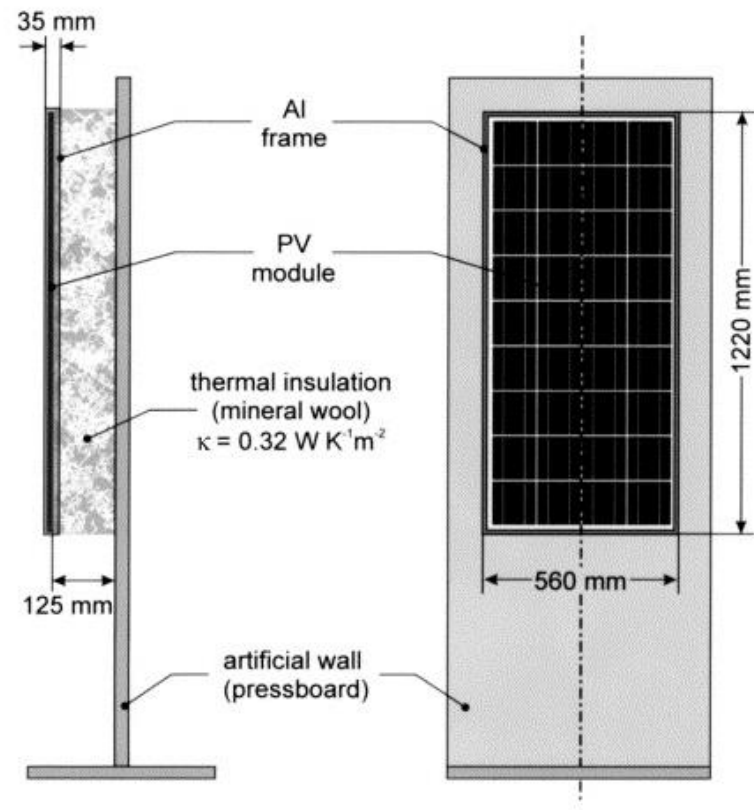
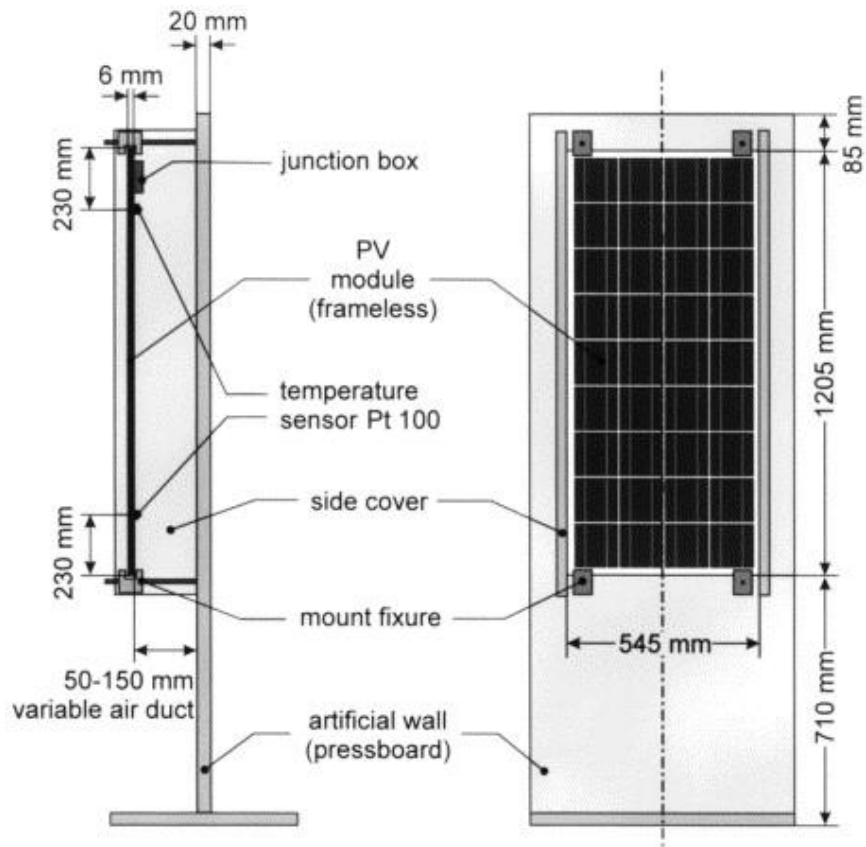

Systems comparison

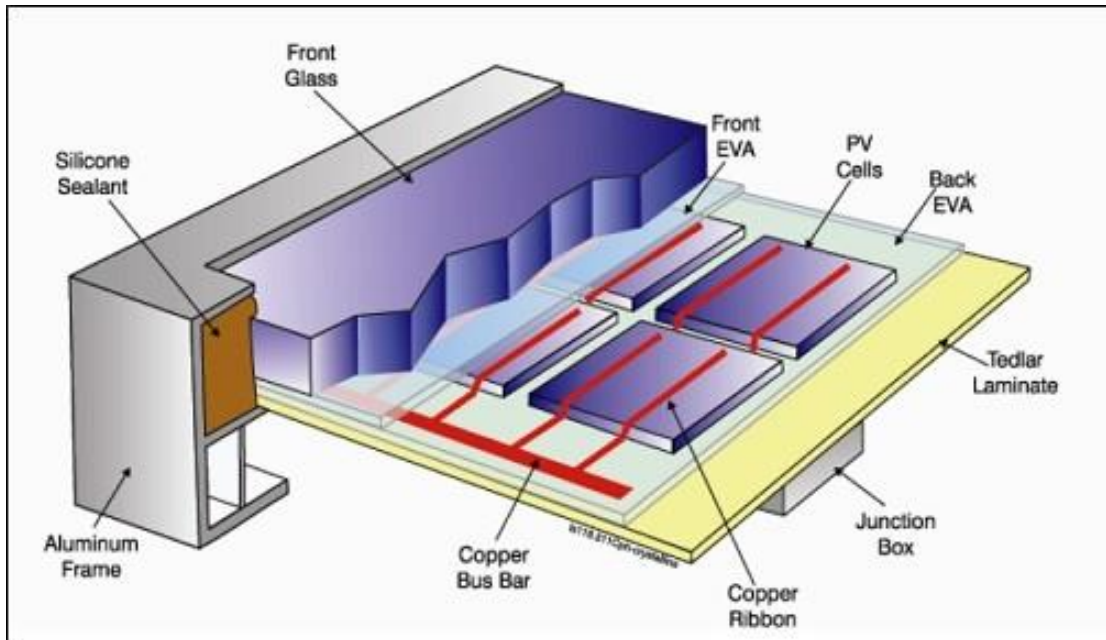

PowerVolt

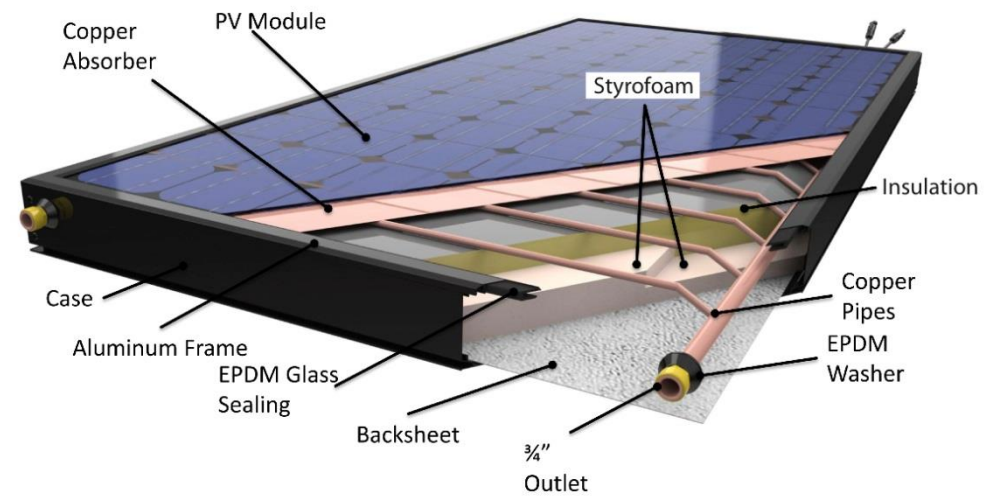

Systems comparison

post section with pv system

M 1:2

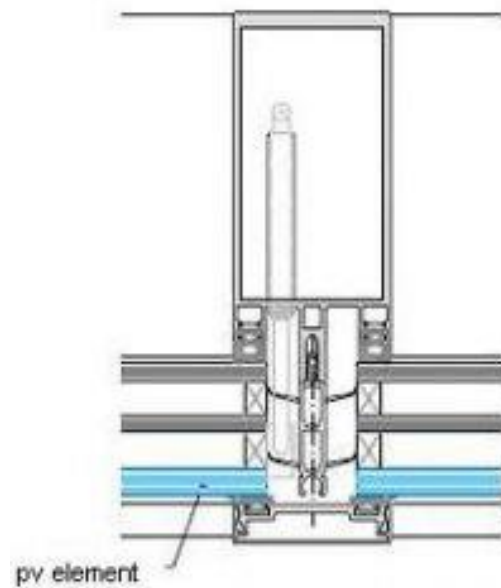

post section without pv system

M 1:2

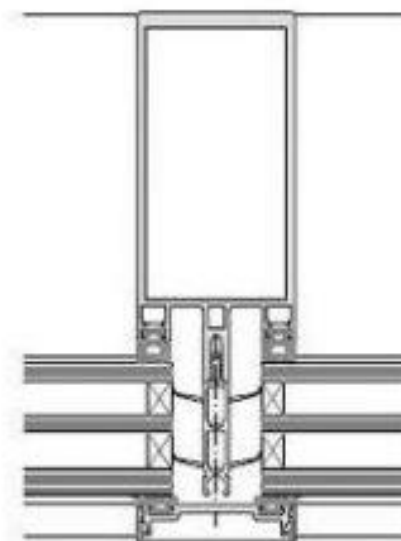

Thermal insulation and R value

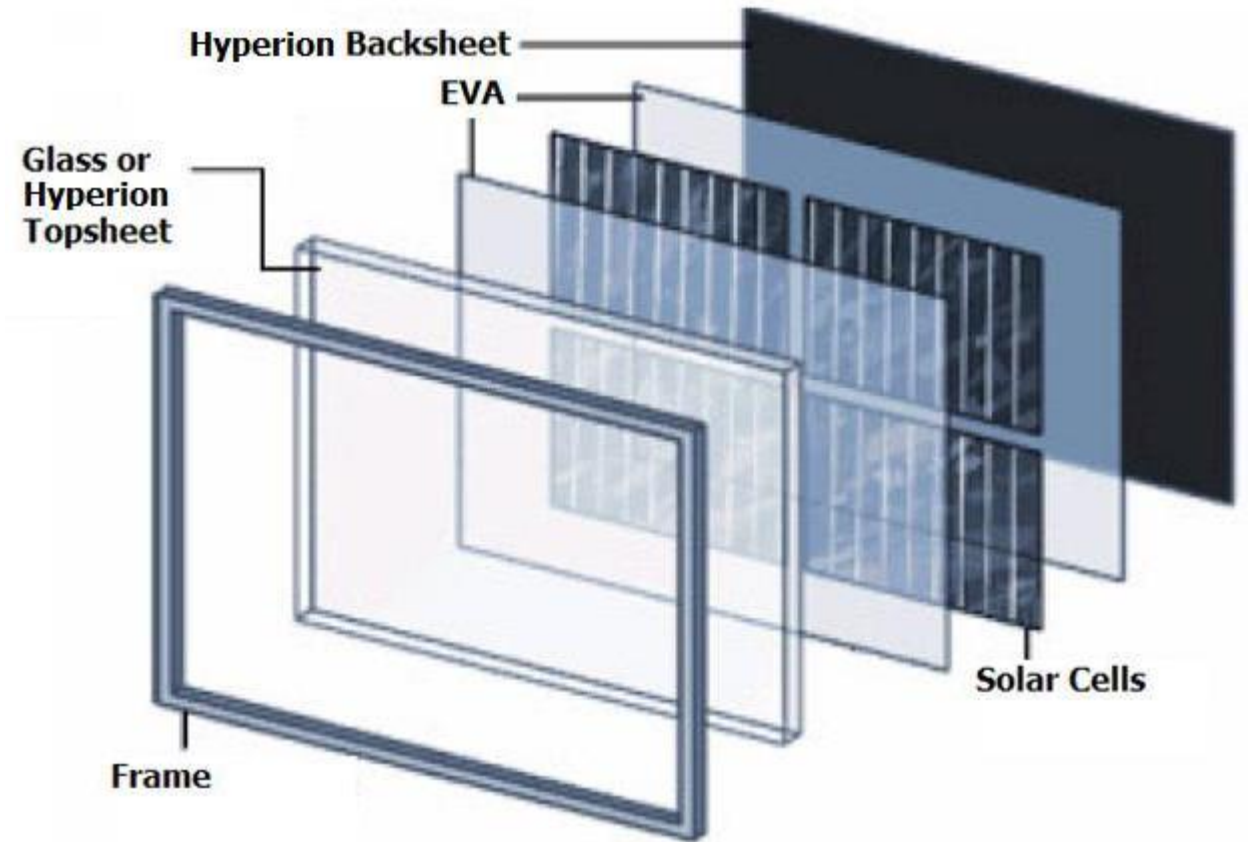
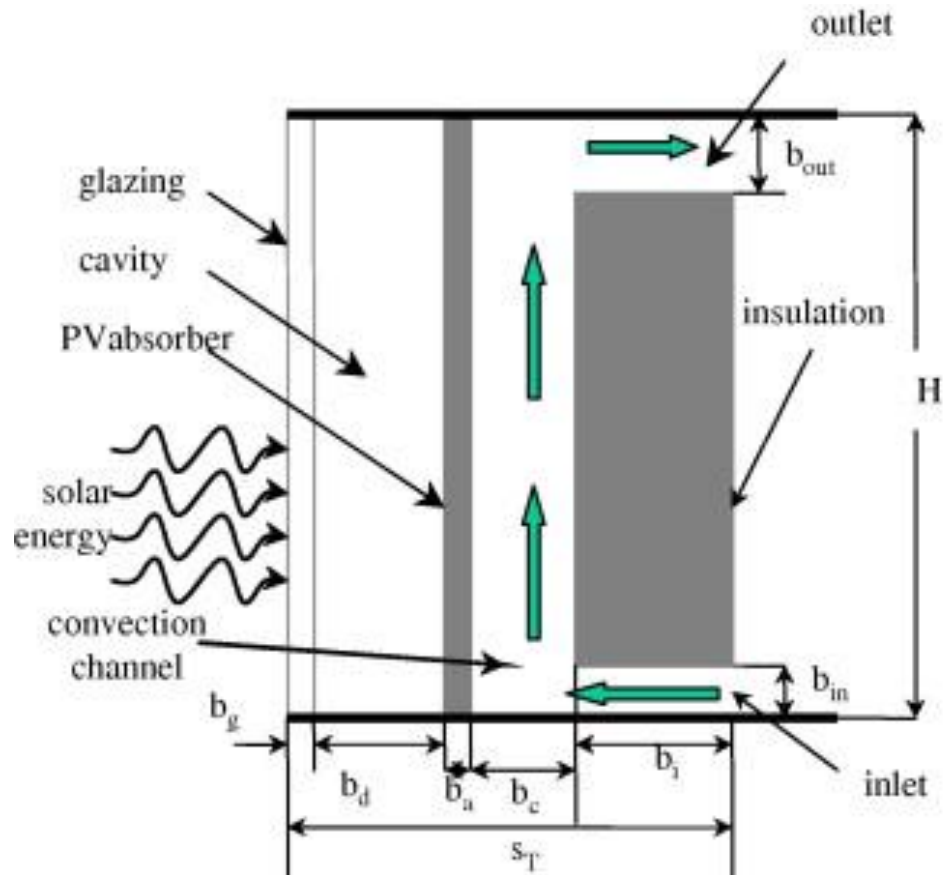



Thermal insulation and R value

η is the yield of the solar panel given by the ratio :
power (in kWp) of one solar panel divided by the area
of one panel

Example : the solar panel yield of a PV modules of 250
Wp with an area of 1.6 m² is 15.6%

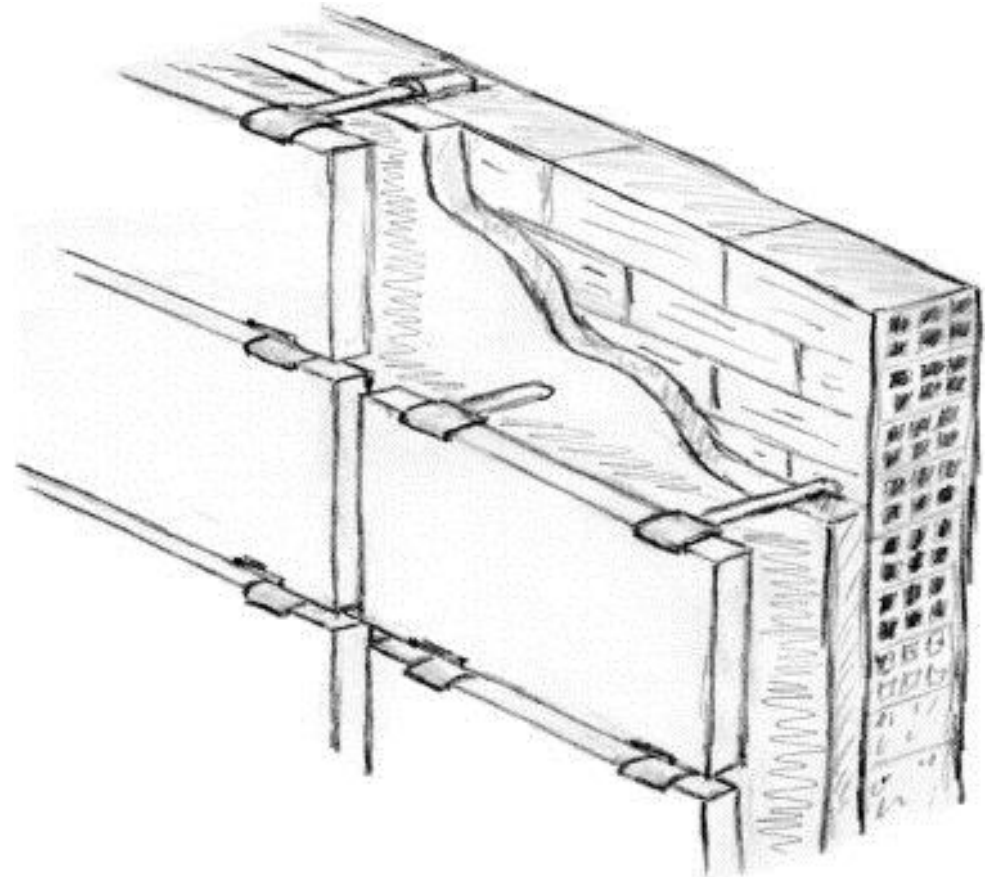
Be aware that this nominal ratio is given for standard
test conditions (STC) : radiation=1000 W/m², cell
temperature=25 °C, Wind speed=1 m/s, AM=1.5 The
unit of the nominal power of the photovoltaic panel in
these conditions is called "Watt-peak" (Wp or
kWp=1000 Wp or MWp=1000000 Wp).





Photovoltaic Façade Paneling Systems

Case Study Building

BUILDING: 20 River Terrace – The Solaire



LOCATION: The 20 River Terrace building is location in Battery Park City in New York City. It's known as the Multi-unit residential building. It is a 27 story building.

MATERIAL: The building is made of glass-and-brick.

Case study buildings



ENERGY: Green Strategies

- Day lighting for Energy Efficiency
- Use large exterior windows and high ceilings to increase day lighting

Photovoltaic

- Use building-integrated photovoltaic (PV) to generate electricity on-site

Function

Annual On-site Renewable Energy Production

Fuel	Quantity	MMBtu	kBtu/ft ²
Photovoltaics	34,300 kWh	117	0.328
Wind	0 kWh	0	0
Biomass electricity	0 kWh	0	0
Micro-hydro	0 kWh	0	0
Solar Thermal	0 kWh	0	0
Biomass thermal	0 kWh	0	0
Other	0 kWh	0	0

- About 3,400 square feet of photovoltaic panels generate about 5% of the base building.
- The photovoltaic cells are placed on the west portion of the building's façade. It takes advantage of the intensity and position of the sun in the summer months.

PHOTOVOLTAIC FACADE PANELING SYSTEM



- Photovoltaic is a system that convert sun ray or light into energy
- The sun is the only resource needed to power a solar photovoltaic system.
- Photovoltaic system can be used in renovating building, commercial, residential, office and industrial buildings.

Construction Time and Cost

- It is easy to install
- It can be delivered
- it is already or pre-design solar
- facade solution,
ready to be connected to the grid
- The price has reduced because of the high demand of the product/this system and the advance in technology in manufacturing scale.
- Easier to produce at low cost
- if u want a specific detail of a facade at a corner of a building you can have it

Environmental Implications and Sustainability



- It is economically sustainable and new way of renewable energy
- reduce cost and carbon emission in the building
- Most estimates of life-cycle emissions for photovoltaic systems are between 0.07 and 0.18 pounds
- The carbon footprint of photovoltaic is up to 65 times lower than that of fossil fuel-based electricity and is continuously decreasing
- Photovoltaic modules can be recycled and the materials can be reused.
- Photovoltaic is fuel free
- This system is beneficial to the environment and it also contributes to reducing the production cost

External Architectural Finishes and Durability



- Façade – PV can be incorporated into the sides of buildings, replacing traditional glass windows with crystalline solar panels.
- It function as a outer layer of structure and generate electricity on site
- lightweight, flexible and translucent, produced in different colors and patterned



External Architectural Finishes and Durability

Ten Key Advantages Of The Ventilated Photovoltaic Façade

- Electricity production
- Energy saving due to insulation properties (up to 40%)
- Greater insulation performance
- Elimination of thermal bridges
- Thermal inner comfort
- Reduction of acoustic pollution
- Wall and roof protection
- Greater energy yield under low irradiation conditions
- Greater energy yield under high temperature conditions
- Attractive and innovative design

Historical Systems Compared to Contemporary System

Historical System	Contemporary System
Only able to consume energy	Multifunctional
Can't produce energy when it is cloudy	Will give high performance under low light conditions such as fog
Can't rotate	orientation
It takes more time to produce energy that it collage from the sun	the amount of time it takes to generate enough energy to equal the energy used to produce it than traditional photovoltaic modules.
Traditional window cant convert sun ray into energy	Current development of photovoltaic system is trying to achieve to gain the maximum sunlight and panel to follow the sunlight as much it can
	Estimate : 20% in winter and 50% in summer

Internal options finishes and connections to partition walls



- Installation is quick and easy

System flexibility forms, sizes, effective spacing

- Cost it is available in standard size and also can choose shape, size, thickness, transparent and color effective
- The transparency is between 10%, 20% or 30%
- Can combine with any construction material

Step of ordering a standard photovoltaic glass

- Choose standard size that you need for your building
- Choose transparent degree- color, transparent, or semitransparent
- Choose any color
- Choose size of the glass (no standard size)
- Choose the thickness (no standard thickness)