

Earthquake®

Ground Breaking Ideas
2008



GetEarthquake.com



Earthquake, Division of Ardisam, Inc. • 800-345-6007



Innovative Outdoor Products Since 1960

Why Buy Earthquake?

In 1960, Earthquake hit the lawn and garden marketplace with the Ardis Quick Digger. Now, 48 years later, calls still come into our customer service center requesting parts for their Ardis Quick Digger. How can this be? In the age of throw away power equipment, Earthquake has stood strong on providing a high quality, long-lasting line of outdoor power equipment that stands the test of time.

Innovation.

Not only are Earthquake products built to last, but they also surpass the market with innovations that make the product better for the customer. The 1966 introduction of the revolutionary Isovibe shock absorbing technology, delivered more comfortable handling and further extended the life of the transmission. In 1983 the all ball bearing transmission was introduced to lessen maintenance issues associated with chain driven transmissions. Today Earthquake surpasses the market with the most versatile log splitter ever seen, the Trail Warrior Quick-Split 8. Years of research and development have also allowed Earthquake to execute the precise balance of speed, power, and performance in the technically advanced Viper Engine.

Value.

Earthquake does deliver the most dependable, innovative lawn and garden equipment, but more importantly you can afford to buy them. Typically, owning high performing, durable power equipment is only a wish of the average homeowner. Because of Earthquake's long standing history in the lawn and garden market, engineering durability has been perfected and it's our mission to deliver it at the best possible price.

Customer Service.

At Earthquake, we believe that when you purchase one of the many lawn and garden products we provide, that is not where our job ends. This is only the beginning. Your investment is important to us. Our customer service staff is highly qualified to help with anything you need. We have in-house technical experts with years of experience dealing with outdoor power equipment.

Earthquake is committed to providing the most innovative and dependable lawn and garden products at a price that is affordable. At the turn of every new season, Earthquake's research and development team will deliver the most innovative products to the lawn & garden marketplace. Stay tuned for the next ground breaking ideas.

Actual phone call to one of our customer service representatives

Barry Goffett called and wanted us to know his Model 5020 is the best tiller he has ever owned. He has had it 15 plus years and it still starts on the first pull.



On Your To-Do List, Do The Things You Love First.

Are you one who would choose an outdoor project over pretty much any other project?

Earthquake Lawn and Garden has engineered a line of products with you in mind. As an outdoor project enthusiast, you know the value a quality piece of equipment can provide to tasks which are labor intensive. The highly innovative mix of Earthquake Lawn and Garden products, provides you with the tools to make the job easier. What's more, the value of performance compared to price is unbeatable. So let Earthquake make those outdoor projects irresistible to almost any other activity you have on your list.

Earthquake, ground breaking ideas that won't break your bank.



Call 800-345-6007 or visit us at GetEarthquake.com to find a dealer near you and make that to-do list something you look forward to.



Proven Balance of Speed, Power and Performance.

Years of development, testing and analysis by a highly advanced group of engineers has produced an engine like no other. Viper's precise balance of speed, power and performance have been carried out in a high performance engine that will conquer the most difficult lawn or garden project. Whether it's the smaller 43 cc Viper or power rich 389 cc, the delivery of power is consistent and dependable. Viper continues to exceed your expectations.



Safer Drilling - Counteracts Sudden Twisting and Jolting

Earthquake's Isovibe anti-recoil earth auger safety feature is designed to protect the operator and the equipment from damage during drilling such as unforeseen hard spots in the soil (ie: rocks, roots, hardened dirt clods). More importantly, it makes the task much more comfortable.



Adjustable Depth of Tilling

Earthquake rototillers feature Isovibe adjustable drag stake technology. This allows you to control tilling at a depth that works for your garden and is maintained effortlessly throughout your garden. It also stabilizes the tiller by limiting unwanted up and down motions.



Patented Keyed Electric Start

Providing a key to convenience, the Earthquake MC43E Mini Cultivator delivers Keyed Electric Start. The durability and controlled handling of the MC43 combined with easy starting make the MC43E a must have for any gardening enthusiast.



Plug n' Split

The unexpected power of our electric W1000 log splitter provides an alternative to a large log splitter that can be difficult to maneuver without a vehicle. Simply plug it in and start splitting.

GetEarthquake.com

To continue Earthquake's effort to deliver a quality customer service experience, we are introducing a new and improved website. Manuals, parts ordering and detailed product information allow you to gather the information you need to make a well informed buying decision. What's even better is you can visit whenever you want 24 hours a day, 7 days a week.

Visit www.getearthquake.com today.



MINI CULTIVATOR ELECTRIC START

The patented MC43E continues to exceed your expectations with the high performance **Viper**® engine. It continues to provide the versatility of the MC43, but we've taken the ease-of-starting to the next level with a key-start engine. No need to pull start. Just turn the key and cultivate.

Actual customer comment

"My wife loves the electric start!"

David - Willow Spring, NC

FEATURES

- Keyed electric start
- No tool assembly
- Carrying bar makes loading and unloading a breeze
- Choose a tilling depth with adjustable wheel and drag stake
- Includes rechargeable battery and charger kit



Carrying Bar

MC43E

ENGINE
2-cycle 43cc
electric start



TRANSMISSION gear drive
GEAR RATIO 32:1
TILLING WIDTH 6"/10"
TILLING DEPTH 4"
TINE SPEED 250 rpm
WEIGHT 42 lbs
Rechargeable Battery



ACCESSORIES

Dethatcher Kit

Dethatch your lawn and promote healthy growth. Hardware included. (DK43)



Edger Kit

Clean up grass borders along sidewalks and driveways. Hardware included. (EK43)



MINI CULTIVATOR MANUAL START

Save time and effort with this compact and highly maneuverable mini cultivator. This revolutionary design delivers exceptional control and performance when loosening and mixing soil, blending fertilizer, and eliminating weed growth.

Actual customer comment

"[Earthquake Customer Service Representative] Eva displayed to me the best customer service. Total Value Recognition. Good job, Eva. Thanks."

Jim - Plymouth, IN

FEATURES

- Simple manual start
- Compact and lightweight
- High alloy brass gears



MC43

ENGINE
2-cycle 43cc



TRANSMISSION gear drive
GEAR RATIO 32:1
TILLING WIDTH 6"/10"
TILLING DEPTH 4"
TINE SPEED 250 rpm
WEIGHT 30.5 lbs



Actual customer email

"I just purchased [an MC43 Mini Cultivator in] Stillwater, OK. [I was impressed with the quality of this at such a great price.] This thing is awesome. I have used my inlaws [high priced cultivator from another manufacturer] and your Earthquake [cultivator] blows it away. Thanks for the great product and price!!"

Chip Palmer - Stillwater, OK

Where to buy. Visit GetEarthquake.com or call 800-345-6007 for a dealer near you.

49 state compliant. Not for sale in California.
Specifications are approximate and subject to change without notice.

GetEarthquake.com

ROTOTILLERS FRONT TINE

Earthquake's front tine rototiller series provides incredible maneuverability with the same power as a rear tine rototiller. Easily maneuvers around tight corners and narrow rows. Maximum stability due to the exclusive cast iron tail mount assembly makes it easier to control during tilling.

Front Tine Rototillers Maneuver Easily Around Tight Corners



3365	
ENGINE	
4-cycle, 5.50 ft-lbs Gross Torque, 158cc	
	
TILLING WIDTH	
3-way adjustable (11", 16", or 21")	
TILLING DEPTH 11"	
TINE SPEED 160 rpm	
WEIGHT 112 lbs	



FEATURES ▶

- Exclusive cast iron wheel mount assembly stabilizes the rototiller for better control
- Sturdy 1" solid steel tine shaft for long-life and rugged performance
- Front tine design offers preferred visibility – see your work area for better precision when tilling
- Tall 12" diameter transport wheels make it easy to maneuver in loose soil
- Handle bar folds down for easy storage and transport to multiple locations
- All-steel construction and high alloy brass gears deliver robust, durable, and reliable operation
- Belt engagement clutch allows user to stop the tines without stopping or even slowing the engine
- Adjustable tilling widths of 11", 16" or 21"



So smooth you can guide it with one hand.

It's the only front tine rototiller on the market that maintains easy, operational control and smooth, comfortable digging even in uncultivated soil.



Transition from Transport to Tilling Mode in One Easy Step

The revolutionary transitional wheel technology allows the user to switch between transport and tilling with a simple lift of the handle bar. This not only provides effortless transition, but also delivers exceptional safety.



With Earthquake's adjustable drag stake system, you control the depth of tilling. What's more the drag stake delivers better control of the machine by guiding you as you till.



Transport Mode



Simply lift and the wheels pivot to the necessary mode



Till Mode

SIMPLE TO OPERATE

✔ **Actual customer comment**
"Great Design!"
Scottie – Nicholasville, KY

INCREDIBLE MANEUVERABILITY

Where to buy. Visit GetEarthquake.com or call 800-345-6007 for a dealer near you.

49 state compliant. Not for sale in California. Specifications are approximate and subject to change without notice.

GetEarthquake.com



Glide through sod with amazing power and control!

ROTOTILLERS

REAR TINE - Counter and Standard Rotation

FEATURES ▶

- Isovibe adjustable drag-stake automatically maintains optimal digging level
- Isovibe technology eliminates porpoising and dragging effects
- Operates smoothly – with level digging performance in any soil
- Excellent for heavy soils and breaking sod
- Cast iron transmission provides ultimate durability and the added weight delivers better handling
- Ergonomically designed safety control lever

Shown with optional bumper guard

Counter Rotating Tines [CRT]

Designed for tough soil conditions, the CRT pulls forward against the counter rotating tines. This provides the power to tear up sod and heavy, uncultivated soil.

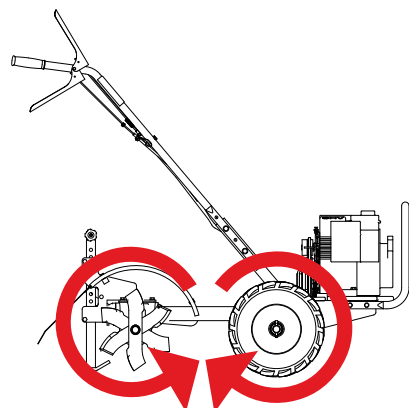

Shown with optional bumper guard

5055	
ENGINE Intek IC, 206cc 8.50 ft-lbs Gross Torque	
TILLING WIDTH	.16"
TILLING DEPTH	.10"
DIRECTION	Forward and Reverse
CONTROL	Forward and Reverse
HANDLEBAR	3-position
WHEEL NEUTRAL CONTROL	axle lock pins
TIRES	13 x 5.80-6
WEIGHT	180 lbs



6065VE	
ENGINE 4-cycle 196 cc	
TILLING WIDTH	.16"
TILLING DEPTH	.10"
DIRECTION	Forward and Reverse
CONTROL	Forward and Reverse
HANDLEBAR	3-position
WHEEL NEUTRAL CONTROL	axle lock pins
TIRES	13 x 5.80-6
WEIGHT	190 lbs

Multi-Position Depth Control

Adjustable Depth of Tilling

Earthquake's Isovibe adjustable drag stake technology allows you to till at a depth that works for your garden and what's even better is the depth you choose is maintained effortlessly throughout your garden.



Controlled Handling

Earthquake's Isovibe technology allows the user to have better control while tilling. Not only is the depth of tilling more easily maintained, but soil condition is improved as well.

Standard Rotating Tines [SRT]

Earthquake SRT models deliver dependable power. Great for seed beds and composting.

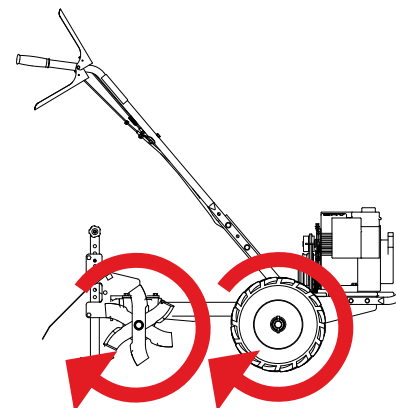

Shown with optional bumper guard

7065SV	
ENGINE 4-cycle 196cc	
TILLING WIDTH	.16"
TILLING DEPTH	.10"
DIRECTION	Forward and Reverse
CONTROL	Forward and Reverse
HANDLEBAR	3-position
WHEEL NEUTRAL CONTROL	axle lock pins
TIRES	13 x 5.80-6
WEIGHT	176 lbs



7055	
ENGINE Intek IC, 206cc 8.50 ft-lbs Gross Torque	
TILLING WIDTH	.16"
TILLING DEPTH	.10"
DIRECTION	Forward and Reverse
CONTROL	Forward and Reverse
HANDLEBAR	3-position
WHEEL NEUTRAL CONTROL	axle lock pins
TIRES	13 x 5.80-6
WEIGHT	176 lbs

ACCESSORIES ▶

Protect your tiller or improve your planting beds. See accessory page for more information.



▣ Bumper Guard

Extra protection bumper guard available with rugged design and easy installation. Hardware is included. (53599)



▣ Tiller Furrower

Great for improving your planting beds. Offers quick mounting with hardware included. (20002)

Where to buy. Visit GetEarthquake.com or call 800-345-6007 for a dealer near you.

49 state compliant. Not for sale in California.

Specifications are approximate and subject to change without notice.

GetEarthquake.com



Innovative Outdoor Products Since 1960

NEW!

EDGERS ELECTRIC START AND MANUAL START

The New WE43 Series Is Edging Out The Competition

The new Earthquake 43cc Edger provides an easy alternative to back breaking manual edgers. Manicure your sidewalks and driveways like a professional. The 43cc **Viper**® engine packs the power to clean up and maintain your toughest areas.

FEATURES ▶

- Electric Start unique to edgers
- Clutch driven throttle allows you to control speed at the handle
- 4-position height adjuster allows you to set the blade for the right depth and conditions
- Metal blade guard protects you from flying debris



Patent Pending



WE43E

ENGINE
2-cycle 43cc
electric start



WEIGHT 39 lbs
BLADE SIZE 9" diameter
CUTTING DEPTH adjustable - from 1/2" to 3"
WHEEL SIZE 7"
WARRANTY one year limited

WE43

ENGINE
2-cycle 43cc
manual start



See above for other specifications.



PRECISION CUTTING BLADE



NEW!

WATER PUMPS THREE MODELS

Lightweight Water Pump with the Power You Need

When you have to move water from one area to another, nothing beats the portability and power of an Earthquake water pump. Each model is designed to work quickly and efficiently.

FEATURES ▶

- General purpose pump
- Cast iron impeller (WP6520 & WP6530)
- Silicone carbide mechanical seal
- Lightweight aluminum pump housing
- One year residential warranty
- 90 day commercial warranty



WP430

ENGINE
2-cycle 43cc



TOTAL HEAD 82 ft
SUCTION LIFT 23 ft
MAX FLOW VOLUME 2300 GPH
INLET/OUTLET DIAMETER 1"
NET WEIGHT 13 lbs



WP6520

ENGINE
4-cycle 196cc



TOTAL HEAD 85 ft
SUCTION LIFT 26 ft
MAX FLOW VOLUME 9500 GPH
INLET/OUTLET DIAMETER 2"
NET WEIGHT 54 lbs

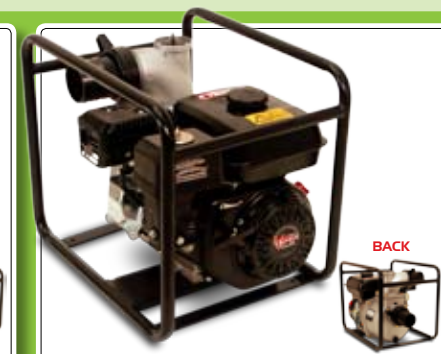

WP6530

ENGINE
4-cycle 196cc



TOTAL HEAD 82 ft
SUCTION LIFT 26 ft
MAX FLOW VOLUME 13,000 GPH
INLET/OUTLET DIAMETER 3"
NET WEIGHT 58 lbs



FAST, EFFICIENT WATER REMOVAL

Where to buy. Visit GetEarthquake.com or call 800-345-6007 for a dealer near you.

49 state compliant. Not for sale in California.

Specifications are approximate and subject to change without notice.

GetEarthquake.com

EARTH AUGER POWERHEADS

ONE PERSON

Smooth, Comfortable Handling

FEATURES ▶

- Outstanding power, durability and comfort
- Lightweight, yet heavy-duty construction
- Easy-to-grip fingertip throttle control
- Solid steel, heat-treated alloy gears
- See-through gas tank
- Quick start primer
- Steel muffler guard
- Anti-vibration foam grip handle



Revolutionary **Iso-vibe Technology** delivers maximum power without the unmanageable twisting and jerking of other augers (6", 8", & 10" models)



DRILL DEEP INTO THE EARTH IN SECONDS

We're the largest manufacturer of earth augers in the world!

EARTH AUGER POWERHEADS

TWO PERSON

For The Big Jobs.

Earthquake's two-person earth augers are designed for the big jobs. This super-duty unit is able to tackle a wide range of soils and rips a hole as large as 14 inches in diameter with exceptional control.

FEATURES ▶

- Solid steel, heat-treated alloy gears
- 3" heavy duty centrifugal clutch
- Easy-to-grip fingertip throttle control
- Sturdy 12 gauge steel handlebar



Stability in Unstable Soils

Earthquake's Iso-vibe Flex Coil technology lends itself to stabilizing power earth auger drilling. In soil that is rocky, Isovibe prevents the user from being jerked around by rocks or hard spots in the soil.



E43

ENGINE
2-cycle 43 cc



GEAR RATIO 30:1
MAXIMUM RPM 250
WEIGHT
(POWERHEAD ONLY) . . . 19 lbs
AUGER DIAMETERS
(INCHES) 2, 3, 4, 6, 8, 10

✔ **Actual customer comment**
"Great product... made my job easy, excellent value for the price!"
John - Grantsville, UT



9000E

ENGINE
85 cc, 2-cycle Tecumseh

GEAR RATIO 16:1
MAXIMUM RPM 280
WEIGHT
(POWERHEAD ONLY) . . . 26 lbs
AUGER DIAMETERS
(INCHES) 2, 3, 4, 6, 8, 10



EARTH AUGERS WITH FISH TAIL

MODEL NAME	ITEM NUMBER
4" auger	EA4F
3" auger	EA3F
2" auger	EA2F



EARTH AUGERS WITH FISH TAIL AND SHOCK SPRING

MODEL NAME	ITEM NUMBER
10" auger	EA10F
8" auger	EA8F
6" auger	EA6F



9800H

ENGINE
Honda GCV160
5.5 hp



GEAR RATIO 30:1
MAXIMUM RPM 121
WEIGHT
(POWERHEAD ONLY) . . . 54 lbs
AUGER DIAMETERS
(INCHES) 2, 3, 4, 6, 8, 10, 12, 14



9800B

ENGINE
6.75 ft-lbs Gross Torque
190cc



GEAR RATIO 30:1
MAXIMUM RPM 121
WEIGHT
(POWERHEAD ONLY) . . . 52 lbs
AUGER DIAMETERS
(INCHES) 2, 3, 4, 6, 8, 10, 12, 14

✔ **Actual customer comment**
"Best auger I have ever used!"
Sammy - Hartsville, SC

ACCESSORIES ▶

Choose the right auger, extend your current auger, or replace your blades.
See accessory page for more information.

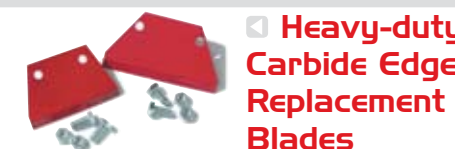

Where to buy. Visit GetEarthquake.com or call 800-345-6007 for a dealer near you.

GetEarthquake.com

Specifications are approximate and subject to change without notice.

NEW!

LOG SPLITTERS GAS POWERED OR ELECTRIC

Earthquake HIGH PERFORMANCE TRAIL WARRIOR QUICK-SPLIT 12

- DUAL SPLITTING HEIGHT
- TANDEM HAULING
- TELESCOPING TONGUE
- LOW CENTER OF GRAVITY

Patent Pending

2-Position Beam
Split at two different heights with the innovative lifting beam.



Stability During Transport
The large flotation tires, low profile, and wide stance make this log splitter extremely stable during transport. Designed for off-road hauling only.

Tandem Hitch
Now you can tow your log splitter and your trailer at the same time. Designed for off-road hauling only.

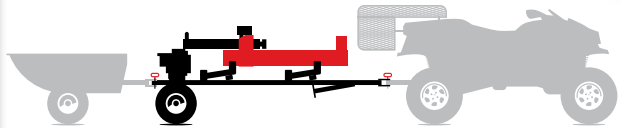

Telescoping Tongue
The tongue extends to stay clear of the extended rack on your ATV.



W1265V
ENGINE 4-cycle 196cc
MAX SPLITTING FORCE . . . 12 tons
MAXIMUM LOG LENGTH . . . 21"
HYDRAULIC OIL CAPACITY . . . 6 quarts
WEDGE . . . 7" high
HITCH . . . Pin Style
TANDEM HITCH . . . Pin or Ball Style
(Ball hitch not included)
Also available with a Briggs & Stratton engine



Patent Pending



More Efficient Splitting Wedge
Unique splitting wedge is designed to split logs faster.

14-16 Seconds
Efficient Splitting Speed
With a 14-16 second splitting cycle, you are sure to get the job done in a hurry. Manual log splitting is extremely hard work and takes a long time. Earthquake's line of log splitters allow you to split up to 4 logs per minute or over 200 logs in an hour.



Beam Lock-Down
This chain secures beam during transport.



Drop Down Stand
When storing the splitter in a tight spot, fold up the tongue and drop down the black stand for support.



Versatile
For heavy logs, the vertical orientation allows you to split logs without having to lift them up onto the cradle.



W2813V Also available with a Briggs & Stratton engine
ENGINE 4-cycle 389cc
MAX SPLITTING FORCE . . . 27 tons
CYLINDER . . . 4.5" diameter, 24" stroke
PUMP . . . 2-stage 16 gpm
MAXIMUM LOG LENGTH . . . 24"
CYCLE TIME . . . 16 seconds
HYDRAULIC OIL CAPACITY . 3.75 gallon
WEDGE . . . 7" high
BEAM SIZE6" x 6"
BALL HITCH 2"



W2265V
ENGINE 4-cycle 196cc
MAX SPLITTING FORCE . . . 22 tons
CYLINDER4" diameter, 24" stroke
PUMP . . . 2-stage 11 gpm
MAXIMUM LOG LENGTH . . . 24"
CYCLE TIME . . . 14 seconds
HYDRAULIC OIL CAPACITY . 3.75 gallon
WEDGE . . . 7" high
BEAM SIZE6" x 6"
BALL HITCH 2"



W1000
ENGINE Electric 1.75 hp, 120 v/60hz, 15 amp
MAX SPLITTING FORCE . . . 4 tons
LOG CAPACITY . . 20" long x 10" diameter
CYCLE TIME . . . 16 seconds
HYDRAULIC PRESSURE . . 2,300 psi
WEDGE . . . 5" high
DIMENSIONS37" x 11" x 20"
WEIGHT 93 lbs

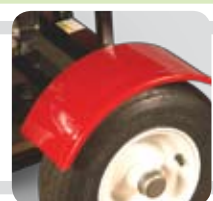

Fenders
Prevent debris from flying up while towing by adding fenders. (WF2228)

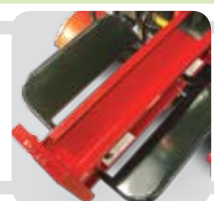

Log Cradle
Earthquake's log cradle catches split logs as they fall to the side of the beam (for W2813V and W2265V only). (1692210)

Where to buy. Visit GetEarthquake.com or call 800-345-6007 for a dealer near you.

49 state compliant. Not for sale in California. Specifications are approximate and subject to change without notice.

CHIPPERS/SHREDDERS

TWO POWERFUL ENGINES TO FIT YOUR NEEDS



Triangulated Force Triples the Power and Triples the Impact!

With our patented triple triangular hammer, Earthquake Chipper/Shredders offer maximum power at the point of impact. Triangulating the force actually increases shredding and chipping power, so Earthquake Chipper/Shredders chip materials quickly and easily.

FEATURES ▶

- Chip materials up to 3" diameter
- Two 2" chipping knives – heavy-duty yet remarkably razor sharp
- Two Tri and two J shredder hammers – J-hammers cut material reducing it's size and Tri-hammers pulverize
- 20:1 waste reduction ratio
- Includes one 2-bushel bag

WASTE MAKES EXCELLENT MULCH



34"
Hopper is placed at a height that provides comfortable handling.



Durable and Compact

Large wheels roll effortlessly over lawn and garden, while the compact design takes less storage space. Designed with a durable flywheel and chipping block and bright red and black finish, Earthquake's Chipper/Shredders stand up to heavy use, year after year.

20:1
Waste Reduction Ratio

Vacuum Kit



9010400
ENGINE
CE, 305cc
14.50 ft-lbs Gross Torque
HAMMERS
(2) Tri-Hammers, (2) J-Shredder Hammers
ROTOR Steel
GRINDING CHAMBER . 2.5" x 14"
HOPPER 16.75" x 13.25"
WEIGHT 133 lbs.



9060300
ENGINE
Intek IC, 206cc
8.50 ft-lbs Gross Torque
HAMMERS
(2) Tri-Hammers, (2) J-Shredder Hammers
ROTOR Steel
GRINDING CHAMBER . 2.5" x 14"
HOPPER 16.75" x 13.25"
WEIGHT 97 lbs.



Amazing Triple Cutting Action Devours Brush

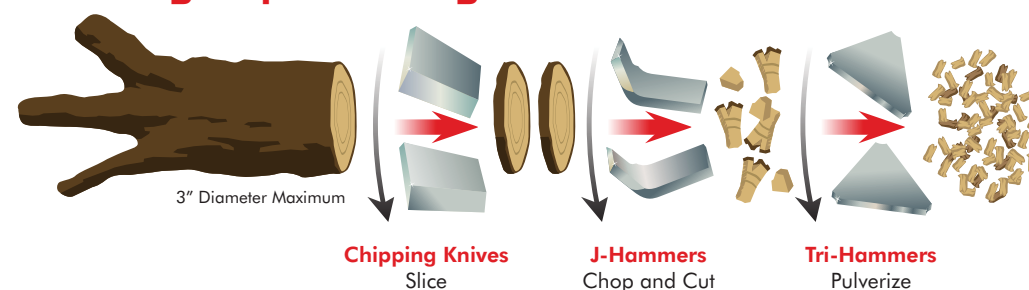

Self-feeding Action

Dual knives are placed at angles to create a self-feeding mechanism. As the knives rotate and cut, they pull the material into the three-phase cutting chamber. Plus, the hopper stands 34" high offering a comfortable working height while still maintaining a low center of gravity for increased stability.

ACCESSORIES ▶

Add versatility to your Earthquake Chipper/Shredder. See accessory page for more information.



◀ Tow Bar

Pull your chipper/shredder easily with a garden tractor using an Earthquake Tow Bar. (1692327)

▶ Vacuum Kit

Earthquake's Vacuum Kit simplifies leaf removal. Adjustable velocity control allows operator to set velocity to vacuum leaves under shrubbery without disturbing decorative chips or rocks. (1692210)



Where to buy. Visit GetEarthquake.com or call 800-345-6007 for a dealer near you.

49 state compliant. Not for sale in California. Specifications are approximate and subject to change without notice.

GetEarthquake.com

HIGH POWERED GAS DRILL



WOOD CHUCK HIGH POWERED GAS DRILL

Whether you're building a new home or just repairing some wood fencing, our Wood Chuck high powered gas drill is made for the job. Because it has no power cord, and doesn't require rechargeable batteries, its gas-driven high performance **Viper®** engine can go anywhere, anytime.

- FEATURES**
- Solid steel, heat treated alloy gears
 - Standard 1/2" chuck and key included
 - Muffler guard for added safety
 - Industrial size cordless drill needs no electricity

E43WC

ENGINE
2-cycle 43cc

VIPER
ENGINES

GEAR RATIO 13:1
 MAXIMUM RPM 600
 WEIGHT
 (POWERHEAD ONLY) 20 lbs
 BIT SHANK SIZE 1/2 inch



Works great for tapping maple trees, building log homes or working on wood fences.



Revolutionary **Iso-vibe Technology** delivers maximum power without the unmanageable twisting and jerking of other augers (6", 8", & 10" models)

EXTENSIONS

REPLACEMENT BLADES

HEAVY DUTY TUNGSTEN CARBIDE REPLACEMENT BLADES

TREE POTTING AUGERS

EARTH AUGERS WITH FISH TAIL AND SHOCK SPRING

EARTH AUGERS WITH FISH TAIL

Visit your local authorized **Earthquake** dealer or call **800-345-6007** for a dealer near you.

EXTENSIONS	
MODEL NAME	ITEM NUMBER
18" extension 7/8" shaft	EXT18
12" extension 7/8" shaft	EXT12
6" extension 7/8" shaft	EXT6

REPLACEMENT BLADES	
MODEL NAME	ITEM NUMBER
12" replacement earth blade	EB12
10" replacement earth blade	EB10
8" replacement earth blade	EB8
6" replacement earth blade	EB6
4" replacement earth blade	EB4

HEAVY DUTY TUNGSTEN CARBIDE REPLACEMENT BLADES	
MODEL NAME	ITEM NUMBER
10" HD replacement blade	EB10HD
8" HD replacement blade	EB8HD
6" HD replacement blade	EB6HD

TREE POTTING AUGERS	
MODEL NAME	ITEM NUMBER
14" tree potting auger	EA14F
12" tree potting auger	EA12F

EARTH AUGERS WITH FISH TAIL AND SHOCK SPRING	
MODEL NAME	ITEM NUMBER
10" auger	EA10F
8" auger	EA8F
6" auger	EA6F

EARTH AUGERS WITH FISH TAIL	
MODEL NAME	ITEM NUMBER
4" auger	EA4F
3" auger	EA3F
2" auger	EA2F

Where to buy. Visit GetEarthquake.com or call **800-345-6007** for a dealer near you.

49 state compliant. Not for sale in California.
 Specifications are approximate and subject to change without notice.

GetEarthquake.com



LOADING RAMPS

Folding and Arch Ramps

Effortless Loading

Our selection of ramps makes loading your lawn and garden equipment or ATV effortless. The new Extreme Duty Arch Ramp provides a whole new level of loading strength. Reinforcing center struts give 2200 lbs of capacity for heavier equipment.

FEATURES

- Heavy-duty hinges
- Rubber coated tabs prevent tailgate scratches
- Adjustable straps keep the ramps in place
- The folding models deliver compact portability

Aluminum Folding XL Arch Ramps
Perfect for vehicles with low clearance. Lightweight, compact folding design is ideal for short bed pickup trucks.



Aluminum
NEW!

REINFORCING CENTER STRUTS

Extreme Duty Arch Ramp (AVI38)

DIMENSIONS	
	. 12" x 83" single
CONSTRUCTION	
	Welded Aluminum
CAPACITY	
	1100 lbs single ramp
	2200 lbs pair
WEIGHT	
	. 38 lbs as a pair



Aluminum

FOLDS FOR PORTABILITY

XL Folding Arch Ramp (AVI07)

DIMENSIONS	
	. 12" x 89" single ramp open
	. 12" x 44.5" single ramp folded
CONSTRUCTION	
	Welded Aluminum
CAPACITY	
	625 lbs single ramp
	1250 lbs pair
WEIGHT	
	. 38 lbs as a pair



Aluminum

TREAD GRIPPING MESH SURFACE

XL Arch Ramp (AVI05)

DIMENSIONS	
	. 12" x 89" open
CONSTRUCTION	
	Welded Aluminum
CAPACITY	
	625 lbs single ramp
	1250 lbs pair
WEIGHT	
	. 34 lbs as a pair

THESE RAMPS ARE SPECIALLY DESIGNED FOR LAWN & GARDEN WITH TREAD GRIPPING MESH.



Yukon Tracks offers a large variety of ramps...

In addition to ramps designed for Lawn & Garden, a large selection of ramps designed for ATVs help you to load and unload your ATV with complete confidence. Whether aluminum or steel, each model's durability is superb. To view the wide selection of available ramps, go to GetYukonTracks.com.

Where to buy. Visit GetYukonTracks.com or call 800-345-6007 for a dealer near you.

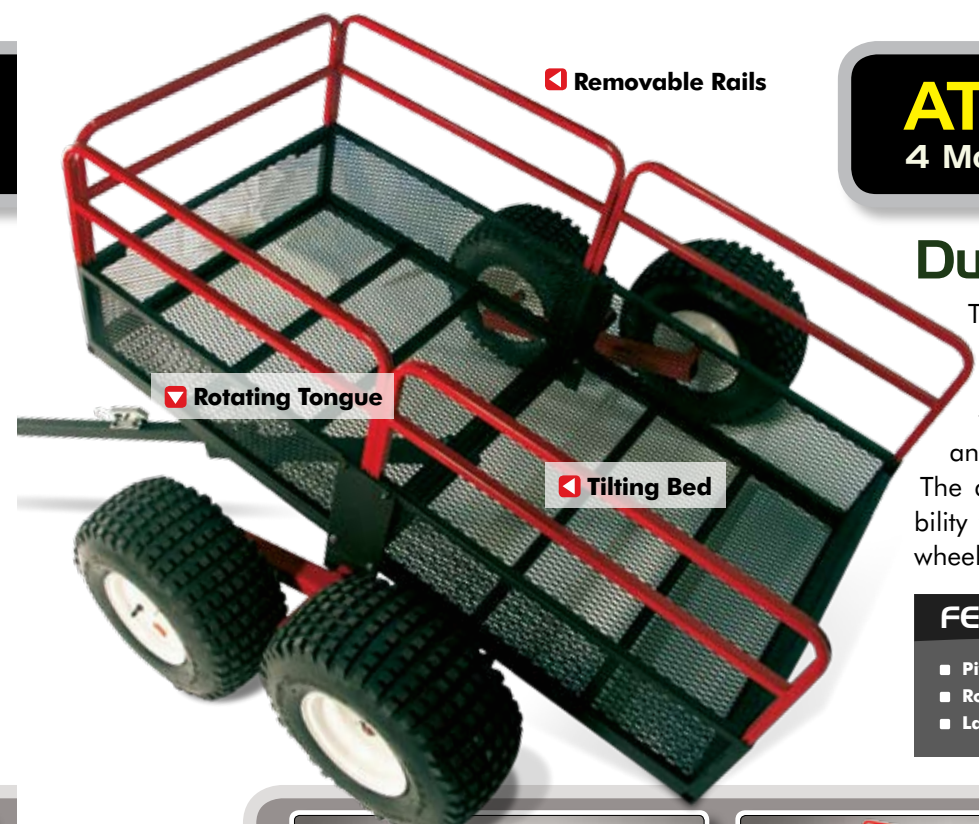

ATV TRAILERS

4 Models To Choose From

Dual use pivot / tilt design

These rugged ATV trailers are sure to satisfy all your hauling needs. Each one features a heavy-duty steel frame, heavy-duty wheel bearings and extra large flotation tires to handle rough terrain. The Caribou™ and Moose™ feature high-density polyethylene tubs. The all-new Trail Warrior series delivers maximum durability with all-steel construction. Choose between 2 or 4 wheels based on the application.

FEATURES

- Pivoting and tilting tub/bed
- Robust construction
- Large flotation tires walk over large bumps



NEW!

Trail Warrior X4 (AVI59)

BED SIZE	. 60" L x 31" W x 9" D
with Rails	. 60" L x 31" W x 21" D
TIRE SIZE	. 18" x 8.5" - 8 Flotation
CAPACITY	. 1250 lbs
BED VOLUME with Rails	20.5 cu ft



NEW!

Trail Warrior X2 (AVI58)

BED SIZE	. 60" L x 31" W x 9" D
with Rails	. 60" L x 31" W x 21" D
TIRE SIZE	. 18" x 8.5" - 8 Flotation
CAPACITY	. 1250 lbs
BED VOLUME with Rails	20.5 cu ft



Moose™ (AVI18)

TUB SIZE	. 78" L x 38.5" W x 14" D
TIRE SIZE	. 18" x 8.5" - 8 Flotation
CAPACITY	. 1250 lbs
TUB VOLUME	. 24 cu ft

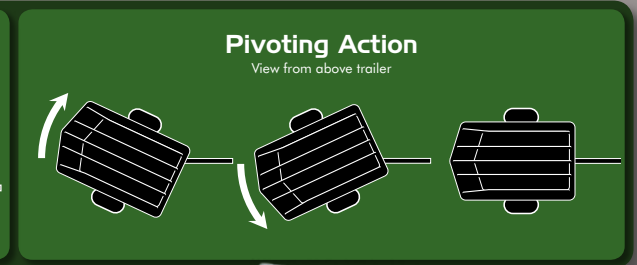

Caribou™ (AVI17)

TUB SIZE	. 62" L x 31" W x 14" D
TIRE SIZE	. 18" x 8.5" - 8 Flotation
CAPACITY	. 1250 lbs
TUB VOLUME	. 15.5 cu ft

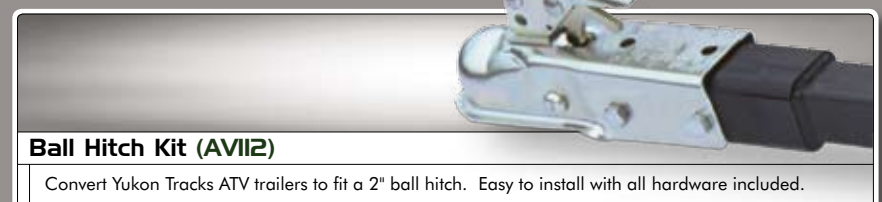

Ball Hitch Kit (AVI12)
Convert Yukon Tracks ATV trailers to fit a 2" ball hitch. Easy to install with all hardware included.

REAR TINE ROTOTILLER



Bumper Guard

Protect your rototiller engine and front end with one of our quality bumper guards. Rugged design and easy to mount. Hardware is included.



Hiller Furrower

Great for improving your planting beds. Offers quick mounting with hardware included.

MINI CULTIVATOR



Edger Kit

The Earthquake mini cultivator accepts an optional edger kit for cleaning up grass borders along sidewalks, driveways, and flower beds.



Dethatcher Kit

Attach the dethatcher kit to dethatch your lawn and promote healthy growth.

CHIPPER/SHREDDER



Vacuum Kit

Adjustable velocity control allows operator to set velocity to vacuum leaves under shrubbery without disturbing decorative chips or rocks.



Tow Bar

Pull your Chipper/Shredder easily with a garden tractor using an Earthquake Tow Bar.

LOG SPLITTER



Wheel Fenders

Prevent debris from flying up while towing by adding fenders.



Log Cradle

Earthquake's log cradle provides better control of log placement on the splitting platform. Hardware included.

REAR TINE ROTOTILLER ACCESSORIES

MODEL NAME	ITEM NUMBER
Bumper Guard	53599
Hiller/Furrower	20002

CHIPPER/SHREDDER ACCESSORIES

MODEL NAME	ITEM NUMBER
Vacuum Kit	1692210
Tow Bar	1692327

LOG SPLITTER ACCESSORIES

MODEL NAME	ITEM NUMBER
Wheel Fenders	WF2228
Log Cradles	LC2228

MINI CULTIVATOR ACCESSORIES

MODEL NAME	ITEM NUMBER
Edger Kit	EK43
Dethatcher Kit	DK43

Actual customer comment for E43 Earth Auger

"This tool save me a lot of time and effort when I built our hay barn. A good tool!"

Gary - Anna, TX

ROTOTILLERS / CULTIVATORS

FRONT TINE	ENGINE	POWER	TILLING WIDTH	TILLING DEPTH	TINE SPEED	GEAR RATIO	WEIGHT
3365	Briggs & Stratton	5.50 ft-lbs Gross Torque	3-way adjustable (11", 16" or 21")	11"	160 rpm	NA	112 lbs
MC43E	Viper	43cc	10"	4"	250 rpm	32:1	42 lbs
MC43	Viper	43cc	10"	4"	250 rpm	32:1	30.5 lbs

REAR TINE	ENGINE	POWER/ SIZE	TILLING WIDTH	TILLING DEPTH	DIRECTION CONTROL	CRT/SRT	WEIGHT
5055	Briggs & Stratton	8.50 ft-lbs Gross Torque	16"	10"	forward and reverse	CRT	180 lbs
6065VE	Viper	196cc	16"	10"	forward and reverse	CRT	190 lbs
7065V	Viper	196cc	16"	10"	forward and reverse	SRT	176 lbs
7055	Briggs & Stratton	8.50 ft-lbs Gross Torque	16"	10"	forward and reverse	SRT	176 lbs

EDGER

MODEL	START	ENGINE	TYPE	WEIGHT	BLADE SIZE	CUTTING DEPTH	WHEEL SIZE
WE43E	Electric	Viper	43cc	39 lbs	9" Diameter	Adjustable (.5" - 3")	7"
WE43	Manual	Viper	43cc	39 lbs	9" Diameter	Adjustable (.5" - 3")	7"

WATER PUMPS

MODEL	ENGINE	SIZE	TOTAL HEAD	SUCTION LIFT	MAX FLOW VOLUME	INLET/OUTLET DIAMETER	NET WEIGHT
WP4310	Viper	43cc	82 ft	23 ft	2300 GPH	1"	13 lbs
WP6520	Viper	196cc	85 ft	26 ft	9500 GPH	2"	54 lbs
WP6530	Viper	196cc	82 ft	26 ft	13,000 GPH	3"	58 lbs

EARTH AUGER POWERHEADS

1-PERSON	ENGINE	CC RATING	GEAR RATIO	MAX RPM	WEIGHT	AUGER DIAMETERS
E43	Viper	43cc 2-cycle	30:1	250	19 lbs	2,3,4,6,8,10
9000E	Tecumseh	85cc 2-cycle	16:1	280	26 lbs	2,3,4,6,8,10

2-PERSON	ENGINE	TYPE	GEAR RATIO	MAX RPM	WEIGHT	AUGER DIAMETERS
9800H	Honda	5.5 hp	30:1	121	54 lbs	2,3,4,6,8,10,12,14
9800B	Briggs & Stratton	6.75 ft-lbs Gross Torque	30:1	121	52 lbs	2,3,4,6,8,10,12,14

LOG SPLITTERS

MODEL	ENGINE	TYPE	MAX SPLITTING FORCE	MAX LOG LENGTH	WEDGE	BALL HITCH	WEIGHT
W2813V	Viper	389cc	27 tons	24"	7" high	2"	580 lbs
W2860B	Briggs & Stratton	8.50 ft-lbs Gross Torque	27 tons	24"	7" high	2"	570 lbs
W2265V	Viper	196cc	22 tons	24"	7" high	2"	550 lbs
W1000	Electric	1.75 hp	4 tons	20"	5" high	NA	93 lbs
W1265V	Viper	196cc	12 tons	21"	7" high	Pin Style	120 lbs

CHIPPERS/SHREDDERS

MODEL	ENGINE	TYPE	HAMMERS	ROTOR	HOPPER	WEIGHT
9010400	Briggs and Stratton	305cc 14.50 ft-lbs Gross Torque	2 "J" and 2 Tri	steel	16 3/4" x 13 1/4"	133 lbs
9060300	Briggs and Stratton	8.50 ft-lbs Gross Torque	2 "J" and 2 Tri	steel	16 3/4" x 13 1/4"	97 lbs

Where to buy. Visit GetEarthquake.com or call 800-345-6007 for a dealer near you.

49 state compliant. Not for sale in California.

Specifications are approximate and subject to change without notice.

Earthquake®

Quality Doesn't Have To Be High Priced.

Actual email from Chip in Oklahoma:

"I just purchased [an MC43 Mini Cultivator in] Stillwater, OK. [I was impressed with the quality of this at such a great price.] This thing is awesome. I have used my inlaws [high priced cultivator from another manufacturer] and your Earthquake [cultivator] blows it away. Thanks for the great product and price!!"

**Chip Palmer
Stillwater, OK**



WE HAVE SOMETHING FOR EVERY SEASON.

From gardening to hunting to ice fishing, Ardisam offers a wide variety of outdoor products and accessories to add comfort and convenience. Visit www.ardisam.com to find other products to accommodate your outdoor hobbies.

Eskimo®
ICE FISHING GEAR

- Power Ice Augers
- Hand Augers
- Ice Shelters
- Ice Fishing Accessories

RIVERS EDGE™
TREESTANDS

- Ladders
- Climbing Ladders
- Climbing Sticks
- Hang-On Stands
- Climbing Stands
- Ladder Pods

YUKON™
TRACKS

- Hunting Accessories
- ATV Accessories
- Outdoor Apparel

CUMBERLAND
STOVE • WORKS

- Multi-Fuel Pellet Stoves
- Industrial Corn Burning Furnaces

We Make You Our Business, Always.

At Ardisam, we are committed to taking care of the customer. We strive to give you the best product for your best possible outdoor experience. Let us help you find what you need or answer any questions you have about any of our products.

Contact Information

Toll Free: 800-345-6007

Email: info@ardisam.com

Fax: 715-822-2223

WRITE US: Ardisam, Inc.
1690 Elm Street
Cumberland, WI 54829

Your local **Earthquake** distributor is:

Earthquake, Division of Ardisam, Inc. • 800-345-6007



Innovative Outdoor Products Since 1960