



GrowSpan™ Round Economy High Tunnels

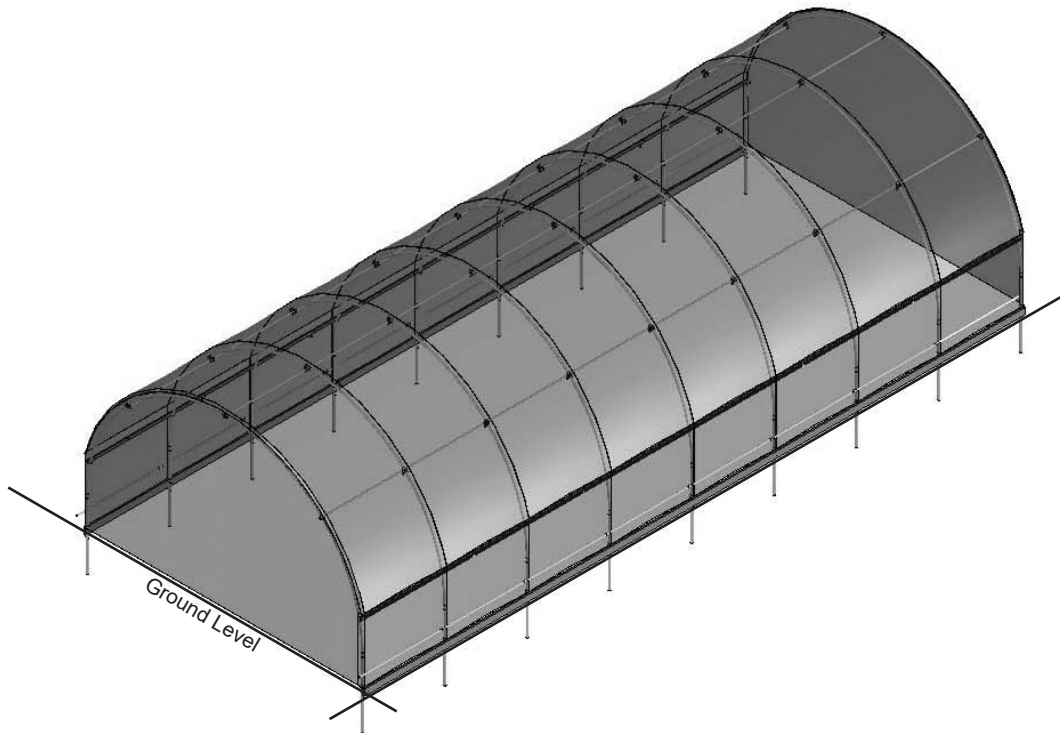

Diagram may show a different but similar model. Economy high tunnels include film roof and film end panels.

©2021 GrowSpan
All Rights Reserved. Reproduction
is prohibited without permission.



WARNING: Cancer and Reproductive Toxicity - P65Warnings.ca.gov

Revision date: 10.25.21

STK#	DIMENSIONS
PB01680R6	20' W x 12' H x 48' L
PB01690R6	20' W x 12' H x 96' L



READ THIS DOCUMENT BEFORE YOU BEGIN

Thank you for purchasing this GrowSpan™ high tunnel. When properly assembled and maintained, this product will provide years of reliable service. These instructions include helpful hints and important information needed to safely assemble and properly maintain the high tunnel. Please read these instructions **before** you begin.

If you have any questions during the assembly, contact Customer Service for assistance.

SAFETY PRECAUTIONS

- Wear eye protection.
- Wear head protection.
- Wear gloves when handling metal tubes.
- Use a portable GFCI (Ground Fault Circuit Interrupter) when working with power tools and cords.
- Do not climb on the high tunnel or framing during or after construction.
- Do not occupy the high tunnel during high winds, tornadoes, or hurricanes.
- Provide adequate ventilation if the structure is enclosed.
- Do not store hazardous materials in the high tunnel.
- Provide proper ingress and egress to prevent entrapment.

ANCHORING INSTRUCTIONS

Prior to assembling this high tunnel, please read the **MUST READ** document included with the shipment.

⚠ WARNING: The anchor assembly is an integral part of the high tunnel construction. Improper anchoring may cause high tunnel instability and failure of the structure. Failing to anchor the high tunnel properly *will void the manufacturer's warranty* and may cause serious injury and damage.

LOCATION

Choosing the proper location is an important step before you begin to assemble the structure.

The following suggestions and precautions will help you determine whether your selected location is the best location.

- Never erect the structure under power lines.
- Identify whether underground cables and pipes are present *before* preparing the site or anchoring the structure.
- Location should be away from structures that could cause snow to drift on or around the building.
- Do not position the high tunnel where large loads such as snow and ice, large tree branches, or other overhead obstacles could fall.

SITE

After choosing a location, proper preparation of the site is essential. Follow the information below.

- *A level site is required.* The site must be level to properly and safely erect and anchor the structure.
- For sites that are not concrete or gravel, placing wood blocks or other suitable supports under each rafter leg helps prevent the pipes from sinking or working into the site.
- Drainage: Water draining off the structure and from areas surrounding the site should drain away from the site to prevent damage to the site, the structure, and contents of the structure.

⚠ WARNING: The individuals assembling this structure are responsible for designing and furnishing all temporary bracing, shoring and support needed during the assembly process. For safety reasons, those who are not familiar with recognized construction methods and techniques must seek the help of a qualified contractor.

ASSEMBLY PROCEDURE

Following the instructions as presented will help ensure the proper assembly of your high tunnel. Failing to follow these steps may result in an improperly assembled and anchored high tunnel and will void all warranty and protection the owner is entitled.

The steps outlining the assembly process are as follows:

1. Verify that all parts are included in the shipment. Notify Customer Service for questions or concerns.
2. Read these instructions, the Must Read document, and all additional documentation included with the shipment **before** you begin assembling the high tunnel.
3. Gather the tools, bracing, ladders (and lifts), and assistance needed to assemble the high tunnel.
4. Check the weather **before** you install the roof cover and any panels (if equipped). Do not install covers or panels on a windy or stormy day.
5. Re-evaluate the location and site based on the information and precautions presented in the documentation included with the shipment.
6. Prepare the site (if applicable).
7. Assemble the frame components in the order they are presented in these instructions.
8. Assemble the frame including the struts (if equipped).
9. Consult the MUST READ document and properly anchor the assembled frame.
10. Install, tighten, and secure the end panel and main cover (if equipped). This applies to fabric covers that stretch over the frame assembly. Your shelter may include roof panels or side panels or both.
11. Read the Care and Maintenance information at the end of these instructions.
12. Complete and return all warranty information as instructed.

REQUIRED TOOLS

The following list identifies the main tools needed to assemble the shelter. Additional tools and supports may be needed depending on the structure, location, and application.

- Tape measure or measuring device
- Fine point marker to mark the location on tubing.
- Variable speed drill/driver (cordless with extra batteries works best)
- Wrench, ratchet and socket (recommended)
- Scissors
- Ropes long enough to reach over the frame.
- Hammers and gloves
- Metal file
- Duct tape
- Box cutter or utility knife
- Ladders, work platforms, and other machinery for lifting designed to work safely at the height of the frame

UNPACK AND IDENTIFY PARTS

The following steps will ensure that you have all the necessary parts before you begin to assemble the shelter frame.

1. Unpack the contents of the shipment and place where you can easily inventory the parts. Refer to the Bill of Materials/Spec Sheets.
2. Verify that all parts listed on the Bill of Materials/Spec Sheets are present. If anything is missing or you have questions, consult the Pictorial Parts Guide and all diagrams for clarification, or contact Customer Service.

NOTE: At this time, you do not need to open the plastic bags containing smaller parts such as fasteners or washers (if equipped).

GROWSPAN™ ROUND ECONOMY HIGH TUNNELS

CUSTOMER-SUPPLIED MATERIALS — Baseboard, Ribbon Boards, & Wood Screws

Baseboards and ribbon boards are optional, but recommended, for buildings with roll-up sides. Materials for baseboards and ribbon boards are *not included* and are *supplied by customer*.

ATTENTION: Fasteners to secure boards to building frame are included. *Recommended* lumber dimensions shown; wider boards can be used if desired. Counter sink holes for 1/4" carriage bolts if bolt length is too short for board thickness.

BASEBOARDS

The baseboard, when installed properly, helps prevent the ground posts from sinking into the ground when anchored. Depending on the building, it also provides a surface to attach struts or other building components.

ATTENTION: Baseboards run the frame length along both sides at ground level. Installation of customer-supplied baseboard is described later in this guide.

RIBBON BOARDS

A ribbon board typically runs a few feet above the ground along the sidewall. It serves as a mounting surface for the u-channel that secures the main cover and roll-up portion of the main cover.

MATERIAL DIMENSIONS

- Baseboards: 2" x 6" (minimum)
- Ribbon Boards: 2" x 4" or 2" x 6" (recommended)

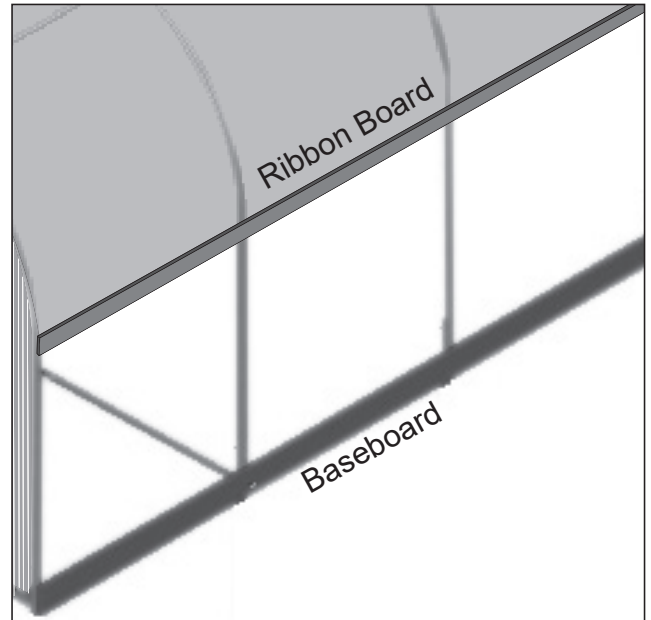

Actual frame may differ from example shown.

IMPORTANT: IF RIBBON BOARDS ARE USED, PURCHASE WOOD SCREWS TO ATTACH THE U-CHANNEL TO THE INSTALLED RIBBON BOARD.

TEK SCREWS ARE NOT WOOD FASTENERS. NEVER USE TEK SCREWS TO SECURE ANY COMPONENT TO WOOD. THEY WILL NOT HOLD.

ANTI-BILLOW ROPE INSTALLATION

TO PREVENT DAMAGE AND POSSIBLE INJURY, INSTALL THE ANTI-BILLOW ROPES IN SHORT LENGTHS ALONG EACH SIDE OF THE FRAME.

DO NOT INSTALL AS A SINGLE LENGTH TIED AT EACH END OF THE BUILDING. DOING SO WILL RESULT IN A LOOSE SIDE PANEL IF THE SINGLE ROPE BREAKS DURING STRONG WINDS.

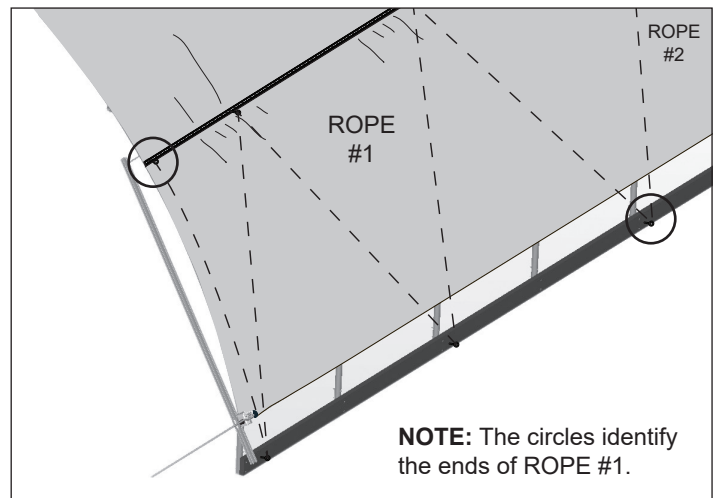

NOTE: The circles identify the ends of ROPE #1.

FRAME ASSEMBLY NOTE

During the assembly of the frame, install a Tek screw through each clamp into the rafter and through each clamp into the purlin.

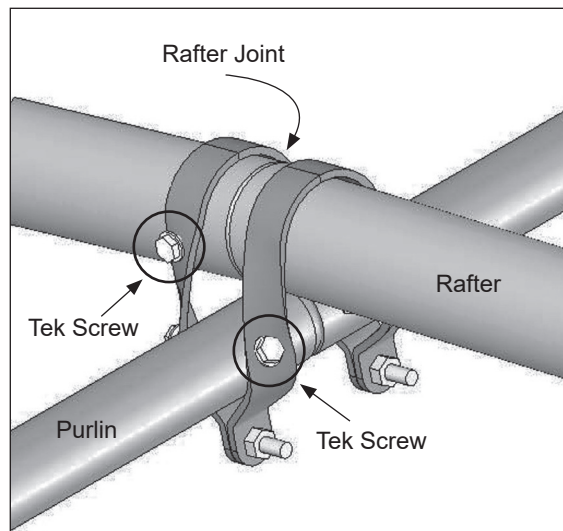

Position all Tek screws so they will not touch the cover material once it is installed.

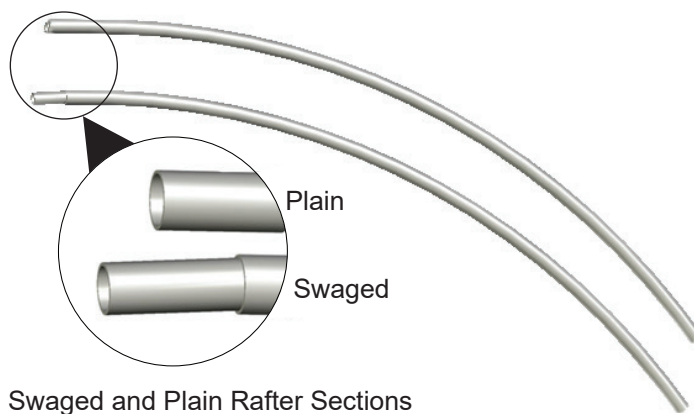

Swaged and Plain Rafter Sections



The following graphics and photos will help you identify the different parts and show you how they are used. (Some parts are not shown.)

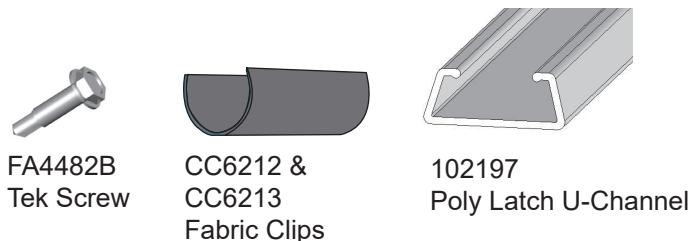

FA4482B
Tek Screw

CC6212 &
CC6213
Fabric Clips

102197
Poly Latch U-Channel



102675
Ground Post



102856
End Clamp



117063 EZ-Snap
Rope Hooks

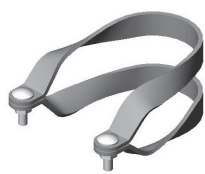

102548
Cross Connector



102198
U-Channel Spring

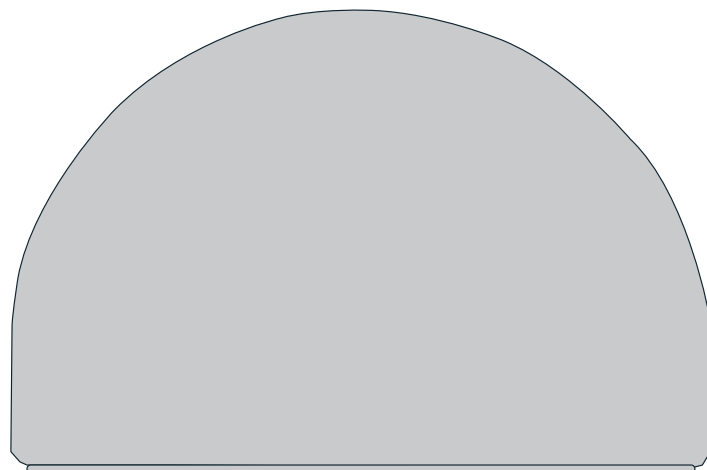

Plain End Panel



Round Economy High Tunnels

OVERVIEW

This section is an overview of the process for assembling your high tunnel. For details, please see section, Assembling the High Tunnel Components. See illustration below to identify main parts of high tunnel.

1. Locate the required parts for each assembly procedure.
2. Assemble the rafters and frame, and square the frame.
3. Prepare and attach end panels.
4. Attach main cover and roll-up side assembly.

ATTENTION: Position purlins evenly during the frame assembly. Use the rafter pipe joints as guides when installing the end clamps, cross connectors, and purlins.

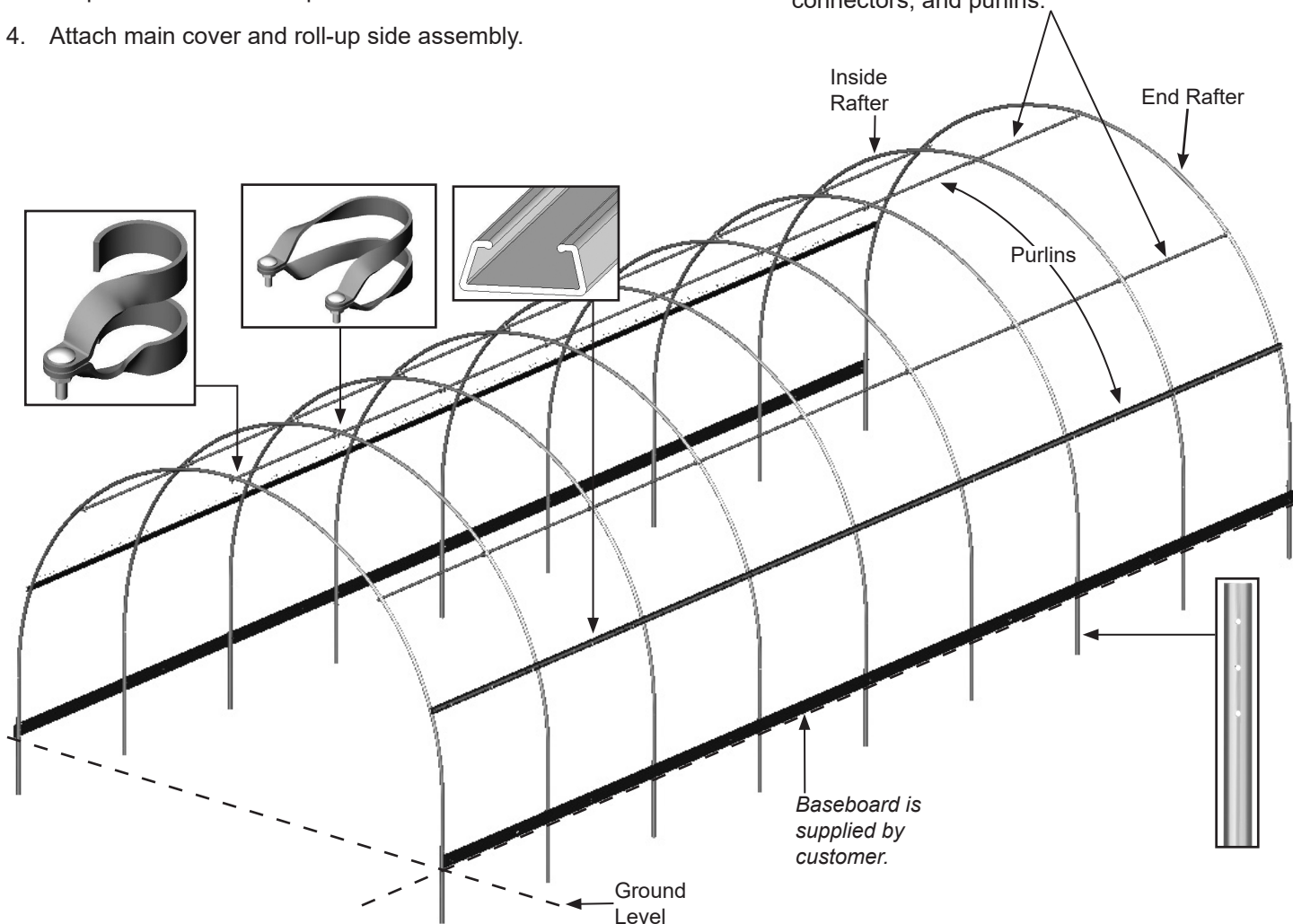

Actual frame may differ from frame shown.

LAY OUT THE BUILDING SITE

After the site is prepared, lay out the building site.

Taking these steps **before** assembling the shelter saves time and ensures that the structure is positioned as desired.

Ground posts must be driven to the proper depth. Width of the shelter is measured from the center of one ground post to the center of the remaining ground post.

SQUARE THE SITE

Gather the parts:

- Ground posts
- 5/16" x 2-1/2" machine bolts
- 5/16" nuts

1. Identify a corner where a ground post will be positioned and drive the first ground post into the ground.

NOTE: Insert the ground post driver into the top of the ground post to protect the post and drive the post into the ground. *The top of the post will be one (1) foot above the finished grade when properly driven.*

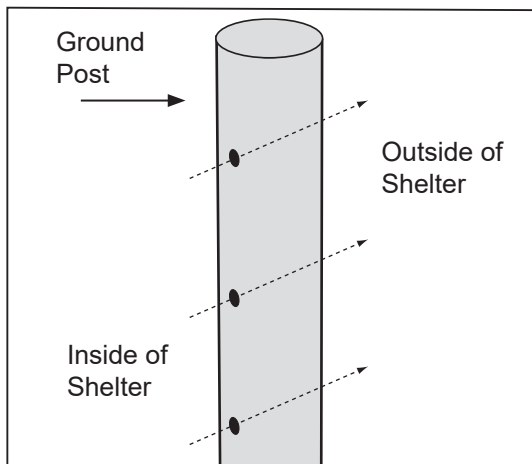

ATTENTION: Position the pre-drilled holes facing to the inside/outside of the shelter so they can be aligned with the bolt holes in the rafter legs.

To align the bolt holes in the ground posts with those in the rafter *after driving the ground posts*, insert a tapered rod or pry bar into a ground post bolt hole and turn the post using the rod or pry bar.

2. After the first corner ground post is in place, string a line the width of the building (center-to-center) and drive the second ground post into the ground just enough to hold it in place.
3. Use a transit or line level to drive the second corner post to the same depth as the first ground post.

4. String a line at least as long as the building from the first stake at 90°.

NOTE: A transit can be used to ensure an accurate 90° angle, or the 3-4-5 rule can be used. Refer to diagram. Using multiples of 3-4-5 such as 6-8-10 or 12-16-20 helps to maintain an accurate 90° angle.

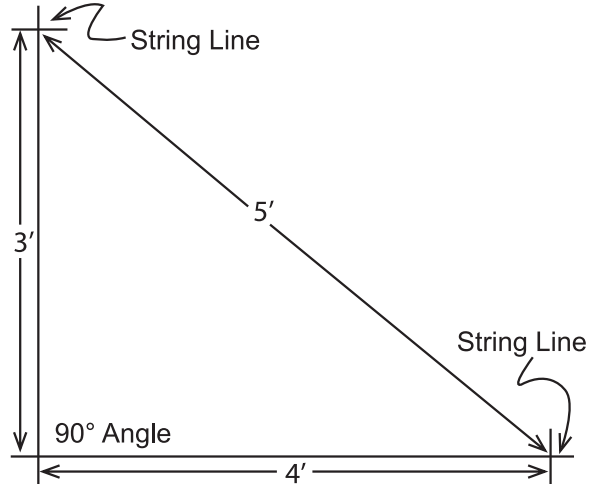

5. After squaring the position of the building, measure the length and drive the next corner ground post.
6. Repeat the same step for the last corner post.

NOTE: The distance measured diagonally between corner posts must be equal for the building to be square.

7. Check all dimensions (and adjust if needed) before driving the remaining posts to the required height.
8. After all corner posts are accurately installed, tie a string line between the tops of the corner ground posts on the same side of the shelter. The string is used to identify the tops of all remaining ground posts. The string must remain tight and level.
9. Use a tape measure to mark the 72" on-center locations of the remaining ground posts.
10. Drive the remaining ground posts into the ground at the required 72" on-center width and the height identified by the string.

NOTE: Verify that the holes in the ground posts are in the proper position and that each post is plumb and driven to the correct depth.

After the rafters have been assembled, the rafter ends are secured to the ground post using the upper hole.

The bottom two (2) holes on the ground post are used for the optional baseboards.

11. Continue with the **Rafter Assembly** steps that follow.

GROWSPAN™ ROUND ECONOMY HIGH TUNNELS

ASSEMBLING THE HIGH TUNNEL FRAME COMPONENTS

NOTE: Assistance is required to assemble the high tunnel frame.

RAFTER ASSEMBLY

Gather the parts:

- Rafter pipe #20R1601
- Rafter pipe #20R1602
- Rafter pipe #166S027D
- End clamps
- Tek screws
- Nut setter (3/8" x 2-9/16 magnetic)

Rafter Assembly Procedure

Each rafter assembly consists of six (6) rafter sections: three (3) swaged sections, one (1) non-swaged (plain) section, and a pair of swaged extensions.

1. Select the six (6) pipes needed to assemble a rafter and arrange these on a flat surface as shown below for assembly.

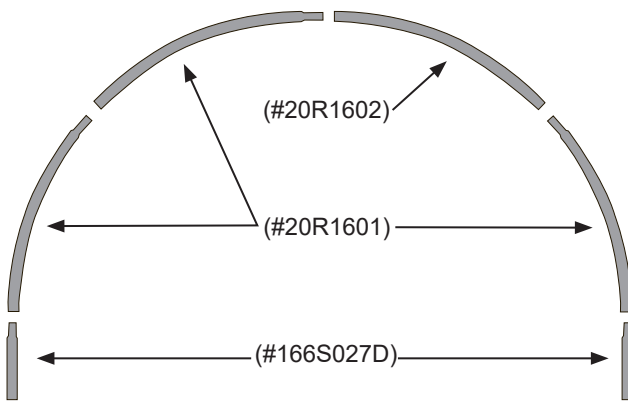

2. Slide the swaged portion of each rafter pipe into the plain end of the pipe as shown.

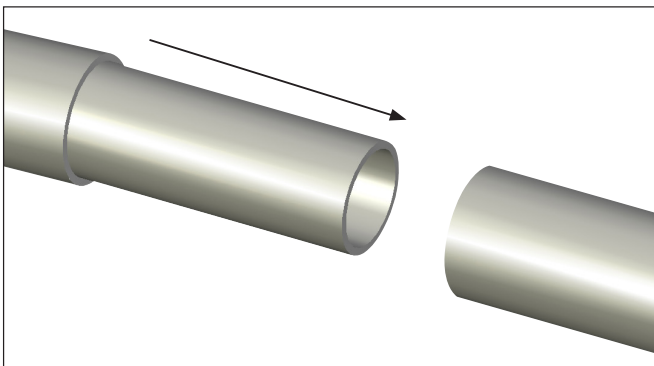

3. With the main rafter pipes seated at each joint and the rafter positioned on a flat surface, secure each joint with a single self-tapping Tek screw.

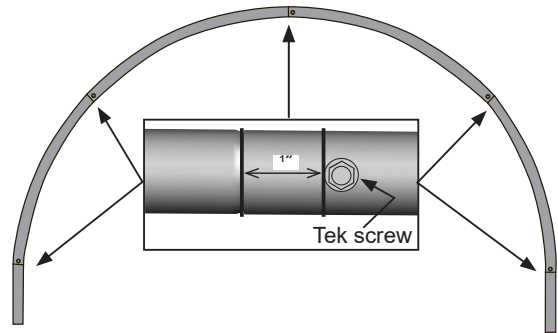

ATTENTION: Do not secure the drilled leg pipes until rafter is secured to the ground posts. This allows holes in rafter legs to be aligned with those in ground post. Install the screws so they will not touch the cover once it is installed. This is typically on the backside of the rafter, which will be the surface visible from the *inside* of the high tunnel once the frame is assembled.

4. Assemble rafters as described and continue with the additional steps to complete the assembly of the two (2) end rafters.

END RAFTER ASSEMBLY

In addition to the steps in the previous procedure, complete the following steps *for the two (2) end rafters only*.

1. Take one of the assembled rafters and place it on a flat surface.
2. Slide three (3) end clamps onto the rafter in the locations noted below. (Do not secure the clamps to the rafter at this time. These clamps will be repositioned during the frame assembly when the purlins are added.)

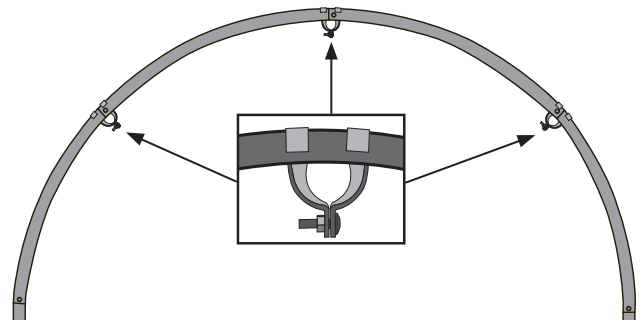

NOTE: Position all clamps as shown. Use a piece of duct tape (if desired) to keep each clamp from sliding when the rafter is lifted into position.

View of the end rafter and clamps as shown from the *outside* when the frame is assembled.

3. Repeat the same procedure for the final end rafter.
4. Continue with the **Frame Assembly** instructions that follow.

FRAME ASSEMBLY

Gather the parts:

- All rafter assemblies
- Pipe 1.315" x 75" swaged (#131S075)
- Pipe 1.315" x 73.5" plain (#131P0735)
- 5/16" x 2-1/2" machine bolts and 5/16" nuts
- Lifts, ladders, and assistants

Frame Assembly Procedure

1. Using the proper lifts and with assistance, carefully stand the first end rafter assembly and place the leg pipes into the first set of ground posts.

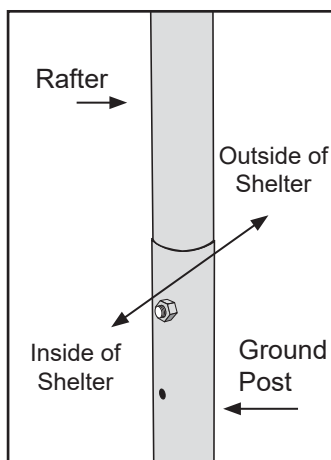

IMPORTANT: Brace the first rafter in position as needed to keep it from moving. Bracing is removed *after* additional rafters are installed and secured to the other rafters.

2. Secure the leg pipes to the ground posts using the 5/16" x 2-1/2" machine bolts and nuts.
3. Place an interior rafter assembly into a second set of ground posts. Secure the leg pipes to the ground posts as previously described.
4. Position two (2) cross connectors near the top of the interior rafter assembly as shown below.

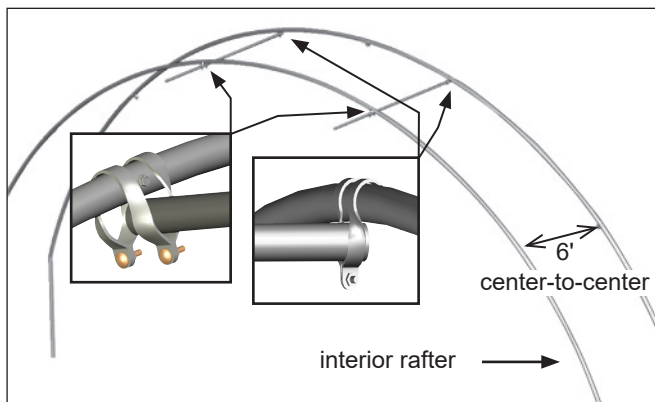

5. Take two (2) swaged 75" purlin sections and insert each through an upper clamp on the end rafter and through the cross connectors near the top of the interior (or second) rafter as shown above.

6. Verify that both rafters are plumb and properly spaced (6' on center).
7. Tighten the upper cross connectors on the interior rafter and tighten the end clamps near the top of the end rafter to secure the first purlin pipes.

NOTE: Do not allow the purlin to extend beyond the end of the end rafter. See diagram below.

8. Continue adding rafters and purlin pipe until the frame is assembled. Secure all purlin splices using Tek screws. See Step 10.

NOTE: Each purlin assembly consists of 1.315" x 75" (#131S075) swaged pipes (number is determined by shelter length) and one (1) 1.315" x 73.5" (#131P0735) plain pipe.

9. Finish each purlin run using the plain, shorter pipe (#131P0735), and use the final end rafter to complete the assembly.

NOTE: If the last end rafter is plumb and the purlin run extends beyond the end of the rafter, cut the last section of purlin pipe to the required length. Typically purlin pipes *do not* require cutting. *Verify that you have the correct plain pipes before you decide to cut any pipe to complete the purlin runs.*

CAUTION: To prevent cover damage, the ends of the purlins should extend no more than 1/2" past the end clamp. Position the bolt side of the end clamps toward the "inside" of the shelter (the same side as the purlin).

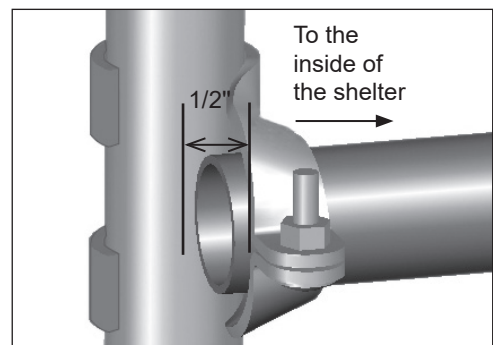

10. Once all rafters are set and all purlins are in place and secured, return to each pipe splice of each purlin run and install a Tek screw through the pipes to secure the joints if this was not completed during assembly.

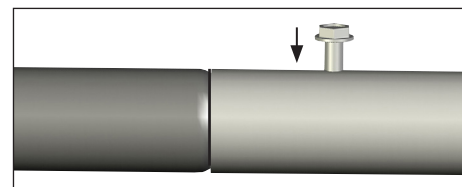

11. Return to each rafter and, using Tek screws, secure the joint between the lower rafter legs (drilled pipe) and the upper rafter pipes and continue with the following procedure.

GROWSPAN™ ROUND ECONOMY HIGH TUNNELS

BASEBOARD INSTALLATION (RECOMMENDED)

Gather the parts:

- Treated or recycled plastic lumber (supplied by customer). **Recommended: 2" x 6"**.
- 1/4" x 4" carriage bolts and nuts (may not work for baseboards with a thickness greater than 1-1/2")

NOTE: The following procedure describes one way to install the recommended baseboards. The size and type of the baseboard you choose may require the use of alternative steps. When properly installed, baseboards run the length of the frame.

On the outside of the frame, attach the first baseboard to the ground posts using the 1/4" x 4" carriage bolts (FAH009B) and nuts (FALB01B). Continue adding baseboards to complete the first run. Splices are made between posts as shown. Use a short section of baseboard to secure separate baseboards at a splice.

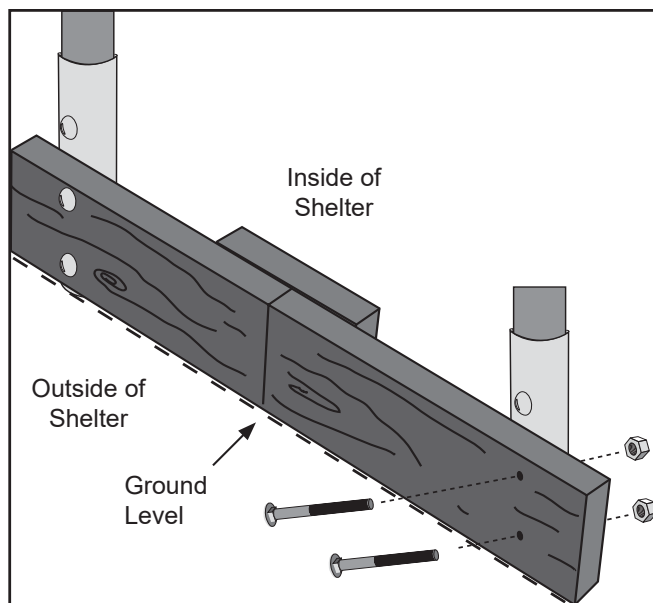

NOTE: The boards should be at ground level or slightly into grade to prevent the shelter from sinking and to create a seal along the bottom. After installing the baseboards, continue with these instructions.

This baseboard is *not included* with the shipment and must be supplied by the customer. Treated or recycled plastic lumber works well for a baseboard.

Recommended dimension: 2" x 6".

FINISH ROUGH EDGES

Gather the parts:

- Duct tape (supplied by customer)
 - Metal file
1. Check for any sharp edges on the frame and file them smooth so they will not cut the cover.
 2. Apply two layers of heavy duct tape on all pipe connections and clamps that may contact the cover.

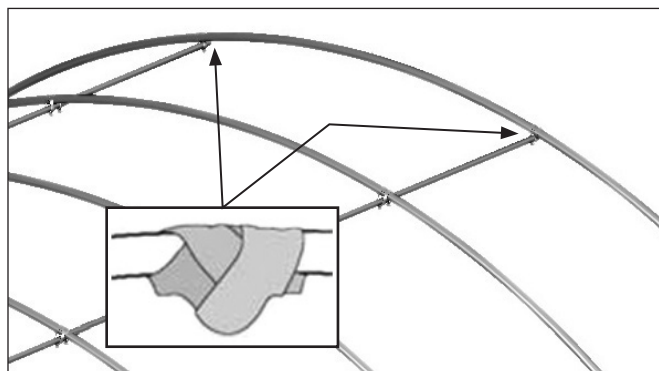

ANCHOR THE ASSEMBLED FRAME

At this point, anchor the high tunnel frame. Consult the **MUST READ** document for anchoring information and suggestions. Please call customer service at 1-800-245-9881 for additional anchoring information.

CAUTION: The anchor assembly is an integral part of the high tunnel construction. Improper anchoring may cause instability and failure of the structure to perform as designed. Failing to anchor the shelter properly will void the manufacturer's warranty and may cause serious injury and damage.

ATTACH END PANELS

CAUTION: To prevent damage, do not install end panels on a windy day.

Gather parts:

- 28' x 28' end panel film (108657) cut in half.
- Fabric clips #CC6213 (Divide quantity in half.)
- Tape measure and scissors

Assembly Procedure

1. Cut end panel film (108657) in half to create two end panels (14' x 28' each) — one for each frame end.
2. Spread one end panel film out on ground at desired end of frame and center as needed.
3. With proper lift (or ladders), pull end panel up and over top of end rafter.
4. Secure end panel to backside of end rafter at top, center position using a fabric clip and Tek screw.
5. Moving outward in both directions, continue attaching fabric clips to secure end panel to rafter. Evenly space fabric clips and work toward ground.

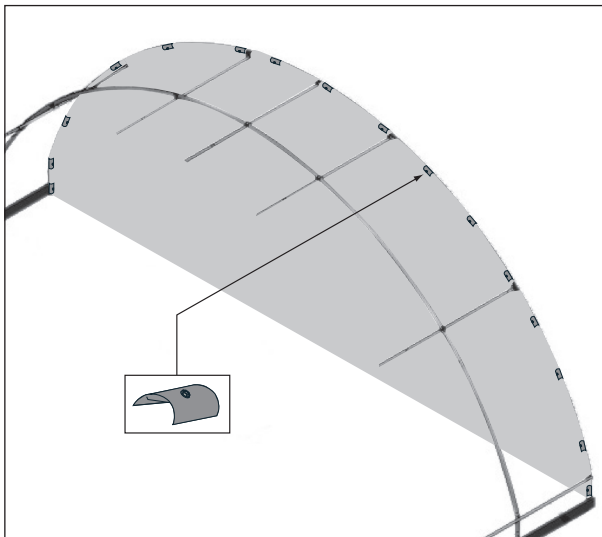

Shelter shown above may be a different model. Drawing used for illustration only. Actual number of clips may differ.

ATTENTION: Use half of the clips to secure end panel

6. Repeat steps to secure remaining end panel to frame using remaining half of fabric clips.

NOTE: Trim excess film material after installation. Do not trim too close to fabric clips; allow at least 6" to remain beyond clips.

MAIN COVER INSTALLATION

After the end panels are installed, install the main cover. The steps to install the main cover include:

1. Attach poly latch U-Channel (102197) along the high tunnel sides and tops of the high tunnel end rafters using FA4482B Tek screws.
2. Pull main cover over the frame.
3. Attach the main cover to the end rafters using the poly latch springs.
4. Stretch and attach main cover to the sides of the frame.
5. Install roll-up side kits and test the operation of the twist-of-the-wrist assembly.

INSTALL POLY LATCH U-CHANNEL (102197)

1. Measure the desired height (4'-5') to identify the top of the roll-up sides. Attach the poly latch channel at approximately 4'-5' above the ground on both sides of the frame.

RECOMMENDED: Attach a ribbon board (2" x 4" or 2" x 6") to the rafters and then attach the poly latch U-channel (102197) to the ribbon board using customer-supplied wood screws.

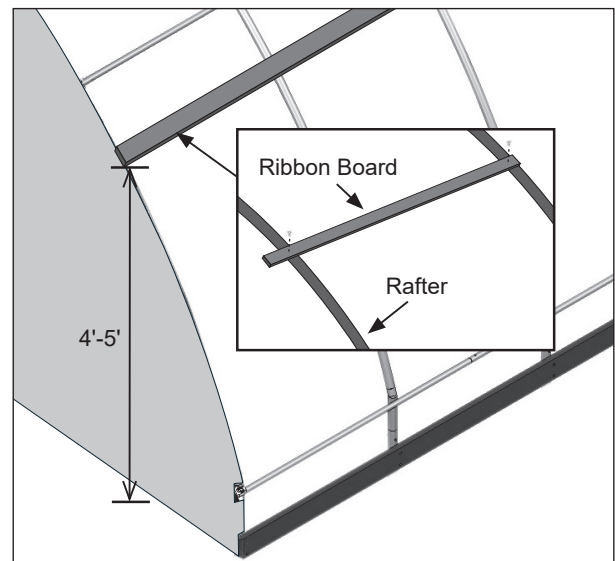

NOTE: Ribbon board and baseboard (recommended) shown in the diagram above are not included and are supplied by the customer. Use the supplied FAH009B (1/4" x 4") carriage bolts and FALB01B (1/4") nuts to secure the ribbon board and U-Channel to the rafter. **Use customer-supplied wood screws to secure U-channel to ribbon board. Do not use Tek screws to attach U-Channel to wood.**

NO RIBBON BOARD: Attach one section of the poly latch U-Channel to the side of the frame using Tek screws. Attach U-Channel flush with the outside edge of the end rafter at each end of the assembled frame.

GROWSPAN™ ROUND ECONOMY HIGH TUNNELS

INSTALL POLY LATCH U-CHANNEL (Continued)

- Continue to attach the U-Channel sections to the rafters (or ribbon board if used) and work toward the other end of the frame. Cut the last section of U-Channel to the required length so that it is flush with the outside edge of the end rafter.



Space below is reserved for customer notes.

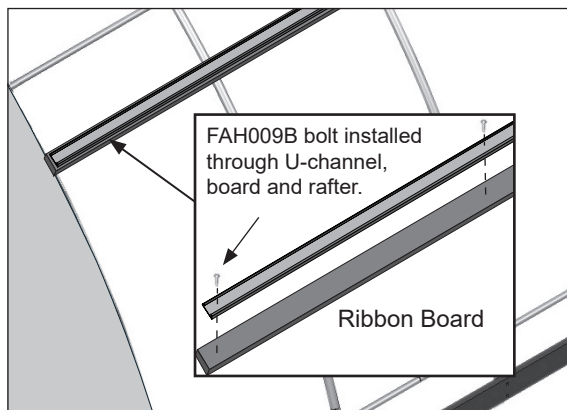

NOTE: Inset shows the use of a ribbon board. U-channel can be attached directly to rafters using FA4482B Tek screws when ribbon board is not used.

- Repeat these steps for the remaining side.
- After attaching the poly latch U-Channel to the sides of the frame, use Tek screws to attach the U-Channel to the top of one end rafter. **Space screws at 24"**.

ATTENTION: The poly latch U-Channel will bend with the curve of the rafter as it is attached. The U-Channel runs from the poly latch U-Channel attached to one side of the frame to the U-Channel attached to the other side of the frame.

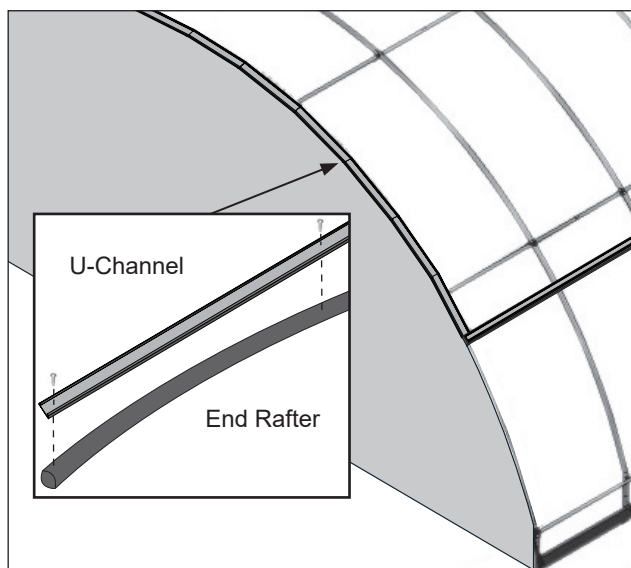

- Repeat the steps to attach the U-Channel to the top of the remaining end rafter and continue with the next procedure.

INSTALL CORNER BAFFLES

If you do not want corner baffles installed, skip this section and continue with the next page. Corner baffles for roll-up sides can be installed later; however, it is easier to install before installing cover, roll-up panels, and anti-billow ropes.

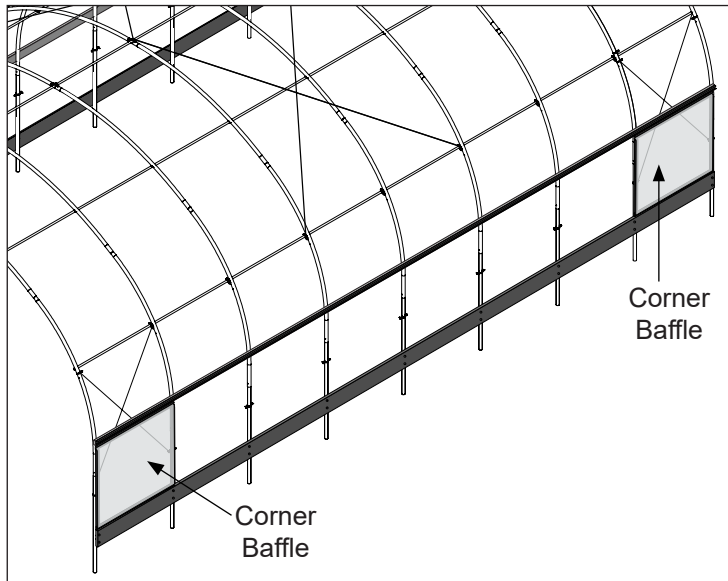

REQUIRED PARTS:

- 102197 U-channel
- 102198A Poly-Coated Spring Wire
- 108654 6' Wide 6 MIL Film
- FA4482B Tek Screws

Complete these steps to install a baffle at each corner of the assembled frame.

1. Locate four (4) pieces of 102197 single u-channel, additional 102198A spring wire, and the 108654 roll of 6 mil film.
2. At one corner, cut and attach the 102197 u-channel to the end rafter and first interior rafter as shown. Install these horizontal runs of single u-channel above the baseboards and below the single u-channel.

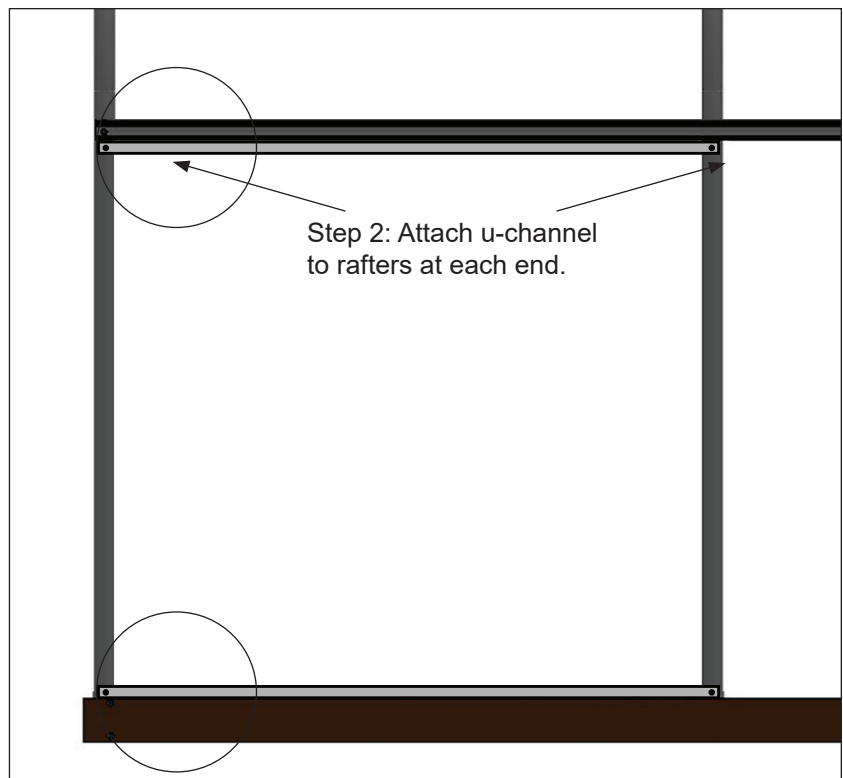
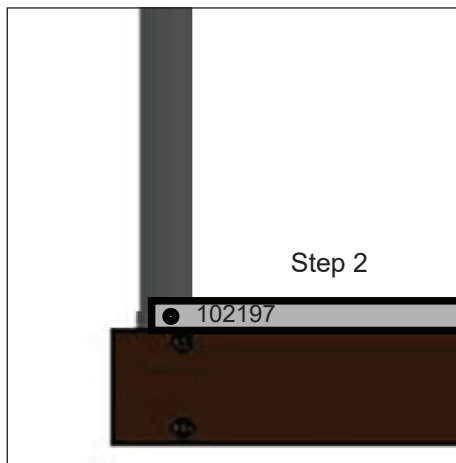
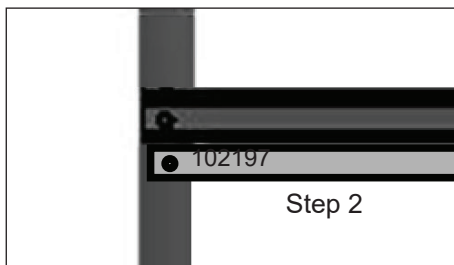

GROWSPAN™ ROUND ECONOMY HIGH TUNNELS

INSTALL CORNER BAFFLES (continued)

3. Measure the distance between the upper and lower single u-channel installed in Step 2. Cut two additional u-channel sections to this length and attach these vertical runs to the end rafter and interior rafter. *Space Tek screws (FA4482B) approximately 12" on-center. Vertical channel runs may consist of multiple small lengths of available u-channel.*

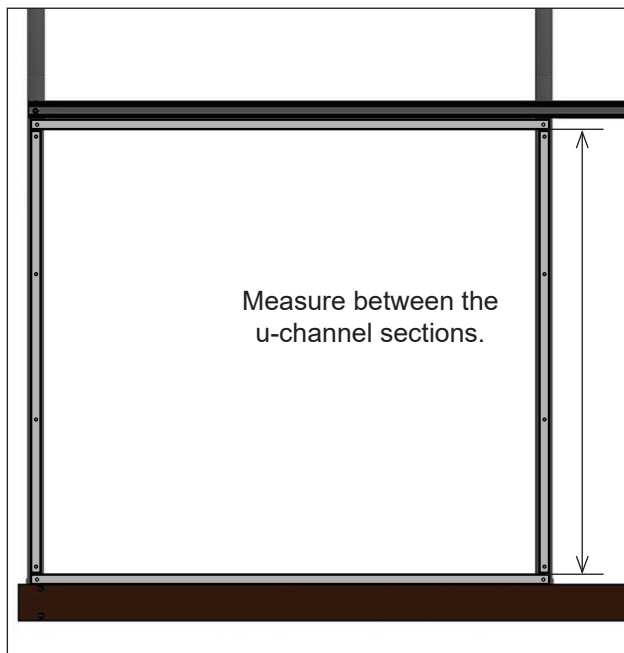

4. Take the 108654 roll of 6 mil film and cut a piece to cover the end bay opening framed by the single u-channel. Roll out the film and measure length to determine the best way to cut the film. You need four (4) identical panels from the film roll.
5. With assistance, secure the film panel in the u-channel using the 102198A wire spring.

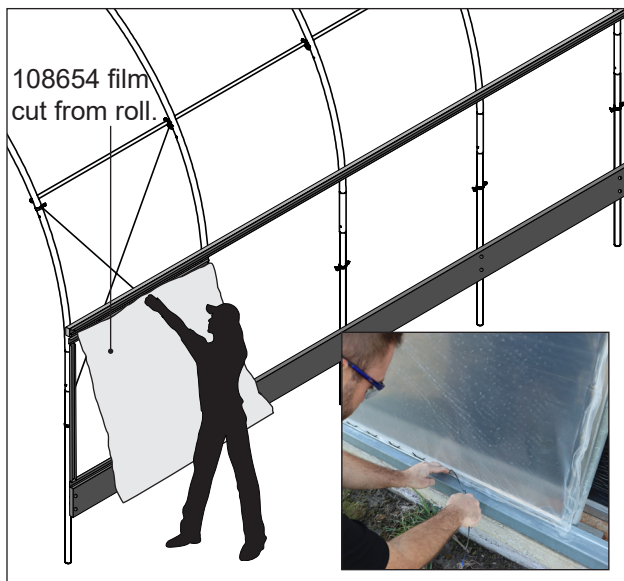

6. Trim the film as needed and repeat the steps to install all remaining corner baffles.
7. After installing all baffles, continue with the next procedure.

INSTALL MAIN COVER

Gather the parts:

- Main cover
- Ropes long enough to reach over the frame (provided by customer)
- U-Channel spring
- Box cutter or utility knife

Assembly Procedure

After the poly latch U-Channel is attached to the frame, unpack the main cover and pull into place. Ropes or straps are typically used to pull the main cover onto and over the frame.

⚠ WARNING: To prevent damage to the cover and to prevent serious personal injury, DO NOT attempt to install the main cover on windy or stormy days.

1. Unpack the main cover and position it at the base along one side of the frame.
2. Make small holes along the edge of the cover at evenly spaced intervals and tie rope to the cover. (The length of the cover determines the number of holes that are needed to attach the ropes.)

NOTE: The ropes must be long enough to reach over the top of the building to the other side. Long buildings will require additional ropes to prevent tearing the main cover when it is pulled into place.

3. After tying the ropes to the main cover, throw the ropes over the top of the frame and pull the cover into place. Cover must be centered side-to-side and end-to-end.

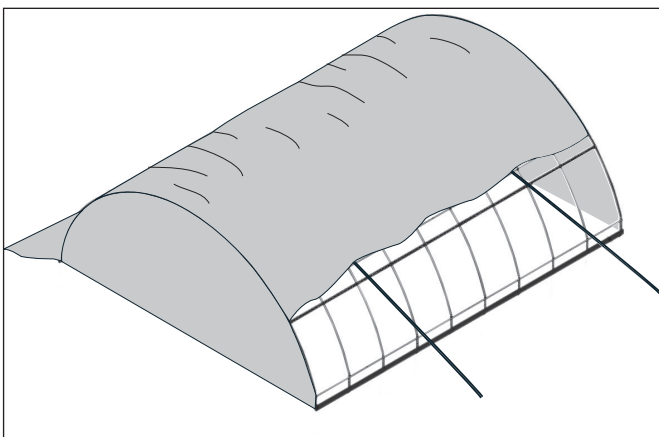

Shelter shown above may be a different length than actual shelter.

IMPORTANT: To prevent damage to the main cover during installation, additional personnel and lifts may be needed.

4. Once the main cover is in place and centered on the frame, begin at the peak of one end rafter and install the wire spring into the U-Channel to secure the cover.

ATTENTION: Center the main cover front to back and side-to-side to ensure that enough cover material is present to lock into the U-Channel. *The excess cover along each side is rolled up when the roll-up side assemblies are installed.*

The rope can remain in place to temporarily secure the cover if needed. Remove the ropes as the cover is secured to the frame.

Photos show installing the spring into the U-Channel on the outside of a frame. The process is the same for the U-Channel attached to the top of the end rafters.

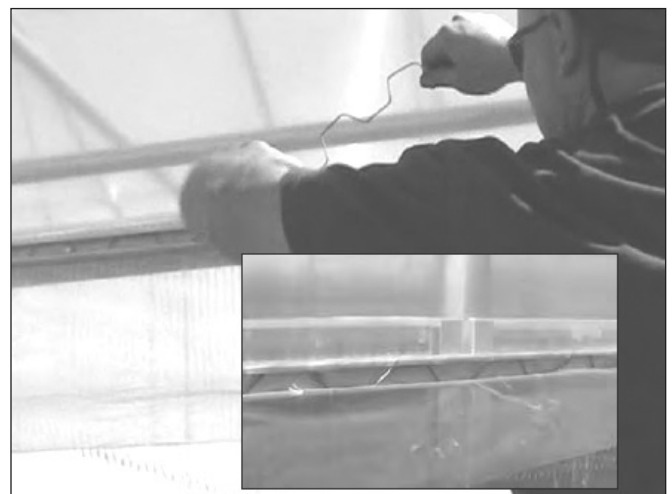

5. Continue adding the spring into the U-Channel at the top of the first end rafter. Ensure that an even amount of the cover is exposed and maintained along the edge of the frame as it is attached.

NOTE: The cover material is cut longer/wider than is required to cover the frame. For easier anchoring, allow approximately 10" to extend past the edge of the end rafter as the cover is anchored in place.

6. Continue down both edges of the first end rafter until the entire length of the end of the main cover is secured in place.
7. Stretch the cover to the other end of the building and repeat the steps to secure the main cover in the U-Channel.

NOTE: Pull the cover tight as the spring is inserted into the U-Channel.

GROWSPAN™ ROUND ECONOMY HIGH TUNNELS

INSTALL MAIN COVER (continued)

8. After the cover is stretched end-to-end and secured using the spring and U-Channel, move to one side of the frame and repeat the steps to anchor the main cover to the first side.

Begin at one end of the U-Channel and work toward the other. It is also possible to begin at the middle of each side and work toward each end.

NOTE: Maintain an even length along the side. The final stretching of the cover takes place when the last side is secured.

9. After securing the first side, move to the remaining side and secure it in place.

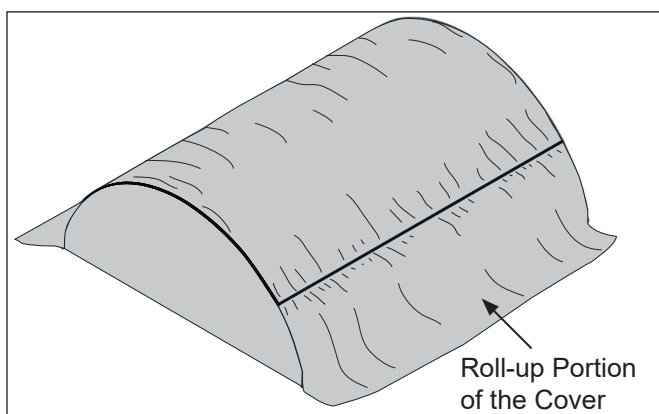

IMPORTANT: DO NOT REMOVE TOO MUCH OF THE EXCESS COVER MATERIAL AT EACH END. Some excess main cover material—the material that extends beyond the end rafters—should remain in place. If the main cover needs stretched in the future, remove the spring from the U-Channel, grasp the excess material, pull the cover tight, and reinstall the spring.

The excess material along the sides is rolled up in the roll-up side assembly.

10. Once the main cover is installed and secured in the U-Channel, continue with the **Install the Roll-up Side Assemblies** procedure.

INSTALL ROLL-UP SIDE ASSEMBLIES

The instructions below describe how to install a single roll-up sidewall assembly for one side of the frame. The procedure is repeated for the remaining side.

The procedures to install the roll-up side include the following:

1. Assemble the roll-up side conduit.
2. Attach the roll-up conduit to the bottom of the main cover.
3. Assemble and install the crank assembly.
4. Install the Anti-Billow Rope system.
5. Test the operation of the roll-up side.

ASSEMBLE THE ROLL-UP SIDE CONDUIT

Gather the parts:

- Pipe 1.315" x 75" Swaged 17 GA (#131S075)
- Pipe 1.315" x 73.5" Plain 17 GA (#131P0735)
- Tek screws

The roll-up side conduit assembly is attached to the bottom of the roll-up side cover material. This assembly runs the length of the frame and serves as the center pipe that the roll-up cover wraps around when it is opened to ventilate the shelter. *This conduit is identical to the purlins that were assembled and attached to the frame.*

Complete these steps to assemble the roll-up side conduit.

1. Locate all sections of pipe needed to assemble the cover conduit.
2. Insert the swaged end of each pipe into the plain end of another pipe until the conduit is assembled.
3. Secure each pipe joint with a Tek screw.

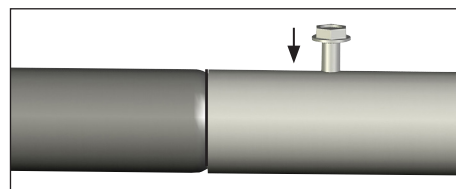

4. Place the assembled conduit at the base of the side where the end of the main cover is located.

NOTE: Duct tape Tek screws to prevent damage to main cover.

5. Continue with the procedure that follows to attach the conduit to the main cover.

INSTALL CRANK ASSEMBLIES

Gather the parts:

- Pipe 1.315" x 73.5" plain (#131P0735)
- Spin handle (#103395)
- Universal joint (#103396)
- Remaining #CC6212 fabric clips (half for each side)

After all end panels are attached and the main cover is secured to the frame, attach the crank assemblies for the roll-up sides.

Assembly Procedure

1. Unfold the remaining portion of the main cover (if needed) and evenly stretch it out on the ground along the frame.
2. Working from *the inside the frame*, roll the assembled cover conduit onto the edge of the main cover.

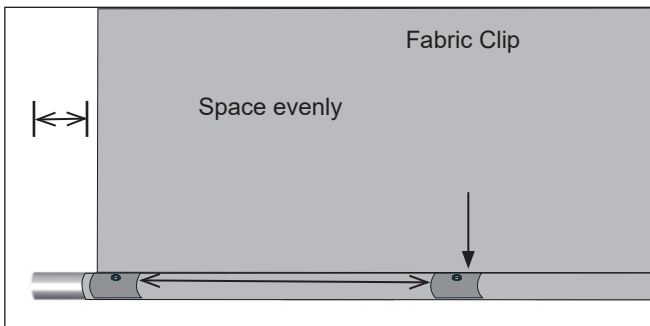

ATTENTION: A few inches of the conduit should extend beyond the edge of the cover, this is where the crank will be attached. See diagram above.

3. Evenly space the fabric clips to secure the main cover to the cover conduit.
4. Attach the universal joint to the conduit in the pocket using a Tek screw to secure the connection.

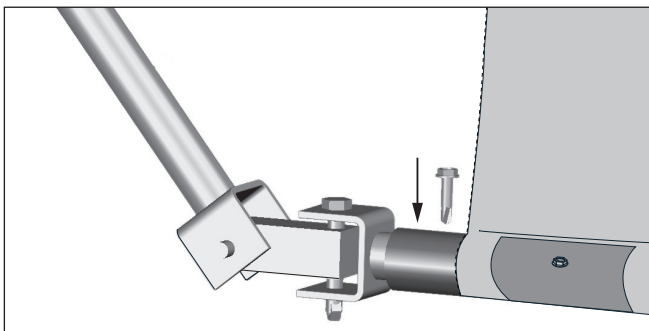

5. Secure one (1) 73.5" plain pipe to the remaining end of the universal joint using a Tek screw.

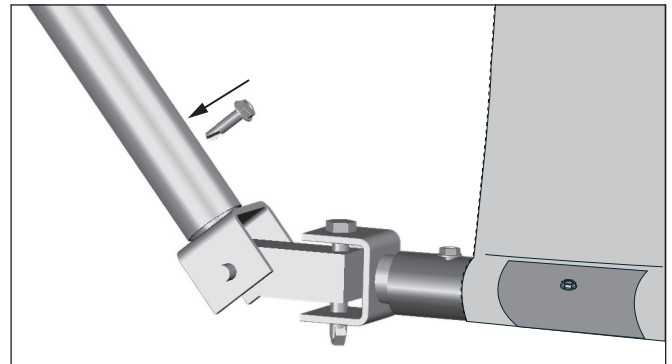

NOTE: This extension pipe can be trimmed to the desired length.

6. Add the spin handle to the extension pole and secure the connection with a Tek screw.



7. Repeat the steps to secure the remaining cover conduit to the main cover.
8. Continue by installing the anti-billow ropes.

GROWSPAN™ ROUND ECONOMY HIGH TUNNELS

INSTALL ANTI-BILLOW ROPES

ANTI-BILLOW ROPE INSTALLATION

TO PREVENT DAMAGE AND POSSIBLE INJURY, INSTALL ANTI-BILLOW ROPES **IN SHORT LENGTHS** ALONG EACH SIDE. DO NOT INSTALL AS A SINGLE LENGTH TIED AT EACH END. DOING SO WILL RESULT IN A LOOSE SIDE PANEL IF SINGLE ROPE BREAKS. **CONSULT THE SIDE PROFILE DIAGRAM FOR YOUR FRAME LENGTH IN THE QUICK START SECTION FOR ROPE PATTERN AND ROPE HOOK LOCATIONS.**

Follow these general steps to attach the 117063 rope hooks, FA2061 eyebolts, and install the anti-bilow ropes:

1. Determine the location of rope hooks, eyebolts, and the number of anti-bilow ropes for each side using the Side Profile diagram in the Quick Start section for your frame length.
2. Attach the 117063 rope hooks using wood screws for wood and Tek screws for metal. Be sure to note where one rope stops and the next rope begins.
3. Take the CC5525 (1/4") rope and install it in short lengths along each side. Pull tight to keep panels in place.
4. Test the operation of the roll-up side.
5. Repeat to install the anti-bilow rope for the remaining side once the panel is installed.
6. With all anti-bilow ropes installed, continue with the next page.

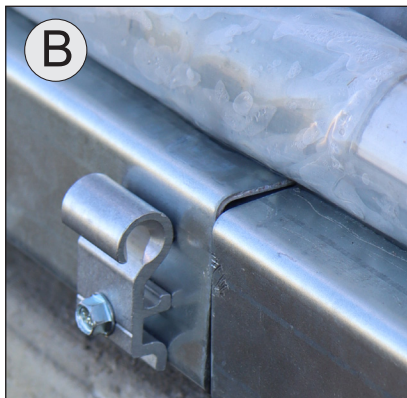
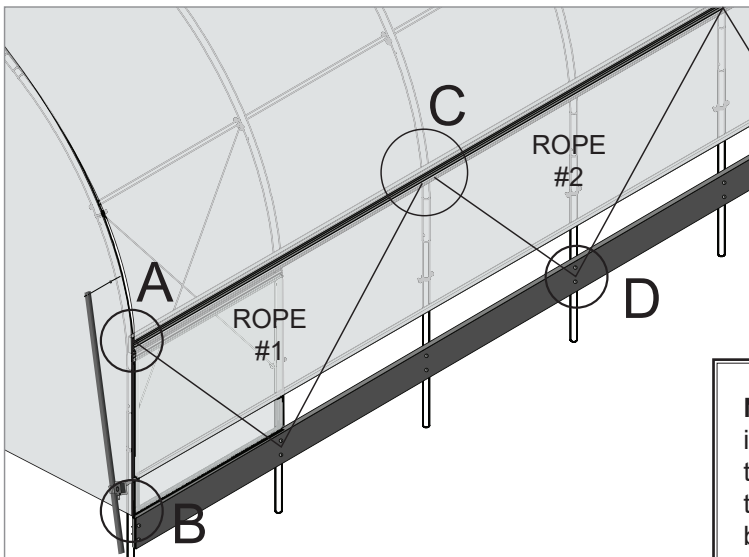

NOTE: In those instances when two ropes terminate at the baseboard or lower position (D), install the rope snaps and rope as shown in these photos.

Photos show using optional hat channel for baseboards.



SHELTER CARE AND MAINTENANCE

Proper care and maintenance of the shelter is important. Check the following items periodically to properly maintain the shelter:



Space below is reserved for customer notes.

- Regularly check the main cover and panels (if equipped) to see that these remain tight and in proper repair.
- Check connections and all fasteners to verify that they remain tight.
- Do not climb or stand on the frame at anytime.
- Remove debris and objects that may accumulate on the cover. Use tools that will not damage the cover when removing debris.
- Remove snow to prevent excess accumulation. Use tools that will not damage the cover when removing snow.
- Check the contents of the high tunnel to verify that nothing is touching the cover or the side panels that could cause damage.
- Check the anchoring system to ensure that all components are tight and in good repair.
- If the shelter is moved, inspect all parts and connections before reassembling.
- For replacement or missing parts, call 1-800-245-9881 for assistance.

GROWSPAN™ ROUND ECONOMY HIGH TUNNELS



QUICK START GUIDE

20' Wide Round Economy High Tunnels

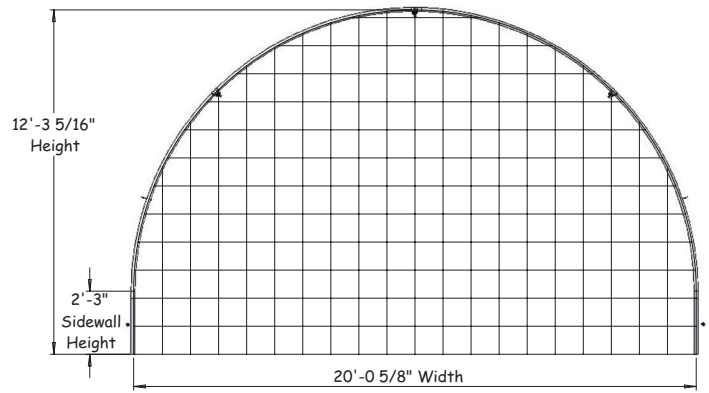

FRONT
Grid Represents 12" Squares

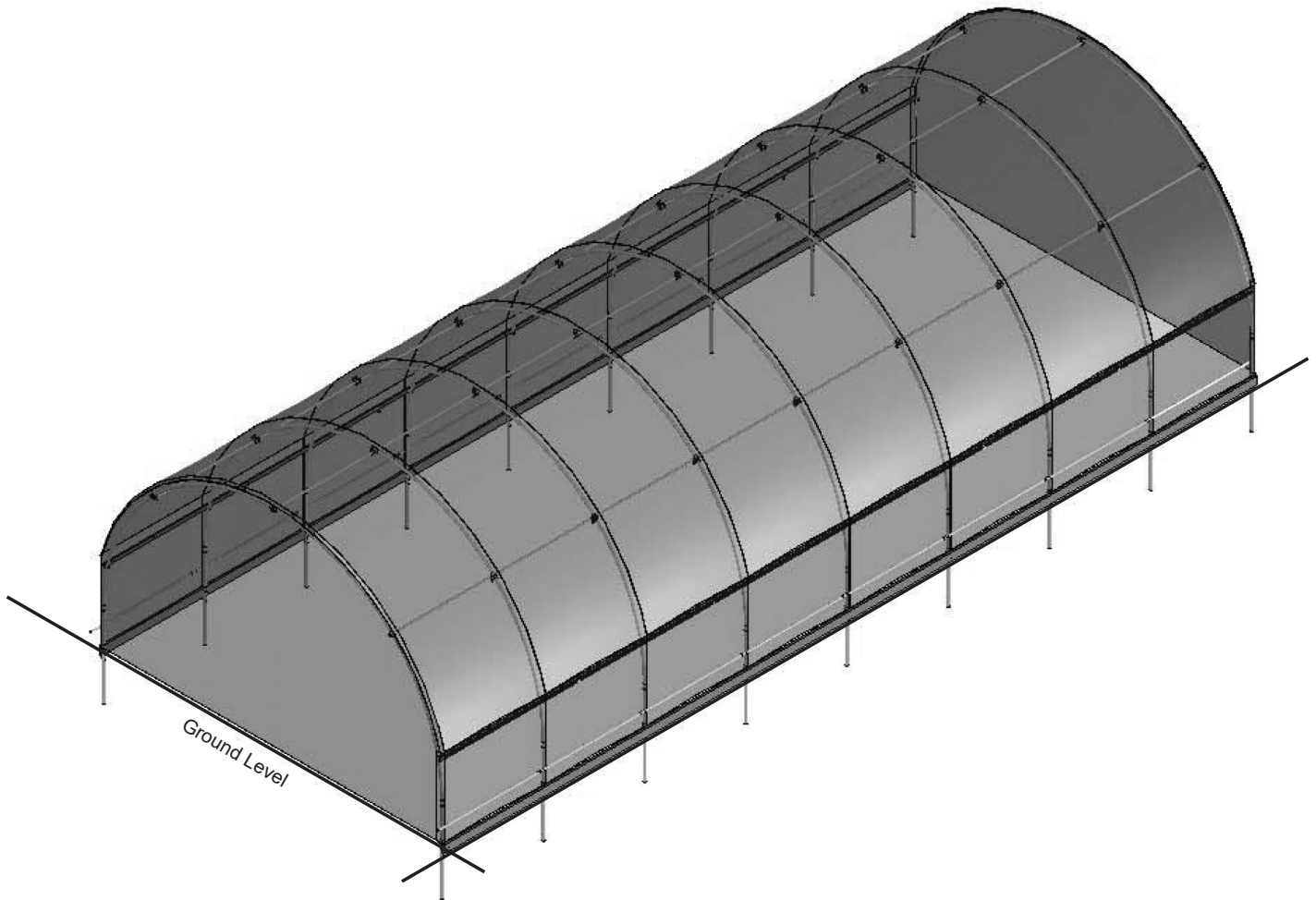
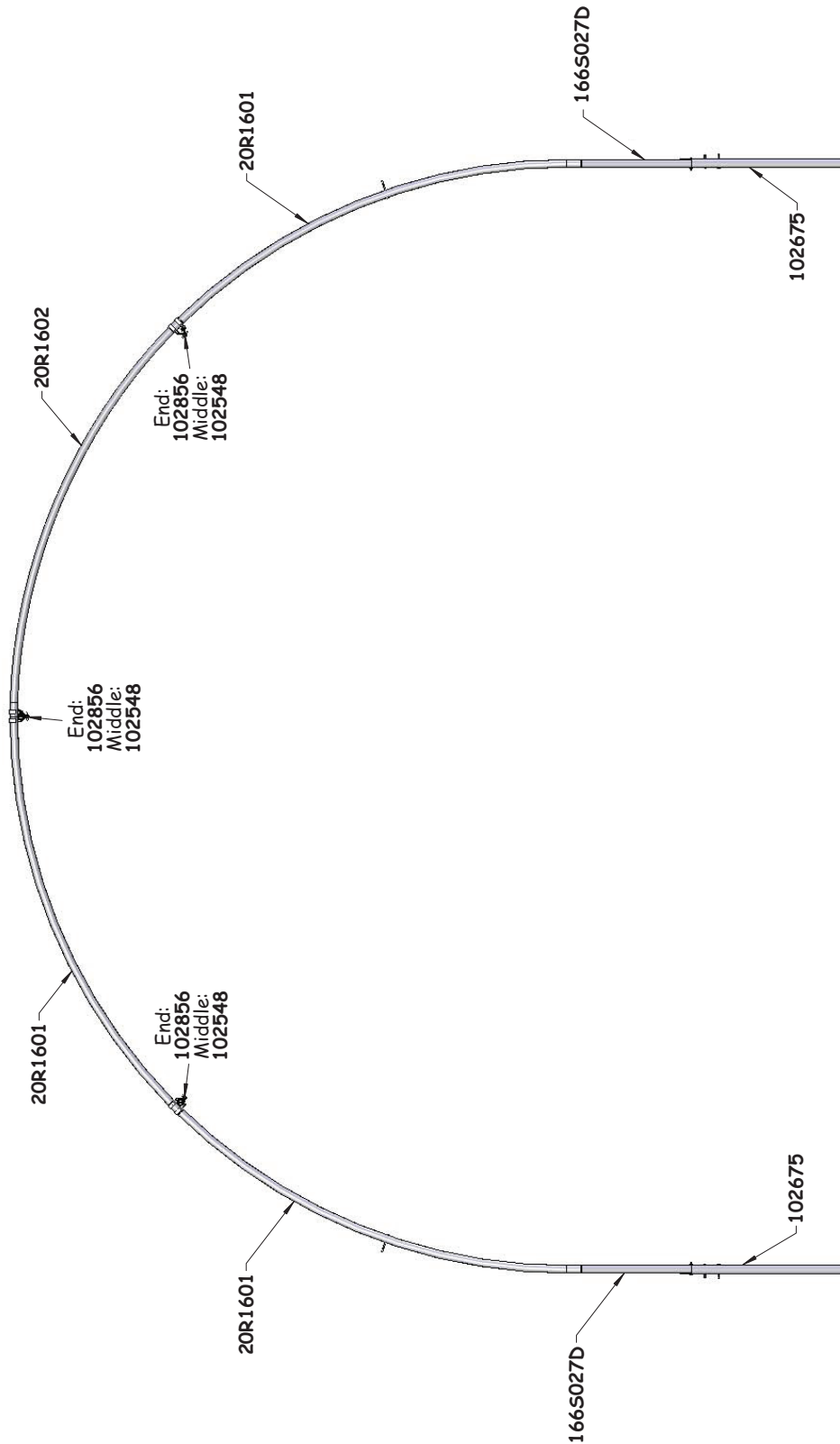
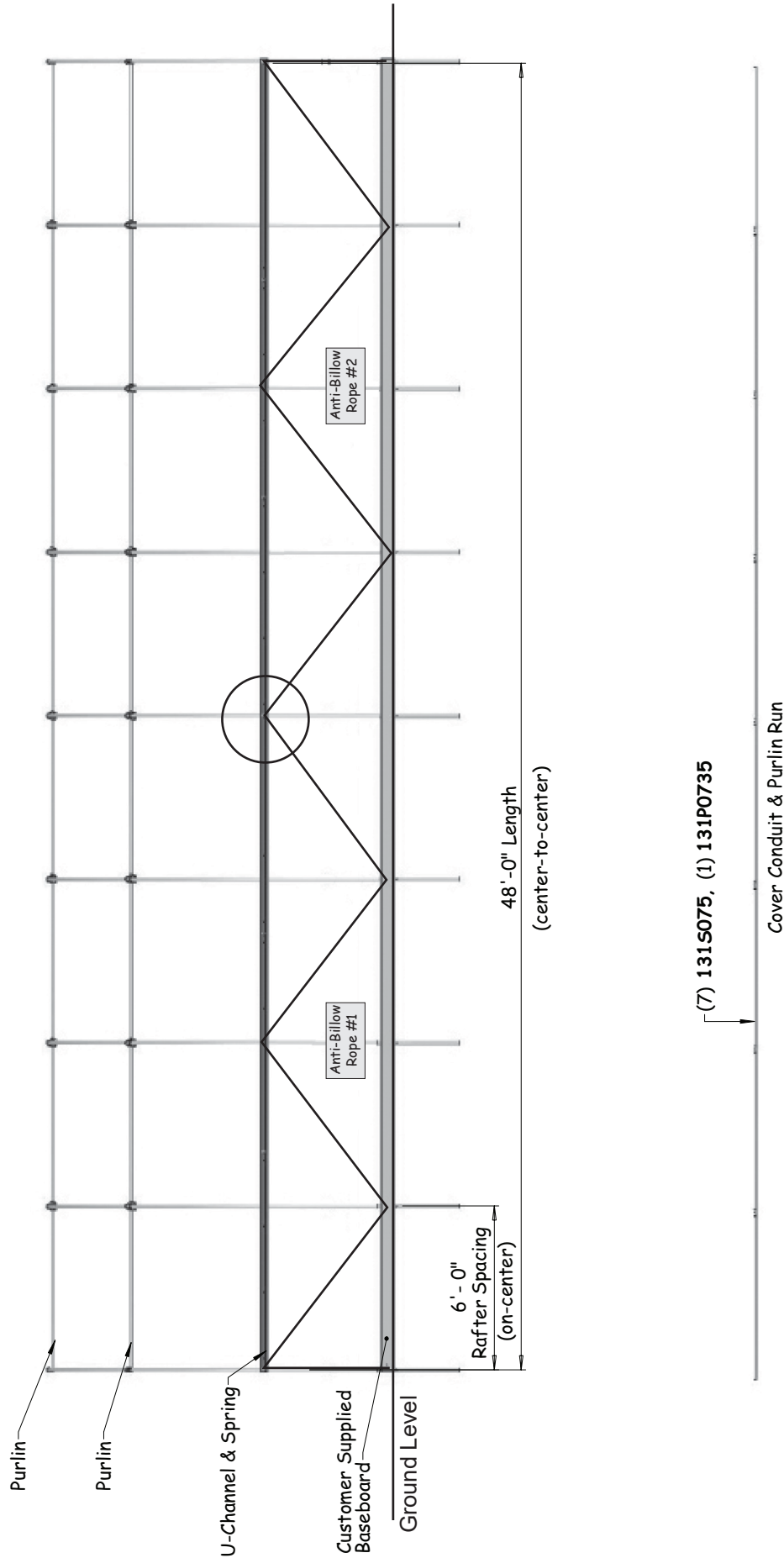

Diagram may show a different but similar model. Economy high tunnels include film roof and film end panels.

FRONT PROFILE



SIDE PROFILE - PB01680R6



ATTENTION: TO PREVENT DAMAGE AND POSSIBLE INJURY, INSTALL THE ANTI-BILLOW ROPE IN SHORT LENGTHS ALONG EACH SIDE OF THE FRAME. DO NOT INSTALL AS A SINGLE LENGTH TIED AT EACH END. DOING SO WILL RESULT IN A LOOSE SIDE PANEL SHOULD THE ROPE BREAK DURING STRONG WINDS.

ANTI-BILLOW ROPES PER SIDE
 This frame length requires two (2) anti-billow ropes and six (6) 117063 EZ-Snap Rope Clips and six (6) FA2061 eyebolts **per side**. Circled point shows the end of each rope and the location of two (2) 117063 EZ-Snap Rope Clips.

SIDE PROFILE - PB01690R6

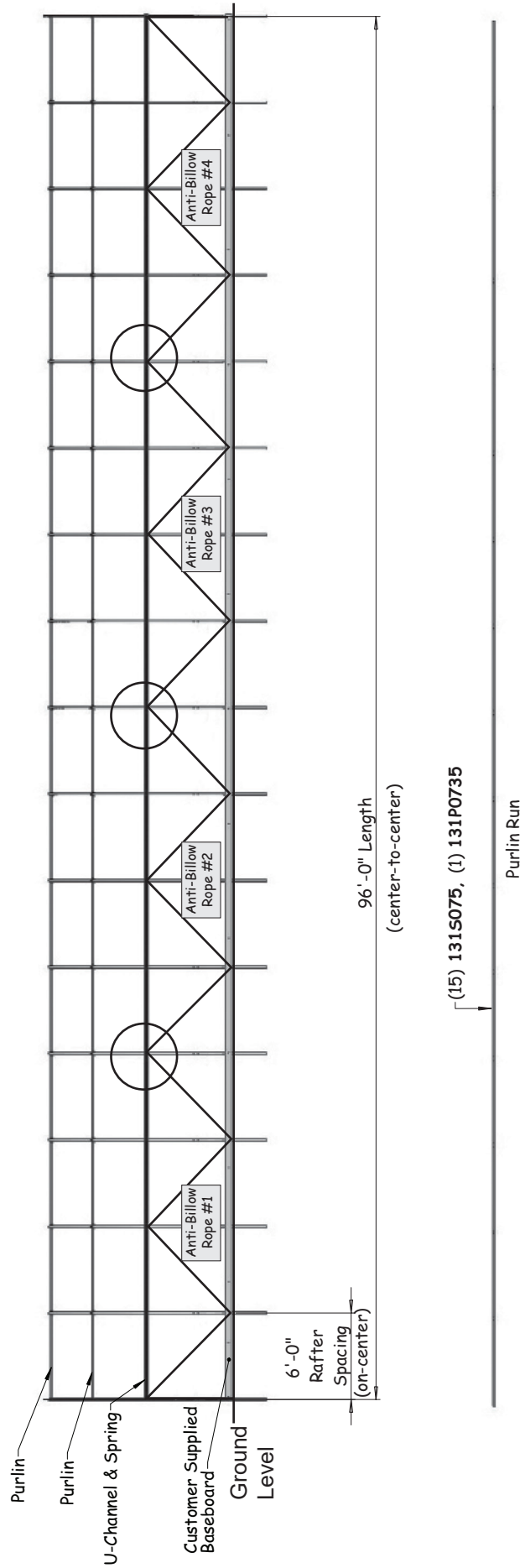

ATTENTION: TO PREVENT DAMAGE AND POSSIBLE INJURY, INSTALL THE ANTI-BILLOW ROPE IN SHORT LENGTHS ALONG EACH SIDE OF THE FRAME. DO NOT INSTALL AS A SINGLE LENGTH TIED AT EACH END. DOING SO WILL RESULT IN A LOOSE SIDE PANEL SHOULD THE ROPE BREAK DURING STRONG WINDS.

ANTI-BILLOW ROPES PER SIDE
 This frame length requires four (4) anti-billow ropes and twelve (12) 117063 EZ-Snap Rope Clips and ten (10) FA2061 eyebolts **per side**. Circled point shows the end of each rope and the location of two (2) 117063 EZ-Snap Rope Clips.

CONNECTIONS AND DETAILS

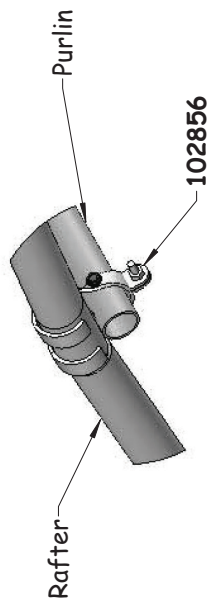
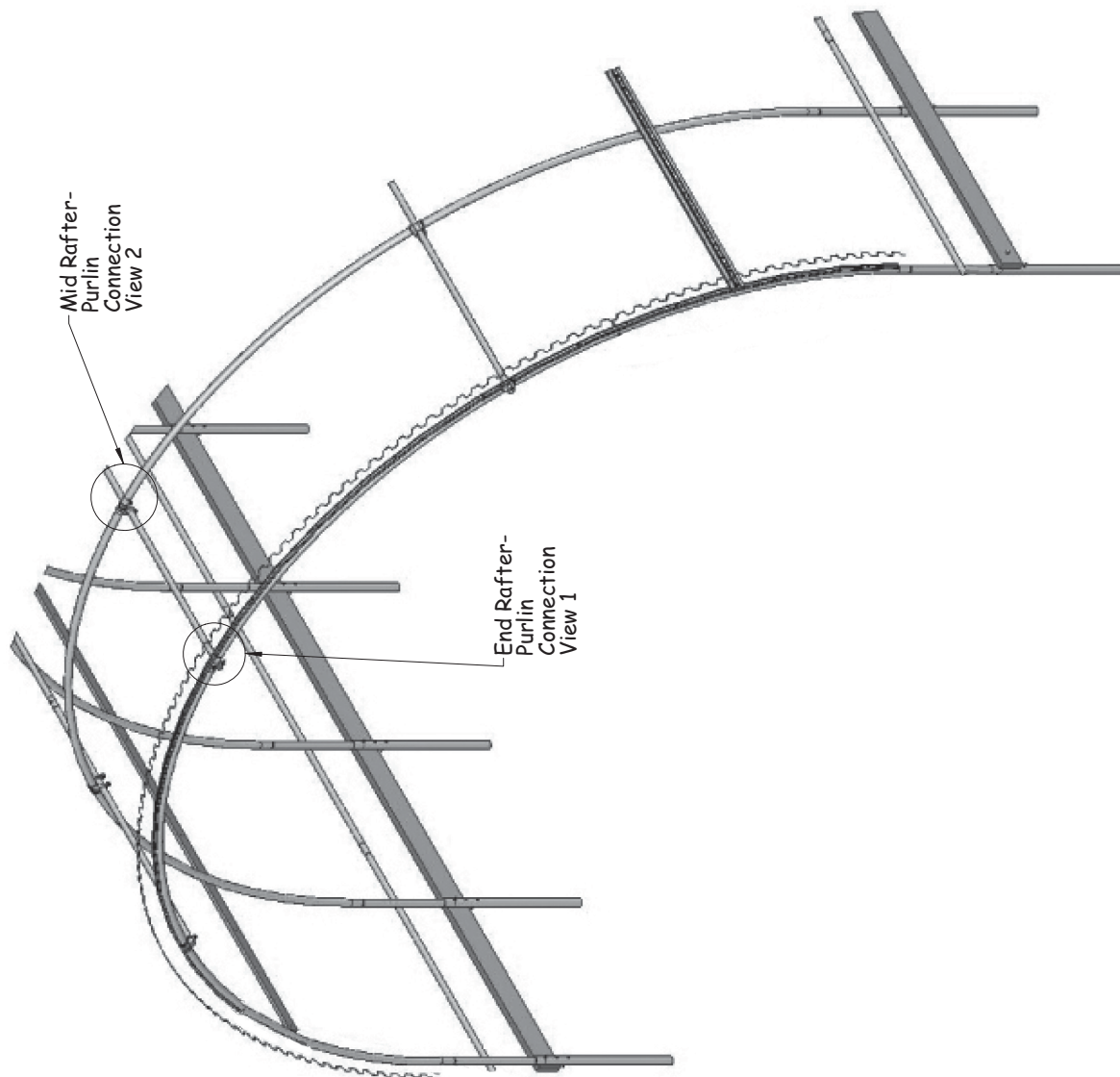

View 1
End Rafter- Purlin
Connection

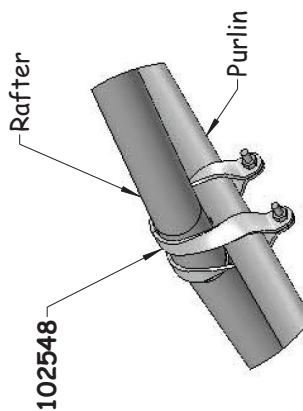

View 2
Mid Rafter- Purlin
Connection



Space below is reserved for customer notes.