

Guardmaster Safety Relays

Catalog Numbers 440R-S13R2, 440R-S12R2, 440R-D22R2, 440R-D22S2, 440R-EM4R2, 440R-EM4R2D



Important User Information

Read this document and the documents listed in the additional resources section about installation, configuration, and operation of this equipment before you install, configure, operate, or maintain this product. Users are required to familiarize themselves with installation and wiring instructions in addition to requirements of all applicable codes, laws, and standards.

Activities including installation, adjustments, putting into service, use, assembly, disassembly, and maintenance are required to be carried out by suitably trained personnel in accordance with applicable code of practice.

If this equipment is used in a manner not specified by the manufacturer, the protection provided by the equipment may be impaired.

In no event will Rockwell Automation, Inc. be responsible or liable for indirect or consequential damages resulting from the use or application of this equipment.

The examples and diagrams in this manual are included solely for illustrative purposes. Because of the many variables and requirements associated with any particular installation, Rockwell Automation, Inc. cannot assume responsibility or liability for actual use based on the examples and diagrams.

No patent liability is assumed by Rockwell Automation, Inc. with respect to use of information, circuits, equipment, or software described in this manual.

Reproduction of the contents of this manual, in whole or in part, without written permission of Rockwell Automation, Inc., is prohibited

Throughout this manual, when necessary, we use notes to make you aware of safety considerations.



WARNING: Identifies information about practices or circumstances that can cause an explosion in a hazardous environment, which may lead to personal injury or death, property damage, or economic loss.



ATTENTION: Identifies information about practices or circumstances that can lead to personal injury or death, property damage, or economic loss. Attentions help you identify a hazard, avoid a hazard, and recognize the consequence.

IMPORTANT

Identifies information that is critical for successful application and understanding of the product.

Labels may also be on or inside the equipment to provide specific precautions.



SHOCK HAZARD: Labels may be on or inside the equipment, for example, a drive or motor, to alert people that dangerous voltage may be present.



BURN HAZARD: Labels may be on or inside the equipment, for example, a drive or motor, to alert people that surfaces may reach dangerous temperatures.



ARC FLASH HAZARD: Labels may be on or inside the equipment, for example, a motor control center, to alert people to potential Arc Flash. Arc Flash will cause severe injury or death. Wear proper Personal Protective Equipment (PPE). Follow ALL Regulatory requirements for safe work practices and for Personal Protective Equipment (PPE).

| | | |
|--------------------------------|---|----|
| | Preface | |
| | Summary of Changes | 7 |
| | Who Should Use This Manual? | 7 |
| | Additional Resources | 7 |
| | Definitions | 8 |
| | Chapter 1 | |
| Overview | Hardware Features | 9 |
| | Removable Terminal Blocks | 9 |
| | Status Indicators | 9 |
| | Multi-position Switches | 10 |
| | Optical Communication Bus | 10 |
| | CI Safety Relay (Cat. No. 440R-S13R2) | 10 |
| | DI Safety Relay (Cat. No. 440R-D22R2) | 10 |
| | DIS Safety Relay (Cat. No. 440R-D22S2) | 10 |
| | EM Safety Relay (Cat. No. 440R-EM4R2) | 11 |
| | EMD Safety Relay (Cat. No. 440R-EM4R2D) | 11 |
| | SI Safety Relay (Cat. No. 440R-S12R2) | 11 |
| | Chapter 2 | |
| Installation | Mounting Dimensions | 13 |
| | DIN Rail Mounting and Removal | 13 |
| | Removal | 13 |
| | Spacing | 14 |
| | Removable Terminals | 14 |
| | Enclosure Considerations | 14 |
| | Prevent Excessive Heat | 15 |
| | Chapter 3 | |
| Power, Ground, and Wire | Wiring Requirements and Recommendation | 17 |
| | Wire Size | 17 |
| | Terminal Torque | 17 |
| | Terminal Assignments | 18 |
| | Ground the Relay | 19 |
| | Connect a Power Supply | 19 |
| | Safety Inputs | 20 |
| | Devices with Mechanical Contacts | 20 |
| | Safety Devices with OSSD Outputs | 21 |
| | Safety Mats | 23 |
| | Safety Outputs | 24 |
| | Electromechanical Outputs | 24 |
| | OSSD Outputs | 24 |
| | Surge Suppressors | 25 |
| | Single Wire Safety Input and Output | 26 |
| | Auxiliary Output | 27 |
| | Reset and Monitor Input | 27 |
| | Automatic/Manual Reset | 27 |
| | Monitored Reset | 28 |
| | Monitor with Expansion Relays | 29 |
| | Retriggerable Input | 29 |
| | Jog Input | 29 |

| | | |
|--|---|----|
| | Chapter 4 | |
| Configuration | Switch Adjustment | 32 |
| | DI and DIS Safety Relays | 32 |
| | EMD Safety Relay | 33 |
| | Configuration Process | 34 |
| | 1. Prepare the Switch | 34 |
| | 2. Apply Power | 34 |
| | 3. Adjust the Switch | 34 |
| | 4. Verify the Settings | 35 |
| | 5. Cycle the Power | 35 |
| | Chapter 5 | |
| Status Indicators and Troubleshooting | Indicators During Powerup | 37 |
| | Indicators During Normal Operation | 37 |
| | Indicators During Diagnostics | 38 |
| | Chapter 6 | |
| Pulse Testing Functions | Pulse Testing for Inputs | 39 |
| | CI Safety Relay | 39 |
| | DI, DIS, and SI Safety Relays | 40 |
| | Pulse Testing for OSSD Outputs | 40 |
| | Chapter 7 | |
| EMD Safety Relay Timing Functions | Off Delay, Non-retriggerable | 41 |
| | Case 1 | 41 |
| | Case 2 | 42 |
| | Case 3 | 42 |
| | Off Delay, Retriggerable | 42 |
| | Case 1 | 42 |
| | Case 2 | 43 |
| | On Delay | 43 |
| | Case 1 | 43 |
| | Case 2 | 43 |
| | Jog | 44 |
| | Case 1 | 44 |
| | Case 2 | 44 |
| | Case 3 | 45 |
| | Chapter 8 | |
| Internal Circuit Block Diagrams | CI Safety Relay (Cat. No. 440R-S13R2) | 47 |
| | DI Safety Relay (Cat. No. 440R-D22R2) | 47 |
| | DIS Safety Relay (Cat. No. 440R-D22S2) | 47 |
| | EM Safety Relay (Cat. No. 440R-EM4R2) | 48 |
| | EMD Safety Relay (Cat. No. 440R-EM4R2D) | 48 |
| | SI Safety Relay (Cat. No. 440R-S12R2) | 48 |

| | | |
|--|--|-----------|
| | Chapter 9 | |
| Application and Wiring Examples | CI Safety Relay (Cat. No. 440R-S13R2)..... | 49 |
| | DI Safety Relay (Cat. No. 440R-D22R2)..... | 50 |
| | DIS Safety Relay (Cat. No. 440R-D22S2)..... | 51 |
| | EM Safety Relay (Cat. No. 440R-EM4R2)..... | 52 |
| | EMD Safety Relay (Cat. No. 440R-EM4R2D)..... | 53 |
| | SI Safety Relay (Cat. No. 440R-S12R2)..... | 54 |
| | Chapter 10 | |
| Ethernet Communication | Web Page..... | 56 |
| | Studio 5000 Logix Designer Add-on Profile (AOP)..... | 56 |
| | Appendix A | |
| Specifications | General..... | 57 |
| | Environmental..... | 57 |
| | Safety Inputs IN, IN1, and IN2..... | 58 |
| | Reset Input..... | 58 |
| | B1 Input..... | 59 |
| | Safety Outputs..... | 59 |
| | Auxiliary Output..... | 60 |
| | Single Wire Safety..... | 60 |
| | Appendix B | |
| Regulatory Approvals | Agency Certifications..... | 61 |
| | Compliance to European Union Directives..... | 61 |
| | EMC Directive..... | 61 |
| | Machine Safety Directive..... | 61 |
| | SIL Rating..... | 62 |
| | Performance Level/Category..... | 62 |
| | Index | 63 |

Notes:

This manual is a reference guide for the family of Guardmaster® Safety Relays (GSR). It describes the procedures that you use to install, wire, and troubleshoot your relay. This manual also gives an overview of the operation of safety relays.

Summary of Changes

This manual contains new and updated information. We added an introductory paragraph to the [Configuration](#) chapter on [page 31](#).

Who Should Use This Manual?

Use this manual if your responsibilities include design, installation, programming, or troubleshooting of control systems that use safety relays, including catalog numbers:

- 440R-S13R2 (CI)
- 440R-D22R2 (DI)
- 440R-D22S2 (DIS)
- 440R-EM4R2 (EM)
- 440R-EM4R2D (EMD)
- 440R-S12R2 (SI)

You must have a basic understanding of electrical circuitry and familiarity with safety-related control systems. If you do not have this knowledge, obtain the proper training before using this product.

Additional Resources

These documents contain additional information concerning related products from Rockwell Automation.

| Resource | Description |
|---|---|
| Guardmaster EtherNet/IP Network Interface User Manual, publication 440R-UM009 | Describes procedures that you use to install, wire, configure, troubleshoot, and use EtherNet/IP modules. |
| Industrial Automation Wiring and Grounding Guidelines, publication 1770-4.1 | Provides general guidelines for installing a Rockwell Automation® industrial system. |
| Product Certifications website, http://www.rockwellautomation.com/global/certification/overview.page | Provides declarations of conformity, certificates, and other certification details. |

You can view or download publications at <http://www.rockwellautomation.com/global/literature-library/overview.page>. To order paper copies of technical documentation, contact your local Allen-Bradley distributor or Rockwell Automation sales representative.

Definitions

Publication [AG-7.1](#) contains a glossary of terms and abbreviations that are used by Rockwell Automation to describe industrial automation systems. The following is a list of specific terms and abbreviations that are used in this manual.

- **N.C. (Normally Closed)** - An electrical contact whose normal state is in the closed position.
- **N.O. (Normally Open)** - An electrical contact whose normal state is in the open position.
- **PLC** - A programmable logic controller or a programmable automation controller.
- **Reaction Time** - The time between the true states of one input to the ON state of the output.
- **Recovery Time** - The time that is required for the input to be in the LO state before returning to the HI state.
- **Reset** - Safety relays offer two types of reset: monitored manual and automatic/manual.
 - **Monitored Manual** - The safety relay performs a reset function when the reset signal goes from OFF to ON and then back to OFF in a prescribed time-period. The reset occurs on the trailing edge.
 - **Automatic/Manual** - The safety relay performs a reset function if the reset input is ON. If the reset input is connected directly to 24V, the reset function is executed immediately when the inputs become closed or active. If a contact (push button or equivalent device) is used in the reset input, the reset function is executed on the leading edge of the reset signal (if the inputs are closed or active).
- **Response Time** - Describes the time between the trigger of one input to the OFF state of the output. Throughout this manual, the safety outputs are described as turning off immediately, which means that the safety outputs turn off within the response time.
- **OSSD (Output Signal Switching Device)** - Typically a pair of solid-state signals that are pulled up to the DC source supply. The signals are tested for short circuits to the DC power supply, short circuits to the DC common and shorts circuits between the two signals.
- **Single Wire Safety (SWS)** - A unique, safety-rated signal that is sent over one wire to indicate a safety status. The SWS can be used in safety systems that require Category 4, Performance Level e, per ISO 13849-1 and safety integrity level (SIL) 3, per IEC 62061 and IEC 61508. When an SWS signal is present, this publication describes this state as ACTIVE or ON. This signal is also referred to as the logic link signal.

Overview

The Guardmaster safety relay (GSR) family is a group of advanced general-purpose and special-purpose safety relays. This user manual addresses the CI, DI, DIS, EM, EMD, and SI safety relays from this family of relays.

Hardware Features

Figure 1 - Safety Relays

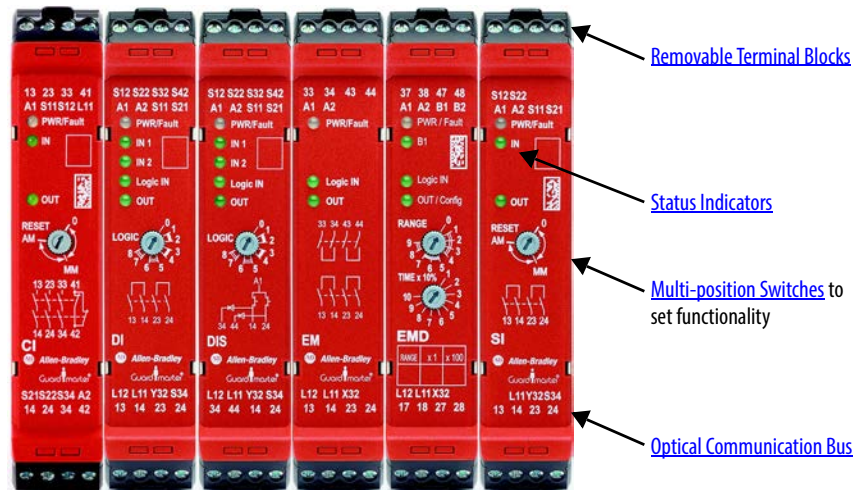

Removable Terminal Blocks

Each relay module is only 22.5 mm (0.9 in.) wide with four removable terminal blocks (two on top and two on bottom). The terminal blocks are keyed to confirm that they are installed in their proper slots.

Status Indicators

Multiple status indicators provide status and diagnostics. Under fault conditions, the PWR/Fault status indicator blinks in specific patterns to help diagnose the fault.

Multi-position Switches

Most safety relays are configured by adjusting multi-position switches to set their functionality ⁽¹⁾. The switches are on the front face of the relay so you can see the set position during, and after, configuration. During the configuration process, status indicators on the front face of the relay confirm the switch settings.

Optical Communication Bus

The DI, DIS, EM, EMD, and SI safety relays have an optical communications bus that delivers status and diagnostics to the catalog number 440R-ENETR EtherNet/IP module (not shown in [Figure 1](#)) without additional wiring. For additional information, see [Ethernet Communication on page 55](#).

Safety relays use single wire safety (SWS) signals that allow multiple safety relays to work in coordination with one another in small to medium size safety systems. The SWS feature allows safety relays to communicate the highest safety-rated control signal from one safety system to another over one wire (plus a common ground connection). The wire must be less than 30 m (98.4 ft) long.

CI Safety Relay (Cat. No. 440R-S13R2)

The CI safety relay has one dual-channel input with three electromechanical relay outputs. The CI safety relay can be configured for automatic or monitored manual reset by adjusting the switch on the front. The CI safety relay has an SWS output, but does not support SWS input.

The CI safety relay is compatible to the MSR127 safety monitoring relay. The CI safety relay has the same number of inputs and outputs, the same width, and the same terminal locations as the MSR127 relay.

DI Safety Relay (Cat. No. 440R-D22R2)

The DI safety relay has two dual-channel inputs and two electromechanical relay outputs. In addition, the DI safety relay has an SWS input and output. The DI safety relay can be set for automatic or monitored manual reset by adjusting the switch on the front panel. The configuration switch also sets the AND/OR logic that is applied to the inputs.

DIS Safety Relay (Cat. No. 440R-D22S2)

The DIS safety relay has two dual-channel inputs and four solid-state outputs. Two of the four solid-state outputs are designed to operate with high-capacitance loads. In addition, the DIS safety relay has an SWS input and output. The DIS safety relay can be set for automatic or monitored manual reset by adjusting the switch on the front panel. The configuration switch also sets the AND/OR logic that is applied to the inputs.

(1) The EM safety relay does not require configuration.

EM Safety Relay (Cat. No. 440R-EM4R2)

The EM safety relay is an expansion module with four immediately operated electromechanical relay outputs. The only input to the EM safety relay is an SWS input. The EM safety relay is designed to expand the outputs of the GSR family of host relays. The EM safety relay also has an SWS output for further expansion.

EMD Safety Relay (Cat. No. 440R-EM4R2D)

The EMD safety relay is an expansion module with delayed electromechanical relay outputs. The EMD safety relay can be configured for one of the following functions:

- On delay
- Off delay
- Jog

The settings of the two switches on the front face of the relay configure the functionality and duration of the delay and jog.

The main input to the EMD safety relay is the single wire safety input. With the SWS signal, the EMD safety relay is designed to expand the outputs of the GSR family of host relays. The EMD safety relay also has an SWS output for further expansion.

An additional input is used with the jog function or to set the off delay as retriggerable. See [EMD Safety Relay Timing Functions on page 41](#) for detailed descriptions on the EMD safety relay timing functions.

SI Safety Relay (Cat. No. 440R-S12R2)

The SI safety relay has one dual-channel input with two electromechanical relay outputs. The SI safety relay can be configured for automatic or monitored manual reset by adjusting the switch on the front. The SI safety relay also has an SWS output.

The SI safety relay is similar in functionality to the MSR126 safety monitoring relay.

Notes:

Installation

All safety relays in this manual have the same dimensions ([Figure 2](#)).

Mounting Dimensions

Figure 2 - Dimensions [mm (in.)]

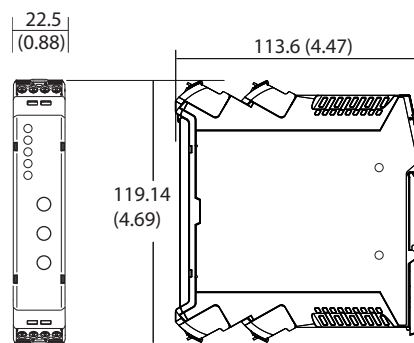

DIN Rail Mounting and Removal

Safety relays mount onto 35 mm DIN rails: 35x7.5x1 mm (EN 50022-35x7.5).

1. Hold the top at an angle ([Figure 3](#)).
2. Slide down until the housing catches the rail.
3. Swing the bottom down and push until the latch clips onto the rail.

Figure 3 - DIN Rail Mounting

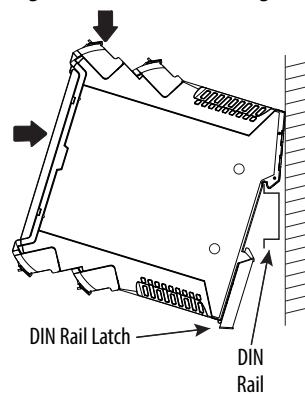

Removal

To remove a safety relay, use a screwdriver to pry the DIN rail latch downwards until it is in the unlatched position. Then, swing the module up.

Spacing

Safety relays can be mounted directly next to other safety relays. When the EtherNet/IP module is used, the safety relay must be mounted within 10 mm (0.4 in.) of its neighboring module to maintain effective communication.

Maintain a space of 50.8 mm (2 in.) above, below, and in front of the relay for adequate ventilation.

Removable Terminals

Safety relays have removable terminals to ease wiring and replacement.

Figure 4 - Removable Terminals

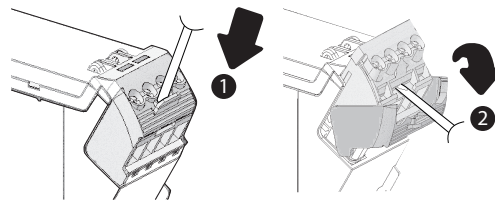

1. Insert the tip of a small screwdriver into the slot near the terminal screws.
2. To unlock the terminal block, rotate the screwdriver.

The terminal block can then be removed from the housing.

Enclosure Considerations

Most applications require installation in an industrial enclosure to reduce the effects of electrical interference and environmental exposure. Pollution Degree 2 is an environment where normally only non-conductive pollution occurs except that occasionally temporary conductivity that is caused by condensation shall be expected. Overvoltage Category II is the load level section of the electrical distribution system. At this level, transient voltages are controlled and do not exceed the impulse voltage capability of the product insulation.

This equipment is intended for use in a Pollution Degree 2 industrial environment, in overvoltage Category II applications (as defined in IEC 60664-1), at altitudes up to 2000 m (6562 ft) without derating. This equipment is considered Group 1, Class A industrial equipment according to IEC/CISPR 11. Without appropriate precautions, there may be difficulties with electromagnetic compatibility in residential and other environments due to conducted and radiated disturbances.

This equipment is supplied as open-type equipment. It must be mounted within an enclosure that is suitably designed for those specific environmental conditions that are present and appropriately designed to help prevent personal injury as a result of accessibility to live parts. The enclosure must have suitable flame-retardant properties to help prevent or minimize the spread of flame, in compliance with a flame spread rating of 5VA, V2, V1, V0 (or equivalent) if non-metallic. The interior of the enclosure must be accessible only by the use of a tool. Subsequent sections of this publication contain additional information regarding specific enclosure-type ratings that are required to comply with certain product safety certifications.

For more information, see:

- Industrial Automation Wiring and Grounding Guidelines, Rockwell Automation publication [1770-4.1](#), for additional installation requirements.
- NEMA Standard 250 and IEC 60529, as applicable, for explanations of the degrees of protection provided by different types of enclosure.

Prevent Excessive Heat

For most applications, normal convective cooling keeps the relay within the specified operating range. Verify that the specified temperature range is maintained. Proper spacing of components within an enclosure is usually sufficient for heat dissipation.

In some applications, other equipment inside or outside the enclosure can produce a substantial amount of heat. In this case, place blower fans inside the enclosure to help with air circulation and to reduce “hot spots” near the controller.

Additional cooling provisions are necessary when high ambient temperatures are encountered. Do not bring in unfiltered outside air. Place the controller in an enclosure to help protect it from a corrosive atmosphere. Harmful contaminants or dirt could cause improper operation or damage to components. In extreme cases, you may need to use air conditioning to help protect against heat buildup within the enclosure.

Notes:

Power, Ground, and Wire

Wiring Requirements and Recommendation



ATTENTION: Before you install and wire any device, disconnect power to the system.



ATTENTION: Calculate the maximum possible current in each power and common wire. Observe all electrical codes that dictate the maximum current allowable for each wire size. Current above the maximum rating causes wiring to overheat, which can cause damage.

- Allow for at least 50 mm (2 in.) between I/O wire ducts or terminal strips and the relay.
- Route incoming power to the relay by a path separate from the device wiring. Where paths must cross, their intersection must be perpendicular.
- Do not run signal or communications wiring and power wiring in the same conduit. Route wires with different signal characteristics by separate paths.
- Separate wiring by signal type. Bundle wiring with similar electrical characteristics together.
- Separate input wiring from output wiring.
- Label wiring to all devices in the system. Use tape, shrink-tubing, or other more dependable means to label wire. Use colored insulation as well to identify wiring by signal characteristics. For example, use blue for DC wiring and red for AC wiring.

Wire Size

Each terminal can accommodate copper wire with size from 0.2...2.5 mm² (24...14 AWG). Use copper that withstands 60...75 °C (140...167 °F).

Terminal Torque

Torque terminals to 0.4 N·m (4 lb·in).

Terminal Assignments

Safety relays have four terminals: two on the top and two on the bottom. As shown in [Figure 5](#), the X2 and X4 terminal markings apply to the rear terminals. The X1 and X3 terminals apply to the front terminals.

Figure 5 - Terminal Identification

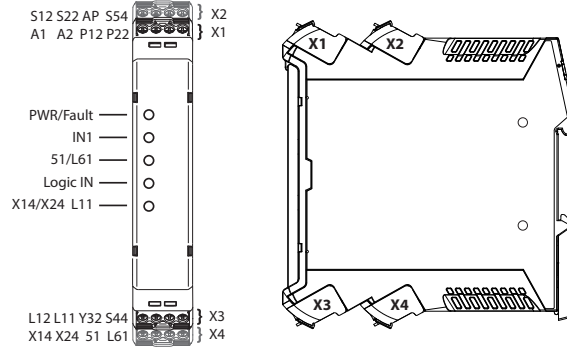

[Figure 6](#) shows the front face markings of each of the safety relays, including the terminal and status indicator identifications.

Figure 6 - Relay Face Markings

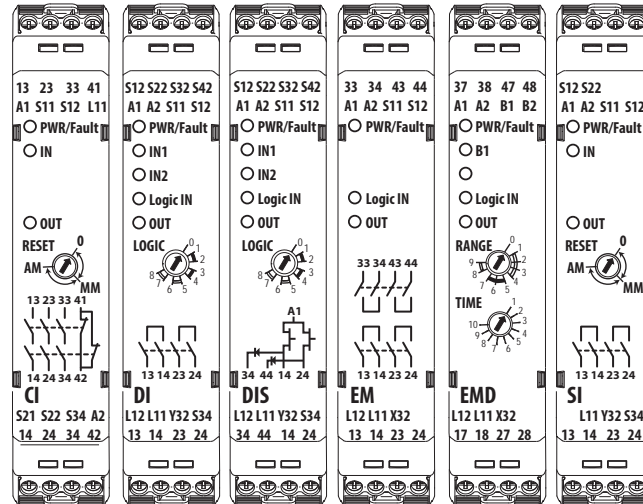

[Table 1](#) lists the terminal functions. Many of the terminals perform common functions on multiple relays.

Table 1 - Terminal Assignments and Functions

| Terminal | Function | Applies To |
|----------------------------|---|----------------------|
| A1 | +24V Supply (+10%, -15%) | All |
| A2 | 24V Common | All |
| S11 | Pulse Test Output for Channel 1 | CI, DI, DIS, and SI |
| S21 | Pulse Test Output for Channel 2 | CI, DI, DIS, and SI |
| S12 | Safety Input for IN1 Channel 1 | CI, DI, DIS, and SI |
| S22 | Safety Input for IN1 Channel 2 | CI, DI, DIS, and SI |
| S32 | Safety Input for IN2 Channel 1 | DI and DIS |
| S34 | Reset Input | CI, DI, DIS, and SI |
| S42 | Safety Input for IN2 Channel 2 | DI and DIS |
| Y32 | Auxiliary Non-safety Output | CI, DI, DIS, and SI |
| X32 | Auxiliary Non-safety Output | EM and EMD |
| B1 | Jog Input | EMD |
| B2 | Retrigger Input | EMD |
| L11 | Single Wire Safety Output | All |
| L12 | Single Wire Safety Input | DI, DIS, EM, and EMD |
| 13/14, 23/24 | Safety Outputs - electromechanical relay | CI, DI, EM, and SI |
| 33/34, 43/44 | Safety Outputs - electromechanical relay | EM |
| 14, 24 | Safety Outputs - OSSD | DIS |
| 34, 44 | Safety Outputs - OSSD for capacitive loads | DIS |
| 17/18, 27/28, 37/38, 47/48 | Safety Outputs, Delayed - electromechanical relay | EMD |

Ground the Relay

There are no special grounding requirements. Terminal A2 must be connected to the common of a 24V supply.

Connect a Power Supply

An external 24V DC power supply source must provide power for safety relays.

To comply with the CE (European) Low Voltage Directive (LVD), a DC source compliant with safety extra low voltage (SELV) or protected extra low voltage (PELV) must power the safety relays. Bulletin 1606 power supplies are SELV- and PELV-compliant.

Figure 7 shows the power supply connections. The DI, DIS, EM, EMD, and SI safety relays have the power supply connections at the top. The CI safety relay, which is backward compatible with the MSR127 monitoring safety relay, has A1 at the top and A2 at the bottom.

Figure 7 - Power Supply Connections

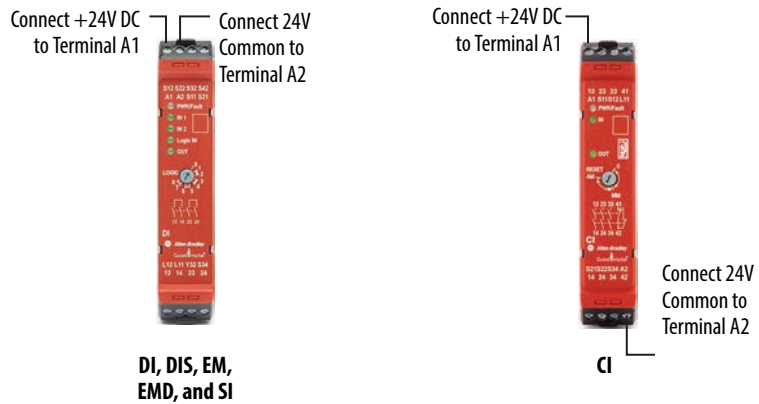

Safety Inputs

Devices with Mechanical Contacts

The GSR family of safety relays can be connected to safety devices that have mechanical contacts. The relays can accommodate either 1 N.C. or 2 N.C. circuits. Table 2 shows some of the devices that can be connected to safety relays.

Table 2 - Safety Devices with Mechanical Contacts

| Safety Device | Example Rockwell Automation Products | Contact Availability |
|---|--|---------------------------------|
| E-stop Push Buttons | 800F, 800T | 1 N.C., 2 N.C., self-monitoring |
| Tongue Operated Interlock Switches | Trojan™, MT-GD2, Cadet™, Elf™ | 1 N.C., 2 N.C. |
| Guard Locking Interlock Switches | 440G-LZ, TLS-Z, TLS-GD2, Atlas™ | 1 N.C., 2 N.C. |
| Noncontact Switches with Reed Relays | Ferrogard™, Sipha™, magnetically coded | 1 N.C., 2 N.C. |
| Hinge Operated Interlock Switches | Rotacam™, Ensign, Sprite | 1 N.C., 2 N.C. |
| Limit Switches | 440P, 802T | 1 N.C., 2 N.C. |
| Trapped Key Interlocks with Electrical Contacts | 440T | 1 N.C., 2 N.C. |
| Cable Pull Switches | Lifeline™ | 1 N.C., 2 N.C. |
| Enabling Devices | GripSwitch | 1 N.C., 2 N.C. |
| Interposing Relays | 700-HPS | 1 N.C., 2 N.C. |

[Figure 8](#) shows the typical connections for devices with 2 N.C. mechanical contacts. One side of each contact is connected to a pulse-testing outputs S11 and S21. The other side is connected to an input terminal. The CI and SI safety relays only have one set of input terminals. The DI and DIS safety relays have two sets of input terminals. The DI and DIS safety relays can operate with only one device that is connected to either input or with devices that are connected to both inputs.

Figure 8 - Example Connections to 2 N.C. Mechanical Contacts

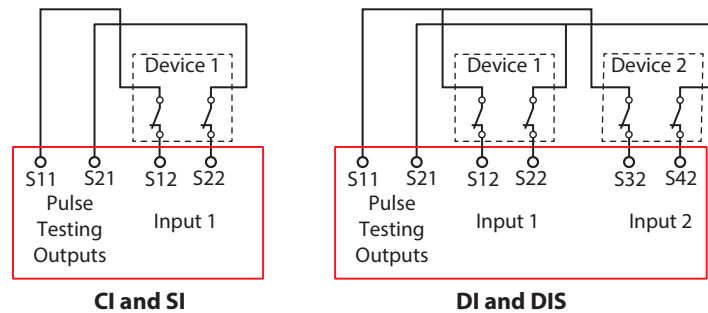

[Figure 9](#) shows the typical connections for devices with 1 N.C. mechanical contact. One side of the contact is connected to a pulse-testing output S11. The other side is connected to two input terminals. The CI and SI safety relays only have one set of input terminals. The DI and DIS safety relays have two sets of input terminals. The DI and DIS safety relays can operate with only one device that is connected or with devices that are connected to both inputs.

Figure 9 - Example Connections to 1 N.C. Mechanical Contact

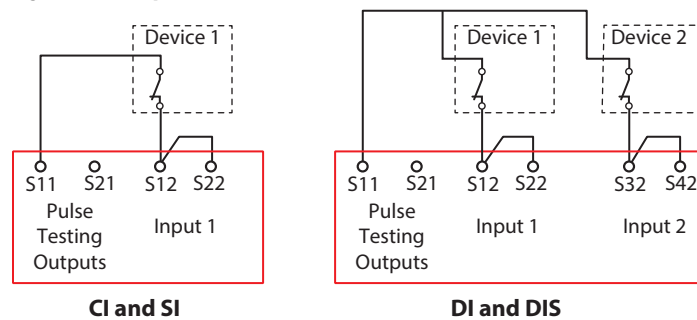

Safety Devices with OSSD Outputs

Devices, such as the GuardShield™ safety light curtains, SafeZone™ laser scanners, SensaGuard™ interlock switch, TLS-Z and 440G-LZ guard locking switches, and Bulletin 442G Multifunction Access Box (MAB) have current-sourcing PNP semiconductor outputs (OSSD), which send their own pulse-tested safety signals through their outputs. These devices do not need to be connected to the safety relay pulse-testing outputs. These devices must have a common power supply reference (24V Com).

Figure 10 shows a typical example of the connections for devices, like light curtains or laser scanners, with non-cascadable OSSD outputs.

Figure 10 - Example Connections to Devices with Non-cascadable OSSD Outputs

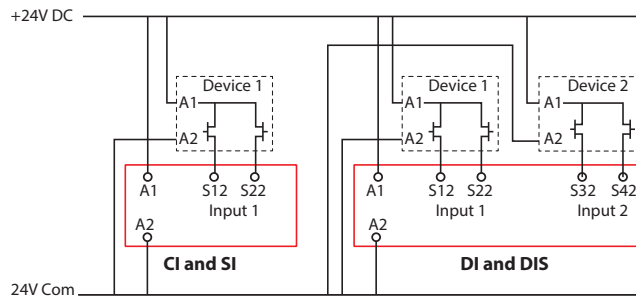

- TIP**
- OSSD1 can be connected to either S12 or S22 and OSSD2 can be connected to either S12 or S22.
 - The safeguarding devices must have the same voltage supply reference (24V Com) as the safety relay.

Figure 11 shows an example of a wiring configuration that includes non-cascadable and cascade-able devices. The non-cascadable devices (Devices 1 and 2) must always start the cascade. Many cascadable devices (Devices 3...6 or more) can be included in the input circuit. All devices must have the same voltage supply reference (for instance, 24V Com) as the safety relay.

Examples of non-cascadable devices include GuardShield light curtains, SafeZone laser scanners, and safety sensors. Examples of cascadable devices include SensaGuard interlocks, and the TLS-ZR and 440G-LZ guard locking interlocks.



ATTENTION: You must consider the cumulative response time of all cascaded devices, the relay, and output devices to verify that the safety function is fulfilled within the required time that is determined by the risk assessment.

Figure 11 - Example Connections to Device with Cascaded and Non-cascaded OSSD Devices

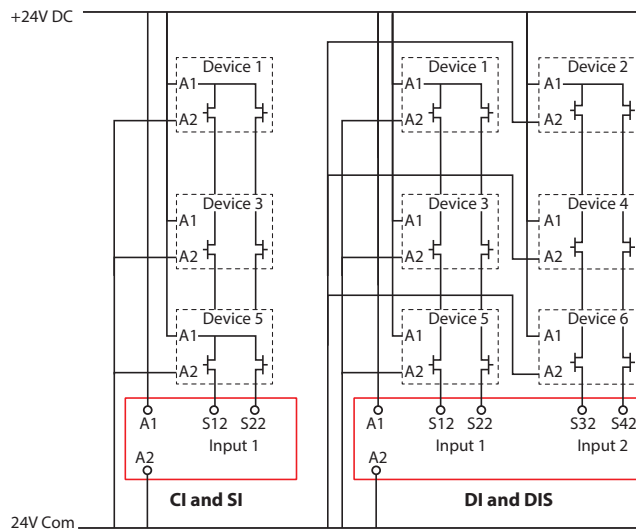

Safety Mats

Guardmaster (and similar) safety mats can be connected to safety relays. These mats use parallel metal-plate technology. Stepping on the mat shorts the top metal plate to the bottom metal plate. With the proper connections, safety relays detect the presence of an object on the mat and turn off their outputs. With no presence on the mat, safety relays turn on their outputs.

[Figure 12](#) shows the typical connections for safety mats. You notice the reverse of the wiring between a device with 2 N.C. contacts and the safety mat.

When a safety mat is used, safety relays cannot detect short circuits between the inputs or between the inputs and 24V DC. These conditions must be tested during validation.

IMPORTANT When using safety mats, the DI and DIS safety relays must be set for AND logic. If only one mat is used, the second input must be connected with jumpers or to another safety device. If another safety device is connected to the second input, the outputs of the safety device must be ON during configuration and during powerup.

Figure 12 - Example Connections to Safety Mats

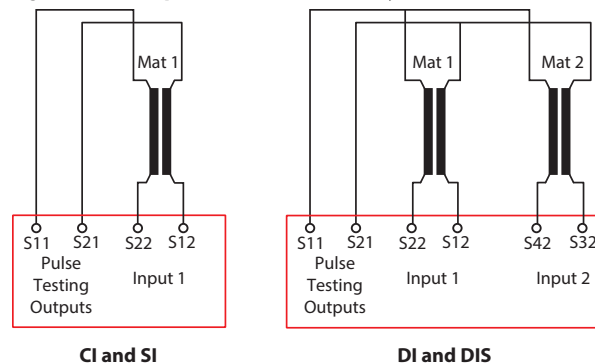

Safety Outputs

Electromechanical Outputs

Internally, the CI, DI, EM, EMD, and SI safety relays have two positive-guided relays that are connected in series to form the safety outputs. One side of the contact must be connected to a voltage supply (see [Specifications on page 57](#) for appropriate ratings). The other side of the contact must be connected to a load.

Figure 13 - Electromechanical Output Connections

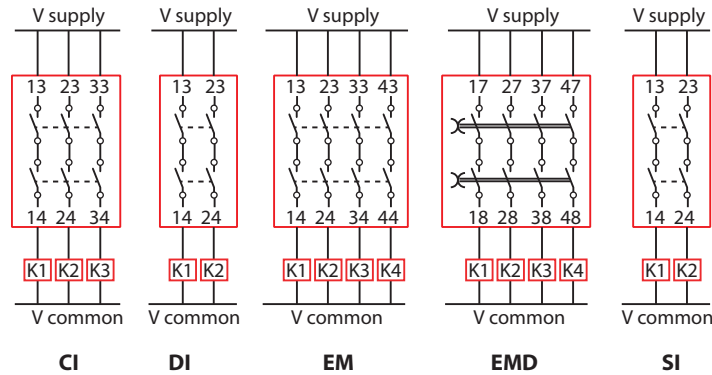

OSSD Outputs

The DIS safety relay has OSSD safety outputs on terminals 14, 24, 34 and 44. Terminals 34 and 44 have a series diode; these terminals are intended for devices with high capacitance. Output terminals 14 and 24 are pulse tested and can only tolerate a load capacitance up to 1.6 μF . Output terminals 34 and 44 are pulse tested and can tolerate a load capacitance up to 9 μF . For example, use terminals 34 and 44 when connecting to the Enable input of the PowerFlex[®] 70 drive and the Safe Torque Off inputs of the PowerFlex and Kinetix[®] drives.

The pulse-tested outputs check for short circuits:

- Between each terminal
- Between each terminal and the 24V supply
- Between each terminal and 24V common.

The load must be connected to the same voltage reference as terminal A2.

Figure 14 - OSSD Output Connections

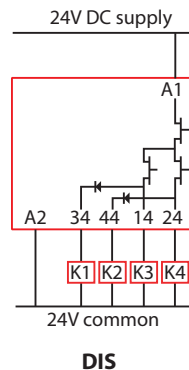

Surge Suppressors

Because of the potentially high current surges that occur when switching inductive load devices, such as motor starters and solenoids, the use of some type of surge suppression to help protect and extend the operating life of the relays is required. By adding a suppression device directly across the coil of an inductive device, you prolong the life of the outputs. You also reduce the effects of voltage transients and electrical noise from radiating into adjacent systems.

[Figure 15](#) shows an output with a suppression device. We recommend that you locate the suppression device as close as possible to the load device.

For outputs that use 24V DC, we recommend 1N4001 (50V reverse voltage) to 1N4007(1000V reverse voltage) diodes for surge suppression for the OSSD safety outputs ([Figure 15](#)). The diode must be connected as close as possible to the load coil.

For outputs that use 120V AC or 240V AC, we recommend metal oxide varistors.

Figure 15 - Surge Suppressors

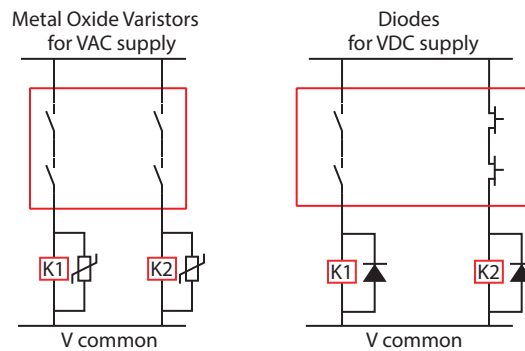

Example surge suppressors include the following catalog numbers:

- 100-FSD250 for Bulletin 100S contactors
- 1492-LD4DF terminal block with built-in 1N4007 diode
- 1492-JD3SS terminal block with built-in varistor

Single Wire Safety Input and Output

The Single Wire Safety (SWS) feature allows a safety relay to expand the safety function to additional safety relays using one wire, provided all safety relays have the same voltage supply reference.

The CI and SI safety relays only have SWS outputs (terminal L11). The DI, DIS, EM, and EMD safety relays have both SWS inputs (terminal L12) and SWS outputs (terminal L11).

There can be many variations and combinations of series and parallel connections of the SWS. Each L11 terminal can be connected to up to ten L12 terminals.

IMPORTANT Do not connect two or more L11 terminals together.

Figure 16 shows an example wiring diagram with SWS input from a DI safety relay and SWS output connection to an EM safety relay in parallel with a DIS safety relay. The safety relays must have a common power reference (24V common). In this example, the safety function started by the CI or SI safety relay is expanded to the DI safety relay. The safety functions monitored by the DI safety relay are expanded to the EM and DIS safety relays. The safety functions monitored by the DIS safety relay are expanded to the EMD safety relay.



ATTENTION: You must consider the additional response time of each SWS connection when calculating the safety distance. See [Specifications on page 57](#) for the response time for each relay.

Figure 16 - Example SWS Connections

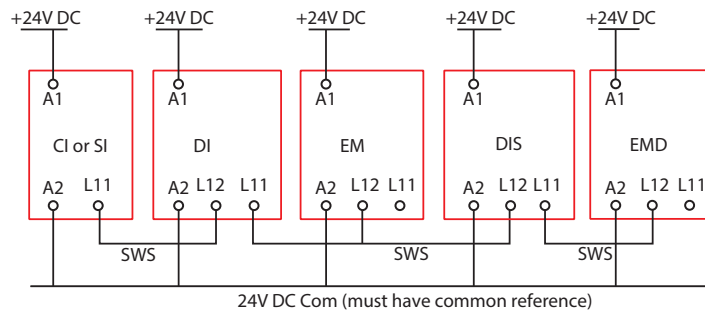
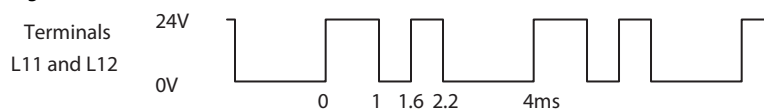

Figure 17 shows the characteristics of SWS signal when it is active. It starts with a 1 ms pulse, followed 600 μ s later by a 600 μ s pulse. This waveform is repeated every 4 ms. When inactive, the SWS is 0V.

Figure 17 - SWS Waveform



Auxiliary Output

Each safety relay has an auxiliary output. The auxiliary output is not a safety rated output; it is a low current output that is designed to indicate that the safety output status is OFF. The auxiliary output is in the opposite state of the safety outputs. When the safety outputs are ON, the auxiliary output is OFF. When the safety outputs are OFF, the auxiliary output is ON.

When the EM and EMD safety relays are in a faulted state, the auxiliary outputs are in an OFF state because the auxiliary outputs are often used as the source of the monitoring circuit. If the EM or EMD safety relays are faulted, the safety system must not reset until the fault is corrected.

The DI, DIS, EM, EMD, and SI safety relays have a solid-state transistor auxiliary output. The CI safety relay has an electromechanical output. [Table 3](#) summarizes the terminal connections of the auxiliary output.

Table 3 - Auxiliary Outputs

| Relay | Type of Output | Terminal Connections |
|-------------|-------------------|----------------------|
| CI | Electromechanical | 41/42 |
| DI, DIS, SI | Transistor | Y32 |
| EM, EMD | Transistor | X32 |

Reset and Monitor Input

The CI, DI, DIS, and SI safety relays have a reset/monitoring input (terminal S34). The expansion relays (EM and EMD) do not have a reset input.

The reset action can be configured for either automatic or monitored reset. With automatic reset, the safety relay outputs turn ON as soon as the safety inputs are closed. With monitored reset, the safety relay outputs turn ON after the inputs are closed and then the reset input is cycled from OFF to ON and then back OFF again.

Monitoring of external devices, like safety control relays and safety contactors, can be accomplished by adding normally closed contacts in series with the reset signal.

Automatic/Manual Reset

Use automatic reset when the risk assessment does not require additional manual intervention to reset the safety system. Automatic reset is often used with partial body access or where an additional control is implemented in the machine control system to start the hazardous portion of the machine after the safety inputs are closed.

When automatic reset is desired, the S34 input must be connected to 24V DC. [Figure 18 on page 28](#) shows three possibilities:

- a. A direct connection
- b. A connection through some monitoring contacts
- c. A connection through a normally open push button.

Connection through a monitoring contact and push button can be combined. When a push button is used, the reset occurs when the circuit is closed (not when it is released).

Figure 18 - Automatic/Manual Reset Connections

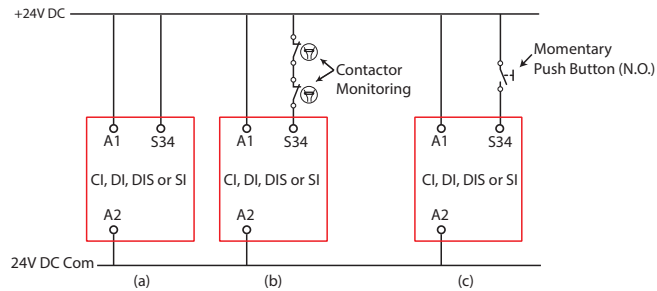

Monitored Reset

Monitored reset requires a specific signal to turn on the safety outputs. The safety inputs and single wire safety input (if used) must be closed before the reset. The reset signal must cycle from 0V to 24V and back to 0V within a duration of 250...3000 ms, as shown in Figure 19. The reset occurs on the trailing edge.

Monitored reset must be used in applications that have full-body access to the hazard. Monitored reset can also be used in applications that require partial body access.

Figure 19 - Monitored Reset Signal Duration

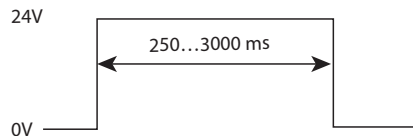

The signal can be created with a momentary push button or programmatically created with logic controller. Figure 20 shows example wiring connections for the reset. The schematic also shows an example monitoring the mechanically linked, normally closed contacts of two contactors.

TIP When using a PLC to generate the reset signal, set the duration to 260...2990 ms for a more reliable reset.

Figure 20 - Monitored Reset Connections

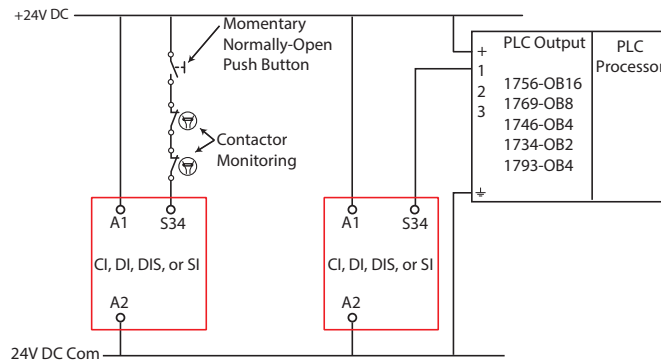

Monitor with Expansion Relays

Monitoring of the expansion relays is recommended. This feature is especially useful when the expansion relay is turning on loads (for example, solenoid-operated valves) that do not have monitoring contacts. The auxiliary output of the expansion relay must be the 24V DC source of the reset and monitoring input. [Figure 21](#) shows an example of the connections for a monitored reset with additional contactor monitoring. This type of connection can also be used for automatic reset applications.

Figure 21 - Monitor Expansion Relay

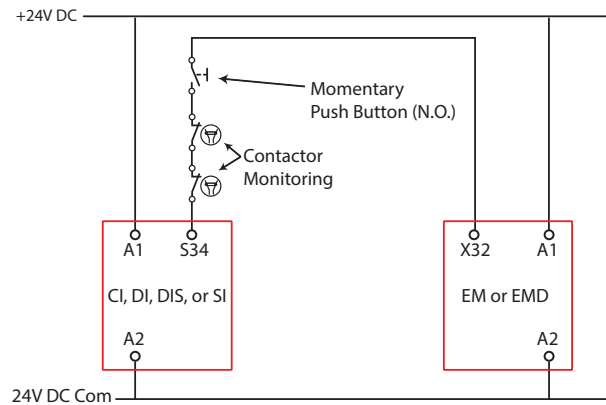

Retriggerable Input

The EMD safety relay has a retriggerable input. Retriggerable operation only works in off-delay applications. Retriggerable operation is accomplished by connecting a jumper from terminal B1 to B2. [Table 4](#) describes the off-delay operation.

Table 4 - Retriggerable Operation

| Configuration | Jumper | Action |
|-------------------|--------|--|
| Retriggerable | B1-B2 | If the safety input is triggered and cleared within the duration of the time delay, then the timing request is ignored and the safety output contacts remain closed. The B1 indicator is ON. |
| Non-retriggerable | None | The full time delay lapses and the safety output contacts open before the relay can be reset. The B1 indicator is OFF. |

Jog Input

When the EMD safety relay is configured for the Jog functions, terminal B1 must be connected to +24V DC.

Notes:

Configuration

The multi-position, rotary switches on the front face of a GSR relay determine its functionality. The configuration method of a GSR relay must provide means to help protect against manipulation and maintain integrity of the configuration.

The rotary switches accommodate a small screwdriver to turn the switch to the desired switch position. The configuration procedure implies “a willing action” by the person configuring the safety function, to prove that the person is conscious and enabled to perform this task. Therefore, the GSR relays require a procedure of turning a switch to position “0” to start the configuration mode and then turn to the position desired.

The status indicators on the front panel provide continuous feedback by flashing the switch positions. Power cycling the device in a timely manner completes the configuration mode and the device enters operation.

IMPORTANT To keep your GSR relay from permanently faulting, complete the configuration process by power cycling the relay within 5 minutes after configuring rotary switches.

We recommend that the configuration is completed within 5 minutes. The actual technical limitation of the internal EEPROM is around 8 hours. The switch positions are monitored and verified during configuration by the internal micro-controllers to achieve the required diagnostics coverage for the PLe safety rating. The EEPROM read/write cycles are limited and can cause a permanent fault of the GSR relay after several hours.

Switch Adjustment

These safety relays have multi-position switches on their front face. Use a small screwdriver to set the switches to the desired setting.

TIP Make note of the location of the mechanical stops.

Figure 22 - Configuration Switch Adjustment

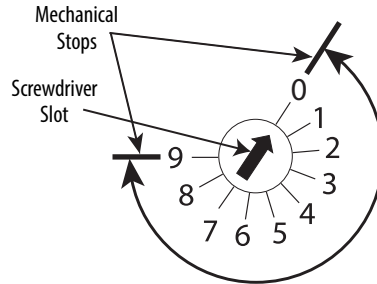

IMPORTANT Adjust the switches gently and do not turn past the mechanical stops.

CI and SI safety relays have a 3-position Reset switch. This switch determines whether the relay uses a monitored manual reset or an automatic/manual switch (see [Definitions on page 8](#)).

Table 5 - CI and SI Logic Switch

| Position | Function |
|----------|------------------------|
| 0 | Start configuration |
| MM | Monitored manual reset |
| AM | Automatic/manual reset |

DI and DIS Safety Relays

The DI and DIS safety relays have a 10-position switch and use only the first nine positions. As shown in [Table 6](#), this switch configures the relay for its reset and logic functionality.

Table 6 - DI and DIS Logic Switch

| Position | Reset | Function |
|----------|------------------|-----------------------|
| 0 | Not applicable | Start configuration |
| 1 | Monitored Manual | (IN1 OR IN2) OR L12 |
| 2 | | (IN1 AND IN2) OR L12 |
| 3 | | (IN1 OR IN2) AND L12 |
| 4 | | (IN1 AND IN2) AND L12 |
| 5 | Automatic/Manual | (IN1 OR IN2) OR L12 |
| 6 | | (IN1 AND IN2) OR L12 |
| 7 | | (IN1 OR IN2) AND L12 |
| 8 | | (IN1 AND IN2) AND L12 |

- Example 1
Logic setting 1 or 5: If any of the inputs (IN1, IN2, or L12) are ON, then the safety relay refers to the reset logic.
- Example 2
Logic setting 4 or 8: If all three of the inputs (IN1, IN2, and L12) are ON, then the safety relay refers to the reset logic.

EMD Safety Relay

The EMD safety relay has two switches. The combination of the switch settings determines the functionality and the duration. During configuration, the Time switch determines the duration of the Range switch. [Figure 23](#) shows the setting options for the Range and Time switch. [Table 7](#) shows the same information.

With the Time switch set to 1 at the start of the configuration process, the duration of the Range switch is the shorter range.

With the Time switch set to 10 at the start of the configuration process, the duration of the Range switch is the longer range.

Figure 23 - EMD Range and Time

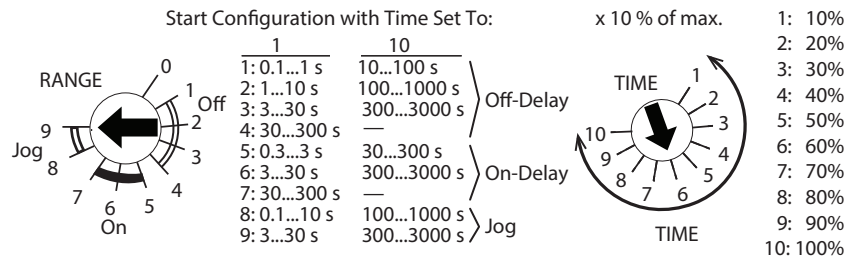

Table 7 - EMD Range and Time Settings

| Position | Function | Range (Time 1) [s] | Range (Time 10) [s] |
|----------|---------------------|--------------------|---------------------|
| 0 | Start Configuration | — | — |
| 1 | Off Delay | 0.1...1 | 10...100 |
| 2 | | 1...10 | 100...1000 |
| 3 | | 3...30 | 300...3000 |
| 4 | | 30...300 | — |
| 5 | On Delay | 0.3...3 | 30...300 |
| 6 | | 3...30 | 300...3000 |
| 7 | | 30...300 | — |
| 8 | Jogging | 0.1...10 | 100...1000 |
| 9 | | 3...30 | 300...3000 |

Configuration Process

The configuration process requires the wiring to be completed and the inputs closed. During the configuration process, safety relays send out test pulses to determine how they are wired and then configures the internal parameters to match the application.

Safety relays are configured in five steps:

1. With the power OFF, prepare the switches.
2. Apply power.
3. Adjust the switches to desired functionality.
4. Verify the settings by counting the blink rates of the status indicators.
5. Cycle the power to store the settings.

The details for each step are described in the following sections.

1. Prepare the Switch

- DI/DIS safety relay: Set the Logic switch to position 0.
- CI/SI safety relay: Set the Reset switch to position 0.
- EMD safety relay: Set the Range switch to position 0 and set Time switch to 1 (for shorter timing range) or 10 (for longer timing range).
- EM safety relay: No switches. No action necessary.

2. Apply Power

After a short wait, the PWR/Fault status indicator flashes red continuously at a 1 Hz rate (0.5 seconds ON, 0.5 seconds OFF). The prior configuration in the EEPROM is erased, and the device now prepared for a new configuration.

3. Adjust the Switch

Adjust the Logic, Reset, Time, and Range switch settings for your application.

TIP You can change the switch settings during Step 3 and 4. The power status indicator momentarily flashes red again.

4. Verify the Settings

Table 8 shows the status indicator that flashes to show the switch setting for each relay.

Table 8 - Configuration Confirmation

| Relay | Status Indicator | Switch Setting |
|-------|------------------|----------------|
| CI | IN | Reset |
| DI | IN 1 | Logic |
| DIS | IN 1 | Logic |
| EMD | B1 | Range |
| | Logic IN | Time |
| SI | IN | Reset |

Figure 24 shows an example of the blinking patterns for the EMD relay. The status indicators flash for 0.5 seconds to indicate the switch settings. The number of flashes is equal to the switch setting. The blinking pattern repeats after a 2-second pause.

Figure 24 - Example of the EMD Indicators Flashing during Configuration Mode

B1 - Indicates that the RANGE Switch is set to 3.



Logic IN - Indicates that the TIME Switch is set to 4.



5. Cycle the Power

After power-up, the current switch settings are compared to the values in the EEPROM (to make sure that the switches were not changed while power was off), and the input and output circuits are checked. Upon successful completion of the internal checks, the relays are ready for operation.

Notes:

Status Indicators and Troubleshooting

Indicators During Powerup

The status indicators provide operating status and diagnostic information.

Indicators During Normal Operation

Table 9 - Status Indicators (Normal Operation)

| Status Indicator | Models | State | Description |
|------------------|------------------|-------------------------|---|
| PWR/Fault | All | Solid Green | Normal operation. |
| | | Blinking Red | Non-recoverable fault. See Table 10 on page 38 . Correct fault and cycle power |
| | | Green with Blinking Red | Recoverable fault. See Table 10 on page 38 . Correct fault and press Reset. |
| | | Solid Red | Internal Fault. Cycle power. |
| IN or IN 1 | CI, DI, DIS, SI | ON | Input circuits at S12 and S22 are closed. |
| | | OFF | Input circuits at S12 and S22 are open. |
| IN 2 | DI, DIS | ON | Input circuits at S32 and S42 are open. |
| | | OFF | Input circuits at S32 and S42 are open. |
| B1 | EMD | ON | Input circuit at B1 is closed. |
| | | OFF | Input circuit at B1 is open. |
| LOGIC IN | DI, DIS, EM, EMD | ON | Logic IN signal (Single Wire Safety) at L12 is ON. |
| | | OFF | Logic IN signal at L12 is OFF. |
| | EMD | Flashing | Timing cycle is in process. |
| OUT | All | ON | L11 is ON. |
| | | OFF | L11 is OFF. |
| | CI | ON | 13/14, 23/24, 33/34 closed (41/42 open). |
| | | OFF | 13/14, 23/24, 33/34 open (41/42 closed). |
| | | Flashing | Safety input is closed, waiting for the reset input. |
| | DI | ON | 13/14, 23/24 closed (Y32 OFF). |
| | | OFF | 13/14, 23/24 open (Y32 ON). |
| | | Flashing | Safety inputs are closed, waiting for the reset input. |
| | DIS | ON | 14, 24, 34, 44 ON (Y32 OFF). |
| | | OFF | 14, 24, 34, 44 OF (Y32 ON). |
| | | Flashing | Safety inputs are closed, waiting for the reset input. |
| | EM | ON | 13/14, 23/24, 33/34, 43/44 closed (X32 OFF). |
| | | OFF | 13/14, 23/24, 33/34, 43/44 open (X32 ON). |
| | EMD | ON | 17/18, 27/28, 37/38, 47/48 closed (X32 OFF). |
| | | OFF | 17/18, 27/28, 37/38, 47/48 open (X32 ON). |
| | SI | ON | 13/14, 23/24 closed (Y32 OFF). |
| | | OFF | 13/14, 23/24 open (Y32 ON). |
| | | Flashing | Safety input is closed, waiting for reset input. |

Indicators During Diagnostics **Table 10 - Status Indicators (Diagnostics)**

| Power / Status Indicator | Status/Faults |
|-------------------------------------|--|
| Solid red | <p>An undeclared fault has occurred. Momentary power interruption.</p> <p>CI, DI, and DIS: Short circuit has occurred, or is present, from A1 to S11 or S21 or from A2 to S11 or S21.</p> <p>DIS: Short circuit has occurred or is present from A1 to 14 or 24.</p> <p>SI: Excessive capacitance from input wiring to ground, but not enough to cause flashing red four times.</p> <p>Check the wiring. Cycle power to clear the fault and return the safety relay to an operational state.</p> |
| Flashing red one time | <p>The safety relay is in configuration mode.</p> <p>Continue with the configuration process. Rotate the switches to the desired positions and cycle power.</p> |
| Green with flashing red two times | <p>The configuration does not agree with the EEPROM.</p> <p>One or more of the rotary switches have changed during operation.</p> <p>The safety relay continues to operate, and the switches can be returned to their original position, while powered.</p> |
| Green with flashing red three times | <p>EMD: B2 is connected to B1, after configuration.</p> <p>Remove connection and fault is cleared automatically.</p> |
| Green with flashing red four times | <p>EMD: Set for non-retriggerable and Logic IN input is turned off and then back ON before the time expired.</p> <p>Cycle the Logic IN input signal to clear the fault or let the timer expire and the fault automatically clears.</p> <p>A connection was made from terminals B1 to B2, after configuration. Repeat the configuration process; the B1-B2 connection must be made before configuration.</p> |
| Flashing red two times | <p>Invalid configuration.</p> <p>Upon power-up, one or more of the rotary switch settings do not agree with the value that is stored in the EEPROM.</p> <p>Connections at S11 and S21 were swapped after configuration.</p> <p>Return the switches/wiring to their proper settings/terminals and cycle power; or reconfigure the relay.</p> |
| Flashing red three times | <p>Invalid configuration on DI or DIS safety relays.</p> <p>During configuration, the Logic switch is set for IN1 OR IN2 (position 1, 3, 5, or 7), but the inputs are wired for safety mats.</p> <p>If the inputs are not closed during configuration, the DI and DIS safety relays show this fault on the next power cycle if the inputs are closed.</p> <p>Reconfigure the relays for IN1 AND IN2 (position 2, 4, 6 or 8).</p> |
| Flashing red four times | <p>Cross fault.</p> <p>CI, DI, DIS, and SI: A short circuit has occurred or is present from S11 to S21.</p> <p>Excessive capacitance is detected on input wiring to ground. The pulse tests waveform is distorted.</p> <p>Check the wiring. Remove the short circuit and cycle the power.</p> |
| Flashing red five times | <p>Output test has failed on L11.</p> <p>CI: A short circuit has occurred, or is present, from A1 or S11 to L11.</p> <p>A short circuit has occurred, or is present, from A2 to L11 when L11 is ON.</p> <p>DI and DIS: Short circuit from L11 to L12.</p> <p>Short circuit from L11 to A1 on the next downstream relay.</p> <p>The 24V common connection to the downstream relay temporarily disconnected.</p> <p>Correct the fault and cycle power to the safety relays.</p> |
| Flashing red six times | <p>DIS: Output test has failed on 14, 24.</p> <p>External cross fault.</p> <p>High capacitance load.</p> <p>Check wiring. Remove fault or move high capacitance output connections to 34, 44. Cycle power to clear the fault.</p> |

Pulse Testing Functions

Safety relays use pulse testing of inputs and outputs to verify that the safety function is performed when called upon. Pulse testing for the inputs must be used with devices with mechanical contacts like E-stop push buttons, tongue operated interlock switches, and limit switches. The pulse testing cannot be turned on or off and cannot be changed.

The test pulses are used to detect three short circuit conditions:

- Between the input terminals and +24V.
- Between the input terminals and 24V common.
- Between the two input terminals.

Pulse Testing for Inputs

Pulse testing for the inputs is generated on terminals S11 and S21 of the CI, DI, DIS, and SI safety relays. The EM and EMD safety relays do not use pulse testing.

CI Safety Relay

The pulse testing that is associated with the CI safety relay is shown in [Figure 25](#). The pulse widths are 2.5 ms wide. The pulse testing on S11 and S21 is offset by 1 ms. The pulses are repeated every 14 ms.

Figure 25 - Pulse Test Sequence for CI Safety Relay

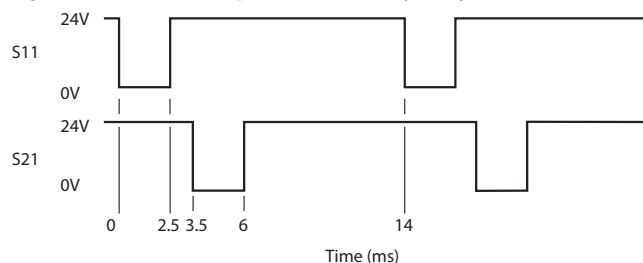

TIP When using a digital multimeter, S11 measures approximately 19V and S21 measures approximately 19V when the supply voltage to A1 is 24V DC and the input circuits are open.

At the minimum rated input ON voltage (11V), a DC multimeter reads approximately 8.9V DC at S12 and S22.

DI, DIS, and SI Safety Relays

The pulse test sequence for the DI, DIS, and SI safety relays are shown in [Figure 26](#). The sequence is repeated every 13.6 ms.

Figure 26 - Pulse Test Sequence for DI, DIS, and SI Safety Relays

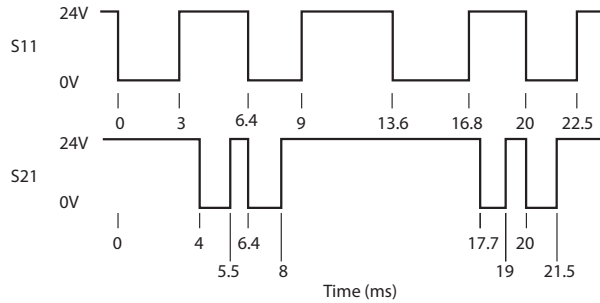

TIP When using a digital voltmeter, S11 measures approximately 14V DC and S21 measures approximately 18V DC when the supply voltage to A1 is 24V DC and the input circuits are open.

Pulse Testing for OSSD Outputs

The DIS safety relay has OSSD transistor outputs. One main transistor supplies current to four individual transistors ([Figure 27](#)). When the main transistor is pulse tested, the pulse appears on all outputs. When the individual transistors are tested, the pulse only appears on that transistor.

Figure 27 - Output Transistor Arrangement

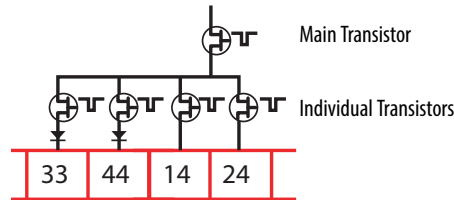

The pulse test pattern is shown in [Figure 28](#). The pulse widths vary from 50...150 μs. The pulse pattern on terminal 14 is identical to terminal 34, and the pulse pattern on 24 is identical to 44. The pattern is repeated every 3.371 seconds.

Figure 28 - OSSD Output Test Pulses on DIS Safety Relay

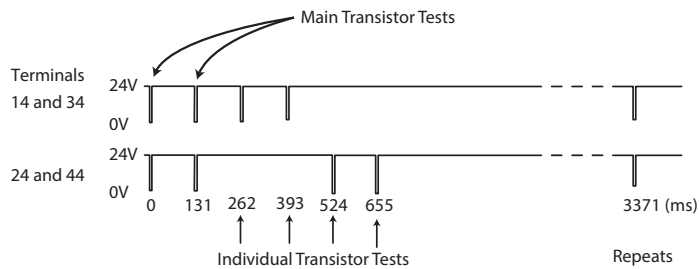

Although pulse tests appear on terminals 34 and 44, the DIS safety relay does not detect faults from A1 to 34, 44 or between 34 and 44 when the outputs are ON.

EMD Safety Relay Timing Functions

The EMD safety relay has three functions that use timing:

- Off delay
- On delay
- Jog

The off-delay timing depends on whether the function is retriggerable.

During the timing cycle, the Logic IN status indicator flashes.

Off Delay, Non-retriggerable

With input B1 open, the off-delay function is not retriggerable. The off-delay timer starts when the logic link signal at terminal L12 turns off. Once started, the off-delay timer runs for its full duration. [Figure 29](#) shows three cases of the timing sequences that can occur with this configuration.

Figure 29 - Off-delay, Non-retriggerable Timing Diagram

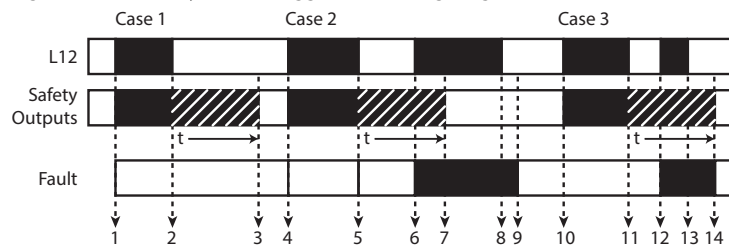

Case 1

1. The logic link signal at terminal L12 turns on, and the safety outputs turn on immediately (that is, within the specified reaction time).
2. The logic link signal turns off and the off-delay timer starts.
3. The off-delay time has elapsed, and the safety outputs turn off.

Case 2

4. The logic link signal at terminal L12 turns on, and the safety outputs turn on within the specified reaction time.
5. The logic link signal turns off, and the off-delay timer starts.
6. During off-delay time, the logic link signal turns off. A recoverable fault occurs. The PWR/Fault indicator is green and flashing red four times.
7. The off-delay time has elapsed, and the safety outputs turn off.
8. The logic link signal turns off.
9. Shortly after the logic link turns off, the fault is automatically cleared. The PWR/Fault indicator is solid green.

Case 3

10. The logic link signal at terminal L12 turns on, and the safety outputs turn on within the specified reaction time.
11. The logic link signal turns off and the off-delay timer starts.
12. During off-delay time, the logic link signal turns off. A recoverable fault occurs. The PWR/Fault indicator is green and flashing red four times.
13. The logic link turns back off. The fault continues to exist.
14. The off-delay time has elapsed; the safety outputs turn off; and the fault is automatically cleared.

Off Delay, Retriggerable

To use the retriggerable off-delay function, input terminal B1 must be connected to terminal B2 before the configuration process. The off-delay timer starts when the logic link signal at terminal L12 turns off. During the timing cycle, the off-delay timer is automatically reset to zero when the logic link turns back on. [Figure 30](#) shows two cases of the timing sequences that can occur with this configuration.

Figure 30 - Off-delay, Retriggerable Timing Diagram

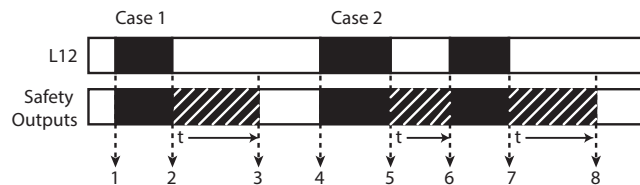

Case 1

1. The logic link signal at terminal L12 turns on, and the safety outputs turn on immediately (that is, within the specified reaction time).
2. The logic link signal turns off, and the off-delay timer starts.
3. The off-delay time has elapsed, and the safety outputs turn off.

Case 2

4. The logic link signal at terminal L12 turns on, and the safety outputs turn on within the specified reaction time.
5. The logic link signal turns off, and the off-delay timer starts.
6. During off-delay time, the logic link signal turns on. The off-delay timer is set back to zero, and the safety outputs remain on. No fault occurs.
7. The logic link signal turns off, and the off-delay timer starts.
8. The off-delay time has elapsed, and the safety outputs turn off.

On Delay

To use the on-delay function, terminal B1 must be an open connection. The on-delay timer starts when the logic link signal at terminal L12 turns on. The safety outputs turn on after the delay time expires and remain on until the logic link signal turns off. If the logic link signal turns off during the timing cycle, the safety outputs turn off immediately. [Figure 31](#) shows two cases of the timing sequences that can occur with this configuration.

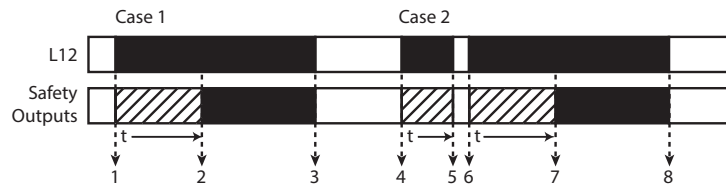
Figure 31 - On-delay Timing Diagram**Case 1**

1. The logic link signal at terminal L12 turns on, and the on-delay timer starts.
2. The on-delay timer elapses, and the safety outputs turn on.
3. When the logic link signal turns off, the safety outputs turn off.

Case 2

4. The logic link signal at terminal L12 turns on, and the on-delay timer starts.
5. The logic link signal turns off before the on-delay time elapses. The on-delay timer is reset to zero. No fault occurs.
6. After a brief interruption (even as short as 100 ms), the logic link signal turns back on. The on-delay timer starts from zero.
7. The on-delay timer elapses, and the safety outputs turn on.
8. When the logic link signal turns off, the safety outputs turn off.

Jog

The jog function has two timers: an on-timer and an off-timer. The Range and Time switch settings set the on-timer during configuration. The on-timer starts when both the B1 terminal is connected to 24V DC and the logic link signal at terminal L12 is on. The order in which these two signals turn on is not relevant. When both signals are on, the safety outputs turn on during the on-timer. After the on-timer expires, the safety outputs turn off and the off-timer starts. The off-timer is fixed at 500 ms. After the safety outputs turn off, they will remain off until the off-timer elapses. Then the jog can be restarted.

[Figure 32](#) shows three cases of timing sequences.

During the on-timer cycle, the Logic IN indicator flashes at a 1 Hz rate. During the off-timer cycle, the Logic IN indicator flashes at an 8 Hz rate.

Figure 32 - Jog Timing Diagram

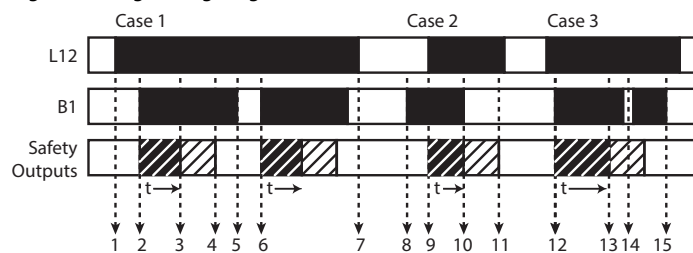

Case 1

1. The logic link signal at terminal L12 turns on.
2. The B1 terminal turns on. The jog on-timer starts, and the safety outputs turn on.
3. The jog on-timer elapses, and the safety outputs turn off. The jog off-timer starts.
4. After 500 ms, the jog function is complete.
5. The B1 inputs turn off.
6. With the logic link input still on, the jog function is repeated when the B1 signal turns on.
7. The logic link signal turns off.

TIP The L12 and B1 signals are interchangeable. The B1 signal can remain on and the L12 turns on and off to execute the jog function.

Case 2

8. The B1 signal turns on before the logic link signal.
9. The logic link signal turns on. The jog on-timer starts, and the safety outputs turn on.
10. The B1 signal turns off before on-timer elapses. The safety outputs turn off immediately and the off-timer starts.

11. The off-timer elapses. The logic link signal turns off to end Case 2.

TIP The L12 and B1 signals are interchangeable. If the B1 signal remains on and the L12 turns off before the on-timer elapses, the safety outputs turn off immediately.

Case 3

12. The logic link signal at terminal L12 is on. The B1 signal turns on. The jog on-timer starts, and the safety outputs turn on.

13. The on-timer elapses and the safety outputs turn off. The off-timer starts.

14. During the off-timer cycle, the B1 signal is turned off and then quickly back on. The safety outputs remain off.

15. The B1 signal must turn off before a new jog cycle can begin.

TIP The L12 and B1 signals are interchangeable. At least one of these two signals must remain off throughout the off-timer cycle before a new jog cycle begins.

Notes:

Internal Circuit Block Diagrams

The figures in this chapter show the internal circuit block diagrams of each safety relay.

CI Safety Relay (Cat. No. 440R-S13R2)

Figure 33 - CI Safety Relay Circuit Diagram

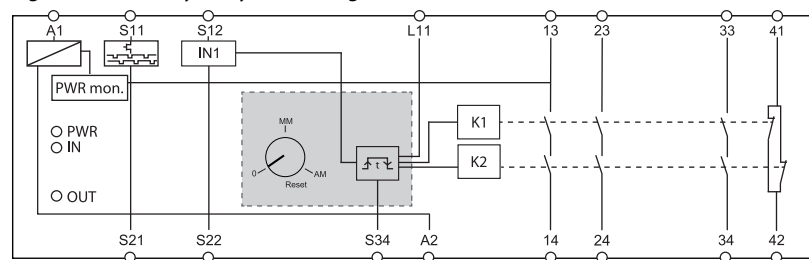

DI Safety Relay (Cat. No. 440R-D22R2)

Figure 34 - DI Safety Relay Circuit Diagram

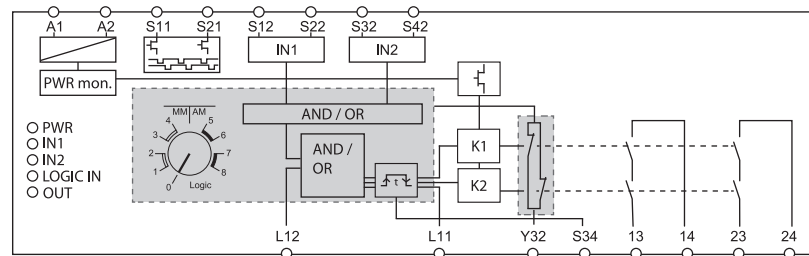

DIS Safety Relay (Cat. No. 440R-D22S2)

Figure 35 - DIS Safety Relay Circuit Diagram

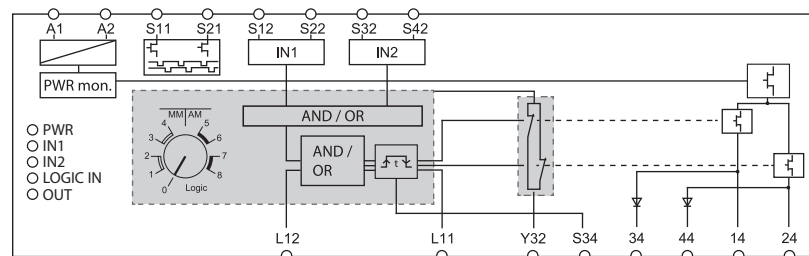

EM Safety Relay (Cat. No. 440R-EM4R2)

Figure 36 - EM Safety Relay Circuit Diagram

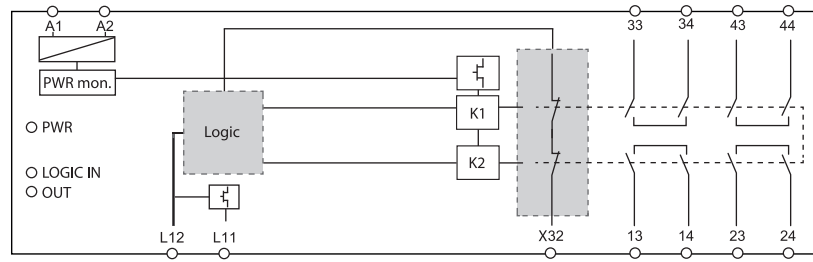

EMD Safety Relay (Cat. No. 440R-EM4R2D)

Figure 37 - EMD Safety Relay Circuit Diagram

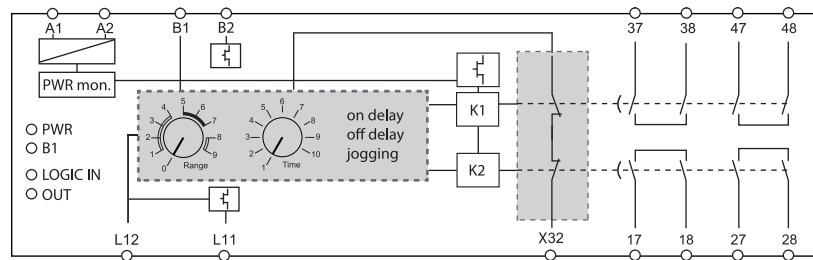

SI Safety Relay (Cat. No. 440R-S12R2)

Figure 38 - SI Safety Relay Circuit Diagram

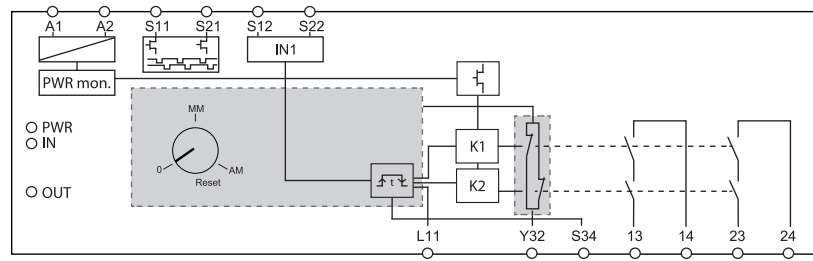

Application and Wiring Examples

The application and wiring examples in this chapter show you how to put the inputs and outputs together to create an operating safety system. These circuit diagrams are examples; many features are interchangeable between relays.

Publication [SAFETY-WD001](#) provides additional application and wiring diagrams.

CI Safety Relay (Cat. No. 440R-S13R2)

In [Figure 39](#), the CI safety relay is monitoring a device (an E-stop push button) with mechanically operated contacts. The CI safety relay is configured for monitored manual (MM) reset. The output turns on if the E-stop is released and the reset push button is pressed and released between 0.25...3 seconds. The CI safety relay monitors the status of the two output contactors, K1 and K2. If either fails to close their N.C. contacts, the CI safety relay does not reset. An auxiliary signal, terminals 41/42, is sent to the PLC when the E-stop is pressed.

Figure 39 - Mechanical Contacts with Monitored Manual Reset

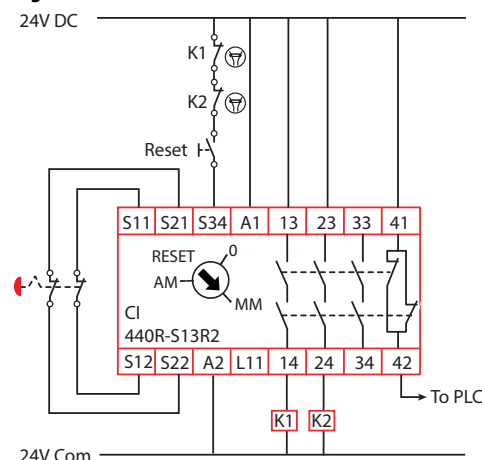
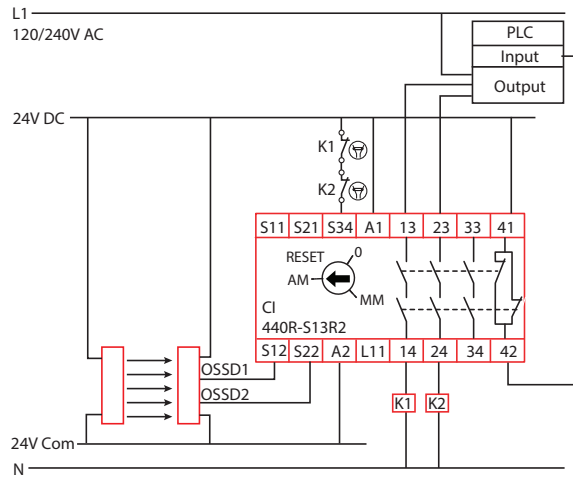

Figure 40 shows a CI relay monitoring a light curtain with two OSSD outputs. The CI is set to automatic/manual reset (AM). The auxiliary signal (terminals 41/41) informs the PLC that the safety system is OFF or ON. The CI outputs connect to AC voltage loads. When the CI safety relay is ON, the PLC can then turn on the K1 and K2 contactors.

Figure 40 - With Device Using OSSD Outputs, Automatic Reset, AC Load Voltage



DI Safety Relay (Cat. No. 440R-D22R2)

The DI safety relay in Figure 41 monitors two devices having mechanical contacts and is set for monitored manual reset. With the two devices closed, the operator presses the reset button to energize contactors K1 and K2. The DI safety relay verifies that contactors K1 and K2 are off by monitoring the mechanically linked normally closed contacts in the reset circuit. When the DI safety relay is off, the auxiliary signal at terminal Y32 turns on and reports the status to a PLC.

Figure 41 - With Two Devices with Mechanical Contacts and Monitored Manual Reset

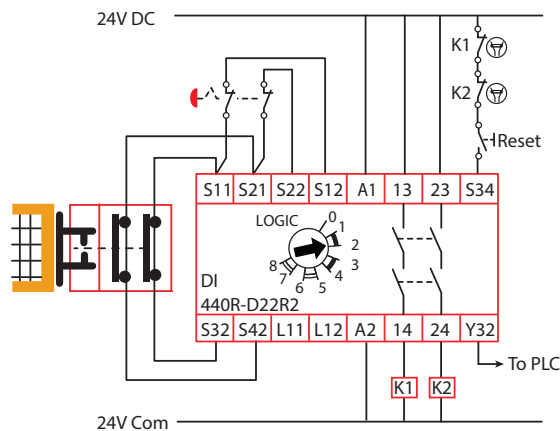

In [Figure 42](#), a DI safety relay monitors a safety mat and non-contact interlock with OSSD outputs. Make note of the specific wiring for the mat. Also, during configuration and for each power-up, the mat must be clear and the interlock closed. The DI safety relay must be configured for AND logic for the two inputs. The DI safety relay logic setting is 6: (IN1 AND IN2) OR L12 with automatic reset. The DI safety relay verifies that contactors K1 and K2 are off by monitoring the mechanically linked normally closed contacts in the S34 circuit. When the DI safety relay is off, the auxiliary signal at terminal Y32 turns on and reports the status to a PLC. Per ISO 13856-1, safety mat applications require a manual reset function. For fault detection purposes, all GSR relays used for safety mat control must be configured for monitored manual reset.

Figure 42 - With a Safety Mat and Device with OSSD Outputs, Monitored Manual Reset, AC Loads

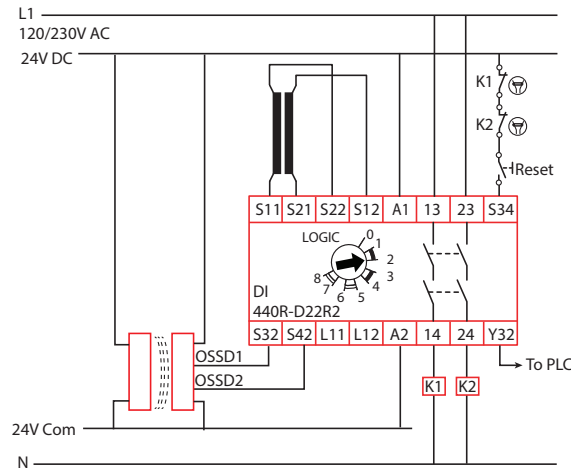

DIS Safety Relay (Cat. No. 440R-D22S2)

[Figure 43](#) shows the DIS safety relay with only one device. The DIS and DI safety relay can monitor one device by configuring the relay for OR logic. The DIS safety relay logic setting is 1: (IN1 OR IN2) OR L12 with monitored manual reset. The second input (terminals S32 and S42) requires no connection. With solid-state outputs, the contactors K1 and K2 must be 24V DC powered coils. The DIS safety relay verifies that contactors K1 and K2 are off by monitoring the mechanically linked normally closed contacts in the S34 circuit. When the DIS safety relay is off, the auxiliary signal at terminal Y32 turns on and reports the status to a PLC.

Figure 43 - Single Input, Monitored Reset

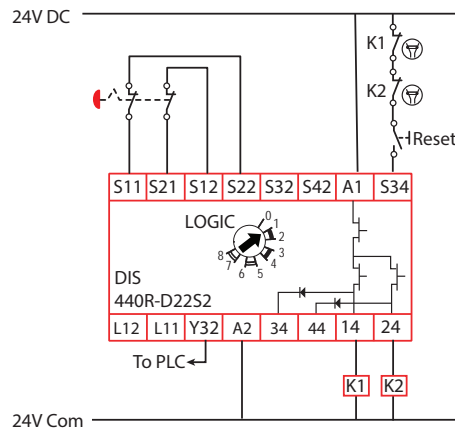

The DIS safety relay monitors two devices with OSSD outputs in [Figure 44](#). The DIS safety relay logic setting is 6: (IN1 AND IN2) OR L12 with automatic reset. The output terminals 34 and 44 are designed to tolerate higher capacitance loads (but lower resistive load) as compared to terminals 14 and 24.

Figure 44 - High Capacitive Load

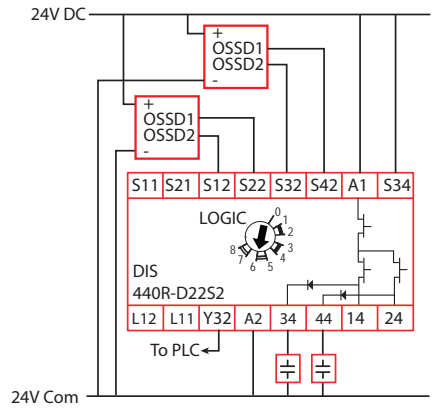

EM Safety Relay (Cat. No. 440R-EM4R2)

The EM safety relay in [Figure 45](#) expands the number of outputs of the DI safety relay. The single wire safety signal from terminal L11 to L12 instructs the EM safety relay to turn on and off. The EM safety relay outputs mimic the DI safety relay outputs. The DI safety relay monitors contactors K1...K6 and the status of the EM safety relay by sourcing the reset signal from the X32 terminal on the EM safety relay.

Figure 45 - Expansion of Immediate Safety Outputs

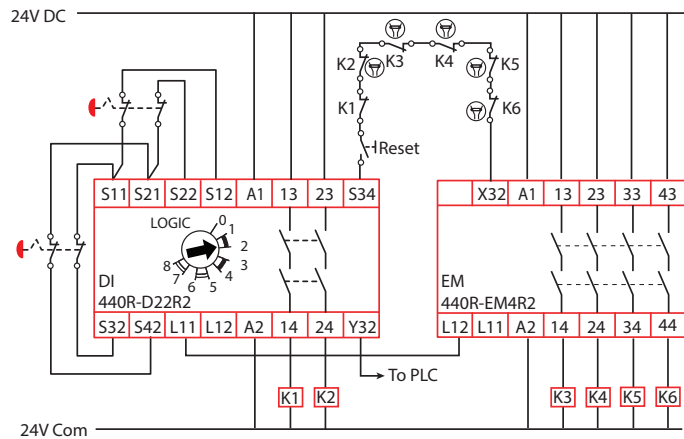

EMD Safety Relay (Cat. No. 440R-EM4R2D)

The EMD safety relay in [Figure 46](#) is configured for a 5 second off-delay. The single wire safety signal from terminals L11 to L12 instructs the EMD safety relay to turn on and off. When the E-stop is pressed, the CI safety relay turns off immediately and the EMD safety relay turns off 5 seconds later. The CI safety relay monitors contactors K1...K6 and the status of the EMD safety relay by sourcing the reset signal from the X32 terminal on the EMD safety relay.

In this example, the jumper from B1 to B2 makes the EMD safety relay retriggerable. If the E-stop is released and the reset is pressed within the 5 second delay time, the outputs of the EMD safety relay do not turn off because the internal timer is retriggered.

Figure 46 - EMD - Off Delay

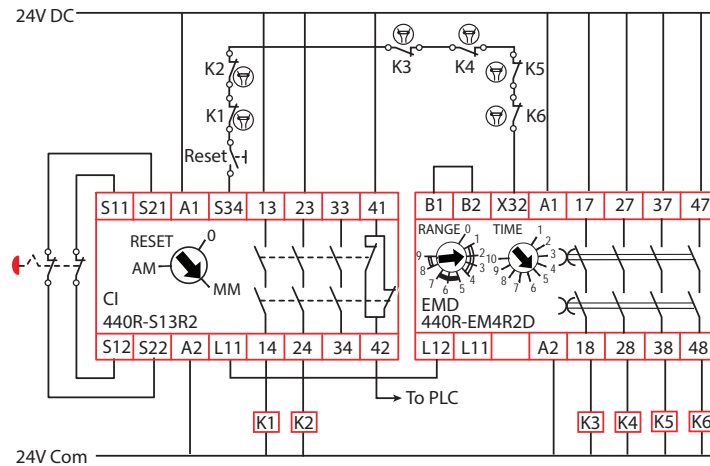

[Figure 47](#) shows the EMD safety relay that is configured for a 2.1 second on-delay. The single wire safety signal from terminals L11 to L12 instructs the EMD safety relay to turn on and off. When the reset button is pressed, the DIS safety relay outputs turn on immediately. After a 2.1 second delay, the EMD safety relay outputs turn on.

The DIS safety relay monitors contactors K1...K4 and the status of the EMD safety relay by sourcing the reset signal from the X32 terminal on the EMD safety relay.

Figure 47 - EMD - On Delay

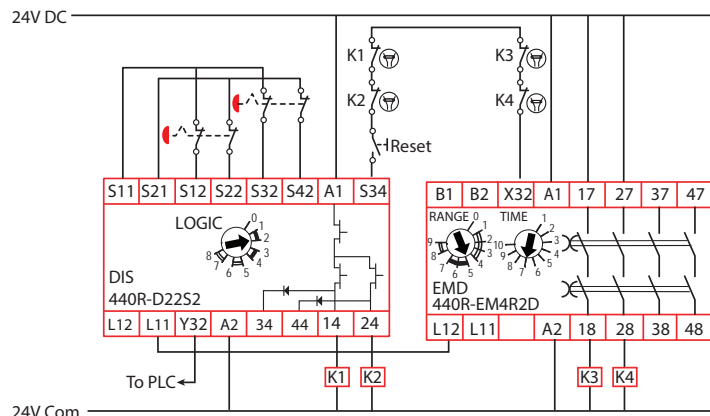

The EMD safety relay in [Figure 48](#) is configured for a maximum of a 100-second jog. The single wire safety signal from terminals L11 to L12 enables the EMD safety relay. When enabled, the jog switch can be pressed and held closed to turn on the EMD safety relay outputs. If the jog button is released before the 100 second time, the EMD safety relay outputs turn off. If the jog button is held longer than 100 seconds, the EMD safety relay outputs only turn on for 100 seconds.

Figure 48 - EMD - Jog

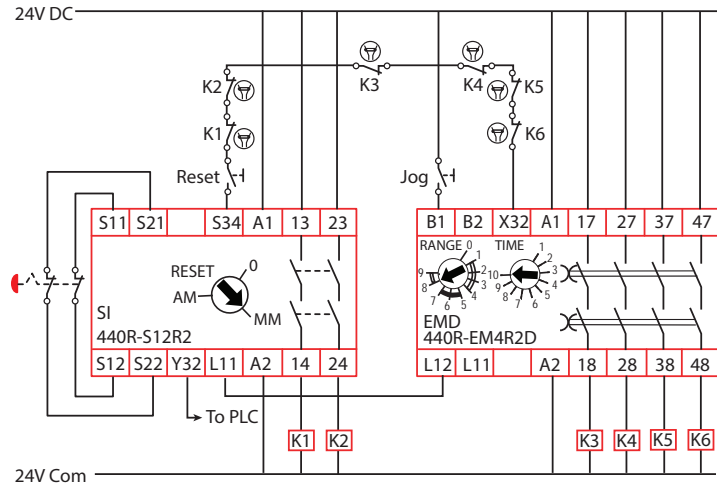

SI Safety Relay (Cat. No. 440R-S12R2)

The SI safety relay monitors a gate interlock with mechanical contacts in [Figure 49](#). The SI safety relay is configured for automatic reset. When the gate is closed, the SI safety relay outputs turn on if contactors K1 and K2 are already off. The Start button can then be pressed to turn on contactors K1 and K2.

Figure 49 - SI Example

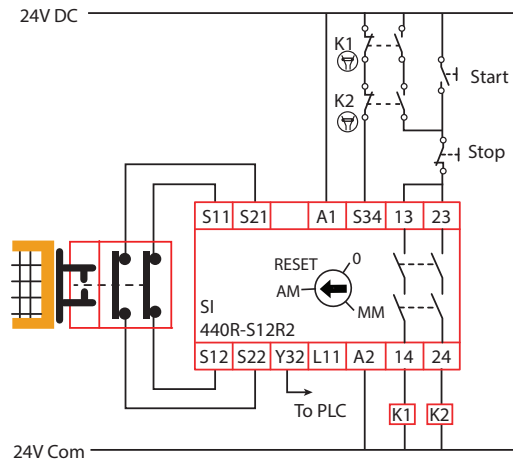

Ethernet Communication

The DI, DIS, EM, EMD, and SI safety relays are equipped with optical communication via an optical link. With an optical link, diagnostic data can be read from these relays and transferred to other devices over EtherNet/IP with the catalog number 440R-ENETR EtherNet/IP module. The CI safety relay does not have an optical link.

The catalog number 440R-ENETR EtherNet/IP module must be in the left-most position ([Figure 50](#)). See publication [440R-UM009](#) for further details on the EtherNet/IP module. The safety relays must be Series A 200 or later.

Figure 50 - Arrangement of EtherNet/IP Module and Safety Relays

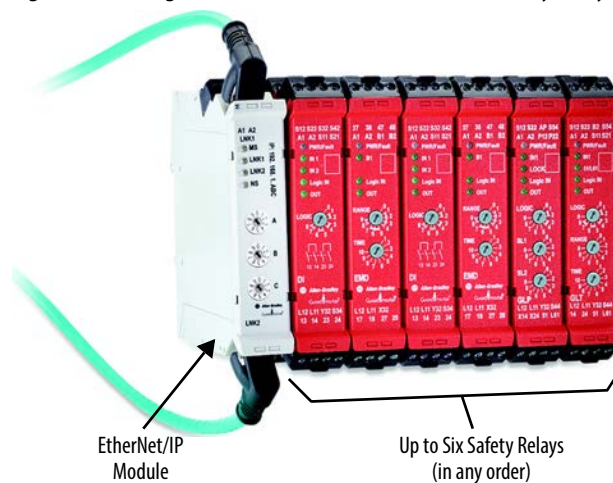

Web Page

The catalog number 440R-ENETR EtherNet/IP module maintains its own web page (Figure 51). To access the web page, connect an Ethernet cable to your computer, open a web browser, and type in the IP address of the ENETR module.

Figure 51 - ENETR Web Page

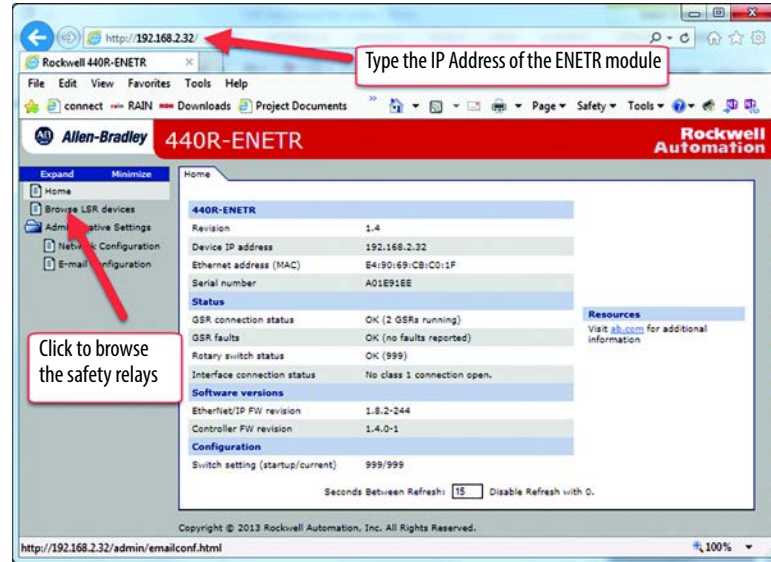

Studio 5000 Logix Designer Add-on Profile (AOP)

The catalog number 440R-ENETR EtherNet/IP module includes the Studio 5000 Logix Designer® AOP for the DI, DIS, EM, EMD, and SI safety relays. The AOP allows you to view the status of the relays, including open and closed inputs, outputs ON and OFF, waiting for reset, and fault information. Figure 52 shows an example of the AOP for the DI safety relay.

See publication [440R-UM009](#) for further details on the EtherNet/IP module.

Figure 52 - AOP for the DI Safety Relay

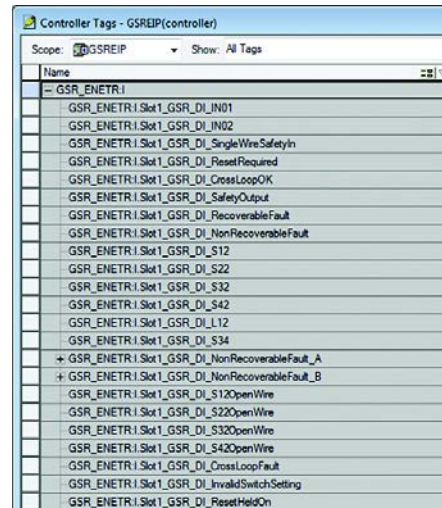

Specifications

General

Table 11 - General Specifications

| Attribute | 440R-S13R2 (CI) | 440R-D22R2 (DI) | 440R-D22S2 (DIS) | 440R-EM4R2 (EM) | 440R-EM4R2D (EMD) | 440R-S12R2 (SI) |
|-------------------------------------|--|-----------------|------------------|-----------------|-------------------|-----------------|
| Dimensions, HxWxD [mm (in)] | 119.14 x 22.5 x 113.6 (0.88 x 4.69 x 4.47) | | | | | |
| Shipping Weight, Approx. [g (lb)] | 225 (0.5) | 180 (0.4) | 50 (0.33) | 225 (0.5) | 220 (0.49) | 150 (0.33) |
| Wire Size [mm ² (AWG)] | 0.2...2.5 (24...14) | | | | | |
| Wiring Category | Copper that withstands 75 °C (167 °F) | | | | | |
| Terminal Screw Torque [N-m (lb-in)] | 0.4 (4) | | | | | |
| Power Supply Voltage Range | 24V DC PELV/SELV, 0.85...1.1 x rated voltage | | | | | |
| Power On Delay [s] | 5.5 | | | | | |
| Power Consumption [W] | 3.5 | 2.5 | 2 | 3.5 | 3.5 | 2.5 |
| Case Material | Polyamide PA 6.6 | | | | | |
| Terminal Protection | IP20 | | | | | |
| Enclosure Protection | IP40 (NEMA 1) | | | | | |
| Mounting | 35 mm DIN rail in enclosure that is rated to a minimum of IP54 | | | | | |

Environmental

Table 12 - Environmental Specifications

| Attribute | 440R-S13R2 (CI) | 440R-D22R2 (DI) | 440R-D22S2 (DIS) | 440R-EM4R2 (EM) | 440R-EM4R2D (EMD) | 440R-S12R2 (SI) |
|----------------------------------|--------------------------------------|-----------------|------------------|-----------------|-------------------|-----------------|
| Temperature, Operating [°C (°F)] | -5...+55 (23...131) | | | | | |
| Relative Humidity | 90% | | | | | |
| Vibration | 10...55 Hz, 0.35 mm | | | | | |
| Shock | 10 g, 16 ms | | | | | |
| Pollution Level | 2 | | | | | |
| Installation Group | Overvoltage Category III, VDE 0110-1 | | | | | |
| Impulse Withstand Voltage | 2500V | | | | | |

Safety Inputs IN, IN1, and IN2

Table 13 - Safety Inputs IN, IN1 and IN2 Specifications

| Attribute | 440R-S13R2 (CI) | 440R-D22R2 (DI) | 440R-D22S2 (DIS) | 440R-EM4R2 (EM) | 440R-EM4R2D (EMD) | 440R-S12R2 (SI) |
|--|--------------------|-----------------------|-----------------------|-----------------|-------------------|--------------------|
| Inputs | 1 NC, 1 PNP (OSSD) | 2 NC, 2 PNP (OSSD) | 2 NC, 2 PNP (OSSD) | — | — | 1 NC, 1 PNP (OSSD) |
| Wiring Terminals | S12, S22 | S12, S22 and S32, S42 | S12, S22 and S32, S42 | — | — | S12, S22 |
| ON Voltage | Max [V] | 26.4 | | — | — | 26.4 |
| | Min [V] | 11 | | — | — | 11 |
| OFF Voltage, Max [V] | 5 | | — | — | 5 | |
| OFF Current, Max [mA] | 2 | | — | — | 2 | |
| ON Current, Max | At 24V DC [mA] | 11.0 | | — | — | 11.0 |
| | At 26.4V DC [mA] | 11.1 | | — | — | 11.1 |
| Galvanic Isolation: I/O from Logic | No | | — | — | No | |
| Overvoltage Protection | Yes | | — | — | Yes | |
| Test Out Pulse | Duration [ms] | 2.5 | 1.5, 3 | — | — | 1.5, 3 |
| | Period [ms] | 14 | 13.6 | — | — | 13.6 |
| Off Pulse Accepted for OSSD Setting Without Declaring the Input as OFF, Max [ms] | 3.1 | 2.2 | | — | — | 2.2 |
| Recovery Time, Min [ms] | 30 | | — | — | 30 | |
| Reverse Voltage Protection | Yes | | — | — | Yes | |
| Input Capacitance [nF] | 10 | | — | — | 10 | |
| Input Simultaneity | Infinite | | — | — | Infinite | |
| Allowable Input Resistance, Max (Ω) | 900 | | — | — | 900 | |
| Allowable Cable Capacitance, Max [nF] | S11 to S21 | 350 | 160 | — | — | 160 |
| | S11 to Gnd | 350 | 320 | — | — | 320 |
| | S21 to Gnd | 350 | 320 | — | — | 320 |
| Safety Mat, Max Size [m ²] | 23 | 35 | | — | — | 35 |

Reset Input

Table 14 - Reset Input Specifications

| Attribute | 440R-S13R2 (CI) | 440R-D22R2 (DI) | 440R-D22S2 (DIS) | 440R-EM4R2 (EM) | 440R-EM4R2D (EMD) | 440R-S12R2 (SI) |
|------------------------------------|------------------|-----------------|------------------|-----------------|-------------------|-----------------|
| Wiring Terminal | S34 | | — | — | — | S34 |
| ON Voltage | Max [V] | 26.4 | | — | — | 26.4 |
| | Min [V] | 11 | | — | — | 11 |
| OFF Voltage, Max [V] | 5 | | — | — | 5 | |
| OFF Current, Max [mA] | 2 | | — | — | 2 | |
| ON Current, Max | At 24V DC [mA] | 11.0 | | — | — | 11.0 |
| | At 26.4V DC [mA] | 11.1 | | — | — | 11.1 |
| Galvanic Isolation: I/O from Logic | No | | — | — | No | |
| Overvoltage Protection | Yes | | — | — | Yes | |
| Input Capacitance [nF] | 10 | | — | — | 10 | |
| Duration [s] | 0.5...3.0 | | — | — | 0.5...3.0 | |

B1 Input

Table 15 - B1 Input Specifications

| Attribute | 440R-S13R2 (CI) | 440R-D22R2 (DI) | 440R-D22S2 (DIS) | 440R-EM4R2 (EM) | 440R-EM4R2D (EMD) | 440R-S12R2 (SI) |
|------------------------------------|------------------|-----------------|------------------|-----------------|-------------------|-----------------|
| Wiring Terminal | — | — | — | — | B1 | — |
| ON Voltage | Max [V] | — | — | — | 26.4 | — |
| | Min [V] | — | — | — | 11 | — |
| OFF Voltage, Max [V] | — | — | — | — | 5 | — |
| OFF Current, Max [mA] | — | — | — | — | 2 | — |
| ON Current, Max | At 24V DC [mA] | — | — | — | 11.0 | — |
| | At 26.4V DC [mA] | — | — | — | 11.1 | — |
| Galvanic Isolation: I/O from Logic | — | — | — | — | No | — |
| Overvoltage Protection | — | — | — | — | Yes | — |
| Input Capacitance [nF] | — | — | — | — | 10 | — |

Safety Outputs

Table 16 - Safety Outputs Specifications

| Attribute | 440R-S13R2 (CI) | 440R-D22R2 (DI) | 440R-D22S2 (DIS) | 440R-EM4R2 (EM) | 440R-EM4R2D (EMD) | 440R-S12R2 (SI) |
|---|---|---------------------|--|---|----------------------------------|---|
| Wiring Terminal | 13/14, 23/24, 33/34 | 13/14, 23/24 | 14, 24, 34, 44 | 13/14, 23/24, 33/34, 43/44 | 17/18, 27/28, 37/38, 47/48 | 13/14, 23/24 |
| Output Type | 3 N.O. | 2 N.O. | 4 PNP | 4 N.O. | 4 N.O. delayed | 2 N.O. |
| Thermic Current I_{th} | 1 x 6 A | | — | 1 x 6 A | | |
| Fuses output (external) | 6 A slow blow or 10 A quick blow | | — | 6 A slow blow or 10 A quick blow | | |
| Switched Current, Min [mA] | 10 | | — | 10 | | |
| Switched Voltage, Min [V] | 10 | | — | 10 | | |
| Mechanical Life | 10,000,000 cycles | | — | 10,000,000 cycles | | |
| Rating | UL: C300 AC-15: 1.5 A / 250V AC DC13: 2 A / 24V DC (0.1 Hz) | | 14, 24: 1.5 A each 34, 44: 0.5 A each | UL: B300 AC-15: 1.5 A / 250V AC DC13: 2 A / 24V DC (0.1 Hz) | | UL: C300 AC-15: 1.5 A / 250V AC DC13: 2 A / 24V DC (0.1 Hz) |
| Capacitance | — | | 14, 24: 1.6 μ F each 34, 44: 9 μ F each | — | | |
| Contact material | AgNi | AgNi + 0.2 μ Au | — | AgNi | | |
| Reaction Time Safety Output [ms] | L12 | 45 | 35 | 100 | 150 | 150 |
| | Inputs | 35 | 25 | | | |
| | Mat Operation | 40 | 30 | | | |
| Reaction Time Single Wire Safety Output [ms] | L12 | 35 | 35 | 0 | 150 | — |
| | Inputs | 25 | 25 | | | 25 |
| | Mat Operation | 30 | 30 | | | 30 |
| Response Time Safety Output [ms] | Inputs | 35 | 25 | 35 | | 35 |
| | Mat Operation | 45 | 40 | | | 45 |
| Response Time Single Wire Safety Output [ms] | Inputs | 25 | 25 | 25 | | 25 |
| | Mat Operation | 35 | 30 | | | 35 |
| | Single-wire Fault | 45 | 45 | | | 45 |
| Recovery Time [ms] | 100 | 100 | 100 | 150 | 150 | 100 |

Auxiliary Output

Table 17 - Auxiliary Output Specifications

| Attribute | 440R-S13R2 (CI) | 440R-D22R2 (DI) | 440R-D22S2 (DIS) | 440R-EM4R2 (EM) | 440R-EM4R2D (EMD) | 440R-S12R2 (SI) |
|-----------------|-----------------|------------------|------------------|-----------------|-------------------|-----------------|
| Wiring Terminal | — | Y32 | | X32 | | Y32 |
| Output Type | 1 N.C. | 1 PNP, 50 mA max | | | | |

Single Wire Safety

Table 18 - Single Wire Safety (SWS) Specifications

| Attribute | 440R-S13R2 (CI) | 440R-D22R2 (DI) | 440R-D22S2 (DIS) | 440R-EM4R2 (EM) | 440R-EM4R2D (EMD) | 440R-S12R2 (SI) |
|---|-----------------------------|-----------------|------------------|-----------------|-------------------|-----------------|
| Wiring Terminal | Output - L11 Input - L12 | | | | | |
| Continuous Output Current, Max [mA] | 50 | | | | | |
| ON State Voltage Drop (P/S to +), Max [V] | 0.2 | | | | | |
| Surge Output Current, Max [mA] | 700 | | | | | |
| Surge Output Current Duration, Max [ms] | 5 | | | | | |
| Load Capacitance, Max [µF] | 1 | | | | | |
| Off State Leakage Current, Max [mA] | < 0.1 | | | | | |
| Short Circuit Detection | No | | | | | |
| Short Circuit Protection | Yes | | | | | |
| Galvanic Isolation: I/O from Logic | No | | | | | |
| Fanout (Max number of connections to L11) | 10 | | | | | |
| Cable length between L11 and L12 [m] | 30 | | | | | |

Regulatory Approvals

Agency Certifications

- UL Listed Industrial Control Equipment, certified for US and Canada.
- CE marked for all applicable directives
- C-Tick marked for all applicable acts
- CCC Mark
- S-Mark

Compliance to European Union Directives

This product has the CE marking and is approved for installation within the European Union and EEA regions. It has been designed and tested to meet the following directives.

EMC Directive

This product is designed and tested to meet the European Council Directive 2004/108/EC on Electromagnetic Compatibility (EMC) and the following standards:

- EN 61000-6-4: Generic Standards - Emission Standard for Industrial Environments
- EN 61000-6-2: Generic Standards - Immunity for Industrial Environments

This product is intended for use in an industrial environment.

Machine Safety Directive

This product is designed and tested to meet the European Council Directive 2006/42/EC on machinery and the following standards.

- IEC/EN 61508 - Functional safety of electrical/electronic/programmable electronic safety-related systems
- IEC/EN 62061 - Safety of machinery - Functional safety of safety-related electrical, electronic, and programmable electronic control systems
- EN ISO 13849-1 - Safety of machinery -- Safety-related parts of control systems -- Part 1: General principles for design

This product is intended for use in an industrial environment.

The performance of the safety function is dependent on the structure of all devices that comprise the safety function. [Table 19](#) and [Table 20](#) provide the data that must be used to represent safety relays when calculating the safety integrity level (SIL) or the Performance Level (PL).

Safety relays can be used in safety circuits according to DIN EN 60204-1/VDE 0113 part 1. The following safety requirements are achievable in maximum based on the operation mode and wiring.

Specifications are applicable only if the safety function is demanded at least once within six months. All diagnostic tests are conducted at least before next demand. At mission time (TM), the proof test interval (PTI) is assumed. Components failure rates are according to SN29500.

SIL Rating

Safety relays meet the requirements in [Table 19](#) in accordance with IEC/EN 61508 and IEC 62061.

Table 19 - SIL Rating

| | 440R-S13R2 (CI) | 440R-D22R2 (DI) | 440R-D22S2 (DIS) | 440R-EM4R2 (EM) | 440R-EM4R2D (EMD) | 440R-S12R2 (SI) |
|------------------------------------|-----------------|-----------------|------------------|-----------------|-------------------|-----------------|
| PFH (1/h) | 4.26 E-09 | 4.35 E-09 | 4.39 E-09 | 1.81 E-09 | 4.40 E-09 | 3.98 E-09 |
| Safety Integrity Level Claim Limit | 3 | | | | | |
| Mode of Operation | High demand | | | | | |
| Hardware Fault Tolerance | 1 | | | | | |
| Safe Failure Fraction | 99% | | | | | |

Performance Level/Category

Safety relays can be used in safety systems that meet up to Category 4 and Performance Level PLe in accordance with ISO 13849-1

Table 20 - Performance Level/Category

| | 440R-S13R2 (CI) | 440R-D22R2 (DI) | 440R-D22S2 (DIS) | 440R-EM4R2 (EM) | 440R-EM4R2D (EMD) | 440R-S12R2 (SI) |
|--------------------|-----------------|-----------------|------------------|-----------------|-------------------|-----------------|
| MTTFd | 164 | 355 | 484 | 190 | 165 | 262 |
| Category | Up to 4 | | | | | |
| Performance Level | Up to e | | | | | |
| DC avg | 99% | | | | | |
| Mission Time | 20 years | | | | | |
| Days of Operation | 365 days | | | | | |
| Hours of Operation | 24 hr | | | | | |
| T cycle | 8 hr / 8.28 s | | | | | |

A

- add-on profile**
 - Studio 5000 Logix Designer 56
- adjust**
 - switch 34
- adjustment**
 - switch 32
- agency certifications** 61
- AOP**
 - Studio 5000 Logix Designer 56
- application**
 - examples 49
 - CI safety relay 49
 - DI safety relay 50
 - DIS safety relay 51
 - EM safety relay 52
 - EMD safety relay 53
 - SI safety relay 54
- apply power** 34
- approvals**
 - regulatory 61
- assignments**
 - terminal 18
- automatic**
 - reset 27
- auxiliary output** 27
 - specifications 60

B

- B1 input**
 - specifications 59

C

- category** 62
- certifications**
 - agency 61
- CI safety relay**
 - overview 10
- circuit block diagram** 47, 48
- communication**
 - Ethernet 55
- compliance**
 - European Union (EU) directives 61
- configuration** 31
 - process 34
- connect**
 - power supply 19
- considerations**
 - enclosure 14
- cycle**
 - power 35

D

- devices**
 - mechanical contacts 20
 - safety, OSSD outputs 21
- DI safety relay**
 - overview 10
 - safety mat 51
 - switch adjustment 32
- diagnostics**
 - indicators 38
- diagram**
 - internal circuit block 47
 - CI safety relay 47
 - DI safety relay 47
 - DIS safety relay 47
 - EM safety relay 48
 - EMD safety relay 48
 - SI safety relay 48
- dimensions**
 - mounting 13
- DIN rail** 13
 - mounting 13
 - removal 13
- directive**
 - EMC 61
 - European Union 61
 - machine safety 61
- DIS safety relay**
 - overview 10
 - switch adjustment 32

E

- electromechanical**
 - output 24
- EM safety relay**
 - overview 11
- EMC**
 - directive 61
- EMD safety relay**
 - overview 11
 - switch adjustment 33
 - timing functions 41
- enclosure**
 - considerations 14
- environmental**
 - specifications 57
- Ethernet**
 - communication 55
- European Union (EU) directives**
 - compliance 61
- examples**
 - application 49
 - CI safety relay 49
 - DI safety relay 50
 - DIS safety relay 51
 - EM safety relay 52
 - EMD safety relay 53
 - SI safety relay 54

- wiring 49
 - CI safety relay 49
 - DI safety relay 50
 - DIS safety relay 51
 - EM safety relay 52
 - EMD safety relay 53
 - SI safety relay 54

excessive heat

- prevent 15

expansion relays

- monitor 29

F**features**

- hardware 9

functions

- pulse testing 39

G**general**

- specifications 57

ground

- relay 19

Guardmaster safety relay

- CI 10, 47, 49
- DI 10, 32, 47, 50
- DIS 10, 32, 47, 51
- EM 11, 48, 52
- EMD 11, 33, 41, 48, 53
- SI 11, 48, 54

H**hardware**

- features 9

heat

- prevent excessive 15

I**indicators**

- diagnostics 38
- normal operation 37
- powerup 37
- status 37

input

- jog 29
- monitor 27
- pulse testing 39
 - CI safety relay 39
 - DI, DIS, and SI safety relay 40
- reset 27
- retriggerable 29
- safety 20
- single wire safety 26
- SWS 26

installation**internal circuit block**

- diagram 47

- CI safety relay 47
- DI safety relay 47
- DIS safety relay 47
- EM safety relay 48
- EMD safety relay 48
- SI safety relay 48

J**jog**

- input 29

M**machine safety**

- directive 61

manual

- reset 27

mats

- safety 23

mechanical contacts

- devices 20

monitor

- expansion relays 29
- input 27

monitored reset**mounting**

- dimensions 13
- DIN rail 13

multi-position

- switch 10

N**non-retriggerable**

- off delay 41

normal operation

- indicators 37

O**off delay**

- non-retriggerable 41
- retriggerable 42

on delay

- 43

optical communication bus**OSSD output****OSSD outputs**

- pulse testing 40
- safety devices 21

output

- auxiliary 27
- electromechanical 24
- OSSD 24
- safety 24
- single wire safety 26
- SWS 26

overview 9

- CI safety relay 10
- DI safety relay 10
- DIS safety relay 10
- EM safety relay 11
- EMD safety relay 11
- SI safety relay 11

P**performance level** 62**power** 17

- apply 34
- cycle 35

power supply

- connect 19

powerup

- indicators 37

prepare

- switch 34

prevent

- excessive heat 15

process

- configuration 34

pulse testing

- functions 39
- input 39
 - CI safety relay 39
 - DI, DIS, and SI safety relay 40
- OSSD outputs 40

R**rating**

- SIL 62

recommendation

- wiring 17

regulatory approvals 61**relay**

- ground 19

removable

- terminals 14
- terminal blocks 9

removal 13**requirements**

- wiring 17

terminals

- removable 14

reset

- automatic 27
- input 27
- input, specifications 58
- manual 27
- monitored 28

retriggerable

- input 29
- off delay 42

S**safety**

- input 20
- mats 23
- output 24

safety inputs IN, IN1, and IN2

- specifications 58

safety mat

- DI safety relay 51

safety outputs

- specifications 59

safety relay

- CI 10, 47, 49
- DI 10, 32, 47, 50
- DIS 10, 32, 47, 51
- EM 11, 48, 52
- EMD 11, 33, 41, 48, 53
- SI 11, 48, 54

settings

- verify 35

SI safety relay

- overview 11

SIL

- rating 62

single wire safety

- input 26
- output 26
- specifications 60

spacing 14**specifications** 57

- auxiliary output 60
- B1 input 59
- environmental 57
- general 57
- reset input 58
- safety inputs IN, IN1, and IN2 58
- safety outputs 59
- single wire safety 60
- SWS 60

status indicators 9, 37

- diagnostics 38
- normal operation 37
- powerup 37

Studio 5000 Logix Designer

- add-on profile (AOP) 56

suppressors

- surge 25

surge suppressors 25**switch**

- adjust 34
- adjustment 32
 - DI safety relay 32
 - DIS safety relays 32
 - EMD safety relay 33
- multi-position 10
- prepare 34

SWS

- input 26
- output 26
- specifications 60

T

terminal

- assignments 18
- torque 17

terminal blocks

- removable 9

timing functions

- EMD safety relay 41

torque

- terminal 17

troubleshooting 37

V

verify

- settings 35

W

web page 56

wire 17

- size 17

wiring

- examples 49
 - CI safety relay 49
 - DI safety relay 50
 - DIS safety relay 51
 - EM safety relay 52
 - EMD safety relay 53
 - SI safety relay 54
- recommendation 17
- requirements 17

Rockwell Automation Support

Use the following resources to access support information.

| | | |
|---|---|---|
| Technical Support Center | Knowledgebase Articles, How-to Videos, FAQs, Chat, User Forums, and Product Notification Updates. | https://rockwellautomation.custhelp.com/ |
| Local Technical Support Phone Numbers | Locate the phone number for your country. | http://www.rockwellautomation.com/global/support/get-support-now.page |
| Direct Dial Codes | Find the Direct Dial Code for your product. Use the code to route your call directly to a technical support engineer. | http://www.rockwellautomation.com/global/support/direct-dial.page |
| Literature Library | Installation Instructions, Manuals, Brochures, and Technical Data. | http://www.rockwellautomation.com/global/literature-library/overview.page |
| Product Compatibility and Download Center (PCDC) | Get help determining how products interact, check features and capabilities, and find associated firmware. | http://www.rockwellautomation.com/global/support/pcdc.page |

Documentation Feedback

Your comments will help us serve your documentation needs better. If you have any suggestions on how to improve this document, complete the How Are We Doing? form at http://literature.rockwellautomation.com/idc/groups/literature/documents/du/ra-du002_-en-e.pdf.

Rockwell Automation maintains current product environmental information on its website at <http://www.rockwellautomation.com/rockwellautomation/about-us/sustainability-ethics/product-environmental-compliance.page>.

Allen-Bradley, Atlas, Cadet, Elf, Ferrogard, Guardmaster, GuardShield, Kinetix, Lifeline, PowerFlex, Rockwell Automation, Rockwell Software, Rotacam, SafeZone, SensaGuard, Sipha, Studio 5000 Logix Designer, and Trojan are trademarks of Rockwell Automation, Inc.

EtherNet/IP is a trademark of ODVA, Inc.

Rockwell Otomasyon Ticaret A.Ş., Kar Plaza İş Merkezi E Blok Kat:6 34752 İçerenköy, İstanbul, Tel: +90 (216) 5698400

www.rockwellautomation.com

Power, Control and Information Solutions Headquarters

Americas: Rockwell Automation, 1201 South Second Street, Milwaukee, WI 53204-2496 USA, Tel: (1) 414.382.2000, Fax: (1) 414.382.4444

Europe/Middle East/Africa: Rockwell Automation NV, Pegasus Park, De Kleetlaan 12a, 1831 Diegem, Belgium, Tel: (32) 2 663 0600, Fax: (32) 2 663 0640

Asia Pacific: Rockwell Automation, Level 14, Core F, Cyberport 3, 100 Cyberport Road, Hong Kong, Tel: (852) 2887 4788, Fax: (852) 2508 1846

Publication 440R-UM013D-EN-P – December 2016

Supersedes Publication 440R-UM013C-EN-P – July 2016

Copyright © 2016 Rockwell Automation, Inc. All rights reserved. Printed in the U.S.A.