

GUIDE

Guide for Scaffolds and Other Elevated Work Platforms



**SAFE
WORK**
MANITOBA™

This guide was developed to provide practical information to help employers and workers erect, use and maintain scaffolding and other elevated work platforms safely at the workplace. It also outlines the requirements of the regulation on scaffolding and other elevated work platforms. For more detailed information on regulatory requirements regarding scaffolds, please refer to Part 28 of the *Workplace Safety and Health Regulation*.

Acknowledgements

SAFE Work Manitoba gratefully acknowledges the Canadian Standards Association (CSA) and the Government of Alberta, Employment and Immigration, for permission to use illustrations from their publications in this guide.

Certain illustrations on pages 54 through 61 are reproduced with the permission of the CSA from the following:

- *CAN/ CSA B354.4 – Self Propelled Boom-Supported Elevating Work Platforms*
- *CAN/CSA B354.2 – Self Propelled Elevating Work Platforms*
- *CAN/CSA B354.1 – Portable Elevating Work Platforms*
- *CAN/CSA C225 – Vehicle-Mounted Aerial Devices*
- *CAN/CSA B354.5 – Mast-Climbing Work Platforms*

These illustrations are copyrighted by CSA Standards, 5060 Spectrum Way, Suite 100, Mississauga, ON L4W 5N6. While use of this material has been authorized, the CSA shall not be responsible for the manner in which the information is presented, nor for any interpretations thereof.

Certain other illustrations are reproduced with the permission of Alberta Employment and Immigration from the *OHS Code Explanation Guide 2006*, Part 23, Sections 324, 329, 336 and 343.

Some content in this guide is based on information provided courtesy of the Construction Safety Association of Ontario (CSAO), Work Safe Alberta, WorkSafeBC, and the United States Department of Labour, Occupational Safety and Health Administration.

Created: July 2016

Last reviewed/revised: 2016



GUIDE

for Scaffolds and Other Elevated Work Platforms

TABLE OF CONTENTS

Introduction	4
Responsibilities	4
Employers	4
Workers using scaffolds.....	5
Supervision	5
Design/Approvals	5
Design/Approvals.....	5
Engineer design	6
CSA Standard	6
Scaffold Selection	6
Selection	6
Provisions for Particular Types of Scaffolds	7
Lean-to scaffold	7
Ladder-jack scaffold.....	8
Bracket Scaffold.....	8
Outrigger scaffold	9
Pump jack scaffold.....	9
Standard tubular frame scaffold	10
Walk-through (masonry) frame scaffold	11
Rolling (mobile) scaffolds	12
Fold-up Scaffold Frames	13
Adjustable scaffolds (Baker scaffold).....	13
Tube-and-clamp (coupler) scaffolds	14
Single pole – Tube and clamp scaffolding	15
Scaffold Foundation and Support	16
Scaffold Erection and Bracing	17
Fittings and accessories	17
Base plates and screw jacks.....	17
Plumbing (Levelling)	17
Bracing.....	17
Coupling devices.....	17



Wheels or casters.....	18
Hoisting materials	18
Dismantling	18
Scaffold Access.....	19
Fall protection	19
Ladders	21
Scaffold Work Platforms.....	23
Aluminum/Plywood platform panels	23
Laminated Veneer Lumber	24
Sawn lumber planks.....	24
Sawn lumber plank inspection criteria.....	24
Guardrails.....	26
Scaffold Stability.....	27
Three-to-one rule	27
Outrigger stabilizers	27
Characteristics: Rope, wire rope and tiebacks	28
Covers.....	30
Wind uplift	30
Scaffolding Use and Maintenance.....	31
Typical loads and requirements	31
Housekeeping	32
Inspection.....	32
Scaffold Inspection Checklist	33
Suspended Scaffolds	34
Criteria for suspension scaffolds.....	35
Single-point adjustable (Boatswain's chairs)	37
Two-point adjustable (swing stage).....	38
1. Work platform (stage).....	39
2. Suspension system	39
1. Thrust-outs (Outrigger beams).....	39
2. Counterweight determination.....	39
3. Securing of counterweights	40
4. Thrust-out overhang.....	42
5. Thrust-out tie-backs.....	43
6. Parapets	44
7. Suspension to thrust-out	44
8. Wire rope	45
9. Rigging hardware	45
10. Wire rope clips	45
11. Wire rope inspection	47
12. Cornice hooks.....	47
3. Hoisting apparatus.....	48
4. Permanent window washing facilities	49



Interior hung	50
Suspended man baskets	51
Aerial Devices and Self-Elevating Work Platforms	53
1. Self-elevating work platforms	53
a. Self-propelled boom supported elevating work platforms.....	54
b. Self-propelled elevating work platforms	56
c. Portable elevating work platforms	57
2. Vehicle-mounted aerial devices	58
Specific requirements	60
a. Ladder trucks and tower trucks	60
b. Extensible and articulating boom platforms	60
Mast-climbing Work Platforms	61
Vehicle-Mounted Bridge Inspection and Maintenance Devices	64
Lift Truck Mounted Work Platforms.....	66
Appendix A.....	68
Appendix B.....	70
Glossary of Terms.....	71



INTRODUCTION

In Manitoba, a variety of scaffold types are used as temporary work platforms, supporting workers, materials and equipment above ground level.

This guideline provides practical information and minimum safety requirements for employers and workers to assemble, use and maintain scaffolding and other elevated work platforms in good condition at the workplace.

RESPONSIBILITIES

Employers

Except for work of short duration that can be done safely from a ladder, employers must provide workers with a scaffold or elevated work platform to use for work that cannot be done from the ground or other safe elevation. Employers are responsible for ensuring that proper scaffolding material and equipment is provided at project sites.

When a scaffold or elevated work platform is required at a workplace, the employer must develop safe work procedures for work involving the scaffold or elevated work platform; train workers in those safe work procedures; and ensure workers comply with those procedures. The safe work procedures must include emergency response and rescue plans in case the scaffold/elevated work platform fails.

If scaffolds are designed by a professional engineer, employers must ensure they are constructed, installed, used, maintained and dismantled according to the design (see: *Design and approval*).

Employers must appoint one or more competent persons to supervise the erection, installation, dismantling and removal of the scaffold system. These people are responsible for inspecting the components of the scaffold for defects each day it is used, before allowing workers to use it. They must ensure any defective components are repaired or replaced before the scaffold is used.

Prime contractors should ensure scaffolding is erected and maintained according to regulatory requirements, manufacturer's specifications, and appropriate safe work procedures and engineers' designs are available on site.

Employers must ensure that:

- scaffolds do not bear loads greater than what they are rated for
- workers are informed of their rated load
- workers do not carry any materials or equipment while climbing a scaffold
- adequate overhead protection is provided for workers under the part of a scaffold that is being installed, altered or dismantled; or in situations where there is a risk of material falling on a worker on the scaffold platform or in the area of the scaffold.

Workers using scaffolds

Workers must follow the safe work procedures developed for the workplace and use all necessary equipment and personal protective devices when erecting, installing, using and dismantling scaffold systems.

Workers must wear safety footwear and headwear when installing and working on a scaffold system. An employer must ensure that a worker who installs, alters or dismantles a scaffold uses a fall protection system that meets the requirements of Part 14 (Fall Protection) of the *Workplace Safety and Health Regulation*.

Supervision

Scaffolds must be installed under the supervision of at least one competent person experienced in the scaffold's installation and use. Although scaffold systems vary among manufacturers, certain basic requirements are common to all scaffold systems. The supervisor should be on site and able to review that the scaffold is installed according to the manufacturer's recommendations or engineer's design.

DESIGN/APPROVALS

Design/approvals

Employers must ensure that a scaffold is erected, installed, used, maintained and dismantled according to the manufacturer's specifications. Only a professional engineer may alter the specifications.

When a commercially manufactured scaffold is used at a workplace, the employer must ensure that a copy of the manufacturer's specifications and any alterations certified by a professional engineer are readily accessible at the workplace.

Employers must ensure that a scaffold and its footing, sills and similar supports can safely support at least four times the maximum load placed on them.

An employer must ensure that the scaffold is installed plumb and stabilized by having its vertical and horizontal members braced to prevent undesired movement.

The scaffold must be tied securely to the building or structure, or to a fixed support, at intervals recommended by a professional engineer or by the manufacturer – but in no case at vertical and horizontal intervals of more than three times the minimum lateral dimension of the scaffold.

The scaffold must be equipped with a ladder, stair, runway or ramp that provides a safe means of worker access and egress. Toe boards must exist on the open sides of the scaffold platform where there is a risk of tools, materials, equipment or debris falling from the platform.

All scaffold openings, including stairway openings, must be properly guarded.



Engineer design

All open access scaffolding more than 10 m (33 ft.) in height, and all fully or partially enclosed scaffolding more than 7.5 m (25 ft.) in height, must be designed by a professional engineer.

Employers must ensure that the specifications for constructing, installing, using, maintaining and dismantling engineer-designed scaffolding are certified by a professional engineer and applied by workers. A copy of the scaffold design, including all specifications, must be accessible at the work site where it is used.

Employers must ensure engineered designed scaffolding systems are inspected after assembly and installation, and prior to use. Professional engineers should inspect the assembly after erection.

CSA Standard

The standard for access scaffolding, *CSA Z797-09 Code of Practice for Access Scaffold*, provides criteria for the design of access scaffolding, including loads and forces, structural analysis and design, erection, dismantling, safety requirements, maintenance and test procedures.

Part 28, sections 28.3 and 28.4 of the *WSH Regulation*, takes precedence over any provision in the CSA Standard that may differ from requirements in the regulation.

SCAFFOLD SELECTION

Selection

Safe and efficient use of scaffolding depends on choosing the right system for the job. If the scaffold is unsuited to the task, or if necessary components are not available, assembly and use are compromised.

Selection of scaffolding and related components requires an understanding of site conditions and the work to be undertaken.

Employers must consider:

- the weight of workers, tools, materials and equipment to be carried by the scaffold system (safe work load)
- site conditions (interior, exterior, backfill, concrete floors, type and condition of walls, access for the equipment, variations in elevation, anchorage points, etc)
- height to which the scaffold may be erected (overhead power lines, tiebacks and engineered requirements)
- type of work that will be done from the scaffold (masonry work, sandblasting, painting, metal siding, mechanical installation, suspended ceiling installation)
- duration of work
- weather conditions, including wind and ice buildup
- requirements for pedestrian traffic through and around the scaffold area
- means of access to the scaffold
- configuration of the building or structure being worked on
- special assembly or dismantling circumstances
- temporary fencing to limit unapproved access.

PROVISIONS FOR PARTICULAR TYPES OF SCAFFOLDS

Lean-to scaffold

A lean-to scaffold is a supported scaffold kept erect by tilting it towards and resting it against a building or structure. It must not be higher than 5 m (16.40 ft.) above grade.

Lean-to scaffolds with wood planks must not be spaced more than 2.5 m (8 ft.) apart. The scaffold decking or work platform must be 500 mm (19.69 in.) wide if made from wood planks, or 400 mm (15.75 in.) wide if made from a commercially manufactured plank. Decking must not be placed more than 300 mm (12 in.) from the wall or structure that the A-frames have been placed against.

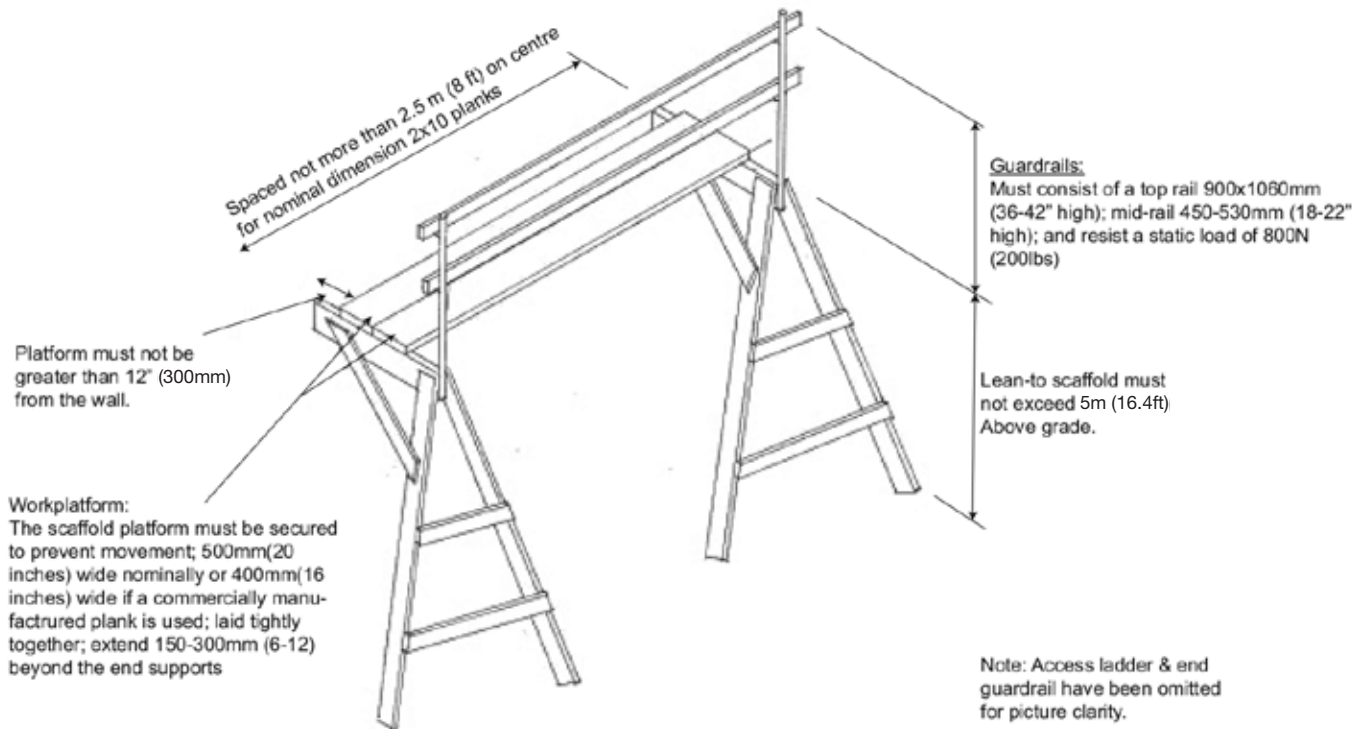

Ladder-jack Scaffold

Ladder-jack scaffolding consists of a work platform mounted on jacks that bear on both the side rails and the ladder rungs of two extension ladders.

A ladder-jack scaffold must be designed and constructed as required by ANSI Standard A10.8, Safety Requirements for Scaffolding — *American National Standard for Construction and Demolition Operations*.

The ladders must not be spaced more than 2.5 m (8.2 ft.) apart. They must not exceed a height of more than five metres (16.4 ft) above grade, and a fall protection system is required for working at heights of more than 3 m (10 ft.). The jacks must bear on both the side rails and the ladder rungs, or the ladder rungs only, but only if the bearing area of each rung is at least 254mm (10 in.)



The ladder-jack scaffolding must be maintained as level as possible. No more than two workers are allowed to work on a ladder-jack scaffold at any time. Extension ladders must be secured from movement.

Bracket Scaffold

Bracket scaffolds have their brackets hung from supporting structures, such as the top plate of a wall. The work platform consists of planks with vertical guardrail supports. The guardrail will consist of a top rail 900 to 1060 mm (35.4 in. - 41.76 in.) high, a mid-rail 450 to 530 mm (17.72 in. - 20.87 in.) high, and be able to resist 900 N (200 lbs.) of force. The brackets are to be securely attached and spaced no more than 3 m (118.08 in.) apart. (Note: M.R. 217/2006, Part 28 Section 28.10(3) does not apply to a bracket scaffold).

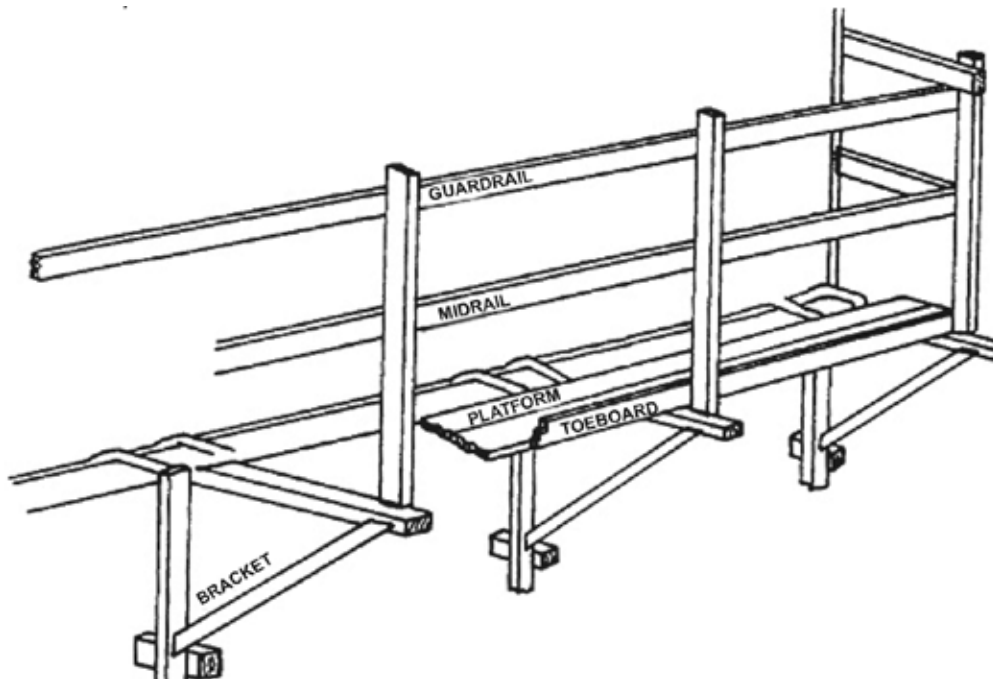

Outrigger Scaffold

An outrigger scaffold consists of a platform resting on outrigger beams or thrust-outs. The beams project beyond the wall or face of the building or structure, with inboard ends secured inside the building or structure.

An outrigger scaffold must be built and loaded according to specific standards or according to the design of a professional engineer. The scaffold is not to be used to store construction materials or as a crane loading platform.

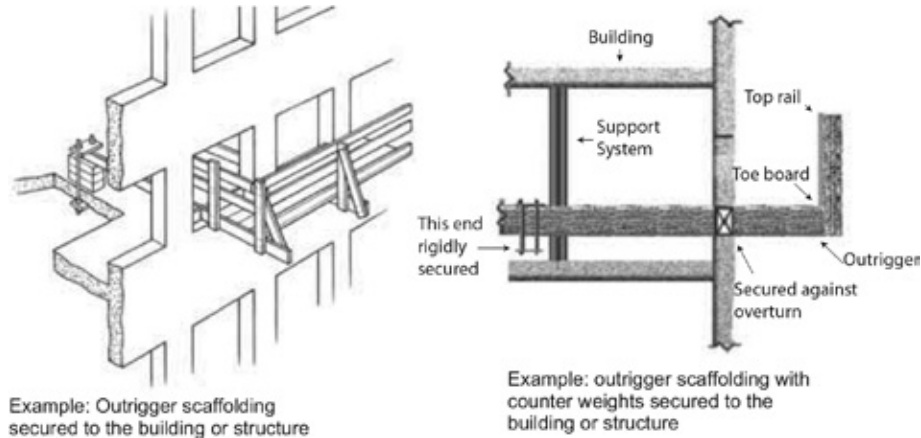

The length of the outrigger beams should be greater than 1.5 times the length of the outboard end measured from the fulcrum point to the extreme point of anchorage. The beams must rest on the edge (narrow side) with the sides plumb and the edges horizontal. The fulcrum point is to rest on secure 150 mm (6 in.) bearings. Beams are secured to prevent movement and braced at the fulcrum point to prevent tipping.

Pump Jack/Power Pole Scaffold

A pump jack scaffold consists of a platform supported by vertical poles (aluminum or wood) and movable support brackets. The platform travels up and down by way of foot pump/mechanical drives attached to the poles. Never allow more than two people between any two poles of this type of scaffold.

Brackets, braces and accessories for pump jack scaffolds must be made from metal plates and angles. Two positive gripping devices are required for each bracket. Poles must be secured to structures by firm triangular bracing or its equivalent at the top and other points.

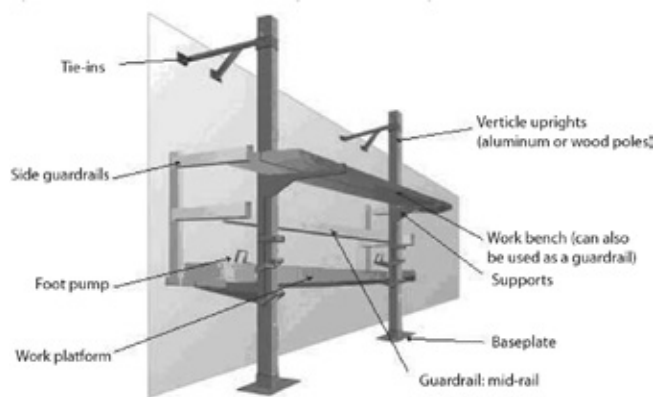

If wood poles are used, the lumber must be straight-grained, free of shakes and large, loose or dead knots, or other imperfections that may reduce the strength of the wood.



Standard Tubular Frame Scaffold

This is the most frequently used scaffolding system in Manitoba's construction industry. It is made of steel or aluminum tubing and manufactured in various designs and spans.

The advantages of this scaffold type are portability and ease of assembly.

All necessary base plates, shore heads, extension devices or screw jacks must be securely installed and attached to the sills and the legs of the frame. If frames are stacked, they must be secured so that no gaps between the lower end of one frame and the upper end of the frame below it are present.

Most manufacturers have braces that will provide spans between 1.5 m (4.92 ft.) and 3 m (9.84 ft.) in length. Some manufacturers also make shorter or longer braces.

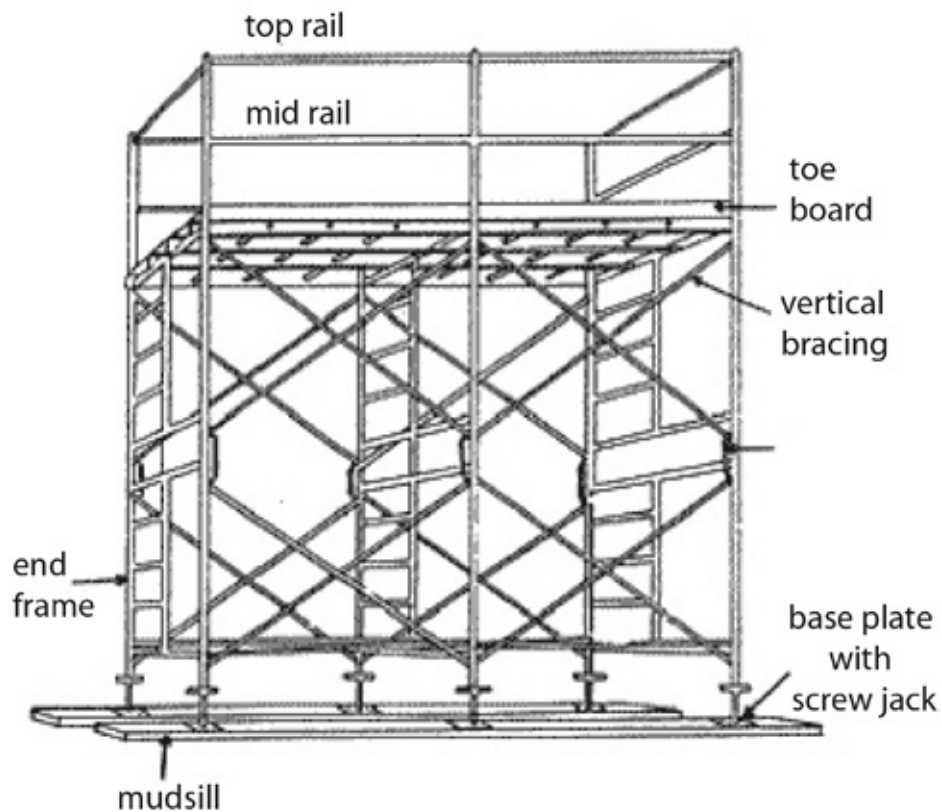

Walk-Through (Masonry) Frame Scaffold

A walk-through frame scaffold is a variation of the tubular frame type. It is frequently used in the masonry trade to provide greater height per tier, along with easier movement and distribution of materials on platforms.

Consideration must be given to pedestrian safety. All pedestrians must be protected from falling debris and materials.

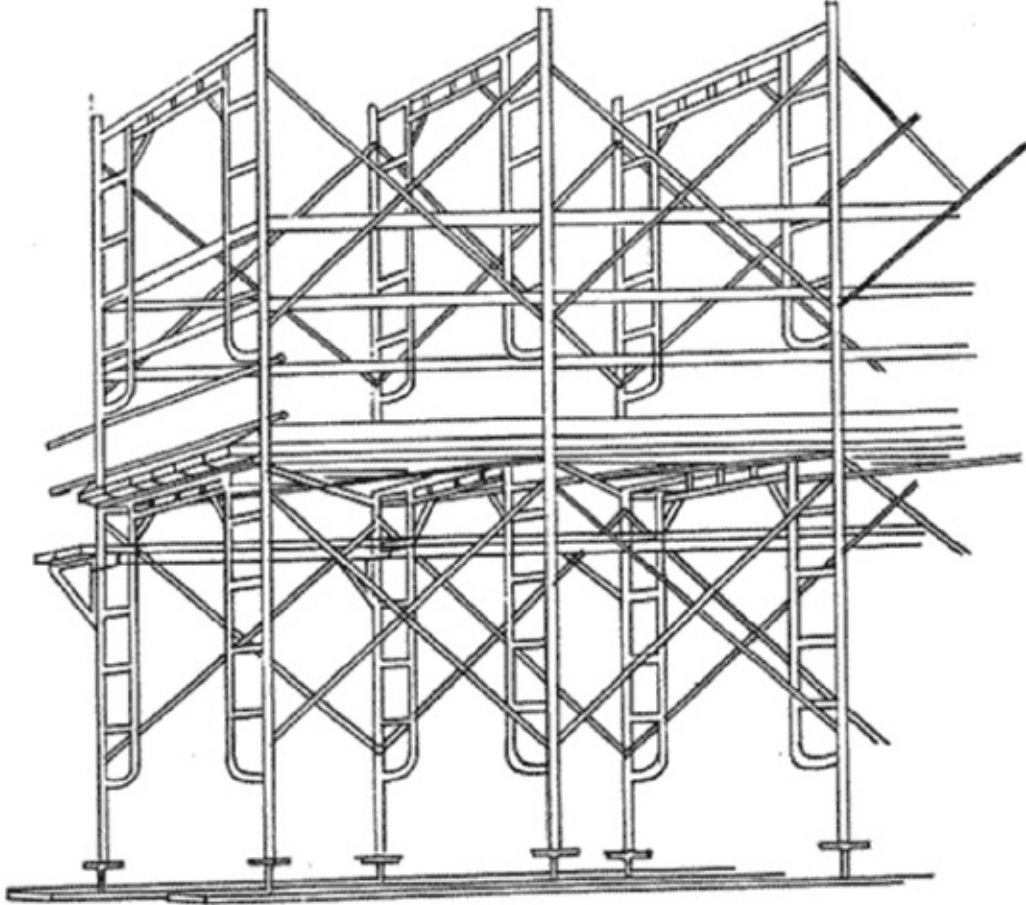

Rolling (Mobile) Scaffolds

Scaffolds that need to be moved frequently are often equipped with casters or wheels. Mobile scaffolds must only be used on firm, level ground. Once erected, the scaffolding must be stable. If its height is more than three times its least length or width measured at the base, it must be equipped with outriggers, tie backs or other means necessary to prevent it from overturning. Mobile scaffolding must have casters or wheels that are equipped with suitable braking devices or be blocked to prevent the scaffolding from moving and rated to support the load imposed on it. If it has pneumatic tires, then outriggers or stabilizers must be used to ensure the tires do not support the weight of the scaffold when it is not being moved.

Rolling scaffolds must be securely pinned together and be fitted with horizontal, diagonal bracing as recommended by the manufacturer.

Small wheels are suitable for pavement or concrete floors. Larger pneumatic wheels are necessary where the ground is the working surface. Rolling scaffolds must always be used on a surface that is firm, free of obstructions and level. All brakes must be applied when the scaffold reaches the desired position.

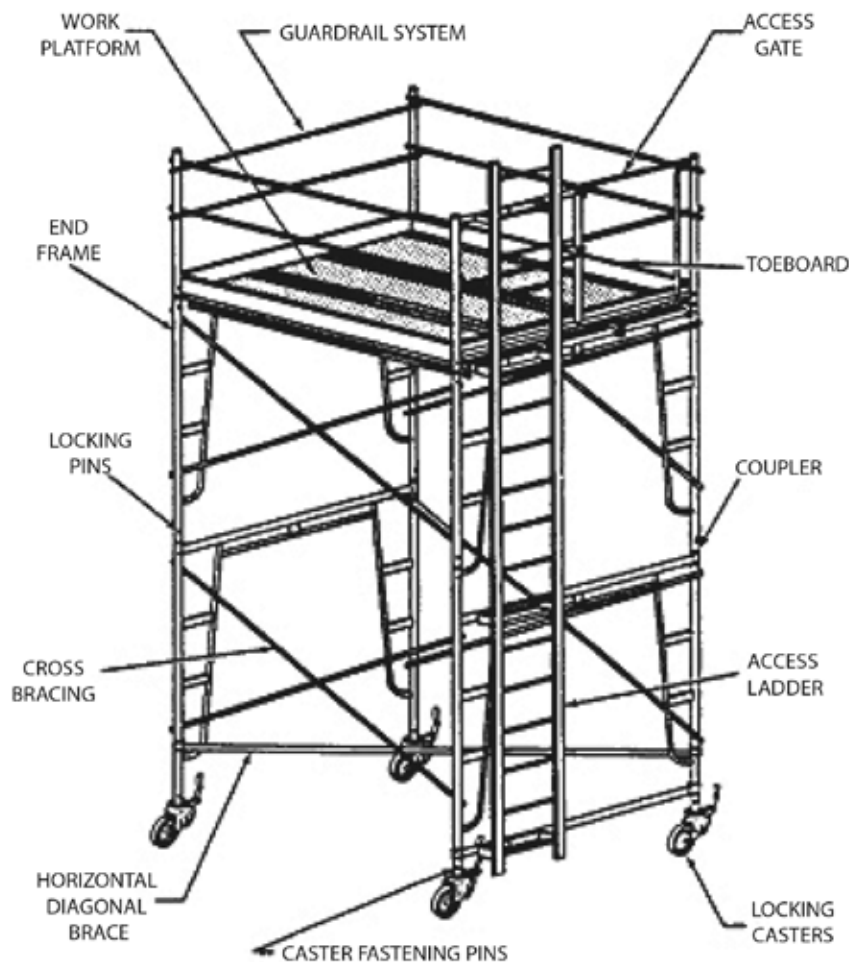

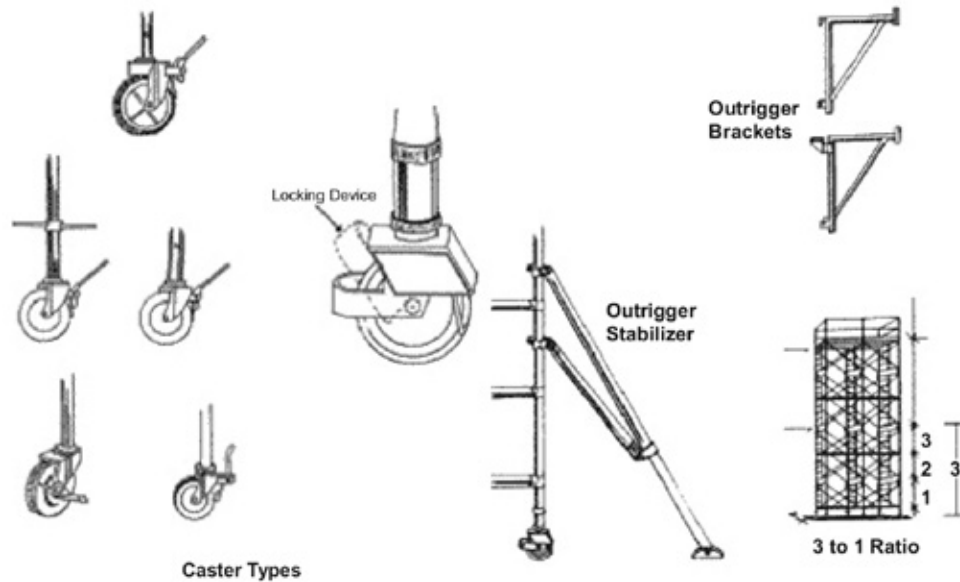

Fold-up Scaffold Frames

Electricians, painters, suspended ceiling workers and other trades people often use fold-up scaffolds. Widths range from 330 mm (13 in.) to the standard width of about 1.5 m (5 ft.). Usually made of aluminum, this type of scaffold is moved about construction sites and from job to job quickly and easily. It must have a fully decked work platform and casters with brakes. It should be used on a smooth, hard surface **only**.

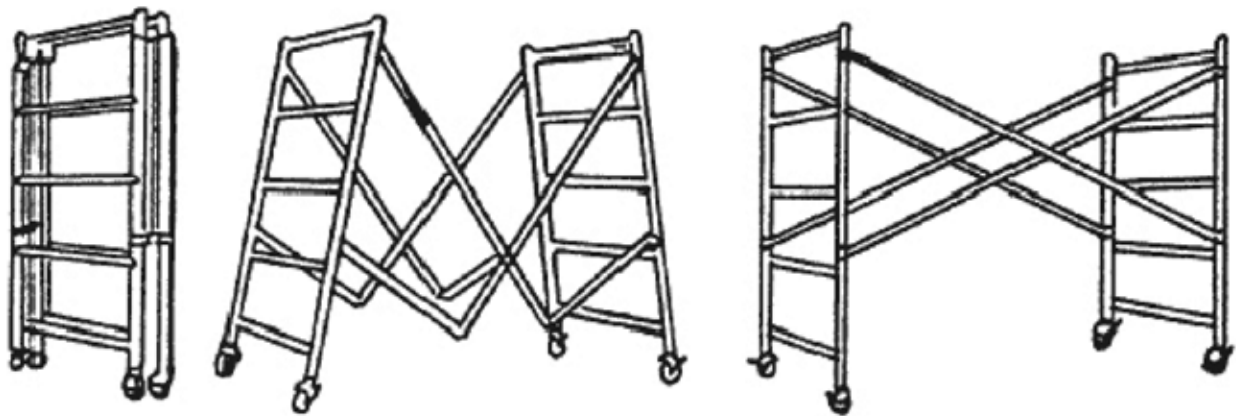

Adjustable Scaffolds (Baker Scaffold)

Though lightweight and easy to use, adjustable height platform scaffolds are different from foldup scaffolds. They have a minimum number of components, making them easy to transport from job to job. They must be used on smooth, hard surfaces only. They are not designed to carry heavy loads.

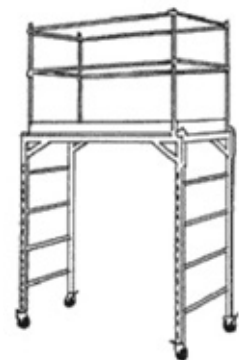

Tube-and-Clamp (Coupler) Scaffolds

Tube-and-clamp scaffolds are often used for work on non-rectangular, curved and irregularly shaped structures. They work well where there are obstructions because they are infinitely adjustable in height and width.



Right angle both clamps (couplers).

Note: Securing device must always be positioned on top of the horizontal tube.

Tube-and-clamp scaffolding differs from manufacturer to manufacturer, and workers using this type of scaffolding must refer to the manufacturer's instructions for erection, use and dismantling.

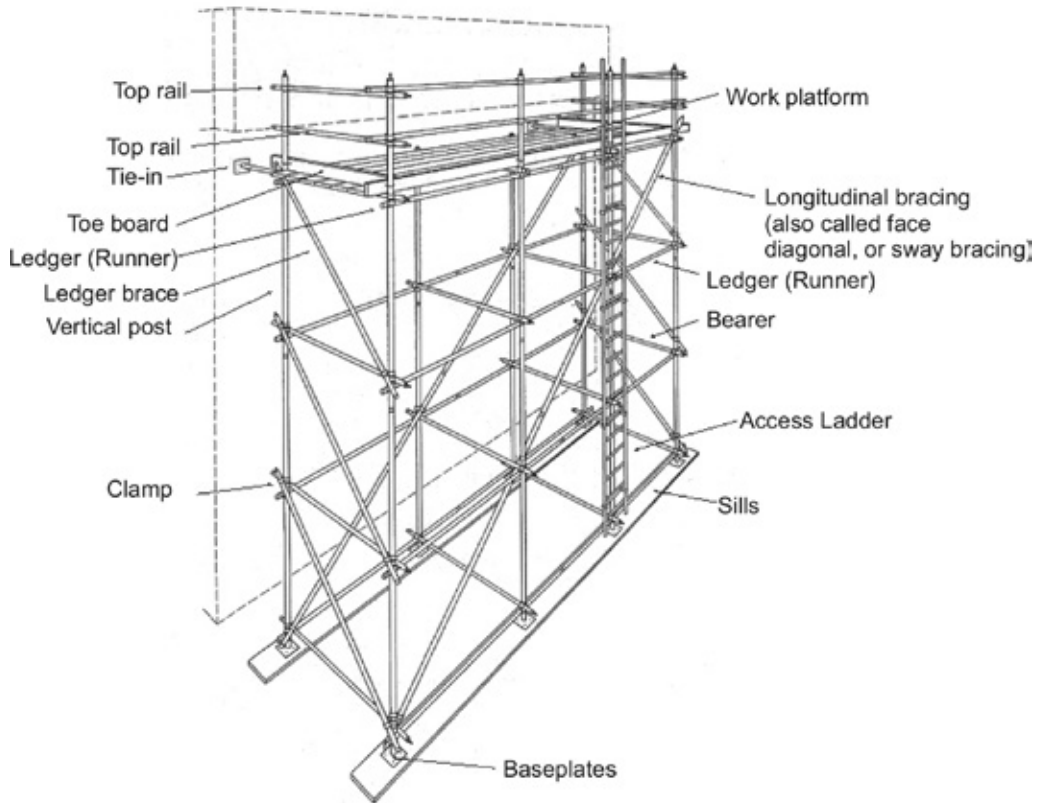

Single Pole Tube-and-Clamp Scaffolding

A single pole scaffold is a work platform supported by bearers attached at their outer ends to a row of braced vertical supports (posts) and securely fastened to the building or structure at their inner ends. It depends on the structure it is placed against for support.

The bearers are attached to the vertical posts using right angle clamps (couplers) and are securely fastened to the building or structure using tie-ins. Ledgers or runners are the horizontal spacing members that attach to the vertical posts and support the bearer. Ledgers must be clamped to every vertical post beneath the bearer.

A single pole scaffold must also be adequately supported by diagonal bracing on the outside of the posts at approximately a 45-degree angle with either swivel clamps or right-angle bolt clamps. The bracing is normally installed at the first bay and repeated every third or fourth bay thereafter. Bracing must not be more than 6 m (20 ft.) long and should be connected to the vertical supports as close to the ledgers as possible.

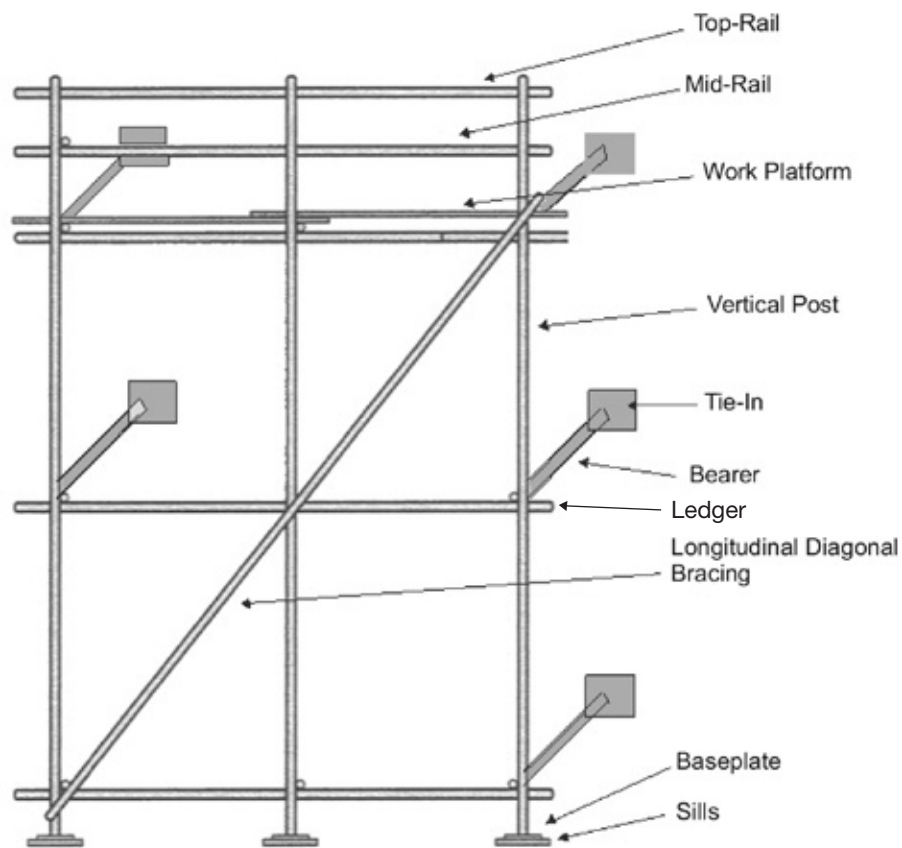

Single Pole - Tube & Clamp Scaffolding



SCAFFOLD FOUNDATION AND SUPPORT

Scaffolds must be installed on surfaces that can adequately support the loads they apply. To support scaffolds, the ground must be well-compacted and levelled. Mud and soft soil should be replaced with compacted gravel or crushed stone. Embankments that appear unstable or susceptible to erosion must be contained.

Scaffolds installed on any type of soil or gravel must be supported by a sill plate. Sills may be made from spruce, pine or fir (SPF) planks that are a minimum of 50 mm x 250 mm (2 in. x 10 in.). The sills (planks) must be continuous under at least two consecutive end frames or supports. A proper base plate is required under all circumstances. The base plate must rest centrally on the sill plate; the sill plate must project at least 305 mm (12 in.) beyond the scaffold foot ends.

The use of blocking or packing, such as bricks or short pieces of lumber or scrap material, under scaffold base plates or sills is prohibited.

Take particular care when erecting scaffolds on frozen ground. Thawing soil is often water-soaked, resulting in considerable loss of weight-bearing capacity. Thawing is an important consideration where tarps or other covers will be placed around a scaffold and the enclosed area is to be heated.

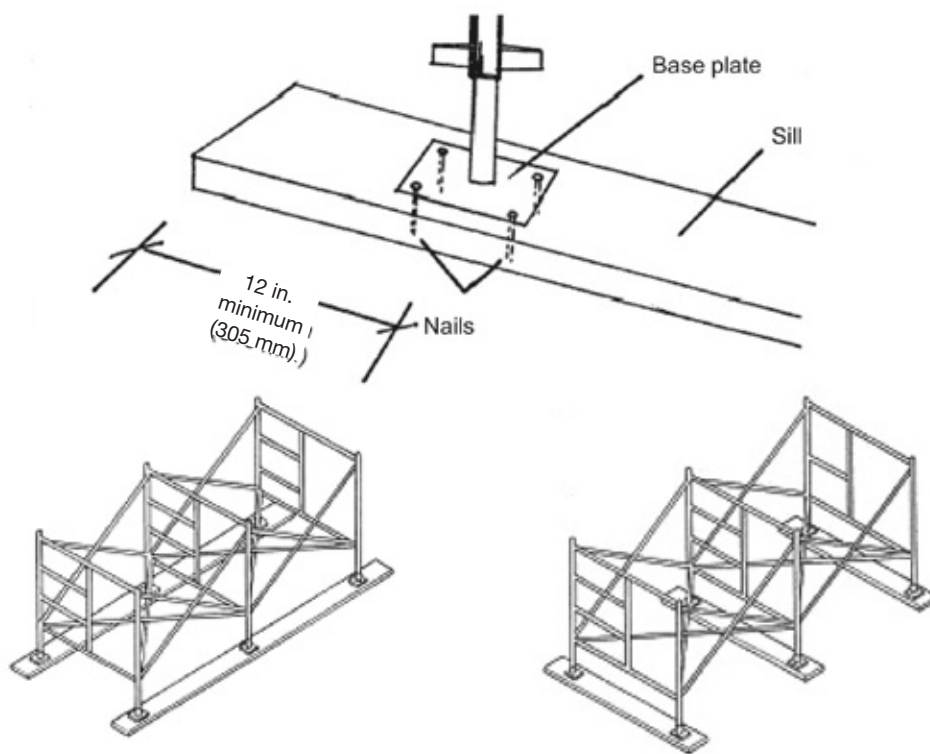

SCAFFOLD ERECTION AND BRACING

Fittings and Accessories

It is essential to install all the parts, fittings and accessories required for a scaffold so that it is installed according to the manufacturer's instructions. Ensure that all the components are in good condition and examine them to verify that they are not damaged. All fittings must be securely connected.

Base Plates and Screw Jacks

Base plates help distribute concentrated leg loads over a larger area. They also connect scaffold standards and sill plates. Base plates attach to scaffold legs with pins or locking devices. Workers erecting scaffolds often put screw jacks between the scaffold legs and base plates to allow the scaffold to be levelled. Base plates usually contain predrilled holes for attaching the plates to the sill plates.

Base plates must be used on all non-mobile scaffolding of a size and capacity specified by the manufacturer. Combination base plates with screw jacks must not be over extended; refer to manufacturer specifications.

Plumbing and Levelling

It is essential that the scaffold is installed plumb and level to ensure the maximum structural capability of the system. When the first tier of scaffolding is installed, check for plumb legs and level decks, and continue doing so as the scaffold is built.

Bracing

Bracing helps keep the scaffold frame plumb and square in both vertical and horizontal planes, and provides stability against lateral movement. Once the frames have been fitted with adjustable base plates, the braces must then be attached for each tower span. The braces should slide into place easily. If force is required, the braces are likely bent or damaged, or the frames are out of plumb or square.

Coupling Devices

Every scaffolding manufacturer provides coupling devices to join scaffold frames together in the vertical plane. Coupling devices must always be used and installed properly at every joint as assembly proceeds.

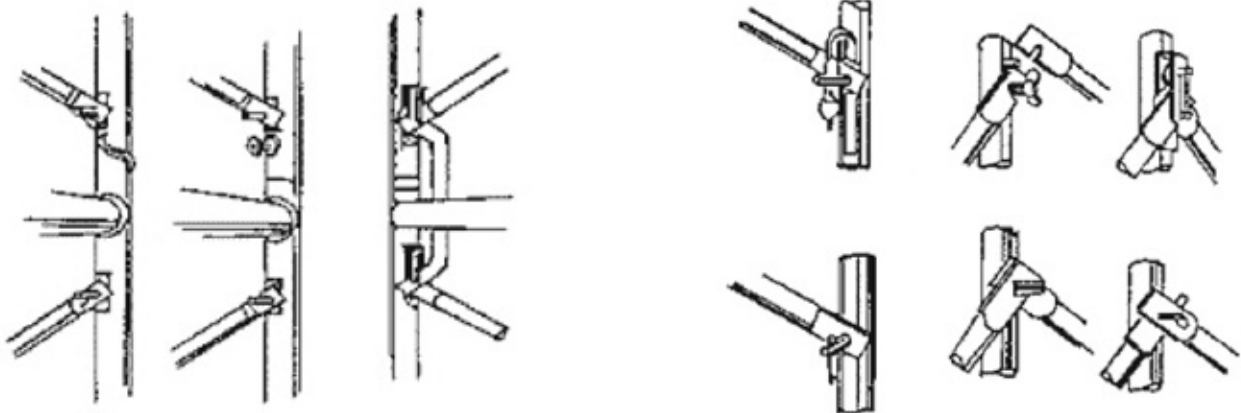

Wheels or Casters

If wheels or casters are used, they must be securely attached to the scaffold and equipped with brakes that are well maintained and easily applied. Make sure the ground is level and free of potholes and other obstructions where the scaffold will be located.



Hoisting Materials

Where scaffolds are more than 6 m (19.67 ft.) in height, they must be equipped with a suitable hoisting device. While materials can be pulled up by rope, it is easier to rig a pulley system to the scaffold so that hoisting can be done by workers on the ground. Ensure that you do not lift material in excess of the load capacity of the hoist system or scaffold connection or stand directly under the load while being hoisted.

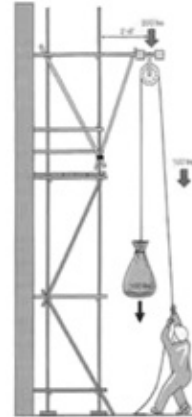

Dismantling

To dismantle a scaffold, reverse the installation procedure. Completely dismantle each tier and lower all material to the ground before proceeding with the tier below.

Workers must use a fall protection system that meets the requirements of Part 14 (Fall Protection) of the *Workplace Safety and Health Regulation*.

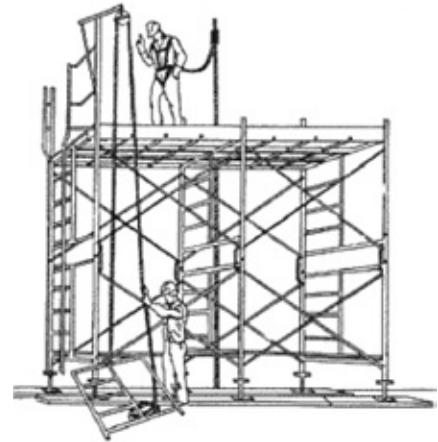

SCAFFOLD ACCESS

Fall Protection

If a scaffold platform is 3 m (9.84 ft.) or more above a surface that a worker might fall to, employers must ensure that the platform has a guardrail on the outer edges of all open sides and ends.

In most cases, a proper fall protection system can be put in place for workers installing and dismantling scaffolding. Often, the scaffold is being erected on the side of a building or structure. In these cases, a lifeline can be secured to a suitable anchor on the building and a fall arrest (rope grab) attachment to a full body harness will protect the worker installing the scaffolding.

Every worker on a suspended platform or boatswain's chair, must wear personal fall protection equipment, generally consisting of a safety harness and lanyard attached to:

- a moveable fall-arresting device on a lifeline that is secured to a separate roof anchor
- for aerial or elevated platforms, a manufacturer-approved anchor on the platform.

The lifeline must be secured to an anchor on the roof, as close as possible to the point of suspension of the equipment, and directly above the platform, to limit side-to-side swinging of the worker in the event of a fall.

Because lifelines often rest against roof edges or parapets, they must be protected from cutting. It is, therefore, recommended that pads be installed on the roof edges or that protective sheathing be used where the platform descends, which also serves to improve worker safety and extend the service life of the cables.

Each person on a work platform, or man basket suspended from a crane or hoist, should use a personal fall arrest system with a shock-absorbing lanyard secured to an anchor above the load hook.



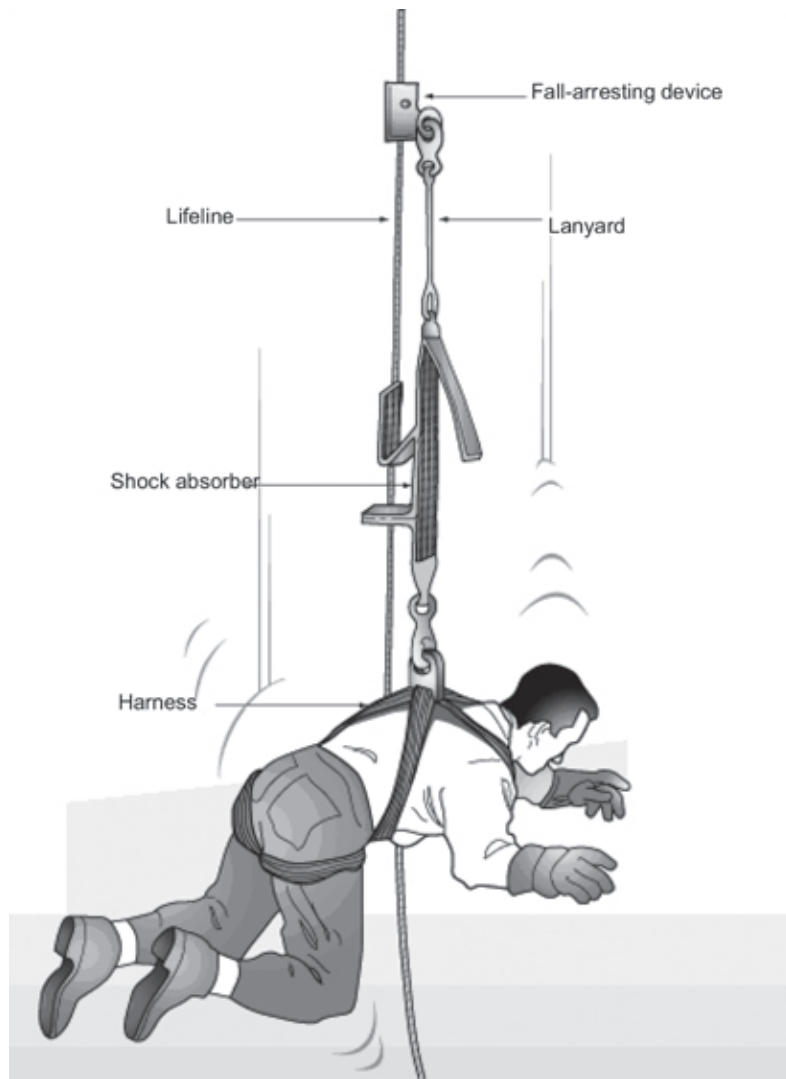

Shock Absorber

Ladders

If a scaffold is 9 m (29.53 ft.) or more in height, employers must ensure it is equipped with an internal stairway or ladders. If any ladder exceeds 3 m (9.84 ft.) in height, the ladder must be equipped with fall protection attachments.

There are four primary means of ladder access to a scaffold:

1. Climbing Frames (integral pre-fabricated access frames)

Only scaffolds with built-in ladders, designed and manufactured with rungs placed approximately at 12 in. centres may be climbed without a ladder. The alternative is to use a properly secured portable ladder or stairway.

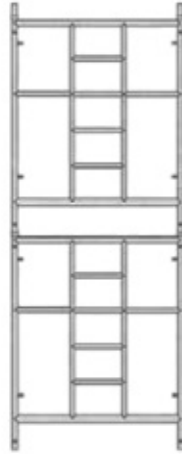

Stacked access frames

2. Portable Extension Ladders

Portable extension ladders may be used inside frames or on the exterior of a scaffold, but they must be secured at the top and bottom. The ladder must be set up in accordance with standard safe ladder practice. This means observing a 4:1 distance ratio from the structure and making sure ladder rails extend at least 1 m (3.28 ft.) above the highest point of access.



Extension ladder set against a scaffold



Staggered extension ladders:
front and end view



3. Stand-Off Vertical Ladders (Component Vertical Ladder)

Manufacturers make ladders designed to attach to scaffold frames or tubes using brackets. These ladder sections vary in length, but must also be restricted to 3 m in height, unless a proper ladder climbing fall protection system is provided. The scaffolding erector installs these ladders tier by tier, as the scaffold goes up. The ladders can be attached to the left, right or centre of the scaffold. For multiple tiers, this allows staggering of the ladders between rest platforms.

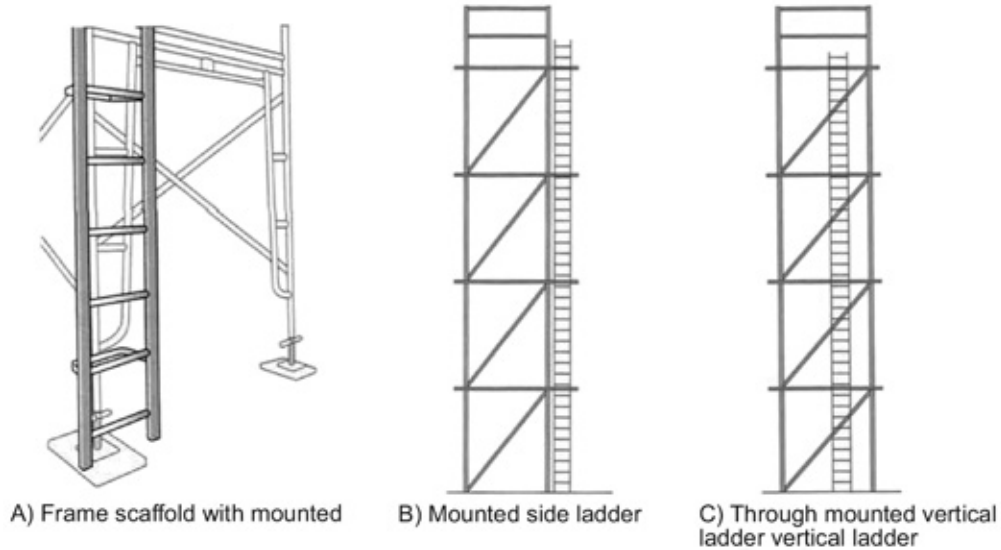

4. Scaffold Stairway Systems

The best method for scaffold access is a stairway built into the scaffold structure. This provides for complete fall protection and includes built-in rest platforms. Rest platforms should be built so that material cannot fall from one landing to the next.

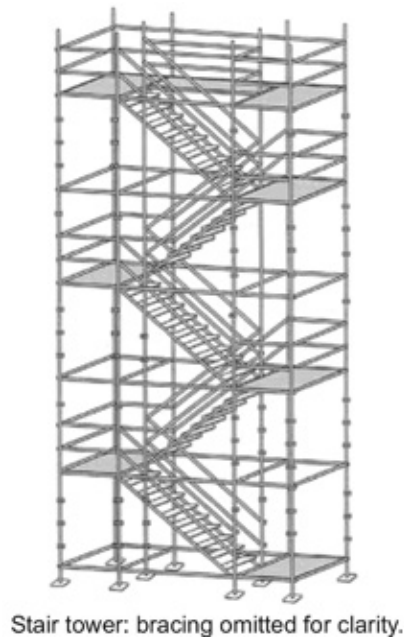

SCAFFOLD WORK PLATFORMS

The choice of a scaffold platform depends on the type of work being done. Before platform material is selected, determine the weight of workers, tools and materials to be supported by the decking.

When a scaffold platform consists of wood planks, an employer must ensure that each individual plank is secured to prevent lateral movement. If there is a possibility of upward force on the planks (e.g., wind load), the planks must be secured against movement. Vertical supports for the planks must be provided at least every 2.5 m (8.20 ft.).

An employer must ensure that a scaffold platform is secured to prevent movement and is at least 500 mm wide nominally. Where a scaffold platform forms part of a lean-to scaffold and consists of a commercially manufactured plank, the platform must be at least 400 mm (15.72 in.) wide.

Scaffold planks must extend at least 150 mm (5.91 in.), but not more than 300 mm (11.81 in.), beyond the end supports of the scaffold. If the planks overlap, the overlap must be centred directly over a vertical support of the scaffold, and the overlapping planks must extend at least 300 mm (11.81 in.) beyond the end supports of a scaffold.

Work platforms shall only be located on the top and bottom of frames, not across their intermediate braces.

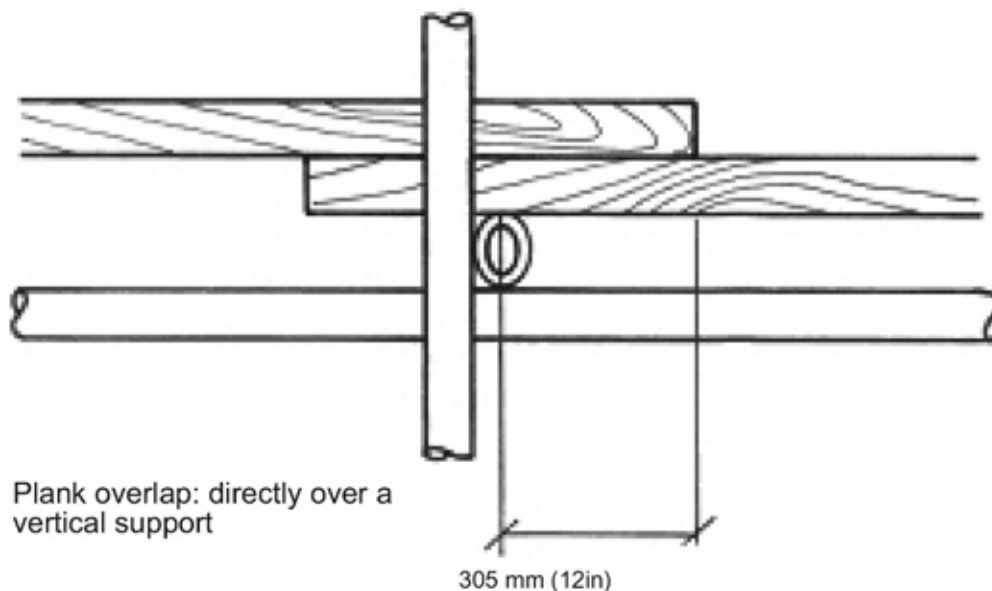

Aluminum/Plywood Platform Panels

These platforms are pre-manufactured wood and aluminum decking with special fastening hardware. The manufacturer normally determines the load-carrying capacity and marks it on the platforms. Platform hooks and fastening hardware must be checked regularly for looseness, cracking and distortion.



Laminated Veneer Lumber

This material is a special type of exterior plywood rated by the manufacturer for scaffold use. The material is manufactured in large sheets of various thicknesses, which can be cut to the required size for different uses.

The planks must be inspected routinely. Planks showing de-lamination, fungi or blisters must be removed from service.

Sawn Lumber Planks

Sawn lumber planks, 50 mm x 250 mm (2 in. x 10 in.) or larger, have been the standard scaffold platform material for many years. Planks must meet or exceed the requirements for No.1 construction grade of the species group used, which should be either spruce-pine-fir (SPF) or Douglas fir.

Sawn lumber planks must be 5 m (16.40 ft.) or less in length and have the same thickness as the adjoining planks. They must be laid tightly together side-by-side with adjoining planks to cover the full width of the scaffold platform.

Since wood planks deteriorate, they must be inspected on a regular basis and removed from service if inadequate. A jump test is **not** an acceptable method of inspection. Such methods can overstress the planks and cause undetectable damage.

Sawn Lumber Plank Inspection Criteria

Scaffold planks must be examined before use on a scaffold and at regular intervals to ensure that the planks remain in safe condition.

- **Planks** – Wood planks must be SPF No. 1 construction grade lumber or better, nominal size 50 mm x 250 mm (2 in. x 10 in.). They must be properly seasoned and free from bows, crooks, cupping or twisting.
- **Splits** – Planks with splits wider than 10 mm (3/8 in.), or lengthwise splits closer than 75 mm (3 in.), to the edge of the plank, must be removed from service. When a lengthwise split in a plank exceeds half the length of the plank, then that plank must also be removed from service.

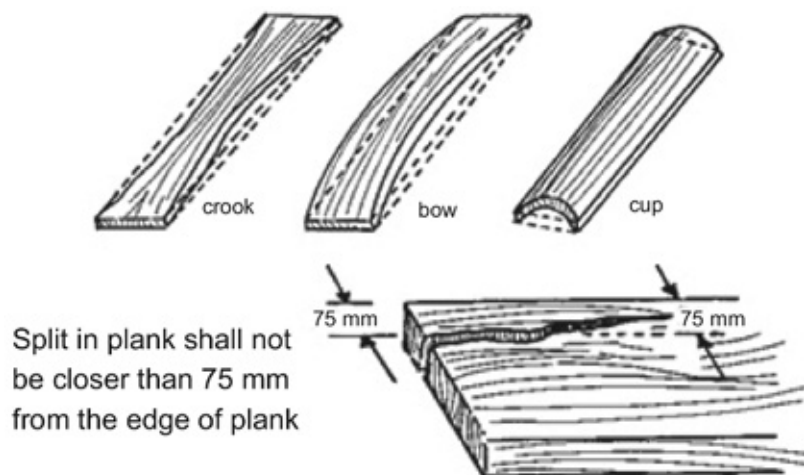

- **Plywood Cleats** – Plywood cleats must not be used along the length of the plank to keep planks from splitting. Cleats may accumulate and retain moisture where they are fastened, rotting the plank. Inspect any scaffold planks with cleats and remove them from service if there is any indication of wood rot. Proper end cleats must still be used to prevent planks from sliding off the scaffold frame.

Do not use plywood cleats



- **Wood Grain** – The grain is not to exceed a slope of 1 in 12 along the length of the plank.

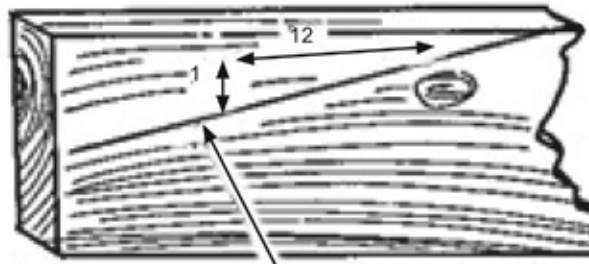

slope of grain

- **Knots** – Knots must be sound, tight and spaced well apart. Maximum knot size for a 50 mm x 250 mm (2 in. x 10 in.) plank is 50 mm (2 in.) in diameter.

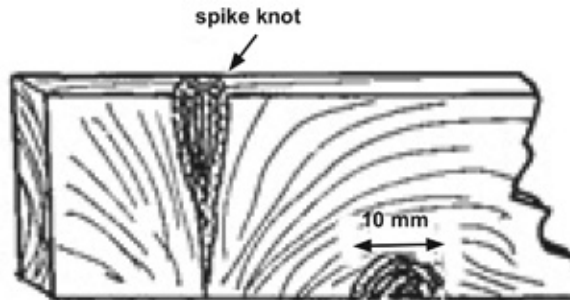

Impermissible knot at edge

Knots on the edge of a plank must not be greater than 10 mm (3/8 in.) wide or extend across the entire width.

- **Dry Rot** – Scaffold planks can also be weakened by dry rot. This condition is not easily recognized in its early stages, especially if the exterior of the planks is weathered. Planks substantially infected with dry rot are usually lighter than normal and must **not** be used.



GUARDRAILS

In Manitoba, on scaffolds where the platforms are 3 m (9.84 ft.) or more in height, open ends must have guardrails in line with the outer edges of the platform.

Manufacturers of standard scaffolds have guardrail components that can be attached to the scaffold frames. Where these are not available, guardrails can be constructed from lumber or tube-and-clamp components.

Guardrails must be constructed to resist a force of at least 900 N (200 lb.) applied anywhere on the guardrail.

The top rail of a guardrail must be installed at least 900 mm (35.4 in.) high and not more than 1,060 mm (41.6 in.) above the working surface, with an intermediate rail installed between 450 (17.7 in.) and 530 mm (20.8 in.) above the working surface. The mid rail must have the same design capacity as the top rail.

Toe boards must be provided where there is a possibility of materials falling from one working level to another. The toe boards must extend a minimum of 125 mm (4.92 in.) high.

The vertical wooden posts may be attached to the frame legs using U-clips secured with 5/8 in. (1.9 cm) rope.

Vertical cross bracing is not considered a guardrail and must not be used in such a manner.

Tube-and-clamp guardrails may be constructed from standard aluminum scaffold tubing using parallel clamps to attach the vertical posts to each frame leg. Top rails and mid rails must be attached to the vertical posts.

SCAFFOLD STABILITY

Three-to-One Rule

The ratio of unsupported height to least lateral dimension on a scaffold must not exceed 3-to-1, unless the scaffold is:

- tied to the structure at proper horizontal and vertical intervals
- equipped with outrigger stabilizers to maintain the ratio of 3 to 1
- equipped with anchored tie backs specified by a manufacturer or professional engineer.

The 3-to-1 rule applies only to the extent that outriggers are extended symmetrically about the scaffold base.

Outrigger Stabilizers

Outriggers or stabilizers are used to provide base stability and maintain the 3-to-1 rule. The outriggers or stabilizers must be adequately attached to the scaffold base. On soil, the outrigger feet should always be placed on SPF planks.

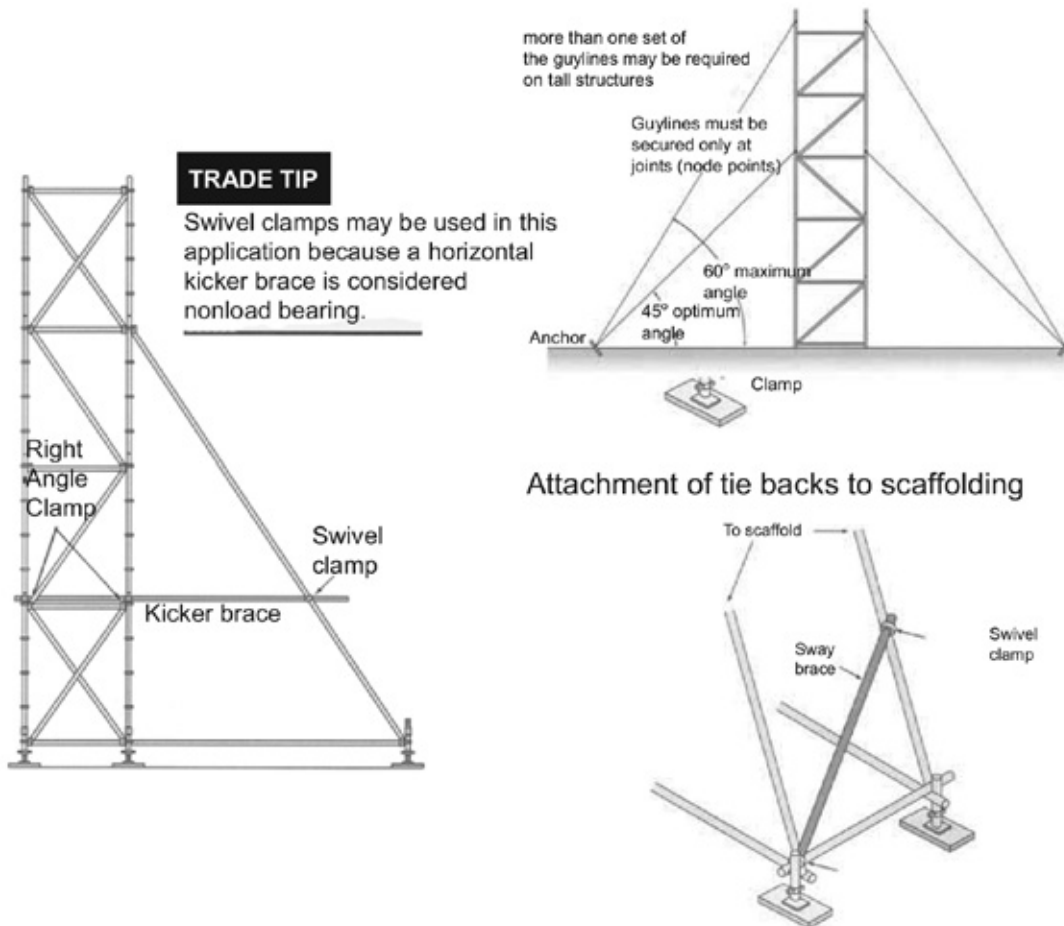

Where stabilizers are used with casters, the casters must rest firmly on a solid surface with the stabilizer secured in the extended position before workers use the platform.



Characteristics: Rope, Wire Rope and Tiebacks

Employers must ensure that ropes or wire ropes used in scaffolding are protected against abrasion or other physical damage and made of heat or chemical-resistant material if there is a possibility of exposure to heat or chemicals.

In Manitoba, an employer must ensure that #9 wire is not used in a tie-in system for securing a scaffold to a building or structure.

Tie-in systems must be designed by a professional engineer where open scaffolding exceeds 10 m (33 ft.) or enclosed or hoarded scaffolding exceeds 7.5 m (25 ft.).

The tie backs must sustain anticipated wind loads or dynamic loads caused by work being done on the scaffold. Tie-in design loads must be increased where heavy loads such as pallets of masonry materials will be placed on the scaffold. Enclosed or hoarded scaffolding requires more tie backs to the building structure because it endures heavier wind loading.

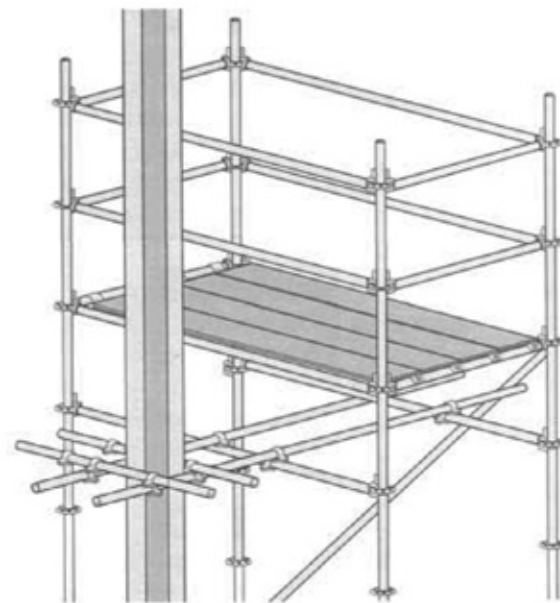
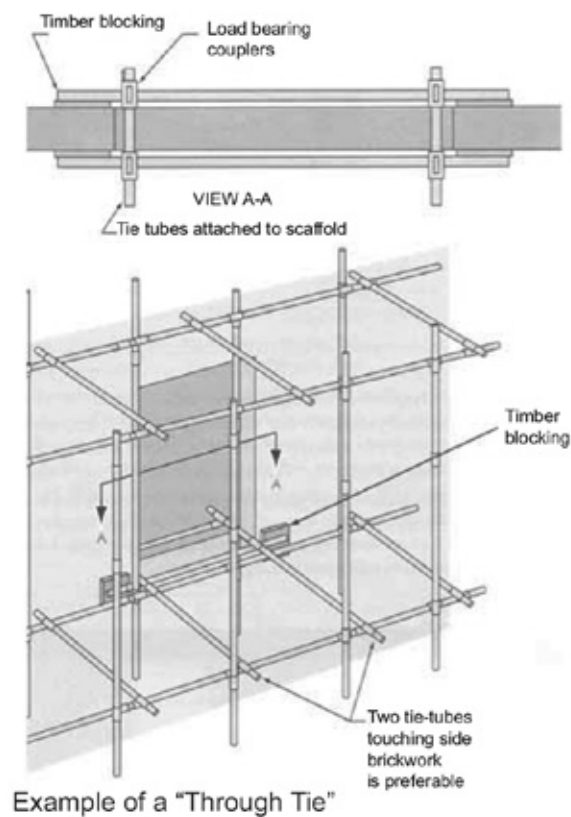

Example of a "Box Tie"

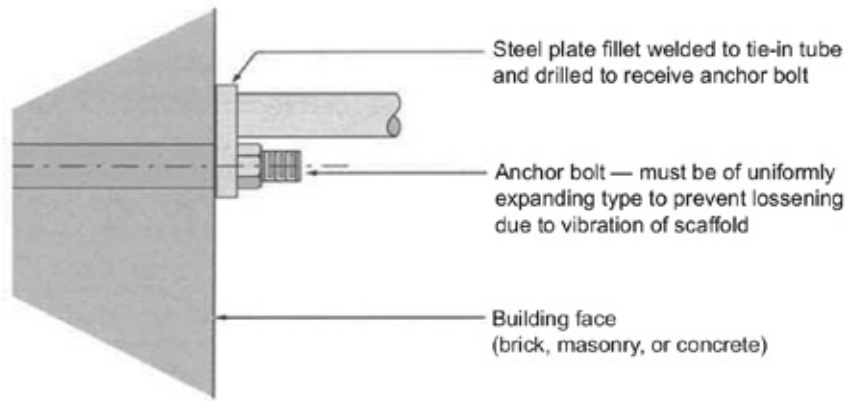

Example of an "Anchor Bolt Tie-in"

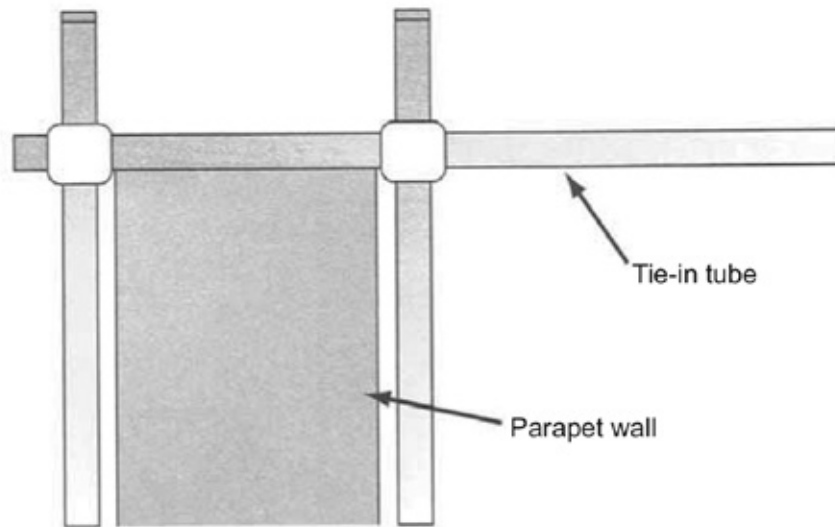

Example of "Lip Ties"



Covers

Some scaffolds are covered (hoarding) with tarps or other materials to enclose them against weather or to contain dust for operations like sandblasting. Scaffolds greater than 7.5 m in height must be designed by a professional engineer. Wind speeds, structure shapes and other variables can affect the design and erection of all covered scaffolding greater than 7.5 m (25 ft.) in height.

Where scaffolding is completely covered, adequate ventilation must be provided to ensure worker protection when heating, sandblasting or other procedures expose the worker to hazardous materials or agents.

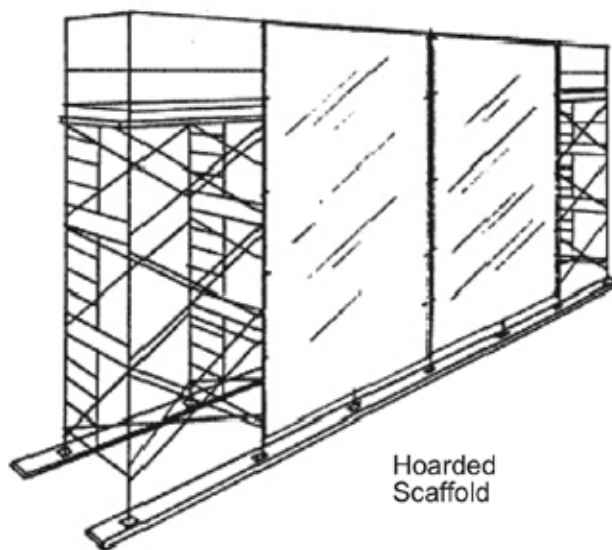

Wind Uplift

Wind can lift lighter platform materials from the scaffold if they are not secured. Where severe wind conditions are anticipated or where high scaffolds are involved, platform materials such as aluminum/plywood panels should be secured to the scaffold. Some platform panels are secured with wires or nails. Some pre-manufactured systems incorporate locking devices.

SCAFFOLDING USE AND MAINTENANCE

Before erecting a scaffold, check the location for:

- ground conditions
- overhead electrical wires
- obstructions
- variation in surface elevation
- tie-back locations and methods
- potential wind-loading conditions.

Typical Loads and Requirements

The intended load must always be considered when a platform is installed. To reduce the impact of point loading, all workers, including erectors, should always try to distribute loads uniformly on the scaffold, as shown below.

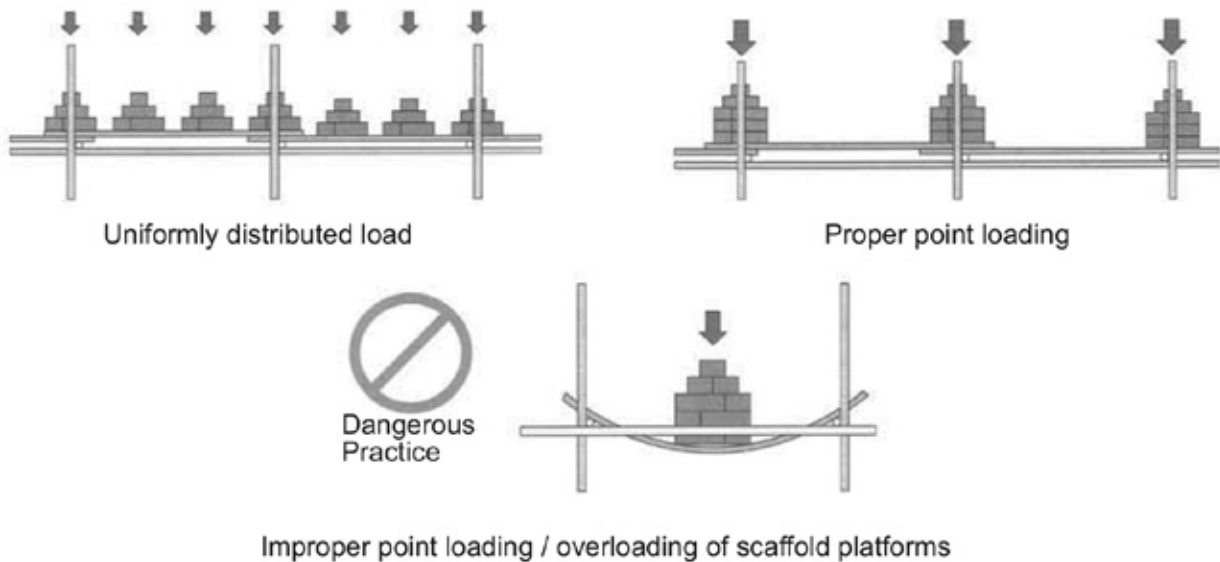

Double planking on decks may be necessary where pallets of masonry materials are to be supported. Wherever possible, the pallets should be placed over the frame supports. In addition, planks used to support masonry materials must be inspected for damage or deterioration regularly.

Overloading may affect stability as well as load-carrying capacity. Differential settlement is often a problem where heavy loads are applied to scaffolds resting on loose or porous ground. Heavy loads should be placed symmetrically on the platform to ensure that soil settlement is uniform.

The scaffold structure must be able to carry intended loads. Both light-duty and heavy-duty frames are available on the market. If their load-carrying capacity is not known, consult the manufacturer or supplier and obtain the information before using frames. Be aware that the load-carrying capacity of scaffolding frames can vary with the height of the towers.



Housekeeping

Scaffold decks are usually small, narrow and confined. Tools and materials to be used should be stored in an orderly fashion. Debris and waste materials should not be allowed to collect on the platform. They should either be put in a container or removed from the platform immediately. Waste pieces of lumber, pipe, wire and miscellaneous metal and small tools are tripping hazards that have caused many falls from scaffolds. Working safely on scaffolds requires keeping an orderly work area.

Inspection

The employer must ensure that all scaffolding systems are inspected:

- prior to workers using them
- during periods of severe weather conditions.

The scaffold system must be inspected on a regular schedule and a record of the inspections maintained at the job site.

Some of the things to look for include:

- damage to frames, braces and other structural components
- damage to hooks on manufactured platforms
- splits, knots and dry rot in planks
- de-lamination in laminated veneer lumber planks
- compatibility of components
- sufficient and proper components for the job
- scaffolding that has been in place for a long time.

Structural components that are bent, damaged or severely rusted must not be used. Similarly, platforms with damaged hooks must not be used. Planks showing damage must be discarded and removed from the site so they cannot be used as platform material.

Scaffold Inspection Checklist

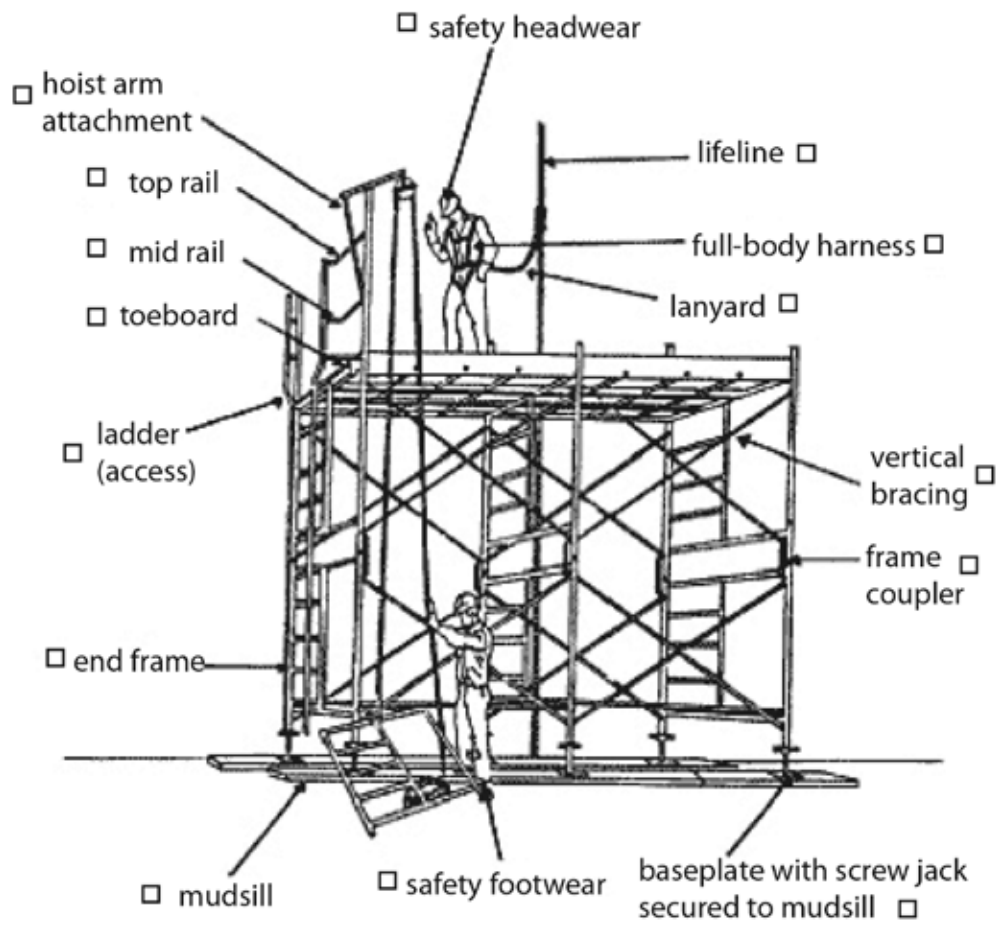

SUSPENDED SCAFFOLDS

A suspended scaffold is one or more platforms suspended from an overhead structure(s) by ropes or other non-rigid means. This type of scaffold is for temporary use only in situations where workers need access to vertical sides of structures.

Every employer is required to notify the Workplace Safety and Health Branch at least eight hours before rigging a suspended work platform in excess of 3 m (9.84 ft.) in height. A copy of the suspended work platform notification form appears in **Appendix B** of this guideline.

Suspended equipment shall not be used in conditions of high winds, inclement weather or extreme temperatures where such conditions impair safe use of the equipment. Suspended equipment must be tied back to an approved anchor.

Signs containing the warning, **Danger – Do Not Enter**, in clear, legible letters should be posted in prominent locations and in sufficient numbers to warn others, including pedestrians, that suspended equipment operations are being conducted overhead. Swing stage equipment should also be used in conjunction with walk-through scaffolding for pedestrian protection.

People working on a surface where they may fall onto a hazardous substance or object, or at a height of 3 m (9.84 ft.) or more above the ground, must use a fall protection system meeting the requirements of *Workplace Safety and Health Regulation M.R. 217/2006*, Part 14.

Suspension ropes or wires must be in line with the point of suspension for their entire length unless the suspension system is designed specifically for angled line work. Suitable padding or protection must be provided, where necessary, to protect wires and ropes from abrasion or cutting.

Each suspended scaffold and scaffold component must be capable of supporting its own weight and at least four times the maximum weight that will be applied to it. Each suspension rope and its connecting hardware must be capable of supporting at least 10 times the rated load.

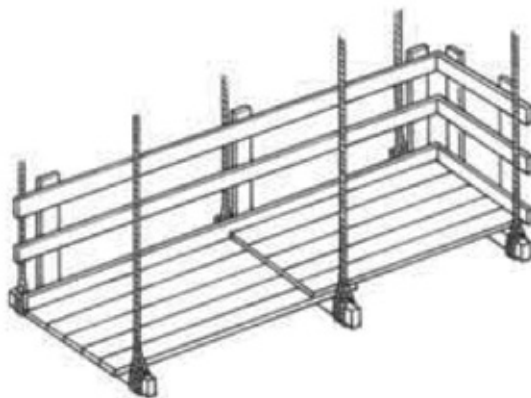

Example of an interior hung suspended scaffolding.
Illustration shows scaffolding hung below 3 metres.
Scaffolding hung above 3 metres must have guardrails on all sides.

Safe work procedures (example: see Appendix A) must be developed and applied by the employer for every project where suspended equipment will be used.

The safe work procedure should describe intended work methods and necessary rigging procedures according to the roof plan certified by a professional engineer, as required by the CSA Standard Z91, *Health and Safety Code for Suspended Equipment Operations*. The safe work procedure must include, but not be limited to:

- the name, address and telephone number of the building owner or contact person
- the name, address and telephone number of the work site supervisor
- a general description of the work
- approved anchor locations
- the procedure for fall protection
- the procedure for equipment rigging and use of the manufacturer's operating and maintenance manual, including but not limited to, permanent and portable equipment rigging plans
- available means of communication
- emergency contact names and phone numbers
- emergency procedures, including but not limited to:
 - worker injury
 - equipment damage/failure
 - provisions for self rescue
 - an emergency response plan

Criteria for Suspension Scaffolds

All suspension scaffold support devices must be commercially manufactured or designed by a professional engineer. They must rest on surfaces that can support at least four times the load imposed by the scaffold operating at the rated load of the hoist, or at least 1.5 times the stall capacity of the hoist, whichever is greater. Scaffold support devices include outrigger beams, cornice hooks, parapet clamps and similar devices. Suspension scaffold outrigger beams must be made of structural metal or equivalent strength material and must be restrained to prevent movement. Before rigging a support system using a parapet, wall or other part of a building, the placement must be verified and documented by a professional engineer as being structurally adequate to support the suspension system loads.

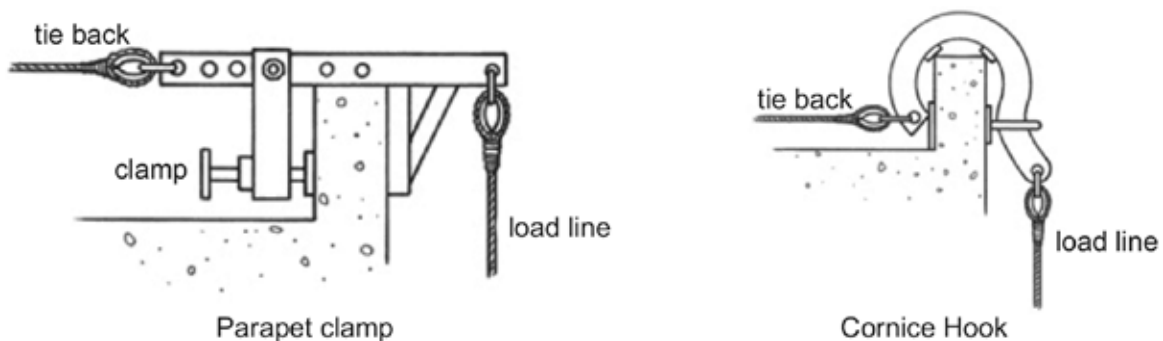

Outrigger beams must be located plumb to the stirrups of the platform and project at right angles, or as close as possible to right angles from the face of the building or structure. The outboard portion of the beam may not extend more than 1 m (3.28 ft.) beyond its fulcrum point. Beams must be labelled to indicate maximum capacity.



When counterweights are used, the length of the inboard portion of the beam or support structure must not be less than three times the outboard portion. Counterweighted systems must be labelled to indicate counterweight requirements. The weight of each counterweight used must be permanently marked on the body of the counterweight. The counterweights must be secured to the outrigger beams or support structure to prevent accidental displacement. Counterweights **must not be made of bagged or loose material** and must not be removed from an outrigger beam until the scaffold is disassembled.

The inboard ends must be stabilized with counterweights. The exceptions are masons' multi-point, adjustable, suspension scaffold outrigger beams, which must not be stabilized by counterweights. Tie-backs must be used to secure outrigger beams that cannot be anchored by bolts or other direct connections to the floor or roof deck.

Before the scaffold is used, confirm that the supporting surfaces are capable of supporting the loads to be imposed. If the structure being used to anchor the scaffold does not have existing anchor points, then anchor points must be designed by a professional engineer.

Support devices such as cornice hooks, roof hooks, roof irons, parapet clamps or similar devices must be made of steel, wrought iron or materials of equivalent strength. They must be supported by bearing blocks and secured against movement by tie-backs installed at right angles or near as possible to the face of the building or structure. Sound points of anchorage include structural members, but do not include standpipes, vents, other piping systems or electrical conduits.

In addition to the normal operating brake, suspension scaffold power-operated hoists and manually operated hoists must have a braking device or locking pawl that engages when the hoist exceeds normal descent speed (makes either an instantaneous change in momentum or an accelerated over-speed). Manually operated hoists require a positive crank force to descend. At least four wraps of suspension rope must be maintained at the lowest point of scaffold travel when winding drum hoists are used. When other types of hoists are used, the suspension ropes must be long enough to allow the scaffold to descend completely without the rope end passing through the hoist, or the rope end must be designed so that it cannot pass through the hoist.

Ropes supporting adjustable suspension scaffolds must be of the correct diameter to provide sufficient surface area for brake and hoist mechanisms to function properly. Wire suspension rope may only be connected to a support device by eye splice thimbles connected with shackles or cover plates and bolts.

See Part 28 of the *WSH Regulation* for a list of general requirements for suspending scaffolding.



Single-Point Adjustable (Boatswain's Chairs)

A single-point adjustable suspension scaffold (boatswain's chair) is a suspension scaffold consisting of a platform suspended by one rope from an overhead support and equipped with means to permit the movement of the platform to desired work levels.



Boatswain Chair
Powered



Boatswain Chair
Manual

A boatswain's chair raised and lowered by manually powered hoisting equipment, or used with a **descent only** rigging arrangement, must be designed to support the maximum intended load.

A powered (motorized) boatswain's chair is a powered platform and must meet the requirements of CSA Standard CAN/CSA Standard Z271, *Safety Code for Suspended Powered Platforms*.



Two-Point Adjustable (Swing Stage)

A two-point suspension scaffold (swing stage) is a suspension scaffold consisting of a platform supported by hangers (stirrups) suspended by two wire ropes from overhead supports and equipped with means to permit the raising and lowering of the platform to desired work levels.

If a swing stage scaffold has been designed by a professional engineer rather than manufactured commercially, specifications certified by a professional engineer must be developed.

When a suspended work platform is permanently installed on a building or structure, a professional engineer must certify, before its first use and annually, that the anchor points, platform and platform's suspension system are safe.

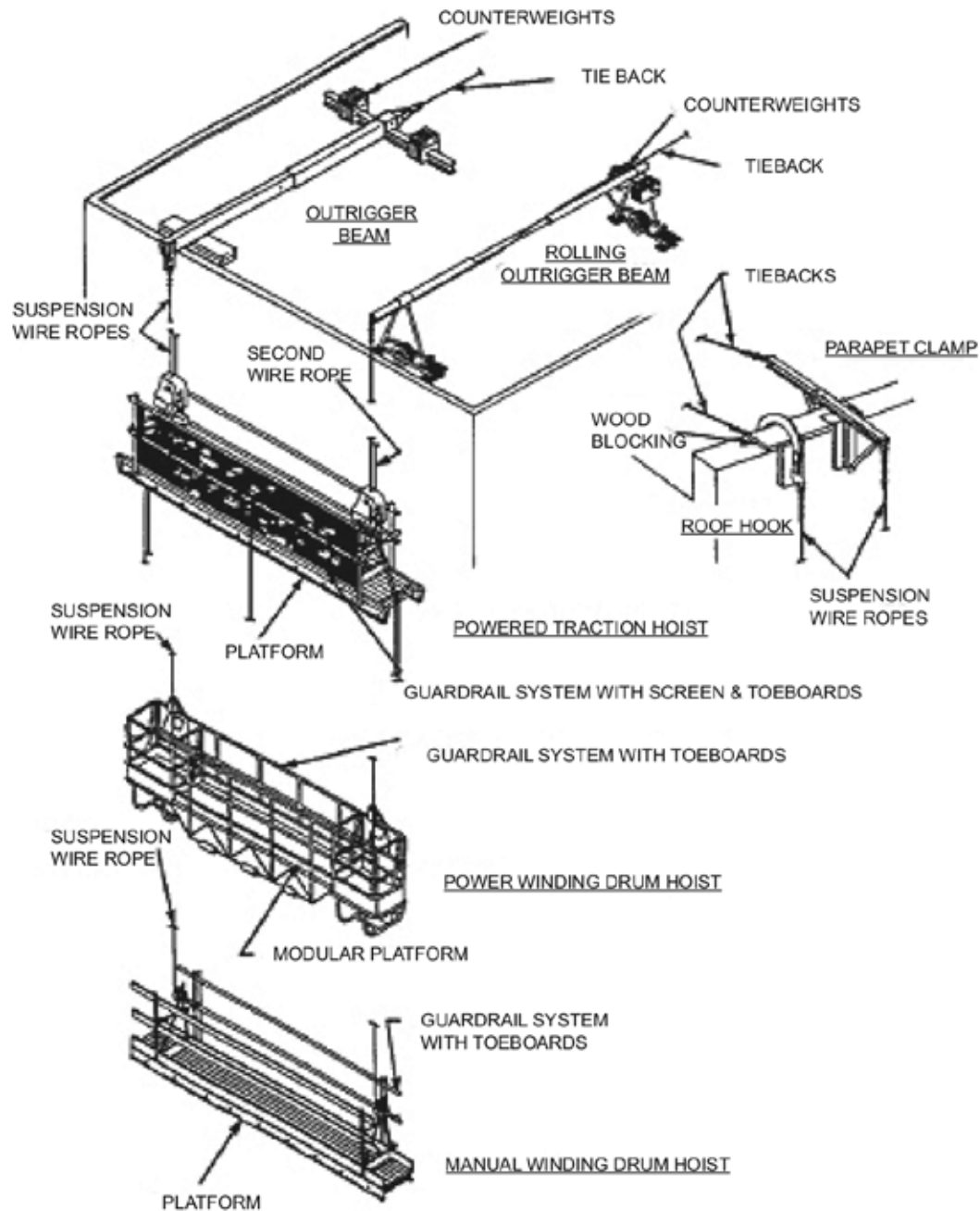

1. Work Platform (Stage)

The swing stage platform must be equipped with secure top rails, mid-rails, toe boards and properly sized stirrups. A swing stage has a specific capacity that is usually indicated on the stage itself. This capacity must not be exceeded. Should it be necessary to carry additional materials (besides personal tools), the user must ensure the stage is rated to carry the additional load.

All structural components must be securely fastened together according to the manufacturer's specifications. Properly sized and graded bolts and pins must be used to secure components together.

The floor boards may be metal or wood, and must be securely attached to the stage.

2. Suspension System

Proper swing stage suspension is critical to safe operation of the work platform. It includes the following:

1. Thrust-outs (Outrigger Beams)

The use of portable thrust-outs is one method of swing stage suspension. Usually, thrust-outs are two hollow structural steel sections that slide into each other and are held together with a pin and keeper. There must be a means to ensure the pin cannot become dislodged and fall out. The beam must be rated and rigged to withstand four times the maximum load applied. Beams should be used only according to the manufacturer's or supplier's tables of counterweights and projections allowed beyond the fulcrum point for various loads.

The spacing of the thrust-outs must be equal to the spacing of the hook-up points (stirrups) on the swing stage.

2. Counterweight Determination

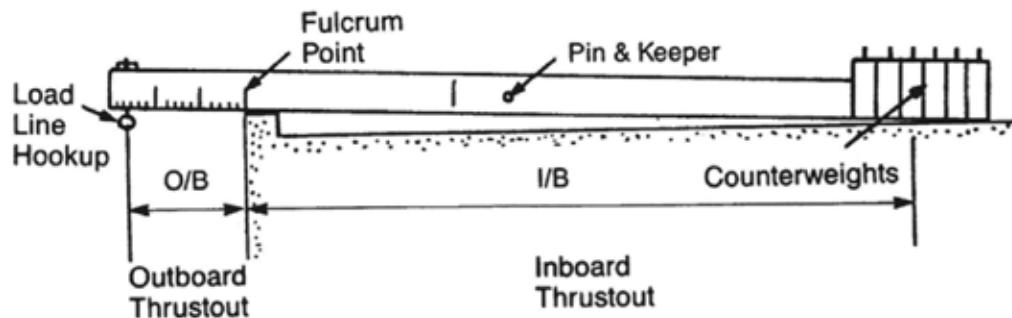

The formula for determining the required counterweight for each thrust-out is as follows:

Required Safety O/B Distance Counterweight = Factor x Load x I/B Distance



Example: A 9.75 m (32 ft.) swing stage with a safe working load of 230 kg (500 lb.) is suspended by two 4.88 m (16 ft.) thrust-outs that are overhanging 460 mm (1.51 ft.) from the fulcrum point.

i. Loads:

a. Live Load

Two men and equipment are 230 kg (500 lb.). Assume worst condition; load supported at one end of stage.

b. Dead Load

32 ft. swing stage is 318 kg (700 lb.) (includes motors, cables, etc.) supported equally by each thrust-out.

ii. Counterweights are 23 kg (50 lb.) each.

iii. In board is 4.42 m (14.5 ft.); outboard is 460 mm (1.5 ft.).

iv. The safety factor used for a swing stage is 4:1.

Calculation

The maximum load per thrust-out is $(500 + 700/2) = 850$ lb. (385 kg).

The maximum load that may be imposed on each thrust-out is calculated by determining the weight of the workers' tools, materials, suspension lines, hoists and the weight of the stage.

Using the formula:

$$4 \times (500 + 700/2) \times 1.5/14.5 = 160 \text{ kg (350 lb.)}$$

$$\text{S.F.} \times \text{Load per Thrust-out} \times \text{O/B/I/B} = \text{Total Counterweight}$$

If each counterweight is 23 kg (50 lb.), then each thrust-out needs:
(160 kg (350 lb.))

$$(23 \text{ kg (50 lb.)}) = 7 \text{ Counterweights}$$

3. Securing of Counterweights

Counterweights range in weight from 23 to 34 kg (50 to 75 lb.). The counterweights must be secured to the thrust-out by inserting a locking bolt, located on the counterweight, into a slot on the thrust-out.

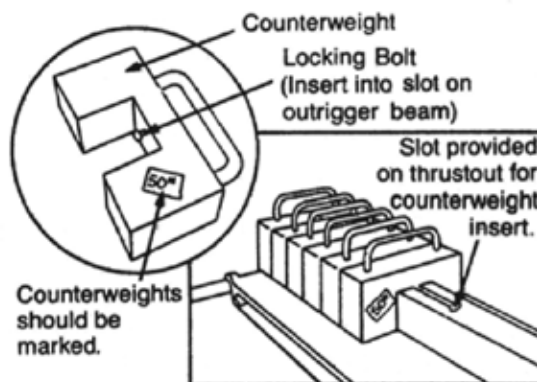

If there are more counterweights required than can be secured to the outrigger beam properly, then a T-beam thrust-out or other means of positive attachment must be used.

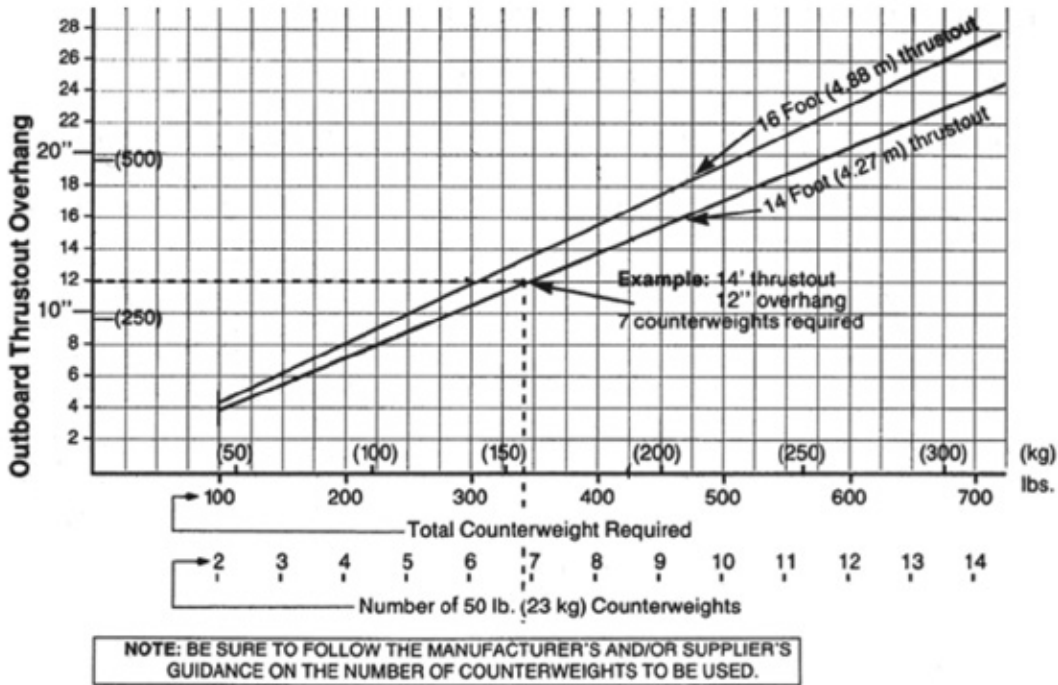
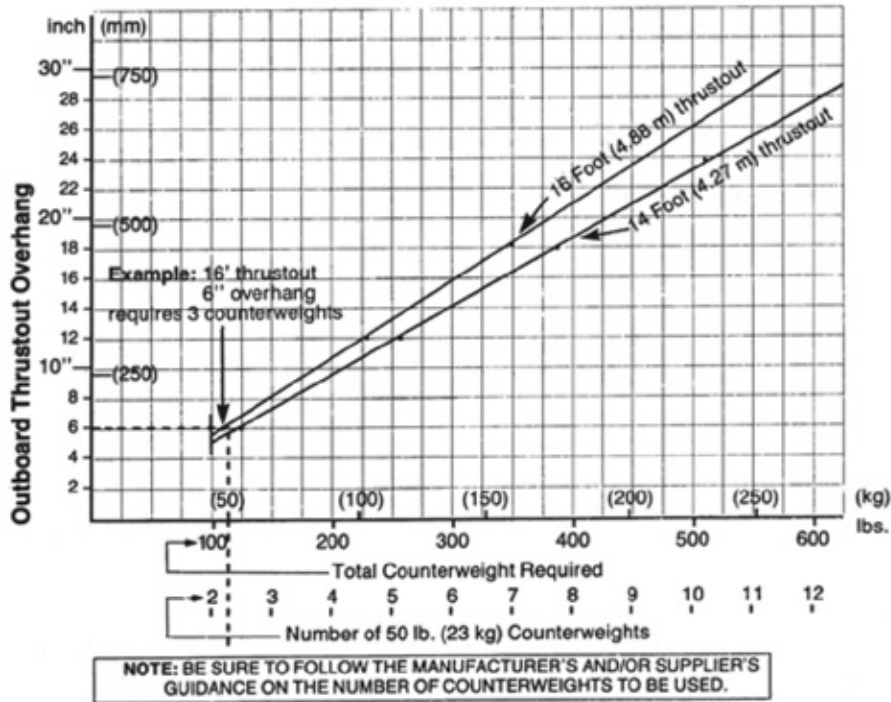

4. Thrust-out Overhang

The outboard thrust-out must not extend more than 1 m (3.28 ft.). If the thrust-out exceeds 900 mm (2.95 ft.), the thrust-outs need to be reinforced according to a professional engineer's specifications.

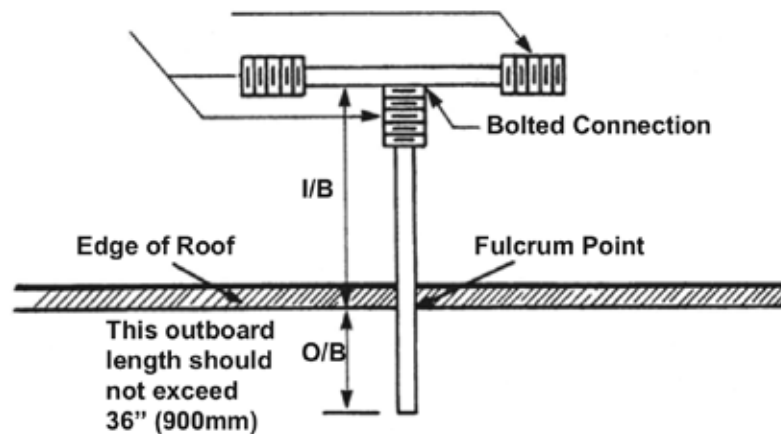

Thrust-outs should be marked to indicate the length of outboard overhang. The maximum allowable length of overhang should be clearly indicated on the thrust-out.

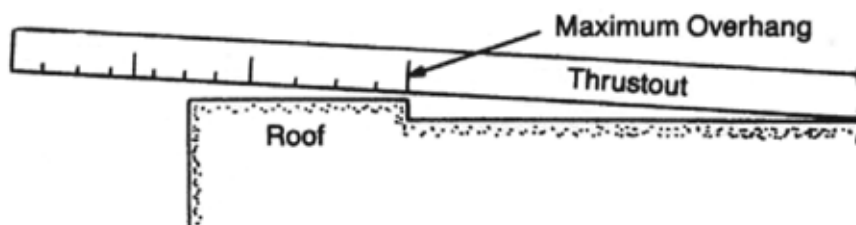

Whenever possible, the thrust-outs should be **placed at right angles** to the edge of the roof. If a thrust-out cannot be physically located at a right angle to the edge of the roof, then the length of the outboard section must still be taken along the centerline of the beam. If a thrust-out is angled, the outboard length must be kept as short as possible.

5. Thrust-out Tie-Backs

Tie-backs are used on outrigger beams to prevent movement of the beams and as a secondary means of support for the swing stage.

Tie-backs must consist of wire rope of equal strength to the suspension rope for the swing stage. The tie-back must extend from the thimble of the suspension line, along the outrigger beam, through the counterweight handles and back to the anchorage point. The anchorage point may consist of:

- roof structures (e.g., mechanical rooms, large HVAC units, etc.)
- properly designed roof anchorage systems as certified by a professional engineer (eyebolts and rings, stub columns)
- parapet clamps secured to sound parapet walls on the other side of the roof.

Items commonly found on roofs that should not be used to secure tie-backs include light sheet metal chimneys and roof vents, TV antennas, masonry chimneys and similar unsafe supports.

The tie-back securing point on the structure should be lower than or level with the securing point on the thrust-out. This ensures the thrust-out will not tilt if there is an overloading condition.

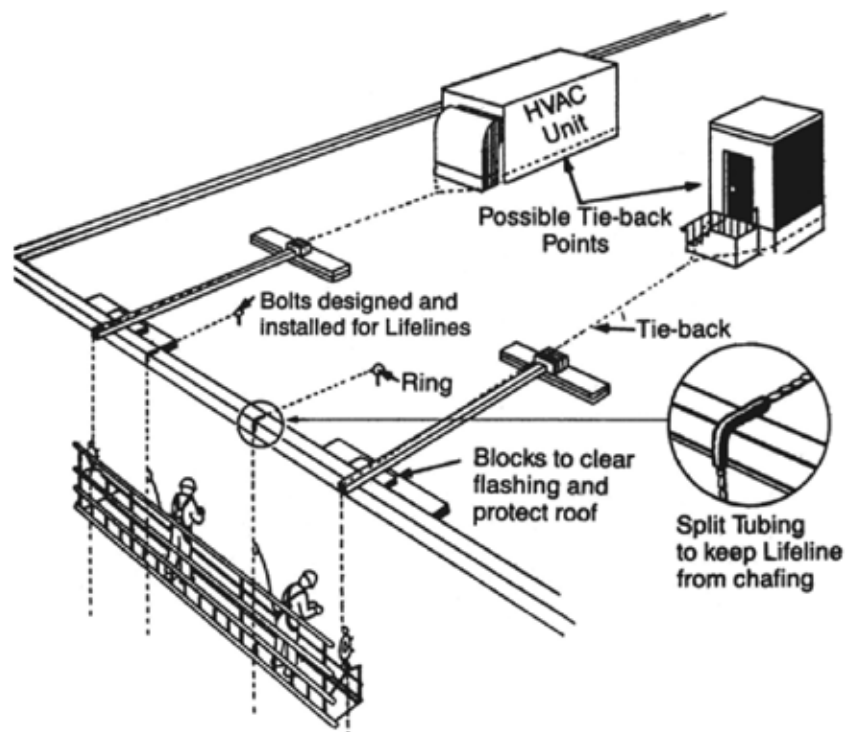

6. Parapets

If the parapet edge is the fulcrum point for the thrust-out, it is important that the parapet is stable and able to support the load of the swing stage. If in doubt, a professional engineer must be consulted.

If the building has an unusually high parapet wall or a parapet that cannot support the thrust-out, then scaffolding can be used. The thrust-out must be secured to the scaffold, and the scaffold secured to the building (tied back). The scaffold structure must be approved by a professional engineer or certified by the manufacturer to support the loading condition.

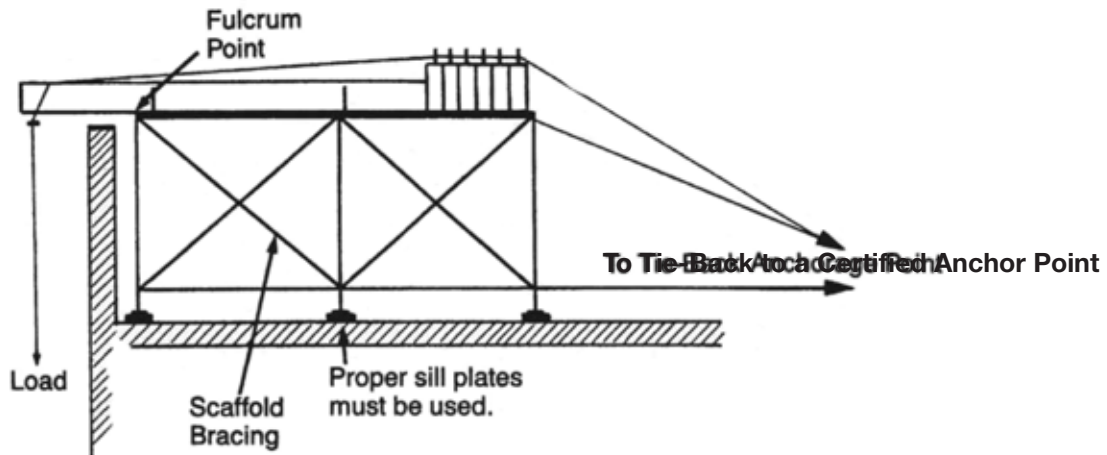

7. Suspension to Thrust-out

Thrust-outs must have a suitable method for attaching suspension cables. A common method is the use of a proper eyebolt assembly secured to the outboard end of the thrust-out.

A shackle or positive locking safety hook must be attached to the eyebolt. The shackle pin must be secured so it cannot loosen.

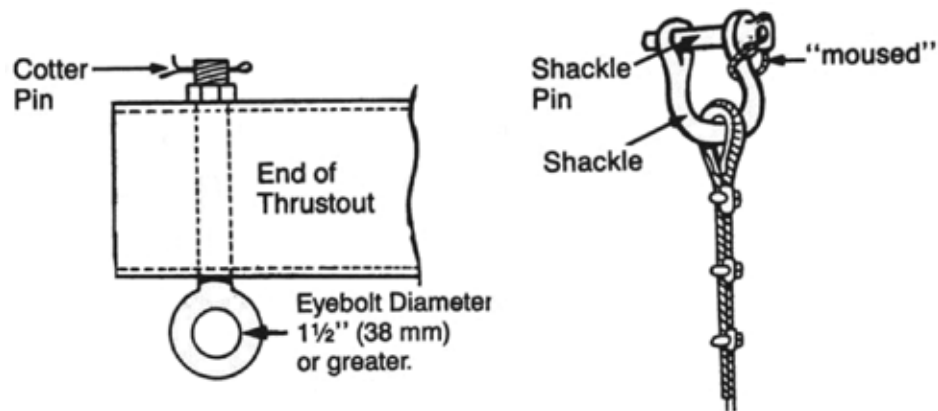

8. Wire Rope

Use only wire rope of the type, size, construction and grade recommended by the manufacturer. The minimum size of steel wire rope used with suspension hoisting devices is normally 8 mm (5/16 in.) diameter.

Wire ropes should be free of kinks, bird-caging, excessive wear, broken wires, flat spots or any other defects.

Wire ropes used as static lines or tie-backs for outrigger beams should be attached with cable slips of the appropriate size, torqued to specification and correctly installed.

All wire rope used with suspended access equipment should have a safety factor of 10 against failure (the manufacturer's catalogue breaking strength).

All wire rope must extend to the ground or be looped back and clipped. This prevents suspended devices, or devices that are raised or lowered, from coming off the end of the wire rope. These support wire ropes must undergo proper inspection, storage and lubrication, according to their manufacturer's specifications.

9. Rigging Hardware

Rigging hardware should be capable of supporting at least 10 times the maximum load to which it may be subjected. This applies to all hooks, shackles, rings, bolts, slings, chains, wire ropes and splices.

Shackles, wire rope clips and hooks shall be drop-forged alloy steel having a safety factor of 10 against failure. All rigging must comply with the American Society of Mechanical Engineers (ASME) standards.

10. Wire Rope Clips

The only correct method of attaching U-bolt wire rope clips to rope ends is shown in the following illustration. The base of the clip bears against the live end of the rope, while the U-shape of the bolt presses against the dead end. The clips are usually spaced about six rope diameters apart to give adequate holding power.

A wire rope thimble must be used in the loop eye to prevent kinking when wire rope clips are used. Before ropes are placed under tension, the nuts on the clips must be tightened. It is advisable to tighten them again after the load is on the rope to take care of any reduction in the rope's diameter caused by the weight or tension of the load.

Note: Malleable, non-rated, wire rope clips are not to be used for connecting wire ropes for swing stage operations.



Application of U-Bolt Type Wire Rope Clips:

Step 1

Always refer to the manufacturer's specifications for the clip size, correct number of clips, amount of rope turn-back and correct torque application. Turn specified amount of rope from thimble to loop.



Apply the first clip one base width from the dead end of the rope. Apply U-Bolt over dead end of wire rope. The live end rests in the saddle. Tighten nuts evenly; alternate from one nut to the other until reaching the recommended torque.

Step 2

When two clips are required, apply the second clip as near the loop or thimble as possible. Tighten nuts evenly, alternating until reaching the recommended torque. When more than two clips are required, apply the second clip as near the loop or thimble as possible, turn nuts on second clip firmly, but do not tighten. Proceed to step 3.



Step 3

When three or more clips are required, space additional clips equally between the first two – take up rope slack – tighten nuts on each unequally between first two – take up rope slack – tighten nuts on each U-bolt evenly, alternating from one nut to the other until reaching recommended torque.



IMPORTANT: Apply a load to test the assembly. This load should be of equal or greater weight than loads expected in use. Next, check and retighten nuts to recommended torque.

11. Wire Rope Inspection

Wire rope is made of steel wire strands with a fibre or wire core. Select wire rope according to manufacturer's recommendations.

Check wire rope every working day. Ensure wire rope is well lubricated. All wire rope must be inspected by trained personnel, with a written, dated and signed report of rope condition.

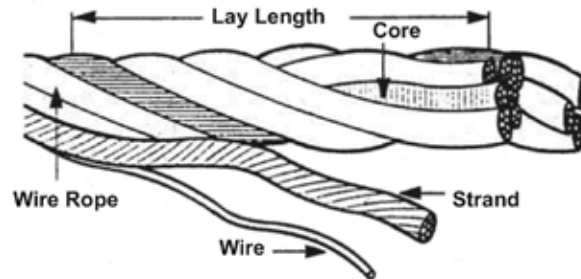

Estimate wire rope condition at section showing the most wear. Discard wire rope if any of the following conditions exist:

- in running rope (wind on drums or pass over sheaves), six or more broken wires in one lay length; three or more broken wires in one strand in one lay
- in pendant standing ropes, three or more broken wires in one lay length
- wear of one third of the original diameter of individual outside wires
- kinking, crushing, cutting or un-stranding
- heat damage
- excessive stretch or sharp reduction in diameter

12. Cornice Hooks

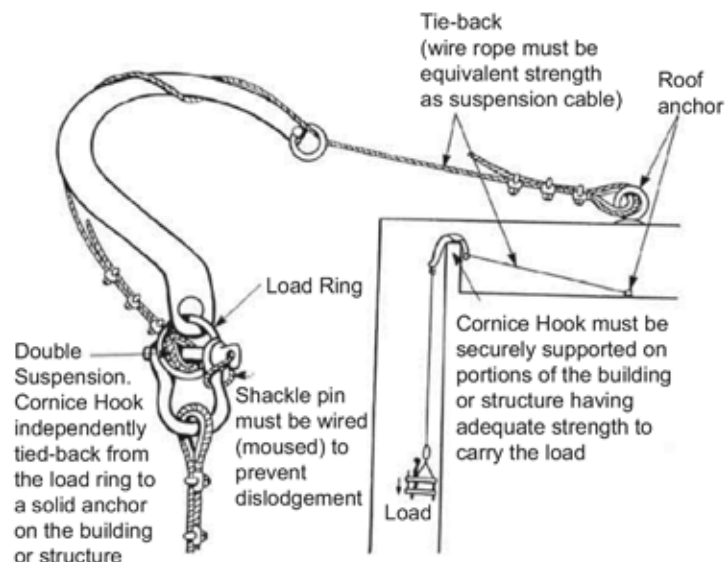

A steel cornice hook (sometimes called a parapet hook) is used to suspend a work platform when the roof configuration is such that outriggers cannot be used. They are usually placed over a parapet wall at the roof, although they could be placed over a beam or block wall, assuming the support is structurally sound.



Cornice hooks should be used only in locations where it is impossible to use thrust-out beams. The load ring must be securely tied back to the building structure, as shown in the diagram.

The cornice hook must be commercially manufactured or approved by a professional engineer and the rated hoisting capacity identified on the hook.

It is important that cornice hooks be securely supported on portions of the building or structure having adequate strength to carry the load. If there is doubt as to the strength of the support, a professional engineer should be consulted.

Serious incidents have occurred when cornice hooks were used on old buildings and the parapet wall collapsed from the loading conditions imposed on the wall.

3. Hoisting Apparatus

A number of different mechanisms are used in hoisting the swing stage, including manual winches and powered swing stage hoists.

i. Manual Winches (Climbers): Each set consists of a pair of smooth parallel jaws of suitable length that grip a wire rope firmly by closing top and bottom without causing damage to the rope. These jaws are self-clamping. They are locked by the pulling force of the wire rope itself. The greater the pulling force, the tighter they will grip. The jaw-blocks are enclosed in a casing and connected by rods to up-and-down mechanisms that are operated by a telescopic handle.

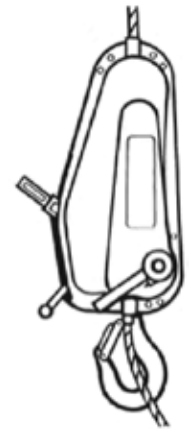

Be sure to check that the capacity of the winch, as rated by the manufacturer, is adequate for the load to be suspended.

The wire rope must be of a type, size and construction specified by the manufacturer of the winch. The principles of wire rope inspection discussed earlier also apply with the use of manual winches.

ii. Powered Hoists: Powered hoists usually attach directly to steel or aluminum stirrups located on each end of the stage platform, just outside the working deck. These units weigh 36 to 55 kg (80 to 120 lb.) and care must be taken when handling and rigging them.

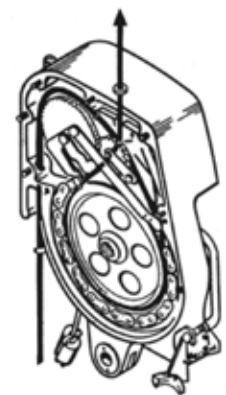

The electric units are designed to use either 110-volt or 220-volt power. Some are designed to use both voltages and may be switched by making internal wiring changes. Some actually feature an external voltage input selection switch.

Electric or air-powered hoists either climb the steel wire rope or spool it on a drum. On the machines that climb, the cable hangs from the suspension point into the traction mechanism of a hoisting device (see illustration) attached to the stage platform.

All power hoists must have built-in safety devices that need to be maintained to work correctly at all times.

It is extremely important for the user of each powered hoist to be completely familiar with all operating features of the unit. Detailed instruction and maintenance manuals should be obtained from the equipment supplier or directly from the manufacturer. Also, refer to CSA Standard CSA Z185-M *Safety Code for Personnel Hoist and* CSA Z256-M, *Safety Code for Material Hoists*.

4. Fixed Anchor Points

Where exterior windows are to be cleaned and maintained from the outside of the building, owners of buildings or structures more than 15 m (5 storeys) high constructed on or after July 2, 1985, are required to provide permanent window washing supports and facilities for suspending a work platform. Supports and facilities for these buildings and structures must meet the requirements of the *CSA Z271 Safety Code for Suspended Elevating Platforms*. These building and structures must also feature tie-back guides that provide positive engagement with the platform during its full vertical or inclined travel.

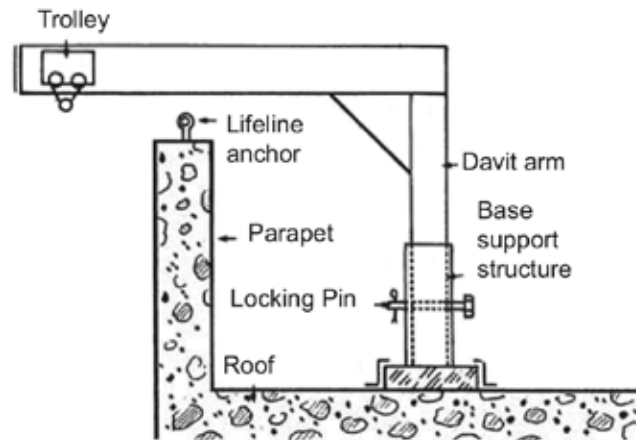

Permanent window washing structures are much more convenient and practicable means of ensuring the safety of workers using a suspended work platform. These structures eliminate the need to carry portable outrigger beams and counterweights onto the roof of a building. Some key elements to consider when designing and using such facilities include:

i. General

- a. The design and fabrication of all roof supports, outriggers, trolleys, hooks, securements, anchors and related equipment for the systems shall be specified by a professional engineer.
- b. The system shall be constructed of corrosion-resistant materials (e.g., aluminum, galvanized steel).
- c. Where an outrigger davit system is used, a guardrail or parapet 1 m (3.28 ft.) high must be provided at the edge of the roof.

ii. Outriggers (Davits)

- a. The outrigger (davit) shall fit securely into the base of the support structure and in a manner that ensures it cannot come free of the base during operating conditions (e.g., the use of a bolt or other means of securing the outrigger with a positive-type locking device).
- b. The outrigger shall be equipped with an end stop to ensure the trolley cannot leave the end of the beam.
- c. Each outrigger beam shall have the maximum load capacity of the beam (at full extension) legibly marked in large letters on the beam.



iii. Trolley

- a. The trolley shall move easily along the outrigger and may be designed to be fixed in position at certain locations along the beam.
- b. The trolley shall be equipped with a suitable anchoring system for securing the wire cable supporting the swing stage (e.g., a rated eyebolt, shackle or other acceptable means).
- c. If there is a wheeled trolley supported by an I-beam, then drop stops shall be built into the design to support the trolley if there is failure of a wheel or axle.

iv. Anchors

- a. Lifeline anchors shall be capable of supporting 2,268 kg (5,000 lb.) in all directions.
- b. Lifeline anchors shall be located, ideally, at one-third intervals between the outrigger support bases and at locations that limit lifeline wear on corners and edges of the building.
- c. Eyebolts used as anchors shall be made of material not less than 19mm (3/4 in.) in diameter with an eye opening of not less than 38 mm (1.5 in.).

Interior Hung

An interior hung scaffold is a suspension scaffold consisting of a platform suspended from the ceiling or roof structure by fixed length supports.

Such scaffolds are to be suspended only from the roof structure or other structural members (e.g., ceiling beams). Overhead supporting members require inspection for strength before scaffold erection. Suspension ropes and cable must be connected to the supporting members by shackles, clips, thimbles or equal means. All interior hung scaffolding must be designed and built by a professional engineer.

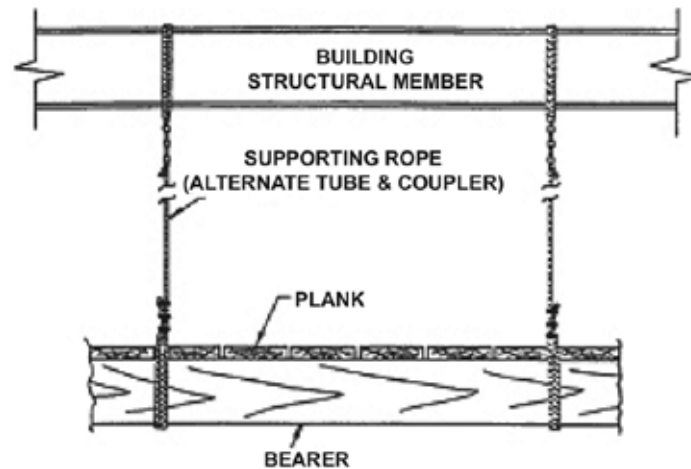

Suspended Man Baskets

Because its failure can have catastrophic consequences, a suspended man basket (also called a personnel basket) that has not been commercially manufactured must be designed and certified by a professional engineer as safe for use.

A commercially manufactured, suspended man basket may be manually operated or power driven, is generally suspended from a thrust-out, and is equipped with a separate vertical lifeline.



Suspended man basket

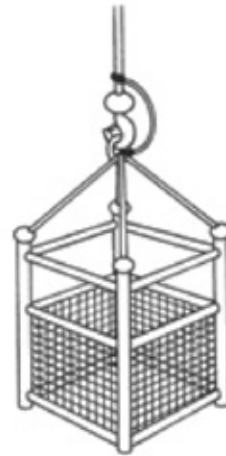

Commercially manufactured suspended man basket designed and certified by a professional engineer

A crane is the only method permitted to hoist a man basket or cage.

When a crane is used to hoist a man basket, **prior notification must be given to the Workplace Safety and Health Branch** regardless of the height of the hoisting operation.

When a man basket or cage is designed by a professional engineer, the engineer must inspect the basket or cage before its first use and certify that it has been manufactured according to the design specifications.

Under normal circumstances, a person working from a man basket is protected from falling by using a personal fall arrest system, such as a vertical lifeline/rope grab combination or a self-retracting lifeline. The lifeline is secured to anchor points above the load hook on the boom of the crane from which the man basket is suspended.

In situations where connecting a load hook might risk injury to the worker from the basket roof or connection points, both of the following may apply:

- A separate man basket support must be attached between the suspended man basket and the hoisting line above the hook assembly.
- Each worker within the man basket must wear a full body harness with lanyard securely attached to the man basket.



The separate or secondary man basket support, in combination with the worker being attached to the man basket, will function as a fall arrest system. The picture of the commercially manufactured basket on the previous page shows the secondary basket support, the wire loop around the hook attached to the main line above the headache ball. To limit fall distance and the arresting force experienced by workers inside the basket, the secondary support must be kept as short as possible to prevent the basket from falling more than 15 cm (6 in.) should it become dislodged from the primary support hook.

All man baskets must be equipped with a guardrail system, consisting of a top and mid rail and a skid resistant deck. The man basket must also have the following legibly and permanently marked in a conspicuous place on it:

- the maximum number of workers who may occupy the basket
- its weight
- the crane type for which it has been designed
- any other information necessary for safe operation of the basket.

When a crane is used to hoist a man basket, emergency rescue procedures must be developed and the workers involved in the hoisting operation must be trained in how to apply them. There must also be adequate means of communication between the worker or workers in the personnel basket or cage and the crane operator.

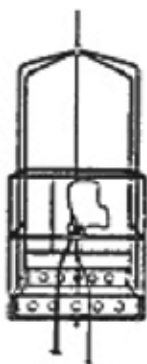

POWER TRACTION HOIST
WORK CAGE

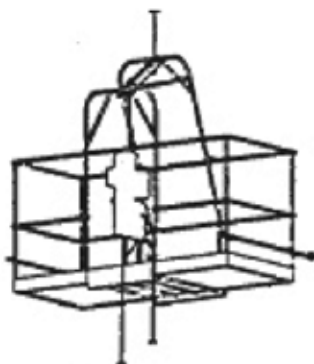

POWER TRACTION HOIST
WITH CAGE WITH EXTENSIONS



SINGLE POINT SUSPENSION
SCAFFOLD WINDING DRUM HOIST

AERIAL DEVICES AND SELF-ELEVATING WORK PLATFORMS

1. Self-Elevating Work Platforms

Only qualified people, who have been trained and familiarized in the inspection, application and operation of an aerial platform, including recognizing and avoiding hazards associated with their operation, can operate an aerial platform. All operators must be able to demonstrate competence in the operation of the aerial platform.

The work platform must be equipped with a guardrail or other equivalent structure. Chain, or its equivalent, may be substituted as the top rail or mid rail across an access opening. All fall protection systems must be used in accordance with manufacturer's specifications, and conform to *WSH Regulation, Part 14*.

Outriggers, stabilizers, extendable axles, oscillating axles or other stability enhancing means must be deployed and locked into place as required by the manufacturer. Where outriggers are used to level the chassis, they must be deployed according to the manufacturer's instructions and limitations.

Elevating work platforms must not be loaded in excess of rated loads. They must also not be loaded or used in a manner that affects stability or endangers workers.

A complete and concise record of any information concerning regular inspections (daily inspection exempted), tests, maintenance and structural inspections, electronic and machine repair that has a direct bearing on the safety of the aerial platform shall be kept permanently by the owner. Where the owner of the platform is also the supplier (the rental company), this record should be made available to the employer (the renter).

- a. **Daily** – All components having a direct bearing on the safe operation of the aerial platform, and subject to change with daily use, shall be visually inspected daily by the operator.
- b. **Periodic** – This inspection shall be performed after each 200 hours of use or after a period recommended by the manufacturer, whichever comes first. The interval between inspections may vary depending on the aerial platforms' activity, severity of use and the working environment. Periodic inspections shall be performed by a qualified person.
- c. **Annual** – This inspection shall be performed annually, or after every 700 hours of use, whichever comes first. A complete inspection of the aerial platform shall be performed by a qualified person. The inspection shall comply with the requirements of periodic and daily inspections and shall include, but not be limited to, all critical and suspect areas and all accessible structural elements and welds.



d. Structural – A structural inspection shall be required to verify the structural integrity of critical components of the aerial platform and its stability in accordance with the standards in effect at the time of manufacture. The structural inspection shall be carried out under the direction of a professional engineer. The aerial platform shall be certified to meet the requirements of the CSA standard. Structural inspection shall be performed:

- 10 years after the date of manufacture and every five years thereafter
- after any incident that either damaged the aerial platform or may have affected its structural integrity or stability (e.g., electrical contact, shock loads, fall arrest, collision, unstable operation or cases involving overstressing)
- after a change of ownership, unless a complete service history is provided, including maintenance and inspection records.

A permanent plate must be located on the platform that lists:

- the make, model, serial number and manufacturer's name and address
- the rated working load
- the maximum platform height and horizontal reach; any warnings specified by the manufacturer
- special warnings, cautions or restrictions necessary for safe operation, including the use of outriggers or stabilizers and extendable axles
- the specific firm level surface conditions required for use of the platform or aerial device in the elevated position
- the operating instructions and a notice indicating the need to read the operating manual before use
- the name and number of the standard to which the platform was designed

The manufacturer must provide each aerial platform with an appropriate manual; the manual must be kept with the equipment at all times.

a. Self-Propelled Boom-Supported Elevating Work Platforms

CSA Standard B354.4 *Self-Propelled Boom-Supported Elevating Work Platforms* applies to all integral frame, boom-supported, elevating work platforms used to position personnel, along with their tools and necessary materials, at overhead work locations.

The boom may telescope, articulate or rotate and extend the platform beyond the base dimensions. The platform is power-operated with primary functions controlled from the platform. The equipment may be manually propelled or self-propelled. The following figure shows examples of typical boom-type elevating work platforms.



An articulated boom is a boom made of two or more hinged sections that support the work platform. A telescoping boom is one in which motion created between two or more boom sections is in a longitudinal direction that lengthens or shortens the boom.



Telescoping Boom

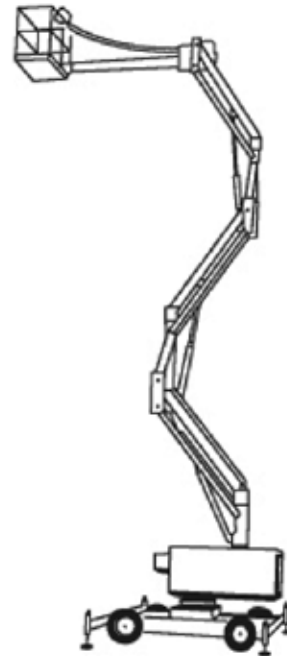

Articulating Boom with Outriggers

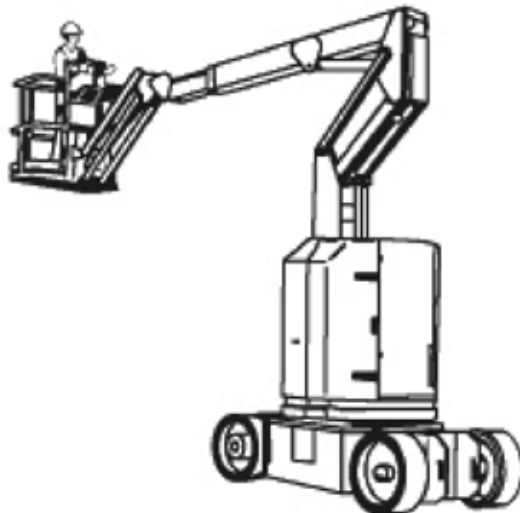

Articulating/Telescoping Boom (Rotational Swing)

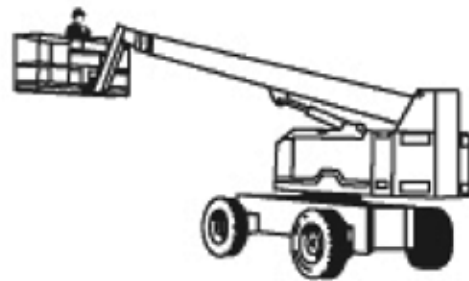

Telescoping Boom with Articulating Platform



b. Self-Propelled Elevating Work Platforms

CSA standard *CAN/CSA-B354.2 Self-Propelled Elevating Work Platforms* applies to self-propelled integral chassis elevated work platforms that have a platform that cannot be positioned completely beyond the base and that are used to position personnel, along with their necessary tools and materials, at work locations.

Self-propelled elevating work platforms (aerial platforms) are power-operated with primary functions, including drive, controlled from the platform. The standard applies to aerial platforms designed for use in both on-slab and off-slab applications. An on-slab surface means any asphalt, concrete or equivalent surface. An off-slab surface is an uneven surface made of materials other than asphalt, concrete or their equivalent. Compacted soil is an example of an off-slab surface. Work platforms intended for off-slab work are more stable than those intended for use on paved/slab surfaces.

The standard specifies the minimum requirements for the design, manufacture, remanufacture, rebuild/recondition, testing, performance, inspection, training, maintenance and safe operation of self-propelled elevating work platforms.

Self-propelled elevating work platforms are generally intended for use over level surfaces. Normally, they are not insulated for use near electrically energized circuits, nor are they intended for use in hazardous locations. The term self-propelled means the machine can be power-driven using a primary set of operator controls located on the elevated work platform.

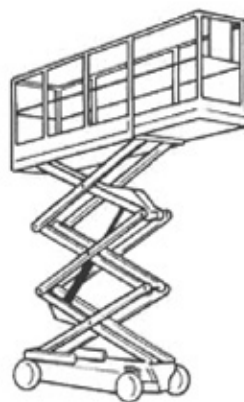

On-Slab Unit

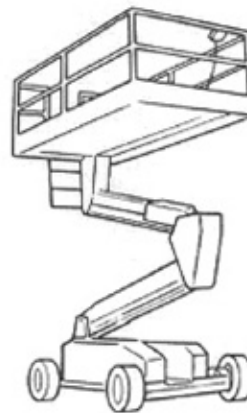

Off-Slab with Boom Elevating Mechanism

c. Portable Elevating Work Platforms

CSA standard *CAN/CSA B354.1 Portable Elevating Work Platforms* applies to portable, integral chassis, elevating work platforms with bases that cannot be driven or moved horizontally while the platform is elevated. Various designs can be moved, articulated or adjusted by manual or powered means to position workers, along with their tools and materials, at overhead work locations.



The standard describes requirements and recommended practices for product design and manufacture, lists performance criteria and sets standards for testing and inspection.

There are two types of portable elevating work platforms:

- **A type 1 aerial platform** is an elevating platform that cannot be positioned completely beyond its base.

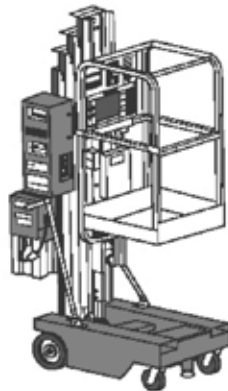

Type 1 manually propelled aerial platform

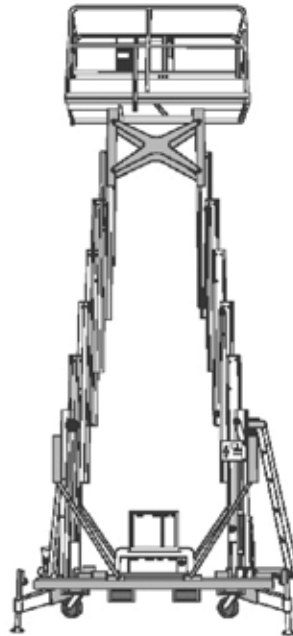

Type 1 manually propelled multi-mast or two-mast aerial platform

- **A type 2 aerial platform** is an elevating platform that can be positioned completely beyond its base.

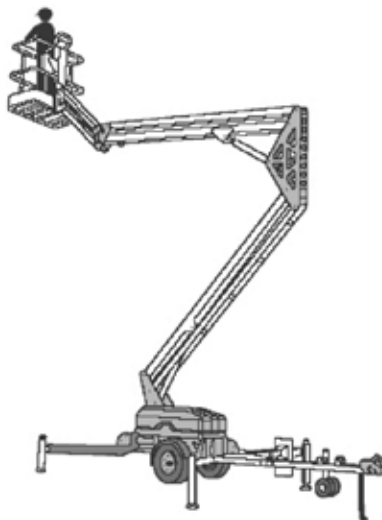

Type 2 towable aerial platform

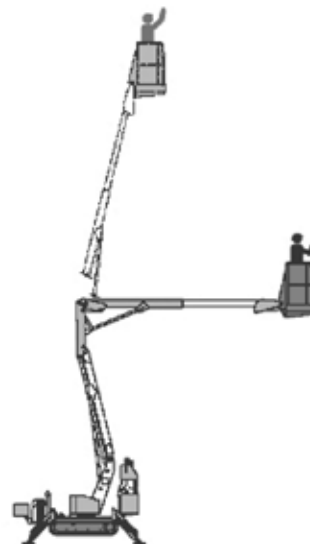

Type 2 track mounted aerial platform operating envelope shown



The images that follow show the types of equipment to which this standard applies.

Type 1 aerial platforms designed to allow use with the guardrail system or sections of the guardrail system removed shall have anchorages for personal fall protection. Type 2 aerial platforms are required to have anchorages for personal fall protection.

2. Vehicle-Mounted Aerial Devices:

CSA standard *C225 Vehicle Mounted Aerial Devices* applies to the following types of vehicle-mounted aerial devices: extensible boom platforms, aerial ladders, articulating boom platforms, vertical towers and a combination of any of this equipment.

These devices are installed on a chassis, are primarily used to position workers for work purposes. The vehicle may be a truck, trailer or all-terrain vehicle. Aerial equipment may be made of metal, wood, fiberglass, reinforced plastic or other materials. It may be powered or manually operated. Such equipment is considered an aerial lift, whether or not it is capable of rotating around a vertical axis. The figure to the right shows a typical aerial device.

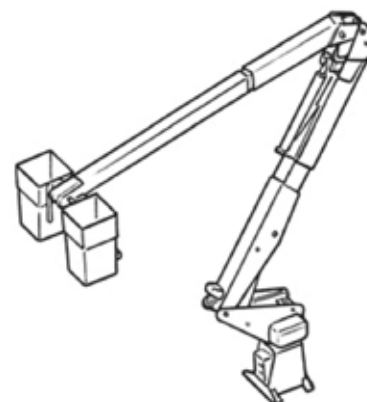

The standard requires the work platform to be equipped with a fall arrest anchor capable of withstanding a load of 22.2 kN (5,000 lbs of force).

Only workers who have received training in the inspection, application and operation of aerial devices, including recognition and avoidance of hazards associated with their operation, can operate an aerial device.

Platforms other than buckets or baskets must include a guardrail system. The guardrail system shall include a top rail and a mid rail around the platform. The platform must include toe boards or kick-plates on all sides. Although a guardrail system is present, fall arrest fall protection equipment is still required and must meet the requirements of *WSH Regulation, Part 14*.

A-frame, H-frame or swing-down outriggers must be deployed and locked into place as required by the manufacturer. Where outriggers are used to level the chassis, they must be deployed according to the manufacturer's instructions and limitations.

The inspection procedures for mobile units are divided into two classifications based on inspection and test intervals. Safe intervals must be set by the owner as recommended by the manufacturer. Intervals depend on component function, wear, deterioration and other agents that adversely affect component life. Two classifications are designated:

- Frequent inspection and test (daily to monthly intervals) – Items determined by the owner, based on recommendations by the manufacturer for each specific aerial device, shall be inspected for defects. Inspection and tests referred to as critical in the manufacturer's manual shall be strictly adhered to. Frequent inspections and tests include those conducted by the operator once daily and prior to first use. (For specific inspection criteria, see the CSA standard C225.) All unsafe items noted during the inspection must be replaced or repaired before use.
- Periodic inspection and test (one to 12-month intervals) – An inspection of the mobile unit shall be performed at the intervals of one to 12 months, as determined by its activity, severity of service and environment, or as specifically indicated in CSA standard C225.

A complete and concise record of any information concerning frequent and periodic inspections (daily inspection exempted), tests, maintenance and structural inspections, and electronic and machine repairs that has a direct bearing on the safety of the aerial platform, shall be kept permanently by the owner.

The manufacturer must provide an operating manual and a separate parts and maintenance manual for each aerial device. The owner of the aerial device must ensure that the operating manual is stored on the mobile unit. The aerial device manufacturer must clearly state the following information in the manual and on the aerial device:

- make and model
- rated load capacity
- rated platform height
- maximum pressure of the hydraulic system and voltage of the electrical control system
- cautions and restrictions of operation, including the applicable ambient temperature range in which the aerial device may be used
- insulating aerial device category, if applicable
- multiple configurations.



Specific requirements

a. Ladder trucks and tower trucks

Aerial ladders must be secured in the lower travelling position by the locking device on top of the truck cab and the manually operated device at the base of the ladder, or by other equally effective means, before the truck is used for roadway travel.

b. Extensible and articulating boom platforms

An articulating boom platform device is an aerial device with two or more hinged boom sections. An extensible boom platform is an aerial device (except ladders) with a telescopic or extensible boom. Telescopic derricks with personnel platform attachments shall be considered extensible boom platforms when used with a personnel platform. Lift controls must be tested each day before use to determine that controls are in safe working condition. Only authorized individuals can operate an aerial lift. Connecting to an adjacent pole, structure or equipment while working from an aerial lift is not permitted. Employees are required to always stand firmly on the floor of the basket or use planks, ladders or other devices for a work position. A worker in an aerial lift must wear a full body harness and a lanyard that must be attached to the boom or basket.

Boom and basket load limits specified by the manufacturer must not be exceeded. The brakes must be set and, when outriggers are used, they must be positioned on pads or a solid surface. Wheel chocks must be installed before using an aerial lift on an incline. An aerial lift truck must not be moved when the boom is elevated in a working position with workers in the basket except for equipment that is specifically designed for this type of operation.

Articulating boom and extensible boom platforms, primarily designed as personnel carriers, must have both platform (upper) and lower controls. Upper controls must be in or beside the platform within easy reach of the operator. Lower controls must provide for overriding the upper controls. Controls must be plainly marked as to their function. Lower level controls must not be operated unless permission has been obtained from the employee in the lift, except in case of emergency.

The insulated portion of an aerial lift must not be altered in any manner that might reduce its insulating value. Before moving aerial lifts for travel, the booms must be inspected to make sure they are properly cradled and outriggers are in stowed position.

MAST-CLIMBING WORK PLATFORMS

Mast-climbing work platforms (MCWP) are primarily used to position workers, including their tools and materials, so that work can be performed along highrise buildings. Platforms can be adjusted by manual or powered means. The CSA standard *CAN/CSA B354.5 Mast-Climbing Work Platforms* applies to these types of aerial lifts and typically includes the following features:

- one or more work platforms
- one or more masts that are
 - free-standing or laterally supported above their bases
 - of fixed or variable height
 - vertical or inclined between zero and 30° to the vertical
 - vertically supported only at their bottom or top
- a chassis that is static or capable of transfer to a work site by self-propulsion or towing
- an elevating mechanism that is manually or power operated; raising and lowering speeds are limited to a maximum of 0.20 metres / second (0.66 feet / second).

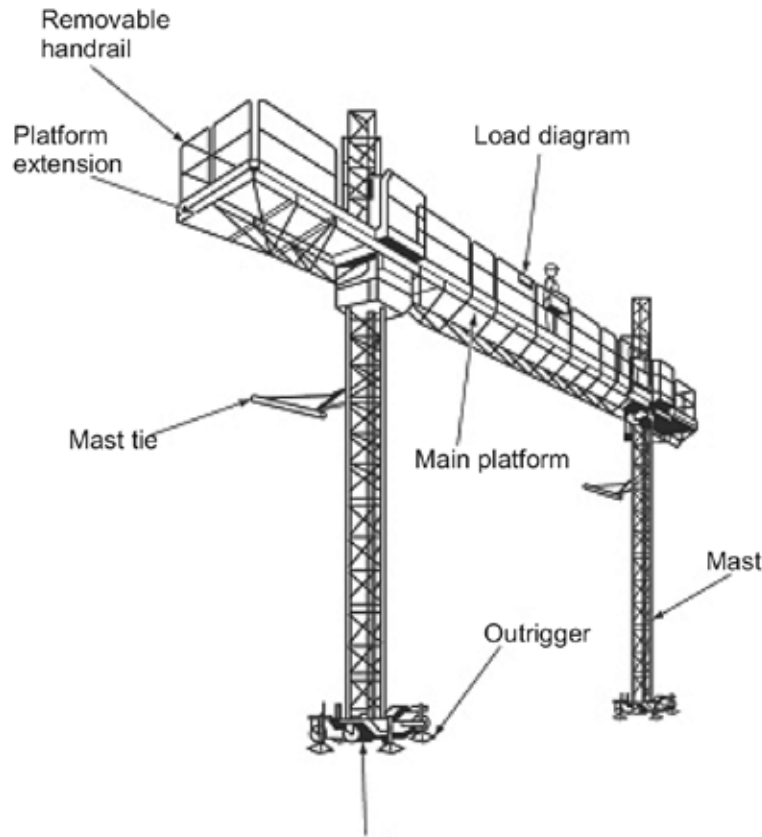

Typical Double-Mast MCWP



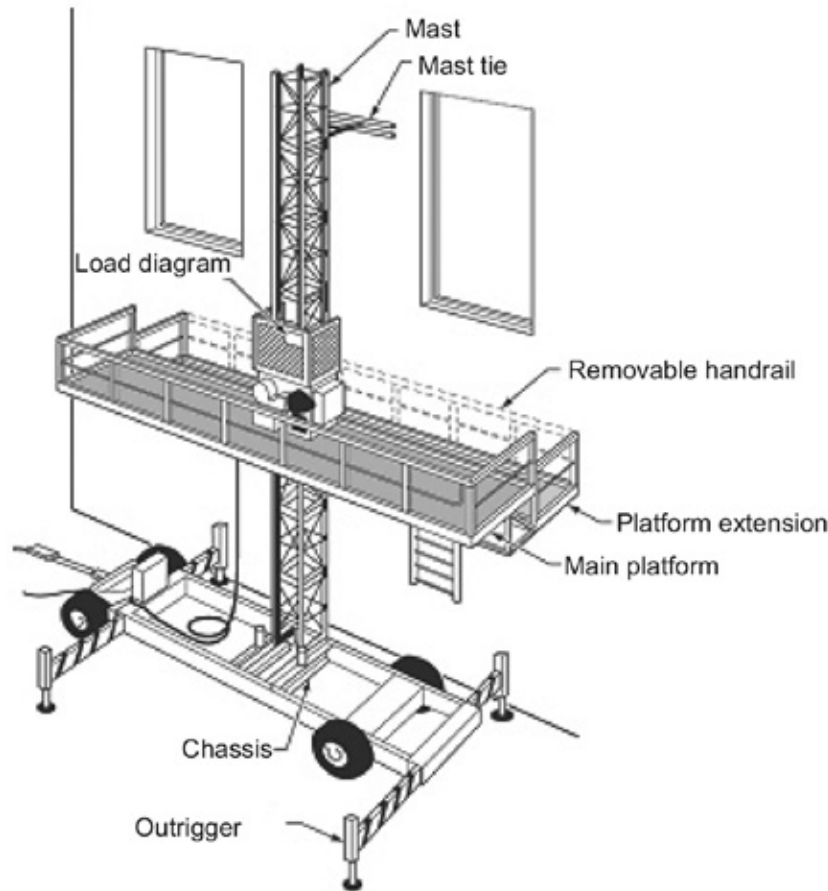

Typical Single-Mast MCWP

The main platform of an MCWP and any extensions must include a guardrail system around the periphery. The guardrail system includes a top rail, mid rail and toe board along all edges. Toe boards must not be omitted at access openings. A toe board 0.15 m (6 in.) in height must also be provided at the edge of the platform at the mast. Guarding to prevent access must be installed to a height of at least 2 m (6.6 ft.) at the mast whenever the:

- travel speed of the main platform and any extensions exceeds 0.06m/s (0.2 ft./s); or
- clearance between the platform and the mast is less than 150 mm (6 in.).

The work platform must be equipped with at least one fall protection anchorage for each occupant it accommodates. The location of the anchorages must be clearly identified. Each anchorage must be capable of withstanding a static force of 22.2 kN (5,000 lb. of force). Travel restraint fall protection systems used on an MCWP must meet the requirements of *WSH Regulation Part 14*.

At least one access gate must be provided, and it must not open outward.

All access gates must be constructed in such a manner that they close automatically or will prevent operation of the work platform unless they are closed. Inadvertent opening of the access gate must not be possible. Chains or ropes must not be used as access gates. Trap doors in the work platform are to be securely fastened and must not open downward.

The MCWP must be fitted with means to permit the manually controlled emergency lowering of the work platform.

Manufacturers and suppliers of MCWPs must provide technical and operating manuals with each piece of equipment. The manual provides information on safe operation of the MCWP according to the CSA and manufacturer's requirements. The manual also specifies instructions for maintenance, inspection, erection and dismantling, and the manufacturer's minimum training standards for operators of the equipment.

A complete and concise record of any information concerning regular inspections (other than pre-start inspections), tests, maintenance, structural, electronic and machine repair that has a direct bearing on the safety of the MCWP must be recorded and the record maintained by the owner.

All MCWPs must be inspected, tested and maintained according to requirements of the CSA and the manufacturer's recommendations. The MCWP must be inspected and tested after it has been erected and before initial use. It must also be inspected at the following intervals:

- a. Daily or pre-start inspection – All components having a direct bearing on the safe operation of the MCWP, and subject to change with daily use, shall be visually inspected daily by the operator. In addition, these components, where applicable and practicable, shall be observed during operation for defects that can affect the safe operation of the MCWP.
- b. Annual inspection – The elevating unit, mast and chassis shall be inspected annually by a person qualified to inspect the specific make and model of the MCWP.
- c. Modifications or major repairs – Examinations and tests after modifications or major repairs to an MCWP already in use shall consist of design checks and practical tests appropriate to the type of modification or repair.

Only personnel who have received training in the inspection, application and operation of MCWPs, including the recognition and avoidance of hazards associated with their operation, may operate an MCWP.

The only people who may erect an MCWP are those who have received training in the inspection, application, operation and erection of an MCWP, including training in the recognition and avoidance of hazards associated their erection and operation.



VEHICLE-MOUNTED BRIDGE INSPECTION AND MAINTENANCE DEVICES

The ANSI/SIA standard A92.8, *Vehicle-Mounted Bridge Inspection and Maintenance Devices* describes the requirements for the design, manufacture, testing, inspection, installation, maintenance, use, training and operation of such devices. The figure below shows typical examples of vehicle-mounted bridge inspection and maintenance devices.

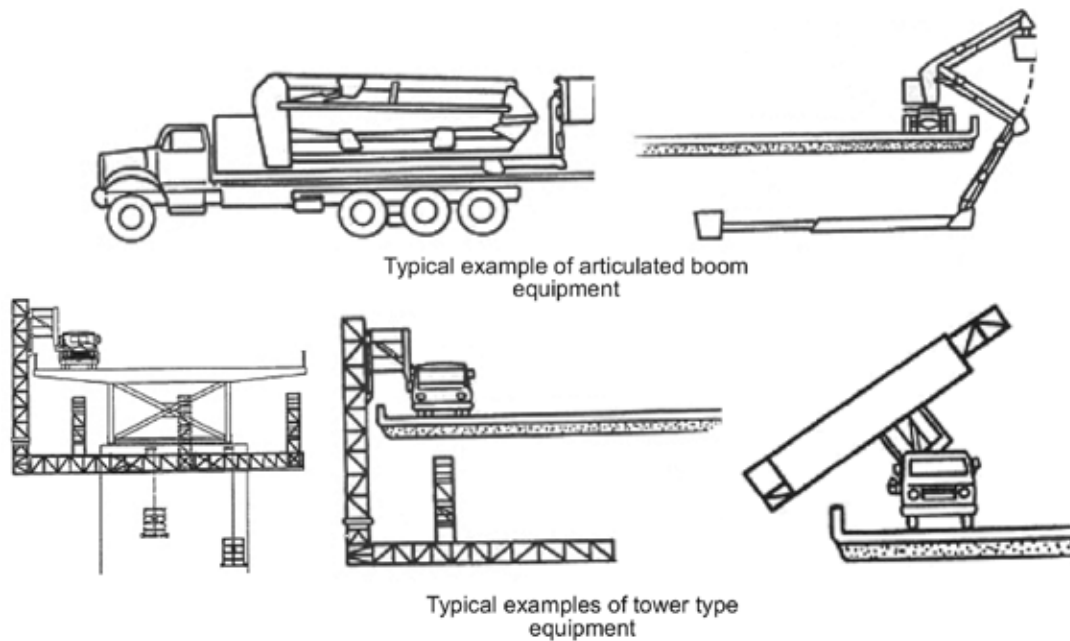

The mobile unit shall have both chassis and platform controls. All controls shall be:

- readily accessible to the operator
- marked clearly with durable materials that clearly identify control functions
- oriented in the approximate direction of the function they control, with the control box in its normal position for operation; control boxes not permanently attached shall have their normal location and orientation clearly marked
- designed to return to their neutral position when released by the operator
- powered for normal activation
- designed to prevent inadvertent operation
- protected from damage.

A control device that can stop platform and chassis movement in an emergency shall be provided at the platform and at the chassis control station. The control shall not require continuous actuation for a stop condition. This control shall always be operational so the unit can be stopped at any time from any station.

When workers on scaffolds cannot be seen from the operator station, the scaffold must have an emergency stop control. A voice-actuated, two-way communication system shall be worn by each worker on scaffolding to enable communication with operators at all times.

All platform floors must have a slip-resistant surface. Platforms must include a guardrail system consisting of a top rail, mid-rail and toe boards around outside edges. Travel restraint anchors must be provided to allow workers to attach a lanyard to the platform or boom. All travel restraint fall protection systems must meet the requirements of Part 14 of the *WSH Regulation*.

The manufacturer shall provide an operator's manual and a parts and maintenance manual for each mobile unit.

A dedicated, two-way intercommunication system between ground personnel and personnel on the platform shall be provided. Such communication devices on the platform shall be voice-actuated or in the normal transmit mode. In addition to the voice-actuated devices, communication devices may also include camera monitors, in the event that verbal communication cannot be provided.

The owner of each *Vehicle-Mounted Bridge Inspection Device* is responsible for the following tests and inspections:

- a. **Initial inspections and tests** – Prior to initial use, new, modified or remounted units shall be inspected and tested to ensure compliance with the provisions of this standard. Initial inspections and tests shall be certified by the manufacturer, installer or equivalent entity.
- b. **Regular inspections and tests** – Regular inspection procedures are divided into three classifications:
 - i. **Daily inspection** – Each day before use, or at the beginning of each shift, the mobile unit shall be given a visual inspection and functional testing. See the ANSI standard for detailed inspection requirements.
 - ii. **Frequent inspection** – Frequent inspections and tests shall be conducted on the mobile unit:
 - when it has been in service for three months or 200 hours, whichever comes first before operating it, after the unit has been out of service for longer than three months.
 - This inspection shall be made by a person qualified as a technician for the specific make and inspection and applicable ANSI standards (see the ANSI standard for detailed inspection requirements).
 - iii. **Annual inspection** – After 1,000 hours of operation or 12 months after the previous annual inspection, whichever comes first, an annual inspection must be performed. Inspections shall be performed by a person qualified as a technician for the specific make and model of the mobile unit. The inspection shall include all items specified by the manufacturer for the annual inspection and applicable ANSI standards (see the ANSI standard for detailed inspection requirements).

Before operating the equipment, all malfunctions and problems identified must be corrected and a further inspection, if necessary, must be completed. A record must be kept showing:

- the name and signature of every person involved in carrying out the inspection
- a description of any deficiencies found
- a listing of all corrective actions and repairs done
- the name and signature of each person performing the repairs.

Whenever the installer delivers the mobile unit to a dealer or owner, he or she must provide training in operation, inspection and maintenance of the unit.

Individuals who are not continuously employed as operators on the model, or a unit having identical controls, and who have not operated such a unit for 90 days, must undergo a review of their operating knowledge and a proficiency review by a qualified person who can determine their competency.



LIFT TRUCK MOUNTED WORK PLATFORMS

This section applies to a cage or work platform mounted on the forks of powered mobile equipment. The cage or work platform must be securely attached to the lifting carriage and forks of the powered mobile equipment. Doing so prevents the cage or platform from accidentally moving laterally or vertically and prevents the powered mobile equipment from tipping.

Since the work platform is intended to support a worker, it must meet a higher standard of design and construction than is required for a platform intended to support only material. This means that the work platform must be commercially manufactured or designed and certified by a professional engineer.

The work platform must be equipped with guardrails and toe boards. Guardrails act as a type of fall protection and the toe boards prevent small objects from falling off the platform. The platform must be equipped with a skid-resistant deck and a screen or similar barrier that guards any drive mechanism accessible to a worker while on the work platform.

When a worker is on a work platform mounted on a lift truck, the worker must wear fall protection. The fall protection system can be either a travel restraint (the worker is connected to a manufactured or professionally engineered anchor point on the work platform) or where the worker is outside the basket, fall arrest (the worker is connected to an anchor point directly above or near the work area).

A worker on an elevated fork-mounted work platform relies on the equipment operator to position the platform. The operator must not leave the controls while a worker is on the elevated work platform.

Personnel must not be transported in the work platform, including between task locations. The platform is not designed to protect a worker from injury if the powered mobile equipment stops or starts suddenly, or in the event of a collision or upset. The work platform must be lowered to floor or grade level before a person gets on or leaves the platform.

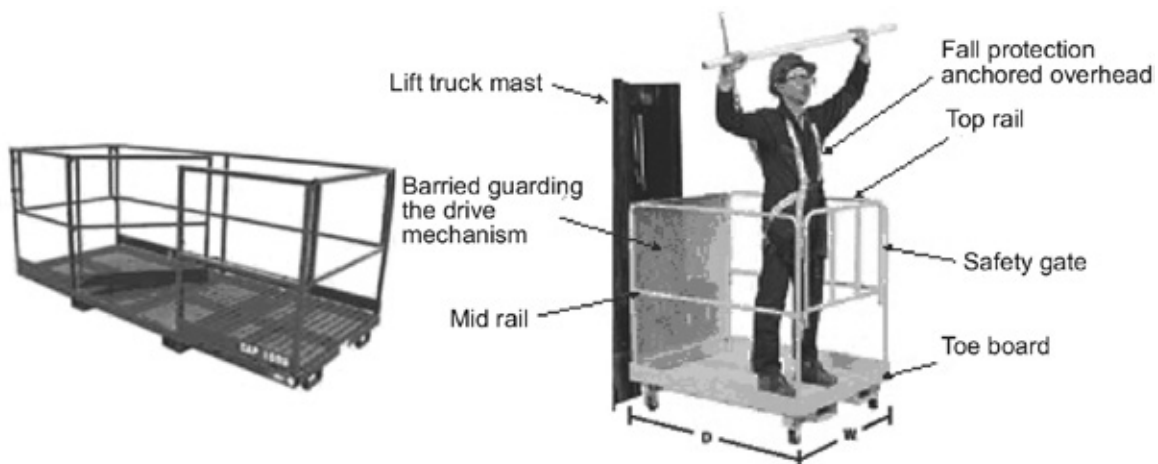

The work platform must be legibly marked to show:

- if a commercially manufactured work platform, the part number or serial number to allow the design of the work platform to be linked to the manufacturer's documentation
- if a custom-built work platform, a unique identification number or code that links to the design and certification documentation from the engineer
- the weight of the work platform when empty
- the maximum number of workers who may occupy the platform
- the rated load that may be placed on the work platform (the maximum combined weight of the people, tools and materials permitted on the work platform)
- the minimum rated capacity of the lift truck needed to safely handle the work platform, either by specifying the make and model of the lift trucks that may be used with the platform, or by specifying the minimum wheel track and lift truck capacity

A system for communication between the work platform occupants and the lift truck operator must be in place to allow control of work platform movement. If there is more than one occupant on the work platform, one person on the work platform must be designated to be the primary person to signal the lift truck operator regarding work platform movement requests. If hand and arm signals are not the main communication method, a system of hand and arm signals must be developed as an alternative, in the event that the primary voice or other electronic communication means becomes ineffective during work platform use.

Operators of a lift truck equipped with a work platform should:

- a. Ensure that the mast or boom travels only vertically and does not operate if the vehicle equipped with the platform is not on level ground or, in the case of a rough terrain lift truck, properly leveled to compensate for a sloped surface.
- b. Make sure the platform is kept horizontal, centred and not tilted forward or rearward when mounted on the lift truck at any elevation.
- c. Make sure the lift truck is on firm and level footing.
- d. Place all travel controls in neutral and set the parking brake.
- e. Before elevating workers, cordon off the area with cones or other devices to keep pedestrians and vehicles away from the work area.
- f. Make sure to lift and lower workers smoothly and cautiously.
- g. Maintain adequate clearance between the work platform and surrounding hazards, such as storage racks, scaffolds, overhead obstructions and electric wires.
- h. Keep hands and feet clear of controls other than those in use.
- i. Always lower the platform to the ground before moving the lift truck to adjust the platform position.
- j. Remain in a position to control the truck. The operator must not leave the controls of powered mobile equipment unattended.



APPENDIX A – SAFE WORK PROCEDURE SAMPLE

ABC Building Maintenance Ltd.
Exterior High-Rise Window Cleaning and Work Plan

(Job Title)

This task may only be performed by trained personnel

Location: 123 Easy Street	Job # 100567	Written By: A. Smith	Date Created: January 20, 2016	Date of Last Revision: March 10, 2016
-------------------------------------	------------------------	--------------------------------	--	---

Hazards Present:	Personal Protective Equipment (PPE) or Devices Required:	Additional Training Requirements:
<ul style="list-style-type: none"> • falls • heat exhaustion • sun exposure • struck by objects (materials falling onto workers) • overexertion • other trades in the area 	<ul style="list-style-type: none"> • protective headwear • protective eyewear • safety footwear • full body harness • lanyard with shock absorber • lifeline, carabiners • rope grab, anchor 	<ul style="list-style-type: none"> • fall protection training • rescue training

Safe Work Procedure:
<ol style="list-style-type: none"> 1. This job site requires the use of boatswain’s chairs suspended by two nylon primary suspension lines with a 13/16 (20 mm) diameter polypropylene lifeline. Note: <i>The height of the building must be determined in advance.</i> 2. Inspect all equipment before each working day and protect your equipment from exposure to roof tar and hazardous chemicals during the working day. Lock your equipment overnight (never leave it exposed on the roof) to prevent rain falling on it. 3. Inspect all roof anchor points (as indicated on the roof sketch) before use. If any roof anchors are found to be unsafe, contact your supervisor or building representative immediately. 4. Never use a horizontal static line around any obstacles on the roof unless the roof sketch shows a building engineer has approved the static suspension. 5. All workers exposed to the danger of falling must wear a fall-arrest system consisting of a full-body harness connected to a lanyard or a shock absorber connected to a lifeline with a rope grab. 6. Primary suspension and lifelines must be anchored independently to separate anchor points, not exceeding a 25-degree angle, with a thimble on lines attached to a “D” ring or shackle, then attached to the anchor point.



7. Outrigger beams and parapet wall hooks (if needed on this job site) must be properly tied back to an anchor point not exceeding a 25-degree angle, with an adequate number of counterweights attached to the outrigger beam's end (opposite the tipping point). The safety pin that holds the two-piece beam together must have a wire or small pin holding the safety pin stationary.
8. Both primary suspension lines and the lifeline must have an edge protection at the roof's edge (e.g., carpet, rubber hose) to prevent abrasion or chafing of the ropes.
9. Post "**Danger – Work Overhead**" signs under the working area on ground level to warn pedestrians that you are above them.
10. Primary suspension and lifelines must be adequate to reach the ground with at least three metres of extra slack.
11. Once in the boatswain's chair, only windows within arm's reach can be safely cleaned.
12. All workers shall comply with the *Manitoba Workplace Safety and Health Act and Regulation* with particular attention to Parts 14 and 28 of the *WSH Regulation*.
13. Always exercise extreme caution to create a safe working environment on this job site. Never attempt to work in strong winds or rainy conditions.
14. Contact your supervisor with any problems or questions that arise on this job site.

Guidance Documents/Standards/Applicable Legislation/Other:

- *Manitoba Workplace Safety and Health Act and Regulation*
- *Guide for Scaffolds and Other Elevated Work Platforms*
- CSA Standards
- ANSI Standards

This Safe Work Procedure will be reviewed any time the task, equipment or materials change and, at a minimum, every three years.

All procedures obtained from operator manuals or other samples must be thoroughly reviewed to ensure they are accurate for your workplace and your jobs.



APPENDIX B

Site Maps | Contact Us (1-866-MANITOBA)

Search



Government Business Residents Online Services Visitors

Labour Programs

> Growth, Enterprise & Trade > Labour Programs > Workplace Safety & Health > Permits > Suspended Work Platform Permit

Suspended Work Platform Permit

Any employer in Manitoba who proposes to use a suspended work platform at a height in excess of 3 metres above ground, or intends to use a crane to suspend a personnel basket or cage at any height must give notice to the WSH branch **at least 6 hours before** the platform, personnel basket or cage is suspended.

Employers must not start work with the use of a suspended work platform without a valid serial number assigned by the WSH branch for the project.

To receive a valid serial number for suspended work platform use, the employer must ensure:

- All information in the suspended work platform permit application is accurate and up-to-date.
- Certified roof plans are readily available

Roof Plans

Roof plans are drawings and layout diagrams showing positions of approved anchors, tie-back points, and outrigger or davit arm placements used for suspended work operations at each physical location. At minimum, the following information must be provided to the employer by the building owner, along with additional information as determined necessary to do so:

- Plan view showing essential structural members, including anchors
- Details of the equipment and its installation
- The safe working loads of the equipment and any use restrictions on the equipment
- All relevant obstructions, structures or other obstacles that impede the safe operation of the equipment

Reference:

M.R. 217/2006, Workplace Safety and Health Regulation, Part 14: Fall Protection
SAFE Work Manitoba's "Fall Protection Guide"

All fields are required to submit this form

Company Name

Company Address City Province Postal Code

Contact Name Contact Phone Number

Suspended Work Address (Rural Areas Provide Direction)

Address City Province Postal Code

Description of the type of suspended work

Platform Type

Suspension Type

Approved Professional Engineer Roof Plan Yes No

Lifeline / Lanyard Provided Yes No

Type of Tieback

Rope / Cable Diameter in inches

Workers Trained in the Safe Work Procedures Yes No

Start Date End Date

Supervisor's First Name Supervisor's Last Name

Before hitting submit, please print a copy of the completed form for your records.
The confirmation number that appears upon submission will serve as your serial number.

GLOSSARY OF TERMS

Definitions

Aerial lift – A vehicle-mounted aerial device used to elevate personnel to job sites above ground.

Base plates – Devices used to support and distribute the vertical leg load of a scaffold system over a large area of a sill, and sized according to the manufacturer's specification.

Bracing – A system of members connecting frames or sections of scaffolding to make the scaffold structure while adding strength and rigidity between members.

Bracket scaffold – A platform supported by two or more triangular brackets projecting out from a building or structure to which the brackets are securely fastened.

Checking for plumb – Ensuring the scaffold is balanced and erected at a 90-degree angle straight up from a level surface.

Competent – Possessing knowledge, experience and training to perform a specific duty.

Coupling devices – A connecting device used to secure scaffold frames together.

Engineering design – The design of a scaffold system by an engineer licensed to practise in Manitoba. The sealed drawings of a scaffolding system should include all appropriate information on loading capacities and detailing on tie-backs, foundations, etc. These drawings must be kept on site.

Fall arrest system – A protection system designed to stop a worker's fall before the worker hits the surface below, usually consisting of a full body harness secured to a lanyard and lifeline.

Foundation – The surface upon which a scaffold is erected.

Full body harness – A device consisting of connected straps designed to fit the torso and pelvic area of a worker, with provision for attaching a lanyard, lifeline or other component.

Guardrail – A rail secured to uprights and erected along the exposed sides and ends of platforms. Part 14 of the *WSH Regulation* stipulates that the minimum height of the guardrail shall be 900 mm (3 ft.) and the maximum 1060 mm (3.5 ft.). The guardrail should be wood or metal, but not a bracing component.

Ladder-jack scaffold – A platform supported by brackets attached to ladders.

Lanyard – A flexible line of webbing, synthetic fibre or wire rope used to secure a full body harness to a lifeline or anchor.

Lifeline – A flexible synthetic line or rope made of fibre, wire or webbing rigged from one or more anchors to which a worker's lanyard or other part of a fall protection system is attached.

Mobile scaffold – A free-standing scaffold equipped with casters or wheels at the base.



Outrigger scaffold – A platform that is supported by rigid members cantilevered out from the building or structure, or from vertical supports.

Outrigger stabilizers – A device used to extend the support length at the base of the scaffolding in order to provide stability against overturning.

Planks – Refers to sawn lumber, 50 mm x 250 mm (2 in. x 10 in.) or wider, used in creating scaffolding platforms. All lumber dimensions are nominal.

Platform – A working surface provided on a scaffold to support the weight of workers, tools and materials.

Pump jack scaffold – A scaffold consisting of vertical poles, platform planking and movable platform brackets that travel on the vertical poles.

Sills – A footing of minimum 50 mm x 250 mm (2 in. x 10 in.) wood plank or other device used to distribute the load from a vertical support or base of a scaffold to the ground.

Suspended scaffold – is one or more platforms suspended by ropes or other non-rigid means from an overhead structure.

Tie-in – A reinforcing connection device that secures a scaffold to a fixed structure.

Toe board – A barrier secured along the sides and ends of a platform to help stop materials or tools from falling.

Tubular frame scaffold – A work platform supported by welded tubular frames, cross-braces and accessories.





SAFE Work Manitoba
204-957-SAFE (7233)
1-855-957-SAFE (7233)
information@safeworkmanitoba.ca
safemanitoba.com

SW2129E-06/12/16