

GUIDE TO TRENCH EXCAVATIONS (SHORING SUPPORT AND DRAINAGE MEASURES)



Utilities Technical Liaison Committee
HIGHWAYS DEPARTMENT
and
Geotechnical Engineering Office
CIVIL ENGINEERING DEPARTMENT

THE GOVERNMENT OF THE HONG KONG
SPECIAL ADMINISTRATIVE REGION

February 2003

**GUIDE TO TRENCH EXCAVATIONS
(SHORING SUPPORT AND DRAINAGE MEASURES)**

Utilities Technical Liaison Committee
HIGHWAYS DEPARTMENT
and
Geotechnical Engineering Office
CIVIL ENGINEERING DEPARTMENT

THE GOVERNMENT OF THE HONG KONG
SPECIAL ADMINISTRATIVE REGION

February 2003

FOREWORD

Trench excavations are carried out principally to allow installation or repair of public utilities, drains and sewers to serve populated areas. The Geotechnical Engineering Office (GEO) of the Civil Engineering Department (CED) recently undertook a study on failures of trench excavations in Hong Kong. The study found that between 1986 and 2000, there were at least 10 deaths and 4 injuries caused by the failures of trench excavations. The study also found that a number of landslides resulting in significant social disruption in recent years were related to trench excavations adjacent to slopes. Therefore, the study concluded that the risk from trench excavations is not low and some improvement measures should be done to enhance the safety standards of trench excavations in Hong Kong.

The findings of the study with recommendations on enhancement of the safety of trench excavations were presented to the Standing Committee on Slope Safety (SCOSS) of Environment, Transport & Works Bureau (ETWB). It was decided by the SCOSS that a Working Group should be formed under the Utilities Technical Liaison Committee (UTLC) of Highways Department to take the recommendations forward, including the preparation of a technical guide to trench excavations, and GEO/CED should provide technical assistance to the UTLC to prepare the guide.

The Working Group, composed of the major utility undertakings, representatives from Hong Kong Construction Association, the Association of Consulting Engineers of Hong Kong, Highways Department, Water Supplies Department, Drainage Services Department and Labour Department, in conjunction with GEO/CED prepared this Guide on good practice of shoring support and drainage measures for trench excavations. As part of the Government's continuing effort to promote a safe and healthy working environment, it is the intention of this Guide that the safety of the personnel involved in the works and also the general public who may be affected by trench collapses or failures can be enhanced.



(C. K. WONG)
Chairman
Utilities Technical Liaison Committee
Highways Department
February 2003

CONTENTS

	Page No.
Title Page	1
FOREWORD	2
CONTENTS	3
1.0 INTRODUCTION	5
2.0 OBJECTIVE AND SCOPE	6
3.0 PLANNING STAGE	7
3.1 Desk Study	7
3.2 Timing and Location	7
3.3 Statutory Requirements	8
4.0 DESIGN STAGE	9
4.1 Temporary Support Design	9
4.2 Design Considerations	10
4.2.1 Loading	10
4.2.2 Drainage	10
4.2.3 Groundwater Control	11
4.2.4 Existing Man-Made Slope Features	11
5.0 CONSTRUCTION STAGE	12
5.1 Installation of Support	12
5.2 Special Drainage Provisions in the Wet Season	12
5.3 Backfilling of Trench and Reinstatement	13
5.4 Precaution in Use of Machinery	13
5.5 Other Considerations	14

6.0	SITE SUPERVISION AND SITE SAFETY INSPECTION	15
6.1	Site Supervision	15
6.2	Site Safety Inspection	16
6.3	Safety Checklist for Supervisors	16
6.3.1	Drainage Provisions	17
7.0	REFERENCES	19
	APPENDIX A : TYPICAL ARRANGEMENT OF SHORING DETAILS	21
	APPENDIX B: RECOMMENDED DRAINAGE MEASURES	34

1.0 INTRODUCTION

The Geotechnical Engineering Office (GEO) of the Civil Engineering Department (CED) recently carried out a study on failures of trench excavations in Hong Kong. The study included a review of known past failures of trench excavations, and also the current technical standards and statutory requirements for trench excavations. The study has revealed that, between 1986 and 2000, fifteen reported failures associated with trench excavations resulted in 10 deaths and 4 injuries. In a very serious single incident in 1966, a retaining wall collapsed killing 6 people and injuring 16 others. Trench excavation at the toe of the wall was found to be the main cause of the collapse. The study also found that a number of significant landslides in recent years, which resulted in injuries and serious social disruption, were related to trench excavations adjacent to slopes. The details and findings of the study are documented in the Special Project Report SPR 2/2001, GEO (2001).

The GEO/CED study concluded that the risk from trench excavations is not low. A Working Group was therefore formed under the Utilities Technical Liaison Committee (UTLC) of Highways Department to prepare guidelines to promote safe practice for trench excavations. This document presents the recommendations of the Working Group as part of the Government's continuing effort to promote a safe and healthy working environment for all personnel in construction sites and others who may be affected by the works.

2.0 OBJECTIVE AND SCOPE

Trench excavations are carried out principally to allow installation or repair of public utilities, drains and sewers to serve populated areas. The purpose of this Guide is to provide recommendations on good practice of shoring support and drainage measures for trench excavations in order to enhance the safety of the people who may be affected by the excavation works or their collapses. Before a trench is excavated, the designer should bear in mind that the trench support system and associated precautionary measures should be required to serve two purposes:

- (i) stability of the trench itself, and
- (ii) avoidance of any adverse effect on the stability of adjacent slopes and in turn the safety of the public. (“Slopes” in this Guide should be taken to mean man-made slopes, retaining walls or sloping natural ground.)

As determined by the GEO/CED study (GEO, 2001), the collapse of trenches is attributed to inadequate shoring, largely due to non-compliance with contract specifications and statutory requirements. However, one of the major contributory factors in the case of trench-related slope failures was found to be inadequate drainage provisions. In view of the above, this Guide emphasizes the deficiencies identified by the GEO/CED study, i.e. the need for adequate shoring support and drainage measures, and the need to comply strictly with site supervision requirements and site safety inspections. Therefore, the users of this Guide should refer to the relevant documents on other aspects related to the construction safety of trench excavation which are not covered (e.g. confined spaces, electricity supply lines protection, gas safety, site traffic management, etc.). It must also be stressed that the guidelines given in this Guide are in no way exhaustive, and professional judgement must be exercised in all cases.

The Guide is intended to be used by all personnel who are involved in the planning, design, construction and supervision of trench excavation works, including contractors, utility companies, consultants, government departments and any other parties concerned.

3.0 PLANNING STAGE

3.1 Desk Study

When a trench excavation is being planned for any purpose, a thorough search should be made for information about any existing utilities adjacent to or crossing the line of the planned trench, including their sizes, locations and alignments. Most of the underground utilities are live systems, such as electricity, water, sewer and gas, and can be dangerous to workers when damaged or fractured. Particularly for gas, water mains and sewage rising mains, ground movement resulting from excavation may be sufficient to cause these mains to fracture.

If the planned trench is located near slopes, special attention should be paid to the presence of any pressurized water mains as any damage to the pipes could lead to slope failures. It is important to search the Slope Information System via the Hong Kong Slope Safety website (<http://hkss.ced.gov.hk>) to identify any relevant slope information, such as past instability, substandard slopes with outstanding Dangerous Hillside Orders and slopes under the Landslip Preventive Measures Programme. Water Supplies Department (WSD) in their publication on “Guidelines for Excavation near Water Mains” (WSD, 2000) sets out procedures and practices for safe working near water mains. In addition, as required under HyD’s “Conditions of Permit”, utility companies should be consulted for locations of their existing installations in the vicinity of the planned trench prior to commencement of excavation.

Other site conditions should also be assessed. They include traffic loads, vibration of construction plant, condition and stability of adjacent structures, visible evidence of slope instability, groundwater table, any need for special excavation techniques such as dewatering, possibility of flooding by surface run-off, and flooding conditions in the vicinity of the site, etc. Detailed information on flooding blackspots in Hong Kong can be viewed via the Drainage Services Department (DSD) homepage (www.info.gov.hk/dsd).

The permit holders, designers and contractors should familiarize themselves with the relevant Ordinances, Regulations, Codes of Practice and Guides before opening up a trench. A list of useful references is provided in Sections 7.1 and 7.2.

3.2 Timing and Location

Trench excavations without proper drainage provisions that are carried out adjacent to slopes can cause landslides in heavy rain. The Geotechnical Manual for Slopes (GEO, 1984) advises that “... *trenches at the slope crests should not be opened up during the wet season unless unavoidable. If such trenches are to be excavated during the wet season, the trench should be protected against the ingress of runoff from the surface in which the trench is excavated...*”. The required drainage protective measures are discussed in Sections 4.2.2 and 5.2 below.

If the trench excavation is for new utilities, the routing of the utilities should be kept as far away from the crest or toe of a man-made slope as possible. As a general rule, water-carrying buried services should not be placed in a slope nearer to the crest of the slope than a horizontal distance equal to its vertical height. If it is unavoidable to lay water carrying services in the slope crest, measures to minimise possible adverse effects on slope stability given in Section 7 of the Code of Practice on Inspection & Maintenance of Water Carrying Services Affecting Slopes (WB, 1996) should be followed. It is also not desirable to have the whole length of a long trench opened up at any one time, even with support. Excavations should be in sections of shortest practical length, preferably not more than 100 m long.

For sites perceived to be of high risk of flooding or landslide, an emergency plan is required; this may consist of contact telephone numbers and some emergency procedures such as fencing off potentially hazardous areas and provision for pumping out water from trenches. Site staff and full-time workmen, if available, should be made aware of and have access to the emergency plan.

3.3 Statutory Requirements

In accordance with the Land (Miscellaneous Provisions) Ordinance (LMPO), a person shall obtain an excavation permit issued under section 8 of the LMPO in order to make or maintain any excavation in unleased land. Unleased land includes all public roads and pedestrian pavements. Director of Highways is delegated with the power to issue excavation permits for excavations in streets maintained by the Highways Department. For excavations carried out in unleased land other than streets maintained by the Highways Department, Director of Lands is the Authority for issuing the excavation permits.

Application for an excavation permit should be made to the respective regional office of the Highways Department or the District Lands Office. The excavation permit is normally issued to the utility company concerned. The contractor carrying out the works is required to comply with the conditions of the permit to ensure safety of the general public, workers and the works. The utility company concerned, as the permit holder, should also carry out necessary site supervision and inspection to ensure compliance with the conditions by his contractor.

If excavation works are carried out on private land, the works may be subject to the provisions of the Buildings Ordinance. The Practice Note for Authorized Persons and Registered Structural Engineers (PNAP) 148 sets out the requirements for an excavation and lateral support plan under Building (Administration) Regulation 8(1)(bc). The regulation requires that all excavations must be properly designed, and Authorized Persons and Registered Structural Engineers are required to take adequate precautions to ensure public safety. An excavation and lateral support plan is normally required if the excavation is deeper than 4.5 m and greater than 5 m in length.

4.0 DESIGN STAGE

As GEO (2001) shows, the hazards posed to workers working in trenches are potentially fatal. Trench failures can, however, be largely avoided by installing an adequately designed support system. No worker should be permitted to work in an unsupported trench with depth greater than 1.2 m. Other precautions include the avoidance of external load from construction vehicles and excavated spoil being stockpiled too close to the trench.

4.1 Temporary Support Design

For excavation depth of less than 1.2 m, shoring support may not be required for ground that is found to be self-supporting. However, if external loads are likely to be present, or if there is doubt as to the stability of the trench sides due to the presence of weak ground or high groundwater, especially in inclement weather, the trench sides should be supported even if the excavation depth is less than 1.2 m.

For trench excavation with a depth greater than 1.2 m, adequate support must be installed in a timely manner and ahead of excavation as far as is practicable. R39(1) of the Construction Site (Safety) Regulations (Cap. 59I) states : *“The contractor responsible for any construction site at which excavating or earthworking operations are being carried on shall cause a structure made of suitable timber or other suitable material to be erected in connexion with the operations as soon as may be necessary after their commencement so as to prevent workmen employed on the site from being endangered by a fall or displacement of earth, rock, or other material (including waste material and debris) adjacent to or forming the side of the excavation or earthwork.”*

Typical shoring details given in Appendix A may be acceptable for depths up to 4.5 m. Irvine & Smith (1992) also provide some guidance in CIRIA Report 97 on prescriptive design.

However, specific design with detailed working drawings should be prepared for excavations meeting the following criteria:

- (a) deeper than 4.5 m, and greater than 5 m in length, and
- (b) liable to affect any road, building, structure, slope steeper than 30° or water main 75 mm in diameter or greater, the affected area being defined as within the 45° line up from the base of the excavation to the ground surface.

Such design should be carried out by a professionally qualified engineer who is competent in carrying out a proper shoring design. A suitable qualification is Registered Professional Engineer in the Civil, Structural or Geotechnical Discipline. GCO Publication No 1/90 entitled “Review of Design Methods for Excavations” (GCO, 1990) provides guidelines on the design of the support system.

If the design is not carried out by a professionally qualified engineer, the temporary support works, including design, erection, use and removal, should be checked and certified by an independent checking engineer who is competent in carrying out a proper shoring design. A suitable qualification is Registered Professional Engineer in the Civil, Structural or Geotechnical Discipline.

4.2 Design Considerations

4.2.1 Loading

When carrying out the design, consideration should be given to loading imposed on the open trench. The route of the trench should ideally be kept away from any traffic. However, if this cannot be avoided, traffic load should be taken into account in the design of temporary support. The trench support should also be properly designed to take the additional load from any excavated spoil or other construction materials placed along the trench sides.

A trench located at the toe of a slope can greatly reduce the stability of the slope to the extent that it may fail catastrophically, and should be avoided wherever possible. If unavoidable, it is important that the trench support is designed to resist the force to ensure that the stability of the slope will not be adversely affected by the trench work. Stability analysis of the affected slope may also be required.

In the above cases, the employment of a professionally qualified engineer to carry out the design of the temporary support system should be considered even if the trenches are less than 4.5 m deep.

4.2.2 Drainage

Drainage measures to prevent ingress of surface runoff must be provided regardless of the excavation depth. These measures are particularly important to ensure the stability of any man-made or natural slope located below and in the vicinity of the trench excavation works and when the trench is open during any part of the wet season. The possible flooding condition in the area, especially at depression points of roads, should be estimated and considered in the drainage design. The drainage measures are intended to minimise water runoff from the surface into the open trench, and to control infiltration of collected rainwater and runoff from the open trench into the slope; both scenarios are likely to have some adverse effects on the stability of the slope.

To deal with surface runoff, upstands placed along either side of the trench are effective. The upstands are normally made of mass concrete blocks, or in the form of sandbags or compacted earthfill bunds cemented together. The designer/contractor should determine the required height of the upstand depending on site conditions, but in no circumstances should the height be less than 100 mm. Standard details are provided

in Figure B1 of Appendix B. In cases where the trench openings need to be decked over for traffic or pedestrians during works-restricted hours, Figures B2, B3 and B4 of Appendix B must be followed. It is important to ensure the gaps between covers and between ground and cover are sealed. Photos showing some examples of good practice are also given in Appendix B.

4.2.3 Groundwater Control

Where a high ground water table is encountered, the water may be controlled by dewatering. Dewatering may cause the lowering of groundwater in the area around the excavation, which will result in an increase in effective stress of soil and hence settlement of the ground. In cases where there is a concern on the adverse effects of ground settlement near the excavation adjoining sensitive structures, like old buildings on shallow foundations, gas and water mains, busy roads, etc. an assessment of the possible adverse effects of the dewatering is required. The assessment should be carried out by a professionally qualified engineer, and appropriate precautionary measures and monitoring should be designed by him to ensure the safety of the adjoining sensitive structures. Existing guidelines on groundwater drawdown are given in GCO (1990).

4.2.4 Existing Man-Made Slope Features

Where existing man-made slope features, such as cut slopes, fill slopes or masonry retaining walls, etc. are situated at the proximity of the planned trench, the stability condition of the slope features should be examined and taken into consideration in the design. If any slope feature is suspected to be marginally stable and particularly vulnerable to ground movement, precautionary measures should be provided to support the slope feature.

5.0 CONSTRUCTION STAGE

5.1 Installation of Support

Support of trench excavation should be constructed strictly in accordance with the design and contract specifications. In no circumstances should workers be permitted to work in an unsupported trench which is deeper than 1.2 m. Some general guidelines on the requirements of the support installation are given below.

In ground composed of moderately firm to firm soil, vertical trench sides may stand unsupported for a considerable period of time, and hence half timber board support or half sheet pile support may be adequate provided that the groundwater level is below the bottom of the trench. When the ground condition is poor and has little or no “free-standing” time, full timber board support or full sheet pile support should be installed in such a way that the sides of the trench are supported at all times. That is, installation of sheeting, excavation and insertion of walings and struts proceed by stages until the full excavation depth is achieved.

Installation of support ahead of the excavation to the full depth is of advantage where the soil and sheeting sections allow this. Use of sheet piles rather than timber boards makes it possible to drive to full depth ahead of excavation in most ground and to greater depths. This is considered advantageous where the trench is to be constructed in poor ground and where there are few crossing services. Where existing services crossing a trench line are encountered, timber board support should be provided as far as possible to the exposed excavation face surrounding the services. If decking for traffic or pedestrians is not required, support frames should ideally protrude above ground level.

Removal of struts may be required in order to give access during lowering of pipes or equipment, or compaction of backfill. Only the minimum practicable number of struts should be removed. It is important that the ground is adequately supported at all times while workers are working in the trench.

Irvine & Smith (1992) provide guidelines for the installation procedure of temporary support.

5.2 Special Drainage Provisions in the Wet Season

If trench excavation during the wet season and located on or above man-made or natural slopes cannot be avoided, adequate drainage provisions must be provided to ensure that the stability of the slopes will not be adversely affected by any water ingress from the trench.

Rainwater can infiltrate into the slope from an open trench at the slope crest. This can best be avoided by providing upstands on either side of the trench, as discussed in Section 4.2.2. For trenches up to 2 m wide, upstands should be used, together with

preferably rigid trench covers such as fibre-glass or steel covers while work is not proceeding. For wider trenches, the use of tarpaulin sheeting properly secured against strong wind may be more practical. Any voids between the excavated face and the support should be filled with cement mortar to ensure water cannot get in. Photos showing examples of good practice are given in Appendix B.

Pumping from small sumps should always be provided for all trenches located at slope crest, on slopes, or in flooding blackspots, and opened up in the wet season. The sumps should preferably be lined with concrete. It is important that the pumps provided are of sufficient capacity. All pumping machinery can fail, therefore sufficient standby pumps should be provided. A workman should be employed to supervise the maintenance and functioning of pumps. He should carry out spot-checks on the trench, in particular when works are not proceeding and during inclement weather, to ensure the trench is not flooded and the pumps are functioning.

5.3 Backfilling of Trench and Reinstatement

Upon completion of the trench work, the excavated trench must be backfilled with fine fill material in accordance with the specification and standard of Section 6 of the General Specification (GS) for Civil Engineering Works (CED, 1992 or as amended or updated). Loosely compacted trenches will permit lateral flow of water along the trench through the backfilled material. They will also lead to excessive settlement of roads which will damage the road structure and will cause damage to the underlying utilities. Infiltration through cracked pavement into the loose soil can lead to the failure of the adjacent downslopes. To control the compaction, it is good practice to carry out field density tests, using e.g. the sand replacement method.

In reinstating the road surface, the standards given in the GS as well as Highways Standard Drawings must be complied with. The requirements and the quality of the reinstatement works are clearly listed in HyD's booklet "How to apply for an Excavation Permit and how to conduct Excavation Works", and in HyD's "Conditions of Permit".

5.4 Precaution in Use of Machinery

Slopes with loose boulders, rock slopes with loose blocks or sub-vertical masonry or brick facing may be vulnerable to vibration induced by heavy machinery operating in close proximity, such as pneumatic hammers used for trench excavation. It is suggested that heavy machinery should be used with caution, and attention should be paid to any signs of instability or movement, such as loose soil or small pieces of rock falling from slopes, or loose masonry facing blocks. Operation should be stopped immediately when any signs of distress or movement are observed. The operation should not be resumed until the necessary precautionary measures have been implemented, such as provision of wire mesh to the areas with loose rock or raking

shores to the masonry facing. If in doubt, the condition should be assessed by a professionally qualified engineer.

5.5 Other Considerations

If the site conditions permit, construction vehicles and stockpiled materials should be kept at least 1.5 m away from the edge of the trench. However, if this minimum distance cannot be maintained due to space restriction on site, the stability of the trench should be checked in order to ensure no adverse effects would be resulted from the loading imposed due to the close proximity of the construction vehicles and stockpiled materials. Otherwise, the support system should be properly designed to allow for the additional loading. Particular attention should be given to ensuring the safety of construction vehicles working close to the trench edge, especially after heavy rain which may have caused loosening or weakening of the soil behind the trench wall.

The spoil should be placed and covered so as not to be washed into the trench during rainstorms or allowed to enter the surface drainage systems. An open trench should be securely fenced off to prevent accidental fall into the trench.

Ground movement due to trench excavation should be minimized as it can damage existing services running parallel to or across the trench. In addition, when existing services cross a trench line may be undermined by the excavation, they should be supported either by propping from underneath or by hangers suspended from ground surface.

As this Guide concentrates only on aspects relating to shoring support and drainage measures, users of this Guide should refer to the relevant documents on other aspects related to the construction safety of trench excavation.

6.0 SITE SUPERVISION AND SITE SAFETY INSPECTION

The trench excavation works must be closely supervised to ensure compliance with the statutory requirements, permit conditions and contract specifications, including all safety precautions. Many previous failures resulting in casualties or social disruption were likely to have occurred because of non-compliance due to inadequate site supervision. The permit holders, their consultants if employed and contractors all have an important role to play during the construction of the trench excavation works. That is to ensure the safety of the personnel involved in the trench excavation works and the general public who may be affected by the works. The roles and duties of different parties concerned are described in the following paragraphs.

6.1 Site Supervision

A competent person employed by the contractor shall, under the Construction Sites (Safety) Regulations (Cap. 59I), examine every part of the excavation or earthworks at least once a week to ensure compliance with statutory requirements. If so required under the contract, the competent person shall carry out additional duties to ensure compliance with permit conditions and/or contract specifications. In this connection, the competent person should be well familiar with the design and contract specifications. He should also possess at least a higher certificate or higher diploma of any recognized examining body (e.g. the Institutes of Vocational Education) in civil, structural or geotechnical engineering with total relevant experience of not less than three years.

If the depth of the excavation exceeds 1.2 m or the consequence of failure of any slopes affected by the trench excavation is considered significant, the contractor must employ a foreman. The foreman should provide daily full-time supervision when works are in progress to ensure the works are carried out in accordance with specifications and drawings. If a consultant is employed by the client to provide site supervision, a full-time works supervisor must be employed by the consultant to carry out day-to-day supervision of the excavation works. The minimum qualification required of the foreman and works supervisor should be a certificate or diploma holder of any recognized examining body (e.g. the Institutes of Vocational Education) in civil, structural or geotechnical engineering with total relevant experience of not less than two years. For those existing foremen and works supervisors who do not possess the required academic qualifications, a minimum of five years of relevant experience can be considered to meet the required minimum qualification.

In the case where the trench meets the criteria set out in Section 4.1, a professionally qualified engineer is required to carry out the design. The engineer should make periodic inspections to check that the design assumptions are valid and that works are being carried out in accordance with the design.

The site foreman, competent person and works supervisor must also inspect the adjacent structures, utilities, roads and slopes so that any signs of movement or distress can be detected at the earliest possible opportunity. Any necessary precaution and emergency measures must be carried out immediately to ensure the safety of the site personnel and the general public. They should pay special attention to the drainage provisions if the trench excavation is located on or above any slopes and is being carried out in the wet season. They should also inspect and document the conditions of the trench after each severe rainstorm if it is adjacent to slopes and arrange for necessary precautionary measures, such as pumping out of any standing water. Inspection records of the full-time foremen, supervisors and competent persons should be made available for inspection by representatives of the relevant Authorities.

6.2 Site Safety Inspection

Apart from the daily on-site supervision by the contractors and the consultants if employed, the project proponents, client Departments or utility undertakings concerned should arrange inspections of trench excavation works sites as and when necessary in order to check that all statutory requirements, permit conditions and contract specifications related to safety measures are in place. Any non-conformities identified during site safety inspection should be documented and brought to the attention of the relevant parties for immediate rectification.

6.3 Safety Checklist for Supervisors

This is a basic checklist for site supervisory staff who have a key role in ensuring compliance with statutory requirements, permit conditions and contract specifications. Other items should be added or items can be marked as not applicable as appropriate to suit particular trench works. For example, if the shoring design has already allowed for the loading from construction vehicles and stockpiled materials placed within 1.5 m from the edge of the trench, Item (i) of the checklist may be marked as not applicable. In cases where non-compliance is observed, the supervisor should investigate whether the variations are permissible. If variations are confirmed to be not permissible, all works should be suspended until appropriate steps have been taken to rectify the situation. The site supervisory staff should fill in and sign the checklist, and should list those steps, if any, that have been taken to rectify the situation in the checklist for record purposes.

- (i) Construction vehicles, excavated spoil, materials, etc. are being kept at least 1.5 m away from the edge of the excavation.
- (ii) Spoil heaps are being properly placed and covered, and will be kept sheltered in wet weather, or will be removed for maintaining access for pedestrians and traffic.

- (iii) Necessary arrangements (e.g. stop boards) are made to prevent vehicles driving into the excavation.
- (iv) Adequate safe access to and egress from any trench is being provided and properly maintained.
- (v) The open trench is properly lit and fenced off in accordance with Code of Practice for the Lighting, Signing and Guarding of Road Works (HyD, current version).
- (vi) The location of any buried services has been identified and clearly marked.
- (vii) Crossing services are properly supported.
- (viii) Trenches are being supported according to the design and contract specifications.
- (ix) The workers are working at safe distances from each other.
- (x) The assumptions used in the design are still valid.
- (xi) There is no movement or deterioration of the ground that may put adjacent services, roads, structures or slopes at risk.
- (xii) The area is unaffected by vibration induced by the operation of heavy machinery.
- (xiii) The ground water level is as used in the design (i.e. not higher).
- (xiv) The work is being done in accordance with the specifications/drawings. If not, is the variation permissible?
- (xv) Unsupported trench faces are safe, with no sign of peeling away, progressive collapse, etc.
- (xvi) The method of withdrawing support during backfilling is safe.
- (xvii) Backfill material is being properly compacted.

6.3.1 Drainage Provisions (particularly important for trench excavations above man-made slopes, retaining walls or sloping natural ground in the wet season)

- (xviii) Flooding is not observed in excavations.

- (xix) There are proper sumps.
- (xx) There are adequate working and stand-by pumps of sufficient capacity on site.
- (xxi) Upstands along either side of the trench are provided.
- (xxii) Gaps/voids between support and the vertical trench sides are filled.
- (xxiii) The open trench is being securely covered when work is not in progress.
- (xxiv) A full-time watchman is making frequent spot-checks during rainstorms.

7.0 REFERENCES

7.1 List of publications referred to in the Guide:

- BD (1993). *Requirements for an Excavation and Lateral Support Plan Building (Administration) Regulation 8(1)(bc)*. Practice Note for Authorized Persons and Registered Structural Engineers (PNAP) 148. Building Authority, Hong Kong.
- CED (1992). *General Specification for Civil Engineering Works. (1992 Edition)*. Civil Engineering Department, Hong Kong. (Amended from time to time).
- Irvine & Smith (1992). *Trenching Practice. (Second Edition)*. Construction Industry Research and Information Association CIRIA Report 97, UK, 64p.
- GCO (1984). *Geotechnical Manual for Slopes. (Second Edition)*. Geotechnical Control Office, Hong Kong, 295p.
- GCO (1990). *Review of Design Methods for Excavations*. GCO Publication No. 1/90, Geotechnical Control Office, Hong Kong, 192p.
- GEO (2001). *A Study on Past Failures of Trench Excavations*. Special Project Report SPR 2/2001. Geotechnical Engineering Office, the Government of the HKSAR, 68p.
- HyD *Code of Practice for the Lighting, Signing and Guarding of Road Works*. Highways Department (www.hyd.gov.hk), the Government of the HKSAR. (Current version).
- HyD *How to apply for an Excavation Permit and how to conduct Excavation Works*. Highways Department (www.hyd.gov.hk), the Government of the HKSAR. (Current version).
- HyD *HyD Standard Drawings*. Highways Department (www.hyd.gov.hk), the Government of the HKSAR. (Current version).
- HyD *Conditions of Permit*. Highways Department, the Government of the HKSAR. (Current version).
- Factories and Industrial Undertakings Ordinance (Cap. 59). *Chapter 59I "Construction Sites (Safety) Regulations", Regulation 39 "Safety of excavations, etc"*. Version date : 30/06/1997. Laws of Hong Kong (www.justice.gov.hk), the Government of the HKSAR.
- Land (Miscellaneous Provisions) Ordinance (Cap 28). *Chapter 28, Section 8 "Control of excavations in unleased land"*. Version date : 01/07/1997. Laws of Hong Kong (www.justice.gov.hk), the Government of the HKSAR.

Works Branch (1996). *Code of Practice on Inspection & Maintenance of Water Carrying Services Affecting Slopes*. Works Branch, Government Secretariat, Hong Kong, 54p.

WSD (2000). *Guidelines for Excavation near Water Mains*. Water Supplies Department, the Government of the HKSAR, 15p.

7.2 List of relevant publications not referred to in this Guide:

Construction Site Safety Handbook for Public Works Programme. Works Bureau, the Government of the HKSAR, 2000.

Electricity Ordinance (Cap. 406). *Chapter 406H "Electricity Supply Lines (Protection) Regulation"*. Laws of Hong Kong (www.justice.gov.hk), the Government of the HKSAR.

Factories and Industrial Undertakings Ordinance (Cap. 59). *Chapter 59B "Factories and Industrial Undertakings (Confined Spaces) Regulations"*. Laws of Hong Kong (www.justice.gov.hk), the Government of the HKSAR.

Gas Ordinance (Cap. 51). *Chapter 51B "Gas Safety (Gas Supply) Regulations"*. Laws of Hong Kong (www.justice.gov.hk), the Government of the HKSAR.

Guide to Slope Maintenance. Geoguide 5. Geotechnical Engineering Office, Civil Engineering Department, the Government of the HKSAR, Second Edition, 1998.

Guidance Notes on Audit Inspection of Utility Sites. Highways Department (www.hyd.gov.hk), the Government of the HKSAR.

APPENDIX A : TYPICAL SHORING ARRANGEMENTS

	Page No.	
Figure A1	Typical arrangement of half timber board shoring system	22
Figure A2	Typical arrangement of full timber board shoring system	23
Figure A3	Typical arrangement of sheet pile shoring system with timber struts and walings	24
Figure A4	Typical sheet pile shoring detail with steel struts and walings	25
Figure A5	Typical shoring detail for cable trench	26
Figure A6	Typical arrangement of timber support in areas surrounding existing crossing services	27
Figure A7	Typical arrangement of sheet pile shoring system with timber support in areas surrounding existing crossing services	28
Plate A1	Timber support with one layer of struts for shallow depth of excavation	29
Plate A2	Timber support with two layers of struts	29
Plate A3	Timber support for deeper excavation	30
Plate A4	Steel sheet pile support	30
Plate A5	Steel sheet pile support	31
Plate A6	Timber support provided in areas surrounding existing crossing services	31
Plate A7	Timber support provided in areas surrounding existing crossing services	32
Plate A8	Timber support provided in areas surrounding existing crossing services	32
Plate A9	Installation of support from outside the trench	33

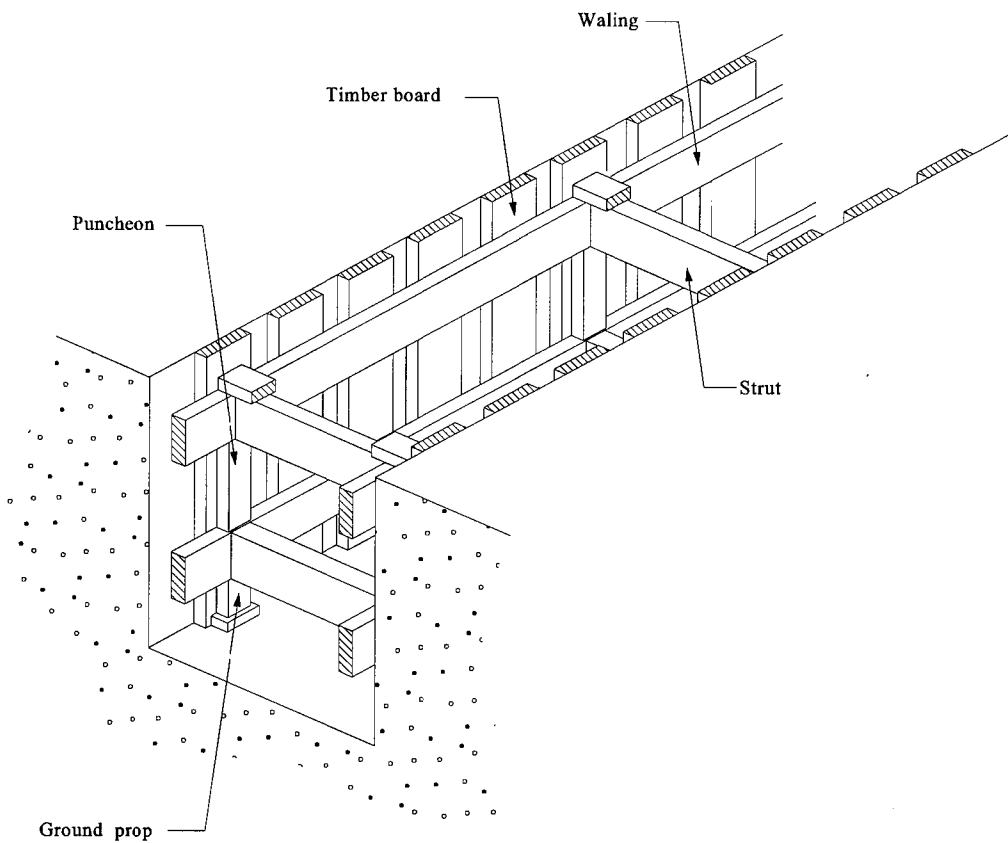

- Notes:
1. The sizes of the structural members (eg. timber boards, struts and walings) and the spacings between struts depend on the actual excavation depth, ground conditions and other factors affecting the loading on the shoring system.
 2. Half timber board shoring may be adequate for moderately firm to firm soil provided that the groundwater level is below the bottom of the trench.

Figure A1 - Typical arrangement of half timber board shoring system

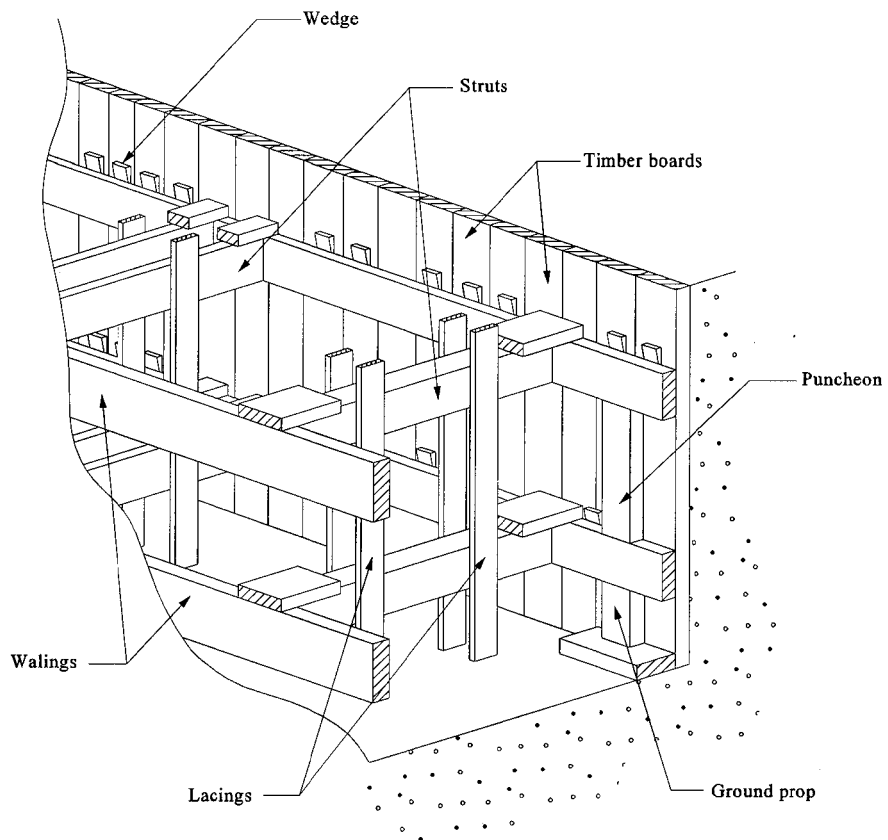

Note: The sizes of the structural members (eg. timber boards, struts and walings) and the spacings between struts depend on the actual excavation depth, ground conditions and other factors affecting the loading on the shoring system.

Figure A2 - Typical arrangement of full timber board shoring system

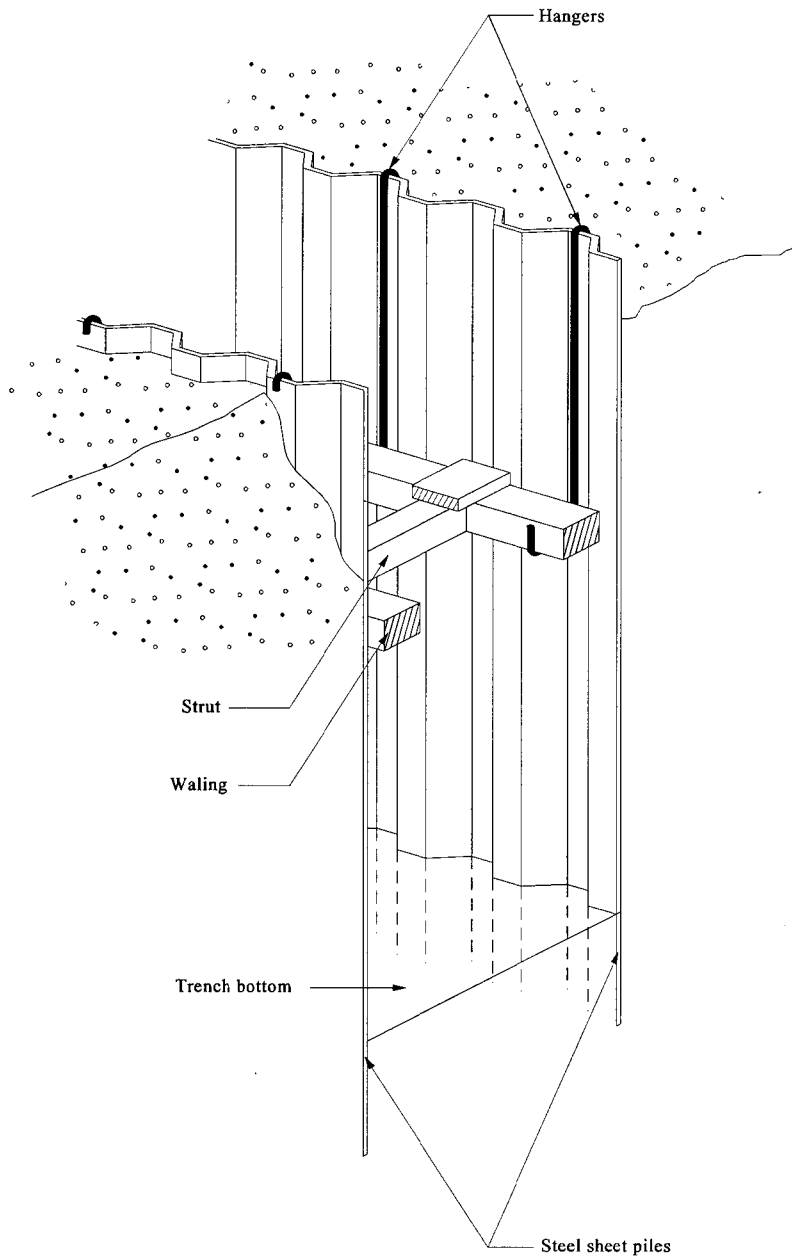

Note: The sizes of the structural members (e.g. sheet piles, struts and walings) and the spacings between struts depend on the actual excavation depth, ground conditions and other factors affecting the loading on the shoring system.

Figure A3 - Typical arrangement of sheet pile shoring system with timber struts and walings

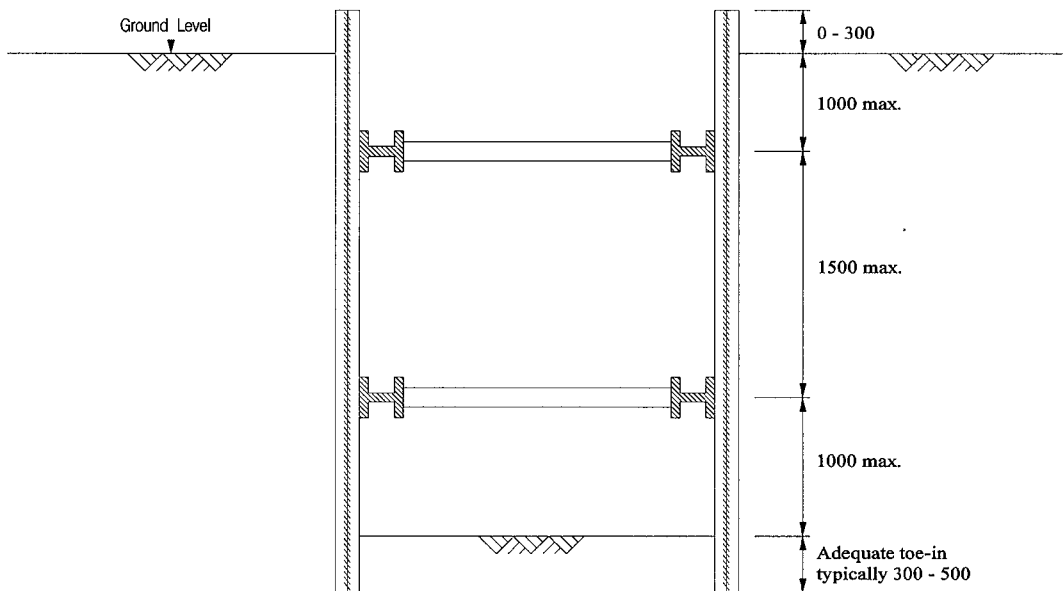

- Notes:
1. All dimensions are in millimeters.
 2. The sizes of the structural members (e.g. sheet piles, strut and walings) and the spacings between struts depend on the actual excavation depth, ground conditions and other factors affecting the loading on the shoring system.

Figure A4 - Typical sheet pile shoring detail with steel struts and walings

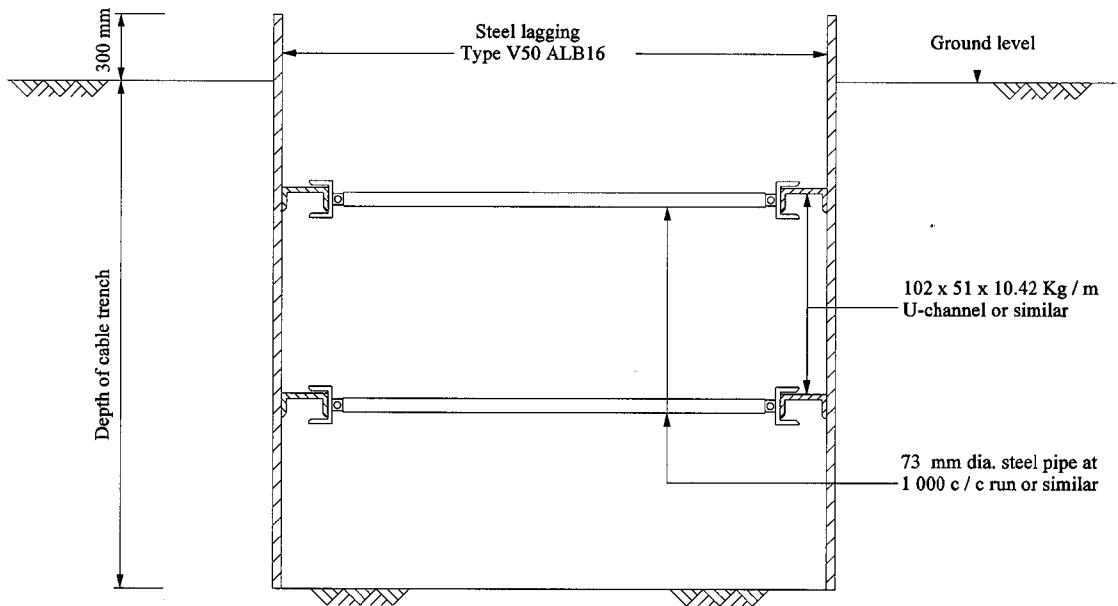

Note: Typical excavation depths for cable trenches are between 1m and 2m.

Figure A5 - Typical shoring detail for cable trench

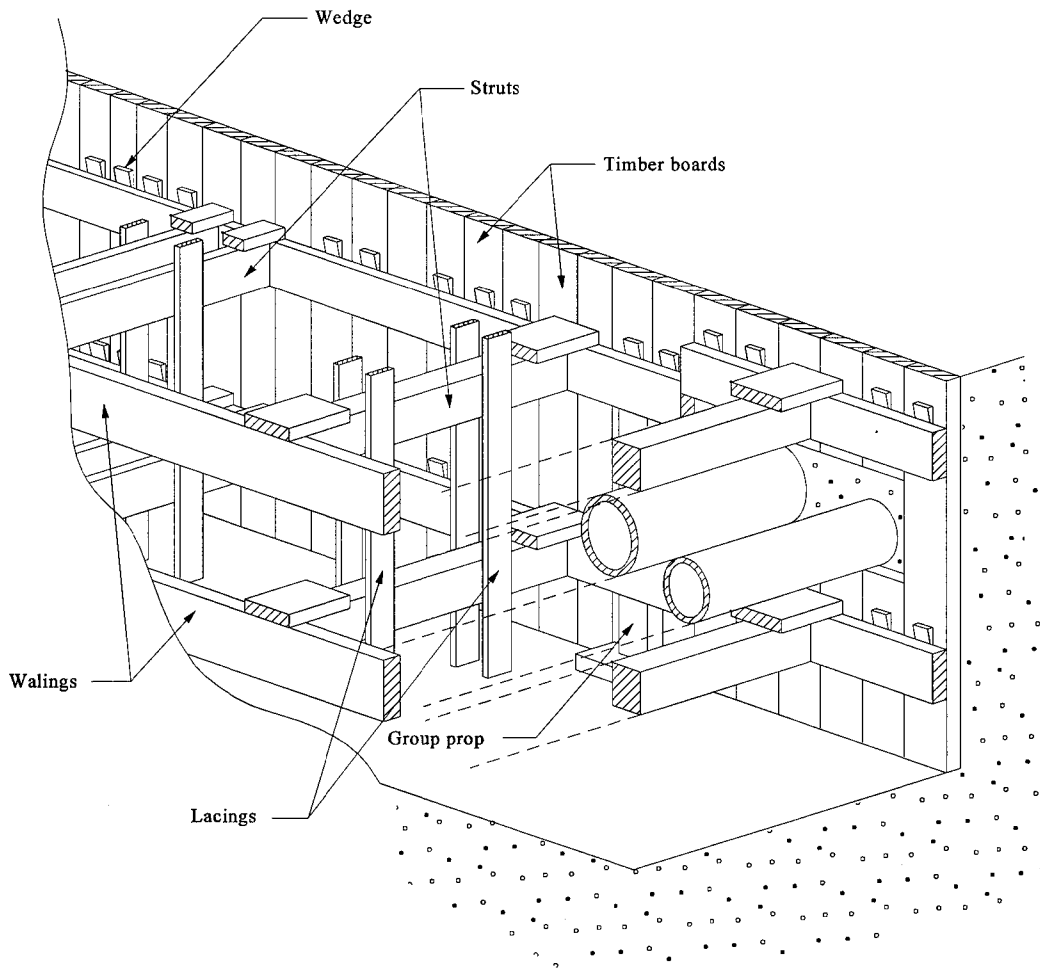

Note: The sizes of the structural members (e.g. timber boards, struts and walings) and the spacings between struts depend on the actual excavation depth, ground conditions and other factors affecting the loading on the shoring system.

Figure A6 - Typical arrangement of timber support in areas surrounding existing crossing services

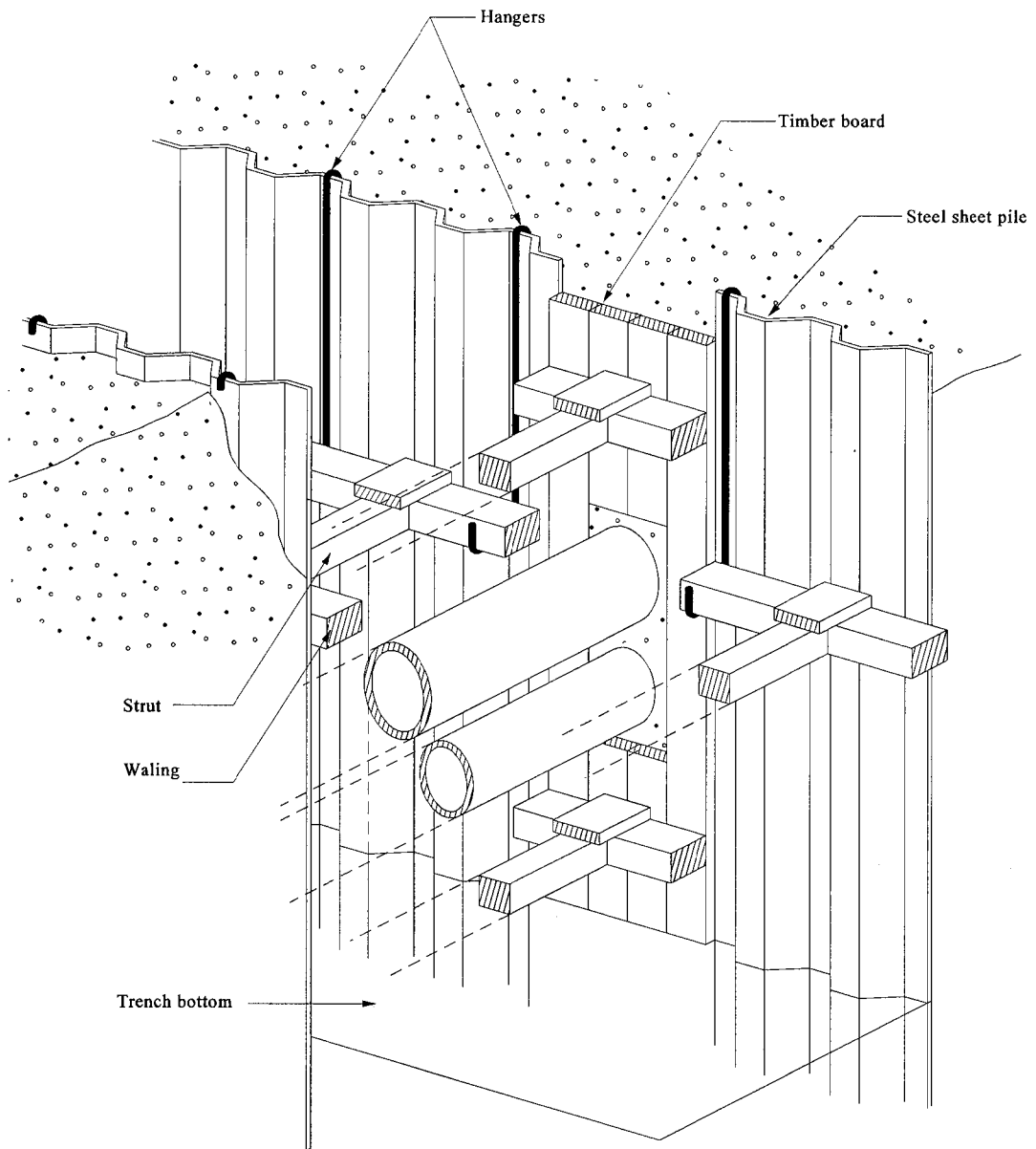

Note: The sizes of the structural members (e.g. sheet piles, struts and walings) and the spacings between struts depend on the actual excavation depth, ground conditions and other factors affecting the loading on the shoring system.

Figure A7 - Typical arrangement of sheet pile shoring system with timber support in areas surrounding existing crossing services



Plate A1 – Timber support with one layer of struts for shallow depth of excavation



Plate A2 – Timber support with two layers of struts



Plate A3 – Timber support for deeper excavation



Plate A4 – Steel sheet pile support



Plate A5 – Steel sheet pile support



Plate A6 – Timber support provided in areas surrounding existing crossing services



Plate A7 – Timber support provided in areas surrounding existing crossing services



Plate A8 – Timber support provided in areas surrounding existing crossing services



Plate A9 – Installation of support from outside the trench

APPENDIX B : RECOMMENDED DRAINAGE MEASURES

	Page No.	
Figure B1	Suggested measures to prevent rainwater and surface runoff entering the trench	35
Figure B2	Typical vehicle crossing over trench opening for flexible pavement (Flush with road surface). (Reproduced from Highways Department Drawing No. H 6135A)	36
Figure B3	Typical vehicle crossing over trench opening for rigid pavement. (Reproduced from Highways Department Drawing No. H 6136A)	37
Figure B4	Typical arrangement of temporary pedestrian crossing over trench not exceeding 2000mm wide. (Reproduced from Highways Department Drawing No. H 1132)	38
Plate B1	Typical vehicle crossing over trench opening which is also effective for preventing surface runoff and infiltration of rainwater	39
Plate B2	Typical pedestrian crossing over trench opening which is also effective for preventing surface runoff and infiltration of rainwater	39
Plate B3	Sandbag upstand with fibre-glass cover to prevent surface runoff and infiltration of rainwater	40
Plate B4	Sheet piles protruding above ground with cement mortar wedge applied to prevent surface runoff	40
Plate B5	Timber support protruding above ground with cement mortar wedge applied to prevent surface runoff	41
Plate B6	Pumping provided	41
Plate B7	Tarpaulin cover secured against wind for wider trenches	42
Plate B8	Tarpaulin cover secured against wind for wider trenches	42

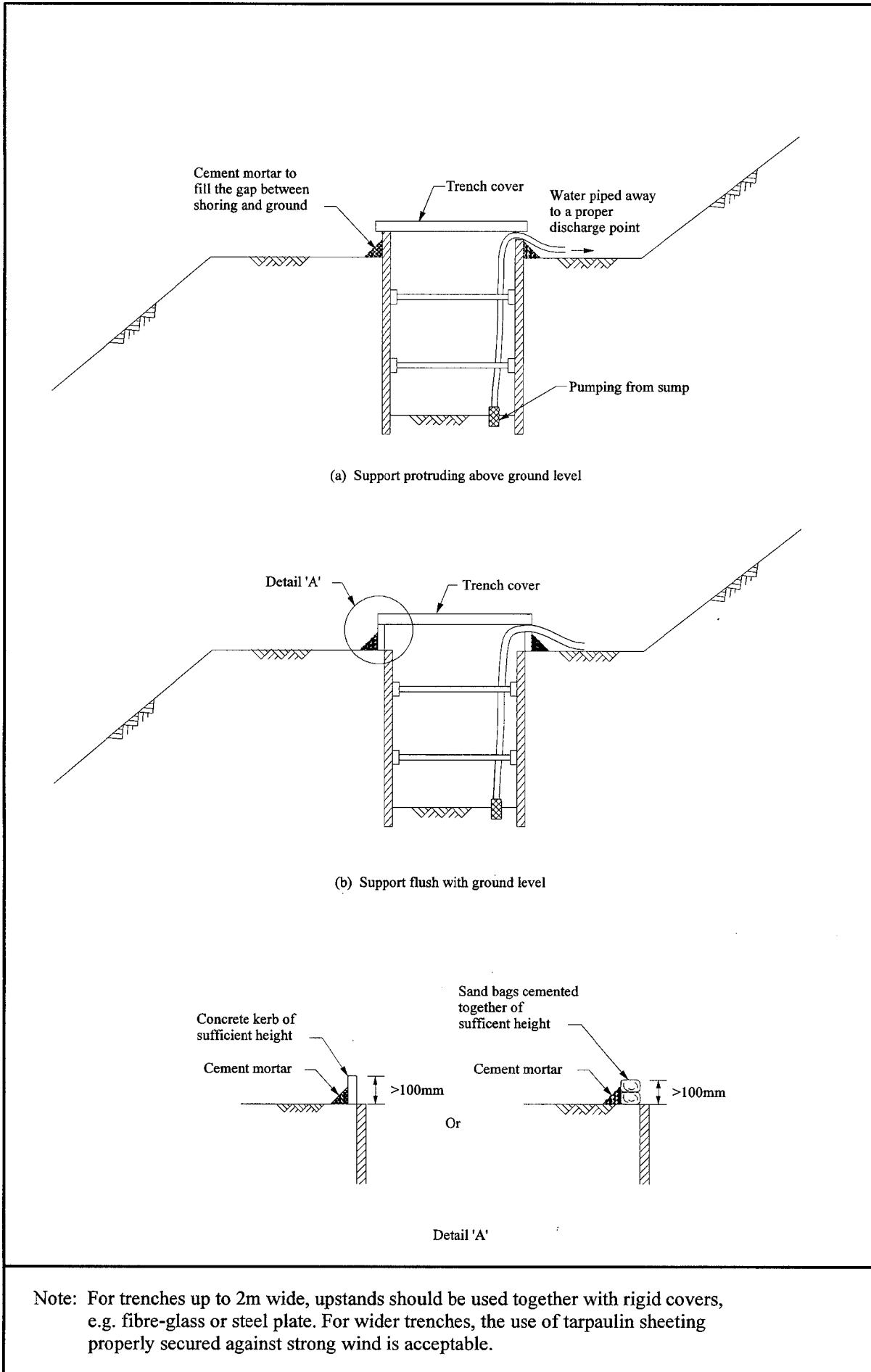

Figure B1 - Suggested measures to prevent rainwater and surface runoff entering the trench

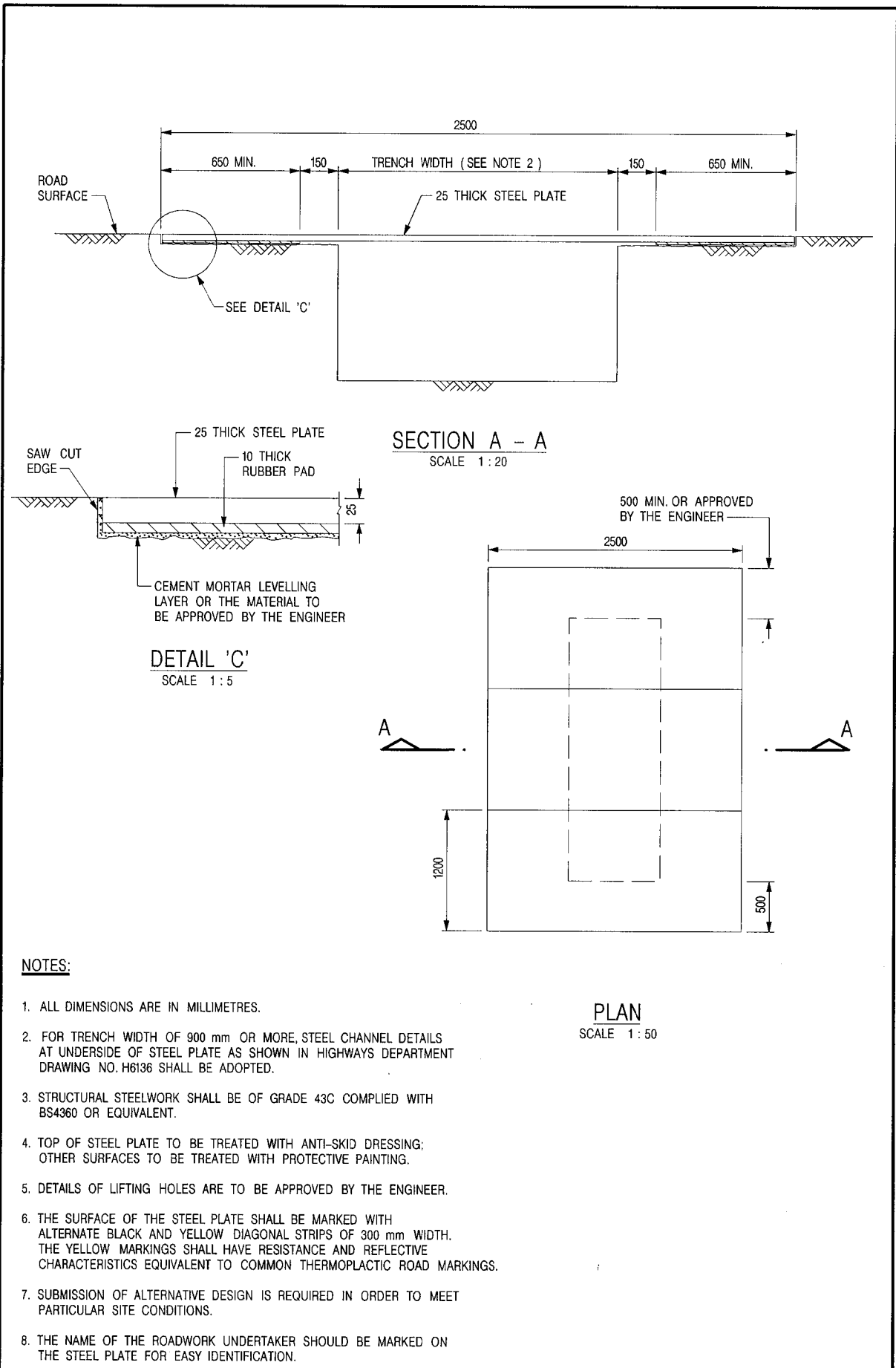
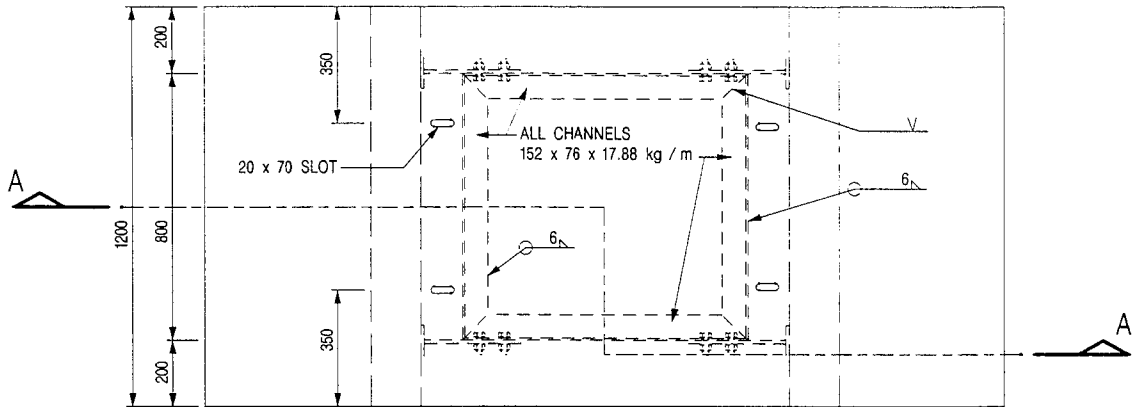
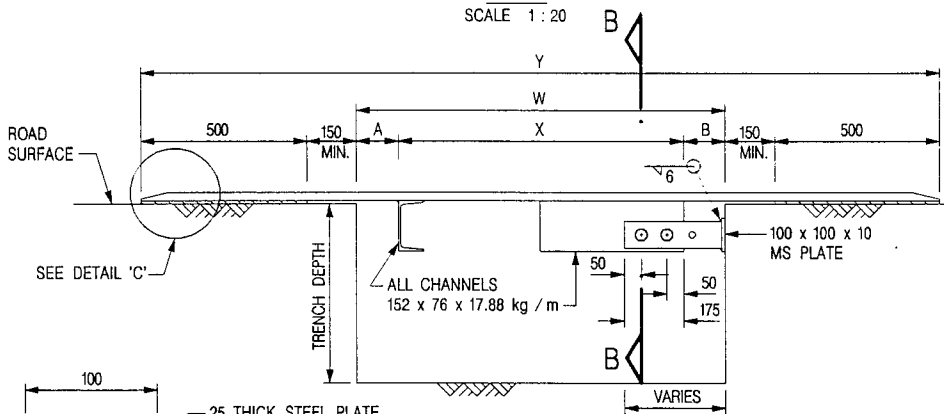

Figure B2 - Typical vehicle crossing over trench opening for flexible pavement (Flush with road surface) (Reproduced from Highways Department Drawing No. H6135A)



PLAN
SCALE 1 : 20



SECTION A - A
SCALE 1 : 20

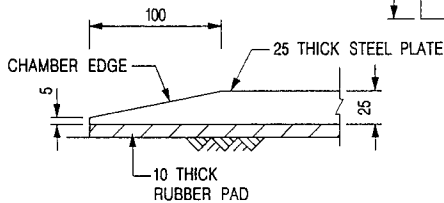

DETAIL 'C'
SCALE 1 : 5

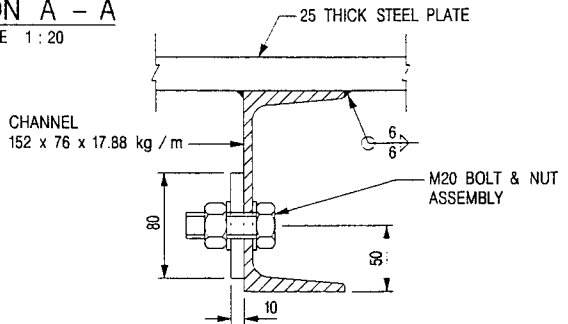

SECTION B - B
SCALE 1 : 5

NOTES:

1. ALL DIMENSIONS ARE IN MILLIMETRES.
2. STRUCTURAL STEELWORK SHALL BE OF GRADE 43C COMPLIED WITH BS4360 OR EQUIVALENT.
3. ALL FILLET WELDS TO BE 6 mm UNLESS OTHERWISE SPECIFIED.
4. TOP OF STEEL PLATE TO BE TREATED WITH ANTI-SKID DRESSING; OTHER SURFACES TO BE TREATED WITH PROTECTIVE PAINTING.
5. WELDING BETWEEN CHANNELS TO BE FULL PENETRATION WELD.
6. DESIGN TO BE ACCORDING TO BS5400.
7. OTHER DETAILS OF LIFTING HOLES ARE TO BE APPROVED BY THE ENGINEER.
8. THE SURFACE OF THE STEEL PLATE SHALL BE MARKED WITH ALTERNATE BLACK AND YELLOW DIAGONAL STRIPS OF 300 mm WIDTH. THE YELLOW MARKINGS SHALL HAVE RESISTANCE AND REFLECTIVE CHARACTERISTICS EQUIVALENT TO COMMON THERMOPLASTIC ROAD MARKINGS.
9. SUBMISSION OF ALTERNATIVE DESIGN IS REQUIRED IN ORDER TO MEET PARTICULAR SITE CONDITIONS.
10. THE NAME OF THE ROADWORK UNDERTAKER SHOULD BE MARKED ON THE STEEL PLATE FOR EASY IDENTIFICATION.

TYPE	W (TRENCH WIDTH)	X	Y	A OR B MAX
A	500 TO < 900	450	2200	225
B	900 TO < 1200	850	2500	175
C	1200 TO < 1400	1150	2700	125

Figure B3 - Typical vehicle crossing over trench opening for rigid pavement
(Reproduced from Highways Department Drawing No. H6136A)

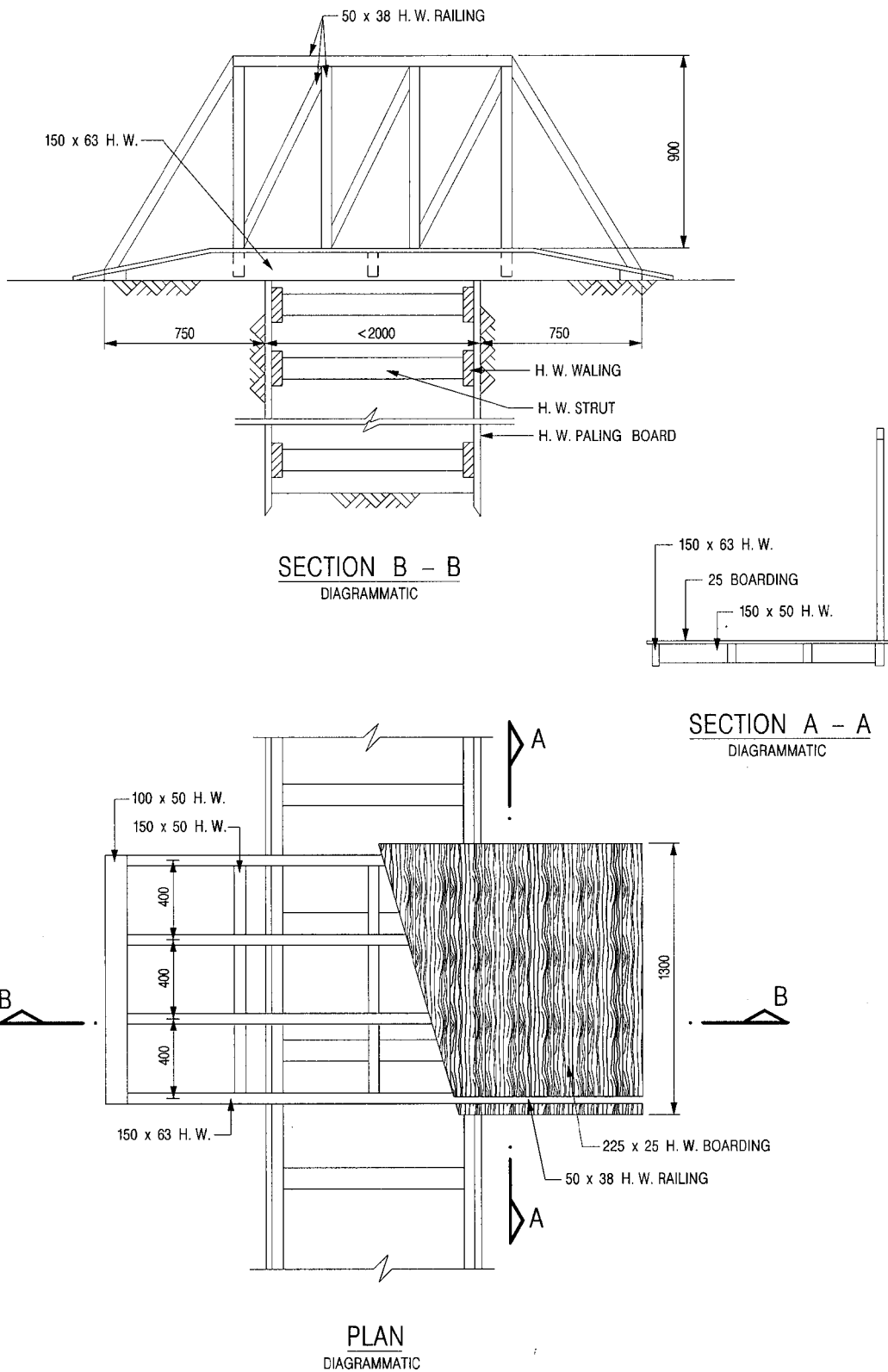

NOTES:

1. ALL DIMENSIONS ARE IN MILLIMETRES.
2. PORTION OF TRENCH SHOULD BE STRUTTED FOR AT LEAST 900 BOTH SIDES OF BRIDGE CROSSING.

Figure B4 - Typical arrangement of temporary pedestrian crossing over trench not exceeding 2000mm wide (Reproduced from Highways Department Drawing No. H1132)



Plate B1 – Typical vehicle crossing over trench opening which is also effective for preventing surface runoff and infiltration of rainwater



Plate B2 – Typical pedestrian crossing trench opening which is also effective for preventing surface runoff and infiltration of rainwater



Plate B3 – Sandbag upstand with fibre-glass cover to prevent surface runoff and infiltration of rainwater



Plate B4 – Sheet piles protruding above ground with cement mortar wedge applied to prevent surface runoff



Plate B5 – Timber support protruding above ground with cement mortar wedge applied to prevent surface runoff



Plate B6 – Pumping provided



Plate B7 – Tarpaulin cover secured against wind for wider trenches



Plate B8 – Tarpaulin cover secured against wind for wider trenches