



**GOVERNMENT OF INDIA**  
भारत सरकार  
**MINISTRY OF RAILWAYS**  
रेल मंत्रालय

# **Guidelines and Specifications for Design of Formation for Heavy Axle Load**

**Report No. RDSO/2007/GE : 0014**

November 2009

---

**Geo-technical Engineering Directorate**  
भू-तकनीकी इंजीनियरी निदेशालय  
**Research Designs & Standards Organisation**  
अनुसंधान अभिकल्प और मानक संगठन  
**Lucknow – 226011**  
लखनऊ – 226011

---

**INDEX**

<b>S. No.</b>	<b>Contents</b>	<b>Page</b>
	Foreword	4
	Preface	5
1.	Introduction	7
2.	Definitions	7
3.	Formation Components	8
4.	Soil Exploration and Survey	9
5.	Aspects of Designing subsoil, Embankment and Track Subgrade	11
6.	Functions of Blanket Layer	18
7.	Historical Development on Blanket Layer	19
8.	Existing Provisions of Blanket & Formation On Indian Railways	20
9.	Provisions of Blanket in other Railway Systems	22
10.	Design Methods/Practice in World Railway Systems	22
11.	Design of Formation for 25, 30 & 32.5 T axle load on the basis of different methods	26
12.	Recommended Specifications Of Blanket Material	27
13.	Qualifying and Quality Assurance Tests	28
14.	Ground Improvement Methods	29
15.	Discussions on Formation Layers System	30
16.	Formation of Review Committee & Railway Board's approval	31
17.	Specifications & Recommendations	32
18.	Other Important Guidelines	39
19.	Bibliography and References	40
	Annexure-1 : Ground Improvements Methods	41
	Annexure-2 : Quality Assurance Tests	48
	Annexure-3 : Formation Stresses - Finite Element Analysis	56
	Annexure-4 : Geosynthetics in Track bed Applications	59
	Appendix-A : Codal Provisions of Track Bed Layers on World Railway Systems	62
	Appendix-B: Minutes of the Special Committee Meeting on 8 & 9.10.2009 at Mumbai & Railway Board letter of approval of the Guidelines	66
	Appendix-C : Mechanical Production of Blanket Material	69

**List of Figures :**

<b>S. No.</b>	<b>Figure No.</b>	<b>Description</b>	<b>Page No.</b>
1	Fig. 1	Typical Cross-section representing Formation Components	8
2	Fig. 2	Deformation of the subsoil and embankment fill	12
3	Fig. 3	Pressure due to Formation on Ground Soil Layer	12
4	Fig. 4	Wheel Load and Pressure Distribution through Formation.	13
5	Fig. 5	Open Longitudinal Drain at Toe of Formation.	15
6	Fig. 6	Sub-soil Longitudinal Drainage System.	15
7	Fig. 7	Sub-grade progressive shear failure	23
8	Fig. 8	Excessive Sub grade Plastic Deformation (Ballast Pocket)	24
9	Fig. 9	Enveloping Curves for Blanket Material	28
10	Fig. 10	Recommended Formation Profiles and Layers for Heavy Axle Load	35-36
11	Fig. 11	Bar Diagrams Showing Formation Layers Thickness	37-38

**List of Tables :**

<b>S. No.</b>	<b>Table No.</b>	<b>Description</b>	<b>Page No.</b>
1	Table 1	Typical Values of Soil Types	17
2	Table 2	UIC Based Two Layers System of Blanketing On Track Formation	26
3	Table 3	Description of Soil Quality Class	26
4	Table 4	Calculation of Blanket Thickness (in cm) For different Axle loads & CBR of soil	27
5	Table 5	Grading Percentage of Blanket Material	28
6	Table 6	Specification and thickness of subgrade layers for Heavier Axle Loads –Recommended Guidelines	33-34

## **Foreword**

Indian Railways is increasing its throughput to cater demand of growing traffic. Heavy Axle Load ( $CC+8+2$  loading on BOXN) has been introduced on many identified routes to increase freight transportation. Furthermore, Dedicated Freight Corridors are to be constructed very soon which is being planned to higher axle load of 25t/32.5t. Feeder routes to these Freight Corridors are also to be strengthened for 25t axle load.

Formation plays key role in good performance of track and yielding formation becomes a bottleneck in running of traffic to its full potential. Future formations need to be designed and constructed for sufficiently heavier axle load which is likely to operate on the line in distant future. RDSO & Special Committee has prepared a document containing Guidelines & Specification of formation components designed for heavier axle loads introducing the latest features available around the world on this subject. I am sure that implementation of these guidelines and formation specification will result in stable and good quality formations suitable for running of heavier axle loads. These guidelines should be put to use only on new works and would not apply to ongoing projects. This may be first tried out for a year and half to get the field appreciation and correction required, if any.

It is expected that these Guidelines will enable Engineers on Indian Railways to achieve quality in execution of earthworks for heavier axle loads.

**(Rakesh Chopra)**  
*Member Engineering*  
Railway Board

November 2009, New Delhi

## **PREFACE**

Indian Railways (IR) has now stabilised running of axle loads upto 22.8 tons(t) (commonly referred to as *CC+8+2 t* loading on IR in context of payload for BOXN) on Heavy Density Network (HDN) routes and plan to construct 'Dedicated Freight Corridors (DFC)' with substructure designed for heavy axle loads ( 25t/ 32.5t). Feeder routes to the DFCs are also proposed to be strengthened/ constructed for 25 tons axle loads.

Formation provides the *base* for track structure. Hence, formation with provision of blanket layer on top and underlying subgrade layers of adequate strength is essential to be provided with a *rationale* criterion for safe operations of heavy axle loads.

The existing instructions available on the subject in various Guidelines issued by RDSO earlier, has been implied generally with axle loads upto 22.5t. The provisions for blanket thickness, as per 'Guidelines For Earthwork in Railway Projects', NO. GE:G-1, July 2003 are applicable upto 22.5t, and is based on soil classification of underlying layers. These provisions are now required to be reviewed and based on firm theoretical consideration for heavy axle loads 25t to 32.5t, keeping in view World Railway practices.

Railway Board vide letters no.2007/CE-I/Geotech/02 dated 22.10.2007, 20.3.2008, 08.5.2008 & 09.3.2009 have interacted and guided RDSO in formulation of the *Guidelines* for design of formation for Heavy Axle Load for 25t, 30t & 32.5t on *rationale* basis.

This *Guideline* outlines the key components on sub-grade and formation design issues, reviews the design methodologies adopted on various World Railway systems, e.g. American Railways, European Railways, Australian Railways, covers in brief a few design methods available with calculations done for different axle load and soil conditions.

This *Guideline*, based on strength criteria considering *CBR* value of subgrade layer, recommends Specifications & thickness of two alternative systems of Formation layers, viz. (i) a conventional single blanket layer system over embankment fill, (ii) two layer system comprising of blanket and prepared subgrade layer over the normal fill layers. Both the two alternate systems have been specified for 25T, 30T & 32.5T axle loads cases.

Concept of *CBR* based value for subgrade soil selection has been incorporated on the pattern of Highways design, as given in Code IRC:37 "Design of Flexible Pavements'. Concept of Elastic modulus of compacted layer ( $EV_2$ ) determined from second loading in Plate Load Test has been introduced as a quality assurance test similar in UIC railways. The Guidelines also includes special features like ground improvement methods, quality assurance tests and important considerations to be kept in view for construction of good quality formation suitable for running of heavy axle loads.

The proposed thickness & specifications of blanket material, subgrade layers along with design methodology of formation design for axle loads 25t to 32.5t shall provide a fillup for present formation design adoption on Dedicated Fright Corridor Routes, Feeder Routes and new construction of HDN routes on IR.

Keeping in view of proposed running of heavy axle loads of 25T & 32.5T for DFCs, *draft* 'Specification of Formation for Heavy Axle Loads', May 2008 were circulated to Zonal Railways for suggestions/comments. These *draft* Specifications

have received favourable response from Zonal Railways and found acceptance in various other forums like IPWE Seminar, TSC meetings, PCE & CAO/C Conference, etc.

It is expected that these *Guidelines* will enable Engineers on Indian Railways to achieve appropriate *fit for purpose* design and quality in execution of earthworks for heavy axle loads.

This document has evolved over last 16 months based on continued efforts by Geotechnical Directorate, RDSO under technical guidance of Railway Board, notable being the directions given by Patrons- Shri Rakesh Chopra, Member Engineering, Railway Board, Shri S.K. Vij, ex-M.E., Shri S.K. Mallik, Advisor (CE), and Shri Deepak Krishna, ex-Additional Member(CE) now General Manager, Eastern Railways.

Technical guidance and support has been continuously extended by Sh. Jogesh Singh Sondhi, ED CE(B&S)-II, Railway Board for content and layout review, adoption of *CBR* based strength system for track subgrade design based on other International Projects experience.

Vide Railway Board letter no. 2007/CE-1/Geotech/02 dated 06.08.2009, a Special Committee was nominated to deliberate upon draft 'Guidelines and Specifications for Formation of Heavy Axle Load', July 2009 with the term of references as cost aspects and material availability and suggestions for new lines/doubling/Gauge Conversion for axle loads in range of 22.5t to 25t. The committee consists of :

1. CAO(C)/WR – Presiding Officer
2. Sr. EDGE/RDSO, Convener Member
3. CAO(C)/NCR – Member
4. CAO(C)/SR – Member
5. Representative from RVNL – Member

The committee deliberated on the draft Guidelines and submitted its recommendations on 09.10.2009. The present documents has been finalised based on the approved recommendations by the Railway Board letter no. 2007/CE-I/Geotech/02 dated 26.10.2009.

Following officers of RDSO have contributed significantly in preparation of this *Guideline*:

1. Shri J.C.Parihar, Sr. Executive Director/Geotechnical, RDSO
2. Shri A. K. Singhal, Executive Director/Geotechnical, RDSO (from Jan 08–Oct 08)
3. Shri Rajesh Agarwal, Director/Geotechnical, RDSO
4. Shri S K Awasthi, Assistant Research Engineer/Geotechnical, RDSO

Specifications of Blanket Material (Para 12), Qualifying and Quality Assurance Tests (Para 13) and Recommendations (Para 17) are of the nature of '**Specifications**' and these are **mandatory** for adoption in field.

**(J.C.Parihar)**

Sr. Executive Director/Geo-technical Engineering  
Research Designs And Standards Organisation, Lucknow

## 1.0 INTRODUCTION

Over the years, increase in traffic and speeds have placed a greater demand on conventional ballasted track. Most of the routes constructed on Indian Railways, earlier provided for lower axle load traffic ( 20t to 22.5t), have now been subjected to increased axle loads.

Improvement of the track system has been mainly to track superstructure, i.e. rails, sleepers, fastening etc. Track sub-structure below ballast has received relatively less attention. Use of poor subgrade soil material has resulted in quite a few sections on Indian Railways being under speed restrictions, resulting in costly maintenance. Provision of granular layer in form of blanket material on top of formation has become a necessity, and adopted in principle over last 15 years.

Earlier, provisions regarding earthwork and blanketing in New Lines/Doubling/ Gauge Conversion works were covered in details in 'Guidelines For Earthwork in Railway Projects', NO. GE:G-1, July 2003 which were mainly applicable upto 22.5 T. However, the provisions contained therein do not specifically address requirements for heavy axle loads.

This *Guidelines* incorporates the recommendations of draft 'Specifications of Formations for Heavy Axle Loads, May 2008 after incorporating suitable suggestions and includes other features such as World Railways' practices for blanketing, formation design methods, ground improvement techniques, quality assurance tests viz. CBR values of subgrade soil, Elastic modulus of compacted layer (EV2) etc.

## 2.0 DEFINITIONS

Commonly used terms in context of the subject and this document, with their specific meanings are mentioned as under:

- 2.1 Formation:** In a general way, collectively refers to the layers comprising blanket, sub-grade / top layer of formation, and embankment fill.
- 2.2 Formation Top:** Boundary( interface) between ballast and top of blanket or subgrade (where blanket layer is not provided).
- 2.3 Track Foundation:** Constitutes ballast, sub-ballast, blanket and subgrade, which is placed / exist below track structure to transmit load to subsoil.
- 2.4 Cess:** Portion at top of formation level, extends from toe of ballast to edge of formation.
- 2.5 Ballast:** Crushed stones with desired specifications placed directly below the sleepers.
- 2.3 Sub-ballast:** Sub-ballast is a layer of coarse-grained material provided between blanket/subgrade and ballast and confined to width of ballast section only. However, sub-ballast is not in vogue on Indian Railways. Therefore, its provision has not been considered in these Guidelines.
- 2.4 Blanket:** Blanket is a layer of specified coarse, granular material of designed thickness provided over full width of formation between subgrade and ballast.
- 2.5 Prepared Subgrade :** The upper part of the subgrade is formed into a prepared subgrade layer, which normally has a crossfall.

**2.6 Sub-grade:** It is the upper part of embankment/cutting provided above subsoil by borrowed soil of suitable quality upto bottom of blanket/ballast. For embankment, subgrade may be of imported soil whereas in cuttings it is the naturally occurring soil of sufficient strength.

**2.6.1 Cohesive Subgrade:** Subgrade constructed with soils having cohesive behaviour i.e., shear strength is predominantly derived from cohesion of the soil is termed as cohesive subgrade. Normally, soils having particles finer than 75 micron exceeding 12% exhibit cohesive behaviour. As per IS classification, all fine-grained soils and GM, GM-GC, GC, SM, SM-SC & SC types of soils exhibit cohesive behaviour.

**Note:** Soil classification in these Guidelines is as per IS: 1498-1970.

**2.6.2 Cohesion-less Subgrade:** Subgrade constructed with cohesion-less, coarse-grained soils i.e., shear strength is predominantly derived from internal friction of the soil are termed as cohesion-less subgrade. Normally, soils having particles finer than 75 micron less than 5% exhibit cohesion-less behaviour. As per IS Classification, GW, GP, SW & SP types of soils fall in this category.

**2.6.3** Other types of soils, which have soil particles finer than 75 micron between 5 to 12%, need detail study for ascertaining their behaviour.

**2.7 Dispersive Soil:** Dispersive clayey soils are those, which normally deflocculate when exposed to water of low salt content. Generally, dispersive clayey soils are highly erosive and have high shrink and swell potential. These soils can be identified by Crumb, Double Hydrometer, Pin Hole and Chemical Tests.

**2.8 Sub-soil:** Soil of natural ground below subgrade and embankment fill.

**2.11 Unstable Formation:** It is yielding formation with continued settlement including slope failure, which require excessive maintenance efforts.

**2.12 Shear Strength:** of soil is its ability to resist shearing at a shearing surface ( plane) under direct stress ( vertical pressure)

**2.13 Soil Pressure Units, equivalence:** 1 Pascal (Pa) = 1 ( N/m<sup>2</sup>)

$$100 \text{ kPa} = 10 \text{ t/m}^2 = 1 \text{ Kg/cm}^2 = 1/10 \text{ N/mm}^2 = 1/10 \text{ MPa}$$

### 3.0 FORMATION COMPONENTS

Formation comprises of Granular layer (sub-ballast and or Blanket) over prepared subgrade and embankment fill. General profile of formation shown below:

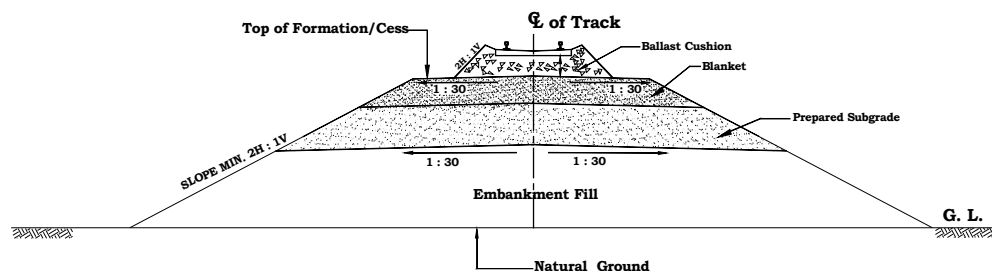

**Fig. 1: Typical Cross-section representing Formation Components**



#### **4.0 SOIL EXPLORATION AND SURVEY**

- 4.1 Objectives of constructing a stable formation can only be achieved if soil exploration, as envisaged in Engineering Code Paras E-409, 425 and 528, is undertaken in right earnest and precautions are taken to design bank & cutting against likely causes which could render it troublesome during service.
- 4.2 Adequate provision for soil surveys & explorations at different stages, as per requirements of the terrain, should be made in the project estimates to cover the cost for this activity.

#### **4.3 Objectives of Soil Exploration:**

Main objectives of soil survey and exploration work are:

- a) to determine soil type with a view to identify their suitability for earthwork in formation and to design the foundation for other structures.
- b) to avoid known troublesome spots, unstable hill sides, swampy areas, soft rock areas, peat lands, etc.
- c) to determine method of handling and compaction of subgrade.
- d) to identify suitable alignment for embankment and cutting from stability, safety, economy in construction and maintenance considerations.
- e) to identify suitable borrow area for desired quality and quantity of subgrade and blanket material.
- f) to determine depth of various strata of soil and bed rock level.
- g) to determine ground water table position and its seasonal variation and general hydrology of the area such as flood plains, river streams, etc.
- h) to determine behaviour of existing track or road structure nature and causes of geo-technical problems in them, if any.

#### **4.4 Soil survey and exploration for construction projects**

Shall be carried out in following three stages:

##### **4.4.1 Soil Investigation during Reconnaissance Survey**

- a) The main objective of soil survey during *Reconnaissance* is to collect maximum surface and sub-surface information without drilling exploratory boring/ test pits to avoid obviously weak locations such as unstable hill sides, talus formation, swampy areas, peat grounds, very soft rocks or highly weathered rocks, etc.
- b) At Reconnaissance stage, available data from geological and topological maps and other soil surveys done in past, existing soil profiles in nearby cuts, quarries are scrutinized. Water table is recorded from local observation and inquiry. The involved soils are classified by visual examination and if necessary, few field/ laboratory tests are conducted for this purpose.
- c) Survey reports available from other Departments/ Agencies such as Geological Survey of India, Ministry of Road Transport and Highways, Central Board of Irrigation and Power(CBIP), CPWD, State Irrigation Deptts., PWDs, etc. can be acquired to obtain information on the accessibility, geology and soils, subsurface information, etc.
- d) Areas of prospective borrow soil and blanket material should also be surveyed to give idea of quality and quantity of materials to be used for construction of Railway embankment.

- e) Above collection of data should be incorporated in the Feasibility Report required to be submitted as per Para E-576 and E-555 in Chapter of Project Engineering under heading of formation (para 528 of Engineering Code).
- f) The data and information collected during survey should be presented in suitable format such as graphs, bar chart or in tabular or statement form.

#### **4.4.2 Soil Investigation during Preliminary Survey**

- a) Primary objective of preliminary exploration is to obtain sufficient subsurface data to permit selection of the type, location and principal dimensions of all major structure and estimation of earthwork and design of formation. The scope of preliminary survey is restricted to determination of depths, thickness and composition of each soil stratum, location of rock and ground water and also to obtain appropriate information regarding strength and compressibility characteristics of various soil strata.
- b) As stated in Para E-409 of Engineering Code, the field work in Preliminary Survey includes a compass traverse along one or more routes with transverse and longitudinal levels to prepare an L-section of routes proposed. This fieldwork shall also cover a soil survey by sampling at suitable intervals in order to obtain a fair idea of the soil classification and characteristics of soils on proposed routes. Testing of disturbed soil samples is usually adequate, however core drilling will be necessary in rocks. This will help in determining thickness of blanket layer on different sections and total quantity of blanket material to be required.
- c) Exploratory boring with hand/ auger samplers and soil sampling should be undertaken along the alignment and soil samples also should be collected from borrow pit area, at an interval of 500 meter or at closer interval, wherever change of soil strata occurs. The boring should be done upto 1.5 to 2.0 m depth below existing ground level. In case of high embankment and problematic substrata, the boring should be taken down to a depth equal to twice the height of embankment. Samples should be collected from each stratum found in each boring.
- d) Bore logs are prepared based on laboratory test results of disturbed samples obtained by auguring or split spoon sampler. Particle size distribution, soil classification and index properties of the soils are determined from laboratory tests.
- e) In case of soft clays and sensitive clays, in-situ vane shear tests should be conducted to determine its shear strength and depth of underlying compressible clay layer. Undisturbed tube samples should also be collected to know actual moisture content, natural dry density and shear and consolidation parameters of the soil.
- f) Geo-physical investigations for bedrock profile, sub-surface strata and soil properties are required to be carried out for foundation of major structures such as bridges. Methods such as Seismic Refraction Method (IS:1892-1979), Standard Penetration Test (IS:2131- 1981), Dynamic Cone Penetration Test (IS:4968-1974) etc, will be required to be carried out to ascertain constituents of substrata and their properties and design foundation of such structures. In alluvial strata, deep auger boring upto 6m may be deployed for subsurface exploration and sampling.
- g) The data and information collected during survey should be presented in suitable format such as graphs, bar chart or in tabular or statement form.

#### 4.4.3 Soil Investigation during Final Location Survey

- a) During Final Location survey, detailed investigations are done at locations where important structures viz. high bank, deep cuttings, major bridges etc. are to be located and where weak sub-soil, swampy ground, marshy land exist. Undisturbed soil samples with the help of deep auger sampler or Split spoon samplers are collected for conducting detailed tests viz. shear strength tests & consolidation test to design safe and economical structure and predict settlements. However, if some tests during preliminary survey are deficient, the same should also be covered.
- b) Assistance may be taken from Geologist, in case of rocky strata, known unstable hill slopes, earthquake prone area and geological fault.
- c) Detailed subsoil exploration is necessary to check stability of structures against failure and to predict anticipated settlement. Bores are made along alignment normally at 200 m to 300m apart in case of uniform type of soil and closely spaced in critical zones. Soil samples within the boreholes are obtained at every change of stratum and interval not exceeding 1.5 m. In case of sandy and gravelly soils, Standard Penetration Test may be adequate, as taking out samples in these types of strata is difficult.
- d) Besides classification tests, soil samples should be tested for shear strength and consolidation properties. In case of very soft clays, vane shear test should be conducted for each boring site. Free swell index test should also be carried out in case of expansive soil and organic contents of soil should be determined if soil is suspected to be having large organic contents.
- e) Sources of blanket material of specified quality and its availability around project site needs to be located to assess its realistic costs for inclusion in project estimates. The source identification should cover various logistics involved in its utilization.
- f) The data and information collected during survey should be presented in suitable format such as graphs, bar chart or in tabular or statement form.

#### 5.0 ASPECTS OF DESIGNING SUBSOIL, EMBANKMENT AND TRACK SUB-GRADE

Formation has to be provided with layers well designed to be safe against shear failure, and accumulated/ plastic deformations under repetitive axle loads.

The Blanket layer and the subgrade layer provide support to the track structure and bear additional stresses due to static and dynamic effects of moving wheel loads. Load is transmitted through the sub-grade and embankment fill layers to subsoil/ ground level.

#### 5.1 Subsoil Deformation:

Adequacy of subsoil as regards shear strength and settlement also require to be examined. Reasons for subsoil deformation loaded by embankment are as enumerated, deformation may be divided in three parts:

- (i) subsoil deformation due to embankment fill loads and relief,
- (ii) settlement of the embankment fill due to deadweight, and
- (iii) deformation ( plastic) due to dynamic influence of traffic loads

Schematic representation of these parts is reflected in figure below.

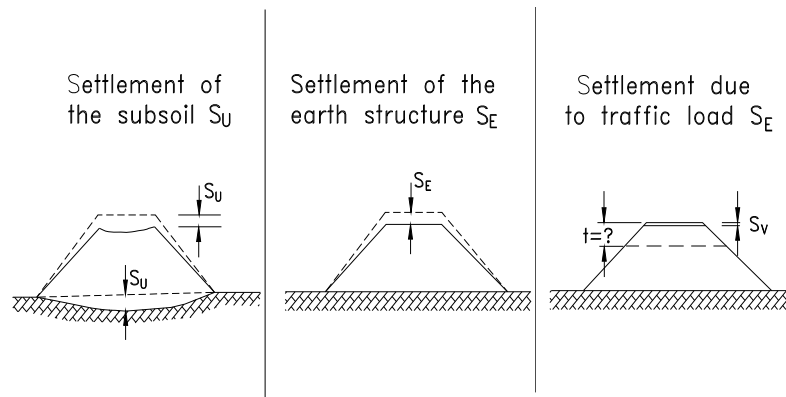

**Fig. 2 : Deformation of the subsoil and embankment fill**

The settlement behaviour of the subsoil loaded by formation/ embankment is influenced by strength and stage of consolidation of the underlying layers. The three phases of deformation/ settlement are:

1. immediate settlement ( gravel and sand)
2. primary settlement (consolidation)
3. secondary settlement ( creep)

Phase-1 settlement is pertinent in case of non-cohesive soils;

phase-2 settlements are decisive for soft cohesive soils without previous loading and may prolong to few years;

phase-3 settlement occurs in soils with high clay content and high content of organic material.

**5.2 Pressure on Formation and sub-soil:** The maximum pressure on formation at bottom of ballast, typical values as good design practice, should not exceed  $0.3\text{MN/m}^2$  or  $3\text{ kg/cm}^2$ , and the pressure on sub-soil should not generally exceed  $0.1\text{MN/m}^2$  or  $1\text{ kg/cm}^2$ , as shown in Fig. 3 below.

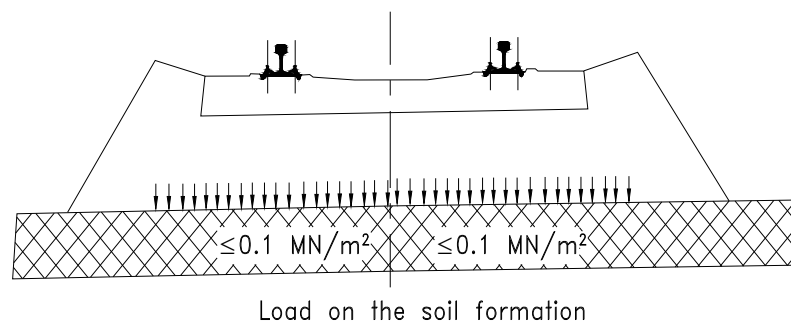

**Fig. 3 : Pressure due to Formation on Ground Soil Layer.**

Indicative load distribution pressure bulb through the layers, due to wheel load, is represented in Fig. 4 below.

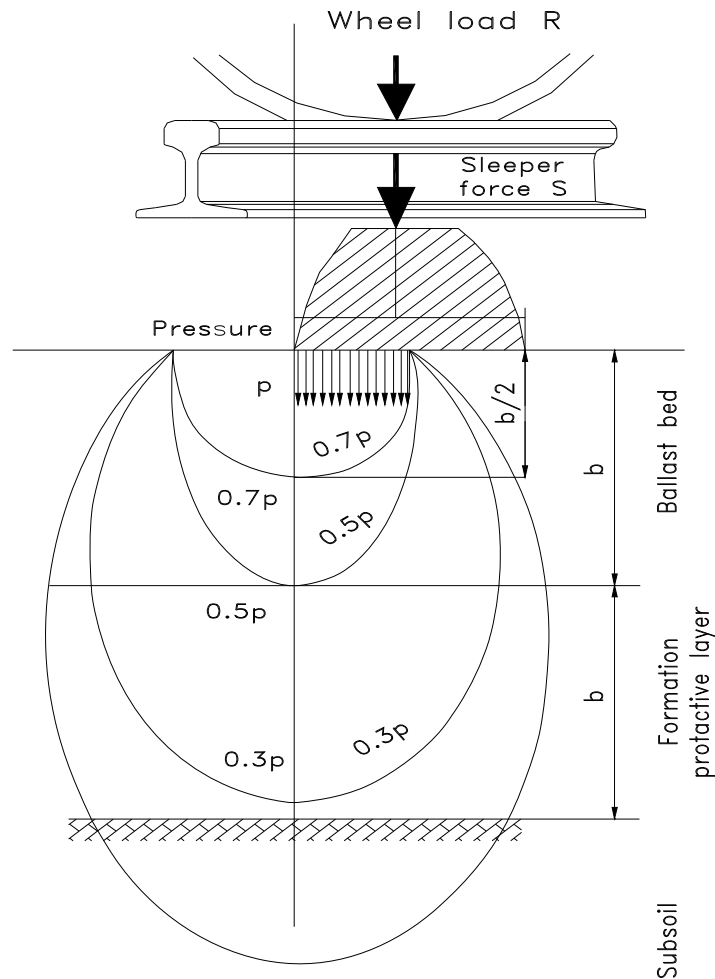

Distribution of force of the wheel load to the subsoil

**Fig. 4 : Wheel Load and Pressure Distribution through Formation.**

#### 5.4 Formation Stresses using Finite Element Analysis

Formation stresses have been also determined by Finite Element Modeling of Ballast and Formation. RDSO has carried out FEM analysis of formation with the help of IIT Delhi. Stresses & deformations have been determined at different level e.g. bottom of sleeper, ballast, blanket, prepared subgrade and soil level for 32.5 T axle load for the three alternatives layer systems. The stresses at soil level are comparable in all the three models. Details of the FEM analysis have been given in Annexure – 3.

#### 5.5 Deficient Shear Strength of Sub-Grade and/or Sub-Soil causes:

- (a) Bearing capacity failure of sub-grade, resulting into cess and crib heave. Deep ballast pockets are formed as a result of such failures. Inadequate cess width is also responsible for initiation and enhancement of bearing capacity failure of subgrade.

- (b) Interpenetration failure or mud pumping failure, resulting into vitiation of clean ballast cushion, and
- (c) Slope failure, if factor of safety against slope stability is not adequate.

Hence, subgrade/subsoil shall be designed and checked to ensure not to allow any shear failure.

## 5.6 Large Deformation without Shear Strength Failures

Large Deformation without Shear Strength Failures of soil can be due to:

- a) Poor compaction during construction and consolidation (primary and secondary) of subgrade and/or sub-soil; and
- b) Settlement and heave due to shrinking and swelling characteristics of subgrade and/or sub-soil. The swelling and shrinkage characteristics of sub-soil shall be significant in cases where bank height is less than 1m or it is in cutting.

These aspects should be taken into account at the time of construction to avoid large settlement causing maintenance problems and leading to formation failure.

## 5.7 Geometrical requirements for the soil formation

Should generally meet following requirements:

- i) cross fall slope to be atleast 1:30 or 3% with tolerance of 0.5%
- ii) the finished top levels should be within + - 3cm
- iii) finished soil surface to be in level in longitudinal direction(  $\leq 2\text{cm}$  on a longitudinal base of 4m), must not show hollow pits, road vehicle traffic ruts
- iv) side slopes to extend in horizontal plane, minimum 10 cm beyond the theoretical finished lines, and later cut and dressed to the specified dimensions.

### **Top Width of Formation:**

- (a) It should be adequate enough to accommodate track laid with concrete sleepers with standard ballast section depth (minimum 35 cm) and have minimum 900mm cess width on either side. It should be regulated in accordance with extant instructions of Railway Board, revisions of IRPWM. Presently, recommended Top Formation Width as per Indian Railway Permanent Way Manual (IRPWM) is 6.85 m for Single line BG Track & 12.15 for double line BG track. However, recommended formation top width for Heavy Axle Load Track is 8.5 m for single line and 8.5 m plus distance between track centers for double line section, and for DFC shall be minimum 13.5 m.
- (b) **Additional Width** of formation will have to be provided to cater for increase in extra ballast on outside of curves and extra clearance required on double line on account of super-elevation etc.

## 5.8 Drainage of Formation-

Water contained in the formation layers cause detrimental conditions in the track. The aim is therefore to contain/ reduce water content in the formation layers by following measures:

- i) removal of vegetation growth on surface

- ii) cleaning of ballast bed and establishing cross fall slope at top of formation/ blanker and sub-grade layers.
- iii) provision of longitudinal drains and drainage outfall, facilities
- iv) arrangement of lateral side drainage facilities.

The top of formation should have cross slope of 1 in 30 from centre of track towards both sides for single line and from one end towards cess /drain side (single slope) in multiple lines. Alternatively, separate cross slope for individual tracks can be also provided with suitable longitudinal drain provided between the tracks at toe of the cross slopes, with suitable cross drain system.

Open Drainage System, typical as shown in Fig. 5 below, facilitates collection of rain water from embankment, cuttings and side of cuttings and lead it away. Similar arrangement can be also provided longitudinally at the lowest point between cross slopes of (separate) formation of two track corridors.

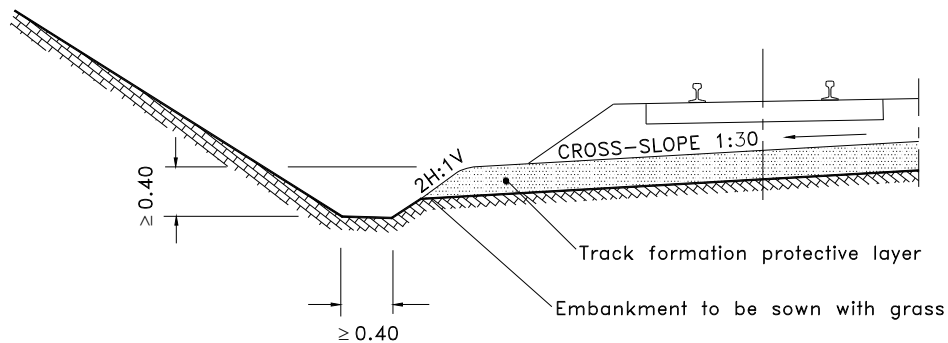

**Fig. 5 : Open Longitudinal Drain at Toe of Formation.**

Sub-soil Drain System (typical as shown below in Fig. 6) are installed where the ground water level has to be lowered (depth < 1.5 m below the rail top), where the soil surrounding the track formation has to be drained or where percolating and layer water has to be drained away.

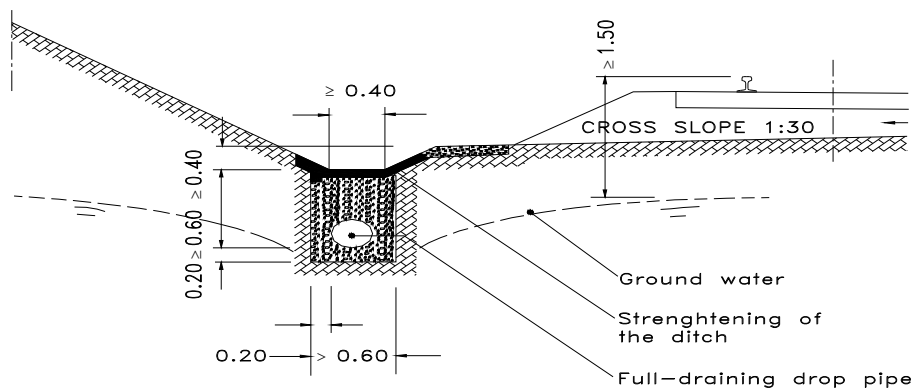

**Fig. 6 : Sub-soil Longitudinal Drainage System.**

- 5.9 The design should provide for a suitable and cost-effective **erosion control** system considering soil matrix, topography and hydrological conditions.

- 5.10 It will be necessary to keep borrow **pits** sufficiently away from the toe of the embankments to prevent base failures due to lateral escapement of the soil. The distance of borrow pit from the bank will have to be decided in each case on its merits. Existing borrow pits, close to toe of bank may be filled or its depth should be taken into account in analysing slope stability of the bank.
- 5.11 In the case of embankments / cuttings in **highly cohesive clayey soils**, special treatment may be necessary to ensure a stable formation. Such measures will have to be determined after thorough investigation and study of the soil properties.
- 5.12 Special investigation will also be necessary in regard to high fill construction on swampy ground or marshy lands and deep cuttings.
- 5.13 In case of all new construction, **minimum height of embankment** should not be less than **one meter** to ensure proper drainage, effective stress dispersal, and uniform riding qualities.
- 5.14 Soils prone to liquefaction falling in gradation zone as per sketch-D of 'Guidelines For Earthwork in Railway Projects', NO. GE:G-1, July 2003 and having coefficient of uniformity,  $C_u < 2$  should not preferably be used in Earthquake prone areas.
- 5.15 Ideal Soil and Poor Soils

Ideal soil has following properties:

- High bearing capacity(BC) in reference to static loads, minor settlement
- High BC in reference to dynamic loads, due to unequal grain size, high structural resistance, and good consolidation
- Elasticity
- Stable as regards erosion
- High water permeability
- Filter criteria w.r.t ballast layer above and sub-soil below
- Cost effectiveness in supply and construction

Natural soils are rarely ideal soils.

Poor Soils:

- Non-cohesive and loose
- Cohesive, soft to semi-solid mixed soils with various contents of sand, silt, clay and water
- Or contain solid rocks of irregular size, solid rocks with cohesive weathering elements.

- 5.16 Bearing Capacity, Subgrade Modulus, Coefficient of Ballast: Typical Issues-

**Bearing capacity**, along with the estimated settlement, is the foremost aspect to be considered for the intended axle loads and the resulting pressure at various levels of the formation layers.

When the bearing capacity is insufficient, application of repeated axle loads shall result in plastic settlement of the embankment and sub-soil in due course of time, resulting in track settlement and degradation.

**Subgrade Modulus-** is a measure of stiffness (of bedding layers), parameter linked to bearing capacity of soil as well, and takes in account deformation



condition. Commonly referred terms and determined in plate load bearing tests (by different organizations) are:

- $E_1$  ... modulus of elasticity at first loading
- $E_2$  ... modulus of elasticity at second loading
- $E_v$  ... modulus of deformation
- $E_{v2}$  ... modulus of elasticity (also deformation) at the second step loading during the plate load test
- $E_{dyn}$  ... modulus under dynamic load; approx. 1.2 to 2.5 times the  $E_2$  modulus; for cohesive soil is of the order 45 N/mm<sup>2</sup>, for non-cohesive – 60 N/mm<sup>2</sup>.
- $E_r$  ... Resilient Modulus of soil layer(subgrade/formation/subsoil layers)

Permissible Contact Pressure and Modulus of Elasticity:

Permissible compressive stress on the formation can be typically estimated using the empirical formula according to Heukelom and Klomp:

$$\sigma_{zperm} = \frac{0.0006 E_{v2}}{1 + 0.7 \log n}$$

Where,  $\sigma_{zperm}$  is permissible compressive stress on the formation,  $E_{v2}$  : Modulus of Elasticity;  $n$ = number of load cycles.

Coefficient of Ballast:

Coefficient of Ballast indicates the track substructure response in terms of surface pressure between sleeper and ballast, and the vertical settlement under load. Quantitatively,  $C = 1 \text{ N/cm}^3$ , is the value of N/cm<sup>2</sup> surface pressure when the sleeper subsides by 1 cm.

Typical values of C, for subsoils with different bearing capacities:

Subsoil	Coefficient of Ballast C ( N/cm <sup>3</sup> )	
	Ballast Bed	Gravel Bed
Very poor subsoil ( marshy ground, fine grained sand)	20	20
Poor subsoil (cohesive, soft to stiff soil) loam, clay	50	50
Good subsoil ( coarse sand, gravel)	100	80-100
Very Good subsoil (gravel, rock)	150-200	100-150

**Table 1 : Typical Values of Soil Types**

Soil Type	$E_{v2}$ ( N/mm <sup>2</sup> )	CBR %	C (N/cm <sup>3</sup> )	$\sigma_{zperm}$ (N/cm <sup>2</sup> )
Soft clay	15	3	28	2.5-3.5
Semi-solid clay	25	5	42	3.5-5.0
Uniform sand	50	10	55	4.5-6.0
Good subsoil	100		69	6.0-7.5

**C**- Coefficient of Ballast: describes the stiffness of ballasted track. In case of road construction is measured by the plate load bearing tests according to:

$C = p / \gamma$  (  $N/cm^3$ ):  $p$ - surface pressure under the loaded plate;  $\gamma$ - settlement of the loaded plate.

Is related to modulus of deformation as

$$C = 2. E_v / ( 3.14. r. (1-v^2) )$$

## 6 FUNCTIONS OF BLANKET LAYER

**6.1** Blanket/ sub-ballast is a layer of coarse grained material between ballast and sub-grade, spread over entire width. On some other railway systems of the world, this layer is also called as sub-ballast. The important roles are:

- i) Improve the bearing capacity by modifying the stiffness and achieving a better distribution of transmitted loads on the sub-grade soil, thus preventing ballast penetration into the subgrade.
- ii) Reduction of induced stresses on the top of sub-grade to a tolerable level.
- iii) To prevent mud pumping and fouling of ballast by upward migration of fine particles from the sub-grade.
- iv) To prevent damage of sub-grade by ballast.
- v) Shedding surface water from the ballast and drain away from the sub-grade.
- vi) Protection of sub-grade against erosion and climatic variations.

### 6.2 Functions :

A blanket/sub-ballast layer fulfils following important functions :

#### 6.2.1 Primary Function :

**Stress Reduction Function** - It reduces the traffic induced stresses on top of sub-grade to a tolerable limit. This function must be fulfilled to avoid track foundation failures.

#### 6.2.2 Secondary Function :

- i) **Separation Function** : It prevents penetration of ballast into sub-grade and also prevents upward migration of fine particles from sub-grade into ballast.
- ii) **Drainage Function** : It should intercept water coming from ballast away from sub-grade and at the same time, permit drainage of water that is flowing upward from the sub-grade.
- iii) **Prevention of Mud Pumping** : It prevents mud pumping by checking attrition of sub-grade particles by ballast.

The quality of blanket material should be such that it is able to carry out the above functions satisfactorily. Various requirements to achieve above objectives are discussed in following paragraphs.

### 6.3 Requirements To Achieve Functions -

One of the most important functions of provision of ballast layer under sleeper is to disperse stresses. Below ballast, layer of sub-ballast/blanket layer of adequate thickness is required to be provided to reduce the induced stresses to an acceptable level at the top of sub-grade to avoid shear stress failure.

For achieving this requirement, blanket material serves as a 'structural' layer/material, which should have adequate strength under dynamic loads and vibrations, high resilient modulus, reasonable plastic strain accumulation characteristics under repeated wheel loads etc. Therefore, the material must be permeable enough to avoid any significant positive pore pressure build-up under repeated load. It must consist of durable particle and should not be sensitive to moisture content. It should also resist break-down and abrasion from the cyclic stresses produced by the train loading.

The demands are fulfilled, if specifications of blanket material fulfil following criteria :

- i) The material is coarse grained, hard and well graded.
- ii) Maximum percentage of fines (particle size less than 75 microns) present in blanket material is limited upto 10% to 12%. Allowing more fines in blanket material will lead to plasticity behaviour of blanket material. Also, a minimum percentage of fines are required to give binding property to the blanket material so that erosion of blanket material does not take place due to high intensity rainfall.
- iii) Material does not liquefy under vibrations caused by train movement and, therefore, is well graded.

## **7 HISTORICAL DEVELOPMENTS ON BLANKET LAYER**

- 7.1 Provision of blanket layer on Indian Railways was stipulated in August-1978 for the first time in the 'Guidelines for Earthwork in Embankments & Cuttings of New Construction, Doubling & Conversion Projects', where it was mentioned that "the depth of blanket should normally be about 30cm in ordinary clayey soil. However, if formation soil is weak, a thicker layer upto 60cm may be necessary depending on the shear properties of the formation soil."
- 7.2 In subsequent reviews, "Guidelines for Earthwork in Railway Projects" was issued in May 1987, where the mention was - "in spite of the present state of knowledge about the soil behavior under repetitive loading, it is not possible to account for the drop of strength under a particular traffic density and wheel loads. In the absence of a sure method of working out thickness of blanket, which would take into account all the factors and keeping the future growth of traffic densities and axle loads as well as the experience with already existing trouble-some formations, one meter thick blanket layer of approved quality should be laid in case of all new constructions".
- 7.3 This subject-matter was further reviewed and as advised by Railway Board vide their letter no. 90/CEII/SF/9, dated 12.4.1991, Para-4.4 was revised and subsequently included in the "Guidelines for Earthwork-1987 as under :

### "Blanket and Sub-ballast :

Blanket : Blanket may be required over the formation where the soil is of poor quality, rainfall is heavy and traffic density is high, as the absence of blanket in such cases can lead to problems in service, such as swelling or heaving of formation. Whether the blanket should be provided in a particular length and if so, its thickness (which should not be less than 30cm) should be decided by the Chief Engineer (Const.), in-charge of the project, duly taking into account the type of soil, rainfall and density of traffic and other factors relevant to the site conditions.

Sub-ballast : In order to reduce the effect of loads transmitted to formation through ballast and to guard against the possibility of ballast penetration into the formation, it may be desirable to provide a sub-ballast of 15cm depth below

the ballast layer. The sub-ballast may comprise of locally available coarse material so as to serve as an effective medium between the formation earth and ballast stone. The need to provide this sub-ballast may be decided by Chief Engineer (Const.) in-charge of the project”.

- 7.4 This above para was corrected vide Correction Slip no. 2 to the above mentioned Guidelines and instructions regarding thickness of blanket were again modified in terms of Railway Board’s letter no. 94/CE-II/MB/2, dated 10.12.98. Perusal of these developments since 1978 to 1991 indicates that :
- (i) Based on experience, necessity was felt for provision of blanket and/or sub-ballast.
  - (ii) Assessment of thickness of blanket material was left on individual judgment, leaving scope for wide variation.
- 7.5 Literature survey was carried out to know the practices being followed in World Railways. Accordingly, “State-of-the-Art-Report on Sub-grade Stress and Design of Track Structure (C-271) June-1993” was published by RDSO. In this report, it was suggested that -
- (i) For sub grades consisting of clayey soils, total depth of ballast & blanket can be worked out using Design Chart (taken from ORE D-7I, RP12) for different axle loads and threshold strength of soil. Threshold stress of soil can be assumed as 45% of UCC strength and
  - (ii) For sub-grades consisting of other than clayey soils, depth of construction will be designed based on Young’s Modulus of Elasticity, i.e. ‘E-values’ of sub-grade soils, as done on European Railways.
  - (iii) It was also concluded that in case of cohesive sub-grades of important lines carrying bulk of the traffic both passenger and goods, there is need of blanket of coarse grained material of about 100 cm thickness to keep the maintenance efforts within reasonable limits.
- 7.6 Further, in the year 2000, Railway Board nominated a committee of four SAG officers who had earlier served Geo-technical Engineering Directorate of RDSO to make recommendation for blanketing on Railway formation. In August 2001, the committee recommended provision of blanket thickness based on various soil types which has subsequently been adopted in RDSO’s revised ‘Guidelines For Earthwork in Railway Projects : July 2003’.

## **8.0 EXISTING PROVISIONS OF BLANKET AND FORMATION ON INDIAN RAILWAYS (Guidelines for Earthwork in Railway Project No. GE:G-1, July 2003)**

### **8.1 Unsuitable Soils for Construction of formation layers:**

Soils to be normally avoided are :

- a) Organic clays, organic silts, peat, chalks, dispersive soils, poorly graded gravel and sand with uniformity coefficient (Cu) less than 2,
- b) Clays and silts of high plasticity (CH & MH) in top 3m of embankment.

### **8.2 Depth of Blanket Layer :**

Depth of blanket to be provided for axle loads upto 22.5t for different types of sub-grade soils (minimum top one metre thickness) has been given as under :

(In case more than one type of soil exists in top one metre, soil requiring higher thickness of blanket will govern)

a) Following soils shall not need any blanket :

- Rocky beds except those, which are very susceptible to weathering, e.g. rocks consisting of shales and other soft rocks, which become muddy after coming into contact with water.
- Well graded Gravel (GW)
- Well graded Sand (SW)
- Soils conforming to specifications of blanket material.

Note : Soils having grain size curve lying on the right side of the enveloping curves for blanket material like cobbles and boulders may/may not need blanket. In such cases, need of blanket and its design should be done in consultation with RDSO.

b) Following soils shall need minimum 45cm thick Blanket :

- Poorly graded Gravel (GP) having Uniformity Coefficient more than 2.
- Poorly grade Sand (SP) having Uniformity Coefficient more than 2.
- Silty Gravel (GM)
- Silty Gravel – Clayey Gravel (GM – GC).

c) Following soils shall need minimum 60cm thick Blanket :

- Clayey Gravel (GC)
- Silty Sand (SM)
- Clayey Sand (SC)
- Clayey Silty sand (SM-SC)

Note : The thickness of blanket on above type of soils shall be increased to 1 metre, if the plasticity index exceeds 7.

d) Following types of soils shall need minimum 1 metre thick Blanket :

- Silt with low plasticity (ML)
- Silty clay of low plasticity (ML-CL)
- Clay of low plasticity (CL)
- Silt of medium plasticity (MI)
- Clay of medium plasticity (CI)
- Rocks which are very susceptible to weathering

Soils having fines passing 75 micron sieve between 5 & 12%, i.e. for soils with dual symbol, e.g. GP-GC, SW-SM, etc., thickness of blanket should be provided as per soil of second symbol (of dual symbol). For example, if the soil of the sub-grade over which the blanket is to be provided is classified as GP-GC, blanket depth for GC type of soil, i.e. 60 cm is to be provided.

Use of geo-synthetics can be considered at places where it is economical to use in combination with blanket as it reduces the requirement of thickness of blanket. It may be particularly useful in cases of rehabilitation of existing unstable formation and in new construction where availability of blanket material is scarce. Use and selection of geo-synthetics should be done in consultation with RDSO.

For heavier axle load traffic above 22.5t and upto 25t & above 25t upto 30t, additional blanket thickness of 30cm & 45cm respectively, over and above as given above, of superior quality material, shown as upper blanket layer in Sketch "B" of RDSO document 'GE:G-1, July 2003, should be provided.

### 8.3 Specifications of Blanket Material

Blanket material should generally conform to following specifications :

- a) It should be coarse, granular and well graded.
- b) Skip graded material is not permitted.
- c) Non-plastic fines (particles of size less than 75 micron) are limited maximum to 12%, whereas plastic fines are limited maximum to 5%.
- d) The blanket material should have particle size distribution curve more or less within the enveloping curves shown in Sketch-B of RDSO document 'GE:G-1, July 2003'. The material should be well graded with  $C_u$  and  $C_c$  as under :
  - Uniformity Coefficient  $C_u = D_{60}/D_{10} > 4$  (preferably  $> 7$ )
  - Coefficient of Curvature  $C_c = (D_{30})^2 / D_{60} \times D_{10}$  should be within 1 & 3.
- e) The material for upper blanket layer, required for heavier axle load, shall be well- graded sandy gravel or crushed rock within the enveloping curves for upper blanket layer as shown in Sketch-B of RDSO document 'GE:G-1, July 2003'.

### 9.0 PROVISIONS OF BLANKET IN OTHER RAILWAY SYSTEMS

For comparison purpose, it would be prudent to study the provisions regarding thickness and speciation of blanket material in leading railway systems of the world. Blanket is provided invariably for all types of subgrade in these railway systems. Top layer of 50cm to 1m of formation depending on type of soil used as embankment fill, is treated as structural zone and is provided with controlled quality of well-graded sandy gravel material with or without geo-grid and or textile. Quality of compaction is also sometimes different of this top layer of formation.

Detailed literature survey has been done regarding the provisions of blanket in American Railways, UIC (European Railways) & Australian Railways where it is well known to have good quality of formation used for running of heavy axle loads as well as high-speed train operation. The provisions in these railways have been kept in view to finalise specifications of blanket layer, recommended in the present document. Further details regarding provisions of blanket layer in these world railway systems are given in Appendix-A.

### 10.0 DESIGN METHODS/PRACTICE IN WORLD RAILWAY SYSTEMS

Various design methods of formation, particularly for blanket thickness, are in use in different railway systems. These are based on different properties of soil used in embankment construction which govern the behavior of soil viz. percentage of fines (size less than 75 microns) present in the soil, *CBR* value of soil, undrained shear strength  $C_u$  of soil etc. These methods have been described briefly as under :

#### 10.1 UIC method (*Based upon fines in soil*)

Basis of the design is mainly governed by the percentage of fines present in the subgrade soil. The different soils have been grouped in three soil groups viz. QS1, QS2 & QS3 based mainly on percentage of *fines* in the soil. The blanket thickness for a soil of a particular group has been determined for different axle

load, speed, GMT and other parameters. This method has already been described briefly in para 6.1 which is based on UIC Code 719 R, 1994 and ORE report No. D - 117 RP 28.

### 10.2 British Railway Method (*Based on Threshold Stress of soil*)

This method developed by British Railways in 1970s, deals with selecting the granular layer thickness based on *threshold strength* of the subgrade soil. The objective is to limit the stress on the subgrade soils to less than a *threshold* stress in order to protect against subgrade failure by excessive plastic deformation, more pertinent in case of cohesive soils.

The *threshold* stress is determined from repeated load tests in which the cumulative strain of the soil layer is noted as a function of the number of loading cycles applied. For such (clay) subgrade soils, there exist a value of the stress below which soil will experience terminating deformation but if subjected to the stress value higher than that, the soil show non-terminating deformation ( i:e: the rate of cumulative plastic deformation is extremely rapid) and ultimately fails in shear. Such limiting value of the stress has been termed as *threshold* stress. Such soils subjected to repetitive triaxial tests in laboratory would fail before certain nos. of cycle ( typically 3000) application of test loads causing stress above the *threshold* stress levels.

Design procedure involves determination of stress at top of subgrade due to design axle load including dynamic augment. *Threshold* stress is determined by conducting cyclic triaxial tests on soils. Blanket thickness is determined such that stress at top of subgrade due to moving axle load is less than *threshold* strength of the subgrade. In absence of cyclic triaxial tests, *threshold* strength of subgrade can be approximated as 45% of Unconfined compressive strength of (clayey) subgrade.

Design curves for the subgrade giving the depth of granular layer (ballast & blanket) have been developed for different axle loads and *threshold* strength of soil, and given in ORE Report No. D-71 RP 12.

### 10.3 Association of American Railroads (AAR) Method ( by Li and Selig ) :

The AAR method is based on the Li & Selig (1998) design approach developed for design of sub-grade, and adopted on American Railways System. Li & Selig (1998) based on detailed experimental observations, presented a rational design method and considered two failure criteria:

- (i) Progressive shear failure
- (ii) Excessive plastic deformation

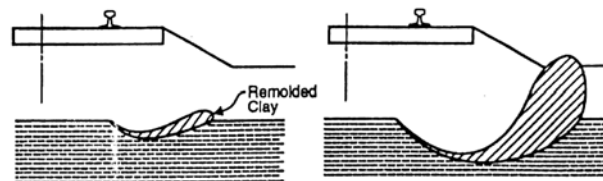

**Fig 7 . Sub-grade progressive shear failure**

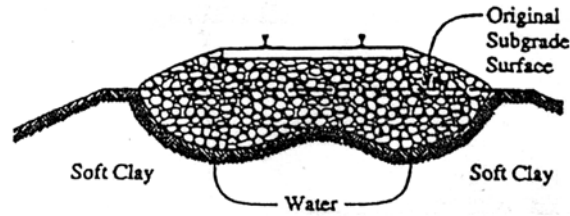

**Fig. 8 : Excessive Sub grade Plastic Deformation (Ballast Pocket)**

**Design Criteria:** The two criteria used to design the granular layer ( ballast + sub-ballast) thickness on top of formation, for preventing subgrade failures, are based on: (i) limiting cumulative plastic strain at the subgrade surface, intended to prevent subgrade progressive shear failure, and (ii) criterion to prevent excessive sub grade plastic deformation.

Both criteria need to be evaluated to determine the one that gives the larger granular layer thickness in each case.

**Design Procedure 1** - This design procedure is used for determining granular layer thickness based on criterion of limiting cumulative plastic strain at the subgrade surface. The design procedure consists of the following 3 steps:

1. Prepare the information required for the design, including:

*Traffic conditions:* Dynamic wheel load must be determined using eq. (i) or based on actual measurements, and the number of load repetitions for the design period must be determined using eq. (ii)

$$(i) \quad (P_{di}) = (1 + 0.0052V/D) P_{si}$$

$$(ii) \quad N_i = T / (8 P_{si})$$

Where,  $P_{di}$  - dynamic wheel load in kN,

$P_{si}$  - static wheel load in kN,

$V$  - speed in kmph

$D$  - Wheel Diameter in meter,

$N_i$  - Number of load repetitions in the design period

$T$  - Total traffic tonnage for the design period

$\epsilon_{pa}$  - allowable cumulative plastic strain at sub grade top

*Allowable strain:* The magnitude of the allowable cumulative plastic strain at the sub grade surface  $\epsilon_{pa}$  must be determined for a certain number of load repetitions (i.e. for the design period)

*Sub grade characteristics:* The sub grade soil type, soil compressive strength  $\sigma_s$  and the soil resilient modulus  $E_s$  must be determined.

*Granular material:* The resilient modulus  $E_s$  for the granular material must be specified.

2. Determine the allowable deviator stress at the sub grade surface. This can be done using the charts in Appendix A of AAR Report No. R-898. This is completely based on the information obtained from step 1, i.e. soil type, the allowable cumulative plastic strain at the sub grade surface for the design period, and the soil compressive strength. However as an alternative to the allowable strain determined from the first step, the allowable deviator stress at the sub grade surface may be selected directly at this step.



3. Select the required granular thickness to prevent the sub grade progressive shear failure as follows:

- Calculate the strain influence factor  $I_e$  by the equation,  $I_e = \sigma_{da} A / P_{di}$   
 Where  $\sigma_{da}$  = allowable deviator stress at the sub grade surface determined from step 2;  $P_{di}$  = design dynamic wheel load determined from step 1; and  $A$  = area factor used to make the strain influence factor dimensionless. The area factor  $A$  is  $0.645 \text{ m}^2$  ( $1000 \text{ in}^2$ ).
- Determine the value of  $H/L$  ( $H$  – Granular Layer Thickness &  $L$  – Length Factor) corresponding to the strain influence factor  $I_e$  using a design chart A2 in Appendix A of AAR Report No. R-898 (Li & Selig October 1996), for the values of granular layer resilient modulus  $E_b$  and the sub grade resilient modulus  $E_s$ .
- Multiply  $H/L$  by the length factor  $L$  to get the required granular layer thickness  $H$ . Length factor is used to make the design charts dimensionless. The  $L$  is equal to  $0.152\text{m}$  ( $6 \text{ in}$ ).

**Design Procedure 2** – This procedure is based on the criterion which limits total plastic deformation of the subgrade layer. The granular thickness design consists of the following 3 steps:

1. In addition to the information required in design procedure 1, design procedure requires knowledge of the thickness of the deformable sub grade layer  $T$ . The allowable cumulative plastic strain at the sub grade surface for design procedure 1 is replaced by the allowable total plastic deformation of the sub grade layer for design procedure 2.
2. Calculate the deformation influence factor  $I_p$  by the following equation (Li and Selig 1998):

$$I_p = \frac{\rho_a / L}{a (P_d / \sigma_s A)^m N^b} \times 100$$

Where:

- $\rho_a$  = allowable total sub grade plastic deformation for the design period
- $N$  = total equivalent number of load repetitions during the design period
- $P_{di}$  = design dynamic wheel load
- $\sigma_s$  = soil compressive strength
- $a, b, m$  = material (soil) parameters
- and  $A, L$  = area and length factors.

3. Select the required granular layer thickness to prevent excessive sub grade plastic deformation as follows:
  - Select the design chart as given in Appendix B that the best corresponds to the existing soil type, sub grade resilient modulus, and granular layer resilient modulus.
  - Calculate  $T/L$  (where  $T$  is thickness of deformable subgrade layer from bottom of granular layer to top of rigid layer) and locate the point in design chart as given in Appendix B corresponding to  $I_p$  and  $T/L$ . Obtain the value of  $H/L$  for that point, and multiply  $H/L$  by the length factor  $L$  to get granular layer thickness  $H$ .

## 11.0 DESIGN OF FORMATION FOR 25, 30 & 32.5 T AXLE LOAD ON THE BASIS OF DIFFERENT METHODS

Calculations of blanket thickness requirement have been done based on above methods for 25T, 30T & 32.5T axle loads. These are as under :

### 11.1 UIC Method (*Based on fines in Soil*)

Recommendations have been made in UIC Code 719 for axle loads in range of 20 to 25 tonne. Since formation design is to be done for 30 T & 32.5 T axle loads, extrapolation has been done for 30 tonne and 32.5 tonne axle loads from UIC provisions. Keeping in view the other relevant factors, Speed, GMT, Sleeper Length suitable for Indian Railways, detail calculations of blanket thickness for various soils, based on UIC practices have been carried out.

Calculated Thickness of blanket material & prepared sub-grade and type of sub-grade alongwith soil types as per IS Classification belonging to various 'Soil Category SQ' have been given in Table-2. Soil Categories SQ1, SQ1 & SQ3 have been modified slightly from UIC practices to suit Indian conditions & BIS Classification system.

**Table 2 - UIC Based Two Layers System of Blanketing On Track Formation**

(Ref : Calculations based on UIC practices in terms of UIC Code 719R-1994)

Soil Quality Category in Sub-grade	Top Soil of Formation (prepared Subgrade)		Recommended Thickness (mm) of Blanket for Axle Loads		
	Quality	Thickness (mm)	25 T	30T	32.5 T
SQ1	SQ2	500	250	450	600
SQ1	SQ3	500	150	350	500
SQ2	SQ2	-	250	450	600
SQ2	SQ3	350	150	350	500
SQ3	SQ3	-	150	350	500

1. Thickness of blanket material has been worked out with the provision of 300mm ballast.
2. Recommended blanket thickness is suitable for GMT  $\geq 25$  & Speed  $< 160$  kmph.
3. Geo-textile should be provided below blanket layer, if prepared subgrade is of SQ2 soil.

Soil Quality Class SQ1, SQ2 & SQ3 has been given in Table 3 below.

**Table 3 - Description of Soil Quality Class**

Soil Quality	Description w.r.t. Fine-Particles (size less than 75 micron)	Soils as per IS Classification Conforming to Referred Soil Quality
SQ1	Soils containing fines $> 50\%$	CL, ML, CL-ML, CI, MI, CH, MH
SQ2	Soils containing fines from 12% to 50%	GM, GC, SM, SC
SQ3	Soils containing fines $< 12\%$	GW, GP, SW, SP, GW-GM, GW-GC, SW-SM, GP-GM, GP-GC, SP-SM, SP-SC

### 11.2 AAR Design (Selig Method) – Based on Cumulative Strain & Plastic Deformation Criteria

Based on AAR method, as described in para 6.3 above, calculations have been done for 25, 30 & 32.5 T for different values of Compressive Strength,  $\sigma_s$  of soils. The results of calculated blanket thickness are given in Table 4 below.

**Table 4 - Calculation of Blanket Thickness (in cm) For different Axle loads & CBR of soil**

CBR (%) (Indicative value)	Subgrade Compressive Strength $\sigma_s$ (kPa)	Axle Load 25 T			Axle Load 30 T			Axle Load 32.5 T		
		From Cumulative Strain Criterion	From Cumulative Deformation Criterion	Maximum of two Criterion	From Cumulative Strain Criterion	From Cumulative Deformation Criterion	Maximum of two Criterion	From Cumulative Strain Criterion	From Cumulative Deformation Criterion	Maximum of two Criterion
2	60	120	120	<b>120</b>	-	-	-	-	-	-
3	90	70	85	<b>85</b>	120	120	<b>120</b>	-	-	-
4	120	30	25	<b>30</b>	55	50	<b>55</b>	75	75	<b>75</b>
5	150	15	Nil	<b>15</b>	25	15	<b>25</b>	35	40	<b>40</b>
6	180	Nil	Nil	<b>Nil</b>	15	Nil	<b>15</b>	20	Nil	<b>20</b>

- Note :
- Value of T (here T is assumed as 2m), the depth of deformable layer is site specific. Hence, actual design may vary from site to site.
  - AAR method is based on the approach that stress on subgrade is less than permissible strength such that plastic cumulative deformation does not take place over the design period.
  - Calculations for granular layer thickness have been done using soil parameter & chart of CH type of soil assuming worst soil conditions.

The design calculations have been done with following assumptions of typical values or empirical relations :

- Soil Compressive Strength, (in kPa) ,  $\sigma_s = 30 \times \text{CBR}$
- Elastic Modulus of ballast,  $E_b$  has been assumed to be 140 MPa.
- Elastic Modulus of Soil,  $E_s = 10 \times \text{CBR}$  (For  $\text{CBR} \leq 5$ ) &  $E_s = 17.6 \times \text{CBR}^{0.64}$  (For  $\text{CBR} > 5$ ) (Ref : Page no 53 of IRC Guidelines for the Earth design of flexible pavements, IRC:37-2001)
- Values of a, b & m for soil & Curves for Soil have used for CH type soil..
- Depth of deformable subgrade, T has been assumed as 2.0 m.
- GMT is 30 and design period is 5 year. ( i.e. Total Design GMT is 150)
- Permissible cumulative plastic strain,  $\epsilon_{pa}$  at the end of design period is 2%.
- Permissible cumulative plastic deformation at the end of design period is 25 mm.
- Ballast Thickness is 30 cm.

## 12. RECOMMENDED SPECIFICATIONS OF BLANKET MATERIAL (Mandatory)

12.1 Specifications of the material for blanket layer over prepared sub-grade should be such that it is well-graded sandy gravel layer of adequate hardness. Particles size gradation curve should be more or less within Enveloping Curves of blanket material as shown in Fig. 9 below & Grading Percentages within the range given in Table-5 below and should also have following criteria satisfied :

- $C_u > 7$  and  $C_c$  between 1 and 3.
- Fines (passing 75 microns) : 3% to 10%.
- Los Angeles Abrasion value < 35%.
- Minimum required Soaked CBR value 25 of the blanket material compacted at 100% of MDD

In exceptional cases on technical and economic considerations, LAA value may be relaxed upto 40% by Pr CE on Open Line & CAO/C in construction projects.

v) Filter Criteria should be satisfied with prepared subgrade/subgrade layer just below blanket layer, as given below :

- Criteria-1: D15 (blanket) < 5 x D85 (sub-grade)
- Criteria-2: D15(blanket) > 4 to5 D15 (sub-grade)
- Criteria-3: D50(blanket) < 25 x D50 (sub-grade)

12.2 Filter Criteria is optional, at present. This can be adopted with the experienced gained of its compliance for different types of soils with blanket.

**Table-5 : Grading Percentage of Blanket Material**

SL	IS Sieve Size	Percent Passing (by weight)
1.	40 mm	100
2.	20 mm	80 - 100
3.	10 mm	63 - 85
4.	4.75 mm	42 - 68
5.	2 mm	27 - 52
6.	600 micron	13 - 35
7.	425 micron	10 - 32
8.	212 micron	6 - 22
9.	75 micron	3 - 10

**Fig. 9 : Enveloping Curves for Blanket Material:**

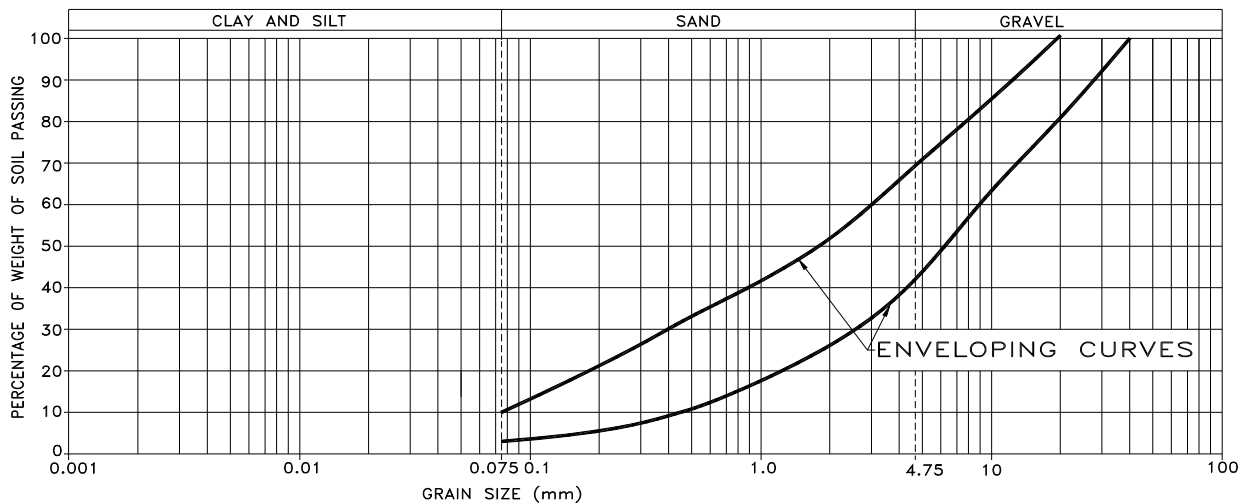

**13.0 QUALIFYING AND QUALITY ASSURANCE TESTS (Mandatory)**

Qualifying tests as part of pre-selection of good earth for track subgrade, embankment fill is required to be carried out.

Also, quality of compaction is required to be done to ensure good quality construction.

**i) Selection of soil:** For selection of soil to be used as embankment fill **CBR test** is required to be conducted on material. CBR test is conducted on ground soil, embankment fill, prepared sub-grade & blanket material to ensure the minimum specified CBR value of these materials to be used in construction.

This test is carried out on soil sample in laboratory as per procedure given in IS:2720 (Part 16)-1987 & in field as per IS:2720 (Part 31)- 1969.

**ii) Quality Assurance Test on Compacted Layer :** Quality Assurance Tests are required to be conducted on part completion stages of formation, prior to clearing for further earthwork, track linking work:

**Heavy Proctor test** is required to be conducted to determine the Maximum Dry Density of soil as per IS: 2720 (part 8). In-situ density is measured in the field by Sand Replacement Method (IS: 2720 – part 28) or Core Cutter Method (IS: 2720 – part 29) to calculate the degree of compaction. this shall be determined in laboratory as per BIS procedure with the specified frequency of earthwork quantity, as envisaged in 'Guidelines of Earthwork in Railway Projects, GE:G-1, July 2003.

**Second Step Plate Load Test (Optional)** is required to be conducted in-situ for measurement of Deformation Modulus  $E_{v2}$  of compacted layers of embankment, blanket, prepared subgrade etc. The test procedure has been detailed in German Code DIN:18134- 2001,'Determining Deformation & Strength Characteristics Of Soil By Plate Loading Test". The minimum value of  $E_{v2}$  should be ensured at different levels as specified.

Brief procedure of these above tests has been given in Annexure-2.

### 13.1 Frequency of Quality Assurance Tests

- a) CBR test for selection of formation materials and other tests required for ensuring conformation of the materials (blanket, subgrade) as per specification e.g. size gradation,  $C_u$ ,  $C_c$ , Los Angeles Tests, OMC/MDD etc. shall be conducted at following frequency :
  - i) Embankment Fill : one set of tests for every 5000 cum
  - ii) Prepared subgrade : one set of tests for every 2000 cum
  - iii) Blanket material : one set of tests for every 500 cum
- b) In-situ Degree of Compaction (or In-situ dry density measurement) test shall be conducted on each compacted layers in random pattern at following frequency for the different layers :
  - i) Embankment Fill : one density measurement at every 500 sqm surface area of each compacted layers
  - ii) Blanket and Prepared Subgrade : one density measurement at every 200 sqm surface area of each compacted layers.
- c) Second step Plate Load Test : This test is in practice in German Railways and recommended by UIC Code 719 to measure the quality of earthwork and blanketing after compaction. For Indian Railways, this test is made optional presently. In the guidelines, this test has been included as a future development for quality assurance test on compacted surface. This should be done for  $E_{v2}$  measurement at top of each formation layers eg. at sub-soil, compacted subgrade, prepared subgrade, blanket etc. at the frequency of one test per km length of section.

### 14.0 GROUND IMPROVEMENT METHODS :

- 14.1 Field tests are required to be conducted on sub-soil strata, such as Plate load test for determination of Elastic Modulus at second loading ( $E_{v2}$ ), Standard Penetration test to determine N-value, and Unconfined Compression Test or Vane Shear Test to determine unconfined compressive strength or undrained

cohesion,  $C_u$ . If values of these test parameters, as specified in following para are not achieved then ground improvement is required.

14.2 For ground soil/ sub-strata layers with low bearing capacities, assessed by following evaluation parameters:

- (i)  $E_{v2}$  value less than 20 MPa, (Optional) or
- (ii) undrained cohesion ( $C_u$ ) < 25 kPa, or
- (iii) N-value (determined from Standard Penetration Test –SPT ) < 5, shall require Ground Improvement.

Strengthening of sub-strata soil layers can be carried out using one or more of the following techniques, like:

- removal and replacement ( R&R) of weak soil,
- stage constructions of the fill, preloading and surcharging,
- Installation sub drainage system,
- In-situ pile, Sand Gravel Compaction pile, Stone Columns
- Vibro-floatation,
- lime pile, Injection/ lime slurry pressure injection/ion exchange,
- Stir & Mixing,
- Sand mat, Geosynthetics etc.

14.3 Brief on Ground Improvement Techniques has been given in Annexure-1. However, details of Some Ground Improvement Techniques are available in Various RDSO reports on RDSO website - [www.rdsogov.in](http://www.rdsogov.in).

## **15.0 DISCUSSIONS ON FORMATION LAYERS SYSTEM :**

From the stress analysis, it is evident that most of stresses for heavy axle load up to 32.5 T load are dissipated upto 1.5 m depth below bottom of ballast, thereafter the stresses are within tolerable limit of stresses including reasonable factor of safety for soils. The major stress region occurs upto depth of 1 to 1.5m below bottom of ballast. This region is to be provided with blanket layer which or in lower layers supplemented / replaced by prepared subgrade particularly in bottom portion. Also, below the blanket layer, the layer of prepared/ good imported soil with minimum prescribed CBR value is essential and has been recommended as prepared subgrade layer upto depth of about 1.5m below top of formation.

Considering the relevant good features of Indian Highway system (Ref; Indian Road Congress Code, IRC:37 on 'Guidelines & Design of Flexible Pavements) and foreign railway practices, strength based design system has been evolved. Minimum CBR value of subgrade/prepared subgrade have been prescribed for selection of soil/material for the subgrade.

From the perusal of practices adopted in other leading railway systems, it is evident that multi-layer formation system – layers with adequate strength and stiffness to be adopted. Layers comprise of blanket layer, prepared subgrade/top layer of formation etc. is preferred in place of single layer blanket system. The specifications and thickness of various formation layers specified are in line with practices of UIC, AAR and other World Railways.

## **16. FORMATION OF REVIEW COMMITTEE & RAILWAY BOARD'S APPROVAL :**

Railway Board, Vide letter no. 2007/CE-1/Geotech/02 dated 06.08.2009, nominated a Special Committee to deliberate upon draft 'Guidelines and Specifications for Formation of Heavy Axle Load', July 2009 with the term of references as cost aspects and material availability and suggestions for new lines/doubling/Gauge Conversion for axle loads in range of 22.5t to 25t. The committee consists of :

1. CAO(C)/WR – Presiding Officer
2. Sr. EDGE/RDSO, Convener Member
3. CAO(C)/NCR – Member
4. CAO(C)/SR – Member
5. Representative from RVNL – Member

The committee deliberated on the draft Guidelines and submitted its recommendations on 12.10.2009.

The committee did not considered necessary three layer system of formation consisting of blanket, crusher run & prepared subgrade based on cost aspects and material availability, as cir in draft '*Specifications of Formation for Heavy Axle Load*', May 2008.

The committee recommended adoption of mechanical production blanket material, if required.

The committee also recommended adoption of formation standards of 25 T for new lines/doubling/GC for axle loads in range of 22.5 to 25 T.

Recommendations were approved by the Railway Board vide letter no. 2007/CE-I/Geotech/02 dated 26.10.2009. As per Railway Board, these guidelines should be put to use only on new works and would not apply to ongoing projects. This may be first tried out for a year and half to get the field appreciation and correction required, if any.

The minutes & recommendations of the committee & Railway Board's approval letter of the Guidelines have been given in Appendix-B.

## **17. SPECIFICATIONS & RECOMMENDATIONS : (Mandatory)**

17.1 The following *Specifications* for two different systems for blanket, subgrade, embankment fill are mandatory provisions to be adopted, as follows:

- i) Conventional blanket layer over formation subgrade
- ii) Blanket layer over prepared subgrade layer (good/imported soil)

Any of the two system may be considered for adoption in the field based on *good* soil availability and material cost economics. These are given in form of following:

- a) Table 6 (Specification and thickness of subgrade layers for Heavier Axle Loads),
- b) Formation cross-sections (Fig. 10 – Formation Profiles and Layers for Heavy Axle Load), and
- c) Bar Diagrams (Fig. 11 – Formation Layer Thickness).

17.2 In order to design & construction of stable formation for heavy axle load, EV2 should be determined in the field as per procedure given in German Code DIN : 18134 at ground. Undrained shear strength,  $C_u$  of ground soil from Unconfined Compression (UCC) test or Vane Shear Test and Penetration Number (N – Value) from Standard Penetration Test should also be determined. If EV2 value is less than 20 MPa or Sub-soil strata having ( $C_u$ ) < 25 KPa (mostly in Marshy area) or N-value < 5 will also require ground improvement.

17.3 If, naturally available materials do not meet the desired specifications, blanket material can be produced by mechanical process from crushing or blending method or combination of these two methods. Details of these two methods are given in Appendix – C. Naturally available sand, quarry dust or crusher run, if available at low cost, can be used as prepared subgrade also.



**Table 6 - Specification and thickness of subgrade layers for Heavier Axle Loads****1. Single Blanket Layer over Embankment Fill- Specification and Layer Thickness**

Layers	Specification	Axle Load 25T	Axle Load 30 T	Axle Load 32.5T
Blanket – Well Graded Sand Gravel Layer	i) $C_u > 7$ and $C_c$ between 1 and 3. ii) Fines (passing 75 microns) :3% to 10% iii) Los Angeles Abrasion value < 40% (iv) Minimum CBR value 25 of the blanket material compacted at 100% of MDD (v) Size gradation within specified range or enveloping curves. (vi) Filter Criteria should be satisfied with subgrade layer, as given below : Criteria-1: $D_{15}(\text{blanket}) < 5 \times D_{85}(\text{sub-grade})$ Criteria-2: $D_{15}(\text{blanket}) > 4 \times D_{15}(\text{sub-grade})$ Criteria-3: $D_{50}(\text{blanket}) < 25 \times D_{50}(\text{sub-grade})$ Minimum $E_{v2}$ – determined from 2 <sup>nd</sup> step Plate Load Test on top of compacted blanket layer (Ref : German Code : DIN 18134 – 2001)	60 cm for SQ3, <u>75 cm for SQ2</u> 100 cm for SQ1 ( SQ1 only with dispensation of PCE/ CAO) SQ2/SQ3 are preferred soil below blanket. Blanket Compacted upto 98 % MDD Min. $E_{v2}$ – 100 MPa	75 cm for SQ3, <u>80 cm for SQ2</u> SQ2/SQ3 are preferred soil below blanket. Blanket Compacted upto 100% MDD For new line construction, Min. $E_{v2}$ – 120 MPa As in-situ Assurance Test	80 cm for SQ3, <u>100 cm for SQ2</u> SQ2/SQ3 are preferred soil below blanket. Blanket Compacted upto 100% MDD For new line construction, Min. $E_{v2}$ – 120 MPa As in-situ Assurance Test
Embankment Fill Top Layer of Thickness (T)	CBR= 7 - 5 (of compacted soil at 98% of MDD) (Organic soils to be avoided) ( SQ1 to be avoided) Minimum $E_{v2}$ = 45 MPa Compaction :	T = 50 cm SQ2/SQ3 soils CBR > = 6 generally, but not < 5 in isolated cases (For SQ1 soil, CBR > = 4 generally, but not < 3 in top 1 m. & for Lower Fill Layers CBR > = 3) Compacted upto 97% of MDD	T = 75 cm SQ2/SQ3 soils CBR > = 6 generally, but not < 5 in isolated cases Compacted upto 98% of MDD	T = 75 cm SQ2/SQ3 soils CBR > = 7 generally, but not < 6 in isolated cases Compacted upto 98% of MDD
Ground Soil/Sub-soil Strata	Minimum Undrained Cohesion of soil, $C_u = 25$ KPa or Minimum $E_{v2} = 20$ MPa Ground Improvement is required, if $C_u < 25$ kPa or $E_{v2} < 20$ MPa	Min. $E_{v2} = 20$ MPa	Min. $E_{v2} = 20$ MPa	Min. $E_{v2} = 20$ MPa

- Note :**
- SQ1 (fines > 50%), SQ2 (fines : 12 to 50 %), SQ3 (fines < 12%)
  - For axle load 25 T and higher, blanket & Embankment fill thickness can be reduced with determination of soil strength parameters CBR & Threshold stress determined based on repeated Triaxial tests.
  - Uniform total thickness of formation layers of 2 m should be provided including blanket, top layer of embankment fill etc.

**2. Two Layer System (Blanket & Prepared Subgrade on Embankment Fill)**

Layers	Specification	Axle Load 25T	Axle Load 30 T	Axle Load 32.5T
Blanket – Well Graded Sand Gravel Layer	i) $C_u > 7$ and $C_c$ between 1 and 3. ii) Fines (passing 75 microns) :3% to 10% iii) Los Angeles Abrasion value < 40% (iv) Minimum CBR value 25 of the blanket material compacted at 100% of MDD (v) Size gradation – within specified range or enveloping curves (vi) Filter Criteria should be satisfied with subgrade layer, as given below : Criteria-1: $D_{15}(\text{blanket}) < 5 \times D_{85}(\text{sub-grade})$ Criteria-2: $D_{15}(\text{blanket}) > 4 \text{ to } 5 D_{15}(\text{sub-grade})$ Criteria-3: $D_{50}(\text{blanket}) < 25 \times D_{50}(\text{sub-grade})$ Minimum $E_{v2}$ - determined from 2 <sup>nd</sup> step Plate Load Test on top of compacted blanket layer (Ref : German Code : DIN 18134 – 2001)	30 cm for SQ3, <u>45 cm for SQ2</u>  SQ2/SQ3 are soil below blanket. Compacted upto 100% MDD  Min. $E_{v2}$ – 100 MPa	45 cm for SQ3, <u>60 cm for SQ2</u>  SQ2/SQ3 are soil below blanket. Compacted upto 100% MDD  For new line construction, Min. $E_{v2}$ – 120 MPa As in-situ Assurance test	45 cm for SQ3, <u>60 cm for SQ2</u>  SQ2/SQ3 are soil below blanket. Compacted upto 100% MDD  For new line construction, Min. $E_{v2}$ – 120 MPa As in-situ Assurance Test
Layer 1 : Prepared Subgrade (Good/Imported Soil)	CBR $\geq 6 - 8$ (of compacted soil upto 97%) SQ2/SQ3 & Limit fines 12 – 50% ( SQ1 to be avoided) Plasticity Index $\leq 12$ Compaction : Minimum $E_{v2}$ :	100 cm CBR $\geq 7$ generally, but not < 6 in isolated cases 98% MDD 45 MPa	100 cm CBR $\geq 7$ generally, but not < 6 in isolated cases 98% MDD 60 MPa	100 cm CBR $\geq 8$ generally, but not < 7 in isolated cases 98% MDD 60 MPa
Embankment Fill	CBR $\geq 4 - 5$ (of compacted soil upto 97%) (Organic soils to be avoided)  Minimum $E_{v2}$ : Compaction :	CBR $\geq 5$ generally, but not < 4 in isolated cases For SQ1 soil, CBR $\geq 3$ generally, but not < 2 in isolated cases) 30 MPa 97% MDD	CBR $\geq 5$ generally, but not < 4 in isolated cases 30 MPa 97% MDD	CBR $\geq 5$ generally, but not < 4 in isolated cases 30 MPa 97% MDD
Ground Soil/Sub-soil Strata	Minimum Undrained Cohesion of soil, $C_u = 25$ kPa or Minimum $E_{v2} = 20$ MPa Ground Improvement is required, if $C_u < 25$ kPa, or $E_{v2} < 20$ MPa	Min. $E_{v2} = 20$ MPa	Min. $E_{v2} = 20$ MPa	Min. $E_{v2} = 20$ MPa
Total Thickness (Blanket + Layer 1)	-	130-145 cm	145-160 cm	145 – 160 cm

**Note :** Uniform total thickness of formation layers of 2 m should be provided including blanket, prepared subgrade & top layer of embankment fill etc.

**Fig 10. Formation Profiles and Layers for Heavy Axle Load**

**Single Layer System** (Blanket on Embankment Fill)

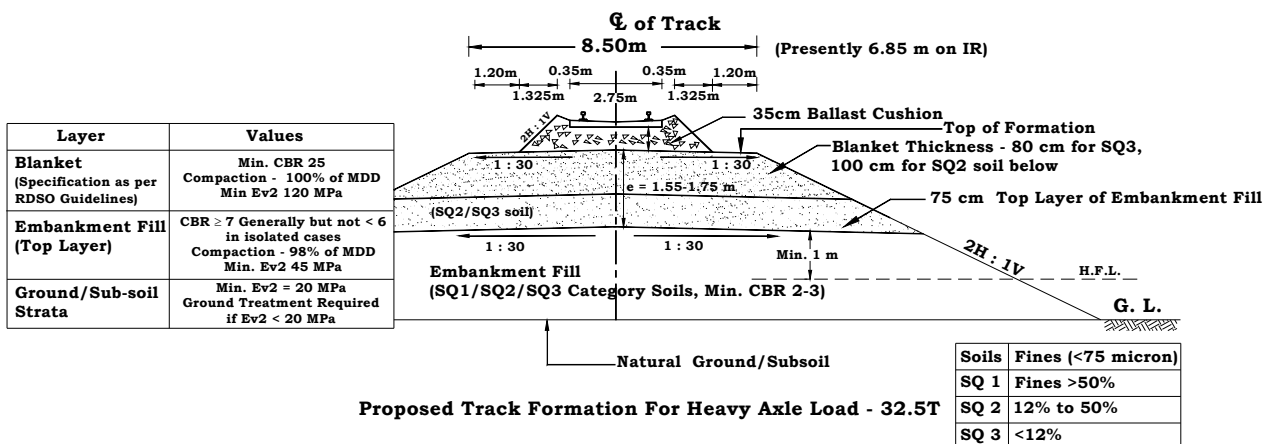
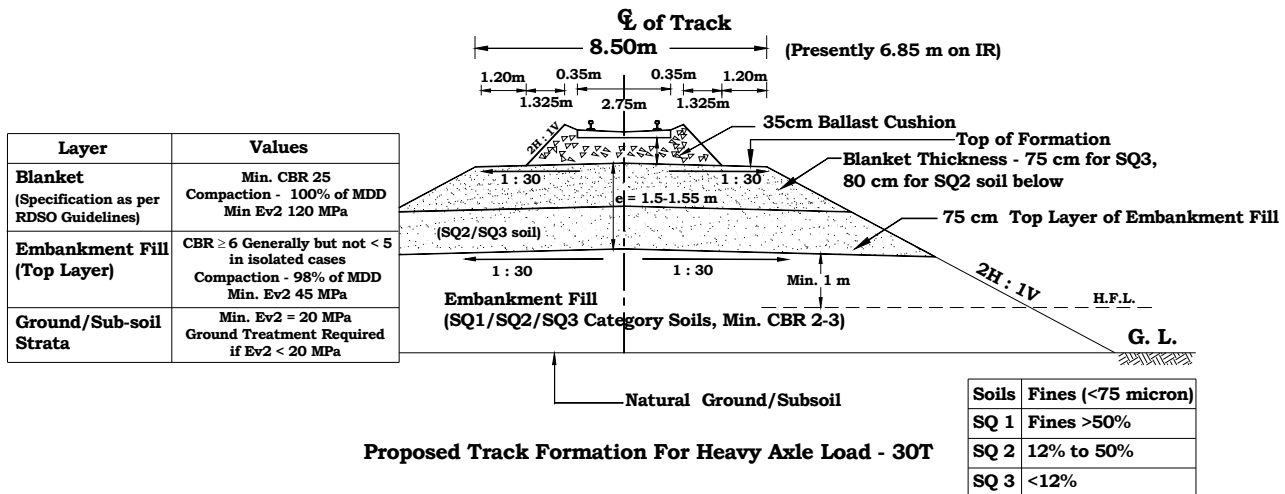
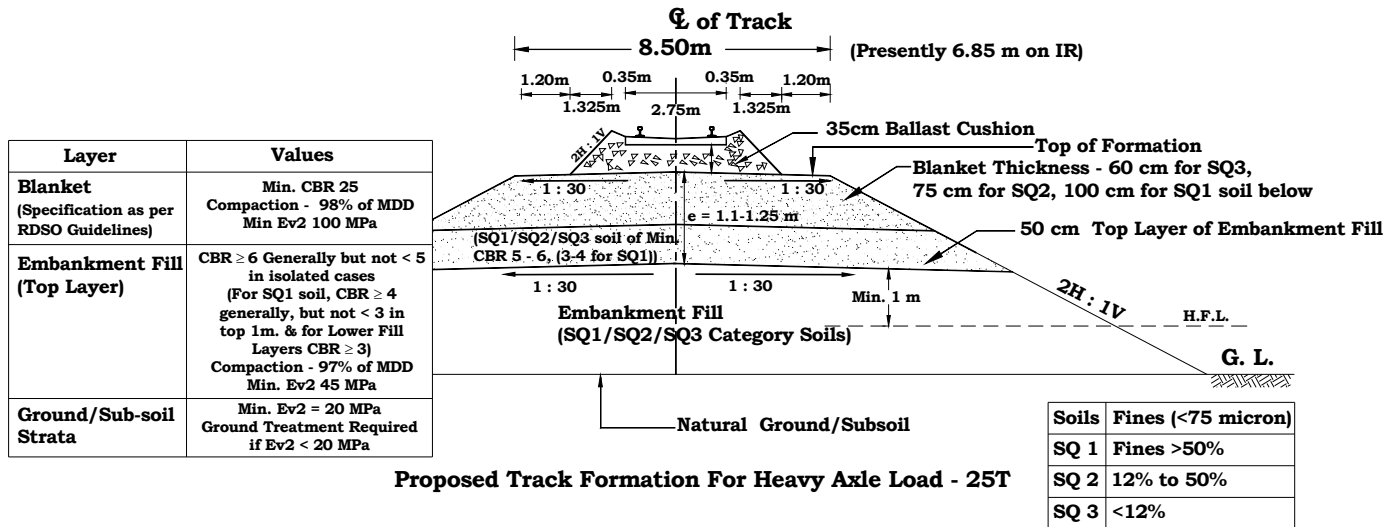

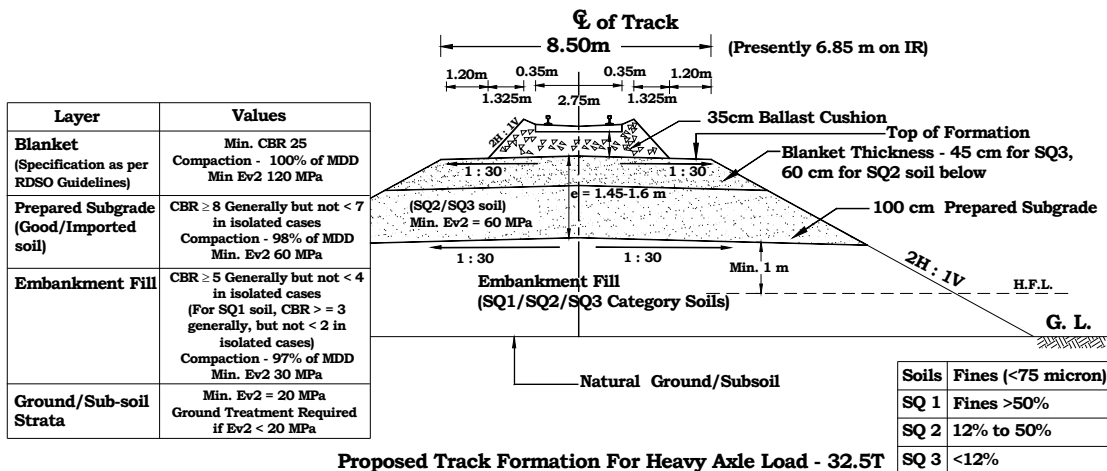
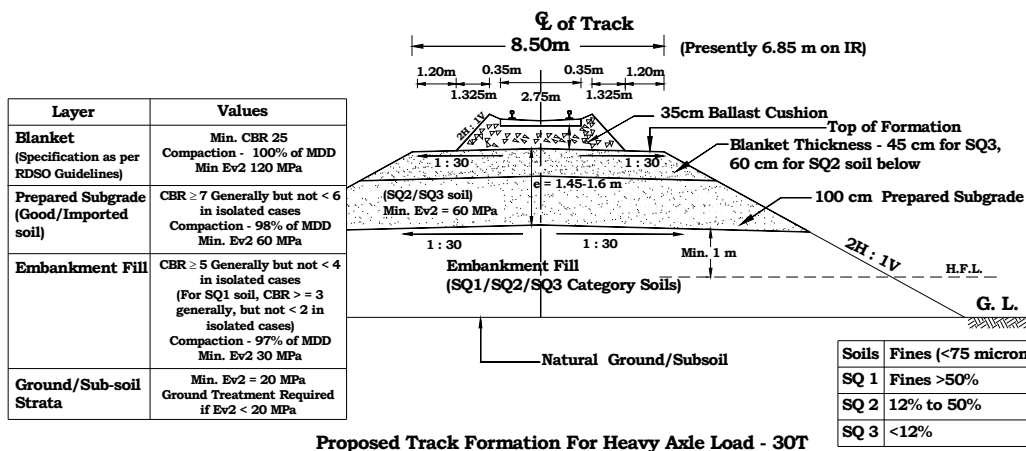
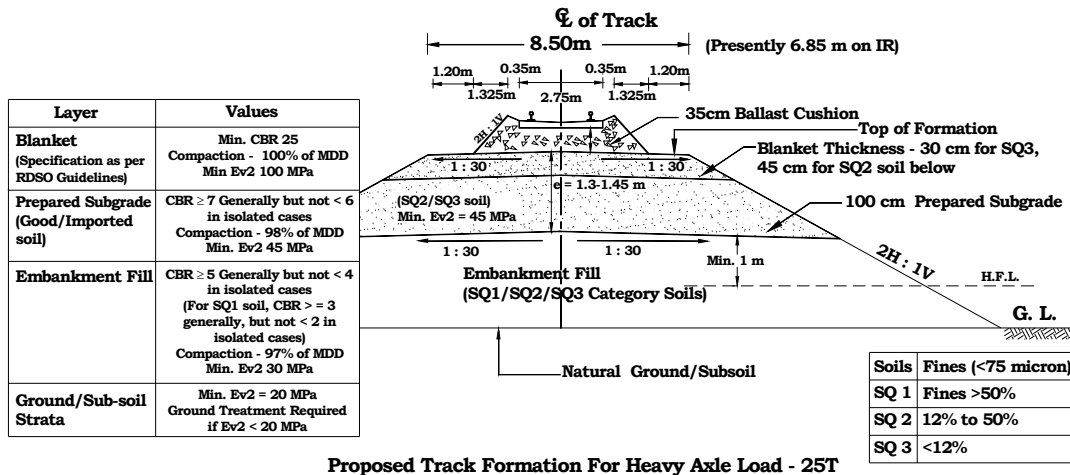

## Two Layer System (Blanket + Prepared Subgrade on Embankment Fill)

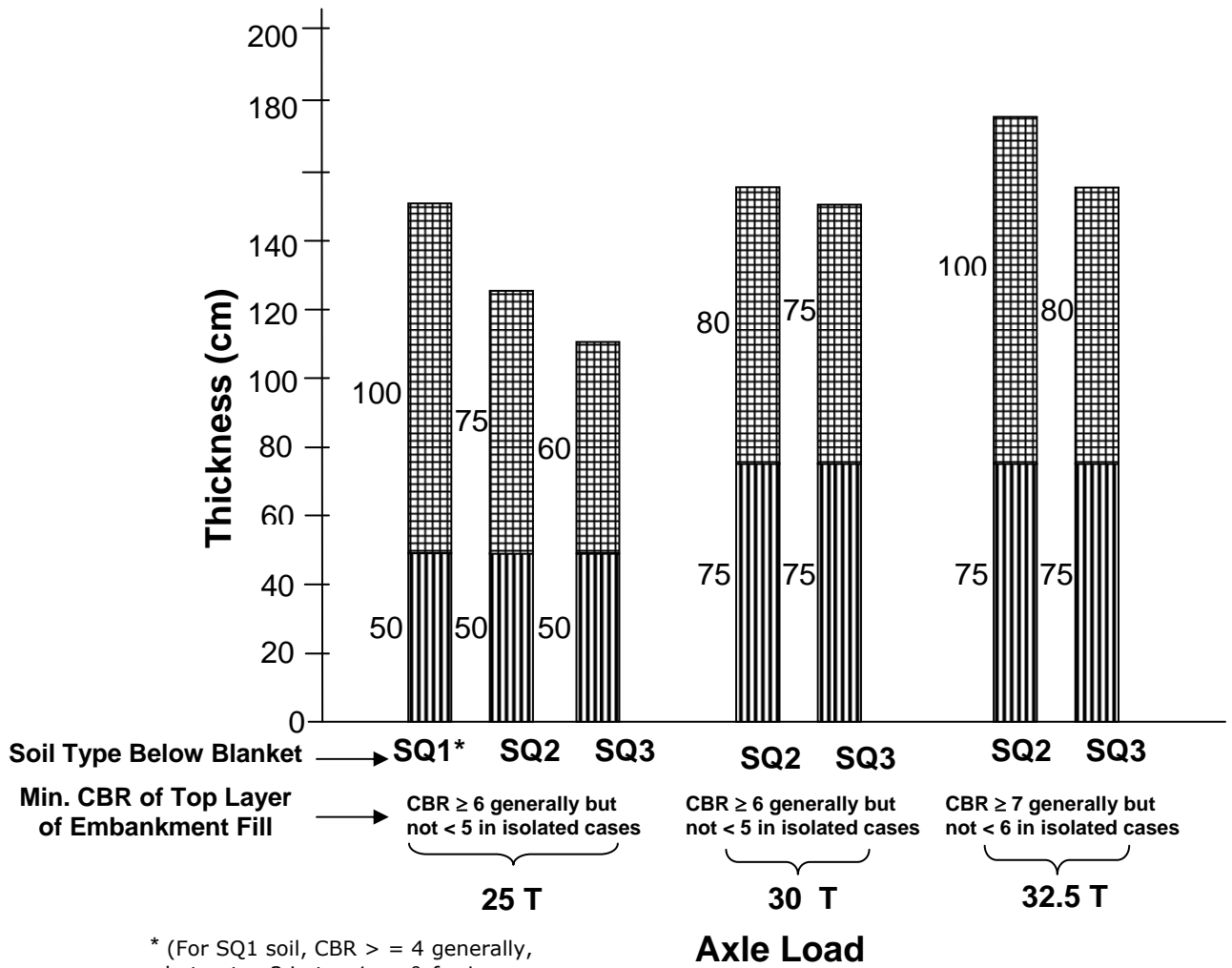

**Fig 11. – Bar Diagrams Showing Formation Layers Thickness**

**Single Layer System**



 Blanket (Min. CBR – 25)  
 Embankment Fill (Top Layer)

Soils	Fines (<75 micron)
SQ 1	Fines >50%
SQ 2	12% to 50%
SQ 3	<12%



\* (For SQ1 soil, CBR > = 4 generally, but not < 3 in top 1 m. & for Lower Fill Layers CBR > = 3)

## Two Layer System (Blanket + Prepared Subgrade on Embankment Fill)

-  Blanket (Min. CBR – 25)
-  Prepared Subgrade (of SQ2/SQ3 Soil)

Soils	Fines (<75 micron)
<b>SQ 1</b>	<b>Fines &gt;50%</b>
<b>SQ 2</b>	<b>12% to 50%</b>
<b>SQ 3</b>	<b>&lt;12%</b>

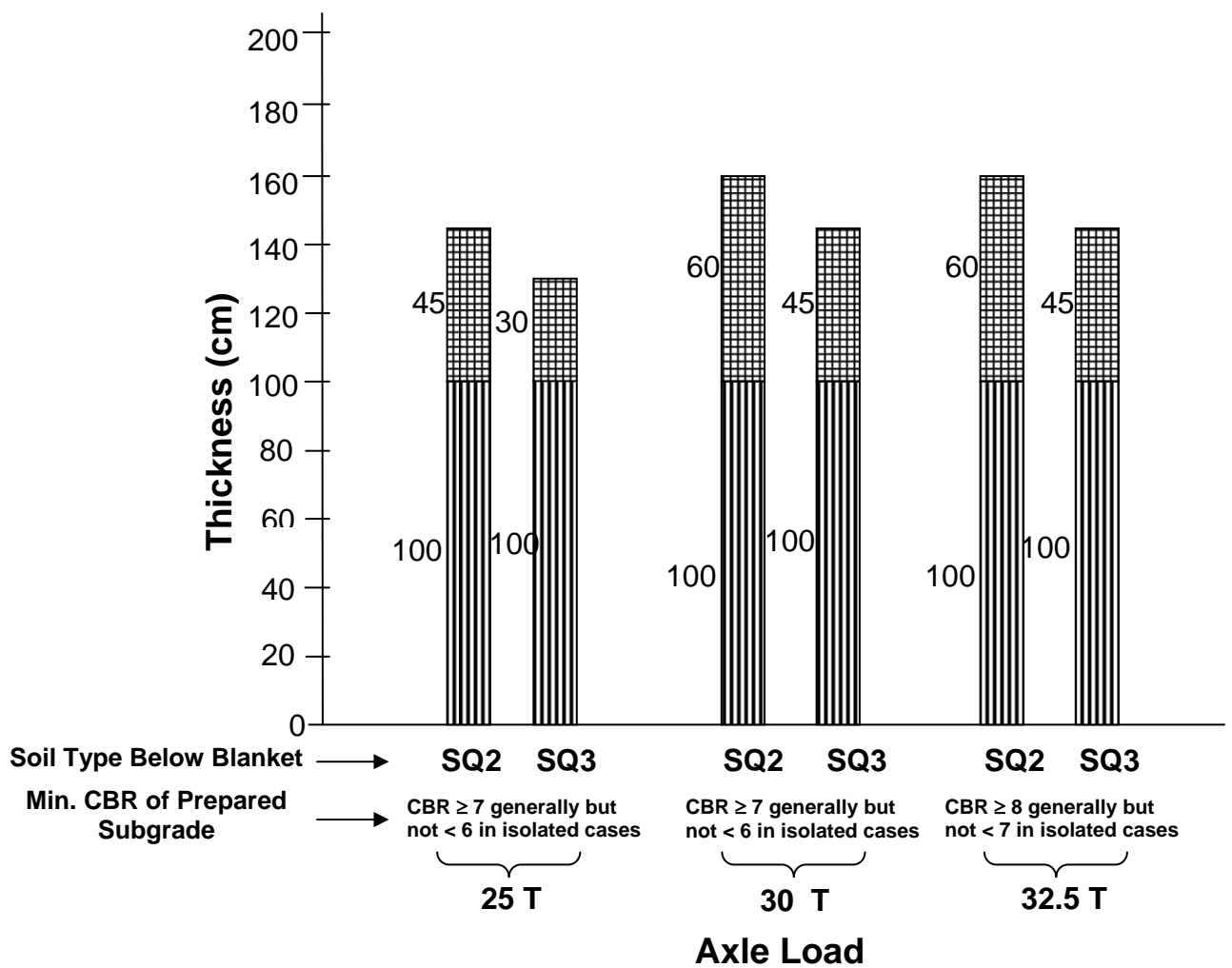

**18. OTHER IMPORTANT GUIDELINES :**

- 18.1 Unsuitable soils, as given in para 8.1 such as organic soils, dispersive soils, CH & MH (in top 3 m of embankment) should not be used in construction of embankment.
- 18.2 **Formation Width :** Currently, the standard width of formation of embankment is 6.85 m for single BG line, as per IRPWM. This is based on the ballast side slope of about 1H:1V and cess width as 90 cm. American Railways adopt ballast side slope of 2H:1V. Japanese Railways adopt cess width of 120 cm. Considering ballast side slope of about 2H:1V, wider cess width of 120 cm for movement of men and material especially for high bank, the recommended formation width for BG track for new lines shall be 8.5 m. In case of DFC double line tracks, the minimum shall be adopted as 13.5 m.
- 18.3 For banks higher than 4.5 metres, suitable slope stability analysis, reinforcement of slopes, plantation of deep root grass and toe wall construction shall be suitably adopted. In case of high bank on soft sub-soil, flatter slope with berm/sub-bank should be provided after slope stability analysis.
- 18.4 Adequate drainage arrangement should be made by providing cross slope at top of formation and side drains/catch water drains, wherever required.
- 18.5 Stable slopes and adequate drainage arrangements in cutting areas should be provided as per details given in 'Guidelines for Cutting in Railway Formations - No. GE: G-2, August 2005'.
- 18.6 For high banks at approaches of rail bridges, providing approach slabs and geogrid layer shall also be considered and adopted. In this regards, recommendations of RDSO report on 'Transition System on Approaches of Bridges' report No. GE: R-50, August- 2005 can be followed.
- 18.7 Reinforced Earth Construction may be adopted wherever steep slope/vertical wall construction is required due to space constraint or otherwise. In this regard, RDSO's report on 'Concept and Design of Reinforced Earth Structures, No. GE-R-63, June 2005' should be consulted.
- 18.8 Adequate erosion control measures on slopes of bank & cutting should be ensured by vegetation on slopes with deep-rooted Vetiver grass & geo-jute textile, if necessary. In areas susceptible to flooding, the sides of an embankment should be protected with a layer of rockfill or stones with an intermediate granular layer upto 1 m above HFL.
- 18.9 At locations, where water table is high and fill-soil is fine-grained, it may be desirable to provide a granular layer of about 30 cm thickness at the base, above sub-soil across the full width of formation. Boulder pitching should be done on embankment slope where
- 18.10 se of geo-synthetics improves the performance of formation. Geo-grid at ballast & blanket interface can reduce blanket thickness requirement. Geo-textile/geo-composite can be provide at the blanket – subgrade interface and/or blanket – prepared subgrade interface for the purpose of separation, filtration & drainage and better performance of the track substructure system as whole. A technical note on the use of various geosynthetic products in trackbed applications is given in Annexure 4.
- 18.11 Apart from the above main & other recommendations, other provisions given in 'Guidelines For Earthwork in Railway Projects', GE:G-1, July 2003 such as construction procedure, drainage, erosion control etc. should also be followed.

## 19.0 BIBLIOGRAPHY AND REFERENCES

- (i) AREMA Manual, 2002
- (ii) Australian Railway (ARTC) Code RTS 3430, March 2006
- (iii) Guidelines of Earthwork in Railway Projects, RDSO, No. GE:G-1, July, 2003
- (iv) Heukelom and Klomp (1962): 'Dynamic Testing as a means of controlling Pavements during and after Construction, Proceedings of 1<sup>st</sup> International Conference on Structural Design of Asphalt Pavements.
- (v) State Of The Art Report On Provision Of Railway Formation, RDSO Report No. GE – 35.
- (vi) State of the Art Report on sub-grade stress and design of track substructure, Civil Engineering Report No. C – 271.
- (vii) IRC:37- 'Guidelines & Design of Flexible Pavement', Indian Road Congress.
- (viii) ORE Reports D – 71, RP – 12 & D-117, RP 28.
- (ix) 'Modern Railway Track', Esveld, Conrad MRT Productions NL, TU Delft, Second Edition 2001.
- (x) 'Procedure For Railway Track Granular Layer Thickness Determination', Dingqing Li, Theodore R. Sussmann Jr., and Ernest T. Selig, Report no. R-898, October, 1996, Assosiation of American Railroads ( AAR), TTC, Pueblo, Colorado, USA.
- (xi) 'Design Issues and Sub-grade Assessment for the Rawang-Ipoh High Speed Track', Sondhi, J.S., Dasari, G. Rao, and Tan, Siew Ann, RailTech Conference, Kuala Lumpur, Malaysia, 2003.
- (xii) Track Compendium– Formation, Permanent Way, Maintenance, Economics, by Dr. Bernhard Lichtberger, 2005, Eurail Press, Hamburg, Germany.
- (xiii) UIC Code 719: 'Earthworks and Track-bed layers for Railway Line', Third ed., 2008

---

## ACKNOWLEDGEMENTS

The Document has been prepared by the team of Geo-technical Engineering Directorate of RDSO, with contributions from Shri S.K. Ojha, SSRE/GE, Shri R. K. Premi, SSRE & Shri G. P. Shukla, SRE. Drawing work has been done by Shri Sushil Kumar, JE-1(Design)/GE.



**Annexure-1****Ground Improvement Techniques/Soft Ground Improvement Methods :**

These techniques can be adopted to improve the ground strength on which the embankment/fills is constructed. The underlying soil for fill is required to satisfy the same basic requirements of a continuous spread foundation system. The underlying soil should have the strength to support the proposed embankment and live loads with an adequate safety factor. In addition, the embankment/fill needs to be designed and constructed such that it can tolerate the projected degree of settlement. It is occasionally necessary to remove and replace portions of weak or highly compressible underlying soil or to improve their characteristics by using stabilisation procedures or controlled construction techniques. Identification of vulnerable conditions of ground which requires improvement can be measured in terms of high content of soft clay having undrained shear strength less than 25 kPa, loose sand strata having N value less than 5, and  $E_{v2}$  (Elastic Modulus of 2<sup>nd</sup> plate load test) assessed less than 20MPa. Controlled construction techniques could include one or combination of the following:

**1. Removal and replacement of weak soil:**

For localised areas with soft soils (having undrained shear strength less than 20 kPa or CBR<3) of limited depth and thickness, removal of unsuitable material and replacement with suitable fill may be carried out. These unsuitable materials were encountered in valleys and low-lying areas and may be replaced with well-compacted suitable fill preferably coarse-grained/sandy soils. Excavation and replacement could be carried out up to 2 m.

The removal and replacement may be required to be carried out even in 'cutting' areas where the naturally occurring soils were found to be of a low shear strength and high moisture content. Subsurface drainage may have to be introduced in most of such areas.

**2. Stage constructions of the fill:**

This technique can enhance the bearing capacity of the sub-soil and provide the site for required construction of embankment up to the design height in the phases/stages with a designed strength of the soil & calculated waiting period for the next loading upon the previous loading.

Stage construction is employed mainly as a means of gradually increasing the shear strength of a soft clay which would otherwise be inadequate to carry the intended embankment load without failure. In stage construction, advantage of increase in shear strength of sub-soil strata due to consolidation by surcharge of embankment loading is taken into account. The gain in shear strength is a function of angle of shearing resistance improved in terms of effective stress parameters and degree of consolidation. The principle of stage construction method is shown in figure below-

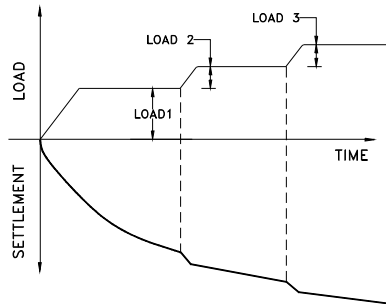

Theoretical basis of design using stage construction method, solved practical examples and instrumentation scheme for monitoring the behaviour of embankment on soft soil are covered in detail in later chapters. Details on this topic is given in 'Guidelines on construction over soft soil' published by Geotechnical Directorate, RDSO.

### 3. Preloading and surcharging :

The preloading technique is a simple one and is an economical method for accelerating consolidation as compared with other methods of improving ground support. However, adequate instrumentations for monitoring the settlements, development and dissipation of pore water pressures is essential for the success of this technique. Preloading is particularly economical technique in the construction of railway fills on soft clays, since, the material can stay in place and need not be relocated.

For low embankment over soft compressible soil where the poor ground is of limited thickness (short drainage path) or is capable of compressing rapidly under load of excess preload fill due to presence of sand lenses, preloading may be resorted. Preloading of soft soils is based on the consolidation concepts, whereby pore water is squeezed from the voids until the water content and the volume of the soil are in equilibrium under the loading stresses imposed by the surcharge. This is usually accompanied by gain in shear strength of soil. To a certain extent, the primary consolidation under final loading can be achieved during construction and hence post construction settlement reduces.

### 4. Installation of vertical drainage system:

Vertical drains are used where preloading alone shall not be efficient. Vertical drains in soft clay accelerate the primary consolidation of clay since they bring about rapid dissipation of excess pore water pressure. Vertical drains have no direct effect on the rate of secondary compression but the early completion of primary consolidation brings about the earlier onset of secondary settlement. Therefore the structures or embankments can be put to use earlier than it would be possible otherwise.

The accelerated rate of gain in shear strength of clay enables the loads to be applied more rapidly than would otherwise be possible. Steep side slopes and avoidance of berms in case of embankments may be possible when sand drains are used. The effectiveness of vertical drains depends mainly on the engineering properties of soils, namely, soil permeability and coefficient of consolidation and their variations in space and time. Vertical drains can be successful in accelerating the rate of consolidation of soft fine-grained soils. They are, however, ineffective in organic soils and highly stratified soils.

Generally the drains are installed by any of these methods depending upon the site conditions and availability of equipment.

Prefabricated vertical PVC drain can be defined as any prefabricated material or product consisting of a synthetic filter jacket surrounding a plastic core. Because of their shape, they are also known as band or wick drain. The details of PVC drains and their installation techniques are given in "Prefabricated PVC Vertical Drainage System for Construction of Embankment on Compressible Soft Soil" Report No. GE-R-68, December 2004.

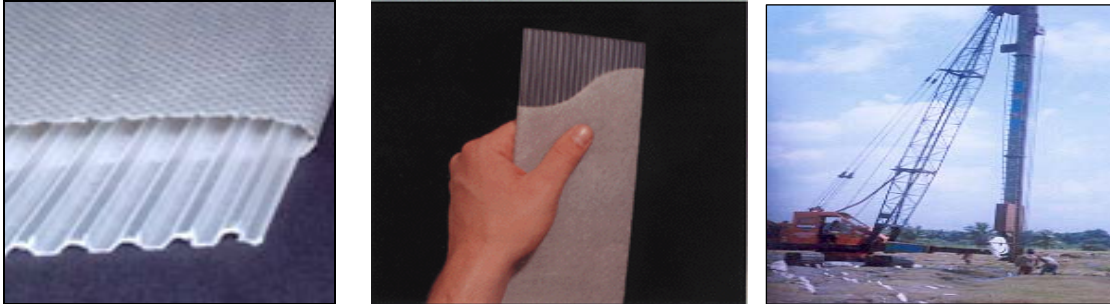

#### 5. **In-Situ Pile/Sand Gravel Compaction Pile/ Stone Columns:**

Granular piles are composed of compacted sand or gravel instead in to the soft clay foundation by displacement method. The term 'granular piles' used in this report refers to these components of compacted gravel and/or sand piles. It is also known as stone columns. The ground improved by by compacted granular piles is termed composite ground. On loading, the pile bulging into the sub-soil strata and distributes the stresses at the upper portion of the soil profile rather than transferring the stresses in to the deeper layer, thus causing the soil to support it.

As a result, the strength and bearing capacity of the composite ground can be increased and the compressibility reduced. In addition, lesser stress concentration is developed on the granular piles. The granular/sand material with higher permeability, these piles could accelerate the consolidation settlement and minimize the post construction settlements.

Stone columns provide path for pore pressure reduction and lateral confinement of soft clay layers, bearing capacity is greatly enhanced, and may be provided in areas where subsoil layers consists primarily of saturated soft clay more than about 3 to 5 m thick and where the required stringent consideration of settlement cannot be satisfied with conventional removal / replacement of soft material. After Stone column treatment, the embankment with non-compressible fill can be constructed to its full height continuously without further stage construction.

#### 6. **Vibro-floatation:**

Various methods are referred for installation of Granular piles have been used all over the world depending on their proven applicability and availability of equipment in the locality. This technique is versatile with respect to range of soils to which it has been applied through soft to firm clays, silts, sands and gravels to brick rubbles and essentially inorganic rubbish. The Vibrofloataion contains an eccentric weight mounted at the bottom on a vertical shaft, directly link to a motor in the body of the machine. The vibrating motion is thus horizontal with the body cycling around a vertical axis. Vibratory energy is applied directly to the ground through the tubular casing of the machine and out put remains constant whatever be the depth of penetration.

## 7. Lime Pile:

It is a kind of vertical drains are used where preloading alone will not be efficient. Such drains in soft clay accelerate the primary consolidation of clay since they bring about rapid dissipation of excess pore water pressure.

Extensive laboratory studies on the use of lime-stabilized piles have been carried out at the Asian Institute of Technology. Additional of 5 to 10% quicklime is the optimum mix proportions for the soft clay. The addition of quicklime increased the unconfined compressive strength to about 5 times and increased the pre-consolidation by as much as 3 times. The coefficient of consolidation also increased by 10 to 40 times and the effective strength parameters also increased, especially the angle of internal friction from 24 degree to 40 degree.

## 8. Lime Slurry pressure Injection/ Ion Exchange

This is the treatment of expansive clays with lime has been found to be effective in reducing the shrinking and swelling characteristics and increasing their shear strength. This may be done in two ways, one by making a bore hole in the ground on Railway formation top to the required depth and then filling the bore hole with the dry lime and then to pour water on the lime filled bore daily for some days, so that lime is carried alongwith the water into the soil seams or voids and there by improving the properties by replacing the exchangeable cat ions of sodium, Magnesium and Potassium etc; The strongly +ve charged ions of calcium present in lime replace the weaker ions of sodium (Na),Magnesium (Mg), and Potassium (K) etc; present in the soil.

The second method is by injecting lime/cement slurry under pressure in a pre-driven hole. The slurry spreads into voids or seams of the surrounding soil structure, forming a network of thin seams of dense lime which over lap. Injection of lime slurry is normally done during dry months of the year when the moisture content of the soil is minimum.

The increase in strength and decrease in compressibility of soft ground results from the reaction of clay with lime and/or cement through the processes of ion exchange and flocculation as well as pozzolanic reactions. The addition of salt, NaCl, may act as catalyser and the ions Cl minus, Na plus, Mg 2plus may have accelerated the pozzolanic reaction which is responsible to neutralize the net negative surface charge of each clay mineral reducing the size of double layer, and thus, increasing the attraction of clay particles leading to improve the ground.

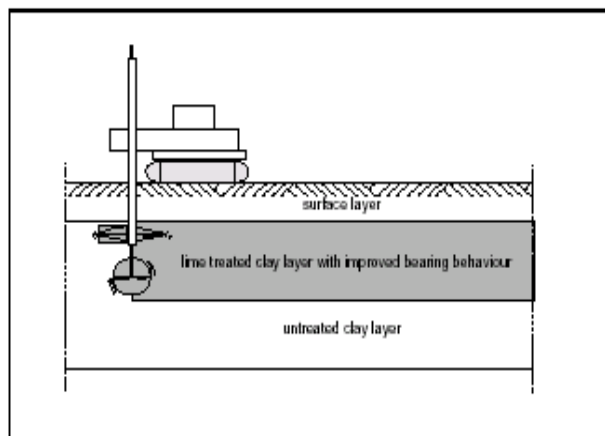

**Fig. Illustrates the principal of lime treatment for large-scale stabilization of subgrade.**

**9. Stir & Mixing:**

Lime/cement mixing method has been used to improve the properties of soils since olden times. Deep stabilisation of soft soils with lime and/or cement stabilized columns has been the subject of research in Sweden, Japan, and other countries for a very long period. The deep mixing (DMM) method originally was developed to improve the soft ground for port and harbor structures. Now this method widely applied to the earthen structures like dams, embankments etc.

This method (DMM) may be classified into two categories as under:

- a) Mechanically mixing method and
- b) Slurry jet mixing

Beside these two one more and effective method cum practice is also popular that is Dry Jet Mixing method (DJM). In this method, the cement or quicklime powder is injected into the deep ground through a nozzle pipe with the aid of compressed air and then the powder is mixed mechanically by rotating wings. This type of prepared material can increased the unconfined compressive strength of improved soil in-situ by 400kPa at 28 days curing.

**10. Sand mat:**

It is a method in which dissipation of excess water from the soft soils by the means of vertical sand drains, horizontal sand drains and the provision of the sand layer at the ground level to improve the bearing capacity as well as the drainage of excess water which is responsible for increasing the pore water pressure within the soil mass.

Some times, when fill material of the embankment is also of poor quality required sand layers of 30cm thick at the interval of 2-3m known as the sandwich construction. This type of construction improves the ground as well as the fill conditions and enhances the slope stability and the strength of the embankment in terms of cohesion.

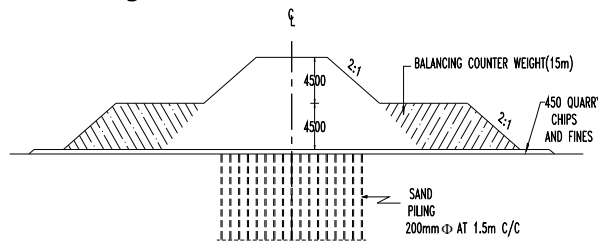

**Sand mat with the help of vertical sand drains/piles**

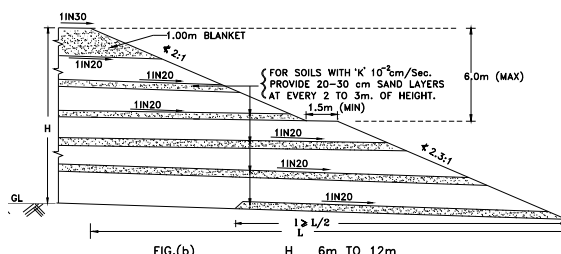

NOTE: FOR BANK OF HEIGHT > 12m PROPER COMPUTATION FOR FAILURES AGAINST SLIPS, SETTLEMENT, ETC. SHOULD BE CARRIED OUT.

**Sand mat with the help of Horizontal sand drains/sandwich system**

## 11. Stabilization & Ground Improvement Methods Using Geosynthetics

Stabilization & Ground improvement techniques using geocell and load transfer platforms, at various locations in the track superstructure are proven to be effective in improving the performance of tracks on soft soils.

Following sections describe the different methods that are currently employed and are in practice to tackle various geotechnical problem on soft soil.

### A. Geocell

To construct embankments on soft soil with inadequate bearing capacity geocell mattress is a unique method of ground improvement. The incorporation of a geocell foundation mattress provides a relatively stiff foundation and maximizes the bearing capacity of the underlying weak soil. The geocell mattress technique is particularly effective with relatively thin soft foundation layers where the ratio of embankment width to depth of soft soils is greater than four.

The geocell foundation mattress is a honeycombed structure formed from a series of interlocking cells. These cells are fabricated in-situ directly on the soft foundation soil using geogrids which are filled with granular material / locally available infill material. Further, when filled with suitable granular materials, geocell acts as a drainage blanket and can be used in conjunction with prefabricated vertical drains to accelerate consolidation.

Geocell is constructed using biaxial and uniaxial geogrids as described below and as shown in Figures below.

- Biaxial geogrids to form the base and a platform on which the cell diaphragms can be fabricated.
- Uniaxial geogrids to form the transverse and diagonal cell diaphragms. These uniaxial grids should have high initial modulus to contain fill as they are placed without allowing large displacements.

The incorporation of geocell mattress creates an embankment foundation with the following characteristics

1. A perfectly rough interface between the mattress and the soft foundation due to the granular fill material partially penetrating the base geogrid layer.
2. A stiff platform to ensure both an even distribution of load onto the foundation and the formation of a regular stress field within the foundation.

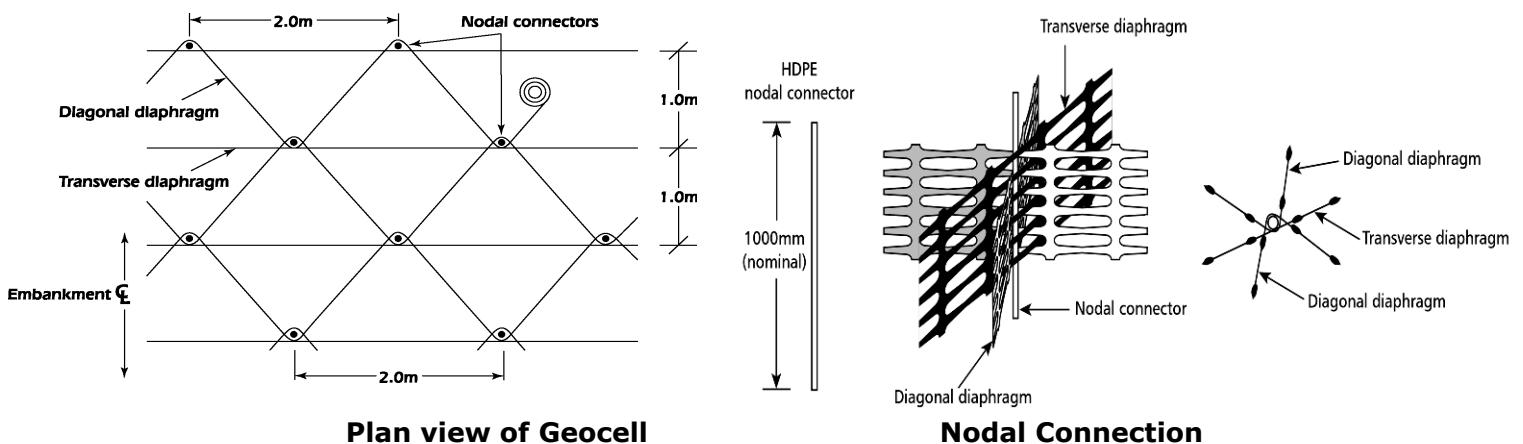



**Geocell – Fabrication**



**Geocell - Filling**

**D. Load Transfer Platform**

The use of stone columns/ piles allows transferring the load of the embankment to the firm stratum below. As a process, the load from the embankment must be effectively transferred to the columns to prevent punching of the columns through the embankment fill creating differential settlement at the surface. Further to achieve soil arching the columns are placed closely for effective load transfer. In order to increase the spacing of columns, to minimize the size of pile caps required to support the embankment and to increase the efficiency of the design, a load transfer platform (LTP) reinforced with geosynthetic reinforcement is used.

A load transfer platform consists of one or more layers of geosynthetic reinforcement placed between the top of the columns and the bottom of the embankment as shown in Figure.

**Design of LTP**

The design of column supported embankments must consider both limit state, and serviceability state failure criteria. The limit state failure mode includes pile group capacity, pile group extent, vertical load shedding, lateral sliding and overall global stability. In addition to limit state analysis, serviceability state designs i.e. strain in the geosynthetic reinforcement and the settlement of the columns should be considered. The strain in the reinforcement used to create the load transfer platform should be kept below maximum threshold to prevent unacceptable differential settlement at the top of the embankment. Settlement of the columns must also be analyzed to assure that unacceptable settlement of the overall system does not occur.

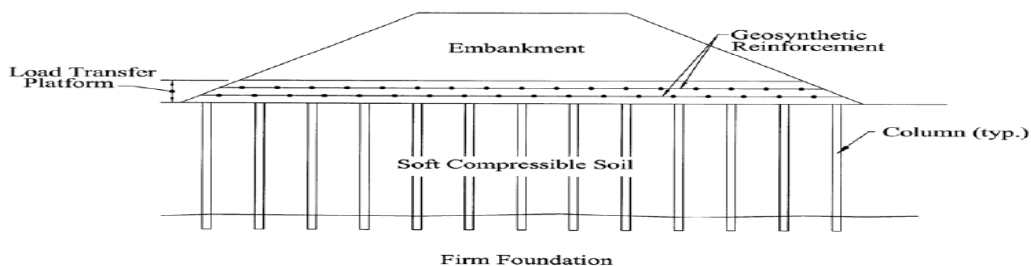

**Schematic Sketch of a Load Transfer Platform**

**Annexure-2****QUALITY ASSURANCE TESTS****1. Standard Test Procedure For California Bearing Ratio (Laboratory Method)**

(Ref: BIS Code – IS : 2720 (part 16) – 1979 Laboratory Determination of CBR)

**California Bearing Ratio**

California Bearing Ratio (CBR) test is a penetration test developed by the California State Highway Department of USA for the evaluation of subgrade strengths for roads and pavements.

California Bearing Ratio (CBR) is defined as the Ratio of Force per unit Area required to penetrate a soil mass with a circular plunger of 50 mm diameter at the rate of 1.25 mm/minute to that required for corresponding penetration of a standard material. The test is arbitrary and results may not be directly related to fundamental properties governing the strength of soils such as cohesion, angle of internal friction etc. Schematic of CBR Test shown below:

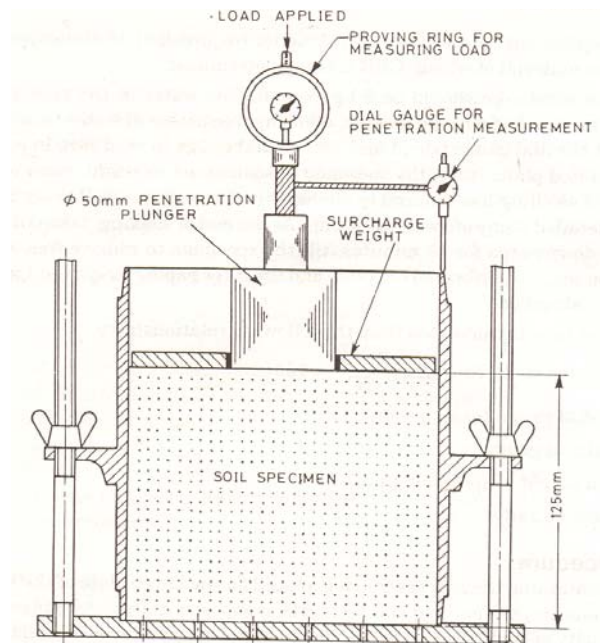
**Apparatus:**

- i) CBR mould 150 mm diameter and 175 mm high with detachable perforated base plate. (Net capacity is 2250 ml).
- ii) Collar 50 mm high.
- iii) Penetration plunger - 50 mm diameter.
- iv) One annular and a few slotted surcharge masses 2.5 kg each.
- v) Rammer 2.6 kg with 310 mm drop and 4.89 kg with 450 mm drop.
- vi) Steel rod 15-20 mm in dia and 400 mm long.
- vii) Cutting edge.
- viii) Loading machine of approximately 5000 kg capacity, fitted with a calibrated proving ring giving a constant rate of penetration of about 1.25 mm/minute.
- ix) Penetration measuring 2 dial gauges accurate to 0.01 mm.
- x) Soaking tank of pan, drying oven, dishes and calibrated measuring jar.



- xi) Swelling gauge consisting of a perforated plate with an adjustable extension stem.
- xii) I.S. Sieves 4.75 mm and 19 mm.
- xiii) Straight edge, mixing basin.
- xiv) Filter paper
- xv) Weights

### **Preparation of test specimen**

The test may be conducted on undisturbed as well as disturbed (remoulded) soil specimen which may be compacted statically or dynamically.

### **Undisturbed soil specimen**

Undisturbed soil specimen shall be obtained from the field in natural condition. For this, use 127.3 mm high mould and attach the steel cutting edge to its one end. Push the mould gently into the ground. When the mould is full of soil, it shall be taken out carefully. The top and bottom surfaces are then trimmed flat so as to achieve the correct length of specimen for testing. The specimen is then sealed with paraffin wax on both sides of the mould so as to preserve it with the natural moisture content.

### **Remoulded specimen (From disturbed sample)**

When undisturbed specimen is not available, the specimen can be prepared by remoulding the disturbed soil sample. It can be prepared on maximum dry density of soil determined by compaction test. The water content used for compaction should be at optimum moisture content.

Remoulded specimens are prepared in the laboratory by compaction. The test material should pass 19 mm I.S. sieve and retained on 4.75 mm sieve.

## **TEST PROCEDURE**

### **1. Soaking of remoulded specimen:**

Weight the mould with base plate and the specimen. Keep the filter paper on the specimen and place the perforated top plate with adjustable stem over the specimen. Keep the mould in a tank in which water is filled for soaking. Apply weights to produce a surcharge equal to the weight of base material and pavement to the nearest 2.5 kg on the compacted soil specimen. The whole mould and weights shall be immersed in a tank of water allowing free access of water to top and bottom of the specimen. The tripod for the expansion measuring device shall be mounted on the edge of the mould and the initial dial gauge reading recorded. This set up shall be kept as such undisturbed for 96 hours noting down the readings every day against the time of reading. A constant water level shall be maintained in the tank throughout the period.

At the end of the soaking period, the final reading of the dial gauge shall be noted, the tripod removed and the mould is taken out of the water tank.

The free water collected in the mould shall be removed and the specimen allowed to draining downward for 15 minutes. After draining out water, the weights, the perforated plate and the top filter paper shall be removed and the mould with the soaked soil sample shall be weighed and the mass recorded.

## 2. Penetration Test:

The mould containing the test specimen is placed on the lower plate of the testing machine with the base plate in position and the top surface exposed. Surcharge mass is placed on the specimen. If the specimen has been soaked previously, the surcharge shall be equal to that use during the soaking period. To prevent upheaval of soil into the hole of the surcharge weights, 2.5 kg annular weight shall be placed on the soil surface. The plunger shall be seated under a load of 4 kg so that full contact is established between the surface of the specimen and the plunger. Load shall be applied to the penetration plunger so that the penetration is approximately 1.25 mm per minute. Reading of the load shall be taken at penetrations of 0.0, 0.5, 1.0, 2.0, 2.5, 4.0, 5.0, 7.5, 10.0 and 12.5 mm.

After the completion of the test, the plunger is raised and the mould is detached from the loading equipment. About 20 to 50 g of soil shall be collected from the top 30 mm layer of specimen for water content determination.

### LOAD PENETRATION CURVE

The load penetration curve is drawn as shown in Fig.2. The curve is generally convex upwards, although the initial portion of the curve may be concave upwards due to surface irregularities. A correction shall then be applied by drawing a tangent to the upper curve at the point of contraflexure. The corrected curve shall then be taken to be this tangent plus the convex portion of the original curve with the origin of strains shifted to the point where the tangent cuts the horizontal strain axis as illustrated in Fig. below:

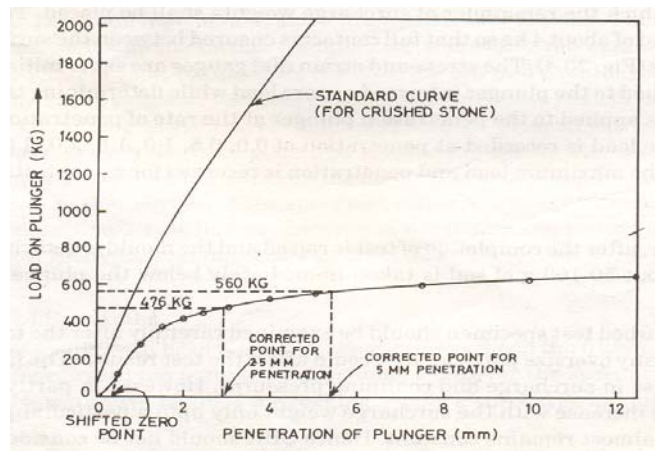

**Load Penetration Curve for a CBR Test**

### DETERMINATION OF CBR

Corrected load value shall then be taken from the load penetration curve corresponding to the penetration value at which CBR is desired. The CBR is then determined as follows:-

$$\text{CBR} = P_T / P_s \times 100$$

Where,

$P_T$  = Corrected load corresponding to the chosen penetration from the load penetration curve,  
 $P_s$  = Standard load for the same depth of penetration as for  $P_s$

The CBR values are usually calculated for penetration of 2.5mm and 5mm. Generally, the CBR value at 2.5 mm penetration will be greater than that at 5mm penetration and in such a

case; the former shall be taken as the CBR value for design purpose. If the CBR value corresponding to a penetration of 5mm exceeds that for 2.5mm, the test shall be repeated. If identical results follow, the bearing ratio corresponding to 5mm penetration shall be taken for design.

### **Standard Loads for CBR test**

<b>Penetration Depth (mm)</b>	<b>Unit Standard Load (kg/cm<sup>2</sup>)</b>	<b>Total Standard Load (kg)</b>
2.5	70	1370
5.0	105	2055
7.5	134	2630
10.0	162	3180
12.5	183	3600

Test Observations are recorded in the table as given in the code.

### **Report**

The CBR value shall then be reported correct to the first decimal place. The details shall be reported in prescribed proforma:-

CBR of specimen at 2.5 mm penetration -  
 CBR of specimen at 5 mm penetration -  
 CBR of specimen at .....Penetration -  
 Results of repeat test, if conducted :

## **2. STANDARD TEST PROCEDURE FOR PLATE LOAD TEST**

*(Ref: German Code - DIN 18134: 2001- Determining The Deformation And Strength Characteristics Of Soil By Plate Load Test)*

Test in which a load is applied in increments to a soil sample using a circular loading plate and a loading device, released in decrements, and the entire process is repeated. The average normal stress below the plate,  $\sigma_0$ , is plotted against the settlement,  $s$ , for each load increment so as to obtain a load settlement curve.

### **Strain Modulus**

The strain modulus,  $E_v$ , is a parameter expressing the deformation characteristics of a soil, and is calculated taking values from the load-settlement curve obtained from the first and second loading cycle, from the gradient of the secant between points  $0.3 \times \sigma_{0max}$  and  $0.7 \times \sigma_{0max}$ .

**General Test Conditions**

- a) The plate loading test may be carried out on coarse grained and composite soils as well as on stiff to firm fine grained soils. Care shall be taken to ensure that the loading plate is not placed on particles larger than approximately one quarter of its diameter.
- b) In the case of rapidly drawing equigranular sand or soil which has formed a surface crust, has been softened or has been otherwise disturbed in its upper zone, the plate loading test shall be conducted with the disturbed soil being removed. The density of the soil under test shall, as far as possible, be uniform throughout.
- c) For fine grained soils (e.g. silt, clay), the plate loading test can only be carried out and evaluated satisfactorily if the soil is stiff to firm in consistency. In case of doubt, the consistency of soil under test shall be determined at various depths up to a depth equal to the diameter of loading plate,  $d$ , below ground level.

**APPARATUS:**

- (a) **Reaction Loading System:** The reaction loading system shall produce a reaction load which is at least 10 kN greater than the maximum test load required and may be loaded in a truck or trailer or any other object of sufficient mass.
- (b) **Plate Loading Apparatus:** It consists of loading plate, an adjustable spirit level, and a loading system with hydraulic pump, hydraulic jack assembly and high pressure hose.
- (c) **Devices for measuring the load applied:** The load on the plate is best measured by means of a strain gauge with a limit of error of 1% which shall be fitted between the loading plate and piston.
- (d) **Settlement measuring device:** For measuring the settlement of the loading plate, a contact arm assembly shall be used. This consists of a frame supported at three points, a vertically adjustable, torsion proof, rigid contact arm, and a displacement transducer or dial gauge.
- (e) **Programmable pocket calculator:** Suitable for calculating quadratic equations.
- (f) **Loading plates** of 300 mm and 600 mm diameter.

**TEST PROCEDURE:****(i) Test Area Preparation**

A test area sufficiently large to receive the loading plate shall be levelled using suitable tools (e.g. steel straight edge or trowel) or by turning or working the loading plate back and forth. Any loose material shall be removed.

**(ii) Setting up the plate loading apparatus**

The loading plate shall lie in full contact with the test surface. A spirit level shall be fitted to the upper face of the plate and when the test area is inclined, adjusted accordingly. The piston of the hydraulic jack shall be placed centrally on and at right angles to the loading plate beneath the reaction loading system and secured against tipping. The minimum clearance between loading plate and contact area of the reaction load shall be 0.75 m for a 300 mm plate, 1.10 m for a 600 mm plate and 1.30 m for a 762 mm plate. The reaction load shall be secured against displacements at right angles to the direction of loading.

**(iii) Arrangement for settlement measuring device**

The contact arm assembly shall be positioned so that its supports are located 1.5 m from the centre of the loading plate. The dial gauge or displacement transducer shall be set up vertically. When placing the loading plate, care shall be taken to ensure that the stylus of

the contact arm can be passed into the rectangular opening without hindrance and positioned centrally on the plate.

#### (iv) Preloading

Prior to starting the test, the strain gauge and the dial gauge or displacement transducer shall be set to zero and the plate preloaded for about 30 seconds. The load applied shall correspond to normal stress of  $0.01 \text{ MN/m}^2$  when using a 300 mm or a 600 mm plate and to a normal stress of  $0.005 \text{ MN/m}^2$  when using a 762 mm plate. The reading of the gauge or transducer at this load shall be taken as zero reading.

#### (v) Determining the strain modulus

To determine the strain modulus,  $E_v$ , the load shall be applied in not less than six stages, in approximately equal increments, until the required maximum normal stress is reached. Each increase in load (from stage to stage) shall be completed within one minute. The load shall be released in stages, to 50% and 25% of the maximum load and then to the load corresponding to the zero reading. Following that a further 2<sup>nd</sup> loading cycle shall be carried out in which the load is to be increased only to the penultimate stages of the first cycle. When testing soil, the time interval between the applications of each load increment shall be 2 minutes. For testing of granular layer, one minute is sufficient.

To determine the strain modulus, a 300 mm loading plate shall be used and load is increased until a settlement of 5 mm or a normal average stress below the plate of  $0.5 \text{ MN/m}^2$  is reached. If the required settlement is reached first, the normal average stress measured at this stage shall be taken as maximum stress.

### EVALUATION AND REPRESENTATION OF RESULTS

- (a) **Load settlement curve:** For each load increment, the average normal stress,  $\sigma_0$ , and the associated reading,  $M$ , shall be recorded and the stress shall be plotted against the settlement. A smooth curve shall be drawn through measuring points for each cycle.
- (b) **Calculation of strain modulus:** Calculation of the strain moduli of the first loading and loading cycle shall be smooth load-settlement curves. These shall be expressed by calculating the settlement,  $s$ , at the centre of the loading plate using relation :

$s = a_0 + a_1 \times \sigma_0 + a_2 \times \sigma_0^2$  where  $\sigma_0$  = Average normal stress below the plate in  $\text{MN/m}^2$   
 **$a_0, a_1$  &  $a_2$**  = Factors in  $\text{mm/MN}^2/\text{m}^4$

For determination of the factors, a value of  $s$  equal to zero shall be ignored. The strain modulus,  $E_v$ , shall be calculated using the following equation :

$$E_v = 1.5 \times r \times 1 / (a_1 + a_2 \times \sigma_{0\max})$$

Where,

$\sigma_0$  = Average normal stress below the plate in  $\text{MN/m}^2$

$a_1, a_2$  = Factors in  $\text{mm/MN}^2/\text{m}^4$

$r$  = Radius of loading plate in mm, and

$\sigma_{0\max}$  = Maximum average normal stress in  $\text{MN/m}^2$

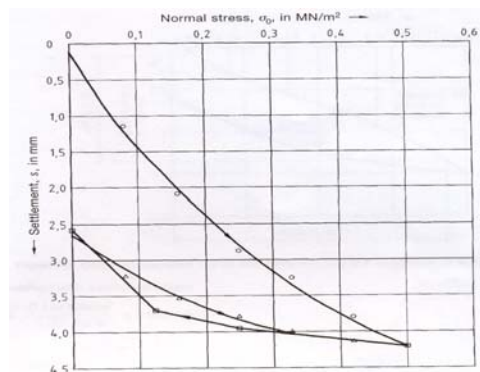

**FIG. :** Load-Settlement Curve for determining the Strain Modulus

### 3. STANDARD TEST PROCEDURE FOR LABORATORY COMPACTION TEST

[ As per IS: 2720 (Part 8) – 1983 ]

Compaction is the process of densification of soil by reducing air voids. The degree of compaction of a given soil is measured in terms of its dry density. The dry density is maximum at the optimum water content. A curve is drawn between the water content and dry density to obtain the maximum dry density and optimum water content.

$$\text{Dry density} = M / V (1+w)$$

Where,

M = total mass of soil

V = volume of soil

w = water content

#### **APPARATUS**

1. Cylindrical metal compaction mould  
Capacity : 1000 cc with dia 100 mm + 0.1, 2250 cc with dia 150 mm + 0.1  
Internal diameter : 100 mm + 0.1, 150 mm + 0.1  
Internal effective height of mould: 127.3 + 0.1 mm  
Collar: 60 mm high  
Detachable base plate
2. Rammer Mass: For Heavy compaction = 4.9 kg, Dia: 50 mm
3. IS sieve: 19 mm & 4.75 mm
4. Oven: Thermostatically controlled to maintain a temperature of 105<sup>0</sup> to 110<sup>0</sup> C
5. Weighing Balance: sensitivity - 1 g for capacity 10 kg,  
0.01g for capacity 200 g
6. Steel straight edge of about 300 mm in length with one edge levelled.
7. Gradation jar
8. Large mixing pan
9. Spatula

#### **PREPARATION OF SAMPLE**

1. Break the clods of soil sample as received from the field and remove the organic matter like tree roots, pieces of bark etc. from the sample.
2. Dry the sample in the air. In wet weather, use drying oven but the temperature of the sample should not exceed 60<sup>0</sup> C.
3. Take a representative portion of air-dried soil material and large enough to provide about 6 kg of material passing a 19-mm IS sieve (for soils not susceptible to crushing during compaction, or about 15 kg of material passing a 19-mm IS sieve (for soils susceptible to crushing during compaction)
4. Sieve above material through 19 mm & 4.75 mm IS sieve.
5. Sieve above material through 19-mm IS sieve and if soil retained on this sieve is more than 5%, use mould of 2250 cm<sup>3</sup> and reject soil retained on 19-mm sieve after its proportion of the total sample has been recorded.
6. If percentage retained on 4.75 mm IS sieve is greater than 20, then use mould of 2250 cm<sup>3</sup> otherwise use small mould of 1000 cm<sup>3</sup>.
7. Determine the ratio of fraction retained and that passing 4.75 mm IS sieve to access the density of the soil.

8. Mix the soil sample retained on 4.75 mm sieve and that passing 4.75 mm sieve for further testing.
9. Mix the sample thoroughly with a suitable amount of water depending on the soil type. :-
  - (a) Sandy and gravelly soil: 3 to 5%
  - (b) Cohesive soil: 12 to 16% approx.
10. Store the soil sample in a sealed container for a minimum period of 16 hours.

### **PROCEDURE**

1. Clean and dry the mould and base plate and apply a thin layer of grease on the inside the mould.
2. Weigh the mould to the nearest 1 gram. Attach the collar to the mould and place on a solid base.
3. Compact the moist soil in to the mould in five layers of approximately equal mass, each layer being given 25 blows from 4.9 kg rammer dropped from a height of 450 mm above the soil. The blows should be distributed uniformly over the surface of each layer.
4. Remove the collar and trim off the excess soil projecting above the mould by using straight edge. Take the weight of mould with compacted soil in it.
5. Remove 100 g of compacted soil specimen for the water content determination.
6. Add water in increment of 1 to 2 % for sandy and gravelly soils and 2 to 4 % for cohesive soils.
7. Above procedure will be repeated for each increment of water added. The total number of determination shall be at least four and moisture content should be such that the OMC at which MDD occurs, is within that range.

### **PRECAUTIONS**

1. Ramming should be done continuously taking care of height of 450 mm free fall accurately.
2. The amount of soil taken for compaction should be in such a way that after compacting the last layer, the soil surface is not more than 5 mm above the top rim of the mould.
3. Weighing should be done accurately.

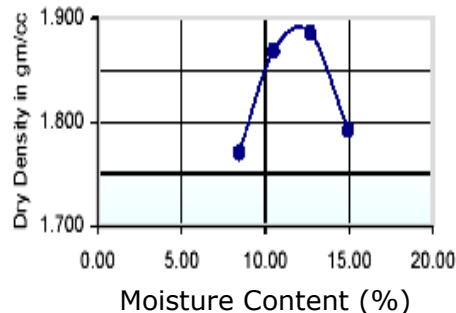

**Curve for Dry Density v/s Moisture Content**

**Annexure – 3****FORMATION STRESSES - FINITE ELEMENT ANALYSIS**

Formation stresses at various depths have been determined by various researchers. A Study done by IIT, Delhi using Finite Element Analysis for 32.5 t axle load is summarized. The details of the proposed track sections (hereby referred as Model 1,2 & 3) for are given in Table 1 & Fig. 1 & Fig. 2.

In the analysis, 60 kg rail section has been used which, modelled as rectangular section keeping the base width and the moment of inertia same. Thus, an equivalent height of rail section was calculated. The static wheel load of 243.75 kN (including dynamic augment of 1.5) was applied from the centre line. The elastic model was used for the analysis of the track.

Axle load	= 32.5 T
Dynamic Augment	= 1.5
Dynamic Load	= 48.75 T
Wheel Load, W1, W2	= 24.375 T

The details of model 1, 2 & 3 represent proposed single layer blanket system over subgrade, two layer system (blanket, prepared subgrade over subgrade) and three layer system (blanket, granular crusher run, prepared subgrade over subgrade) are given in table below.

**3-D FEM Modelling**

In 3-D Finite Element Modelling, a 3-dimensional model of limited dimensions of track has been drawn in computer using FEM Software 'ABACUS'. This geometry of model is given with different coordinates of points & dimensions of layers. Material properties such as elastic modulus, poisson's ratio, unit weight etc. of different materials viz. rail, sleeper, ballast, blanket, subgrade etc. are given as input to the software. Boundary conditions are surfaces are defined and wheel load are applied on the model. The Model is solved using the software and graphs of different results for stresses, deformation etc. are viewed/plotted using the various options given in the software.

**Assumptions :**

1. Materials such as soil, prepared subgrade, blanket, ballast, etc. are elastic.
2. Rail section has been assumed rectangular having same EI value as of the I –section.
3. Due to symmetry only half of the track is modelled.
4. Elastic modulus of different material has been assumed as per specified value of CBR values of different layers.
5. Elastic modulus of other items such as rail, sleeper, ballast, blanket has been taken as the available values in literature.



**Details of Track Model (Model 1, 2 & 3)**

Track Component		Details	Material Parameters
Rail		Base Width = 150 mm Height = 172 mm Moment of Inertia (MOI) = 3055 cm <sup>4</sup> Base Area = 76.86 cm <sup>2</sup> Weight = 60.34 Kg	E = 200 x 10 <sup>3</sup> MPa μ = 0.30
Sleepers		Material = Concrete Base Width = 250 mm Height = 210 mm Top Width = 150 mm Length = 2750 mm MOI = 15290 cm <sup>4</sup> Bottom bearing Area = 76.86 cm <sup>2</sup> Weight = 285.4 Kg Spacing = 60 cm	E = 30 x 10 <sup>3</sup> MPa μ = 0.20
Ballast		Depth = 30 cm	E = 130 MPa, μ = 0.37
Blanket	Model 1	Depth = 100 cm	E = 140 MPa
	Model 2	Depth = 60 cm	E = 140 MPa
	Model 3	Depth = 30 cm	E = 140 MPa
Top Soil	Model 1		Depth = 75 cm E = 55 MPa
	Model 2		Depth = 100 cm E = 67 MPa
	Model 3	Crusher Run	Depth = 70 cm E = 100 MPa
		Prepared Subgrade	Depth = 50 cm E = 67 MPa
Bottom Soil	Model 1		Depth = 125cm E = 50 MPa
	Model 2		Depth = 140 cm E = 50 MPa
	Model 3		Depth = 150 cm E = 50 MPa

**Stresses & Deformations for Model 1,2 & 3**

Parameters	Model 1	Model 2	Model 3
Stress at top of ballast (kPa)	1160	1670	1610
Stress at top of blanket (kPa)	115.3	114.3	138.8
Stress at top of top soil (kPa)	53.0	65.8	92.5
Stress at top of middle soil (kPa)	-	-	53.0
Stress at top of bottom soil (kPa)	45.1	46.8	47.6
Displacement at top of ballast (mm)	2.57	2.75	2.67
Displacement at top of blanket (mm)	2.203	2.38	2.30
Displacement at top of top soil (mm)	1.66	2.02	2.12
Displacement at top of middle soil (mm)	-	-	1.64
Displacement at top of bottom soil (mm)	1.04	1.19	1.27

Variation of vertical stress with depth in single, two layer & three layer system for 32.5T Axle load (From FEM Analysis by IIT Delhi)

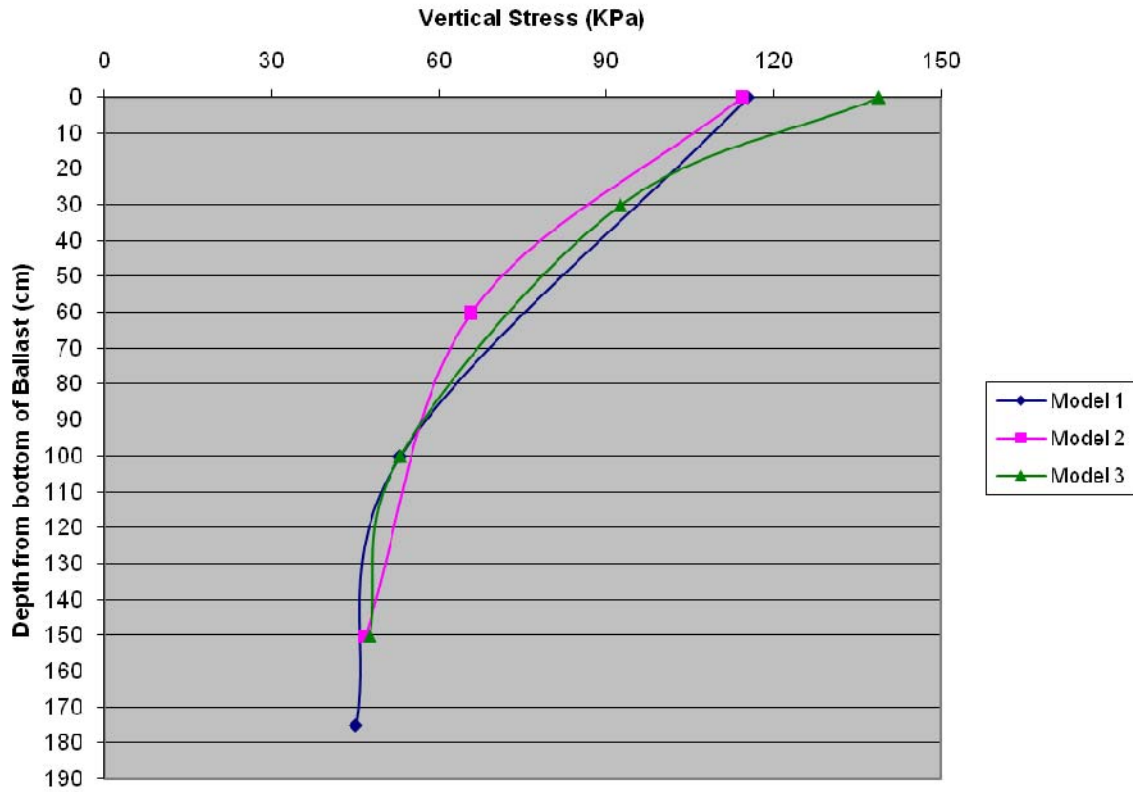

Fig. : FE Analysis ( 3-D Models)- Stress Variation with depth.

**Annexure – 4****GEOSYNTHETICS IN TRACKBED APPLICATIONS**

Under the dynamic conditions caused by pulsating train loading, the marginal or poor subgrade soils suffer from severe mud pumping and subsidence. Load-Bearing capacity failures also occur and such tracks require frequent maintenance. The use of Geosynthetics helps to achieve higher efficiency and better performance of such modern-day railway track super structures.

When a properly designed geosynthetic is installed within the track structure four principal functions are fulfilled. These are

- Separation, in new railway tracks, between soil subgrade and formation and in rehabilitated railway tracks, between formation and ballast
- Filtration of soil pore water rising from the soil subgrade beneath the geosynthetic, due to rising water conditions or the dynamic pumping action of the wheel loadings, across the plane of the geosynthetic;
- Reinforcement in order to contain the overlying ballast aggregate and stabilizing the blanket layer.
- Lateral drainage of water entering from above or below the geosynthetic within its plane leading to side drains.

The geosynthetics most suited for performing the above mentioned functions are geotextiles and geogrids or a composite of both depending on the application.

**Geotextiles:**

In the present application Geotextiles act as a separator, drainage material, filter and as reinforcement. To efficiently perform the above functions, the geotextile must satisfy the following criteria:

- To withstand the installation stresses the geotextile requires adequate puncture strength, burst strength, grab strength, tear strength and resistance to UV light degradation with negligible strength loss.
- The properties of geotextile which are essential to withstand static and dynamic loads, high pore pressures, and severe abrasive action to which it is subjected during its useful life are puncture resistance, abrasion resistance and elongation at failure.
- It must be resistant to excessive clogging or blinding, allowing water to pass freely across and within the plane of the geotextile, while at the same time filtering out and retaining fines in the subgrade. Properties required are: cross-plane permeability (permittivity), in-plane permeability (transmissivity) and Apparent Opening Size (AOS).
- It must be resistant to rot, and attacks by insects and rodents. It must be resistant to chemicals such as acids and alkalis present in the soil.

**GEOGRIDS**

Existing commercial geogrid products include punched and oriented geogrids, woven geogrids, welded geogrids, and geogrid composites. Punched and oriented geogrids are formed using a polymer sheet that is punched and drawn in either one or two directions for improvement of engineering properties. Woven geogrids are manufactured by weaving polymer fibres, typically polypropylene or polyester, that can be coated for increased abrasion resistance. Welded geogrids are manufactured by welding the junctions of woven segments of extruded polymers. Geogrid composites are formed when geogrids are

combined with other products to form a composite system capable of addressing a particular application.

Punched and oriented geogrids can be divided into two broad categories based upon their formation and principle application, uniaxial and biaxial. Punched and oriented geogrids that are pre-tensioned in one direction are called uniaxial geogrids and are typically used in geotechnical engineering projects where the stresses are oriented in one direction like reinforced earth and retaining walls applications. Punched and oriented geogrids that are pre-tensioned in two directions are referred to as biaxial geogrids and are typically used in pavement, railway tracks and many other applications where the direction of principle stress is uncertain.

In the present application, the direction of stresses is uncertain due to dynamic loads which emphasize the use of (punched and oriented) biaxial geogrids. Punched and oriented geogrids have shown good performance when compared to other types like woven, welded and knitted geogrids for pavement reinforcement applications. (Cancelli et al. 1996, Miura et al. 1990, and Webster 1993).

### Mechanism of Geogrids

Geogrids stabilize the existing track bed layers by improving lateral confinement and bearing capacity, increasing resilient modulus and decreasing differential settlements.

Geogrids stabilize through two possible mechanisms (Holtz, R.D et al, 1995).

- a) Lateral restraint of the ballast and formation through interlock (between aggregate and geogrid), and friction (between the soil and the geogrid)
- b) Sub grade restraint/ Increase in the system bearing

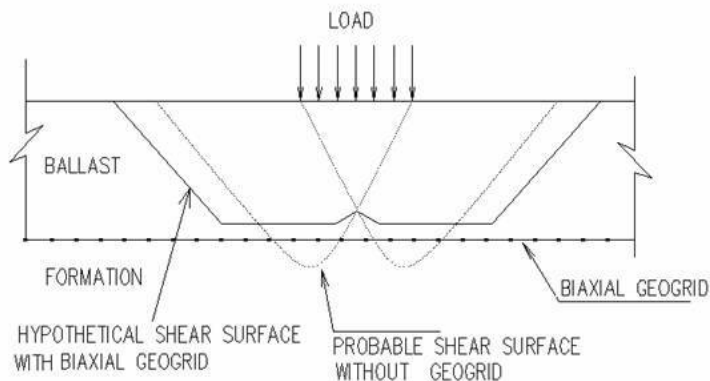
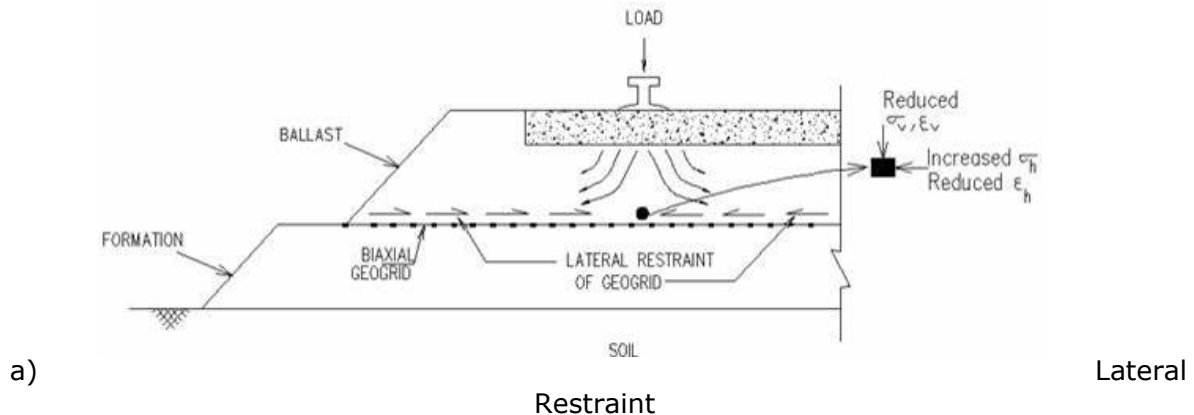

b) Bearing Capacity Increase

Since the specifications are in evolving stage, these shall be adopted as per the industry standards currently being considered and current standards on Foreign Railways, material imported and locally manufactured in the country and as per sufficient experience gained during field trials on Zonal Railways under observation of RDSO.

The detailed specifications for use of geosynthetics for railway formation is under preparation at RDSO and likely to be issued shortly.

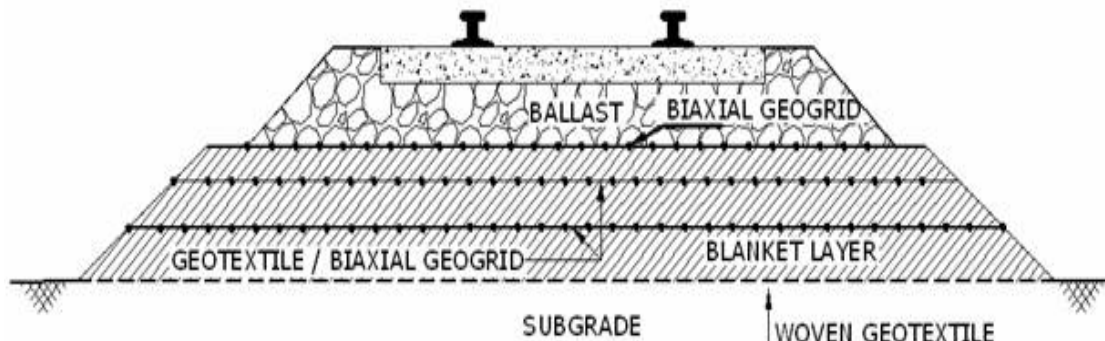
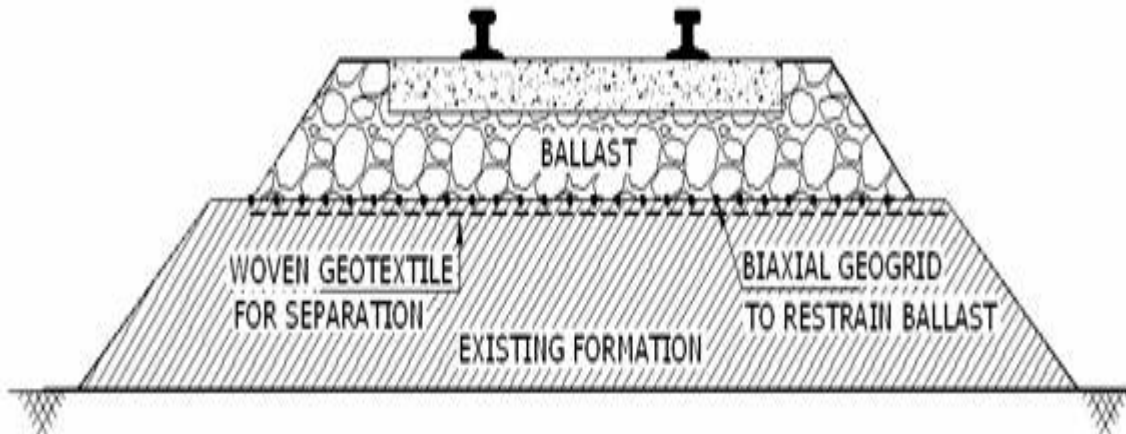

NOTE : THE GEOTEXTILE USED SHALL BE POLYESTER MULTIFILAMENT WOVEN GEOTEXTILE

WOVEN GEOTEXTILE FOR SEPARATION/FILTRATION

**Appendix- A****CODAL PROVISIONS OF TRACK BED LAYERS ON WORLD RAILWAY SYSTEMS****1.0 European Railways (UIC)****1.1 Provisions :**

As per UIC code 719 R, 2008, minimum thickness (e) of track bed layers is given by the formula:

$e = E + a + b + c + d + f$  ; details as per figure below :

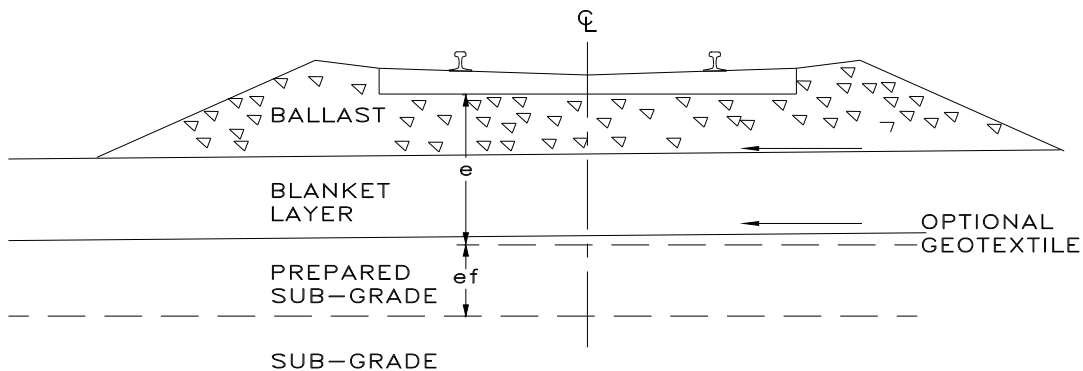

where,

- e = Total depth of ballast & blanket
- E = Factor depending upon **quality class of soil** used in prepared subgrade
- a = Factor depending on UIC groups based on **GMT**
- b = Factor depending on **type & length of sleeper**
- c = Factor depending on different **working conditions** on existing lines
- d = Factor depending on **axle load** of hauled vehicle
- f = Factor depending on inclusion of **geo-textile** based on quality class of prepared sub-grade.

The values of the above factors, as given in the UIC-719R code are as under :

E = 0.70 m For QS1 soils used as prepared sub-grade  
 E = 0.55 m For QS2 soils used as prepared sub-grade  
 E = 0.45 m For QS3 soils used as prepared sub-grade  
 (Thickness of prepared sub-grade varies from 35 cm to 50 cm)

a = 0 For UIC groups 1-4  
 a = -0.10m For UIC groups 5 & 6

b = 0 For wooden sleepers of length 2.60m  
 b = (2.50-L) / 2 For concrete sleepers of length L (b in m, L in m, if L > 2.50m)

c = 0 For usual dimensions  
 c = -0.05 m For difficult working conditions on existing lines

d = 0                      For 200 kN axle load  
d = 0.05 m                For 225 kN axle load  
d = 0.12 m                For 250 kN axle load

f = + Track bed must include a geo-textile for soil of QS<sub>1</sub> or QS<sub>2</sub> class

Soil Quality Class QS<sub>0</sub>, QS<sub>1</sub>, QS<sub>2</sub> & QS<sub>3</sub> are defined in UIC Code are as under :

Soil Type (Geo-technical Classification)		Soil Quality Class
0.1	Organic soils	QS <sub>0</sub>
0.2	Soft soils containing more than 15% fines <sup>(1)</sup> with high moisture content: therefore unsuitable for compaction.	
0.3	Thixotropic soils <sup>(2)</sup> (e.g. quick clay)	
0.4	Soils containing soluble material (e.g. rock salt or gypsum)	
0.5	Contaminated ground (e.g. industrial waste)	
0.6	Collapsible soils or Expansive soils	
1.1	Soft soils containing more than 40% of fines <sup>(1)</sup> (except for soils classified under 0.2)	QS <sub>1</sub>
1.2	Rocks which are very susceptible to weathering, e.g. : - Chalk with $\rho_d < 1.7 \text{ t/m}^3$ and high friability - Marl - Weathering shale	
1.3	Soils containing 15% to 40% of fines <sup>(1)</sup> (except for soils classified under 0.2)	QS <sub>1</sub> <sup>(3)</sup>
1.4	Rocks which are moderately susceptible to weathering, e.g. - Chalk with $\rho_d < 1.7 \text{ t/m}^3$ and low friability - Un-weathered shale	
1.5	Soft rock e.g. Micro-deval wet (MDE) > 40 and Los Angeles (LA) > 40	
2.1	Soils containing from 5 to 15% of fines <sup>(1)</sup>	QS <sub>2</sub> <sup>(4)</sup>
2.2	Uniform soil containing less than 5% of fines (1) (Cu ≤ 6) Moderate hard rock, e.g. : If 25 < MDE ≤ 40 and 30 < LA ≤ 40	
3.1	Well graded soils containing less than 5% of fines <sup>(1)</sup> Hard rock, e.g. : If MDE ≤ 25 and LA ≤ 30	QS <sub>3</sub>

- 1) These percentages are calculated from particle size distribution analysis undertaken on material passing a 60 micron sieve. The percentages indicated have been rounded down (particles vary slightly vary from one Railway to another); they may be increased by upto 5% if sufficiently representative number of samples are taken.
- 2) Certain Railways sometimes include these soils in quality class QS<sub>1</sub>.
- 3) These soils can come under quality class QS<sub>2</sub> if the hydro-geological and hydrological conditions are good.
- 4) These soils can come under quality class QS<sub>3</sub> if the hydro-geological and hydrological conditions are good.

## 1.2 UIC Specifications of Blanket Material :

- i) Blanket material must be a well graded sandy-gravel material ( $C_u > 6$  and  $C_c$  between 1 & 3).
- ii) It should be sufficiently durable e.g. Los Angeles value less than 20 or 25.
- iii) Some railways require sandy gravel to contain at least 30% of crushed stone.
- iv) It should satisfy Terzaghi Filter criteria with sub-grade soil.
- v) If blanket layer is in contact with fine grained (silty or clayey) sub-grade, it should have about 20% fine sand (particle size less than 0.2 mm).

## 2.0 American Railways (AREMA)

American Railway Engineering and Maintenance-of-way Association (AREMA) Manual of Railway Engineering 2002, recommends use of 12 inches ballast and 12 inches sub-ballast on main track. Use of soils with Plasticity Index  $> 12$  for a depth of 4 feet below sub-ballast should be avoided, if possible.

### 2.1 AREMA Specification for Sub-ballast :

- i) Material to be used is similar to highway bases and sub-bases such as crushed stone, natural or crushed gravel, natural or manufactured sands, crushed slag etc.
- ii) Sub-ballast shall be granular material so graded as to prevent penetration into sub-grade and penetration of ballast into sub-ballast zone.
- iii) Filter principles should be used in drainage to the grading of sub-grade.
- iv) Maximum size of sub-ballast should not exceed maximum size of ballast.
- iv) Not more than 5% of the sub-ballast should pass the no. 200 sieve (60 micron).

## 3.0 Australian Railways (ARTC Code RTS 3430)

Australian Railway Track Corporation provides 15 cm blanket/ capping material (for 25 T axle load ) with over 0.5 m of sub-grade having CBR values more than 8 or over 1 m of sub-grade if its CBR is in range of 3 to 8, as shown in Figure below:

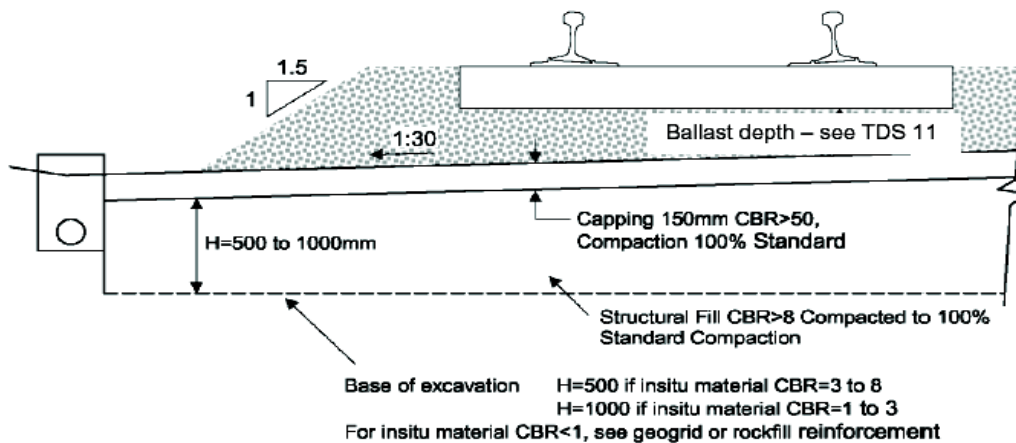

**Note:** Construction using full depth of capping material instead of two materials will reduce total depth by about 30%



**3.1 General Requirements of Blanket Material :**

Material proposed for capping shall be a well graded natural or artificially blended gravel/soil. It shall have sufficient fines to permit it to be compacted to high densities by static or vibratory steel-tired rollers or by ballasted pneumatic-tired rollers. Materials such as natural ridge gravel free from vegetable matter, ripped sandstones with low clay content and crushed and blended tough, durable rock or slag, have been found to meet material properties of this specification.

**3.2 Material Properties :**

Natural gravels may be combined to provide material which conforms to this specification. Crushed rock shall include such added material as necessary for the combined material to satisfy the requirements of this specification.

**3.3 Particle Size Distribution :**

Material shall be well graded with typical particle size distribution as follows :

AS Sieve	Percentage Passing Nominal Size (20mm)
53 mm	100
37.5 mm	100
26.5 mm	100
19.0 mm	95-100
9.5 mm	-
4.75 mm	-
2.36 mm	30-80
0.075 mm	6-10

**3.4 Atterberg Limits :**

- Liquid Limit : Maximum 30 (35 for arid areas)
- Plastic Limit : Maximum 20
- Plasticity Index : 2 -10 (2 -15 for arid areas)
- Linear Shrinkage : Maximum 3%

**3.5 Maximum Dry Density :** Minimum 2.0 t/cum

**4.0 Granular Layer Thickness based on ORE D117 Report and on Various Railways**

The relation between granular layer thickness versus sub-grade modulus according to ORE D117 for various Railways is reflected in the adjoining Figure.

(Ev2) or CBR values or soil types are correlated to the granular layer thickness required.

As can be seen, the required thickness e= (ballast + sub-ballast), for given sub-grade properties, differs on various Railways.

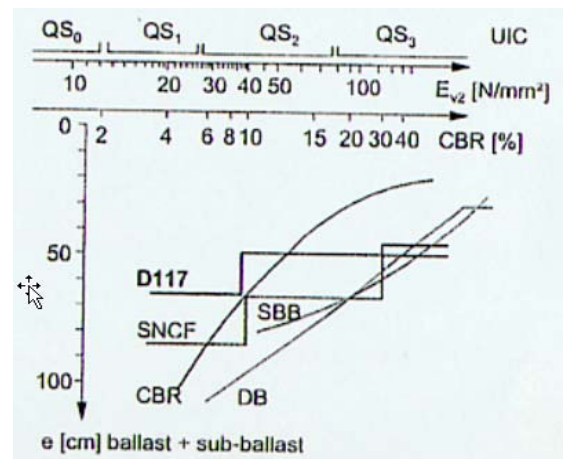

**Fig. Ballast + Sub-ballast thickness versus sub-grade CBR/ Modulus (based: ORE D117, Design Handbook RP28)**

**Appendix- B****Minutes of the Committee Meeting on 'Formation Specifications for Heavy Axle Load' on 8 & 9.10.2009 at Mumbai & Railway Board's letter of Approval**

Vide Railway Board letter no. 2007/CE-1/Geotech/02 dated 06.08.2009, a Special Committee was nominated to deliberate upon RDSO's draft 'Guidelines and Specifications for Formation of Heavy Axle Load', July 2009 consisting of :

1. CAO(C)/WR – Presiding Officer
2. Sr. EDGE/RDSO, Convener Member
3. CAO(C)/NCR – Member
4. CAO(C)/SR – Member
5. Representative from RVNL – Member

Following were present in the committee meeting on 8<sup>th</sup> & 9<sup>th</sup> Oct., 2009.

1. Sh. S. K. Jain, CAO(C)/WR
2. Sh. J.C. Parihar, Sr. EDGE/RDSO
3. Sh. R. Ramanathan, CAO(C)/SR
4. Sh. C.P. Tayal, CAO(C)/NCR

Sh. J.S. Mehrok, GM/RVNL could not attend the meeting. However, cost of soil and blanket from different projects, executed by RVNL was sent to the committee for discussion. Soil test results (CBR values) and rates of soils and blanket material were also received from Southern Railway.

Two terms of reference, as per Board's letter and views of the Special Committee thereon are as under:

- 1. To deliberate upon the cost aspects and availability of soils to be used as per the Specifications and Guidelines for Heavy Axle Loads, proposed/submitted by RDSO.***

**Views of the Special Committee:**

- i) Committee has noted that the blanket thickness, as recommended in Guidelines & Specifications of Formation for Heavy Axle Load has been reduced in comparison to that given in RDSO's previous Guidelines of Earthwork, July 2003. This will result in saving in formation cost, as blanket is generally costly material.
- ii) Specification of blanket material is improved over earlier specifications in view of heavy axle loads. Since blanket material thickness is reduced now, availability of blanket material in lesser quantity will be easier. Mechanized production of blanket material by blending/crushing may be necessary to achieve specification as natural material; available from single source may not meet the specifications. Mechanized production is also commonly adopted in construction of road pavements / highways by Organization such as NHAI.
- iii) Considering the cost aspects and availability of materials, 3-layer system of formation is not considered necessary.
- iv) CBR values of commonly available soils in India are gone through. From the test results available with GE directorate of RDSO and Southern Railway, it is observed that CBR values

are more than 3 and will meet the soil specifications for embankment fill except in costal region (CH & MH types of soils).

- v) Committee feels that there may be some locations where blanket material is available at far away distance which will make it very costly. However, it is still considered worth even at such higher cost, taking into account long lasting advantages. In order to reduce the overall cost, the quantity of such materials can be reduced and more of less costly materials can be blended through mechanized blending so as to achieve finished product of requisite specification.
- vi) Rates of earthwork and blanketing for different sites/ project works in RVNL and Southern Railway have been examined. Rate of earthwork is ranging from Rs. 20 /cum (Railway Soil), Rs. 83/ cum to Rs.750/ cum and rate of blanketing is ranging from Rs. 182/ cum to 1050/ cum. This indicates that the rates of earth work and blanketing are varying vastly from site to site. Furthermore rate of blanketing on the average is about Rs. 500/- to Rs.700/-per cum. It is felt that the rate of blanketing in Eastern region may be still higher, which may be collected and kept on record.

**2. Give suggestions, if any for New Lines/Doubling/GC Works to be carried out on IR, for existing axle loads in the range 22.5t(7.54t.m) to 25t (8.25 t/m)**

**Views of the Special Committee:**

For New Lines/Doubling/GC Works to be carried out on IR, for existing axle loads in the range 22.5t (7.54t.m) to 25t (8.25 t/m), No dilution in formation specification should be made and kept as same as that for the 25 T Axle load, since these lines may be upgraded in due course to carry 25t axle load and providing additional blanket thickness and upgrading formation at later stage is very difficult and costly. Hence, Formation specifications for 25 t axle load should be adopted for New Lines/Doubling/GC Works also meant for axle loads in the range 22.5t (7.54t.m) to 25t (8.25 t/m).

**Recommendations :**

1. **Availability of Materials:** After going with the documents available with the committee, all members are of the view that there will be no difficulty in getting adequate quality soil for construction of formation all over India. More over soils to be used in formation in new specifications are almost same as in previous RDSO Guidelines GE:G-1 2003 and change is only in defining the soils with CBR values similar to Road Organizations. Blanket Specifications are slightly improved over previous one but with lesser requirement in quantity. This can be mechanically produced, as done in Highway Organization like NHAI.
2. **Cost of earthwork and blanketing:** Cost of earthwork would vary from region to region but **no significant addition in cost of earthwork in formation is envisaged on account of new specifications.** The rate of blanket material will go up primarily due to mechanical production and blending. However, on a holistic view, the increase in cost may not be very significant especially when compared to the additional advantage accrued with such better specification.
3. Formation Specifications for New Lines/Doubling/GC Works to be carried out on IR, for existing axle loads in the range 22.5t to 25t should be also be kept as same as those for 25 T as per new specifications.

-----

**GOVERNMENT OF INDIA/BHARATSARKAR  
MINISTRY OF RAILWAYS/RAIL MANTRALAYA  
(RAILWAY BOARD)**

Dated: 26<sup>th</sup> Oct'2009  
Rail Bhawan, New Delhi

No.2007/CE-I/Geotech/02

Sr. Executive Director,  
Geo-Technical Engineering,  
R.D.S.O. Manaknagar,  
Lucknow.

**Sub: Guidelines & Specifications for formation of Heavy Axle Load (HAL)**

- Ref: (i) Your letter No.RS/G/108/HAL dated 12.10.2009  
(ii) Final Minutes of the Special Committee dated 09.10.09  
(iii) Guidelines and Specifications for formation of HAL (July 2009)

After considering the views of the Special Committee and matters brought out Board (ME) has approved the Guidelines and Specifications for Formation of HAL (July'2009), under ref. (iii) above, with following condition and necessary corrections:

- (i) This is to be put to use only on new works and would not apply to on going project.
- (ii) To this may be first tried for a year and half to get the field appreciation and correction, if any.
- (iii) Three layer system of formation design, based upon cost aspects and availability of materials, should be deleted from the final guidelines being circulated.

The Final Guidelines & Specification fro formation of Heavy Axle Load should be circulated by the RDSO to Zonal Railways and PSU (Railways) with a hard & soft copy for Railway Board, by 31<sup>st</sup> Oct'2009. Its implementation on railways may please be monitored closely and reported through monthly PCDO. Zonal Railways may be asked to report the difficulties if any, in adoption of the new specification.



(Arun Kumar Shrivastava)  
Executive Director  
Civil Engineering (B&S)-II  
Railway Board

**Appendix – C****MECHANICAL PRODUCTION OF BLANKET MATERIAL**

If, naturally available materials do not meet the desired specifications, blanket material can be produced mechanically by crushing or blending method or combination of these two methods. Detail of these two methods are given below :

**1. Crushing Methodology:**

In the event of non-availability of natural source of blanket material, depending on the proximity of project site from the parent rock/boulder sources, it may be decided to crush the rock/boulder in order to produce crushed blanket material. Salient features of this methodology are:

- Crushed blanket material may be produced as sole product or in conjunction with ballast or any other nominal size.
- Trials and permutations of feed speed, crushing cycle, sieve combinations may be required to arrive at the required particle size gradation.
- It is possible to achieve near total produce of desired gradation through production cycle management. Alternately, it may be possible to get by-products of other sizes in the desired proportion and blanket material as main produce or vice-versa.
- Optimisation of production rates and costs can be achieved by controlling the output at each sieve stage.
- It is ideal to mix the required quantity of water for OMC (accounting for loss/gain of moisture due to weather conditions) at the crusher plant and transport the material in wet condition.
- Quarry dust or natural by-product of production of higher size coarse aggregates may themselves be suitable for use as blanket material. In all such cases, where large scale crushing is taking place for production of ballast, trials may be conducted to arrive at ideal particle size gradation of the by-product also.

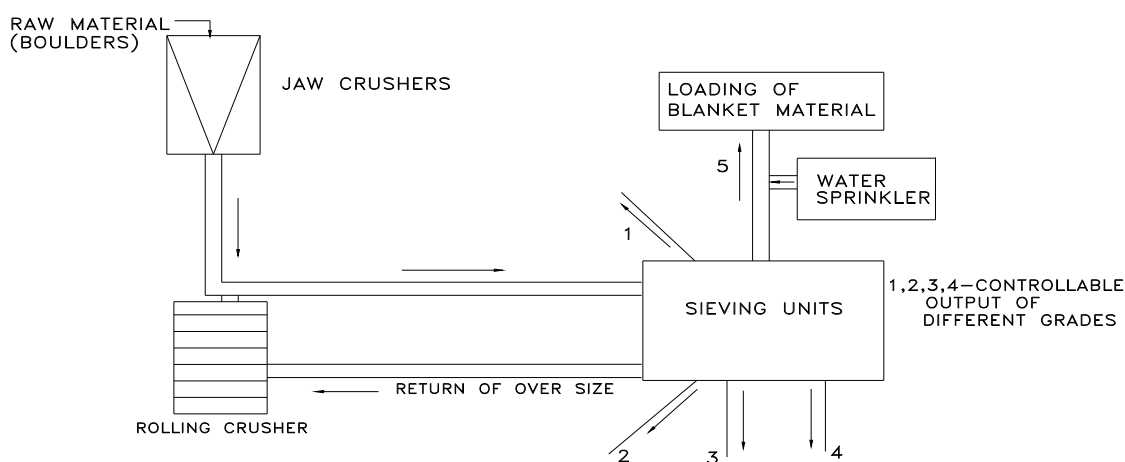

Fig.2 SCHEMATIC DIAGRAM OF MANUFACTURE OF BLANKET MATERIAL BY CRUSHERS

### 1.1 Case study :

Site visit was carried out in the month of May 2005 at Chandigarh to inspect crushing methodology for production of blanket material. Details collected are as follows:

- i) Name of crusher owner: Hargobind stone crusher
- ii) Address: Burjkotian, Chandimandir, Panchkula, Chandigarh
- iii) Make of crusher: Gurudev, Lalkuwan, Delhi
- iv) Source of stone: River Ghaggar
- v) Plant capacity: 830 cft/hour (Approximately)
- vi) Approximate cost: 22 lakh
- vii) Number of persons for operating the plant: 10 labourers, 1 foreman, 2 helpers
- viii) Storage capacity : 4000 cubic feet
- ix) Power: 5 HP to 7HP
- x) Alternative power supply : Can be operated by 320 KVA Generator
- xi) Number of bins: Three
- xii) Number of sieve combination: Three of 20 mm, 10 mm & 6 mm sizes
- xiii) Tank ( For water): For wet mixing facilities

The schematic diagram of for production of blanket at this crusher is given below:

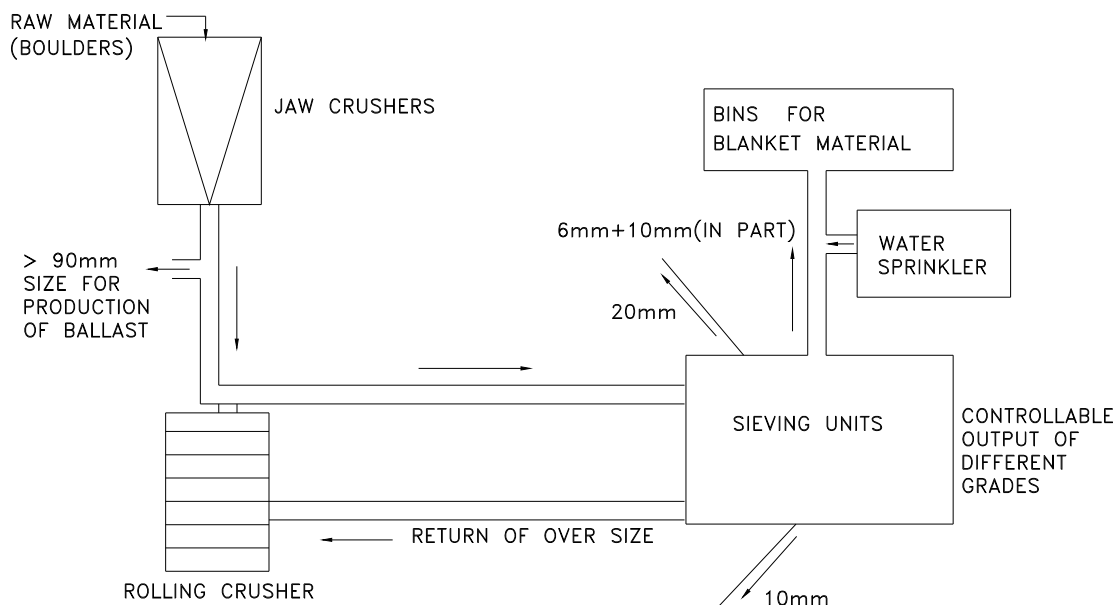

SCHMATIC DIAGRAM OF MANUFACTURE OF BLANKET MATERIAL BY CRUSHERS

Some of the photographs of crusher site are as below:



**GENERAL VIEW OF CRUSHER**

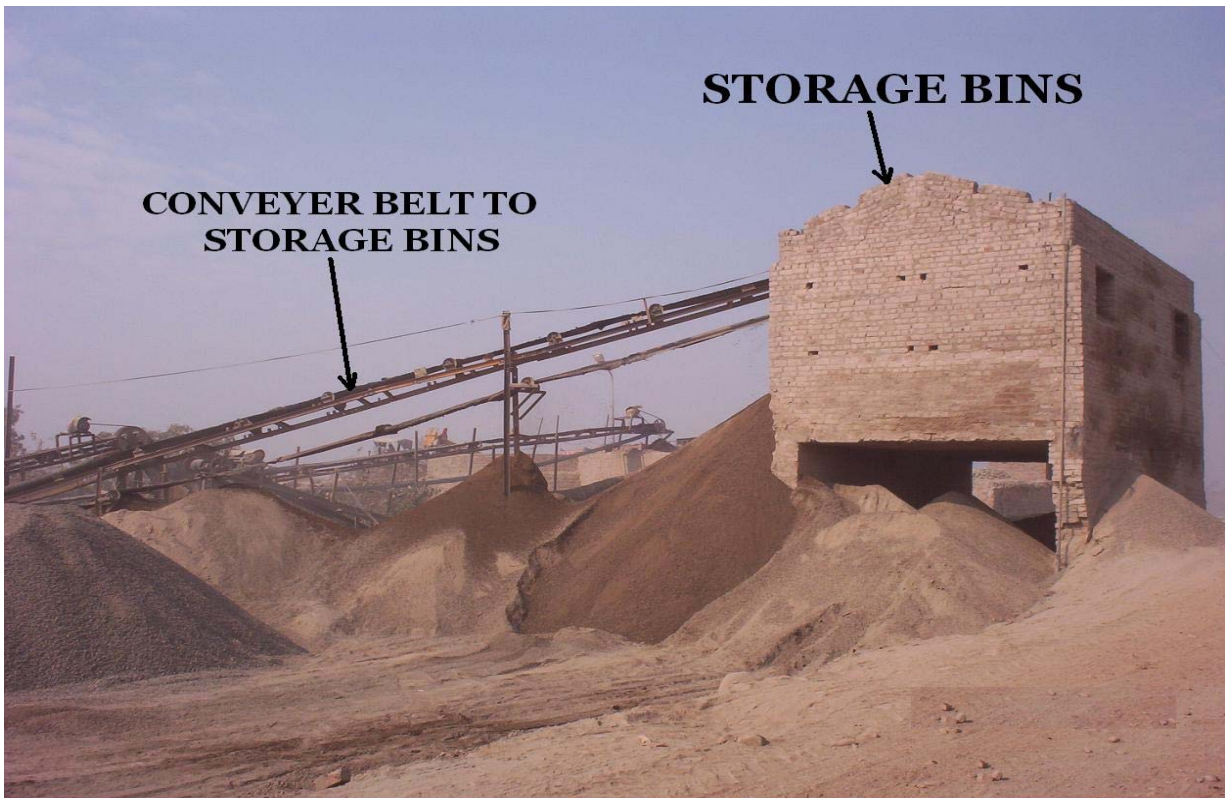

**VIEW OF STORAGE BIN**

## 2 Blending Methodology :

**2.1** Blanket material could be obtained by proper blending of two or more soils or in combination with soils and crushed material like stone chips or quarry dust.

**2.2** Before approving such sources, trials for blending to judge the final product, needs to be done. Detail methodology of blending to be adopted to produce large quantity of blanket material with consistent quality, needs also to be laid down in advance.

- Blending of either natural or crushed materials in a pre decided ratio could be adopted.
- Theoretical and laboratory trials are required in order to establish the desirable ratio of the blending materials. This exercise may be done in advance before finalizing the contracts for such a material. The methodology of blending trials is explained below :
  - Identify the usable materials/soils.
  - Take equal weight of the soils for sieve analysis.
  - Write down the weight retained at each sieving stage for all the soils.
  - Apportion a percentage component to each soil and work out a theoretical mix.
  - Draw particle size distribution curve of the mix to find out desirability of gradation.
  - If not successful, make another trial, and so on.
  - Trials and plotting work can also be done using simple computer programs.

**2.3** Mechanical blenders using simple technology are now available in the market. Two types of mechanical blenders are quite common:

- i) **Drum type blenders:** Drum type machines may involve weigh batching or manual feeding of material. They involve more moving parts. Hence, these machines are both manpower and maintenance intensive. They may pose a problem of segregation of material and as such do not afford any cost advantage either in the short or long run. These may be suitable for small quantities and not for large-scale production as required in construction projects.
- ii) **Pug mill type blenders:** For continuous production of mix in large quantities, the best way is to feed the aggregates/ soils of pre decided gradation by way of 3 or 4 bins with conveyor belt. The required output grading can be achieved by adjustment of gate openings of bins. The use of pug mill type blenders is found very cost effective, as the manpower involvement is very little and only 4-5 people can run a plant of 100 tph. The pug mill blender consists of:
  - 1) Four bin aggregate unit
  - 2) Pug mill mixer unit
  - 3) Water tank and metering system
  - 4) Conveyor belts
  - 5) Storage silos (optional)
  - 6) Anti segregation surge hopper
  - 7) Automation and controls



A schematic diagram showing the various arrangements is shown below:

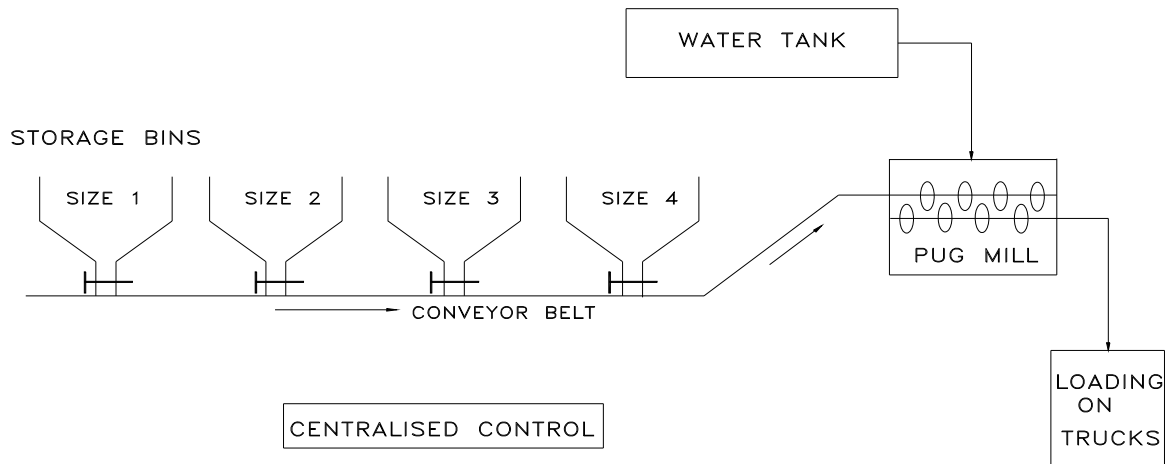

Fig. 3 SCHEMATIC DIAGRAM OF MANUFACTURE OF BLANKET MATERIAL BY BLENDING

The other important features of this technology are:

- Automatic feeding of soils/aggregates under gravity,
- Arrangement for precise control of mixing of water,
- Either direct loading into trucks, or optional storage at plant,
- Availability of domestic manufacturers, and low cost of set up,
- Advantage of removal and relocation with ease.

## 2.4 Case study:

NHAI project site between Sultanpur-Utratia Bye Pass Road, near Lucknow was visited in the month of June 2005 in connection with production of blanket by blending. Details collected are as follows:

(i)	Name of work executing agency:	Atlanta
(ii)	Address:	Amar Saheed Path, Lucknow
(iii)	Makes of blender:	Gujrat Appolo Equipment Ahemdabad
(iv)	Plant capacity:	160 ton per hour
(v)	Approximate cost:	50 lakhs
(vi)	Number of persons for operating the plant:	7
(vii)	Alternative Power supply:	Can be operated by 125 KVA Generator
(viii)	Number of bins:	Four
(ix)	Salient features:	bins, pug mills, wet mix computerized blender

The photograph of the wet mix plant (Pug mill blender) is shown as below:



**COMPUTER CONTROLLED BINS FOR MIXING**



**BLANKET MATERIAL BEING LOADED INTO TRUCK**

- 2.5 The equipment for blending should enable blending of two or more materials uniformly so that the blended material satisfies the specification. The equipment chosen should be cost effective and easy to handle with and efficient. A non-exhaustive list of some of the available mixers/blenders based on market survey & internet search are given below :

<b>S. No.</b>	<b>Trade Name</b>	<b>Make</b>	<b>Mixing Capacity</b>	<b>Address</b>	<b>E-mail Address</b>	<b>Web-Site Address</b>
1	Drum Mix Plant	Speed Crafts Limited	15-120 ton per hour	Speed Crafts Limited, Layak Bhawan, Boring Canal Road Patna, Bihar	exports @ speedcrafttsi ndia.com, info@ speedcrafttsi ndia.com	<i>Not available</i>
2	30 M Supermobile Concrete Batching Plant	Shakti Industrials	12 to 30 m <sup>3</sup> /h	Shakti Industrials 65,Ganga, Off Marve Road Malad (W), Mumbai 400064	shakti_ind@v snl.com	<i>Not available</i>
3	Wet Mix Plant	Gujrat Appolo Equipment	160 ton per hour	Gujrat Appolo Equipment Ahmedabad	sales@the-appolo.com	www.apollo.co.in