

Guitar Amp Mods

By William Terry Newton, Copyright 1990-2022
Document created 12/23/07, last changed 3/12/22

This information is distributed under the terms of the non-commercial Creative Commons license which can be found at the following link: <http://creativecommons.org/licenses/by-nc/3.0/us/>
All trademarked names appearing in this document are the property of their respective companies and may not be used for commercial purpose. Portions of the schematics depicting the original amplifier circuitry, panel designs and other pre-existing characteristics should be presumed the intellectual property of the amplifier's maker unless otherwise verified.

Warning! Tube amplifiers contain potentially lethal voltages! DO NOT attempt to perform work on an amplifier unless qualified to do so and experienced in high voltage safety procedures. This information is intended for experienced technicians and is presented as-is and with no guarantees.

Overdrive Mod Theory

First of all, the tone produced by a properly-tuned stock 50 watt Marshall into a 4/12 cabinet is tough to beat for rock lead, the tone produced by an old Tweed Bassman or Twin is probably the best thing ever for blues, and a blackface Fender almost-anything Reverb is very nice for general-purpose clean. Don't get rid of your stock amps, and when modifying an amp, at least attempt to preserve its stock abilities if it already does cool stuff. The primary reason for doing an overdrive mod is to provide something at least resembling the "cranked up" sound but at lower volume levels that doesn't run everyone out of the room screaming in pain. As the volume goes down, the amount of gain that can be added goes up, producing the scooped-out "Seattle Grunge" tone so popular today. The additional headroom permits using post-clip effects without distorting the reverb and delay products into mush, and permits much better control of the overdrive harmonics, both with knobs and your palm.

Most of these mods follow a few principles which in my opinion results in better preamp distortion. Tones are placed after the clip stage, effects loop after that. Lows are rolled off going into the overdrive to balance out the pickup voltage differences between high and low notes, so that all are clipped equally, usually in a way that rolls off more and more lows as the gain is increased. Typical tone networks tend to boost up the lows so when placed post-clip they tend to restore bass response lost by pre-clip rolloff. Tones also tend to boost the highs so to avoid amplifying the clipping "buzz" the post-clip highs are rolled off so the response is roughly flat from the clip at normal treble settings. To make up for the post-clip high rolloff the highs are often boosted prior to clip so that the treble still acts like a treble. Often (but not always) the gain control contains parts on it so more highs are boosted at lower gains, and the high-boost is limited in effect, too much will make it "glassy" sounding, or worse ultrasonic frequencies will distort the audible note causing "hash", to avoid this gain is rolled off at very high frequencies. At lower volumes our ears hear differently and more bass and less mids are needed to sound balanced. As playing volume is increased the mids need to come up and the bass reduced to remain balanced. Less gain is needed in the overdrive preamp so more lows can be allowed to pass, eventually turning into roughly the proportions found in a stock amp. If done just right, when set to fairly high distortion levels the guitar can be turned down and it'll "clean up" nicely. Usually anyway... this effect is also highly dependent on the guitar.

The following frequency response diagrams (crudely) show what is going on in the various stages of an overdrive preamp that follows these principles. A medium-volume application is shown.

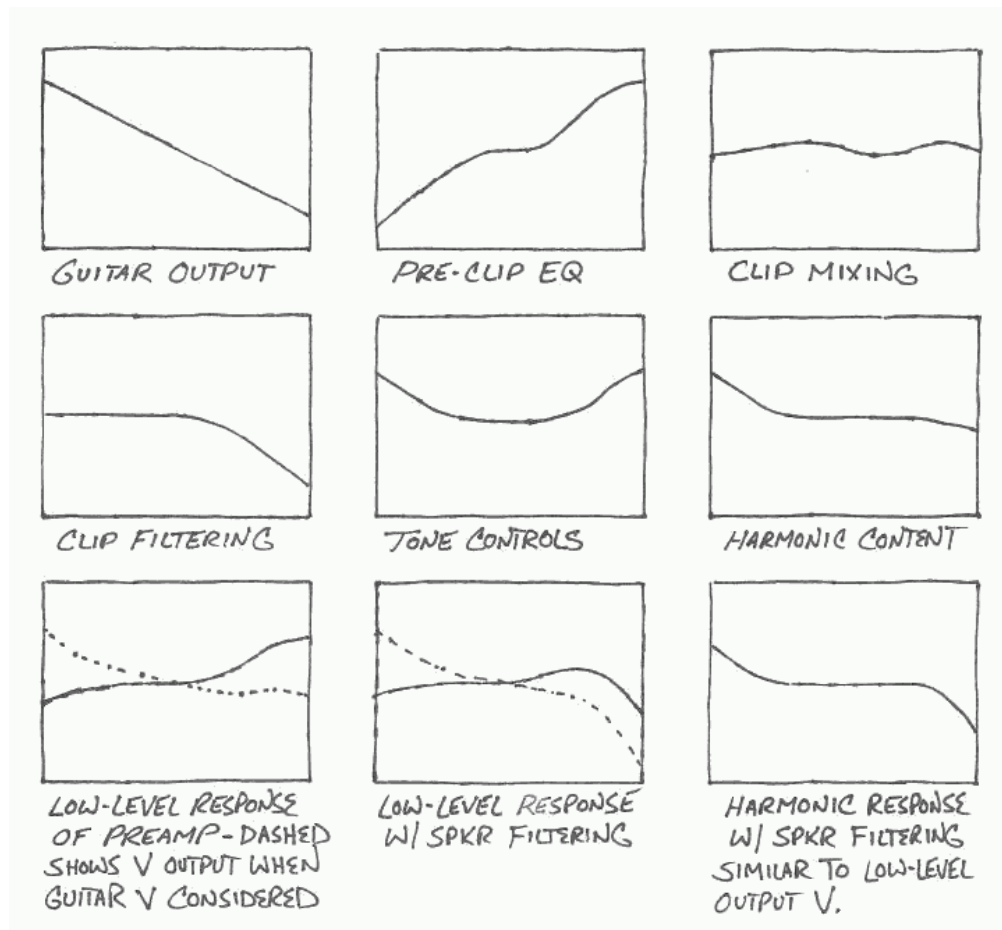

In these charts "harmonic content" isn't exactly a precise term but is used to indicate the frequency response of circuitry after the clipping stage, roughly approximating the signal that will ultimately be applied to the speaker. The important things to note are the bass boost of the tones tends to make up for the low cut that has to be applied to clip different frequencies at roughly the same amount, and that when the voltage output of the guitar is considered, the spectrum is similar at low input levels (when the guitar volume is backed off, or just playing lightly) and under heavy overdrive conditions.

Wiring Considerations

Amps should not hiss, hum or otherwise make racket it's not supposed to. Every gain stage added to an amp multiplies its tendency to amplify noise so proper component selection and wiring is very critical in the first stage of an overdrive mod, and fairly critical in the second stage. High-impedance wiring in the first couple of stages should be shielded, and also wiring which can transmit unwanted signals into other stages such as the distorted output leading to the overdrive volume control. To avoid hum pickup, the cathode wiring should be parallel to the grid wiring, all the way to the signal source. The first stage cathode R/C should be grounded at the input jack, the gain stage cathode R/C should be grounded at the gain control. The best way to ensure that the stage grounds remain parallel to inputs is to ground them through the shields all the way to the signal source.

Component Considerations

There is no such thing as a low-noise resistor, ALL resistance makes "thermal noise" according to their value and temperature above absolute zero. This is the sound electrons make as they bounce off of atoms, even if no current is flowing, the higher the ohms, the more noise voltage is produced. I'm amazed at how many high-gain amps still employ a 68K resistor in series with the first stage grid, according to my calculations at 40 degrees C over a typical 6Khz speaker bandwidth that's about 2.66uV of noise. A couple of microvolts doesn't sound like much, and isn't if the preamp has a voltage gain of only a few hundred times like a clean Fender. Each additional stage can add as much as a 100x more gain, soon that couple of microvolts becomes several hundred millivolts and it doesn't go away when the guitar is turned down. Use something closer to a 1K input grid resistor and it does. At high gain you can hear the thermal noise produced by the guitar volume control, which for a 250K control is 125K/2 or 67.5K max, can't do much about that but at least make it so the noise goes away when you turn it down. The second stage grid resistor is less critical (less gain afterwards) but determines how much hiss the amp will have when set with less gain. Usually values up to 100K or even more are quiet enough for the second stage grid. Resistor noise doesn't factor in much in stages after that.

The first and second stage tube(s) should be selected for low hum and microphonics. Tube noise often depends on the grid impedance so if low-as-possible resistances are chosen for low hiss it will also tend to reduce microphonics. Preamp tube stages should be biased by their cathode resistors so the plate voltages rest at roughly 1/2 to 5/8 of the supply voltage. For a 12AX7 generally a 1.2K to 1.5K cathode resistor is ok for a 100K plate resistor, 2.2K to 2.7K works for a 220K plate resistor, 3.3K for a 330K etc. Increasing the plate resistor increases the gain to a point, for best results the load from the following stages shouldn't be lower than the size of the plate resistor (at least for clean tones), best to not make the first stage plate resistor too high if it's also used for a clean channel. Balancing (or intentionally unbalancing) of the clip symmetry plays a fairly significant role in the type of distortion that's produced and how well it cleans up. Sometimes a trimmer on the clip stage cathode is nice.

The components around the gain control and between the gain and clip stages determine the pre-clip EQ and play a huge role in how good the distortion sounds. Ideally separate controls would be provided to permit fine-tuning but there are only so many knob positions and other controls are more important. As a separate control my favorite pre-EQ control is a low cut between the 2nd and 3rd stages, typically a 3M RA control paralleled with a 0.0022uF-ish capacitor so that at max the control shorts the cap. The components around the gain control should be selected so that at low gains it isn't too thin and at high gains the low notes don't overtake the high notes, typically this is done using a 0.0033uF-ish cap going into a 1M gain control with a 220K-ish resistor from the wiper to ground. If it's too dark at low gain settings then add a 220pF-ish cap in series with a 220K-ish resistor from the control hot to the wiper, but many of my mods didn't have those parts (they were already bright enough at lower gains).

The Mods

The following pages document mods I've done and also theoretical designs which were not exactly implemented (that I recall) but nevertheless express significant ideas. Many tone-affecting details were not documented such as the guitar and speakers being used and the volume level for which the design was optimized to sound best at. Layout details have been preserved only for the mods I was able to take pictures of. These things change the overall response and while for the most part the designs should be fairly close (to my ears anyway) they may need tweaks. Relays usually had 12V 43ma coils and the associated resistor values were chosen for proper operation, adjust accordingly for proper coil voltage.

5/10/90 - Fender VibroChamp Overdrive/Switching Mod

VIBROCHAMP MOD/REBUILD
 DESIGNED BY TERRY NEWTON
 5-10-90

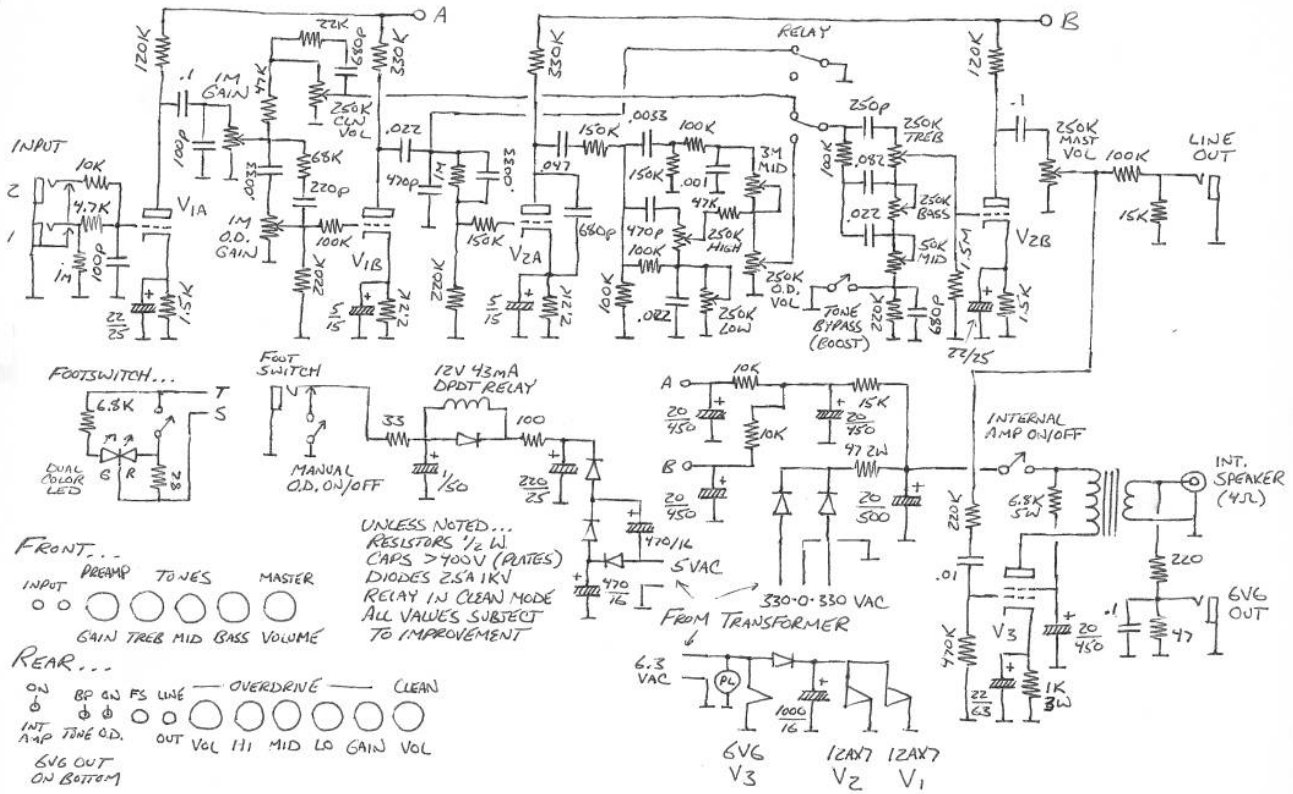

This amp was used mainly as a preamp in front of multi-effects and a power amp, the internal 6V6 could be switched in for low-volume stand-alone use. To keep the front panel clean and make it easier to use an overall preamp gain was used, with individual clean volume and overdrive gain/tone/volume on the rear panel. For using in front of another amp with traditional tones, a tone bypass switch was included, which also boosts the level so to avoid unwanted clipping the clean/OD volumes had to be reduced. The clip stage and tone pickup stage are in the same tube so when the OD volume was all the way down some of the clipping highs were still present in the signal, to avoid this effect the OD volume should be at a normal setting to match the clean volume and the master volume used to set the final output level without affecting the frequency response.

5/25/90 - Fender Bassman Overdrive/Switching/Loop Mod

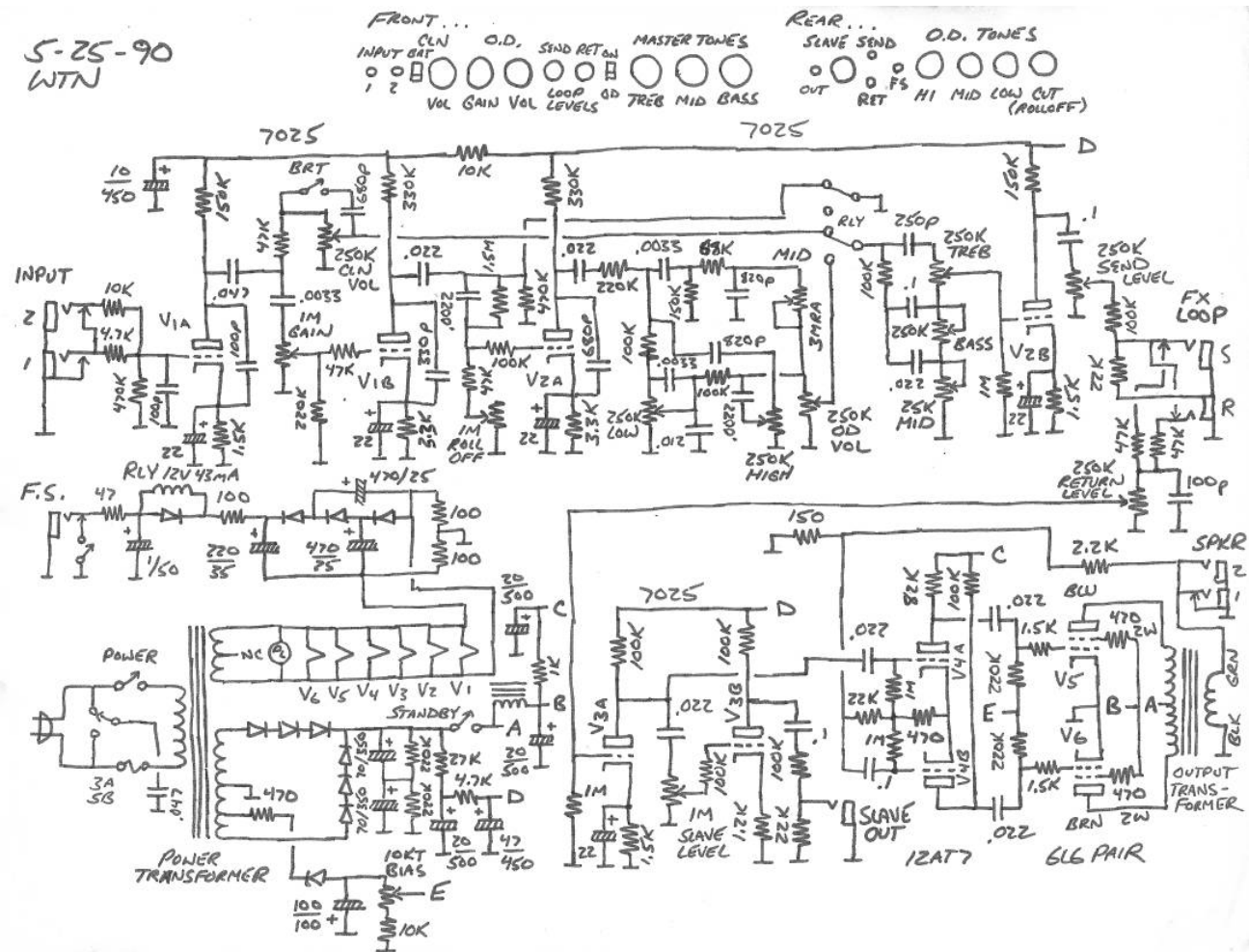

This is a full schematic of a Fender Bassman amp modified to provide foot-switchable overdrive and clean settings, an effects loop with adjustable send and return levels, and a slave output. The clean path mostly preserves the original tone, the volume control is placed before the tone controls, which are shared with the overdrive path, but this seems to have minimal impact. In the stock setup the tones are driven by a constant source impedance of about 60K or so, with the volume before the tones it is roughly that at normal settings but (in the configuration shown) can vary from zero to roughly 180K. The overdrive path is a typical 3-stage setup roughly similar to the Marshall gain/volume design but with more gain and more attenuation of clipping harmonics. The gain control provides compensation for lows but not highs, a control between the second and third stage permits fine-tuning the pre-clip frequency balance. The effects jacks are wired so that if just the return jack is used it mixes with the preamp signal and only breaks the signal if both jacks are used, a more reliable configuration than the usual method of the return jack breaking the signal when used (or if the jack gets dirty). The power supply is wired so the preamp and slave out remain powered when on standby. Later on, this design was modified somewhat, see the 8/7/91 mod. Personally I'd rather use a .001uF cap at the input of the phase inverter and .1uF caps coupling to the power tubes but whatever. Coupling between V2a and V2b will cause high frequencies from the clip stage to bleed through when the overdrive volume is all the way down but with separate effects send and return levels on the front that's not a problem.

10/2/90 - 2-Input Gain/Volume Marshall Gain Mod

JCM800 MOD 10-2+90 BY WTN
(THE ONE WITH HI/LO INS, GAIN, MASTER, TREB, MID, BASS, PRES)
(VOLUME)

REMOVE WIRING FROM HI-GAIN IN TO $68\text{K} + 68\text{K}$ TO GRID (SHIELDED)
(RIGHT SIDE OF 1ST TUBE)

ADD 4.7K FROM HI-IN TO 220pF TO GROUND. RUN SHIELDED WIRE
FROM JUNCTION (SHIELD TO GROUND) TO GRID. ~~XXXXXXXXXX~~

SOLDER 2.2K RESISTOR AND $22\mu\text{F}$ CAPACITOR (+ TO TUBE CATHODE)
ACROSS 10K RESISTOR

SOLDER 100pF CAP ACROSS 1ST 100K RESISTOR, 330pF CAP ACROSS
2ND 100K RESISTOR AND 330pF CAP ACROSS 100K RESISTOR
OVER 2ND TUBE SOCKET

REMOVE $470\text{K}/470\text{pF}$ NETWORK FROM LO-GAIN INPUT TO VOLUME
POT. REPLACE WITH $.0047\mu\text{F}$ CAP.

REMOVE CAP ON VOLUME CONTROL. ADD 330K FROM WIPER
TO GROUND. (TAKES OUT EXCESSIVE LOWS AT HIGH GAIN)

TRACE WIRE FROM WIPER OF VOLUME TO GRID OF 1ST TUBE (B)
UNWELD & REMOVE FROM UNDER BOARD. SOLDER 100K
RESISTOR TO GRID. ROUTE WIRE OVER BOARD & SHORTEN
& SOLDER TO 100K RESISTOR. (ON LEFT SIDE OF 1ST TUBE)

REMOVE GRID WIRE FROM 2ND TUBE, SOLDER 100K RESISTOR
TO GRID & SOLDER GRID WIRE TO 100K RESISTOR. (LEFT OF 2ND TUBE)

FOR ADDITIONAL LOW END ON OUTPUT, BRIDGE $.1\mu\text{F}$ 400V
CAPS (Z) ACROSS EXISTING $.022\mu\text{F}$ CAPS FROM 82K & 100K RESISTORS
TO CORRESPONDING 150K RESISTORS IN DRIVER STAGE.

NEW SCHEMATIC...

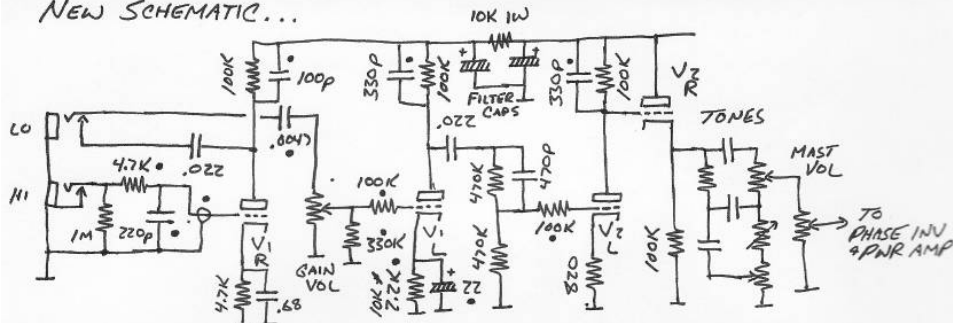

• = ADDED OR ALTERED CIRCUITRY

THIS MOD INCREASES OVERDRIVE GAIN & STABILITY AND
SMOOTHS OUT HI-END (TAKES THE 'GLASS' OUT). LOTS OF
HARMONIC-TYPE FEEDBACK WITHOUT PICKUP WHISTLES.

This is a generalization of the kind of mods I was doing to JCM-800 gain/volume Marshall amps to increase the gain and smooth out the tone, the stock circuit was already the "correct" topology just needed to be opened up and toned down. Not sure I agree with the 4.7K cathode resistor on the 1st stage but with the $.68\mu\text{F}$ cap would give quite a mid boost and apparently was the stock value. The schematic doesn't show it but the jack side of the $.022\mu\text{F}$ capacitor from the 1st stage connects to a ground side switch on the high-gain input to avoid pops when plugging into the low-gain input.

12/06/90 - Fender Bandmaster Overdrive/Switching/Loop Mod

BANDMASTER MOD 12-6-90 WTN

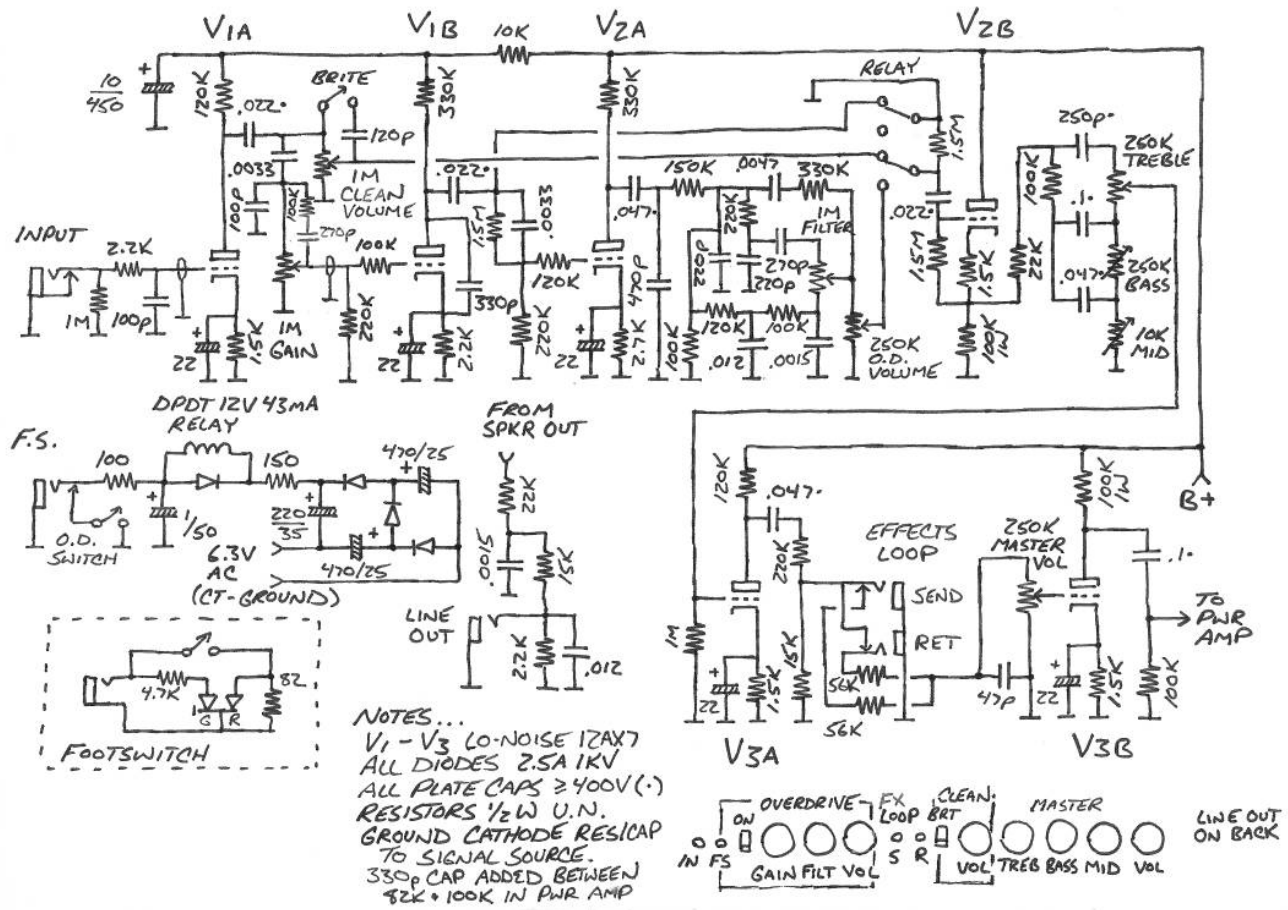

This mod keeps the amp chassis stock except for the line out jack and doesn't have to have that. V2B is used as a unity-gain buffer for the tones, not strictly necessary (could just run the output of the relay right to the tones) but probably helps make the tone controls work better. At least it avoids the bleed-through issue, when the overdrive volume is down it shorts out any signal picked up by the grid. The vibrato section is removed so its tube and control positions can be used for an added mid control and the master volume. The overdrive and clean volumes set the send level, the master volume sets the return level. The line out jack has high-frequency rolloff to make it sound (sort of) like a speaker.

I don't remember who's amp this was but notes on the schematic indicate it was something that was built for someone - the 100K and 270pF on the gain control appear to be added after the original drawing was made (and the 270pF was white-out corrected), 1-watt resistors used in a couple places (silverface), and the clincher is the note about a 330pF capacitor added to the power amp section.

Marshall Mod Ideas from 1991

Here are a couple of mod designs that weren't built exactly as depicted (that I can recall) but represent some of the ideas I was fooling around with at the time.

OVERDRIVE / EFFECTS LOOP FOR MARSHALL AMPS 2-4-91 WTN

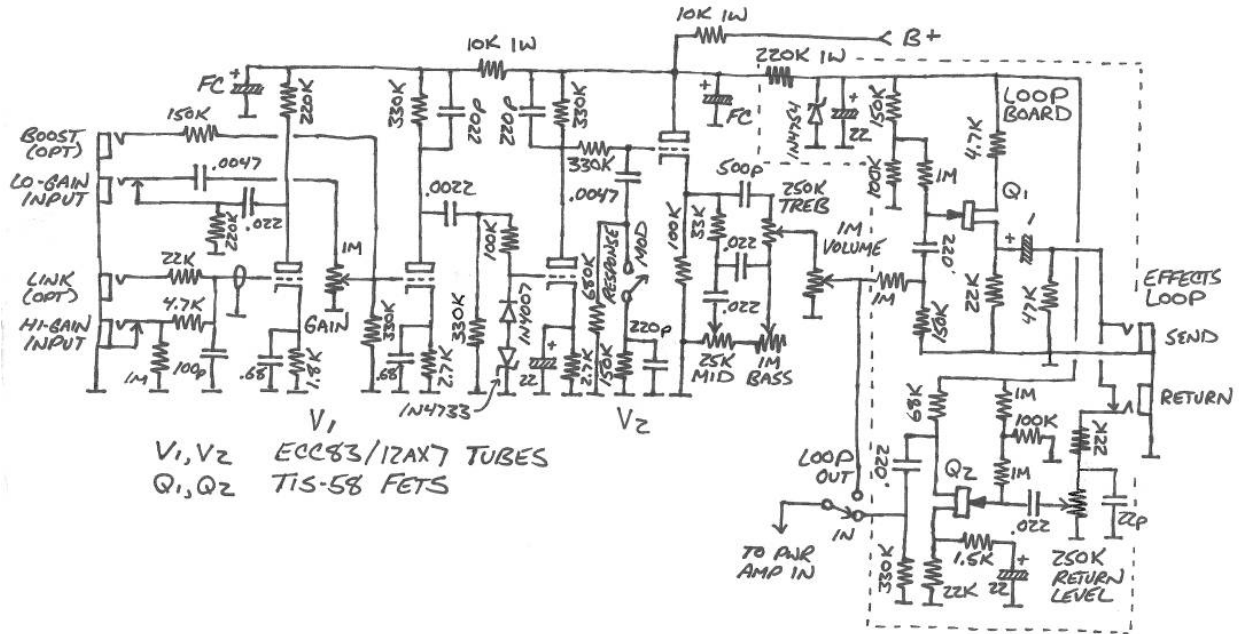

MARSHALL PREAMP / FX LOOP MOD 3-2-91

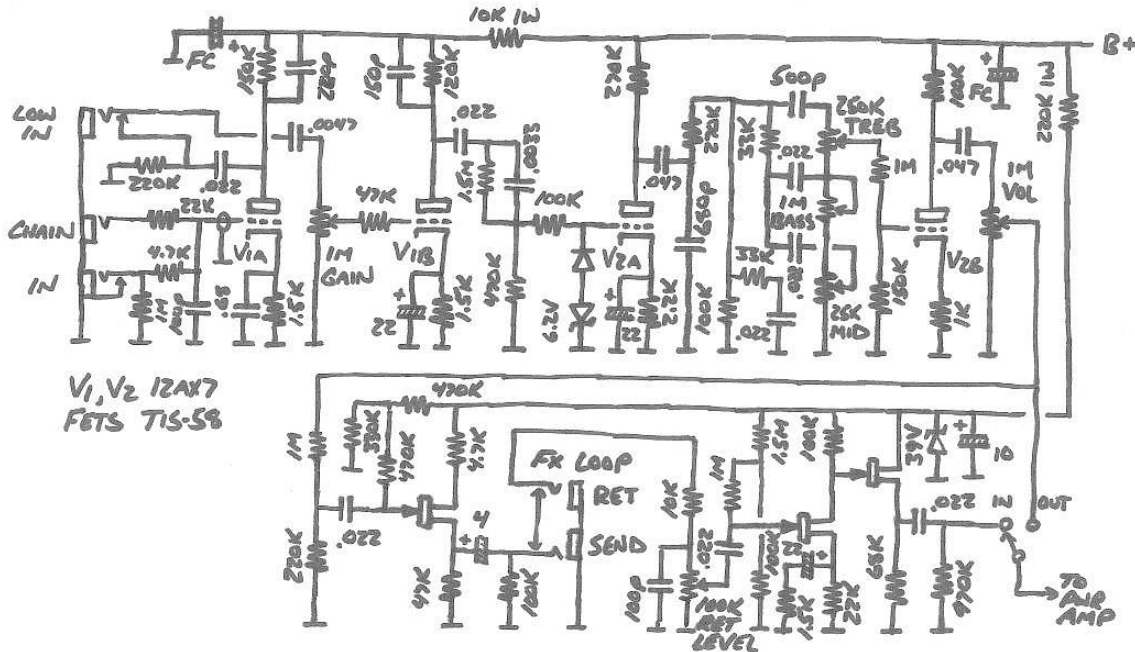

12/25/91 - Fender Champ Reconstruction

SUPER-CHAMP (AS OF 12-25-91)

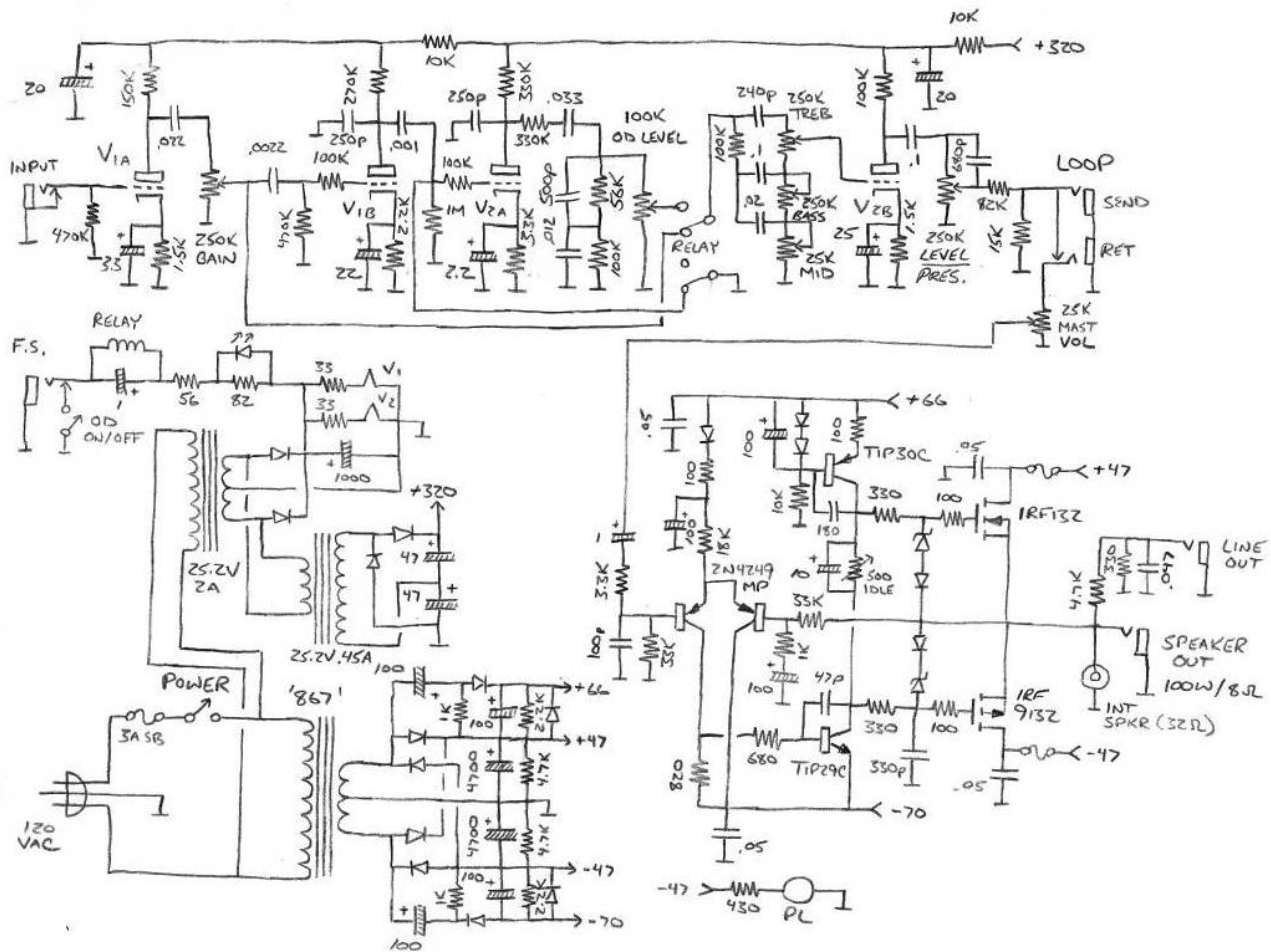

I built this amp for myself, not much remained of the Champ it was made from except for the chassis, preamp tube sockets and some of the controls and jacks. The "super" in the name referred to its power of over 100 watts into 4 ohms, nothing to do with Fender's Super Champ. The preamp had channel switching of sorts but the preamp gain was shared with both the clean and dirty selections so to get maximum overdrive the clean got dirtied up too. The zener diodes protecting the gates of the output mosfets were probably 6.2V or thereabouts but the design didn't have any protection from thermal overload or anything more than a momentary short.

This was my main amp until I put together the "mod gone mad" bandmaster then it served time as my backup and sidefill amp, I'd put it on the corner of the drum riser opposite my main rig so the back provided monitor for the drummer and the front provided monitor for myself and the bass player, using a signal from the other "stereo" output of my delay unit plugged into the power amp in jack. Sadly it died at a strange gig in the old jail in Manchester, TN when the sound dudes blew their monitor amp and I stupidly let them drive the monitor chain with it, smoke came out. Never bothered to fix it and the poor thing got salvaged for parts.

1/25/92 - Fender 135W Twin Reverb Overdrive/Switching/Loop Mod

MASTER TWIN MOD 1-25-92 WTN

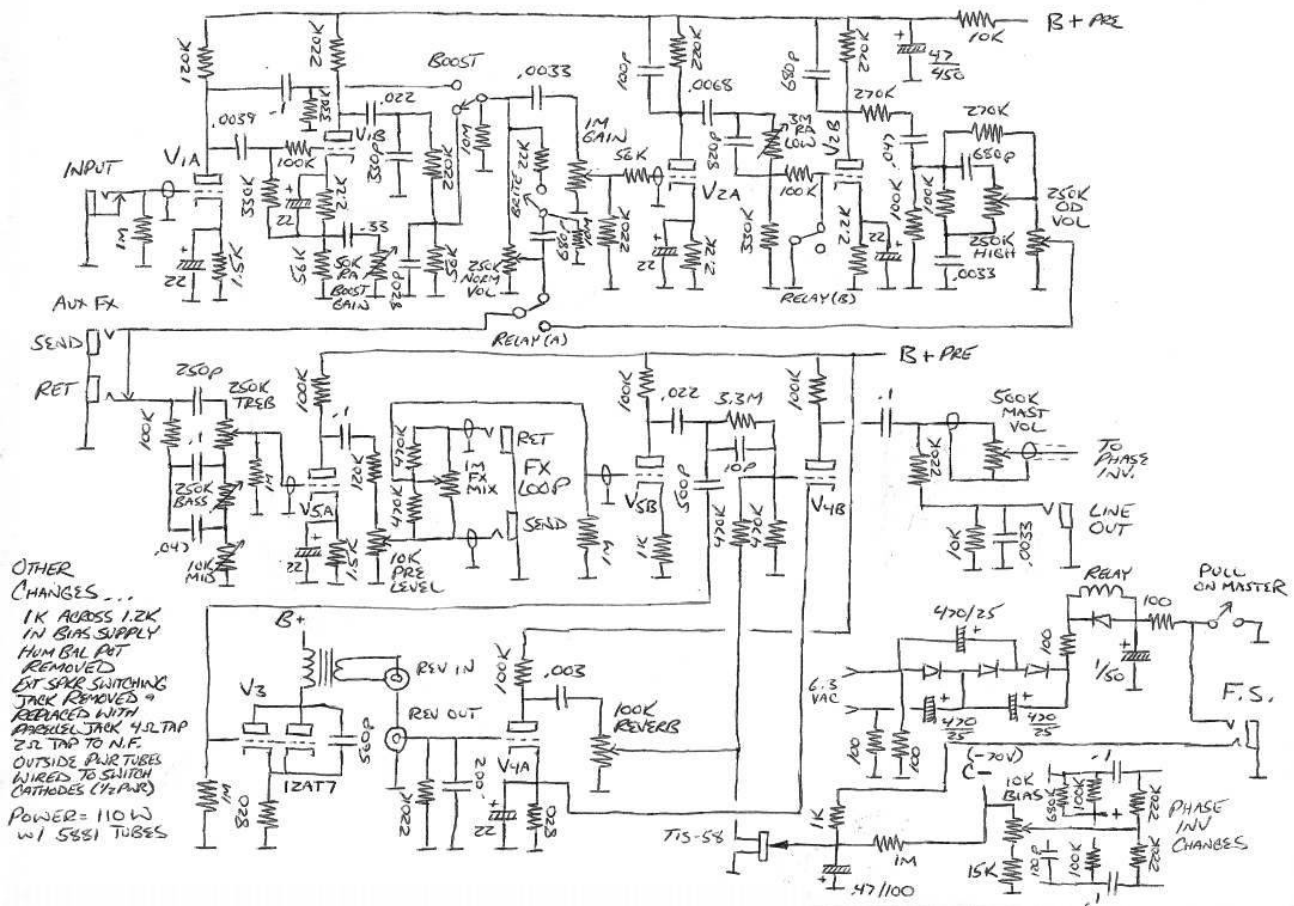

I'm still trying to figure this one out - literally. It may have been a case of doing too much for the application, the customer I made it for eventually favored smaller simpler amps more suited to his needs and this monster ended up in storage where moisture got to the cabinet and speakers. Recently he dragged it back to the shop offering to sell what was left of it, the chassis was still in perfect working condition so I bought it for myself, threw some salvaged Music Man speakers in it and removed the studs from another damaged reissue Twin Reverb baffle board to use for a front grill. I used it a few days ago at a fairly high volume and one one hand it really rocks out, but I might have to do further mods to it - the overdrive preamp has a bit too much low-frequency response, had to run the low-cut control all the way down. I'm thinking the .0033uF feeding the gain needs to be dropped to .0022uF or maybe even .0015uF, and a high-compensation network of say 220K in series with 470pF added to the gain control. Maybe drop the 330K connected to the low-cut control to 220K. At high volumes the mid must come up, had to set in the 7-8 range to make it sound right (right in line with theory, brings the post-clip frequency response closer to flat). At lower volumes insane amounts of gain can be dialed up by kicking in the boost stage. Before monkeying with it too much I need to put better speakers and tubes in it, it's plenty usable just as it sits.

The photos on the next page show the innards of this amp, not exactly art but typical of my "cram it in there" style of modification.

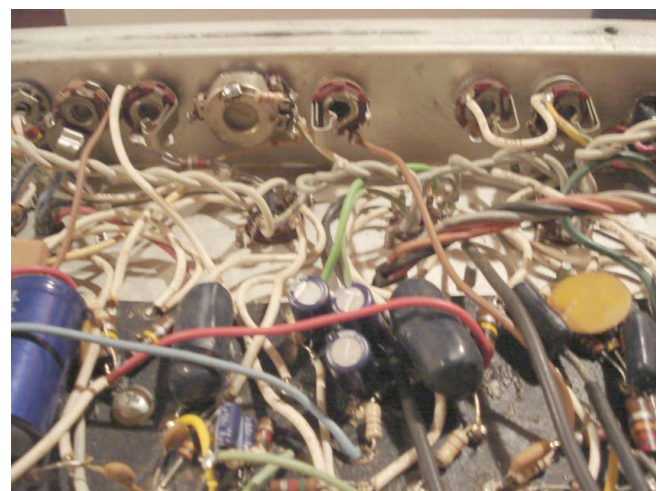
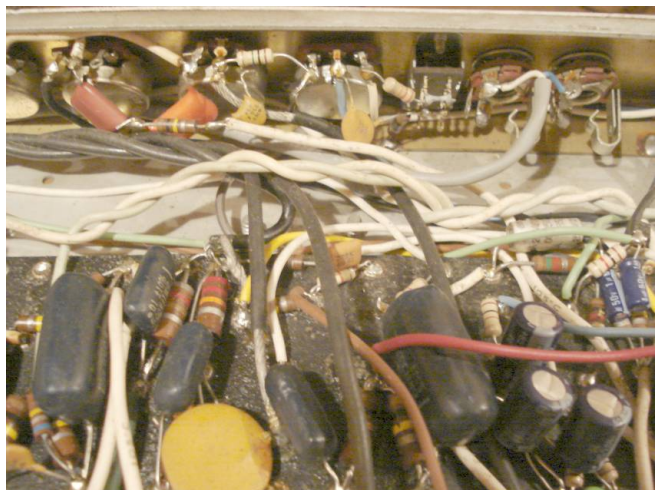
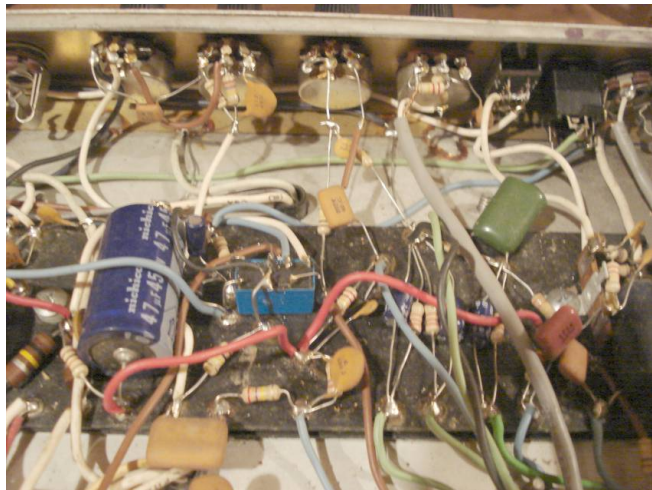
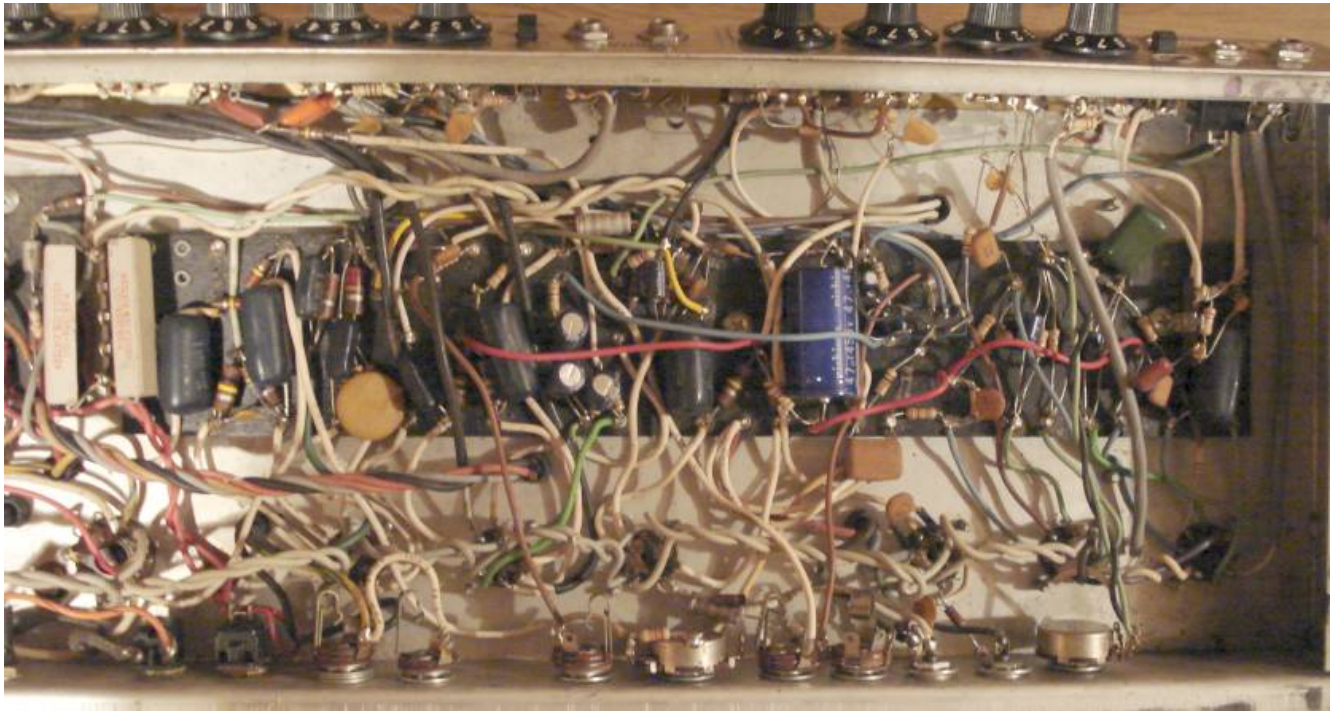

3/16/92 - Fender Bandmaster Reverb Boost/Overdrive/Switching/Loop Mod

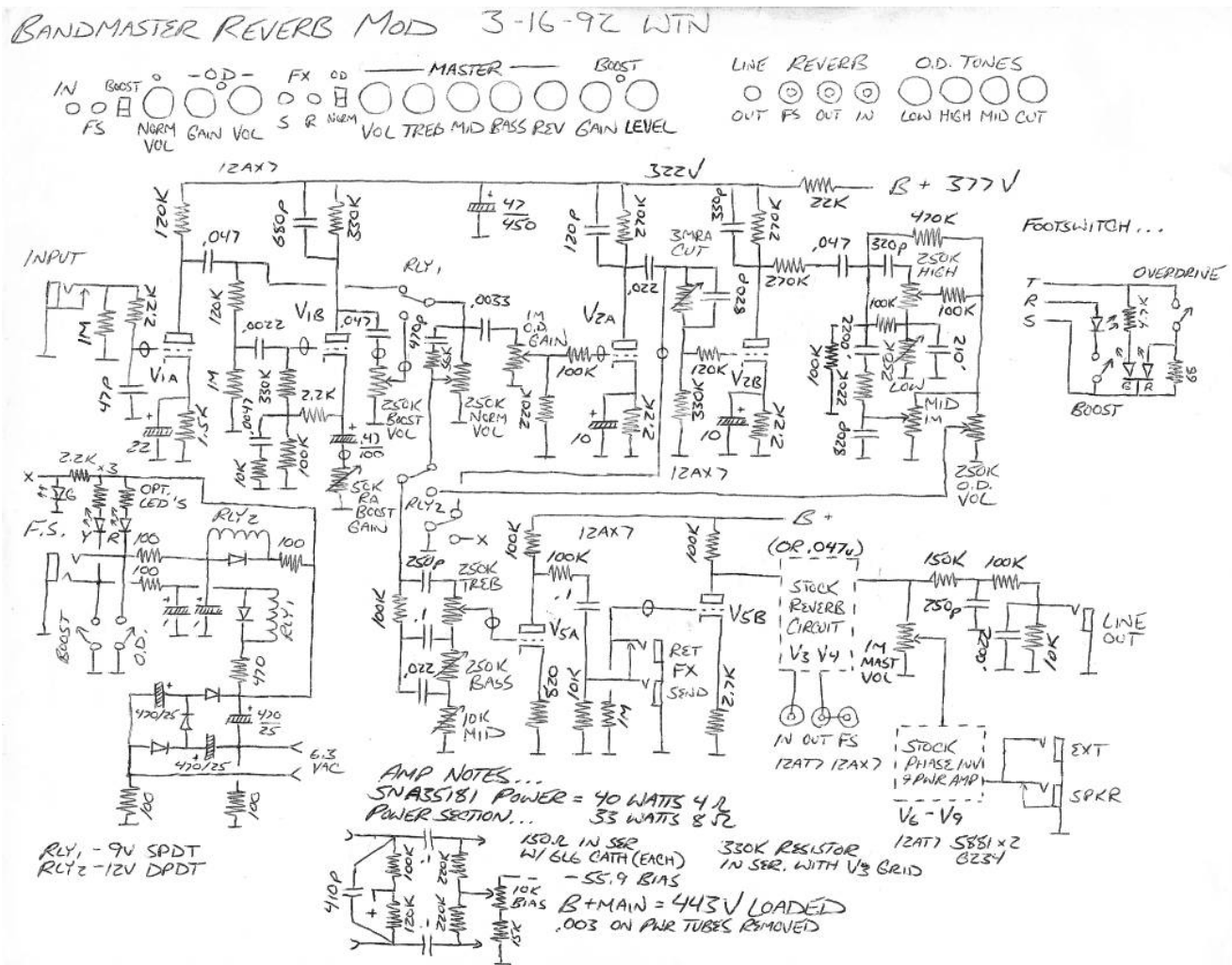

This design provides footswitchable boost and overdrive settings for clean, crunch, regular distortion and extra overdrive. The optional LED's were not fitted, the knobs aren't labeled so from the front it looks like a totally stock silverface Bandmaster Reverb head. The boost gain is arranged so that as the gain is increased, lows are decreased, and at lower gain settings highs are increased. The gain control has low compensation but not for highs, the low-cut control has a fairly high turnover frequency and it doesn't seem to need any more highs. A 330K resistor was placed in series with the 12AT7 reverb driver grids to keep it from distorting the highs at higher preamp levels, later on the 150 ohm resistors in series with the 6L6 cathodes were bypassed for more output power.

This amp came to visit me for our yearly Holiday jam and I took the opportunity to snap a few pictures of its insides, if any changes were needed something would have been said then or the other times it's come in for tubes and cleaning but it sounds fine just like it is. Long ago apparently the transformer blew and coated everything with a layer of brown tar, doesn't seem to hurt anything now but initially I really had to spray out the controls and scrape the jack contacts. Pictures are on the next page.

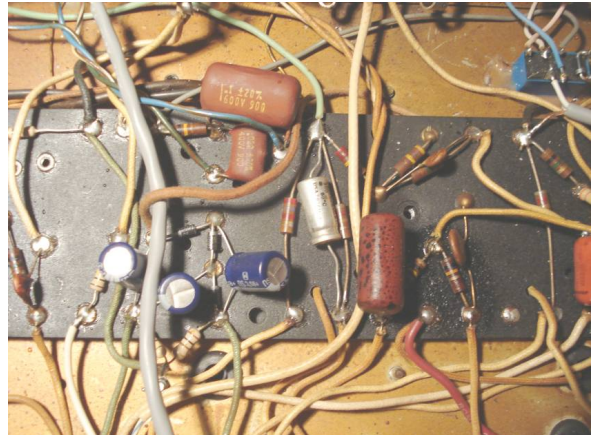
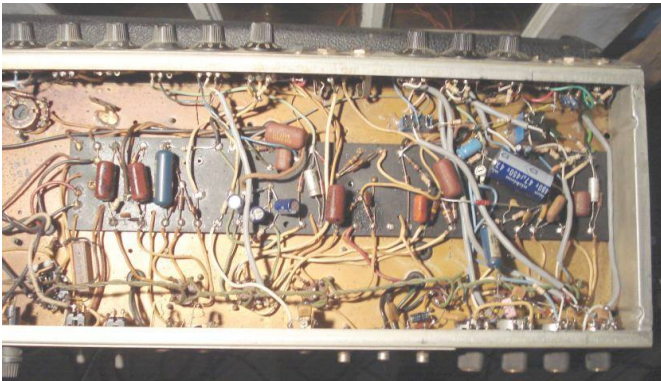

4/6/92 - Fender Princeton Reverb Overdrive/Loop Mod

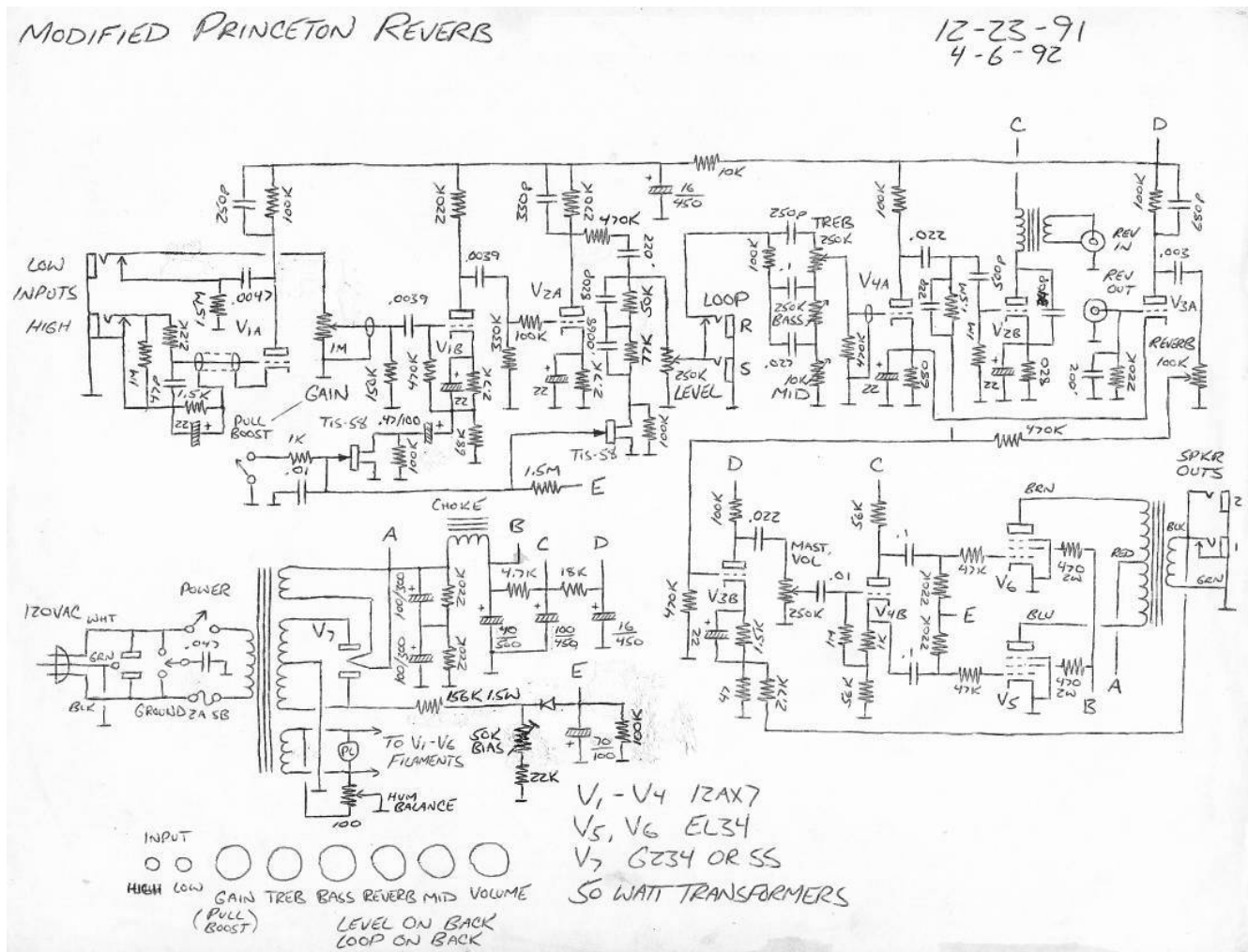

This amp is a little rock-and-roller! The transformers were replaced to add a 50W EL34 output section driven by a single-ended phase inverter, the grid resistors are 47K to avoid too much shifting of the duty cycle when the power tubes are clipped. It doesn't have channel switching (just a switchable gain boost that drops the level and applies post-clip filtering) and doesn't do clean all that well. The reverb works but isn't as strong and sweet as a regular Fender reverb. The customer I originally made it for liked it for rock but blew out the speaker and got a gig that required clean tremolo and sold the amp back to me, all I did to it was put another speaker in it (didn't bother to change the worn out tubes, they still work). Not too long ago I carried it to a club where they needed another amp for Razzie Bailey and other musicians to play through, don't know what he thought of it but I thought he sounded good, at lower gain settings it produces a nice blues tone. The next guitar player found the pull boost and probably dialed up too much overdrive but he seemed like he was having fun.

Note... this schematic is for the original mod, at some point the old tubes finally gave out and I converted it to 6L6 power tubes and did other mods, see next page.

5/12/16 - More about the modified Princeton Reverb

For the past couple of years I've been using this amp at Skully's Saloon where I play at an open jam on Sundays and a blues jam on Tuesdays, most guitar players love it - it's got a smooth yet "hot" overdrive that is very hard to get with other amps, it can be set where it's not really that loud but sits well in the mix and pleases the pickers sitting in... they keep wanting to buy it but it's not for sale. But I can build one, for about \$2500 or so if I do it hand-wired with premo parts. Looking at ways to make cheaper. It's not for everyone though - although it can be set fairly clean, if one wants that sparkly clean Fender sound and use only pedals for overdrive, just get a Fender or one of the many kits or similar recreations, this amp is meant to rock out all by itself. If you need the clean to be clean and the dirty to be independent of the clean setting, then a dual-channel design (with or without independent tones) is better, this amp is a single channel design with gain switching, the dirtier the overdrive then the dirtier the clean will be. But it works well for me (I use my volume on my guitar to set my gain, if I want clean I turn down), and it works well in a jam situation because there's only six knobs on the front and they all work no matter which mode is selected, only takes seconds to dial in a tone.

The only thing I've done to the circuit is add a unity-gain buffer between the master volume and the effects send jack to avoid high-frequency cable loss when using pedals - I've been using a small pedalboard with a tuner, autowah and phase shifter up front and a delay in the loop (along with the amp gain switch), noticed some loss of presence when pushing 20 feet of cable. Don't recall the precise circuit I used at the moment but it's something like...

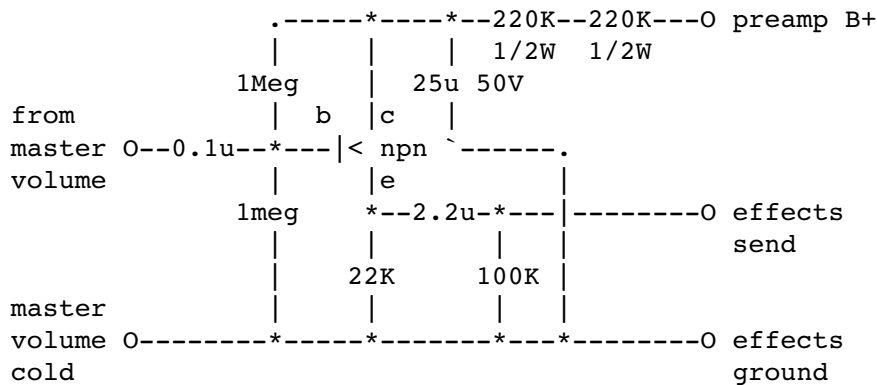

Might have used a zener diode but isn't really needed, with these values the transistor collector and filter cap will get a bit under 1/10 of the B+ supply voltage, or about 24-40 volts with typical preamp supply voltages. At 400 volts supply current drain should be about 0.83ma and total dissipation of the circuit about 1/3 watt. With a 250V supply maximum undistorted RMS output is roughly 6V RMS into a 500K load and about 4.5V RMS into a relatively heavy 50K load, far more than the typical signal level of about 0.5V RMS tops at this point, so the transistor should never clip (if it does the pedal is already creamed anyway). This is maximum output level before clipping, gain remains near-unity for any load over a few K. Just about any small NPN transistor can be used, 2N3904, 2N5089 etc.

I really want to make a production version of this amp... but probably not using a digital reverb module. Adding a simple transistor FX buffer is one thing (still pure analog, not even a chip) but throwing in digital stuff is a whole 'nother can of worms - power supply, EMI concerns - plus most of my customers still like good old fashioned spring reverb and the Princeton-style phase inverter doesn't bother me. So for now sticking with the mostly original plan with MOC-type switching and perhaps a double-sided PCB with top-loaded parts to lower the assembly labor cost.

1/31/93 - Theoretical Fender Overdrive/Switching/Loop Mod

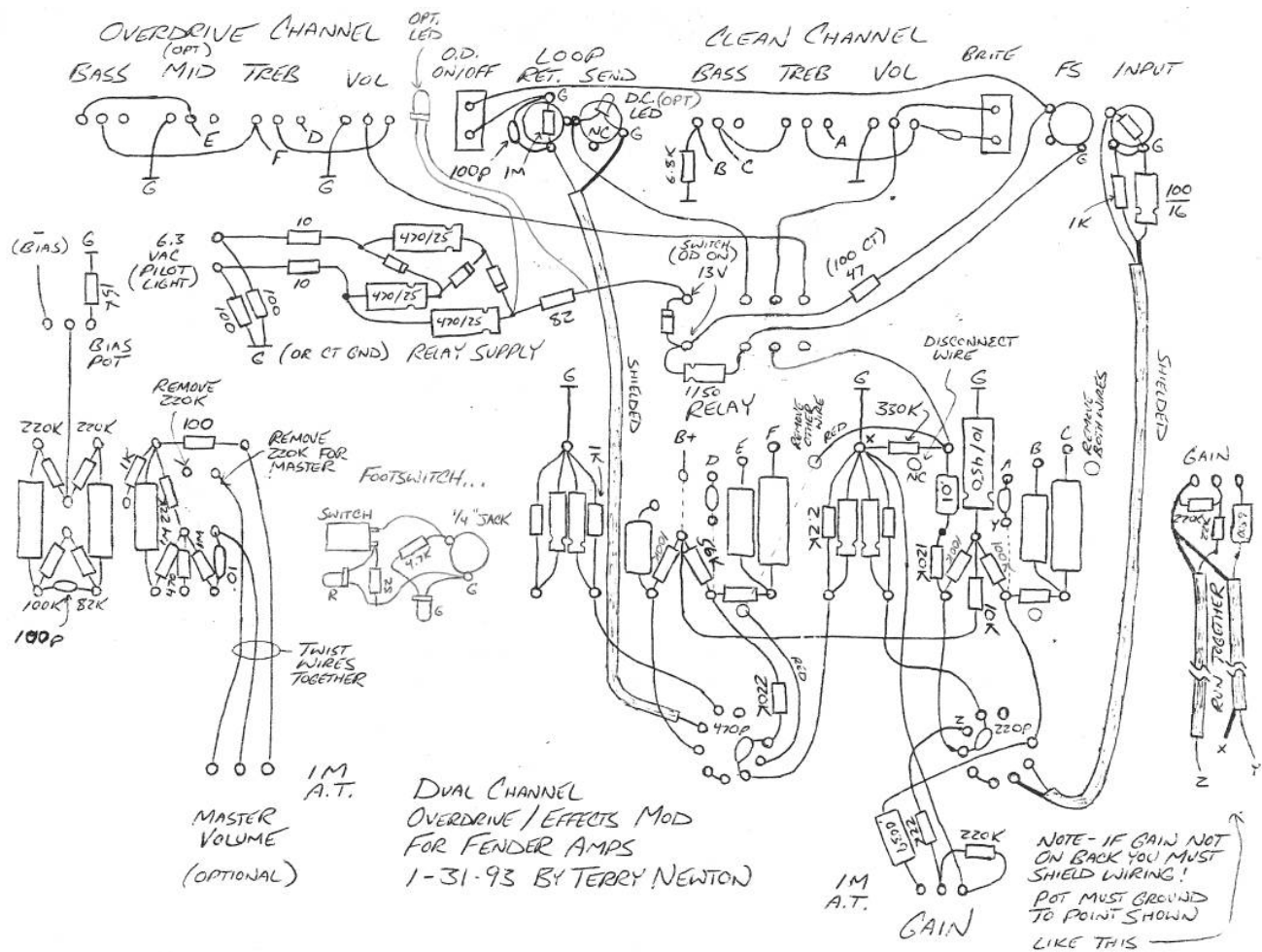

This is a hypothetical hookup diagram for rewiring the first two preamp tubes to provide channel switching and a simple effects loop. The tremolo can remain intact but can be disconnected and used for knob positions for the added gain and master volume controls. The diagram shows a 1 meg control for the master but a 250K control is probably better. The relay (like the other mods) has a 12V 43ma coil, if different adjust the size of the 82 ohm resistor accordingly. If the current is too different the footswitch design needs to be altered. If the power transformer has a grounded center-tapped heater winding the 47 ohm resistor should be increased to 100 ohms to compensate for not having the 100 ohm heater resistors. Unlike the other mods this one provides separate tones for the clean and dirty channels. I haven't actually tried this design that I recall but it is similar to other dual-channel mods I've done, I'm guessing it sounds pretty good or at least is close enough to tweak in with a few component changes, if too much low end going into the overdrive reduce the value of the .0039uF cap feeding the gain control. If more highs are needed at lower gain settings add a resistor and a cap between the gain control's wiper and max terminal, start with something like 470pF in series with 220K. Or perhaps alter the coupling between the second and third stages as done in some of the other mods, in this design it's just a 120K and .01uF in series. If the clipping harmonics are excessive try adding another capacitor in the .001uF range across the 56K resistor, which also sets the relative output of the overdrive channel.

2/16/93 - Radical Fender Bandmaster Boost/Overdrive/Switching/Loop Mod

MODIFIED BANDMASTER
AS OF 2-16-93 BY WTN
S.N. A19305

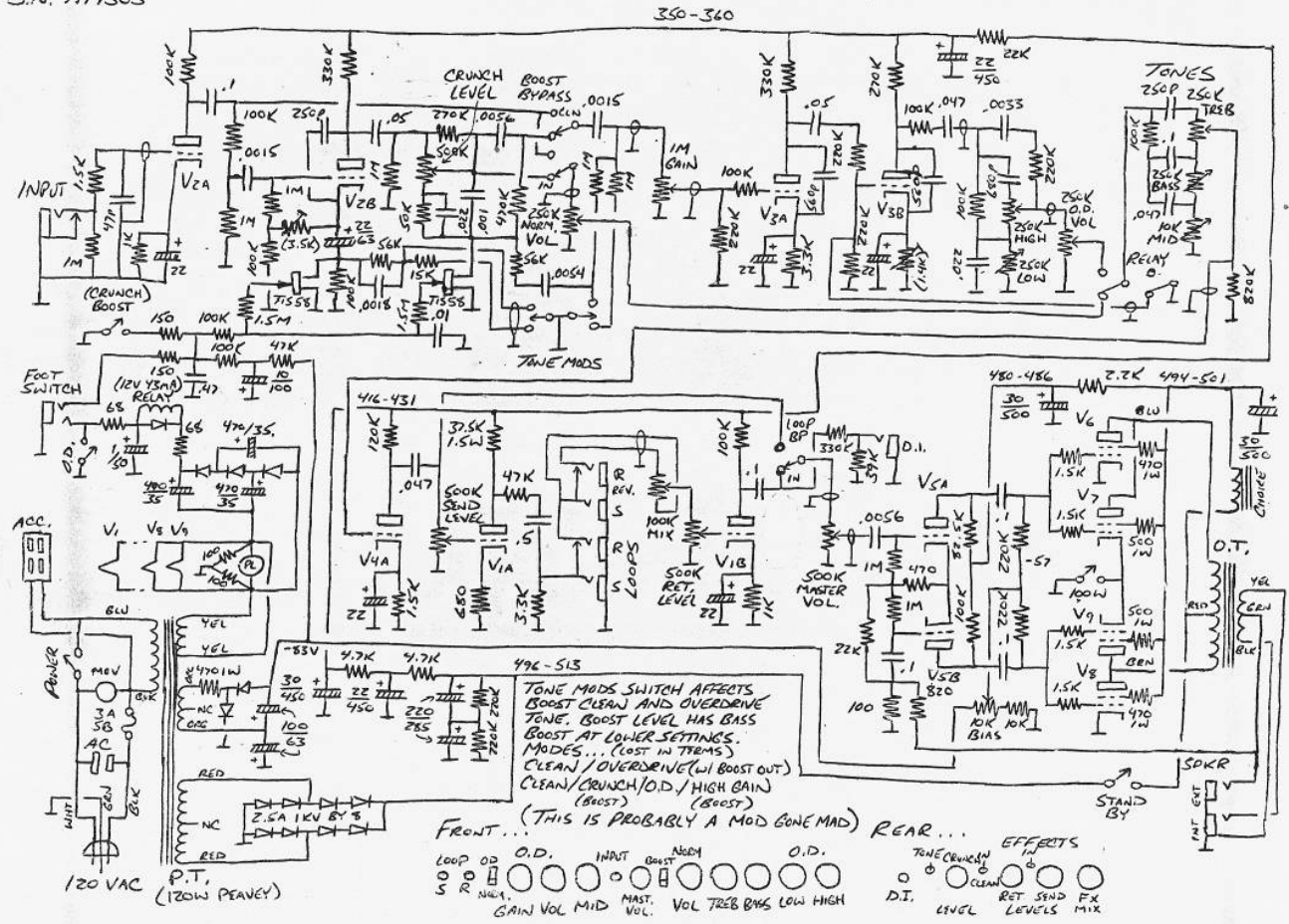

This was a blackface Bandmaster, it had already been modified by someone else with different transformers to increase the power somewhat. It started out as a fairly normal mod typical of the others but the original customer wasn't happy with it, kept wanting more gain. That's different... usually if anything they want to back it off. No matter what I did I could not achieve the desired tone, by then it had so much gain it was practically unusable and the owner put it up for sale, of course I bought it right away. First thing I did was add a switch so all that radicalism could be turned off, returning it mostly to the way it was after mod'ing it the first time around. I used it that way for a spell but found myself having to turn the bass all the way down to keep it tight and still wasn't loud enough so popped the covers off the chassis cutouts and added two more 6L6's, straining the existing power transformer so replaced it with a transformer from a 120 watt Peavey VTM. Now I could turn the bass up but it ran dangerously hot, about the same time I got a Yamaha "REX" effects unit which fit perfectly underneath so added the end from an extension cord for switched "accessory" power and plugged in a fan and an AC adapter, and drilled yet more holes to add additional loop bass jacks and an effects mix knob. This was my main rig for years until I decided to try to make it in Virginia Beach, broke and dejected had to take a bus back to Nashville (where amps were stacking up for me to work on) and had to leave it behind. I was intending on having it shipped back but it kinda got adopted by another musician... that seems to happen a lot with amps. One day maybe it'll find its way back home.

3/2/93 - Fender 75 Overdrive Mod

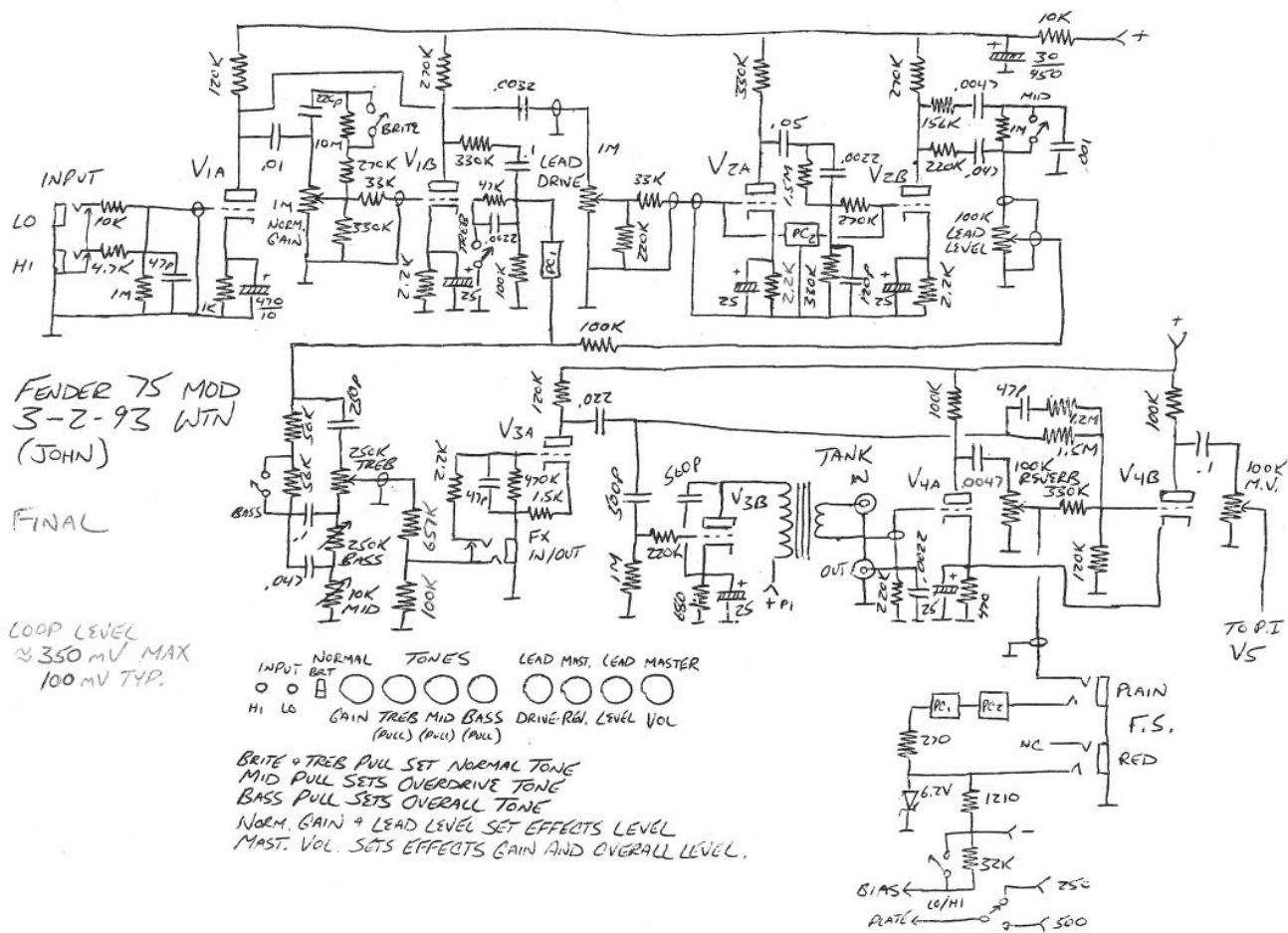

Back in the '80's Fender produced a couple of historically significant amps with overdrive, the Concert and the 75. Both were typical of distorted amps back then, tones were placed pre-clip and pretty much only sounded right if cranked. The Concert had independent clean and dirty channels and is fairly easy to mod for higher-gain lower-volume ability, not much more than moving the tones after the clip stage and putting a capacitor across the gain control so it'd function as a pre-clip EQ, the switching and loop circuits don't have to be changed. The 75 is another story, it shared the same tones and signal path with both the clean and dirty settings, pretty much the preamp section has to be ripped out and replaced.

This rendition provides a normal channel that can be set on the dirty side by cranking the normal volume and pulling the treble switch (or pushing it, can't recall, in any event by closing the switch) to drop the level and apply a bit of filtering. The dirty channel is a fairly standard-issue 3-stage design with fixed pre-clip high EQ and a low-compensated gain control, the mid pull controlled the post-clip filtering. Rather than select the paths directly the overdrive output was connected all the time, when all the photocells energized it connected the normal path's output and a dual photocell disabled the overdrive gain stages. A dual cell was used to avoid having to have 3 LED's in series, not enough voltage in the switching circuit for that. The bass pull was wired to change the tone control network and shift the overall response. The effects send had no buffering, driven directly from the tones, from there it was pretty much a normal effects return and reverb circuit with a master volume before the phase inverter. Worked out well, used it a few times for rehearsal and it had what I liked.

5/5/93 - 4-Input Marshall Overdrive/Loop Mod

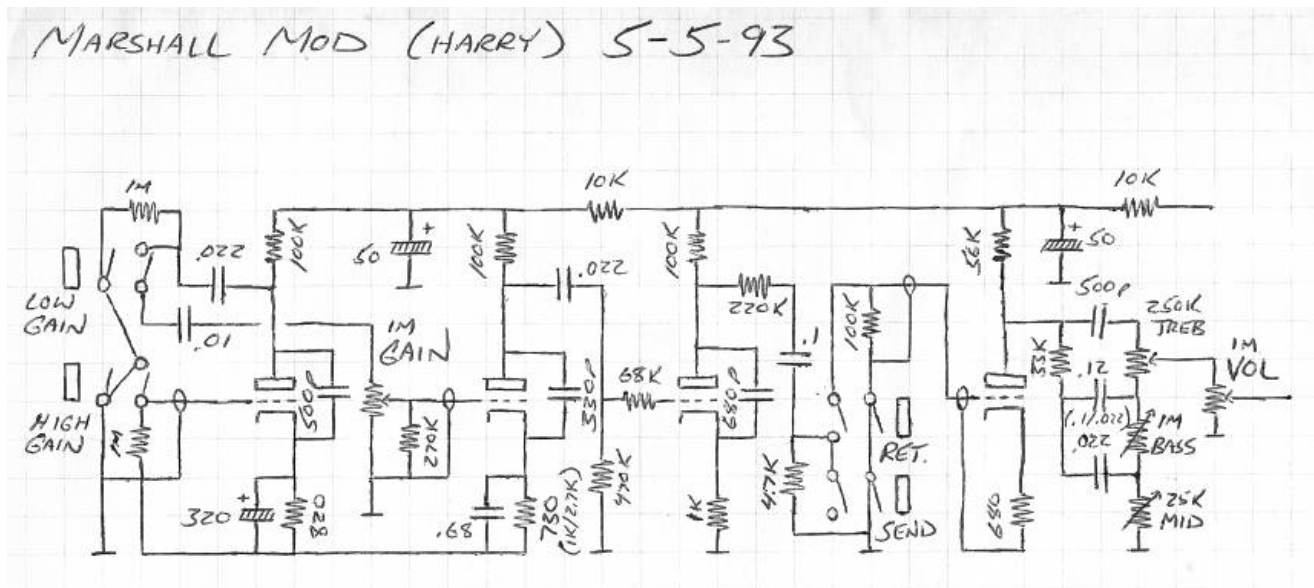

I really like this one... nice and simple and to the point, no holes or extra tubes needed. The effects loop level depends on if overdriven or not, oh well. At least it has a fairly low output impedance. I don't remember much about the amp this was done to, pretty sure it was a plain 50 watt.

3/8/95 - Theoretical Fender Bassman Overdrive/Switching/Loop Rebuild

BASSMAN MOD 8-MAR-95 WTN
CLEAN/OVERDRIVE SWITCHING 50 WATTS

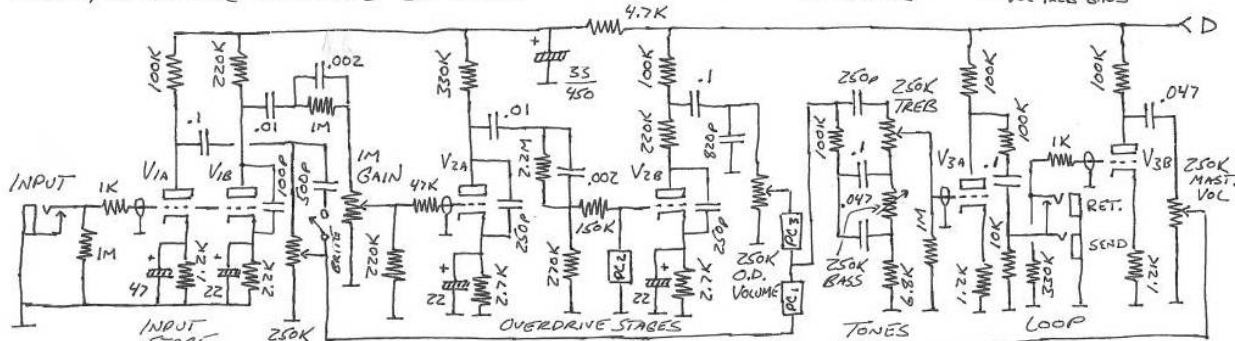
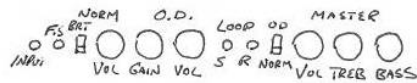

COMPONENT VALUES SUBJECT TO CHANGE
 PLATE CAPACITORS 600V (DISKS 1KV)
 PLATE RESISTORS 1/2W 5%
 OTHER CAPACITORS 250V, CATHODE CAPS 25V
 OTHER RESISTORS 1/4-1/2W 5%
 CONTROLS AUDIO TAPER

- PARTS LIST...
- | | |
|------------------|---------------------|
| 1 50 WATT OUTPUT | 7 2.5A1KV |
| 1 50 WATT POWER | 1 PL HOLDER |
| 1 100/100 CAP | 1 Toggles |
| 3 22/25 CAPS | 1 CO. Toggle (60T) |
| 1 47/25 CAP | 5 .1 600V CAPS |
| 3 20/500 CAPS | 2 .1 250V CAPS |
| 2 100/350 CAPS | 1 .047 600V CAP |
| 1 33/450 CAP | 1 .047 250V CAP |
| 2 5881 MATCHED | 2 .01 600V CAPS |
| 1 12AT7 | 1 10K BIAS POT |
| 3 12AX7 | 1 POWER CORD |
| 1 CHOKE | 2 8 PIN CERAMIC |
| 3 PHOTO COUPLERS | 4 9 PIN CERAMIC |
| 5 250K AUDIO | 6 S.C. 1/4" JACKS |
| 1 1M AUDIO | 2 1K 2W RESISTORS |
| 1 .022UF UL CAP | 3 470 2W RESISTORS |
| | 1 10K 2W RESISTORS |
| | 2 220K 1W RESISTORS |

LOTS OF SMALL RESISTORS & CAPS
 SHIELDED WIRE
 CLOTH WIRE - BK, RD, GRN, BLU, WHI
 2 SLIDE SWITCHES
 1 GUIDED OUTLET (MMI LINE-2)

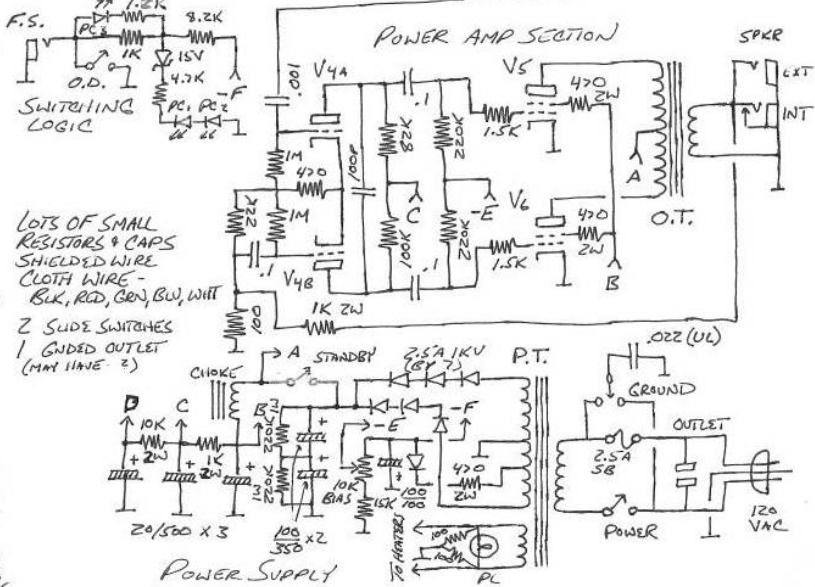

This amp was never made but it's a pretty cool design, fairly simple but provides the essentials. It should work pretty much as drawn but I see one potential mistake, the channel switching draws a variable amount of current from the bias supply which will vary its voltage. If actually attempting to make this thing the 470 ohm 2 watt in the bias supply should be changed to 100 ohm 2 watt (flameproof) or something similar to reduce the amount of variance, might have to reduce the 15K on the bias pot to 12K or so if the bias won't go low enough from the increased voltage. Pretty much the same old stuff except the clean/dirty split is at the input rather than after the 1st stage so more gain can be used and to avoid distorting the clean channel, the low-cut on the low-compensated gain control includes a resistor to provide a limit to the cut, and the channel switching network gets two photocell switching "phases" out of a single footswitch by using a zener diode. The reason for the parts list is I had a stripped chassis I was going to do the mod on. What actually got built is on the next page.

5/28/95 - Fender Bassman Boost/Overdrive/Switching/Loop Rebuild

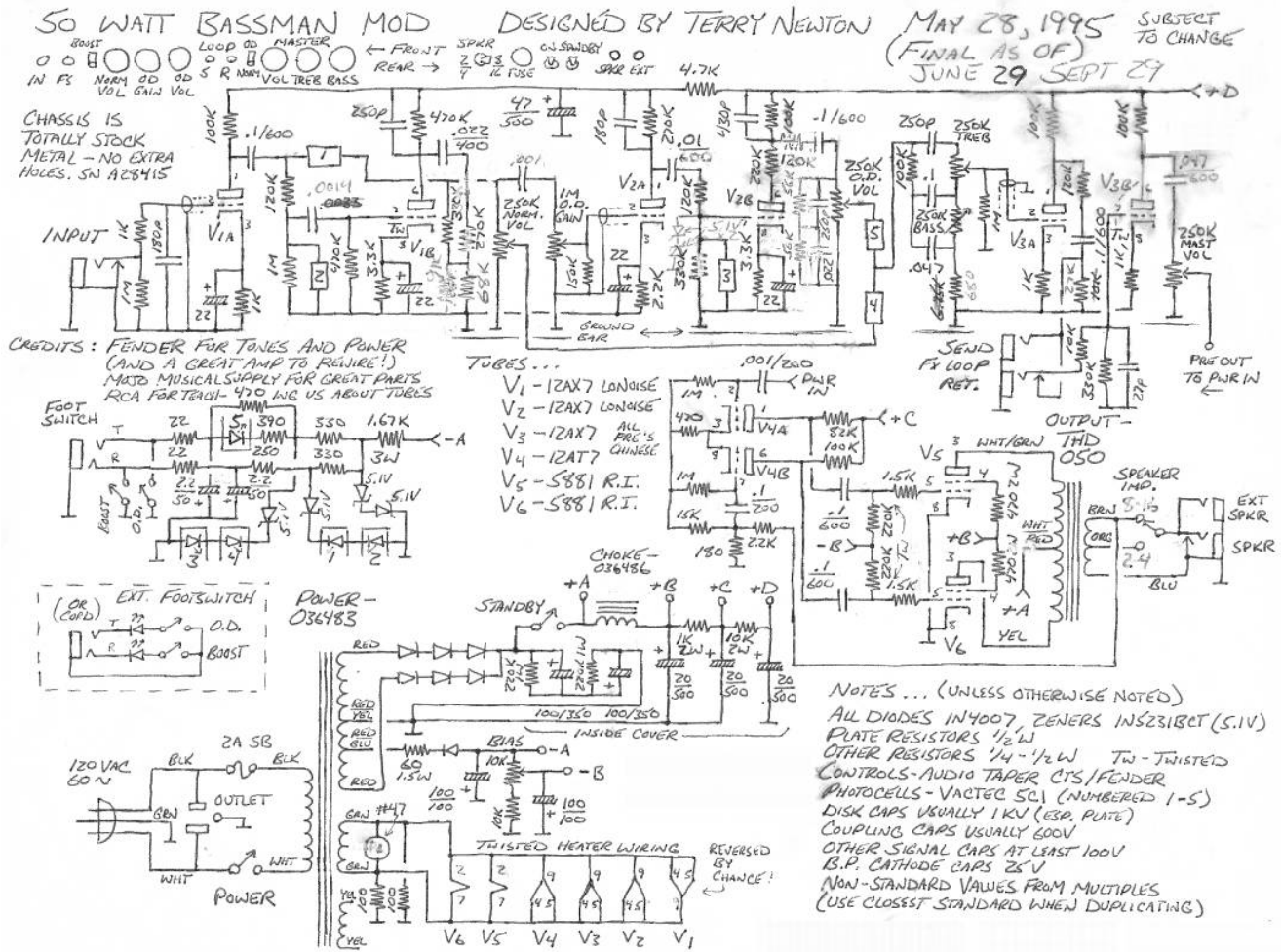

This amp turned out nice and simple, was able to get foot-switchable clean, boost, overdrive and radical settings using only 6 knobs. The switching network is similar to the 3/8/95 initial design except it's doubled to also switch the boost circuit in and out, and uses a pair of 5.1V diodes to regulate the voltage to 10.2 volts and avoid varying current drain from the bias supply, which had its series resistor lowered to 60 ohms to supply the necessary current. With no adjustment of the boost level and pre-clip/post-clip EQ it needed a few tweaks over the next few months to get "just right". This schematic was in poor condition and some of the changes are barely legible. The input cap for the boost stage was changed to .0014uF, a 91K was added parallel to the 68K to lower the boost level, the input to the gain control was changed from whatever it was to .001uF, a pair of 5.1V zeners back-to-back was added to the clip stage grid to even it out, and to filter and adjust the overdrive harmonics a 120K was added in series with the cap leading to the overdrive volume control and a pair of 56K resistors in series was added from the control hot to ground, across one was a 250pF cap to filter out some of the high harmonics, and a .022uF cap was placed across the other to boost up the low harmonics. There is no mid control, the fixed mid resistor ended up getting lowered to 680 ohms. The resistor which sets the FX send level was raised from 10K to 27K to make up for the volume loss from the other tweaks. Keep in mind that these tweaks were made to optimize the tone for a particular customer with a particular guitar running through particular speakers (JBL's if I recall so there's probably more high filtering than usual). The customer tended to play mostly at lower volume levels, thus the extra post-clip bass boost and mid cut. The initial values sounded fine to me using my equipment, as usual YMMV.

3/10/96 - Fender Bassman Boost/Overdrive/Switching/Loop Mod

MODIFIED BASSMAN

MAR. 10 1996

CHASSIS AB165
(SILVERFACE)

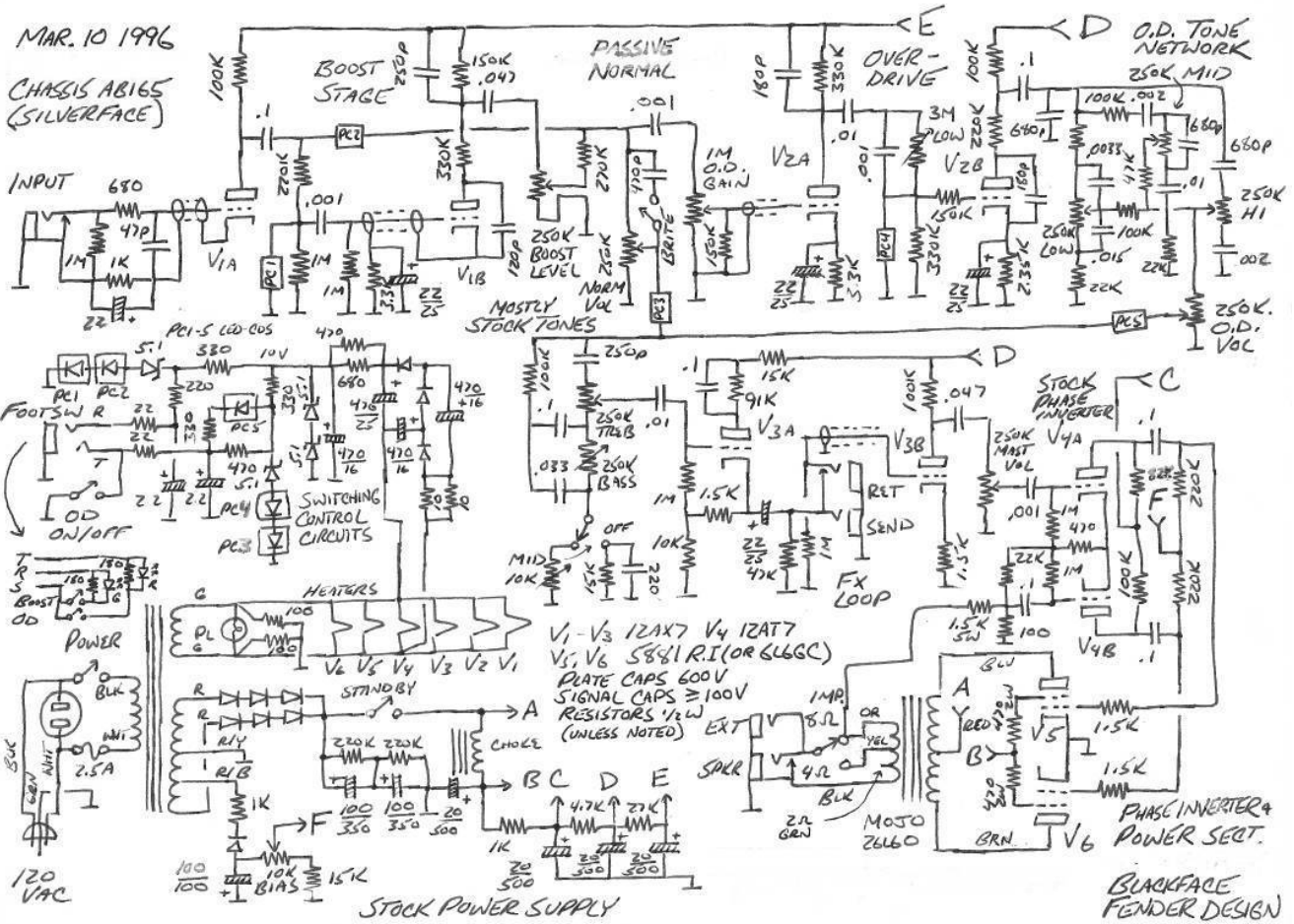

This is along the same line of thinking as the 5/28/95 mod but this time I drilled holes and used knobs for the tweaks to provide a boost level, a pre-clip EQ adjustment and low/mid/high tone adjustment controls post-clip (and didn't have to do post-mod tweaks). The unlabeled resistor attached to the post-clip low control is probably 100K. The loop uses a cathode-follower buffer off of the main tones to drive the effects send with a low source impedance. The photocell switching network uses the zener trick but gets its voltage from the heater supply rather than the bias supply. The mid control has a switch on it so when clicked "off" it inserts a fixed mid boost for "loud" playing.

11/3/06 - Marshall Overdrive/Loop Mod

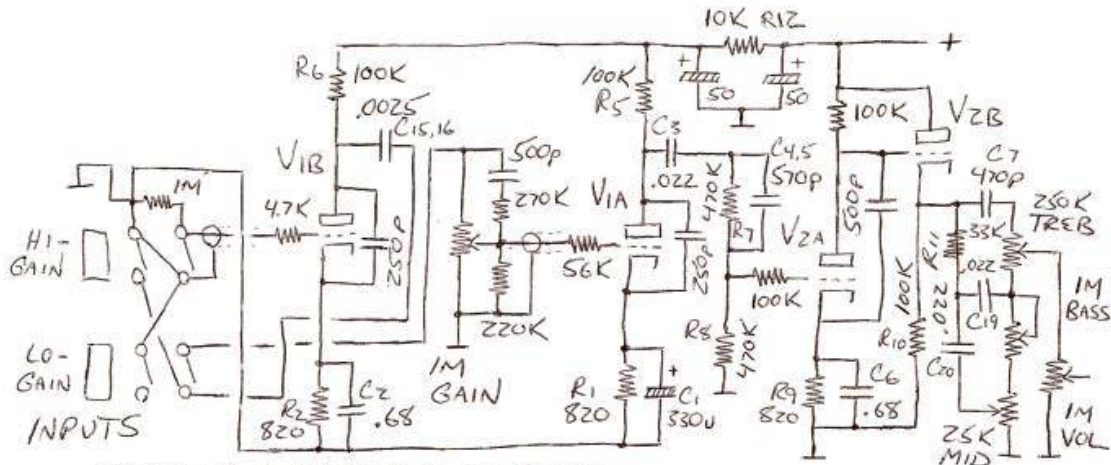

R/C #'S FROM 1959SLP-60-00 BOARD,
 R3, R4, R22, R23, C17, C18, C21 REMOVED
 C8 (PI INPUT) CHANGED TO 1000pF,
 4.7K INSERTED WHERE C21 WAS, TO SERIES WITH C8
 SUPER LEAD 100W REISSUE, #93115904
 11-2-06 WTN

MOSTLY A "STOCK" MOD
 USING EXISTING VALUES,
 REARRANGED FOR GAIN
 WITH R/C'S ON THE
 TUBES TO STABILIZE.

EFFECTS LOOP...
 ADDED 11-3-06 WTN

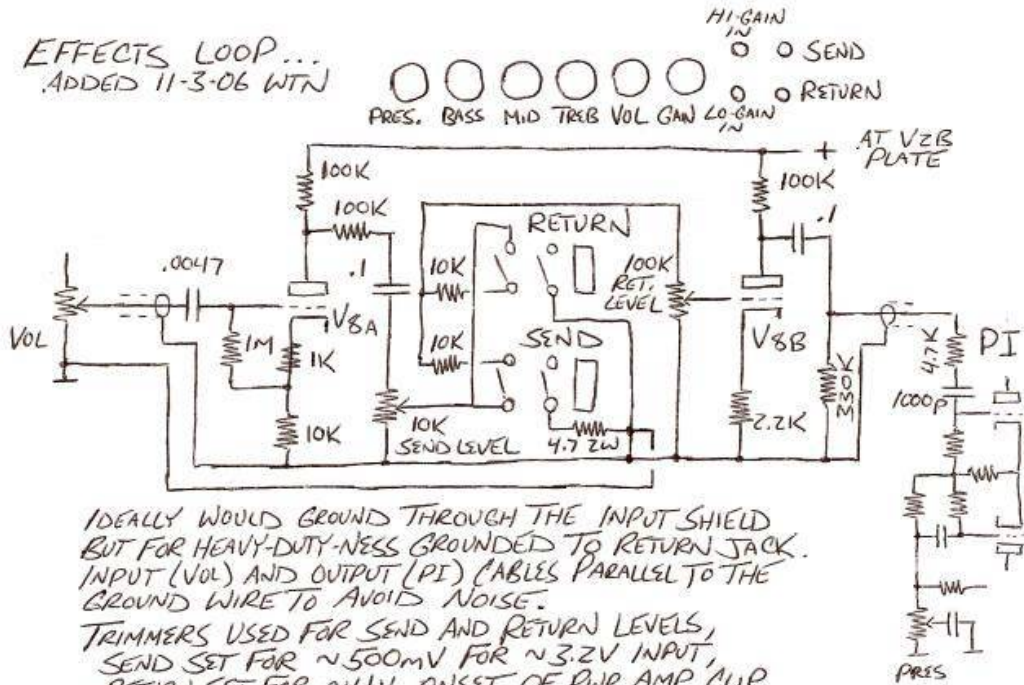

IDEALLY WOULD GROUND THROUGH THE INPUT SHIELD
 BUT FOR HEAVY-DUTY-NESS GROUNDED TO RETURN JACK.
 INPUT (VOL) AND OUTPUT (PI) CABLES PARALLEL TO THE
 GROUND WIRE TO AVOID NOISE.
 TRIMMERS USED FOR SEND AND RETURN LEVELS,
 SEND SET FOR ~500mV FOR ~3.2V INPUT,
 RETURN SET FOR ~4V, ONSET OF PWR AMP CLIP
 NOTE - BOTH SEND AND RETURN HAVE TO BE USED
 TO BREAK THE SIGNAL PATH, SEND BY ITSELF IS A LINE OUT,
 RETURN BY ITSELF MIXES WITH THE PREAMP SIGNAL.

This is one of my neatest-looking mods, has a few extra parts hanging off controls and tube sockets but not too bad, almost could be mistaken for stock until I wired the effects loop on a piece of fiberboard with eyelets. Photos on the next page.

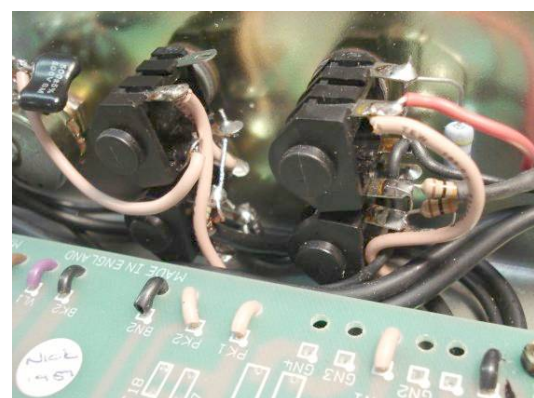
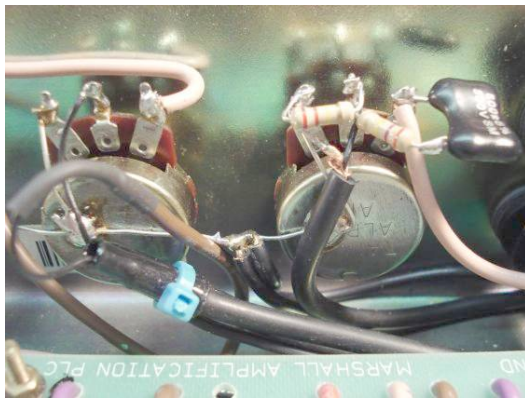
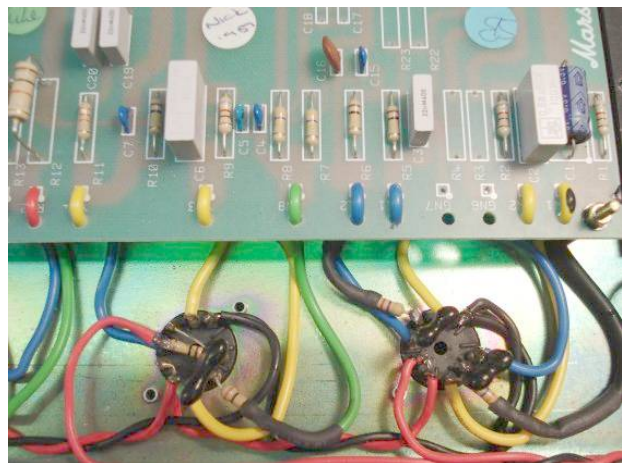
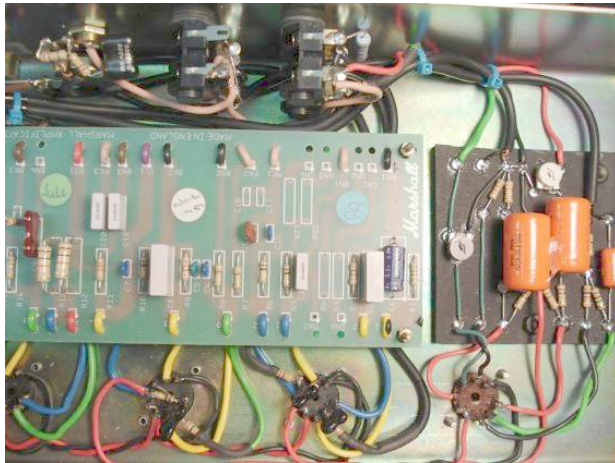
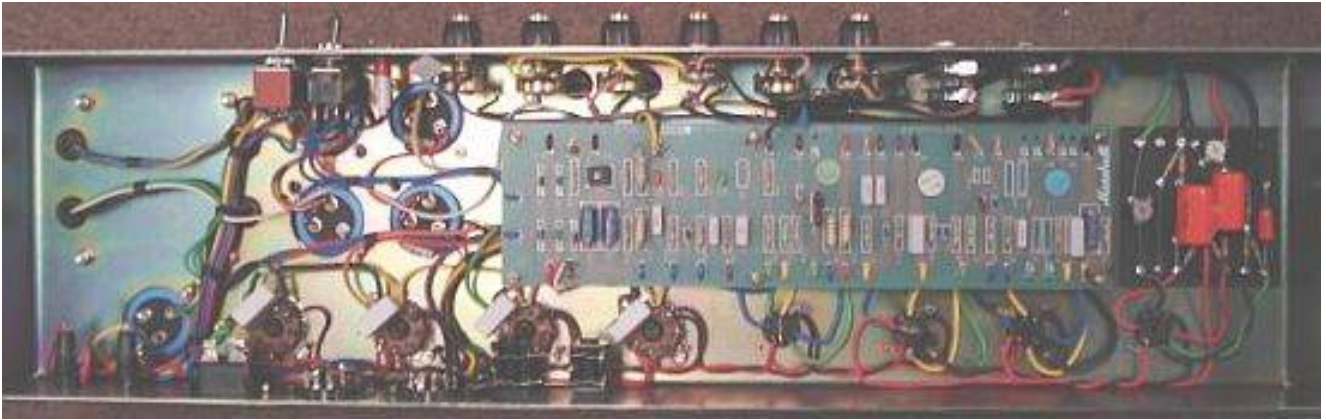

12/5/07 - Fender 75 Overdrive/Switching/Loop Mod

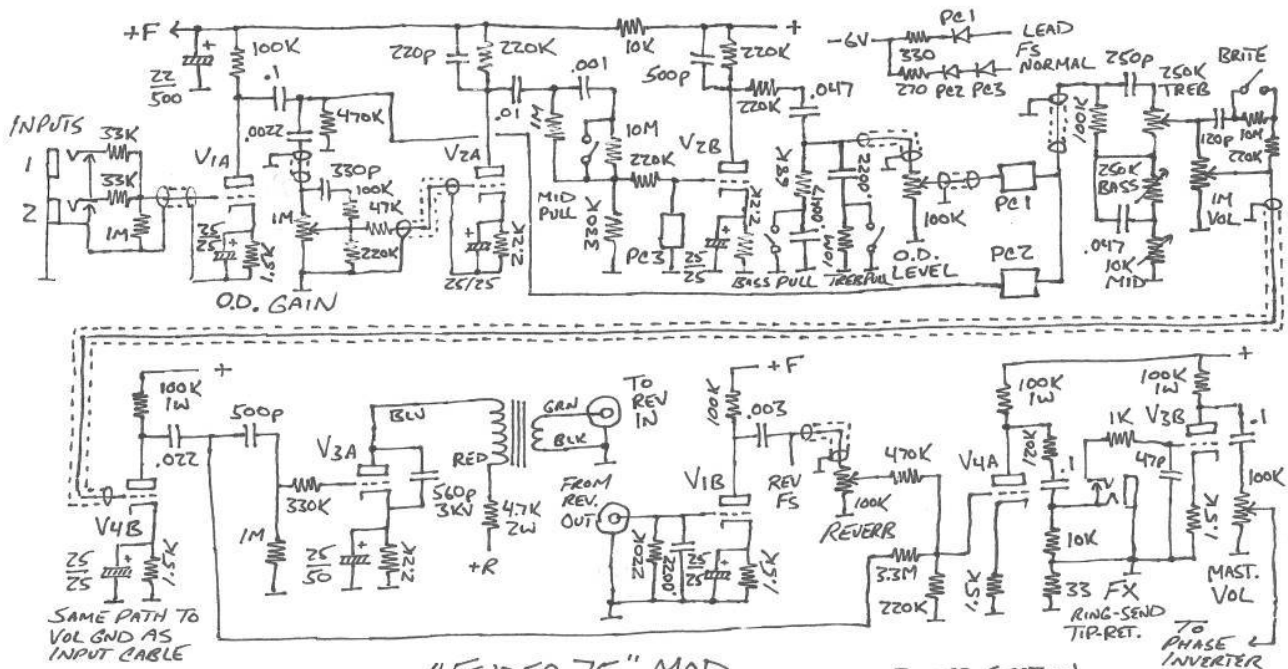

FOOTSWITCH JACKS...

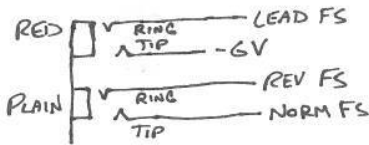

"FENDER 75" MOD
 SN F063147 12-5-07 WTN
 NO SEPARATE CLEAN CHANNEL,
 VOL TREB MID BASS & MASTER
 ALWAYS ON OVERDRIVE GAIN
 AND LEVEL ("LEAD MASTER") ADDED
 PRE-TONE WHEN ENGAGED.
 PULL SWITCHES AFFECT O.D. ONLY
 (MID AND HIGH PULLS BACKWARDS)
 FOOTSWITCH MUST BE PLUGGED IN
 OR NO OUTPUT.

POWER SECTION
 WAS PREVIOUSLY MODIFIED
 WITH "REBULAR" OUTPUT TRANS,
 470 OHM SCREEN GRID R'S
 RUNNING FROM CHOKE/CAP
 FILTER SECTION...

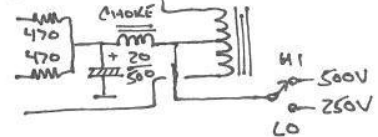

The owner of the 3/16/92 mod gave a friend of ours an old ragged out Fender 75 on the condition he took it to me to get it souped up... ok sure! Only I forgot how. One of the main reasons I'm making this document is to preserve old information, got through the mod, amp came out fine but afterwards I found my old mod notes and scanned them in so the info will be there when I need it.

This 75 mod has a cleaner clean than the previous, very similar to a regular Fender Reverb signal path. I didn't have a 10pF handy to put across the 3.3 meg in the reverb circuit, it came out a tiny bit darker as a result (its dark-sounding speaker with a square magnet doesn't help). All of the pulls are assigned to various overdrive tweaks. Unlike the previous 75 mod this one doesn't have a separate clean channel, the overdrive functions as if it were connected in front of an otherwise clean amp. The bright switch affects the overdrive too, the treble pull adds quite a bit of high-cut to make settings like that work. It cleans up very nicely when the guitar volume is backed off but it does need to be dialed in right. Assigning the tube sections is a tricky aspect, this time around I paired of the input and reverb pickup, gain and clip, tone pickup and reverb mix, and reverb drive and effects return (the 12AT7). Works. Many of the components were chosen from the parts left over from taking apart the preamp so some of the values were chosen somewhat arbitrarily (then again I couldn't remember previous values so might as well... guesses came out "close enough" to think I'd better leave it alone). Photo-coupler PC3 was salvaged from a PolyTone amp. Got lucky, no feedback chirp when switching. Photos on the next page.

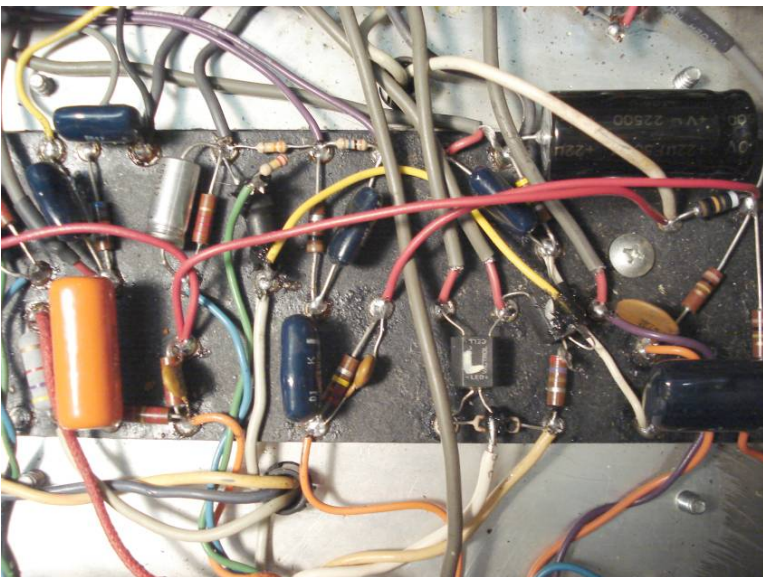
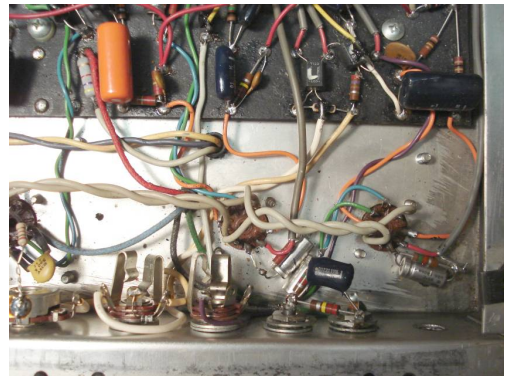
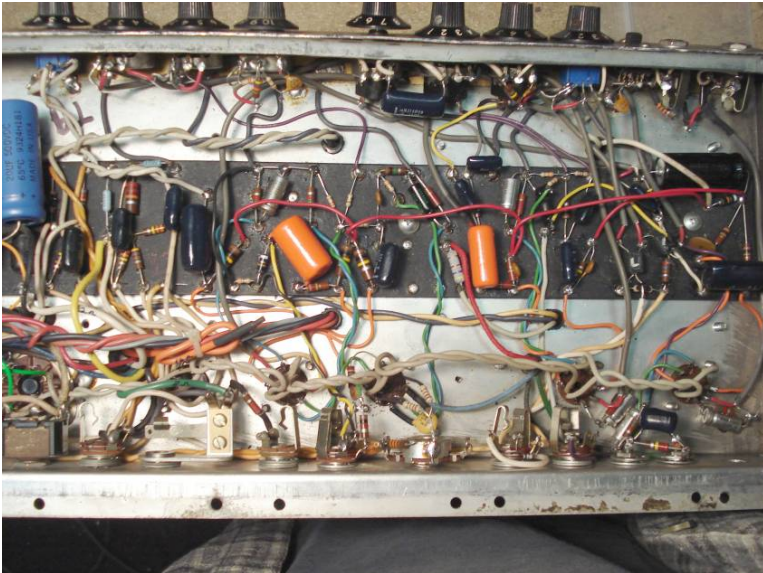

And finally...

This is documentation for the mods I've done, preserved before the paperwork turns to dust and I no longer can recall the details (which for some details already is the case). I don't represent that my overdrive designs are best for everyone, or that they're anything at all, this is just history. It is funny though how over time amps evolved to sound more like my designs than not. Some amps have always pretty much got it "right". For some. Others just aren't into preamp distortion and won't be happy no matter how carefully all the parameters are tweaked. Some like the tone of tones before the clip stage, particularly at high volume. A few amp designs have made that work quite well but they still tend to sound not so great at lower volumes unless a graphic EQ is used - and that is probably the best architecture of all, tones before and after the clip stage. Just never had enough knob positions to provide more than one or two pre-clip tones, it was the post-clip tone my customers were concerned with. We'd just get the pre-clip tone close enough so compensated gain controls and the guitar's volume and tone can do that job without requiring a slew of knobs that often don't do much when turned.

Then there's the issue of intellectual property rights, patents and all that nasty money-grubbing stuff. Some may think I'm nuts for publishing my "secrets" but I counter with the following points...

1) Most (if not all) of "my" design details are obvious to those skilled in the art. Low notes take over high notes, obviously the lows have to be reduced. Happens more at high gain settings, obviously more lows have to be rolled off as the gain goes up. Tones don't adjust clip harmonics, obviously they need to be placed afterwards, then they do. Can't get the treble over "1", obviously needs additional filtering. That makes it sound dark, obviously the highs need boosting pre-clip to make up for that.

2) There is little profit in doing mods. It's at best a break-even thing. Let's see... spend 2 hours resoldering a typical "inexpensive" amp that otherwise sounds fine, customer pays roughly \$100 labor, I make about \$25 an hour for as long as I can keep working on viable repairs (dogs ensure I average less). Spend 3 days building a mod amp, customer pays roughly \$350 labor, I make about \$10 an hour and nothing on after-tweaks. Needless to say I don't do many mods these days, but I still enjoy doing them because it's an opportunity to create new tone.

3) I almost unknowingly violated a patent with my "super" champ design... one detail different and I would have. The reason I didn't do it in the way that would have violated is I wasn't going for "mosfet" sound and considered that an artifact that should be corrected. I see many patented designs that are chock-full of other people's circuits or are just plain obvious. The recent trend of patenting software is very disturbing, it is now difficult to write any significant computer program without unknowingly violating something... everything from progress bars to the "is not" operator is patented, companies exist just to file/buy junk patents then go after other companies who were doing it that way all along. Patents should be limited to true inventions, not stringing together a bunch of obvious stuff.

Contact Information (updated 5/12/16, my shop moved back Old Hickory):

Terry Newton
Superior Music / The Amp Doctor
3610 Old Hickory Blvd
Old Hickory, TN 37138
(615) 847-9687