

GWC Valve International



PROVEN TECHNOLOGY FOR INDIVIDUAL VALVE SOLUTIONS - WORLDWIDE

TRUNNION MOUNTED BALL VALVES

PRESSURE CLASS:

ASME 150-2500

API 2000-5000

SIZE RANGE: 2" - 48"

API STANDARDS: 6D & 6A

ASME B16.34

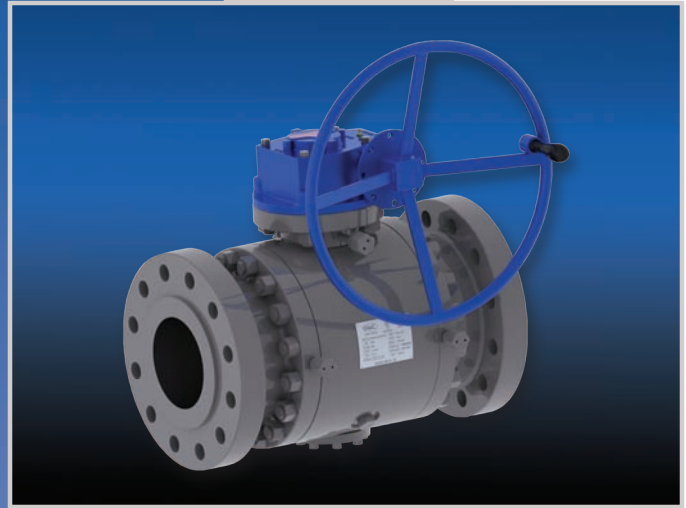

CATALOG NUMBER TBV-1001



TABLE OF CONTENTS

STANDARD FEATURES

Forged Body Trunnions	4
Cast Body Trunnions	6
Ordering Guide	8

STANDARD PRODUCTS

Trunnion Valves	9
Pressure/Temperature Charts	20
Terms and Conditions of Sale	21
Return Goods Policy and Warranty	22



API-6FA firesafe test in process at Anderson & Associates in Houston, Texas.



Successfully completed firesafe test.

STANDARD FEATURES

TRUNNION BALL VALVE 2" TO 16" CLASS 150-2500

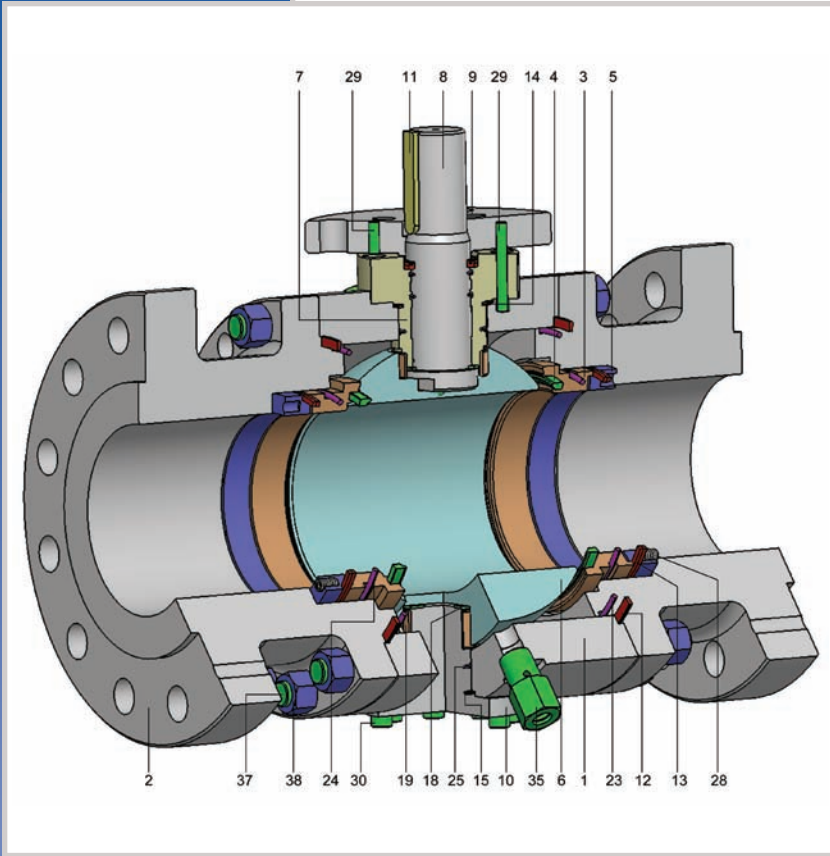

The GWC forged body trunnion mounted ball valves are designed, constructed and tested according to API-6D. The full range of GWC Trunnion Ball Valves are supplied standard in full compliance with NACE MR-01-75.

GWC ball valves have been developed for oil and gas pipelines, and process industry use according to API-6D standards.

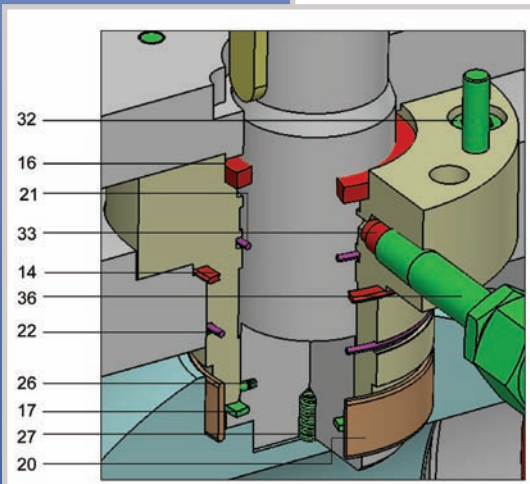

GWC forged body standard trunnion mounted ball valves are furnished with the following fire-safe materials:

- | | |
|--------------------------------|---------------------------------|
| 1. Body | 22. Gland O-Ring |
| 2. Cap | 23. Body O-Ring |
| 3. Seat Ring | 24. Seat O-Ring |
| 4. Seat | 25. Trunnion O-Ring |
| 5. Spring Plate | 26. Anti-Static Spring And Ball |
| 6. Ball | 27. Anti-Static Spring |
| 7. Gland | 28. Spring |
| 8. Stem | 29. Pin |
| 9. Adaptor Plate | 30. Screw |
| 10. Trunnion | 31. Screw (Not shown) |
| 11. Key | 32. Screw |
| 12. Body Fire-Proof Gasket | 33. Burried Check |
| 13. Seat Fire-Proof Gasket | 34. Vent Valve (Not shown) |
| 14. Gland Fire-Proof Gasket | 35. Drain Valve |
| 15. Trunnion Fire-Proof Gasket | 36. Stem Injection |
| 16. Graphite Stem Seal | 37. Stud |
| 17. Thrust Washer | 38. Nut |
| 18. Trunnion Gasket | |
| 19. Bearing | |
| 20. Bearing | |
| 21. Stem O-Ring | |

Note: 6" and above: Seat Injection & Buried Check are standard and are not shown.

STANDARD FEATURES

TRUNNION BALL VALVE 18" AND ABOVE CLASS 150 TO 2500

The GWC forged body trunnion mounted ball valves are designed, constructed and tested according to API-6D. The full range of GWC Trunnion Ball Valves are supplied standard in full compliance with NACE MR-01-75.

GWC ball valves have been developed for oil and gas pipelines, and process industry use according to API-6D standards.

GWC forged body standard trunnion mounted ball valves are furnished with the following fire-safe materials:

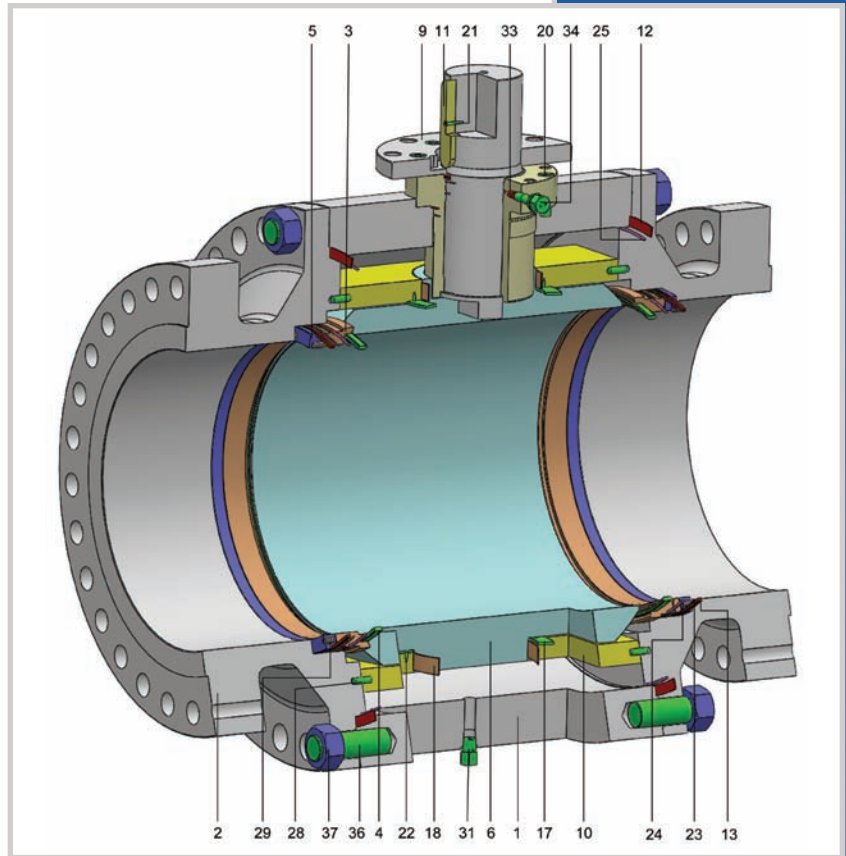

- | | |
|-----------------------------|---------------------------------|
| 1. Body | 25. Body O-Ring |
| 2. Cap | 26. Gland O-Ring |
| 3. Seat Ring | 27. Stem O-Ring |
| 4. Seat | 28. Pin |
| 5. Spring Plate | 29. Spring |
| 6. Ball | 30. Anti-Static Spring And Ball |
| 7. Gland | 31. Drain Valve |
| 8. Stem | 32. Vent Valve (Not shown) |
| 9. Adaptor Plate | 33. Buried Check |
| 10. Bearing Plate | 34. Stem Injection |
| 11. Key | 35. Seat Injection (Not shown) |
| 12. Body Fire-Proof Gasket | 36. Stud |
| 13. Seat Fire-Proof Gasket | 37. Nut |
| 14. Gland Fire-Proof Gasket | |
| 15. Graphite Stem Seal | |
| 16. Thrust Washer | |
| 17. Ball Thrust Bearing | |
| 18. Bearing | |
| 19. Screw | |
| 20. Screw | |
| 21. Key Screw | |
| 22. Bearing Screw | |
| 23. Seat O-Ring | |
| 24. Seat O-Ring | |

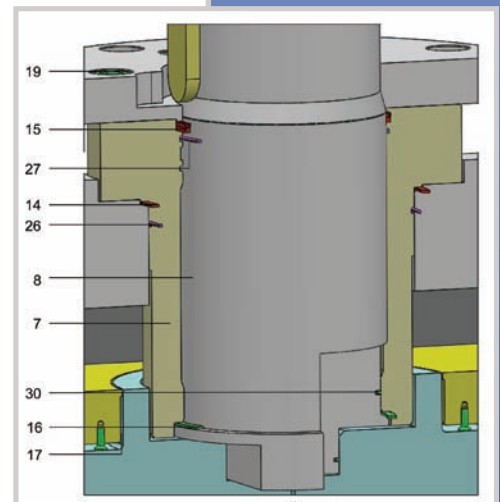

STANDARD FEATURES

CAST BODY TRUNNIONS

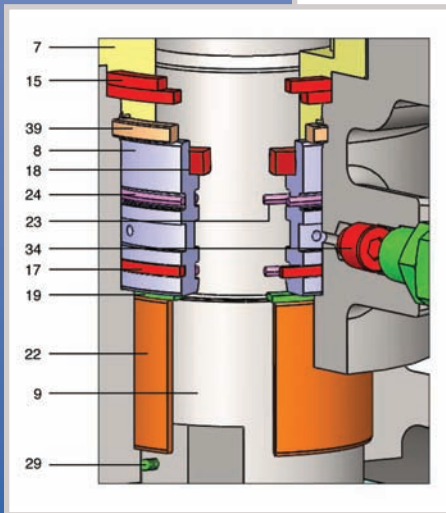
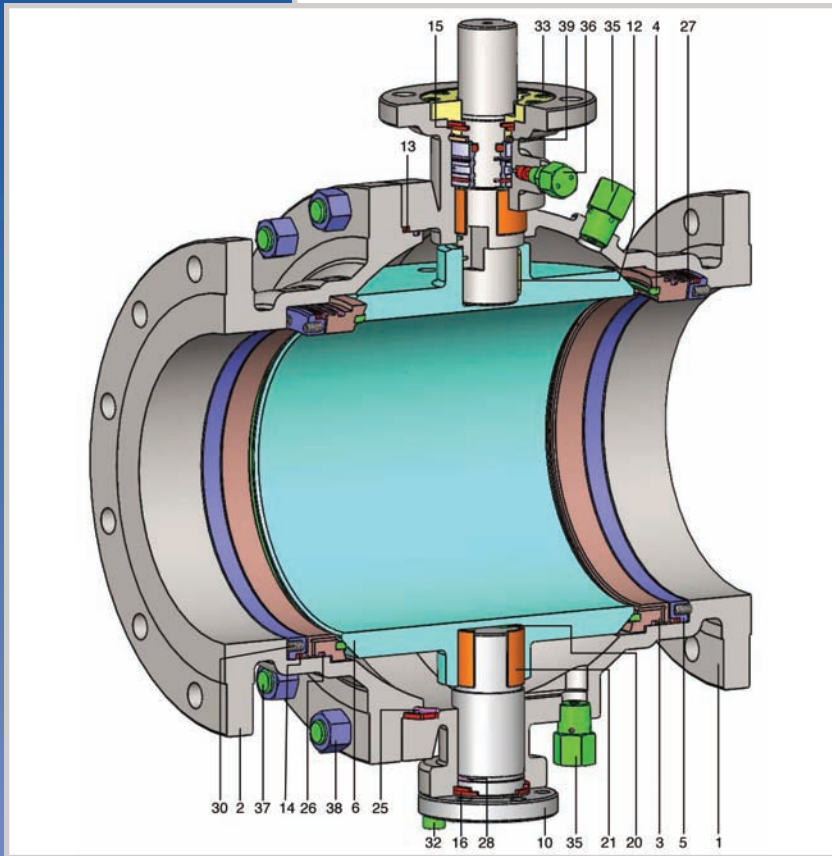

GWC cast body trunnion mounted ball valves are designed, constructed and tested according to API-6D. The full range of GWC Trunnion Ball Valves are supplied standard in full compliance with NACE MR-01-75.

GWC ball valves have been developed for oil and gas pipelines, and process industry use according to API-6D standards.

GWC cast body standard trunnion valves are furnished with the following fire-safe materials:

1. Body
2. Cap
3. Seat Ring
4. Seat Inserts
5. Seat Spring
6. Ball
7. Gland Flange
8. Gland Bush
9. Stem
10. Trunnion
11. Key
12. Ball Joint Key
13. Body Fire-Proof Gasket
14. Seat Fire-Proof Gasket
15. Gland Fire-Proof Gasket
16. Trunnion Fire-Proof Gasket
17. Gland Bush Fire-Proof Gasket
18. Graphite Stem Seal
19. Stem Thrust Washer
20. Trunnion Thrust Washer
21. Bearing
22. Bearing
23. Stem O-Ring
24. Gland O-Ring
25. Body O-Ring
26. Seat O-Ring
27. Seat O-Ring
28. Trunnion O-Ring
29. Anti-Static Spring And Ball
30. Spring
31. Pin
32. Screw
33. Screw
34. Buried Check
35. Drain & Vent Valve
36. Stem Injection
37. Stud
38. Nut
39. Stop Ring

Note:

6" and above - Seat Injection and Buried Check are standard and are not shown.

STANDARD FEATURES

DOUBLE BLOCK AND BLEED

With the ball in open position, the upstream and downstream seats are forced against the ball by the line pressure. With the ball in the closed position the upstream seat is forced against the ball by the line pressure. The downstream seat is forced against the ball by the springs. The vent and drain valves allow the bleeding off of trapped body cavity pressure. This double block and bleed function makes it possible to flush the valve under pressure and verify the seats are sealing properly. (Figure 1)

Figure 1

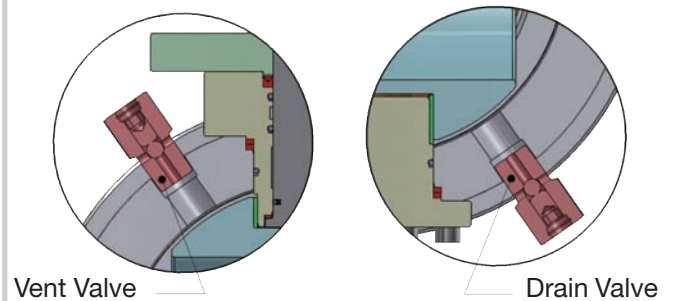

SEALING FEATURE

All Trunnion ball valves utilize the differential between the sealing diameter of the seat insert/ball contact and the outer diameter of the seat. The difference between these areas times the line pressure is the sealing force. When line pressure is so low that the force generated by the different diameters cannot seal, the seat springs provide the force. (Figure 2)

Figure 2

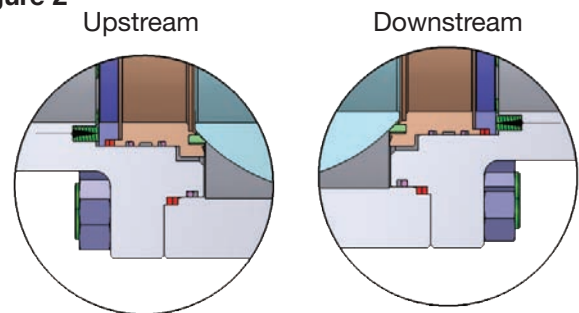

FIRE SAFE DESIGN FEATURE

GWC Trunnion Ball valves are designed with a secondary metal-to-metal seal after a fire. When the primary soft seals are destroyed by fire, the fire-safe seals energize the seat assembly to seal. The differential seat area energized by line pressure with the spring force loads the seat into the ball. All GWC Model FF and GG Trunnion Mounted ball valves have been tested to API-607/API-6FA. (Figure 3)

Figure 3

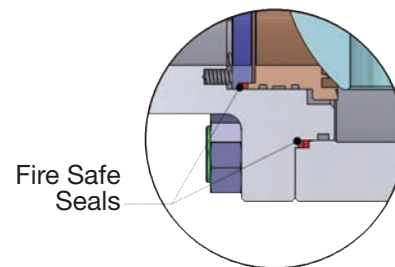

INJECTION SEALANT FEATURE

The full range of Trunnion Ball Valves are supplied with a standard anit-blow out stem and stem sealant injection fitting. Seat sealant fittings are also standard on the 6" and larger valves. These sealant fittings can be used to provide a temporary seal in the event of damage incurred from fire or line media contamination.

(Figure 4)

Figure 4

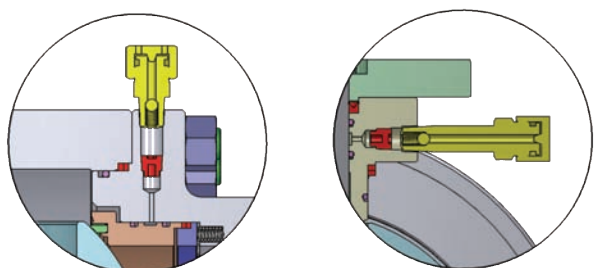

Example: 12" Figure # FF600-1-CF-E2-GO

FF	60	0	-	1	-	CF	-	E	2	-	GO
1.	2.	3.		4.		5.		6.	7.		8.

12" CLASS 600 TRUNNION BALL VALVE, FLG-RF, FULL BORE, A105 BODY x A105 + ENP TRIM, DEVLON SEAT INSERTS, VITON-B, O-RINGS, NACE, FIRESAFE, GEAR OP.

1. MODEL

F - TRUNNION BALL, 2 PIECE, SPLIT BODY, FULL BORE	FT - TRUNNION BALL, 1 PIECE, TOP ENTRY, FULL BORE
G - TRUNNION BALL, 2 PIECE, SPLIT BODY, REDUCED BORE	GT - TRUNNION BALL, 1 PIECE, TOP ENTRY, REDUCED BORE
FF - TRUNNION BALL, 3 PIECE, SPLIT BODY, FULL BORE	FW - TRUNNION BALL, FULLY WELDED BODY, FULL BORE
GG - TRUNNION BALL, 3 PIECE, SPLIT BODY, REDUCED BORE	GW - TRUNNION BALL, FULLY WELDED BODY, REDUCED BORE

2. RATING

15 - CLASS 150	150 - CLASS 1500
30 - CLASS 300	250 - CLASS 2500
60 - CLASS 600	300 - API 3000
90 - CLASS 900	500 - API 5000

3. END CONNECTION

0 - RF FLANGED	9 - RING JOINT
7 - BUTTWELD (SCHEDULE REQUIRED)	X - SPECIAL

4. TYPE

1 - FIRE-SAFE

5. MATERIAL (BODY + TRIM)

AC - WCB + 304	GC - LCC + 316	NF - F316L + 316L
AF - A105 + 304	GF - LF2 + 316	OC - CN7M + A/20
BC - WCB + 316	HC - LCB + LF2/ENP	OF - A/20 + A/20
BF - A105 + 316	IC - LCB + F6A/13CR	PC - A890-4A + F51
CC - WCB + A105/ENP	JC - LCB + 316	PF - F51 + F51
CF - A105 + A105/ENP	KC - CF8 + 304	QC - A890-5A + F53
DC - WCB + F6A/13CR	KF - F304 + 304	QF - F53 + F53
DF - A105 + F6A/13CR	LC - CF8M + 316	RC - A890-6A + F55
EC - LCC + LF2/ENP	LF - F316 + 316	RF - F55 + F55
EF - LF2 + LF2/ENP	MC - CF3 + 304L	X - SPECIAL
FC - LCC + F6A/13CR	MF - F304L + 304L	
FF - LF2 + F6A/13CR	NC - CF3M + 316L	

6. MATERIAL (SEAT)

G - RTFE	V - PEEK	X - SPECIAL
B - NYLON	J - DELRIN	
E - DEVLON	M - METAL	

7. MATERIAL (O-RING SEAL)

1 - HNBR	4 - EPDM
2 - VITON-B	5 - AFLAS
3 - VITON GLT	X - SPECIAL

8. OPERATOR

L - HANDWHEEL OPERATOR	GO - WORM GEAR OPERATOR	B - BARE STEM
------------------------	-------------------------	---------------

9. SPECIAL REQUIREMENTS

EB - EXTENDED BONNET	S - SUPPLY COMPLETE INFORMATION
----------------------	---------------------------------

CAST TRUNNION BALL VALVE

MODEL F150/G150, FF150/GG150

Construction: Split body, 2-piece or 3-piece, trunnion mounted ball, Double seal design, double block and bleed, anti-blow out stem, anti-static device, firesafe to API-607/API-6FA, spring loaded seats, designed according to API-6D

Dimensions

Face to Face	API-6D
End Flange	ASME B16.5
Rating	ASME Class 150

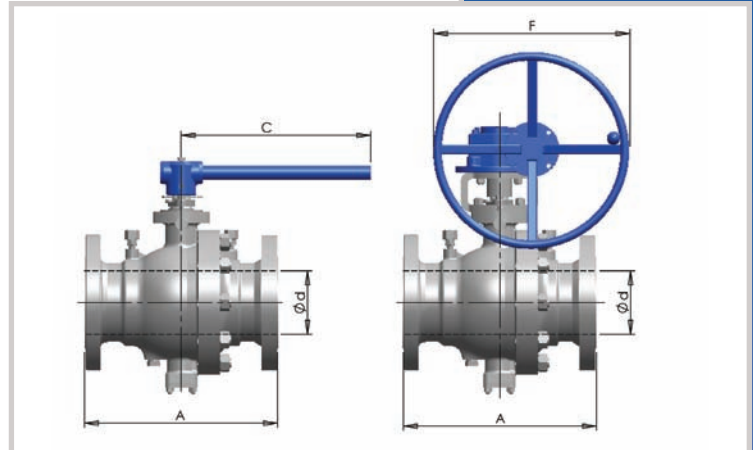

****NACE MR-01-75 Certified****

STANDARD MATERIALS

Figure Number: 2-Piece	F150-1-CC-G2, G150-1-CC-G2	F150-1-BC-G2, G150-1-BC-G2	F150-1-LC-G2, G150-1-LC-G2
Figure Number: 3-Piece	FF150-1-CC-G2, GG150-1-CC-G2	FF150-1-BC-G2, GG150-1-BC-G2	FF150-1-LC-G2, GG150-1-LC-G2
Body/Cap	A216 WCB	A216 WCB	A351 CF8M
Ball	A105N*	316SS	316SS
Stem	AISI 4140*	A182 F316	A182 F316
Seats & Inserts	ASTM A105N* + RTFE	A182 F316 + RTFE	A182 F316 + RTFE
O-Rings	Viton-B	Viton-B	Viton-B

* Electroless Nickel Plating .001"

Dimensions in inches

CLASS 150 • FULL BORE

Valve Size	2" 50mm	3" 80mm	4" 100mm	6" 150mm	8" 200mm	10" 250mm	12" 250mm	14" 350mm	16" 400mm	18" 450mm	20" 500mm	24" 600mm
Bore Size (d)	2.00	3.00	4.00	6.00	8.00	10.00	12.00	13.25	15.25	17.25	19.25	23.25
Face to Face (A)	RF	7.00	8.00	9.00	15.50	18.00	21.00	24.00	27.00	30.00	34.00	42.00
	BWE	8.50	11.13	12.00	18.00	20.50	22.00	25.00	30.00	33.00	36.00	45.00
Handle Length (C)	14.76	15.55	15.55	25.23	-	-	-	-	-	-	-	-
Handwheel Diameter (F)	-	-	18.11	18.11	18.11	24.00	24.00	24.00	24.00	24.00	28.00	28.00
Approx. Weight (lbs.)	50	94	158	287	440	678	989	1346	1813	2526	3165	5450

Larger sizes are available upon request.

Dimensions in inches

CLASS 150 • REDUCED BORE

Valve Size	3" 80mm	4" 100mm	6" 150mm	8" 200mm	10" 250mm	12" 250mm	14" 350mm	16" 400mm	18" 450mm	20" 500mm	24" 600mm
Bore Size (d)	2.00	3.00	4.00	6.00	8.00	10.00	10.00	12.00	13.25	15.25	19.25
Face to Face (A)	RF	8.00	9.00	15.50	18.00	21.00	24.00	27.00	30.00	34.00	42.00
	BWE	11.13	12.00	18.00	20.50	22.00	25.00	30.00	33.00	36.00	45.00
Handle Length (C)	14.76	15.55	15.55	25.23	-	-	-	-	-	-	-
Handwheel Diameter (F)	-	-	18.11	18.11	18.11	24.00	24.00	24.00	24.00	24.00	28.00
Approx. Weight (lbs.)	54	111	179	331	510	818	1094	1461	1901	2285	3605

Larger sizes are available upon request.

CAST TRUNNION BALL VALVE

MODEL F300/G300, FF300/GG300

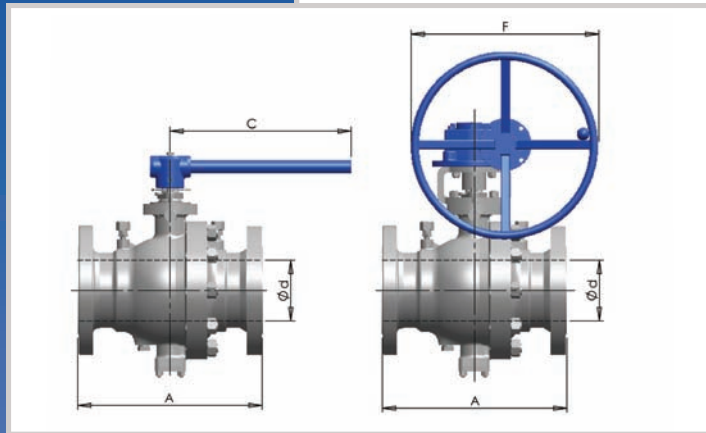

Construction: Split body, 2-piece or 3-piece, trunnion mounted ball, Double seal design, double block and bleed, anti-blow out stem, anti-static device, firesafe to API-607/API-6FA, spring loaded seats, designed according to API-6D

Dimensions

Face to Face	API-6D
End Flange	ASME B16.5
Rating	ASME Class 300

****NACE MR-01-75 Certified****

STANDARD MATERIALS

Figure Number: 2-Piece	F300-1-CC-G2, G300-1-CC-G2	F300-1-BC-G2, G300-1-BC-G2	F300-1-LC-G2, G300-1-LC-G2
Figure Number: 3-Piece	FF300-1-CC-G2, GG300-1-CC-G2	FF300-1-BC-G2, GG300-1-BC-G2	FF300-1-LC-G2, GG300-1-LC-G2
Body/Cap	A216 WCB	A216 WCB	A351 CF8M
Ball	A105N*	316SS	316SS
Stem	AISI 4140*	A182 F316	A182 F316
Seats & Inserts	ASTM A105N* + RTFE	A182 F316 + RTFE	A182 F316 + RTFE
O-Rings	Viton-B	Viton-B	Viton-B

* Electroless Nickel Plating .001"

CLASS 300 • FULL BORE

Dimensions in inches

Valve Size	2"	3"	4"	6"	8"	10"	12"	14"	16"	18"	20"	24"
	50mm	80mm	100mm	150mm	200mm	250mm	250mm	350mm	400mm	450mm	500mm	600mm
Bore Size (d)	2.00	3.00	4.00	6.00	8.00	10.00	12.00	13.25	15.25	17.25	19.25	23.25
Face to Face (A)	RF	8.50	11.13	12.00	15.88	19.75	22.38	25.50	30.00	33.00	36.00	45.00
	BWE	8.50	11.13	12.00	15.88	20.50	22.00	25.00	30.00	33.00	36.00	45.00
Handle Length (C)	12.40	19.49	21.46	25.23	-	-	-	-	-	-	-	-
Handwheel Diameter (F)	-	18.11	18.11	18.11	24.00	24.00	24.00	28.00	28.00	28.00	28.00	30.00
Approx. Weight (lbs.)	51	100	167	326	505	892	1302	1766	2112	2860	3884	6107

Larger sizes are available upon request.

CLASS 300 • REDUCED BORE

Dimensions in inches

Valve Size	3"	4"	6"	8"	10"	12"	14"	16"	18"	20"	24"
	80mm	100mm	150mm	200mm	250mm	250mm	350mm	400mm	450mm	500mm	600mm
Bore Size (d)	2.00	3.00	4.00	6.00	8.00	10.00	10.00	12.00	13.25	15.25	19.25
Face to Face (A)	RF	11.13	12.00	15.88	19.75	22.38	25.50	30.00	33.00	36.00	45.00
	BWE	11.13	12.00	15.88	20.50	22.00	25.00	30.00	33.00	36.00	45.00
Handle Length (C)	12.40	19.49	21.46	25.23	-	-	-	-	-	-	-
Handwheel Diameter (F)	-	18.11	18.11	18.11	24.00	24.00	24.00	28.00	28.00	28.00	28.00
Approx. Weight (lbs.)	60	114	208	390	522	1050	1443	1989	2813	3162	4694

Larger sizes are available upon request.

CAST TRUNNION BALL VALVE

MODEL F600/G600, FF600/GG600

Construction: Split body, 2-piece or 3-piece, trunnion mounted ball, Double seal design, double block and bleed, anti-blow out stem, anti-static device, firesafe to API-607/API-6FA, spring loaded seats, designed according to API-6D

Dimensions

Face to Face	API-6D
End Flange	ASME B16.5
Rating	ASME Class 600

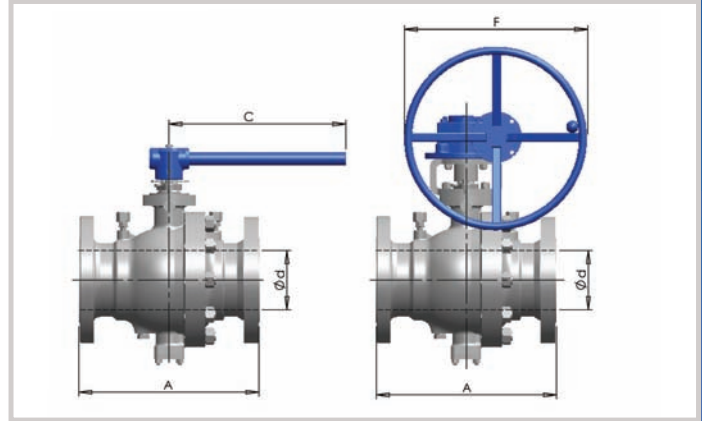

****NACE MR-01-75 Certified****

STANDARD MATERIALS

Figure Number: 2-Piece	F600-1-CC-E2, G600-1-CC-E2	F600-1-BC-E2, G600-1-BC-E2	F600-1-LC-E2, G600-1-LC-E2
Figure Number: 3-Piece	FF600-1-CC-E2, GG600-1-CC-E2	FF600-1-BC-E2, GG600-1-BC-E2	FF600-1-LC-E2, GG600-1-LC-E2
Body/Cap	A216 WCB	A216 WCB	A351 CF8M
Ball	A105N*	A182 F316	A182 F316
Stem	AISI 4140*	A182 F316	A182 F316
Seats & Inserts	ASTM A105N* + Devlon V	A182 F316 + Devlon V	A182 F316 + Devlon V
O-Rings	Viton-B	Viton-B	Viton-B

* Electroless Nickel Plating .001"

Dimensions in inches

CLASS 600 • FULL BORE

Valve Size	2"	3"	4"	6"	8"	10"	12"	14"	16"	18"	20"	24"	
	50mm	80mm	100mm	150mm	200mm	250mm	250mm	350mm	400mm	450mm	500mm	600mm	
Bore Size (d)	2.00	3.00	4.00	6.00	8.00	10.00	12.00	13.25	15.25	17.25	19.25	23.25	
Face to Face (A)	RF	11.50	14.00	17.00	22.00	26.00	31.00	33.00	35.00	39.00	43.00	47.00	55.00
	RTJ	11.63	14.13	17.13	22.13	26.13	31.13	33.13	35.13	39.13	43.13	47.25	55.38
	BWE	11.50	14.00	17.00	22.00	26.00	31.00	33.00	35.00	39.00	43.00	47.00	55.00
Handle Length (C)	19.69	25.39	33.46	-	-	-	-	-	-	-	-	-	
Handwheel Diameter (F)	11.80	18.11	18.11	24.00	24.00	24.00	28.00	28.00	28.00	28.00	30.00	30.00	
Approx. Weight (lbs.)	58	113	179	455	880	1316	2253	2688	3000	4083	4875	8006	

Dimensions in inches

CLASS 600 • REDUCED BORE

Valve Size	3"	4"	6"	8"	10"	12"	14"	16"	18"	20"	24"	
	80mm	100mm	150mm	200mm	250mm	250mm	350mm	400mm	450mm	500mm	600mm	
Bore Size (d)	2.00	3.00	4.00	6.00	8.00	10.00	10.00	12.00	13.25	15.25	19.25	
Face to Face (A)	RF	14.00	17.00	22.00	26.00	31.00	33.00	35.00	39.00	43.00	47.00	55.00
	RTJ	14.13	17.13	22.13	26.13	31.13	33.13	35.13	39.13	43.13	47.25	55.38
	BWE	14.00	17.00	22.00	26.00	31.00	33.00	35.00	39.00	43.00	47.00	55.00
Handle Length (C)	19.69	25.39	33.46	-	-	-	-	-	-	-	-	
Handwheel Diameter (F)	11.80	18.11	18.11	24.00	24.00	24.00	28.00	28.00	28.00	28.00	30.00	
Approx. Weight (lbs.)	70	141	270	510	962	1426	2006	2302	2960	4183	5720	

FORGED TRUNNION BALL VALVE

MODEL FF150/GG150

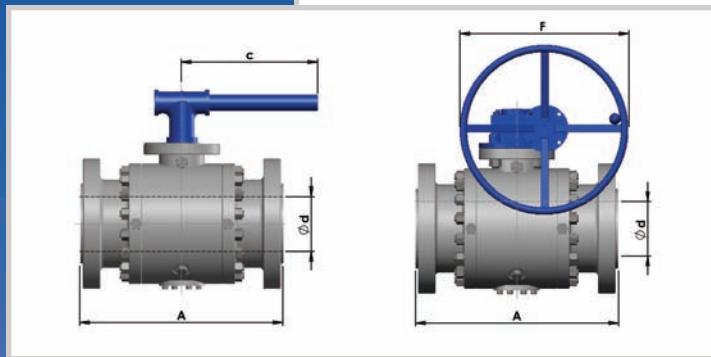

Construction: Three-piece body design, full bore, or reduced bore trunnion mounted ball, double block and bleed, anti-blow out stem, anti-static device, fire-safe to API-607/API-6FA. Spring loaded seats, designed according to API-6D.

Dimensions

Face to Face	API-6D
End Flange	ASME B16.5
Rating	ASME Class 150

****NACE MR-01-75 Certified****

STANDARD MATERIALS

Figure Number	FF150-1-CF-G2, GG150-1-CF-G2	FF150-1-BF-G2, GG150-1-BF-G2	FF150-1-LF-G2, GG150-1-LF-G2
Body/Cap	A105N	A105	A182 F316
Ball	A105N*	A182 F316	A182 F316
Stem	AISI 4140*	A182 F316	A182 F316
Seats & Inserts	ASTM A105N* + RTFE	A182 F316 + RTFE	A182 F316 + RTFE
O-Rings	Viton-B	Viton-B	Viton-B

* Electroless Nickel Plating .003"

CLASS 150 • FULL BORE

Dimensions in inches

Valve Size	2" 50mm	3" 80mm	4" 100mm	6" 150mm	8" 200mm	10" 250mm	12" 250mm	14" 350mm	16" 400mm	18" 450mm	20" 500mm	24" 600mm	30" 750mm	36" 900mm	40" mm	42" mm	48" mm	
Bore Size (d)	2.00	3.00	4.00	6.00	8.00	10.00	12.00	13.25	15.25	17.25	19.25	23.25	29.00	34.50	*	*	*	
Face to Face (A)	RF	7.00	8.00	9.00	15.50	18.00	21.00	24.00	27.00	30.00	34.00	36.00	42.00	51.00	60.00	*	*	*
	BWE	8.50	11.13	12.00	18.00	20.50	22.00	25.00	30.00	33.00	36.00	39.00	45.00	55.00	68.00	*	*	*
Handle Length (C)	14.76	15.55	15.55	25.23	-	-	-	-	-	-	-	-	-	-	*	*	*	
Handwheel Diameter (F)	-	-	18.11	18.11	18.11	24.00	24.00	24.00	24.00	24.00	28.00	28.00	30.00	30.00	*	*	*	
Approx. Weight (lbs.)	62	117	198	359	550	847	1236	1683	2266	3157	3956	6813	11506	19382	*	*	*	

* Available on request.

CLASS 150 • REDUCED BORE

Dimensions in inches

Valve Size	3" 80mm	4" 100mm	6" 150mm	8" 200mm	10" 250mm	12" 250mm	14" 350mm	16" 400mm	18" 450mm	20" 500mm	24" 600mm	30" 750mm	36" 900mm
Bore Size (d)	2.00	3.00	4.00	6.00	8.00	10.00	10.00	12.00	13.25	15.25	19.25	23.25	29.00
Face to Face (A)	RF	8.00	9.00	15.50	18.00	21.00	24.00	27.00	30.00	34.00	36.00	42.00	51.00
	BWE	11.13	12.00	18.00	20.50	22.00	25.00	30.00	33.00	36.00	39.00	45.00	55.00
Handle Length (C)	14.76	15.55	15.55	25.23	-	-	-	-	-	-	-	-	-
Handwheel Diameter (F)	-	-	18.11	18.11	18.11	24.00	24.00	24.00	24.00	24.00	28.00	28.00	30.00
Approx. Weight (lbs.)	68	139	224	414	638	1023	1368	1826	2376	2856	4506	7363	13882

FORGED TRUNNION BALL VALVE

MODEL FF300/GG300

Construction: Three-piece body design, full bore, or reduced bore trunnion mounted ball, double block and bleed, anti-blow out stem, anti-static device, fire-safe to API-607/API-6FA. Spring loaded seats, designed according to API-6D.

Dimensions

Face to Face	API-6D
End Flange	ASME B16.5
Rating	ASME Class 300

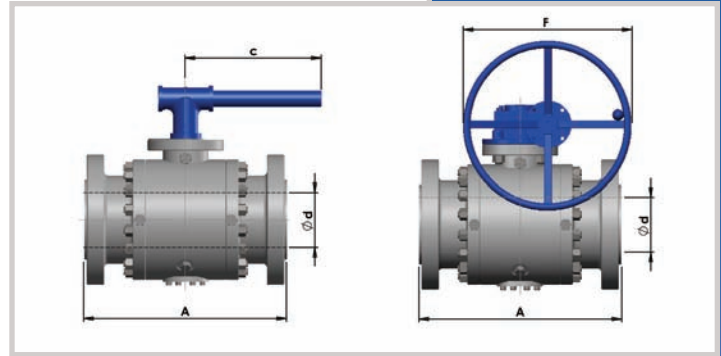

****NACE MR-01-75 Certified****

STANDARD MATERIALS

Figure Number	FF300-1-CF-G2, GG300-1-CF-G2	FF300-1-BF-G2, GG300-1-BF-G2	FF300-1-LF-G2, GG300-1-LF-G2
Body/Cap	A105N	A105N	A182 F316
Ball	A105N*	A182 F316	A182 F316
Stem	AISI 4140*	A182 F316	A182 F316
Seats & Inserts	ASTM A105N* + RTFE	A182 F316 + RTFE	A182 F316 + RTFE
O-Rings	Viton-B	Viton-B	Viton-B

* Electroless Nickel Plating .003"

Dimensions in inches

CLASS 300 • FULL BORE

Valve Size	2"	3"	4"	6"	8"	10"	12"	14"	16"	18"	20"	24"	30"	36"	40"	42"	48"	
	50mm	80mm	100mm	150mm	200mm	250mm	250mm	350mm	400mm	450mm	500mm	600mm	750mm	900mm	mm	mm	mm	
Bore Size (d)	2.00	3.00	4.00	6.00	8.00	10.00	12.00	13.25	15.25	17.25	19.25	23.25	29.00	34.50	*	*	*	
Face to Face (A)	RF	8.50	11.13	12.00	15.88	19.75	22.38	25.50	30.00	33.00	36.00	39.00	45.00	55.00	68.00	*	*	*
	BWE	8.50	11.13	12.00	15.88	20.50	22.00	25.00	30.00	33.00	36.00	39.00	45.00	55.00	68.00	*	*	*
Handle Length (C)	12.40	19.49	21.46	25.23	-	-	-	-	-	-	-	-	-	-	*	*	*	
Handwheel Diameter (F)	-	18.11	18.11	18.11	24.00	24.00	24.00	28.00	28.00	28.00	28.00	30.00	30.00	30.00	*	*	*	
Approx. Weight (lbs.)	64	125	209	407	631	1115	1628	2208	2640	3575	4855	7634	14520	22220	*	*	*	

* Available on request.

Dimensions in inches

CLASS 300 • REDUCED BORE

Valve Size	3"	4"	6"	8"	10"	12"	14"	16"	18"	20"	24"	30"	36"	
	80mm	100mm	150mm	200mm	250mm	250mm	350mm	400mm	450mm	500mm	600mm	750mm	900mm	
Bore Size (d)	2.00	3.00	4.00	6.00	8.00	10.00	10.00	12.00	13.25	15.25	19.25	23.25	29.00	
Face to Face (A)	RF	11.13	12.00	15.88	19.75	22.38	25.50	30.00	33.00	36.00	39.00	45.00	55.00	68.00
	BWE	11.13	12.00	15.88	20.50	22.00	25.00	30.00	33.00	36.00	39.00	45.00	55.00	68.00
Handle Length (C)	12.40	19.49	21.46	25.23	-	-	-	-	-	-	-	-	-	
Handwheel Diameter (F)	-	18.11	18.11	18.11	24.00	24.00	24.00	28.00	28.00	28.00	28.00	30.00	30.00	
Approx. Weight (lbs.)	75	143	260	488	653	1313	1804	2486	3516	3953	5867	9878	18018	

FORGED TRUNNION BALL VALVE

MODEL FF600/GG600

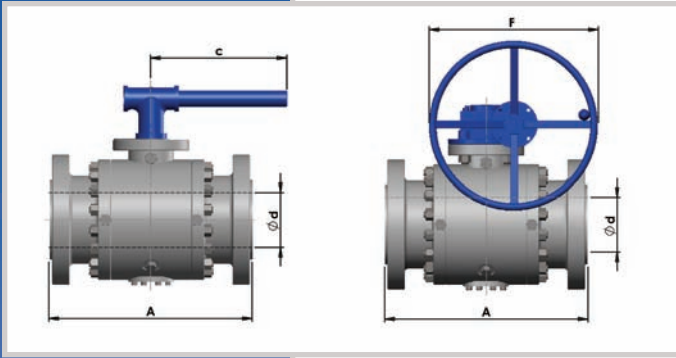

Construction: Three-piece body design, full bore, or reduced bore trunnion mounted ball, double block and bleed, anti-blow out stem, anti-static device, fire-safe to API-607/API-6FA. Spring loaded seats, designed according to API-6D.

Dimensions

Face to Face	API-6D
End Flange	ASME B16.5
Rating	ASME Class 600

STANDARD MATERIALS

****NACE MR-01-75 Certified****

Figure Number	FF600-1-CF-E2, GG600-1-BF-E2	FF600-1-BF-E2, GG600-1-BF-E2	FF600-1-LF-E2, GG600-1-LF-B-E2
Body/Cap	A105N	A105N	A182 F316
Ball	A105N*	A182 F316	A182 F316
Stem	4140*	A182 F316	A182 F316
Seats & Inserts	A105N* + Devlon V	A182 F316 + Devlon V	A182 F316 + Devlon V
O-Rings	Viton-B	Viton-B	Viton-B

* Electroless Nickel Plating .003"

CLASS 600 • FULL BORE

Dimensions in inches

Valve Size	2"	3"	4"	6"	8"	10"	12"	14"	16"	18"	20"	24"	30"	36"	40"	42"	48"	
	50mm	80mm	100mm	150mm	200mm	250mm	250mm	350mm	400mm	450mm	500mm	600mm	750mm	900mm	40"	42"	48"	
															mm	mm	mm	
Bore Size (d)	2.00	3.00	4.00	6.00	8.00	10.00	12.00	13.25	15.25	17.25	19.25	23.25	29.00	34.50	*	*	*	
Face to Face (A)	RF	11.50	14.00	17.00	22.00	26.00	31.00	33.00	35.00	39.00	43.00	47.00	55.00	65.00	82.00	*	*	*
	RTJ	11.63	14.13	17.13	22.13	26.13	31.13	33.13	35.13	39.13	43.13	47.25	55.38	65.50	82.63	*	*	*
	BWE	11.50	14.00	17.00	22.00	26.00	31.00	33.00	35.00	39.00	43.00	47.00	55.00	65.00	82.00	*	*	*
Handle Length (C)	19.69	25.39	33.46	-	-	-	-	-	-	-	-	-	-	-	*	*	*	
Handwheel Diameter (F)	11.80	18.11	18.11	24.00	24.00	24.00	28.00	28.00	28.00	28.00	30.00	30.00	30.00	30.00	*	*	*	
Approx. Weight (lbs.)	73	141	224	569	1100	1645	2816	3360	3750	5104	6094	10008	16000	29260	*	*	*	

* Available on request.

CLASS 600 • REDUCED BORE

Dimensions in inches

Valve Size	3"	4"	6"	8"	10"	12"	14"	16"	18"	20"	24"	30"	36"
	80mm	100mm	150mm	200mm	250mm	250mm	350mm	400mm	450mm	500mm	600mm	750mm	900mm
Bore Size (d)	2.00	3.00	4.00	6.00	8.00	10.00	10.00	12.00	13.25	15.25	19.25	23.25	29.00
Face to Face (A)	RF	14.00	17.00	22.00	26.00	31.00	33.00	35.00	39.00	43.00	47.00	55.00	82.00
	RTJ	14.13	17.13	22.13	26.13	31.13	33.13	35.13	39.13	43.13	47.25	55.38	82.63
	BWE	14.00	17.00	22.00	26.00	31.00	33.00	35.00	39.00	43.00	47.00	55.00	82.00
Handle Length (C)	19.69	25.39	33.46	-	-	-	-	-	-	-	-	-	-
Handwheel Diameter (F)	11.80	18.11	18.11	24.00	24.00	24.00	28.00	28.00	28.00	28.00	30.00	30.00	30.00
Approx. Weight (lbs.)	88	176	337	638	1203	1782	2508	2878	3700	5229	7150	12694	22836

FORGED TRUNNION BALL VALVE

MODEL FF900/GG900

Construction: Three-piece body design, full bore, or reduced bore trunnion mounted ball, double block and bleed, anti-blow out stem, anti-static device, fire-safe to API-607/API-6FA. Spring loaded seats, designed according to API-6D.

Dimensions

Face to Face	API-6D
End Flange	ASME B16.5
Rating	ASME Class 900

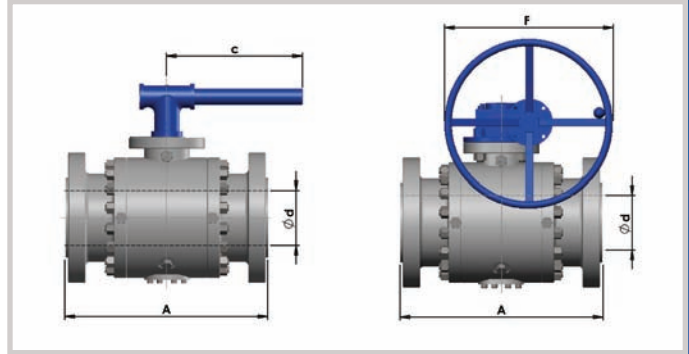

****NACE MR-01-75 Certified****

STANDARD MATERIALS

Figure Number	FF900-1-CF-E2, GG900-1-CF-E2	FF900-1-BF-E2, GG900-1-BF-E2	FF900-1-LF-E2, GG900-1-LF-E2
Body/Cap	A105N	A105N	A182 F316
Ball	A105N*	A182 F316	A182 F316
Stem	AISI 4140*	17-4PH	17-4PH
Seats & Inserts	A105N* + Devlon V	A182 F316 + Devlon V	A182 F316 + Devlon V
O-Rings	Viton-B	Viton-B	Viton-B

* Electroless Nickel Plating .003"

Dimensions in inches

CLASS 900 • FULL BORE

Valve Size	2"	3"	4"	6"	8"	10"	12"	14"	16"	18"	20"	24"	30"	36"	
	50mm	80mm	100mm	150mm	200mm	250mm	250mm	350mm	400mm	450mm	500mm	600mm	750mm	900mm	
Bore Size (d)	2.00	3.00	4.00	6.00	8.00	10.00	12.00	12.75	14.75	16.75	18.63	22.50	28.11	*	
Face to Face (A)	RF	14.50	15.00	18.00	24.00	29.00	33.00	38.00	40.50	44.50	48.00	52.00	61.00	70.08	*
	RTJ	14.63	15.13	18.13	24.13	29.13	33.13	38.13	40.88	44.88	48.50	52.50	61.75	*	
	BWE	14.50	15.00	18.00	24.00	29.00	33.00	38.00	40.50	44.50	48.00	52.00	61.00	70.08	*
Handle Length (C)	18.10	21.38	36.00	-	-	-	-	-	-	-	-	-	-	*	
Handwheel Diameter (F)	-	18.11	18.11	24.00	24.00	28.00	28.00	30.00	30.00	30.00	30.00	30.00		*	
Approx. Weight (lbs.)	125	167	409	913	1320	1936	3428	3249	4972	6292	9284	15070	26862	*	

* Available on request.

Dimensions in inches

CLASS 900 • REDUCED BORE

Valve Size	3"	4"	6"	8"	10"	12"	14"	16"	18"	20"	24"	30"	36"	
	80mm	100mm	150mm	200mm	250mm	250mm	350mm	400mm	450mm	500mm	600mm	750mm	900mm	
Bore Size (d)	2.00	3.00	4.00	6.00	8.00	10.00	10.00	12.00	13.25	15.25	19.25	*	*	
Face to Face (A)	RF	15.00	18.00	24.00	29.00	33.00	38.00	40.50	44.50	48.00	52.00	61.00	*	*
	RTJ	15.13	18.13	24.13	29.13	33.13	38.13	40.88	44.88	48.50	52.50	61.75	*	*
	BWE	15.00	18.00	24.00	29.00	33.00	38.00	40.50	44.50	48.00	52.00	61.00	*	*
Handle Length (C)	18.11	21.38	36.00	-	-	-	-	-	-	-	-	*	*	
Handwheel Diameter (F)	-	18.11	18.11	24.00	24.00	24.00	28.00	28.00	30.00	30.00	30.00	*	*	
Approx. Weight (lbs.)	117	213	462	983	1540	2526	3615	3777	5361	6351	11880	*	*	

FORGED TRUNNION BALL VALVE

MODEL FF1500/GG1500

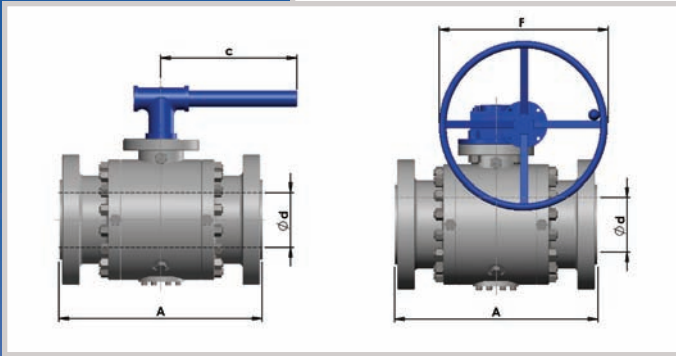

Construction: Three-piece body design, full bore, or reduced bore trunnion mounted ball, double block and bleed, anti-blow out stem, anti-static device, fire-safe to API-607/API-6FA. Spring loaded seats, designed according to API-6D.

Dimensions

Face to Face	API-6D
End Flange	ASME B16.5
Rating	ASME Class 1500

STANDARD MATERIALS

****NACE MR-01-75 Certified****

Figure Number	FF1500-1-CF-E2, GG1500-1-CF-E2	FF1500-1-BF-E2, GG1500-1-BF-E2	FF1500-1-LF-E2, GG1500-1-LF-E2
Body/Cap	A105N	A105N	A182 F316
Ball	A105N*	A182 F316	A182 F316
Stem	AISI 4140*	17-4PH	17-4PH
Seats & Inserts	A105N* + Devlon V	A182 F316 + Devlon V	A182 F316 + Devlon V
O-Rings	Viton-B	Viton-B	Viton-B

* Electroless Nickel Plating .003"

CLASS 1500 • FULL BORE

Dimensions in inches

Valve Size	2" 50mm	3" 80mm	4" 100mm	6" 150mm	8" 200mm	10" 250mm	12" 250mm	14" 350mm	16" 400mm	18" 450mm	20" 500mm	24" 600mm	
Bore Size (d)	2.00	3.00	4.00	5.75	7.63	9.50	11.38	12.50	14.25	16.00	17.75	21.00	
Face to Face (A)	RF	14.50	18.50	21.50	27.75	32.75	39.00	44.50	49.50	54.50	60.50	65.50	80.50
	RTJ	14.63	18.60	21.60	28.00	33.10	39.40	45.10	50.23	55.35	61.38	66.38	81.54
	BWE	14.50	18.50	21.50	27.75	32.75	39.00	44.50	49.50	54.50	60.50	65.50	80.50
Handle Length (C)	28.00	-	-	-	-	-	-	-	-	-	-	-	
Handwheel Diameter (F)	18.11	18.11	24.00	24.00	28.00	28.00	28.00	30.00	30.00	30.00	30.00	30.00	
Approx. Weight (lbs.)	173	303	447	1067	1628	3315	4998	6336	9064	13772	20064	31504	

CLASS 1500 • REDUCED BORE

Dimensions in inches

Valve Size	3" 80mm	4" 100mm	6" 150mm	8" 200mm	10" 250mm	12" 250mm	14" 350mm	16" 400mm	18" 450mm	20" 500mm	24" 600mm	
Bore Size (d)	2.00	3.00	4.00	5.75	7.63	9.50	9.50	11.38	12.5	14.26	17.75	
Face to Face (A)	RF	18.50	21.50	27.75	32.75	39.00	44.50	49.50	54.50	60.50	65.50	80.50
	RTJ	18.60	21.60	28.00	33.10	39.40	45.10	50.23	55.35	61.38	66.38	81.54
	BWE	18.50	21.5	27.75	32.75	39.00	44.50	49.50	54.50	60.50	65.50	80.50
Handle Length (C)	28.00	-	-	-	-	-	-	-	-	-	-	
Handwheel Diameter (F)	18.11	18.11	24.00	24.00	28.00	30.00	30.00	30.00	30.00	30.00	30.00	
Approx. Weight (lbs.)	205	335	763	1188	2270	3887	5581	7216	10956	16588	24090	

FORGED TRUNNION BALL VALVE

MODEL FF2500/GG2500

Construction: Three-piece body design, full bore, or reduced bore trunnion mounted ball, double block and bleed, anti-blow out stem, anti-static device, fire-safe to API-607/API-6FA. Spring loaded seats, designed according to API-6D.

Dimensions

Face to Face	API-6D
End Flange	ASME B16.5
Rating	ASME Class 2500

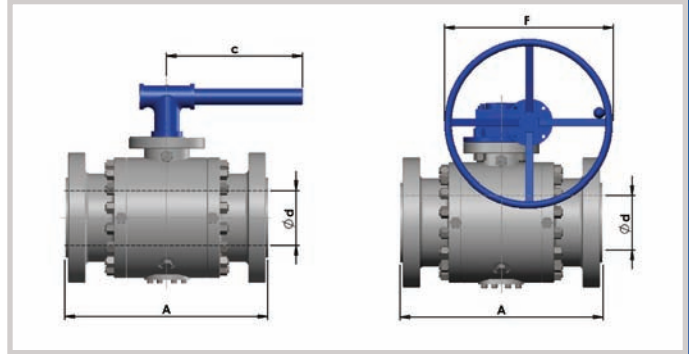

****NACE MR-01-75 Certified****

STANDARD MATERIALS

Figure Number	FF2500-1-CF-E2, GG2500-1-CF-E2	FF2500-1-BF-E2, GG2500-1-BF-E2	FF2500-1-LF-E2, GG2500-1-LF-E2
Body/Cap	A105N	A105N	A182 F316
Ball	A105N*	A182 F316	A182 F316
Stem	17-4 PH	17-4 PH	17-4 PH
Seats & Inserts	A105N* + Devlon V	A182 F316 + Devlon V	A182 F316 + Devlon V
O-Rings	Viton-B	Viton-B	Viton-B

* Electroless Nickel Plating .003"

Dimensions in inches

CLASS 2500 • FULL BORE

Valve Size	2" 50mm	3" 80mm	4" 100mm	6" 150mm	8" 200mm	10" 250mm	12" 250mm
Bore Size (d)	1.65	2.44	3.43	5.16	7.05	8.78	10.43
Face to Face (A)	RF	17.76	22.76	26.50	35.98	40.24	50.00
	RTJ	17.87	22.99	26.89	36.50	40.82	50.87
	BWE	17.76	27.76	26.50	35.98	40.24	50.00
Handle Length (C)	-	-	-	-	-	-	-
Handwheel Diameter (F)	18.11	24.00	24.00	24.00	30.00	30.00	30.00
Approx. Weight (lbs.)	390	620	866	1518	2974	4994	7187

Dimensions in inches

CLASS 2500 • REDUCED BORE

Valve Size	3" 80mm	4" 100mm	6" 150mm	8" 200mm	10" 250mm	12" 250mm
Bore Size (d)	2.05	2.44	3.43	5.16	7.05	8.78
Face to Face (A)	RF	22.76	26.50	35.98	40.24	50.00
	RTJ	22.99	26.89	36.50	40.87	50.87
	BWE	22.76	26.50	35.98	40.24	50.00
Handle Length (C)	-	-	-	-	-	-
Handwheel Diameter (F)	18.11	24.00	24.00	24.00	30.00	30.00
Approx. Weight (lbs.)	400	601	1357	2416	3667	5647

FORGED TRUNNION BALL VALVE

MODEL FF3009/GG3009

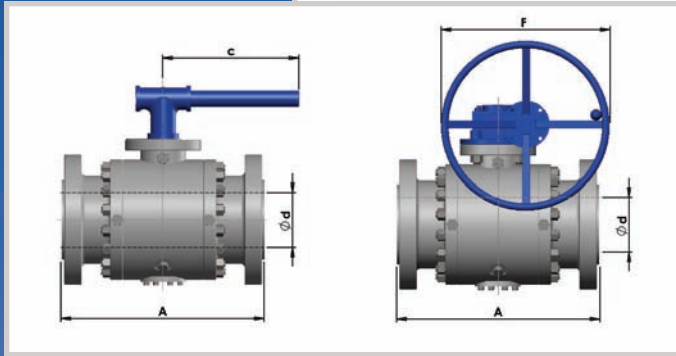

Construction: Three-piece body design, full bore, or reduced bore trunnion mounted ball, double block and bleed, anti-blow out stem, anti-static device, fire-safe to API-607/API-6FA. Spring loaded seats, designed according to API-6D.

Dimensions

Face to Face	API-6A
End Flange	API-6A
Rating	API 3000

****NACE MR-01-75 Certified****

STANDARD MATERIALS

Figure Number	FF3009-1-CF-E2, GG3009-1-CF-E2	FF3009-1-BF-E2, GG3009-1-BF-E2	FF3009-1-LF-E2, GG3009-1-BF-E2
Body/Cap	A105N	A105N	A182 F316
Ball	A105N*	A182 F316	A182 F316
Stem	17-4 PH	17-4 PH	17-4 PH
Seats & Inserts	A105N* + Devlon V	A182 F316 + Devlon V	A182 F316 + Devlon V
O-Rings	Viton-B	Viton-B	Viton-B

* Electroless Nickel Plating .003"

API 3000 • FULL BORE

Dimensions in inches

Valve Size	2-1/16" 51.6mm	3-1/8" 78.13mm	4-1/16" 101.6mm	5-1/8" 128.1mm	7-1/16" 176.6mm
Bore Size (d)	2.06	3.12	4.06	5.12	7.06
Face to Face (A)	RTJ 14.61	17.13	20.12	24.13	28.11
Handle Length (C)	30.00	36.00	-	-	-
Handwheel Diameter (F)	-	-	17.00	20.00	24.00
Approx. Weight (Lbs.)	110	190	350	550	950

API 3000 • REDUCED BORE

Dimensions in inches

Valve Size	2-1/16" 51.6mm	3-1/8" 78.13mm	4-1/16" 101.6mm	7-1/16" 176.6mm
Bore Size (d)	1.81	2.06	3.12	5.12
Face to Face (A)	RTJ 14.61	17.13	20.12	24.13
Handle Length (C)	30.00	36.00	-	-
Handwheel Diameter (F)	-	-	17.00	20.00
Approx. Weight (Lbs.)	110	190	350	750

FORGED TRUNNION BALL VALVE

MODEL FF5009/GG5009

Construction: Three-piece body design, full bore, or reduced bore trunnion mounted ball, double block and bleed, anti-blow out stem, anti-static device, fire-safe to API-607/API-6FA. Spring loaded seats, designed according to API-6D.

Dimensions

Face to Face	API-6A
End Flange	API-6A
Rating	API 5000

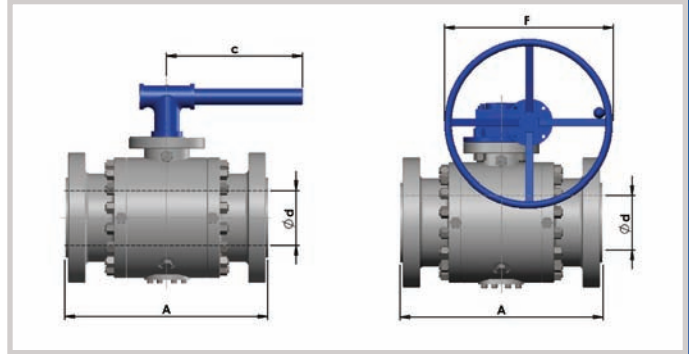

****NACE MR-01-75 Certified****

STANDARD MATERIALS

Figure Number	FF5009-1-CF-E2, GG5009-1-CF-E2	FF5009-1-BF-E2, GG5009-1-BF-E2	FF5009-1-LF-E2, GG5009-1-LF-E2
Body/Cap	A105N	A105N	A182 F316
Ball	A105N*	A182 F316	A182 F316
Stem	17-4 PH	17-4 PH	17-4 PH
Seats & Inserts	A105N* + Devlon V	A182 F316 + Devlon V	A182 F316 + Devlon V
O-Rings	Viton-B	Viton-B	Viton-B

* Electroless Nickel Plating .003"

Dimensions in inches

API 5000 • FULL BORE

Valve Size	2-1/16" 51.6mm	3-1/8" 78.13mm	4-1/16" 101.6mm	5-1/8" 128.1mm	7-1/16" 176.6mm
Bore Size (d)	2.06	3.12	4.06	5.12	7.06
Face to Face (A)	RTJ 14.61	18.62	21.61	28.62	32.01
Handle Length (C)	30.00	-	-	-	-
Handwheel Diameter (F)	-	17.00	20.00	20.00	24.00
Approx. Weight (Lbs.)	110	240	420	805	1,360

Dimensions in inches

API 5000 • REDUCED BORE

Valve Size	2-1/16" 51.6mm	3-1/8" 78.13mm	4-1/16" 101.6mm	7-1/16" 176.6mm
Bore Size (d)	1.81	2.06	3.12	5.12
Face to Face (A)	RTJ 14.61	18.62	21.61	32.01
Handle Length (C)	30.00	-	-	-
Handwheel Diameter (F)	-	17.00	20.00	24.00
Approx. Weight (Lbs.)	110	240	420	1,190

PRESSURE/TEMPERATURE CHART

MODEL F, FF, G & GG TRUNNION BALL VALVE

The following chart indicates the pressure and temperature ratings for commonly used seat insert plastic and elastomer seal material used in GWC trunnion mounted ball valves. Other materials are available upon request.

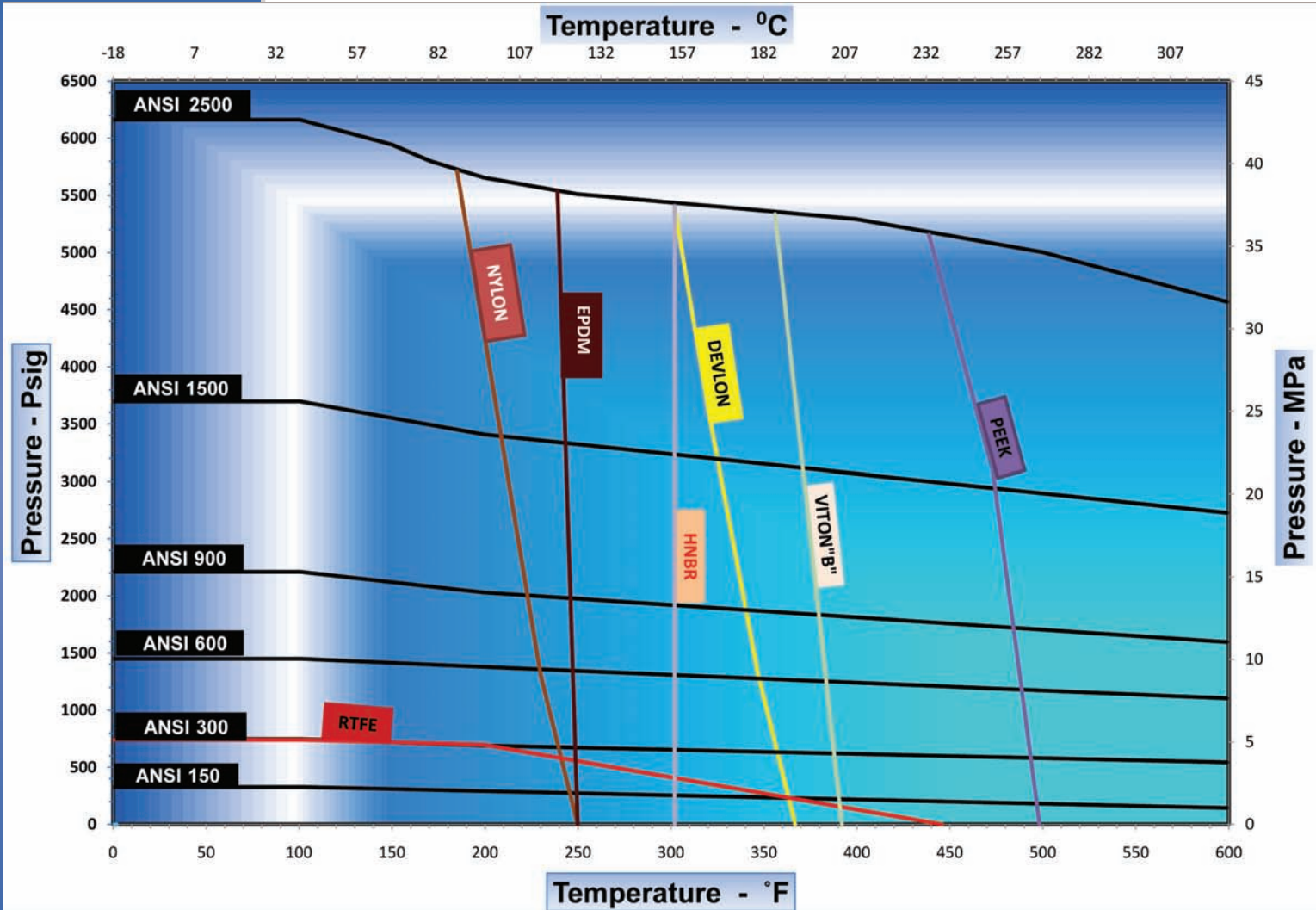

Scope

These terms and conditions apply to all GWC valve products, and supersedes all previously published terms and conditions.

Hereafter, GWC Valve International, Inc. shall be referred to as GWC.

Special terms and conditions printed on a buyer's order will only apply insofar as they conform to the terms and conditions detailed on these pages. Terms and conditions of an order that change or modify those on this sheet shall not be binding on GWC.

Approval

All quotations, contracts, orders, or agreements are subject to approval and/or acceptance by the main office of GWC.

We reserve the right to correct clerical or stenographic errors in quotations, orders, invoices, and other contracts, agreements, or documents.

Prices

Possession of price lists will not be accepted by GWC as an obligation, or offer to sell the goods listed therein to anyone.

All prices contained therein are subject to change without notice, and supersede all previous lists. All orders will be invoiced at prices in effect at the time of shipment unless quoted in writing.

Changes

Orders cannot be cancelled or specifications be changed without the consent of GWC, and then only in terms indemnifying GWC against loss.

Quotations

Goods quoted F.O.B. our service center are subject to prior sale. Prices quoted are valid only for the duration indicated in the quotation. Quoted prices supersede all previous prices, quotations, or contracts, and are subject to change without notice.

Cancellations

Orders placed with us cannot be cancelled without our prior written consent. A cancellation charge will be applicable as outlined in our quotation.

Claims

All claims for shortages, corrections, or deductions must be made within 10 days after receipt of goods. Responsibility for goods lost or damaged in transit rests with carrier, and claims should be filed with the carrier by the consignee. Delivery of material to a common carrier shall be considered delivery to the buyer, and shall be at the buyers risk thereafter.

Delivery Delays

We assume no responsibility for delays in delivery, or defaults resulting from strikes, work stoppages, fires, floods, accidents, war, inability to obtain materials, or any other cause unavoidable and beyond our control.

Taxes

GWC quotations and/or contracts do not include any municipal, state, or federal sales, excise, use occupational, or other taxes, and any such tax, if paid by us will be charged to the purchaser.

Catalog Illustrations

Catalog illustrations are actual representations of a certain size of each product line, but do not necessarily represent all sizes in details. We reserve the right to institute changes in materials, designs, and specifications without notice in keeping with our policy of continuing product improvement.

Catalog Weights

Catalog weights represent average weights of products and are in no sense guaranteed.

Returns

See Return Goods Policy on next page.

Special Orders

Orders for special goods must be in writing and accompanied with detailed prints and/or sets of specifications, unless specifications on the orders are definite and complete. Orders will not be entered with the factory unless this is adhered to. Cancellation charges will be as outlined in our quotations.

Freight Terms

All shipments are F.O.B. our service centers. See current bulletin for freight allowance.

Warranty

See warranty on reverse side

RETURN GOODS POLICY

This policy supersedes all other policies for return goods.

- I. Goods returned at customers request:
 - A. Material must be:
 1. Of our manufacture.
 2. In clean, new and saleable condition. It must have been stored inside out of the weather.
 3. Shipped from one of our service centers within the 12 calendar months preceding the request for return, and the return will not cause inventory to exceed maximum allowable levels.
 4. Personally inspected by a GWC representative prior to its return.
 5. Special or non-standard items are non-returnable.
 - B. Return shipments must be prepaid.
 - C. Credit will be allowed at invoice price, less 25% handling cost, and less any freight paid by GWC.
 - D. A Return Goods Card must be furnished by a GWC representative after inspection of the material, and must be returned with the shipment.
 - E. Shipments received without a Return Goods Authorization Card will be refused. Customer will be responsible for any storage and/or return freight.
 - F. Material returned which is not of GWC manufacture, not in clean and saleable condition, or not authorized for return will be returned to the customer freight collect.
- II. Goods returned because of an error by GWC.
 - A. Material must be in a clean, new, saleable condition.
 - B. Return shipment should be made freight collect.
 - C. Full credit will be allowed.
 - D. Customer must receive Return Goods authorization prior to the return of the material. Return Goods Authorization Card must accompany shipment. Shipments received without Return Goods Authorization Card will be refused. Return Goods Authorization Card should be attached to the packing list.

All requests to return material to GWC Valve International, Inc. must be submitted in writing to our National Sales Manager for authorization.

WARRANTY

GWC Valve International, Inc. warrants each product sold, if the products are of our manufacture, against defects in material and workmanship under normal use and service for a period of one year after date of shipment.

This warranty is made to the buyer only, and does not extend to any other party. The obligation of GWC Valve International, Inc. under this warranty is limited to: (a) replacement of any part or parts proven defective in material or workmanship, (b) repair of the product F.O.B. the factory or service center, (c) refund of the purchase price. In the case of product or parts not wholly of GWC's manufacture, GWC's liability under this warranty shall be limited to the extent of GWC's recovery from the manufacturer of such parts under its warranty to GWC. This warranty does not extend to any claims for labor, consequential damages, down time, or any other loss, damage, or expense of any kind arising out of the defect. We do not allow claims for unauthorized repairs, labor, or material. We are not responsible for loss of use, personal injury, lost profits, or any other damages whatsoever in connection with the warranties set forth.

No warranty shall apply to any product which has been modified or changed in design or function after leaving GWC's facilities or which is misused or operated beyond its design capabilities, or used for other than its intended purpose. Purchasers of GWC products should consult knowledgeable advisors in the selection of product type and material of construction for their specific use. The buyer assumes all risk of this selection.

The buyer shall permit GWC or its authorized representative to inspect the product so that it may determine its obligation. GWC shall be entitled to the return of the defective product or parts. Buyer must notify GWC promptly upon discover of any claimed defect.

No material may be returned without first obtaining written permission from GWC Valve International, Inc.



USA HEADQUARTERS

GWC Valve International, Inc.

4301 Yeager Way

Bakersfield, CA 93313

Ph: 1-661-834-1775

Fax: 1-661-834-2072

E-Mail: Sales@GWCvalve.com

WWW.GWCValve.com

