

 **PVCPIPE**
association

FIFTH EDITION

Handbook of
PVC
Pipe Design
and
Construction



 **PVCPIPE**
association

FIFTH EDITION
Handbook of

PVC

Pipe Design
and
Construction





CHAPTER 12

**PVC Nonpressure
Pipe Installation**



Trench Construction

•

Pipe Laying

•

System Components

•

**Inspection and Testing
of the Pipe System**

Table of Contents

12.1 Notation.....	12.3
12.2 Introduction.....	12.3
12.3 Trench Construction.....	12.4
12.3.1 Minimum Trench Width.....	12.4
12.3.2 Movable Sheet piling, Trench Boxes, or Shields.....	12.6
12.3.3 Dewatering.....	12.7
12.3.4 Preparation of Trench Bottom.....	12.8
12.4 Pipe Laying.....	12.9
12.4.1 Bedding.....	12.10
12.4.2 Haunching.....	12.10
12.4.3 Initial Backfill.....	12.10
12.4.4 Final Backfill.....	12.11
12.4.5 Embedment Materials.....	12.13
12.4.5.1 Class I Materials.....	12.13
12.4.5.2 Class II Materials.....	12.13
12.4.5.3 Class III Materials.....	12.13
12.4.5.4 Class IV Materials.....	12.16
12.4.6 Migration.....	12.16
12.4.7 Embedment Compaction.....	12.17
12.4.8 Common Trenches.....	12.18
12.4.9 Sewers on Steep Slopes.....	12.19
12.4.10 Recommended Embedment Densities.....	12.19
12.5 System Components.....	12.20
12.5.1 Fittings.....	12.20
12.5.2 Service Lines.....	12.21

12.5.3 Pipe Caps and Plugs.....	12.22
12.5.4 Risers.....	12.23
12.5.5 Manholes and Junctions.....	12.24
12.6 Inspection and Testing of the Pipe System.....	12.29
12.6.1 Precleaning.....	12.29
12.6.2 Visual Inspection.....	12.29
12.6.3 Leakage Testing.....	12.30
12.6.3.1 Air Testing.....	12.30
12.6.3.2 Infiltration/Exfiltration Testing.....	12.30
12.6.4 Deflection Testing.....	12.30
12.7 Sources.....	12.35

12.1 Notation

A = OD tolerance (ASTM D3034 or F679), in.

B = excess wall thickness tolerance = $0.06t$, in.

C = out-of-roundness tolerance (ASTM D3034 or F679), in.

DR = dimension ratio, dimensionless

ID_{avg} = pipe average inside diameter, in.

ID_{base} = pipe base inside diameter, in.

OD_{avg} = pipe average outside diameter, in.

t = minimum wall thickness (ASTM D3034 or F679), in.

12.2 Introduction

The importance of proper construction practices for any piping system cannot be overstated. A functional PVC *nonpressure* piping system depends on its raw materials, the research and development behind the technology, product specifications, manufacturing, quality control, design, and proper installation.

Recommended practices for nonpressure sewer pipe installation are presented in the following categories:

- trench construction
- pipe laying
- appurtenances
- inspection and testing of the pipe system.

12.3 Trench Construction

Excavation for pipe installation is minimal, being just enough to allow the trench to be safely maintained by available equipment and so trench sides will be stable under all working conditions. Furthermore, trench walls should be sloped or supported in conformance with all safety codes. Trenches should be backfilled as soon as is practical (but no later than the end of each workday). Other trench construction best practices are as follows:

- Trenches should be excavated to the alignment and elevations indicated on drawings; any deviations should be approved by the piping system design engineer.
- Appurtenances should be located and installed in accordance with design requirements.
- Excavated material should be stockpiled in a manner that will not endanger the workers.
- Hydrants, water and gas valves, manhole covers, and other utilities should be left unobstructed and accessible until work is completed.
- Gutters should be kept open or other satisfactory provisions made for street drainage.
- Unless otherwise approved, stockpiles should not obstruct adjacent streets, walks, or driveways.
- If excavated material is to be used for backfill, it should be easily accessible.

12.3.1 Minimum Trench Width

Where trench walls are stable (i.e., do not need supports) trench width should be sufficient for the safe placement and compaction of haunching. The space between pipe and trench wall must be wider than the compaction equipment used in the pipe zone. Minimum width recommendations are:

- 18 in. (450 mm) for 4- and 6-in. (100- and 150-mm) pipe sizes
- No less than 12 to 18 in. (300 to 450 mm) greater than the pipe OD for 8-in. (200-mm) and larger sizes
- Resulting minimum trench widths are given in Table 12.1.

PVC Nonpressure Pipe Installation

Table 12.1 Narrow trench width, minimum

Pipe diam.		No. of pipe diam. of trench	Trench width	
in.	mm		in.	mm
4	100	4.3	18	460
6	150	2.9	18	460
8	200	2.9	24	610
10	250	2.5	26	660
12	300	2.4	30	760
15	375	2.0	30	760
18	450	1.8	32	810
21	525	1.6	34	860
24	600	1.5	36	920
27	675	1.5	40	1,020
30	750	1.4	42	1,070
33	825	1.4	45	1,140
36	900	1.4	48	1,220
42	1,050	1.4	54	1,370
48	1,200	1.3	60	1,530
54	1,350	1.2	66	1,680
60	1,500	1.2	72	1,830

Note: Minimum trench widths are intended to provide adequate spacing between pipe and trench wall for proper placing and compaction of haunching material; minimum widths may vary somewhat, depending on construction procedures used.

The minimum trench widths shown in Table 12.1 are based on the use of free-flowing granular materials (Classes I and II in Table 12.2). These materials can often be adequately compacted by nothing more than shovel-slicing and modest effort.

In places where trench walls must be supported:

- minimum widths are measured to the inside of the support structure;
- compaction of the foundation and embedment materials should extend to the trench walls, or sheeting should be left in place.

In addition to safety considerations, minimum trench widths in unsupported, unstable soils will depend on size and stiffness of pipe, stiffness of embedment and in-situ soil,

and depth of cover. In some cases, where in-situ lateral soil resistance is negligible such as in very poor native soils (for example, peat, muck, or highly expansive soils), wide trenches may be more economical than a trench-support system. Under these conditions, a minimum width of embedment material is required to ensure that adequate embedment stiffness is developed to support the pipe without assistance from the sidewalls. Per ASTM D2321, if the native soil cannot sustain a vertical cut or if it is an embankment situation, the recommended minimum embedment width should be one pipe diameter on both sides of the pipe. Embedment materials should be Class II granular material or Class I crushed rock. Installation of embedment materials around the pipe should follow ASTM D2321 guidelines.

In either stable or unstable soil conditions, where wide trench construction is required a variation of vertical minimum trench width is to lay the pipe in a subditch and backcut or slope the sides of the excavation above the pipe, as shown in Figs. 12.1 and 12.2. This type of construction may be permitted where no inconvenience to the public or damage to property, buildings, subsurface structures, or pavement will result. In such a case, the width of the subditch below the top of the pipe should coincide with the values in Table 12.1.

12.3.2 Movable Sheeting, Trench Boxes, or Shields

When movable trench support is used, care should be taken to prevent disturbing the pipe location, jointing and embedment. Removal of any trench protection below the top of the pipe and within the dimensions outlined in Table 12.1 for wide trench installations should be prohibited after pipe embedment has been compacted. For this reason, movable trench supports should be used only in wide trench construction, where supports extend below the top of the pipe, or on a shelf above the pipe (with the pipe installed in a narrow, vertical-wall subditch). Any voids left in the embedment material as a result of trench protection removal should be carefully filled with granular material that is adequately compacted. Removal of bracing between sheeting should be done only where backfilling proceeds and where bracing can be removed in a manner that does not relax trench support. When trench boxes or shields are advanced, care should be taken to prevent longitudinal pipe movement or disjoints.

In instances where a trench support must extend to the bottom of a ditch, where a subditch is impractical, or where native soils are unstable, a simple alteration to the commonly used trench box may be the best alternative. A section one-half the length of the box, with a depth of approximately 2 ft cut from the bottom of the box (see Fig. 12.3) will allow the trench shield to ride on the bottom of a narrow trench, while allowing undisturbed pipe embedment to sit in the back half. As the trench box is moved forward, embedment may be compacted all the way to the trench wall.



Trench safety is especially important in deep installations.

Fig. 12.1 Deep installation.

12.3.3 Dewatering

Where running or standing water occurs in the trench bottom, or the soil in the trench bottom displays a “quick” tendency, the water should be removed by pumps and other suitable means such as well points or pervious underdrain bedding to prevent pipe flotation, until the pipe has been installed and the backfill has been placed to a sufficient height.

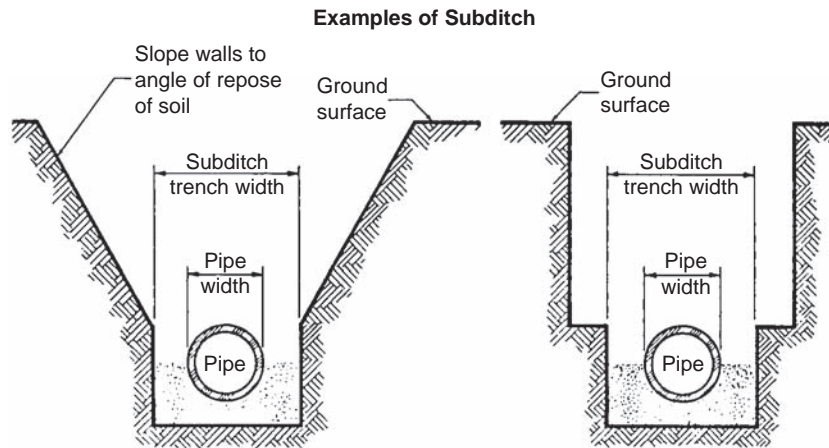

Fig. 12.2 Subditch examples.



Fig. 12.3 Trench box schematic.

Care should be taken that any underdrain is of proper gradation and thickness to prevent migration of material between the underdrain, pipe embedment, and native soils in the trench below and at the sides of the pipe.

12.3.4 Preparation of Trench Bottom

The trench bottom should be constructed to provide a firm, stable, and uniform support for the full length of the pipe. Bell holes should be provided at each joint to permit proper joint assembly and alignment. Any part of the trench bottom excavated below grade should be backfilled to grade and compacted as required to provide firm foundation. When unstable subgrade conditions that will not provide adequate pipe support are encountered, additional trench depth should be excavated and the space refilled with suitable foundation material as specified by the design engineer. In severe conditions, special foundations may be required to maintain grade, as specified by the design engineer. A cushion of

acceptable bedding material should always be provided between any hard foundation and the pipe. Ledge rock, boulders, and large stones should be removed to provide at least 4 in. (100 mm) of soil cushion on all sides of a pipe and accessories.

12.4 Pipe Laying

To prevent pipe damage, proper implements, tools, and equipment should be used for placement of the pipe in the trench; pipe and/or accessories should never be dropped into the trench. Pipe laying should generally commence at the lowest elevation and terminate at man-holes, service branches, or clean-outs. Pipe bells can be laid either upstream or downstream. However, common practice is to lay them in the direction of work progress. Insertion of the spigot into the bell (rather than pushing of the bell over spigot) reduces the risk of soil or rubble being scooped under the gasket. Whenever pipe laying is interrupted, the open ends of installed pipe should be closed to prevent entrance of trench water, mud, and foreign matter.

Figure 12.4 shows the embedment zones described in Sections 12.4.1 through 12.4.4.

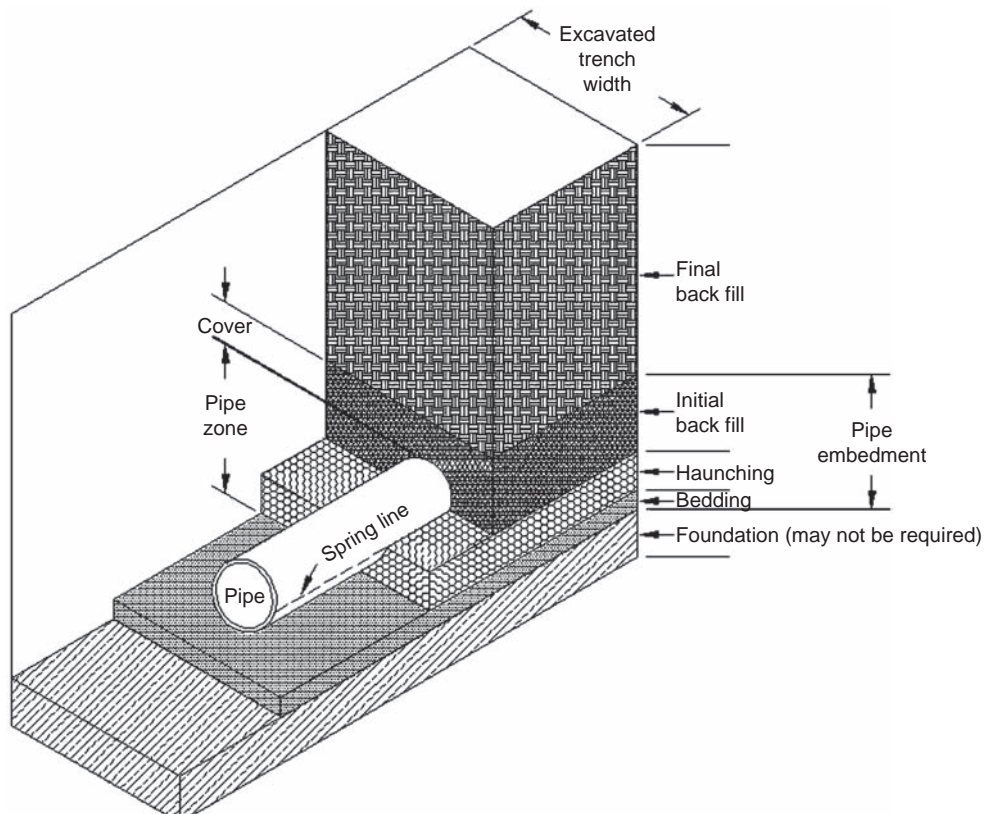

Fig. 12.4 Embedment zones of trench ditch.

12.4.1 Bedding

Bedding is primarily required to bring the trench bottom up to grade; it should be placed so as to provide uniform and adequate support under the pipe (Fig. 12.4). (Blocking should not be used.) Bell holes at each joint provide for proper assembly of the pipe while uniform pipe support is maintained. A depth of 4 to 6 in. (100 to 150 mm) is generally sufficient for bedding thickness. In trenches with natural materials of fine grains and in conditions where migration of trench wall material into bedding material can be anticipated, either wide trench construction or well-graded bedding material without voids should be used.

12.4.2 Haunching

The factor that most affects pipe performance and deflection is haunching material and density. Material should be placed and consolidated under the pipe haunch (Fig. 12.4) so adequate side support is provided to the pipe without causing displacement from its proper alignment (either vertical or horizontal). Where coarse materials with voids have been used for bedding, the same coarse material should also be used for haunching; consideration should be given to native soil migration. Haunching is placed up to the pipe's springline.

12.4.3 Initial Backfill

Initial backfill is the portion of pipe embedment that extends from the springline to some distance over the top of the pipe (Fig. 12.4). Since little or no additional side support is gained above the springline by initial backfilling, native soils may be used without employment of special compaction efforts. The sole purpose of the somewhat careful placement of these native trench materials is to protect the pipe from impact loads that might occur during final backfill.

At shallow depths of cover (3 ft and less), flexible conduits can deflect and rebound under dynamic loading conditions if the soil along the trench width is not highly compacted. Unless this compaction is achieved, road surfaces may be damaged. For pipe installed under flexible road surfaces at depths of 3 ft or less, it is recommended that a minimum of 95% Proctor density be achieved from the trench bottom up to the road surface using Class I or Class II materials, as described in Table 12.2. A minimum cover of 1 ft from the top of rigid road surfaces or 1 ft from the bottom of flexible road surfaces is recommended.



Fig. 12.5 Profile wall pipe installation.

12.4.4 Final Backfill

The material used in the final backfilling operation does not need to be as carefully selected as the bedding, haunching, and initial backfill materials. Final backfill material (Fig. 12.4) should have no boulders, frozen clumps of dirt, or rubble that could damage the pipe.

Under improved surfaces and shoulders of streets, roads, aprons, curbs, and walks, the final backfill should be placed using special compaction, as defined by the design engineer. Under open fields, lawns, wide shoulders, unimproved rights-of-way, or neutral grounds which are free of traffic, final backfill should be placed using *natural compaction*.

Table 12.2 Soil classes*

Soil group ^{A,B}	Soil class	American Association of State Highway and Transportation Officials (AASHTO) Soil Groups ^C
Crushed rock, angular ^D : 100% passing 1½ in. sieve, ≤15% passing #4 sieve, ≤25% passing ¾ in. sieve and ≤12% passing #200 sieve	Class I	—
Clean, coarse-grained soils: SW, SP, GW, GP or any soil beginning with one of these symbols, with ≤12% passing #200 sieve ^{E,F}	Class II	A1, A3
Coarse-grained soils with fines: GM, GC, SM, SC, or any soil beginning with one of these symbols, containing >12% passing #200 sieve; sandy or gravelly fine-grained soils: CL, ML, or any soil beginning with one of these symbols, with ≥30% retained on #200 sieve	Class III	A-2-4, A-2-5, A-2-6, or A-4 or A-6 soils with more than 30% retained on #200 sieve
Fine-grained soils: CL, ML, or any soil beginning with these symbols, with <30% retained on #200 sieve	Class IV	A-2-7, A-2-6, A-2-4 with 30% or less retained on #200 sieve
MH, CH, OL, OH, PT	Class V Not for use as embedment	A5, A7

*Reprinted from ASTM D2321 ASTM International, 100 Barr Harbor Dr., West Conshohocken, PA.

^ASee Classification D2487, Standard of Soils for Engineering Purposes (Unified Soil Classification System).

^BLimits may be imposed on the soil group to meet project or local requirements if the specified soil remains within the group. For example, some project applications require a Class I material with minimal fines to address specific structural or hydraulic conditions and the specification may read "Use Class I soil with a maximum of 5% passing the #200 sieve."

^CAASHTO M145, Classification of Soils and Soil Aggregate Mixtures.

^DAll particle faces shall be fractured.

^EMaterials such as broken coral, shells, and recycled concrete, with ≤12% passing a No. 200 sieve, are considered to be Class II materials. These materials should only be used when evaluated and approved by the engineer.

^FUniform fine sands (SP) with more than 50% passing a No. 100 sieve (0.006 in., 0.15 mm) are very sensitive to moisture and should not be used as backfill unless specifically allowed in the contract documents. If use of these materials is allowed, compaction and handling procedures should follow the guidelines for Class III materials.

Natural compaction is attained by the loose placement of material (usually pushed or bladed) into the trench, rolling the surface layer with placement equipment, mounding the surface, and filling and maintaining all sunken trenches until final acceptance of the work. In natural compaction, the main consolidation results from rainfall and groundwater fluctuations.

12.4.5 Embedment Materials

Materials suitable for foundation and embedment are classified in Table 12.2. They include a number of processed materials plus soil types defined in accordance with the Unified Soil Classification System (USCS) in ASTM D2487, Standard Method for Classification of Soils for Engineering Purposes. Table 12.3 provides recommendations on installation and use based on class of soil or aggregates and location of pipe in the trench.

12.4.5.1 Class I Materials

Class I materials provide maximum stability and pipe support for a given density as a result of angular interlock of their particles (Fig. 12.6). With minimum effort these materials can be installed at relatively high densities over a wide range of moisture content. In addition, the good drainage characteristics of Class I materials may aid in the control of water, making these materials desirable for embedment in rock cuts where water is frequently encountered. However, when groundwater flow is anticipated, consideration should be given to the potential for migration of fines (see Section 12.4.6) from adjacent materials into open-graded Class I materials.

12.4.5.2 Class II Materials

Class II materials, when compacted, provide a relatively high level of pipe support. In most respects, they have all the desirable characteristics of Class I materials when widely graded. However, open-graded groups may allow material migration, and the sizes should be checked for compatibility with adjacent material. Typically, Class II materials consist of rounded particles and are less stable than angular materials, unless they are confined and compacted.

12.4.5.3 Class III Materials

Class III materials provide less support for a given density than Class I or II materials. High levels of compactive effort may be required, unless moisture content is controlled. These materials provide reasonable levels of pipe support once proper density is achieved.

Table 12.3 Recommendations for installation and use of soils and aggregates for foundation and pipe-zone embedment*

Soil class ^A	Class I ^B	Class II	Class III	Class IV
General recommendations and restrictions	Acceptable and common where no migration is probable or when combined with a geotextile filter media. Suitable for use as a drainage blanket and underdrain where adjacent material is suitably graded or when used with a geotextile filter fabric.	Where hydraulic gradient exists, check gradation to minimize migration. Clean groups are suitable for use as drainage blanket and underdrain (see Table 12.2). Uniform fine sands (SP) with >50% passing a #100 sieve (0.06 in., 0.15 mm) behave like silts and should be treated as Class IV soils.	Do not use where water conditions in trench prevent proper placement and compaction. Not recommended for use with pipes with stiffness of 9 psi or less.	Difficult to achieve high soil stiffness. Do not use where water conditions in trench prevent proper placement and compaction. Not recommended for use with pipe stiffness of 9 psi or less.
Foundation	Suitable as foundation and for replacing overexcavated and unstable trench bottom as restricted above.	Suitable as foundation and for replacing overexcavated and unstable trench bottom as restricted above. Install and compact in 12 in. (300 mm) maximum layers.	Suitable for replacing overexcavated trench bottom as restricted above. Install and compact in 6 in. (150 mm) maximum layers.	Suitable for replacing overexcavated trench bottom as restricted above. Install and compact in 6 in. (150 mm) maximum layers.

Table 12.3 Recommendations for installation and use of soils and aggregates for foundation and pipe-zone embedment* (*continued*)

Soil class ^A	Class I ^B	Class II	Class III	Class IV
Pipe embedment	Suitable as restricted above. Work material under pipe to provide uniform haunch support.	Suitable as restricted above. Work material under pipe to provide uniform haunch support.	Suitable as restricted above. Difficult to place and compact in the haunch zone.	Suitable as restricted above. Difficult to place and compact in the haunch zone.
Embedment compaction: min recommended % compaction, SPD ^D	See Note ^C	85% (SW and SP soils). For GW and GP soils see Note ^E	90%	95%
Relative compactive effort required to achieve minimum % compaction	Low	Moderate	High	Very high
Compaction methods	Vibration or impact	Vibration or impact	Impact	Impact
Required moisture control	None	None	Maintain near optimum to minimize compactive effort.	Maintain near optimum to minimize compactive effort.

*Reprinted from ASTM D2321 ASTM International, 100 Barr Harbor Dr., West Conshohocken, PA.

^AClass V materials are unsuitable as embedment. They may be used as final backfill as permitted by the engineer.

^BClass I materials have higher stiffness than Class II materials, but data on specific soil stiffness of placed, compacted Class I materials can be taken equivalent to Class II materials compacted to 95% of maximum standard Proctor density (SPD95), and the soil stiffness of compacted Class I materials can be taken equivalent to Class II materials compacted to 100% of maximum standard Proctor density (SPD100). Even if placed uncompacted (that is, dumped), Class I materials should always be worked into the haunch zone to assure complete placement.

^CSuitable compaction typically achieved by dumped placement (that is, uncompacted, but worked into haunch zone to ensure complete placement).

^DSPD is standard Proctor density as determined by Test Method D698.

^EPlace and compact GW and GP soils with at least two passes of compaction equipment.



Fig. 12.6 Backfilling with Class I material.

12.4.5.4 Class IV Materials

Class IV materials should be carefully evaluated prior to use. Moisture content must be near optimum to minimize compactive effort and achieve the required density. Properly placed and compacted Class IV materials can provide reasonable levels of pipe support; however, these materials may not be suitable under high fills, under surface-applied wheel loads, or under heavy vibratory compactors and tampers. Class IV materials should not be used where water conditions in the trench may cause instability and result in uncontrolled water content.

12.4.6 Migration

When coarse or open-graded material is placed adjacent to a finer material, fines may migrate into the coarser material under the action of a hydraulic gradient from groundwater flow. Significant hydraulic gradients may arise in the pipeline trench during construction, when water levels are being controlled by various pumping or well-pointing methods; or after construction, when permeable underdrain or embedment material acts as a trench drain under high groundwater levels.

During construction, downward percolation of surface water can carry fine granular haunching materials down into more coarse, open-graded bedding materials if the trench is not properly designed and constructed. The gradation and relative size of the embedment and adjacent materials must be compatible in order to minimize migration. In general, where significant groundwater flow is anticipated, placement of coarse, open-graded materials (such as Class I) above, below, or adjacent to finer materials should be avoided, unless

methods are employed to impede migration, such as the use of an appropriate stone filter or filter fabric along the boundary of the incompatible materials.

12.4.7 Embedment Compaction

The moisture content of embedment materials should be maintained within suitable limits that permit placement and compaction to required levels with reasonable efforts. For non-free-draining soils, such as Class III and IV, moisture content should be held close to optimum. In applications where water exists in the trench, free-draining embedment materials are generally more suitable because they are more readily densified while saturated. Maximum particle size for embedment is limited to material passing a 1½-inch (38-mm) sieve.

Contact with pipe is to be avoided when mechanical compactors are used; when a small mechanical compactor for compacting over the pipe crown is used, a minimum of 6 in. (150 mm) of cover must be maintained, and for larger compactors, minimum clearances as the engineer requires are to be maintained. Decisions are to be based on the depth of influence of the specific compaction equipment being used. For compaction by heavy wheel loading or hydro hammer methods, a minimum distance of 30 in. over the pipe crown (top) may be required. Heavy wheel loading and hydrohammer methods of compaction should not be used for compacting in shallow bury applications, where total cover is less than the influence zone of the compaction device. In shallow cover applications, materials requiring little to no mechanical compaction should be used for embedment.

The methods chosen to deliver compactive energy determine whether desired densities for specific types of materials are achieved. Coarse-grained, clean materials such as crushed stone, gravels, and sand are free-flowing and may not require mechanical compaction in some installations. These materials are more readily compacted using vibratory equipment, whereas fine materials with high plasticity require kneading and impact force along with controlled water content to achieve acceptable densities. In pipe trenches, small handheld or walk-behind compactors work well not only to prevent damage to the pipe, but to ensure thorough compaction in confined areas around the pipe and along the trench wall. As examples, vibratory plate tampers work well for coarse-grained materials of Class I and Class II, whereas hand tampers or air-driven handheld impact rammers are suitable for the fine-grained plastic groups of Classes III and IV. Gas- or diesel-powered jumping jacks or small, walk-behind vibratory rollers impart both vibratory and kneading forces and are therefore suitable for most classes of embedment and backfill material.

Table 12.4 provides an approximate guide of obtainable densities of various soils by a variety of compaction methods. The minimum embedment density required is typically determined by the project engineer during design and will depend upon depth of cover,

Table 12.4 Estimated range of compaction* by embedment class and method of placement

Class of embedment	I	II	III	IV
Material description	Manufactured granular materials	Sand and gravel soils, clean	Mixed-grain soils	Fine-grain soils
Optimum moisture content range limit, % of dry wgt	—	9–12	9–18	6–30
Soil consolidation method	% of Proctor (or relative) density range			
Compact by power tamper or rammer	95–100 (75–100)	95–100 (60–80)	95–100	90–100
Densify by portable vibrators	80–95 (60–75)	80–95 (60–80)	—	—
Hand place	60–80 (40–60)	—	—	—
Hand tamp	—	60–80 (50–60)	60–80	60–75
Dump	60–80 (40–60)	60–80 (50–60)	60–80	60–75

*Compaction given in standard Proctor densities, relative density is noted in parentheses.

Note: This table serves as an approximate guide defining average Proctor densities attained through various methods of soil consolidation in different classes of soil. The table is intended to provide guidance and is not recommended for design use. Actual design values should be developed by the engineer for specific soils at specific moisture contents.

pipe stiffness, and type of soil used. For additional information on required densities, see Chapter 7, Design of Buried PVC Pipe.

12.4.8 Common Trenches

PVC pipe may be used in a common trench with either another flexible pipe or rigid pipe. In either case, the installer need only obtain sufficient soil stiffness around the pipe to maintain structural integrity. Spacing between pipes in a common trench should be at least 12 in. to permit adequate space for tamping or mechanical compaction. Consideration should also be given to whether Class I or Class II embedment materials should be used, which require minimal compaction effort.



Fig. 12.7 PVC pipe may be anchored on steep slopes.

If water and sewer pipes are installed in common trenches, the water pipe is laid higher in the trench to minimize any possibility of contamination. Gasketed PVC water and sewer pipe with joints conforming to ASTM D3139 and ASTM D3212 do not require external protective wrap applied at the joints when installed in a common trench. Joint tightness specified in the ASTM standards is sufficient to prevent any infiltration or exfiltration.

12.4.9 Sewers on Steep Slopes

It is recommended that sewers on steep slopes (greater than 20°)—where shallow-bury and/or poorly consolidated soil conditions exist—be anchored securely with concrete collars or other appropriate abutments immediately downhill from bells to prevent downhill movement of pipe (Fig. 12.7).

12.4.10 Recommended Embedment Densities

Table 12.5 provides a quick reference of recommended embedment material class and density combinations for burial depths up to 50 ft (15.2 m). Burial depths in excess of 50 ft are permissible.

Table 12.5 Recommended pipe zone conditions for pipe stiffness of 46 psi

Pipe zone conditions		Height of cover	
Embedment class	% Proctor density range	ft	m
I	95–100	≤50	≤15.2
II	90–100	≤50	≤15.2
	85	≤40	≤12.2
	80	≤24	≤7.3
III	90–100	≤50	≤15.2
	85	≤36	≤11.0
	80	≤14	≤4.3
IV	85–100	≤32	≤9.8
	80	≤12	≤3.7
V	Soil class not recommended		

Notes:

1. Table is applicable only when minimum pipe stiffness is 46 psi.
2. At heights of cover shown, deflections will not exceed 7.5% when proper installation procedures are used. This provides a safety factor ratio of 4 to 1 against structural failure.
3. Actual installations in excess of 50 ft are possible and have been successfully completed. For recommended pipe zone conditions for PVC pipe of other stiffness conforming to ASTM F794 or AASHTO M304, the pipe manufacturer should be contacted.

12.5 System Components

PVC pipes are used in various nonpressure piping applications such as drainage, venting, and sewage systems. The recommendations that follow (Sections 12.5.1 through 12.5.5) are made for PVC piping used in gravity sewer systems. Sewer systems can convey storm drainage, sanitary sewage, or both. The great majority of sewage collection systems in North America are nonpressure systems using open-channel gravity flow. Sewer systems are carefully designed and constructed and depend upon proper use of pipe and appurtenances.

12.5.1 Fittings

Fittings for service branches in new construction should be molded or fabricated PVC fittings. Connections into existing lines are commonly done using:

- gasketed tee leg inserted into a hole cut into the main line
- gasketed saddle wye
- gasketed saddle tee.

Saddles may be gasketed or solvent-cemented and should be secured to the sewer main by corrosion-proof banding.

Saddles should be installed in accordance with manufacturer recommendations. Holes for saddle connections should be made by mechanical hole-cutters designed for this purpose. Holes for wye saddles should be laid out with a template and deburred and carefully beveled where necessary to provide a smooth hole that is shaped to conform to the fitting. Installed fittings should not compromise the system integrity by allowing infiltration or exfiltration.

Fittings are required for lateral connections, clean-out access, and changes in line direction and/or size (not occurring in manholes). Tees, wyes, or tee-wyes are provided for service connections, risers, and clean-outs. Increasers are used for changes in line size. Caps or plugs are used at dead ends. Commonly used fittings are shown in Figs. 12.8 and 12.9. Elbows and bends are used where line direction changes, particularly at service connections into sewer main lines (see Fig. 12.10).

12.5.2 Service Lines

Normally, service lines that extend from property line to collection sewer should lie at a minimum depth of 3 ft (1 m) at property line; they should be laid to a straight alignment and uniform slope no less than $\frac{1}{4}$ in./ft (20 mm/m) for 4-in. (100-mm) pipe and not less than $\frac{1}{8}$ in./ft (10 mm/m) for 6-in. (150-mm) pipe. A vertical standpipe or stack is commonly permitted where collection sewers are deeper than 7 ft (2 m). Standpipes and stacks do not require concrete encasement; however, they should be uniformly supported by compacted backfill.

Sanitary sewer service connections vary in size, depending on local codes, regulations, and system requirements. Service connections for large industrial, municipal, or commercial installations may be quite large, whereas most service connections for private residences are usually 4-in. or 6-in. pipe. Service connections may be made with fittings

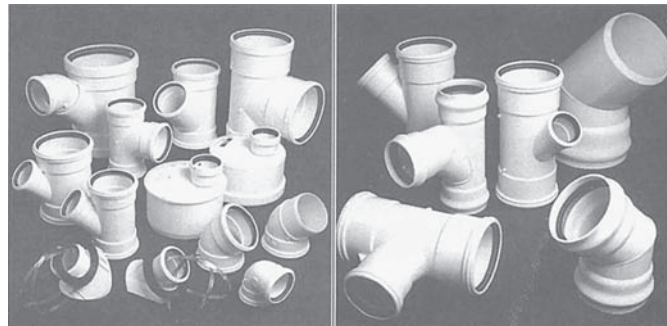

Fig. 12.8 Solid-wall PVC sewer fittings.

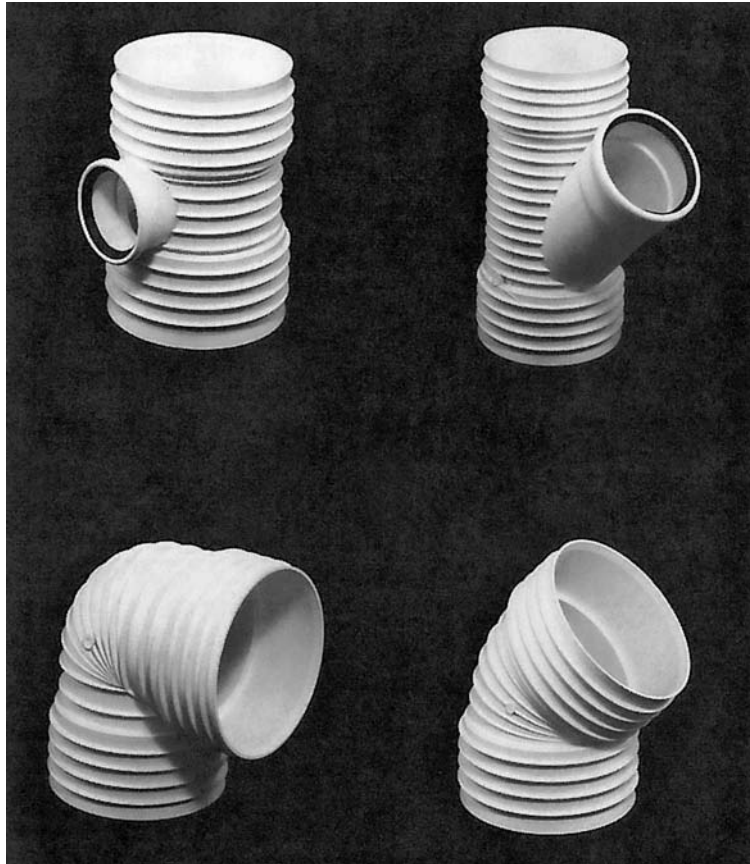

Fig. 12.9 Profile wall PVC sewer fittings.

installed in the sanitary sewer main line (tee, wye, or tee-wye) with field-installed service saddles (gasketed and clamped or solvent-cemented) or with tee legs inserted into the main line with the use of rubber gaskets.

The following are precautions to be taken when a field cut-in service connection is required:

- Foreign material should be prevented from entering cut-in pipe opening.
- Proper fittings and procedures should be used when field-connection saddles are installed.

The pipe manufacturer should be contacted for specific recommendations.

12.5.3 Pipe Caps and Plugs

All caps and plugs should be braced, staked, anchored, wired-on, or otherwise secured to the pipe to prevent leakage under the maximum anticipated thrust that results from abnormal internal operating conditions or test pressures from water or air.

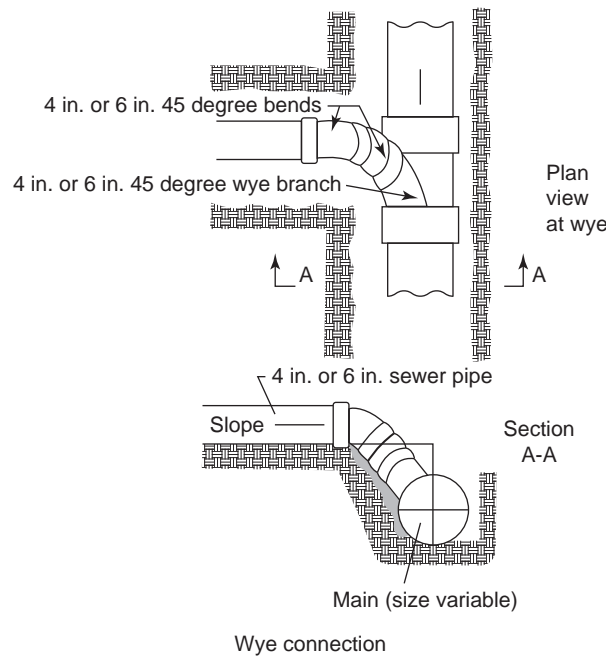

Fig. 12.10 Typical service connection.

12.5.4 Risers

Sewer risers or vertical stacks may be required in deep sanitary sewers to minimize the need to excavate for service lines. Risers are generally permitted where the collection line is deeper than 7 ft (2 m).

For installation of PVC riser pipes on a PVC sewer line, the following practices are recommended:

- Use of a tee or tee-wye fitting and 45° elbow, or wye fitting and elbows to connect PVC riser pipe to the sewer line.
- Uniform support at the riser pipe connection by uniform bedding with good compaction all around and up the pipe.
- Use of a single length of pipe for the riser section whenever possible (up to 13 ft).
- Alignment of the lateral exit from the main at an angle no greater than 45° from the horizontal.
- Good compaction in the haunching from the base to the springline of the fitting and sewer line; this can be achieved with select material, if necessary.

Designers of very tall risers, in the case of deep main line sewers, must examine vertical loads that will be exerted on main line sewer fittings. These loads should be mitigated or

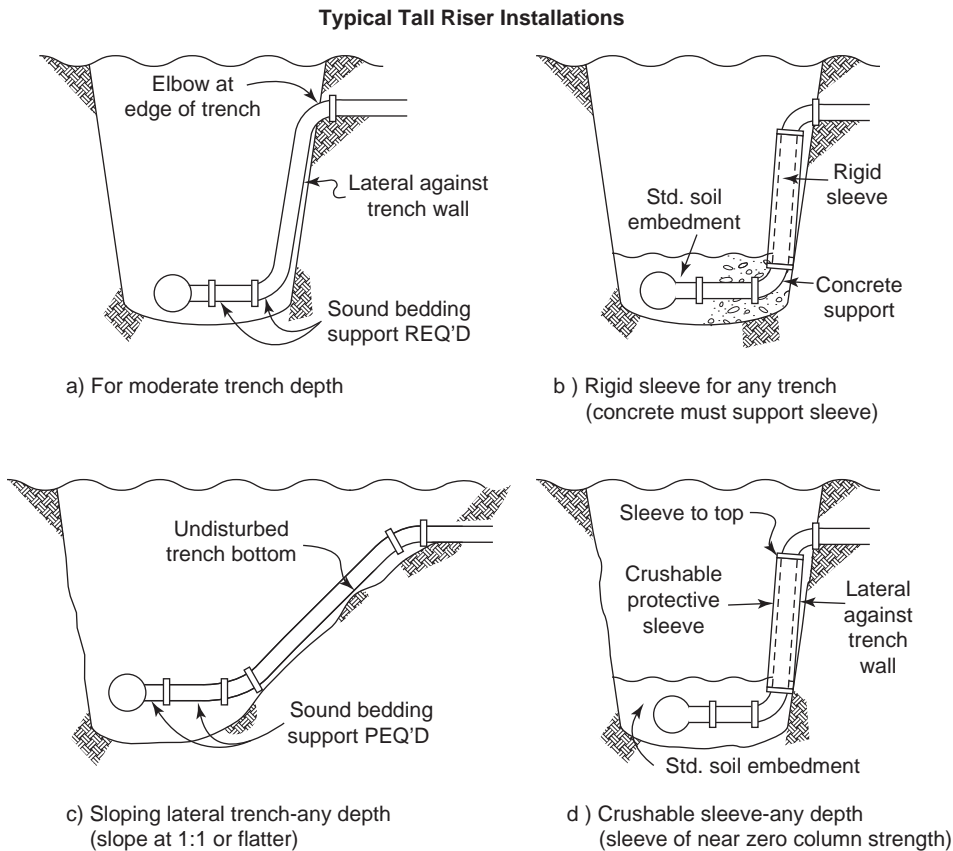

Fig. 12.11 Typical tall-riser installations.

transferred harmlessly off the stack so that possible overinsertion, fracture of the fitting, or misalignment is prevented. Figure 12.11 shows typical tall-riser installations that help to minimize the vertical forces applied to the main line sewer due to soil settlement around the riser stack. The use of blunt tapers in these installations also can aid in prevention of stack settlement into the main line sewer.

12.5.5 Manholes and Junctions

Manholes and junctions are essential to the operation and maintenance of gravity sewer systems. Manholes are required to:

- provide workers access to the sewer line for inspection and maintenance;
- provide control of hydraulic flow for a change of direction, a change of grade, and for consolidation of converging flow channels (Fig. 12.12).



Fig. 12.12 Sewer pipe laid through and beyond manhole location prior to construction of manhole.

Manholes are commonly located at street intersections. Typically, intervals between sanitary sewer manholes vary from 300 (90 m) to 500 ft (150 m). Intervals between manholes may be greater for pipe products like PVC sewer pipe, which significantly minimizes cleaning and maintenance problems as compared to piping products that exhibit poor flow characteristics and are prone to root penetration and damage.

Manhole connections need to be watertight; a leak-free connection of sewer pipe to manholes has become more important. Emphasis is on system design, sizing, and operating



Fig. 12.13 An example of a watertight manhole connection.

cost incurred due to groundwater infiltration. Unlike some other sewer piping materials, PVC pipe does not bond with concrete. So, a PVC pipe/manhole connection must be accomplished using some form of watertight seal or waterstop (Fig. 12.13). Manhole connections can be made as follows:

- Manhole couplings, providing an elastomeric gasket seal, can be grouted into the manhole wall.
- Waterstop in various forms (i.e., flexible boot or sleeve, O-ring, or gasket), produced from elastomeric compound, can be grouted or locked into manhole wall.
- Connection ports with elastomeric seals can be precast into manhole wall.
- Grouted connections directly to PVC pipe are effective if the pipe at the connection is coated with sand.

ASTM C923, Standard Specification for Resilient Connectors between Reinforced Concrete Manhole Structures, Pipes, and Laterals, contains additional discussion on manhole connections. Connections covered by ASTM C923 withstand hydrostatic pressures up to 10 psi (70 kPa).

Customarily, drop manholes are required when the difference in incoming and outgoing invert elevations is 2 ft (0.6 m) or more. Drop manhole connections must adhere to guidelines described above, and fittings should be installed to provide the requisite line profile. PVC pipe drop manholes may be designed in either inside-drop or outside-drop manhole configurations. Recommendations for making a proper connection in each case are detailed in Figs. 12.14 and 12.15.

PVC Nonpressure Pipe Installation

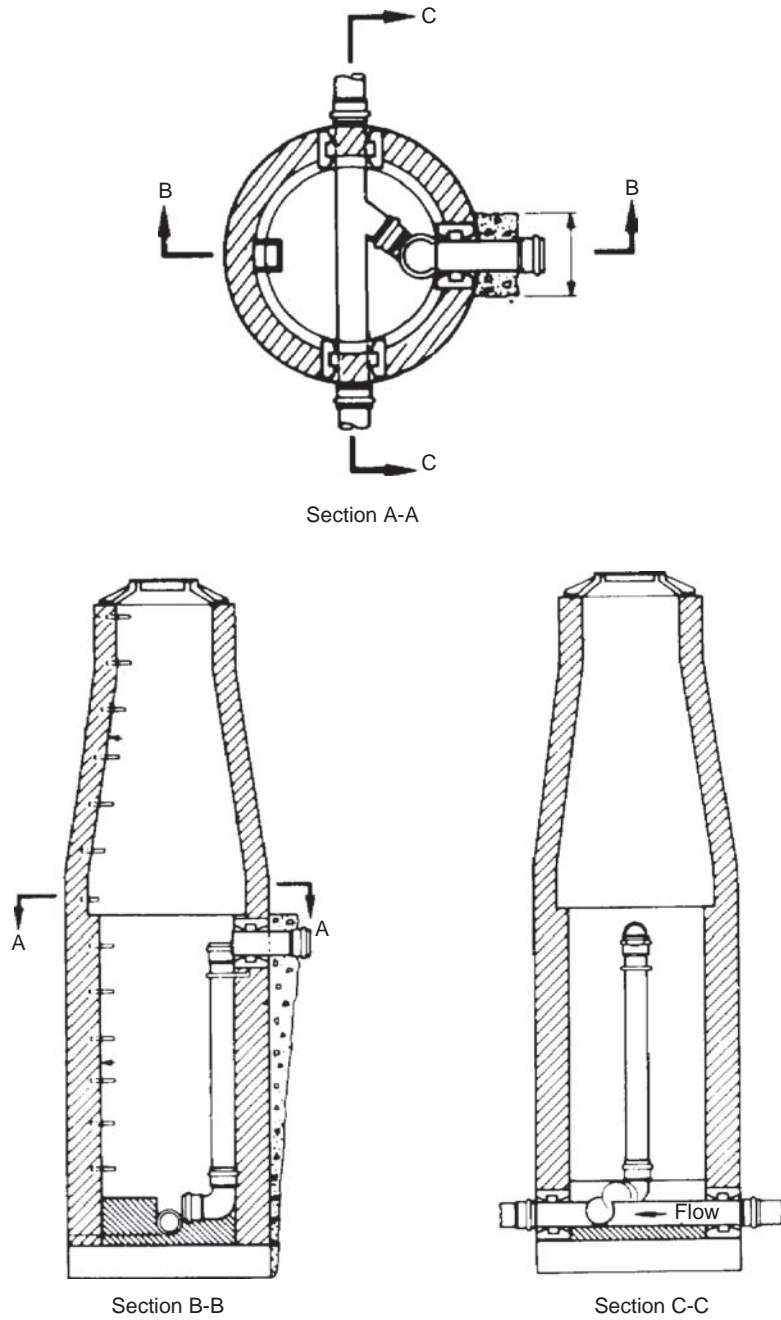

Fig. 12.14 Inside-drop manhole connection.

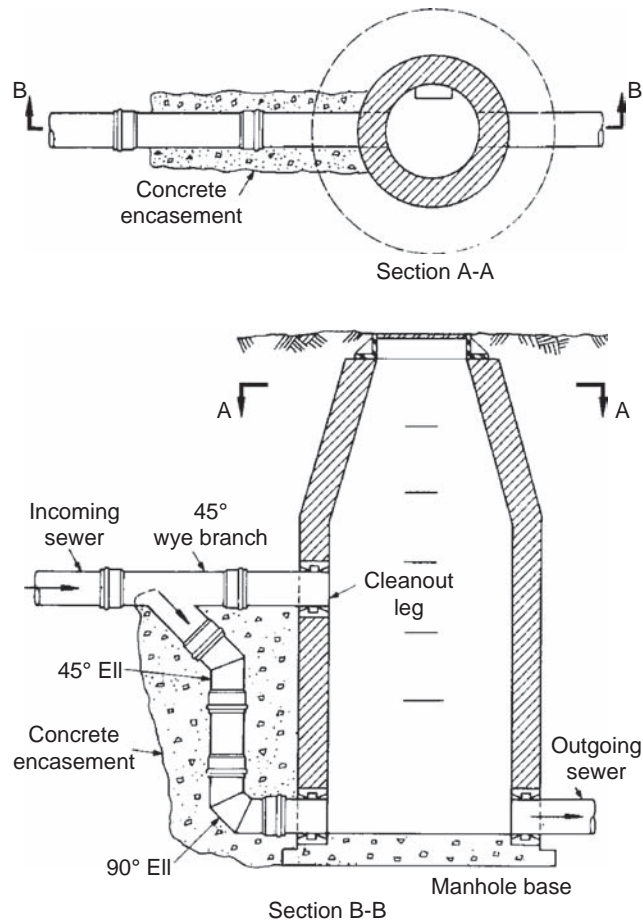

Fig. 12.15 Outside-drop manhole connection.

Connections must be done in a way that ensures proper compaction in pipe bedding and haunching. Rigid structures have to be properly bedded and installed. Settlement or shifting of rigid structures will normally not cause shear breakage, as is common with rigid piping products. However, excessive shifting or settlement could cause excessive deflection or distortion. Consequently, it is good practice for PVC pipes to have a gasketed pipe joint within 3 ft (1 m) of each side of the manhole to accommodate possible manhole settling (Fig. 12.16). In the case of outside-drop manholes, the concrete around the outside pipe provides support and eliminates drag-down loads.

Where flow velocities are greater than 15 ft/s, it is customary for baffles, cushioning, or energy dissipation within manholes to be provided. However, this practice is unrelated to PVC pipe performance (i.e., flow velocity does not limit design for PVC pipes).



Fig. 12.16 Placing a gasketed pipe joint within 3 ft of each side of the manhole helps to accommodate possible manhole settlement.

12.6 Inspection and Testing of the Pipe System

Good practice calls for all piping system projects to be tested upon completion of installation. The engineer should designate:

- locations of tests
- extent of the system to be tested
- optional methods of testing leakage
- alignment and deflection
- requirements for recording test results.

Sections of sewer that fail the tests should have defects located and then repaired or replaced. Any such sections should be retested until results are within specified allowances.

12.6.1 Precleaning

Prior to testing, sewer lines should be cleaned by flushing with an appropriately sized sewer cleaning ball. Precleaning by high velocity jet or other method may be necessary.

12.6.2 Visual Inspection

Sewer lines can be inspected visually to verify accuracy of alignment and freedom from debris and obstruction. The testing method can be photography, closed circuit television, or visual lamping with mirrors and lights.

12.6.3 Leakage Testing

Suitable leak testing methods are low-pressure air exfiltration, water infiltration, or water exfiltration. The preferred method is usually the low-pressure air exfiltration test. Plugs or caps on branch connections must be secured against blow-off during leakage tests.

12.6.3.1 Air Testing

The minimum time duration permitted for the prescribed low-pressure exfiltration pressure drop between two consecutive manholes should not be less than what is listed in Tables 12.6 or 12.7. Test duration values are listed for pressure drops of 1.0 psi (Table 12.6) and 0.5 psi (Table 12.7), respectively, in excess of groundwater pressure above the top of the sewer pipe. The values given accommodate both an allowable average loss per unit of surface area and an allowable maximum total leakage rate. This approach is based on the most recent work of Ramseier and eliminates the possibility of the acceptance of one or two significant leaks in an otherwise good section of pipe (see ASTM F1417 Standard Test Method for Installation Acceptance of Plastic Gravity Sewer Lines Using Low-Pressure Air; and Uni-Bell, UNI-B-6 Recommended Practice for Low-Pressure Air Testing of Installed Sewer Pipe).

12.6.3.2 Infiltration/Exfiltration Testing

Infiltration testing is an acceptable method of leakage test only when the ground level water is above the top (crown) of the pipe throughout the length being tested. The allowable infiltration for any portion of sewer system should be measured by a weir or current meter placed in the appropriate manhole and should not exceed 25 gal/in. of internal pipe diameter/mi/day (2.3 L/mm/km/day), including manholes.

Exfiltration testing is an acceptable testing method only in dry areas or where a line is sufficiently deep and groundwater level above the pipe is suitably low, so test pressures can exceed the external pressure generated by groundwater. The allowable water exfiltration for any length of sewer pipe between manholes should not exceed 25 gal/in. of internal pipe diameter/mi/day. During exfiltration testing the maximum internal pipe pressure at the lowest end should not exceed 25 ft (7.6 m) of water or 10.8 psi (75 kPa), and the water level inside the manhole should be 2 ft (0.6 m) higher than the top of the pipe or 2 ft (0.6 m) higher than groundwater level (whichever is greater).

12.6.4 Deflection Testing

Deflection tests of pipe may be required. They are performed before final acceptance. Locations with excessive deflection should be repaired by rebedding or replacing pipe.

Table 12.6 Specification time required for a 1.0 psig pressure drop for size and length of pipe indicated for $Q = 0.0015^*$

1 Pipe diam, in.	2 Minimum time, min:s	3 Length for minimum time, ft	4 Time for longer length, s	Specified minimum time for length (L) shown (min:s)							
				100 ft	150 ft	200 ft	250 ft	300 ft	350 ft	400 ft	450 ft
4	3:46	597	0.380 L	3:46	3:46	3:46	3:46	3:46	3:46	3:46	3:46
6	5:40	398	0.854 L	5:40	5:40	5:40	5:40	5:40	5:40	5:42	6:24
8	7:34	298	1.520 L	7:34	7:34	7:34	7:34	7:36	8:52	10:08	11:24
10	9:26	239	2.374 L	9:26	9:26	9:26	9:53	11:52	13:51	15:49	17:48
12	11:20	199	3.418 L	11:20	11:20	11:24	14:15	17:05	19:56	22:47	25:38
15	14:10	159	5.342 L	14:10	14:10	17:48	22:15	26:42	31:09	35:36	40:04
18	17:00	133	7.692 L	17:00	19:13	25:38	32:03	38:27	44:52	51:16	57:41
21	19:50	114	10.470 L	19:50	26:10	34:54	43:37	52:21	61:00	69:48	78:31
24	22:40	99	13.674 L	22:47	34:11	45:34	56:58	68:22	79:46	91:10	102:33
27	25:30	88	17.306 L	28:51	43:16	57:41	72:07	86:32	100:57	115:22	129:48
30	28:20	80	21.366 L	35:37	53:25	71:13	89:02	106:50	124:38	142:26	160:15
33	31:10	72	25.852 L	43:05	64:38	86:10	107:43	129:16	150:43	172:21	193:53
36	34:00	66	30.768 L	51:17	76:55	102:34	128:12	153:50	179:29	205:07	230:46
42	39:48	57	41.883 L	69:48	104:42	139:37	174:30	209:24	244:19	279:13	314:07
48	45:34	50	54.705 L	91:10	136:45	182:21	227:55	273:31	319:06	364:42	410:17
54	51:02	44	69.236 L	115:24	173:05	230:47	288:29	346:11	403:53	461:34	519:16
60	65:40	40	85.476 L	142:28	213:41	284:55	356:09	427:23	498:37	569:50	641:04

*Q is the allowable leakage rate in $\text{ft}^3/\text{min}/\text{ft}^2$ of inside surface area of pipe.

Note: If no leakage (0 psig drop) is seen after 1 h of testing, the test section shall be accepted.

Table 12.7 Specification time required for a 0.5 psig pressure drop for size and length of pipe indicated for $Q = 0.0015^*$

1 Pipe diameter (in.)	2 Minimum time (min:s)	3 Length for minimum time (ft)	4 Time for longer length (s)	Specified minimum time for length (L) shown (min:s)							
				100 ft	150 ft	200 ft	250 ft	300 ft	350 ft	400 ft	450 ft
4	1:53	597	0.190 L	1:53	1:53	1:53	1:53	1:53	1:53	1:53	1:53
6	2:50	398	0.427 L	2:50	2:50	2:50	2:50	2:50	2:50	2:51	3:12
8	3:47	298	0.760 L	3:47	3:47	3:47	3:47	3:48	4:26	5:04	5:42
10	4:43	239	1.187 L	4:43	4:43	4:43	4:57	5:56	6:55	7:54	8:54
12	5:40	199	1.709 L	5:40	5:40	5:42	7:08	8:33	9:58	11:24	12:50
15	7:05	159	2.671 L	7:05	7:05	8:54	11:08	13:21	15:35	17:48	20:02
18	8:30	133	3.846 L	8:30	9:37	12:49	16:01	19:14	22:26	25:38	28:51
21	9:55	114	5.235 L	9:55	13:05	17:27	21:49	26:11	30:32	34:54	39:16
24	11:20	99	6.837 L	11:24	17:57	22:48	28:30	34:11	39:53	45:35	51:17
27	12:45	88	8.653 L	14:25	21:38	28:51	36:04	43:16	50:30	57:42	64:54
30	14:10	80	10.683 L	17:48	26:43	35:37	44:31	53:25	62:19	71:13	80:07
33	15:35	72	12.926 L	21:33	32:19	43:56	53:52	64:38	75:24	86:10	96:57
36	17:00	66	15.384 L	25:39	38:28	51:17	64:06	76:55	89:44	102:34	115:23
42	19:74	57	20.942 L	34:54	52:21	69:49	87:15	104:42	122:10	139:37	157:04
48	22:47	50	27.352 L	45:35	68:23	91:11	113:58	136:46	159:33	182:21	205:09
54	25:31	44	34.618 L	57:42	86:33	115:24	144:15	173:05	201:56	230:47	259:38
60	28:20	40	42.738 L	71:14	106:51	142:28	178:05	213:41	249:18	284:55	320:32

*Q is the allowable leakage rate in $\text{ft}^3/\text{min}/\text{ft}^2$ of inside surface area of pipe.

Note: If no leakage (0 psig drop) is seen after 1 h of testing, the test section shall be accepted.

PVC Nonpressure Pipe Installation

Table 12.8 Base inside diameters and deflection mandrel dimensions for ASTM D3034 DR 35 pipe

Pipe size, in.	Base inside diameter, in.	7.5% mandrel deflection, in.
6	5.742	5.31
8	7.665	7.09
10	9.563	8.84
12	11.361	10.51
15	13.898	12.86

Table 12.9 Base inside diameters and deflection mandrel dimensions for ASTM F679 PS 46 pipe

Pipe size, in.	Base inside diameter, in.	7.5% mandrel deflection, in.
18	17.054	15.77
21	20.098	18.59
24	22.586	20.89
27	25.446	23.53
30	29.151	26.96
36	34.869	32.25
42	40.491	37.45
48	46.209	42.74

Deflection testing is usually performed with a properly sized “go/no-go” mandrel or sewer ball. For the purpose of deflection measurements, base inside pipe diameters are provided in Tables 12.8 and 12.9. The maximum allowable deflection should be subtracted from base inside diameter to determine the maximum diameter of the “go/no-go” test mandrel or ball. It must be emphasized that accurate testing is possible only when the lines are thoroughly cleaned. This test is recommended for all pipe materials.

ASTM standards address deflection testing of PVC sewer pipe. If deflection testing is performed on installed pipe, it is recommended that a deflection limit of 7.5% of base inside diameter be used. To allow for stabilization of the pipe/soil system, deflection

testing should be performed a minimum of 30 days after installation. Tests have shown that when PVC pipe is held under constant strain below the ultimate limit that would cause breakage, pipe failure will not occur. Additionally, PVC pipe does not experience reversal of curvature until deflection exceeds 30%. Decades of experience and testing have shown that a deflection limit of 7.5%, offering a safety factor of 4, provides for PVC pipelines that will meet or exceed the design life of the system.

Base ID depends on pipe average ID and a statistical tolerance package. The formulas are as follows:

Equation 12.1

$$ID_{avg} = OD_{avg} - 2(1.06) t$$

Equation 12.2

$$\text{tolerance package} = \sqrt{A^2 + 2B^2 + C^2}$$

Equation 12.3

$$ID_{base} = ID_{avg} - \text{tolerance package}$$

where:

ID_{avg} = pipe average inside diameter, in.

OD_{avg} = pipe average outside diameter, in.

t = minimum wall thickness (ASTM D3034 or F679), in.

A = OD tolerance (ASTM D3034 or F679), in.

B = excess wall thickness tolerance, in. = $0.06 t$

C = out-of-roundness tolerance (ASTM D3034 or F679), in.

ID_{base} = pipe base inside diameter, in.

Using a similar methodology, base inside diameters have also been developed for profile wall pipe manufactured in accordance with UNI-B-9, Recommended Performance Specification for Polyvinyl Chloride (PVC) Profile Wall Gravity Sewer Pipe and Fittings Based on Controlled Inside Diameter (Nominal Pipe Sizes 4–48 Inch). These are listed in Table 12.10, along with the suggested mandrel dimensions. Open, closed, and dual-wall corrugated profiles are specified in the UNI-B-9 standard, in which base inside diameters were calculated using out-of-roundness tolerances for similar-sized pipe from ASTM specifications D3034 and F679. Where no similar sizes existed, tolerances were extrapolated to the desired size.

Table 12.10 Base inside diameters and deflection mandrel dimensions for profile-wall PVC pipe*

Pipe size, in.	Base inside diameter, in.	7.5% mandrel deflection, in.
4	3.864	3.57
6	5.725	5.29
8	7.637	7.06
10	9.525	8.81
12	11.312	10.46
15	13.828	12.79
18	16.923	15.65
21	19.956	18.46
24	22.600	20.90
27	25.446	23.54
30	28.350	26.22
33	31.249	28.91
36	34.106	31.55
39	37.003	34.23
42	39.880	36.89
45	42.762	39.56
48	45.639	42.22

*Recommended for use with ASTM F794, F949, and F1803 products.

12.7 Sources

AASHTO M145, Classification of Soils and Soil Aggregate Mixtures. American Association of State Highway and Transportation Officials, Washington, DC (2003).

AASHTO M304, Polyvinyl Chloride (PVC) Profile Wall Drain Pipe and Fittings Based on Controlled Inside Diameter. American Association of State Highway and Transportation Officials.

ASTM C923, Resilient Connectors between Reinforced Concrete Manhole Structures, Pipes, and Laterals. ASTM International, West Conshohocken, PA (2008).

ASTM D698, Standard Test Methods for Laboratory Compaction Characteristics of Soil Using Standard Effort (12,400 ft-lbf/ft³ (600 kN-m/m³

ASTM D1556, Standard Test Method for Density and Unit Weight of Soil In-Place by the Sand-Cone Method. ASTM International (2007).

ASTM D2049, Standard Method of Test for Relative Density of Cohesionless Soils. ASTM International (1969).

ASTM D2167, Standard Test Method for Density and Unit Weight of Soil In-Place by the Rubber Balloon Method. ASTM International (2008).

ASTM D2321, Standard Practice for Underground Installation of Thermoplastic Pipe for Sewers and Other Gravity-Flow Applications. ASTM International (2009).

ASTM D2487, Standard Method for Classification of Soils for Engineering Purposes. ASTM International (2010).

ASTM D2488, Standard Practice for Description and Identification of Soils (Visual-Manual) Procedure. ASTM International (2009).

ASTM D2855, Standard Practice for Making Solvent-Cemented Joints with Polyvinyl Chloride (PVC) Pipe and Fittings. ASTM International (1996).

ASTM D2922, Standard Test Method for Density of Soil and Soil-Aggregate in Place by Nuclear Methods (Shallow Depth). ASTM International (2004).

ASTM D3034, Standard Specification for Type PSM Polyvinyl Chloride (PVC) Sewer Pipe and Fittings. ASTM International (2008).

ASTM D3212, Standard Specification for Joints for Drain and Sewer Plastic Pipes Using Flexible Elastomeric Seals. ASTM International (2007).

ASTM F679, Standard Specification for Polyvinyl Chloride (PVC) Large-Diameter Plastic, Gravity Sewer Pipe and Fittings. ASTM International (2008).

ASTM F794, Polyvinyl Chloride (PVC) Profile Gravity Sewer Pipe and Fittings Based on Controlled Inside Diameter. ASTM International (2009).

ASTM F949, Polyvinyl Chloride (PVC) Corrugated Sewer Pipe with a Smooth Interior and Fittings. ASTM International (2010).

ASTM F1417, Standard Practice for Installation Acceptance of Plastic Non-pressure Sewer Lines Using Low-Pressure Air. ASTM International (2011).

ASTM F1803, Polyvinyl Chloride (PVC) Closed Profile Gravity Pipe and Fittings Based on Controlled Inside Diameter. ASTM International (2006).

Barnard, R.E., Design and deflection control of buried steel pipe supporting earth and live loads, ASTM, Proc. 57. (1957).

CSA B182.2 PVC Sewer Pipe and Fittings (PSM Type). Canadian Standards Association, Mississauga, Ontario, Canada (2011).

PVC Nonpressure Pipe Installation

12.37

- Gravity Sanitary Sewer Design and Construction, ASCE Manual and Report on Engineering Practice No. 60 (WPCF Manual of Practice FD-5).* American Society of Civil Engineers and the Water Pollution Control Federation, New York, NY (1982).
- Hobbs, S.H., Cherne, L.G. Air Testing Sanitary Sewers. Paper presented at the 40th Annual Conference of the Water Pollution Control Federation, New York, NY (1967).
- Policy and Guidelines to Govern the Use of Plastic Pipe for Buried Gravity-Flow Sewers.* Ministry of the Environment, Toronto, ON (1979).
- Ramseier, R.E., Testing new sewer pipe installations. *Journal Water Pollution Control Federation*, Washington, DC (April 1972).
- Ramseier, R.E., Riek, G.C., Experience in using the low-pressure air test for sanitary sewers. *Journal Water Pollution Control Federation*, Washington, DC (Oct. 1966).
- Ramseier, R.E., Riek, G.C., Low pressure air test for sanitary sewers. *Journal of the Sanitary Engineering Division, Proceedings of the American Society of Civil Engineers*, Vol. 90, No. SA 2 (April 1964).
- Schluter, J.C., Riser problems demand the designer's attention. *Uni-Bell PVC Pipe News*, Vol. 11, No. 1 (1988).
- Symons, G.E., *Wastewater Systems—Pipes and Piping, Manual of Practice Number Three, Water and Wastes Engineering.* Dun-Donnelley Publishing Corporation, New York, NY (1967).
- UNI-B-1, Recommended Specification for Thermoplastic Pipe Joints, Pressure and Non-Pressure Applications. Uni-Bell PVC Pipe Association, Dallas, TX (2002).
- UNI-B-6, Recommended Practice for Low-Pressure Air Testing of Installed Sewer Pipe. Uni-Bell PVC Pipe Association (1990).
- UNI-B-9, Recommended Performance Specification for Polyvinyl Chloride (PVC) Profile Wall Gravity Sewer Pipe and Fittings Based on Controlled Inside Diameter (Nominal Pipe Sizes 4-48 Inch). Uni-Bell PVC Pipe Association (1990).
- Weall, A.J., Some practical construction considerations. *Uni-Bell PVC Pipe News*, Vol. 1, No. 2 TX (1978).
- Young, G.R., Comprehensive Acoustical Leak Detection. 1988 AWWA Annual Conference Proceedings, Part 1, Orlando, FL (1988).

