

Hammond® Vintage

by Dan.Vigin

Handy Wiring Guide for B3/C3 TWG



Hammond® and Leslie® are registered trademarks of Suzuki Musical Instrument Manufacturing Co. Ltd.

Binche / Belgium

May 2015

Table of contents.

1.	Forewords and Purpose.	P. 3
2.	TWG to keyboards wiring concept	P. 4
3.1	Table #1 – Legend (glossary)	P. 6
3.2	Table #2 – Wiring to Upper and Lower keyboards	P. 7
3.3	Table #3 – Wiring to Pedal keyboard	P. 8
4.	Another way to proceed	P. 9
5.	Other surrounding wiring	P. 9
7.	My conclusion	P.10

Appendix #1 – Hammond Note Nbr/'Key' Ref./Related frequency

" Handy Wiring Guide for B3/C3 TWG "

1. Forewords – Purpose of this article.

It happens during the B3/C3 lifetime that upper and lower keyboards assembly have to be pulled out from the cabinet and put on the workbench for several reasons such as :

- removing black caustic foam
- replacement of contacts
- dendrites cleaning
- dead note,
- open tapering leads,
- and there are more...

Less frequently, similar problems may also appear at pedal keyboard.

In any case, all wirings from TWG (*) to keyboards have to be unsoldered.

Inversely, same situation may be encountered if TWG has to be removed out from the cabinet in case of coil pick-up replacement f.i. and the like.

When remounting, there is absolutely no room for any wiring error. Since all cables are laced and black coloured, during re-soldering, it's sometimes confusing.

Of course, indications are available in the service manual but to my opinion, such information are not clear enough, printed in very small characters and it is not always easy to find one's bearings.

Most of the time, B3/C3 service manuals are copy of copy of copy ... so at the end it becomes simply unreadable.

Then, I have decided to investigate that specific matter and come up with a "handy wiring guide" in order to facilitate that re-cabling operation without any possible wiring mistake. That was the initial intention.

The note position of keyboard is added at each terminal of TWG according to the Hammond table III entitled " *Frequency numbers assigned to keys and pedals* " – refer to Page 3-4 of the B3/C3 service manual.

For those who are equipped with frequency-meters or scopes with built-in frequency counters, the frequency of each note has been also added at each TWG terminal.

This article is mainly focused on correct 'Re-wiring' after maintenance intervention on keyboards. Dismounting of keyboards are not covered in this article.
(as an example, refer to <http://b3world.com/hammond-techinfo3.html> - § 5-78).

An adequate technical expertise is compulsory. So this article is mostly addressed to qualified technicians endowed with sufficient know-how, dexterity and ... patience.

(*) TWG : Tone-Wheel Generator

2. TWG to keyboards wiring concept.

When referring to the Wiring Diagram Fig.4-1 of the B3/C3 service manual, we may notice that terminals of TWG are arranged in a certain order that depends of the TWG tone-wheels organization defined by Mr.Laurens Hammond himself.

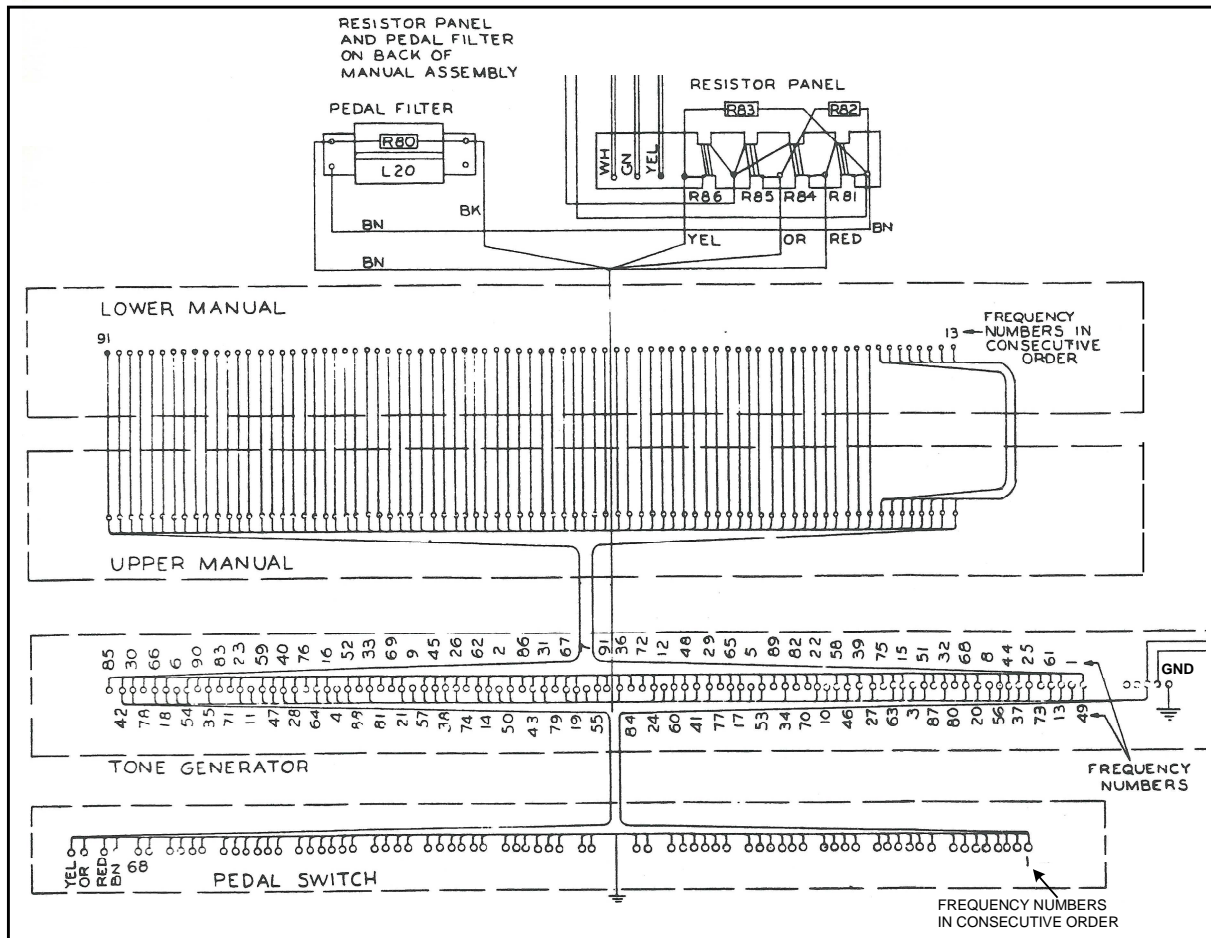

Extracted from B3/C3 service manual - wiring diagram Fig.4-1

Let's put the attention on the above schematic diagram (simplified) that is composed of four main 'blocks' and the top section represents the Resistor Panel and Pedal Filter.

The Lower and Upper manual blocks are simply 'parallel linked'. This means 'point-to-point' connections. Not so much to tell about that. It has to be mentioned that frequency numbers have to be connected in consecutive order from Note # 13 up to Note # 91. The point is : 'Why to start at Note # 13 ?'.

Good question indeed. The reason is that Frequency Numbers from Note # 1 up to Note # 12 are the fundamental notes only connected to the pedal keyboard (i.e. one octave lower than those of Upper and Lower keyboards).

The output signals from the Tone Generator (TWG) block are located on 4 bakelite strips composed of 24 terminals each (see picture on covering page). Each terminal is feeding either all keyboards or only the pedal keyboard. Depending of its Note Number assignment.

The lower block represents the Pedal Keyboard on which only 68 frequency numbers are assigned. In addition to those 68 connections, on the left-end side, 4 coloured wires + 1 black wire are connected to the resistor panel and pedal filter as follows :

- Yellow : 10th and 12th harmonics
- Orange : 6th and 8th harmonics
- Red : 2nd and 4th harmonics
- Brown : Fundamental and 3rd harmonics
- Black : ground

Here again, the frequency numbers are connected in consecutive order from Note # 1 up to Note # 68.

For easiness of understanding, several tables have been prepared as follows :

Table # 1 – Legend (or glossary).

This sketch is simply drawn to become familiarized with annotations of the two subsequent tables. The first bakelite strip (left side of TWG) is composed of 24 terminals numbered from '1' to '24'. The next strip will start at '25' up to '48', and so on up to '96'.

The reference of Hammond Note Nbr is placed on top of each of those terminals.

This Hammond Nbr has been assigned arbitrarily by Hammond engineers for industrial convenience and, in fact, is hiding the exact frequency from each tone-wheel.

On the connecting cable itself, two additional elements are added :

- in blue inked, the reference of the key of the keyboard.
- in red inked, the frequency generated by the corresponding tone-wheel.

The little "  " depicts a spacing of cables lacing. This reference is extremely important for correct re-wiring process. Spacing is available when there is no connection on the relevant terminal. As an example, there is no connection to upper and lower keyboards at terminal # 7 of the bakelite strip, then a spacing is put to bypass this unused TWG terminal for the upper and lower keyboards.

Same for terminal #14 and terminal #22....

Cabling to pedal keyboard are located on the bottom side of bakelite terminal strips.

Table # 2 : Wiring to Upper and Lower Keyboards.

This table represents the overall wiring scheme from TWG to both Upper and Lower keyboards. Most important ground points of the whole organ are brought together at terminals #94 to #96.

Table #3 : Wiring to Pedal Keyboard.

This table represents the overall wiring scheme from TWG to the pedal keyboard.

Only the fundamentals notes (25 in total) are shown. The harmonics are not included but can be easily found (if needed...) with indications on Table # 2.

Appendix # 1 : Hammond Note Nbr / 'Key' Ref / Related frequency.

This table is provided to get a better relation between the Hammond Note number, the effective key on keyboard and subsidiarily the associated frequency.

3.1 **Table # 1 – LEGEND (glossary).**

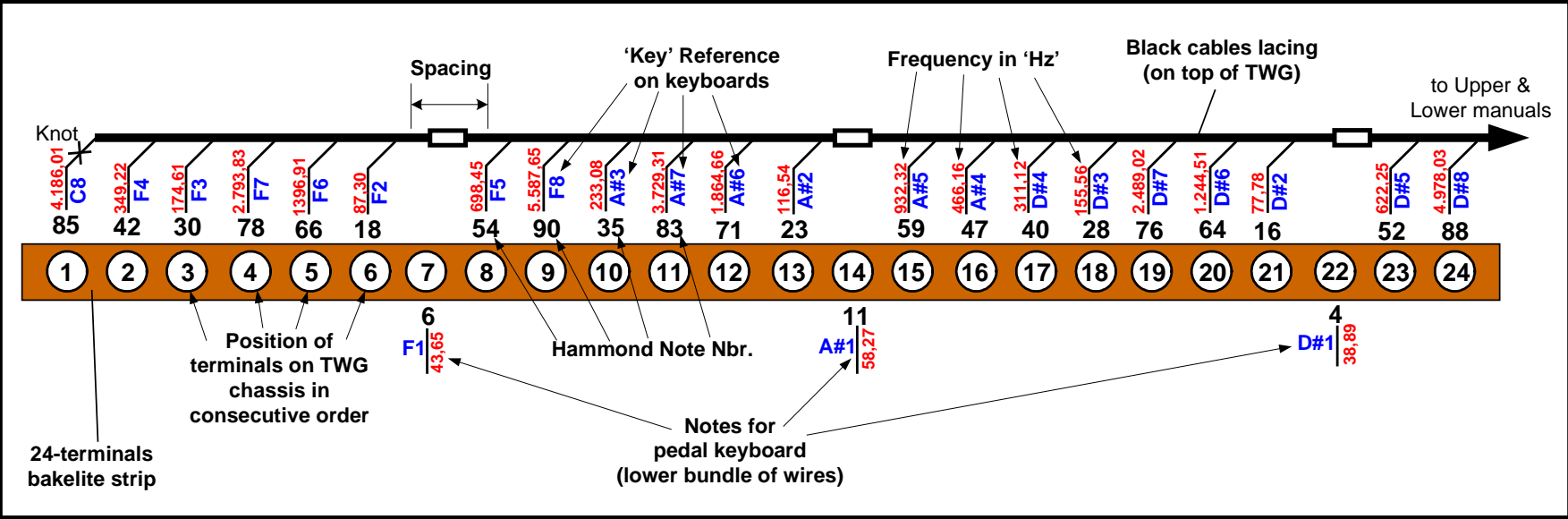

3.2 Table # 2 : Wiring to Upper and Lower Keyboards.

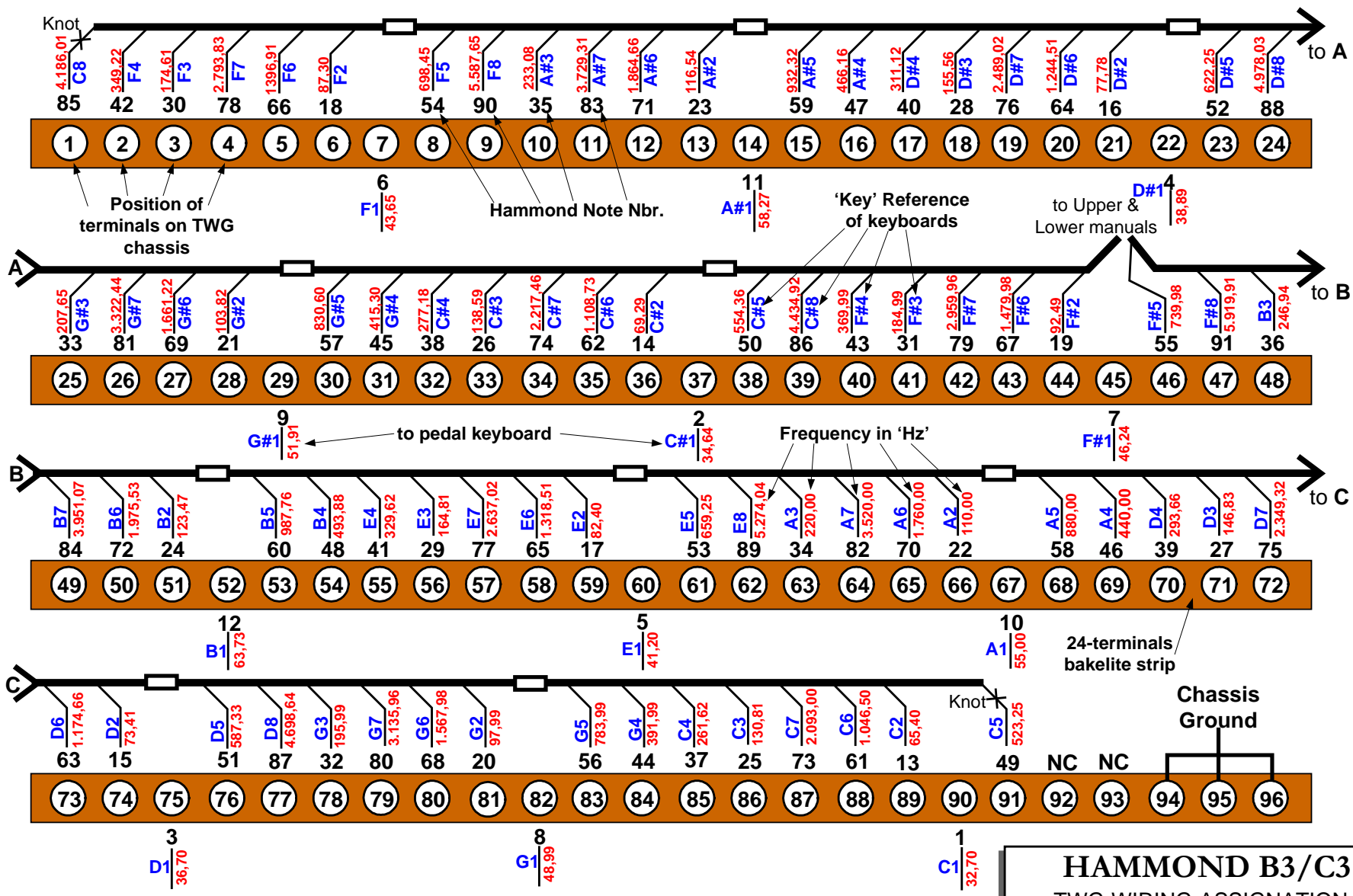

HAMMOND B3/C3
 TWG-WIRING-ASSIGNATION
 Issued by : Dan.Vigin
 File.: TWG_Wiring_Assignation.vsd

Wiring to upper & lower keyboards

NC = No Connection

Hammond(R) and Leslie(R) are registered trademarks of Suzuki Musical Instrument Manufacturing Co. Ltd.

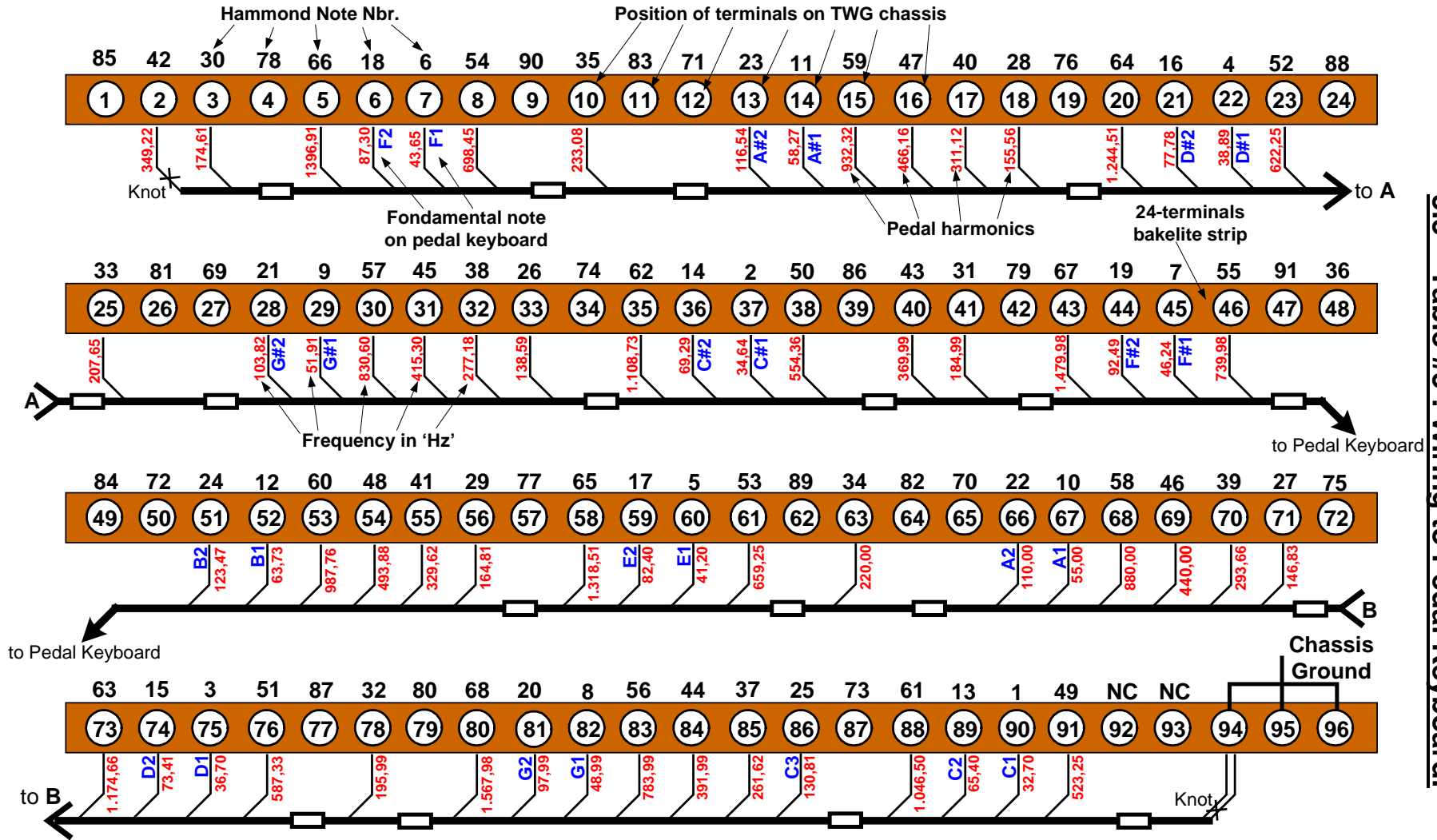

NC = No Connection

Hammond(R) and Leslie(R) are registered trademarks
of Suzuki Musical Instrument Manufacturing Co. Ltd.

Wiring to pedal keyboard

**HAMMOND B3/C3
TWG-WIRING-ASSIGNATION**

Issued by : Dan.Vigin
Date : 15.04.08

File.: TWG_Wiring_Assignation.vsd

3.3 Table #3 : Wiring to Pedal Keyboard.

4. Another way to proceed.

For those who found the above method too complicated, there is another way to cope with TWG re-wiring. The next picture is self-explanatory.

Before unsoldering, just tie up a little sticky label (or the like) with the reference number of the corresponding TWG terminal.

This way was previously experimented as well and has been proved also effective.

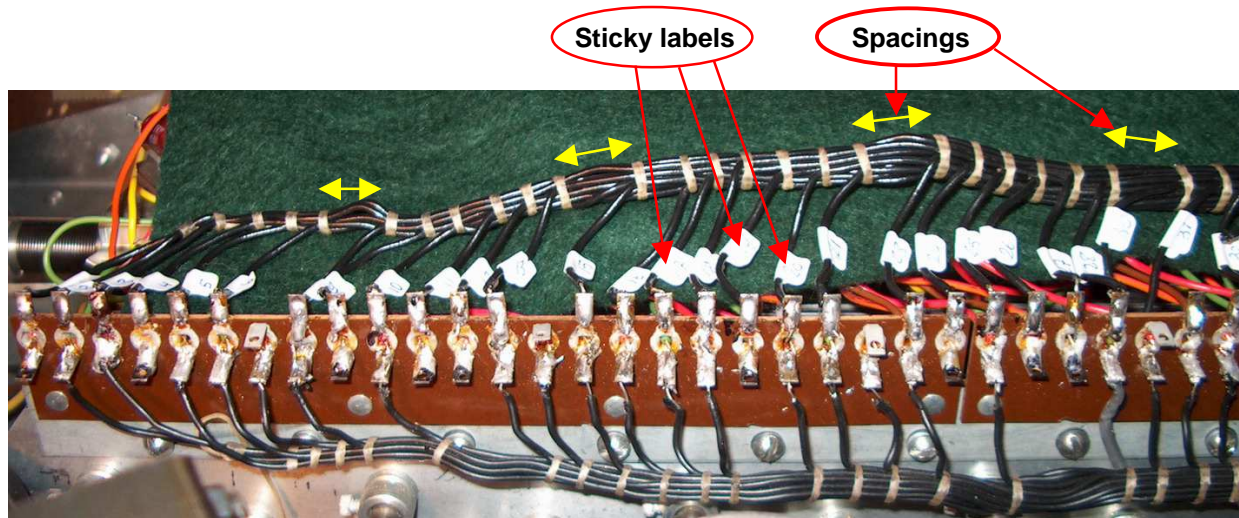

5. Other surrounding wirings.

As stated in the introduction, this article is mostly focused on TWG wiring and it is obvious that whenever keyboards have to be removed from the cabinet, in addition to TWG wiring, there are a lot of other cables to be dismantled (scanner, vibrato line box, resistor panel, AO-28 preamp, etc...).

However, those cables are easily identified since either shielded or coloured.

Before unsoldering, it is highly recommended to take due note of the exact initial location of each cable.

Taking close-up pictures is a good idea, also advisable and often very useful. Remember, no room for wiring error !

6. My conclusion.

The purpose of this article is to provide a reference tool when removing keyboards from the B3/C3 cabinet. Evidently, it has been written based on my own instruments with S/N above 56000. Minor discrepancies in wiring scheme may arise and have to be taken into consideration for lower S/N ranges. Refer to B3/C3 service manual.

Trust having been of some help.

Dan.

Sources :

- Hammond Service Manual B3/C3
- DVD of Alain Kahn ' Hammond Inside ' – Part One
- <http://b3world.com/hammond-techinfo3.html> - § 5-78

Disclaimer :

This information is simply for educational purposes only and no claims are made that this information will lead to any successful repair. Dan Vigin assumes no responsibility to its use.

Appendix # 1 : Hammond Note Nbr / 'Key' Ref / Related frequency.

<u>B3/C3 Key Nbr & Frequency Assignment .</u>								
Hammond	'Key' Ref.	Frequency	Hammond	'Key' Ref.	Frequency	Hammond	'Key' Ref.	Frequency
Note Nbr.		in Hz.	Note Nbr.		in Hz.	Note Nbr.		in Hz.
1	C1	32,7032	37	C4	261,626	73	C7	2.093,00
2	C#1	34,6478	38	C#4	277,183	74	C#7	2.217,46
3	D1	36,7081	39	D4	293,665	75	D7	2.349,32
4	D#1	38,8909	40	D#4	311,127	76	D#7	2.489,02
5	E1	41,2034	41	E4	329,628	77	E7	2.637,02
6	F1	43,6536	42	F4	349,228	78	F7	2.793,83
7	F#1	46,2493	43	F#4	369,994	79	F#7	2.959,96
8	G1	48,9994	44	G4	391,995	80	G7	3.135,96
9	G#1	51,9131	45	G#4	415,305	81	G#7	3.322,44
10	A1	55,0000	46	A4	440,000	82	A7	3.520,00
11	A#1	58,2705	47	A#4	466,164	83	A#7	3.729,31
12	B1	63,7354	48	B4	493,883	84	B7	3.951,07
13	C2	65,4064	49	C5	523,251	85	C8	4.186,01
14	C#2	69,2957	50	C#5	554,365	86	C#8	4.434,92
15	D2	73,4162	51	D5	587,330	87	D8	4.698,64
16	D#2	77,7817	52	D#5	622,254	88	D#8	4.978,03
17	E2	82,4069	53	E5	659,255	89	E8	5.274,04
18	F2	87,3071	54	F5	698,456	90	F8	5.587,65
19	F#2	92,4986	55	F#5	739,989	91	F#8	5.919,91
20	G2	97,9989	56	G5	783,991			
21	G#2	103,826	57	G#5	830,609			
22	A2	110,000	58	A5	880,000			
23	A#2	116,541	59	A#5	932,328			
24	B2	123,471	60	B5	987,767			
25	C3	130,813	61	C6	1.046,50			
26	C#3	138,591	62	C#6	1.108,73			
27	D3	146,832	63	D6	1.174,66			
28	D#3	155,563	64	D#6	1.244,51			
29	E3	164,814	65	E6	1.318,51			
30	F3	174,614	66	F6	1.396,91			
31	F#3	184,997	67	F#6	1.479,98			
32	G3	195,998	68	G6	1.567,98			
33	G#3	207,652	69	G#6	1.661,22			
34	A3	220,000	70	A6	1.760,00			
35	A#3	233,082	71	A#6	1.864,66			
36	B3	246,942	72	B6	1.975,53			