

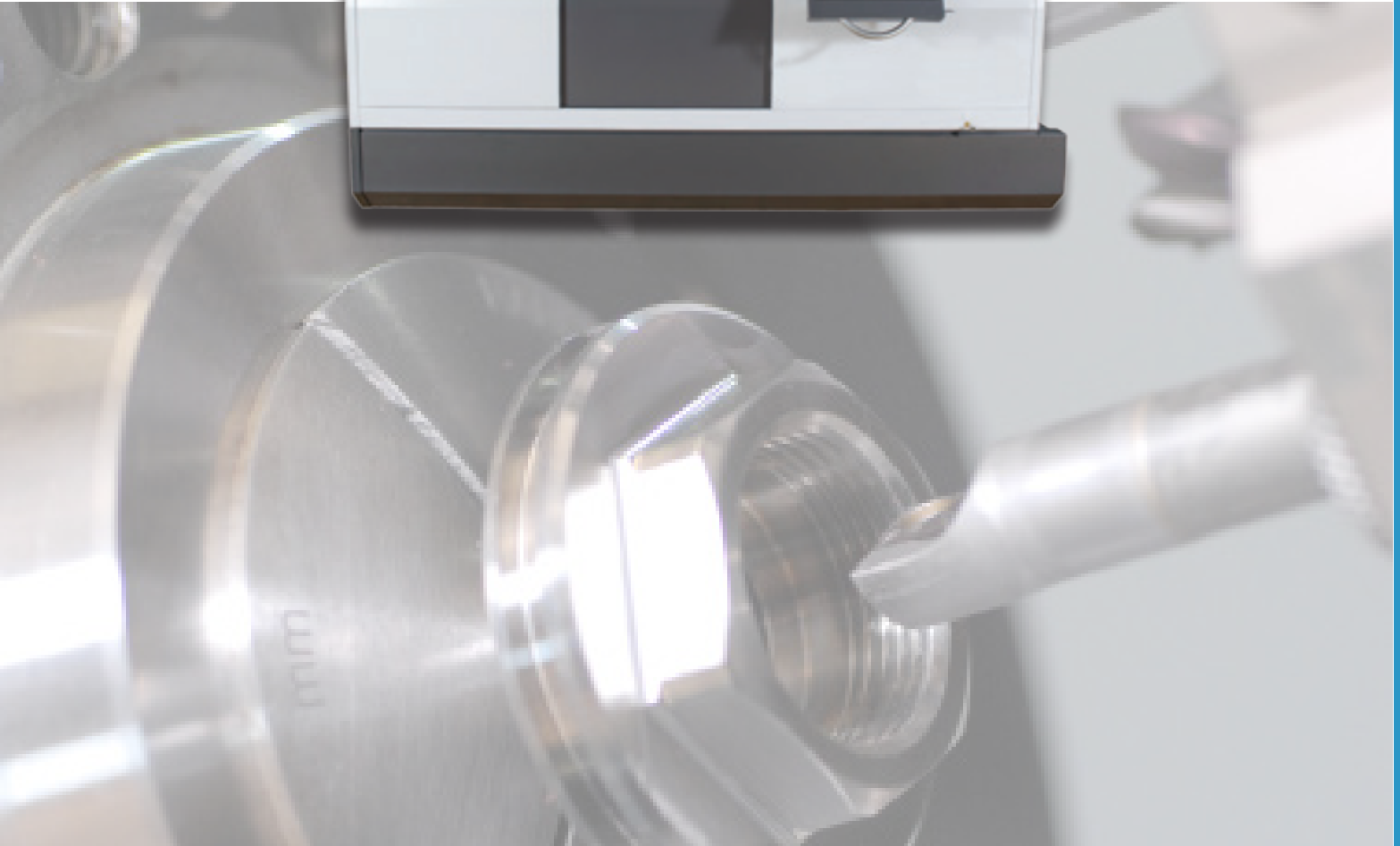

TURNING

HARDINGE  
T-Series  
SUPER-PRECISION®  
Turning Centers

COLLET-READY  
SPINDLE



[www.hardinge.com](http://www.hardinge.com)



As the worlds only SUPER-PRECISION® turning center, Hardinge's T-Series is the industry leader in accuracy

## Summary of SUPER-PRECISION® Results

Machine Model: SUPER-PRECISION® T-42

Test Part 62 Rc 8620 Steel

- |  |                        |
|--|------------------------|
| (1) Cylindricity:                          | 0.000025"              |
| (2) Maintaining a Profile - 3 Small Steps: | 0.000050" +/- 0.000010 |
| (3) Maintaining a Profile - 200" Arc:      | +/- 0.000030"          |
| Surface Finish:                            | 6 micro-inch           |
| Small Step Test:                           | .0000080" +/- 2 steps  |

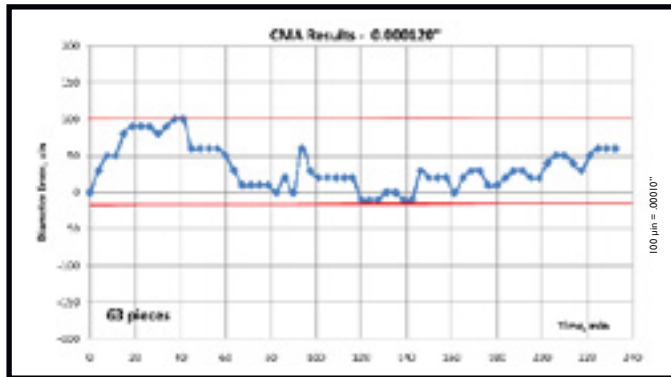
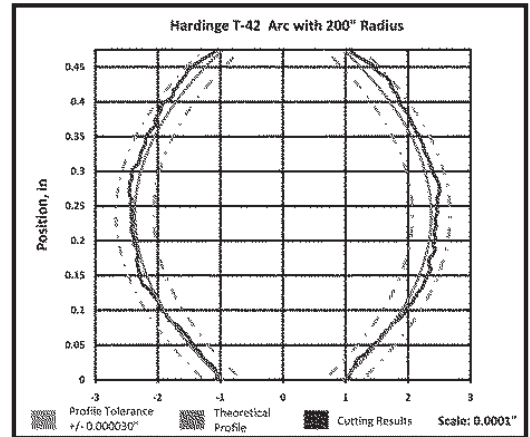
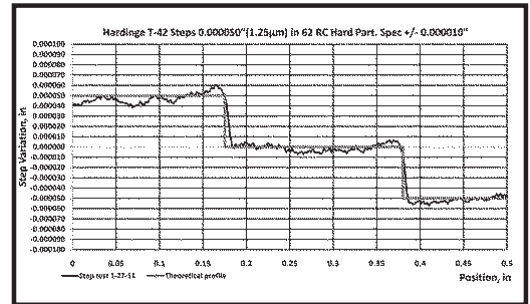
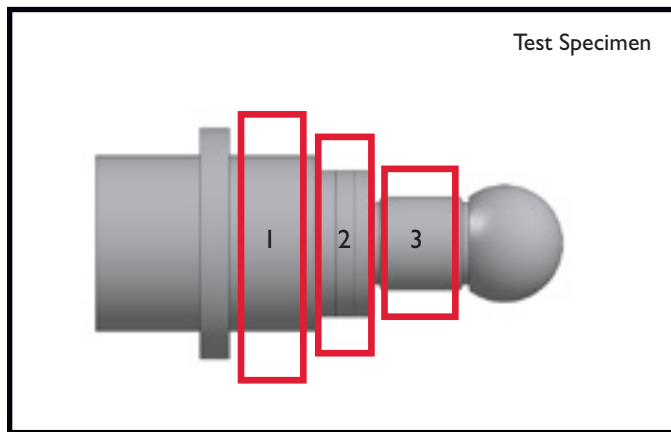
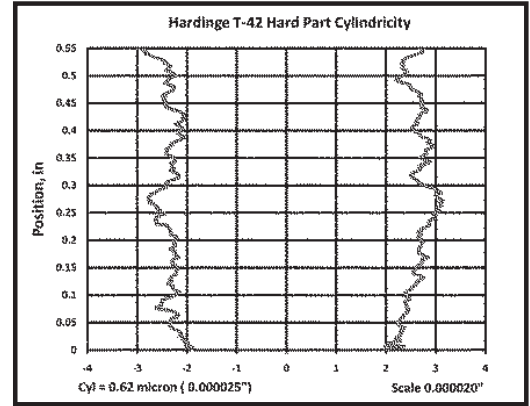

## Continuous Machining Accuracy Cutting Conditions:

- CMA Results: 0.00012"
- Cycle Time: 3min. 20 sec.
- Spindle Speed: 1200 RPM
- Cutting Depth: .005"
- Feedrate: .005 IPR
- Material: Brass
- Coolant Chiller: Yes

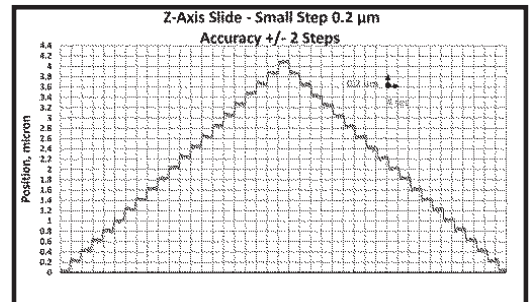

\*Actual results may be greater or less than those listed due to a number of factors including but not limited to warm up cycles, speeds, feeds, tooling, machine maintenance, coolant, material, ambient temperature and type of machine foundation.

# Precision for the highest demand

## Standard Specifications

T-42 M T MT MY MYT S MS MSY

- Spindle Nose: A2-5 / 16C (A2-6 / 20C Big Bore Option)
- Collet Capacity (in/mm): 1.625 / 42 (2 / 51 Big Bore Option)
- Spindle Through Hole (in/mm): 1.890 / 48
- Chuck Size (Chuck not Included) (in / mm): 6 / 150
- Spindle Motor (hp / kW): 15 / 11
- Max Spindle Speed (rpm): 6,000 (5,000 Big Bore Option)
- Number of Turret Stations (BMT-45 / block type): 16 / 12
- CNC Control: Fanuc 31i



## Standard Specifications

T-51 M T MT MY MYT S MS MSY

- Spindle Nose: A2-6 / 20C
- Collet Capacity (in / mm): 2 / 51
- Spindle Through Hole (in / mm): 2.378 / 60.04
- Chuck Size (Chuck not included) (in / mm): 8 / 200
- Spindle Motor (hp / kW): 20 / 15
- Max Spindle Speed (rpm): 5,000
- Number of Turret Stations (BMT-55 / block type): 12 / 12
- CNC Control: Fanuc 31i



## Standard Specifications

T-65 M T MT MY MYT S MS MSY

- Spindle Nose: A2-6 / 25C
- Collet Capacity (in/mm): 2.5 / 65
- Spindle Through Hole (in/mm): 2.935 / 75
- Chuck Size (Chuck not Included) (in/mm): 10 / 250
- Spindle Motor (hp/kW): 35 / 26
- Max Spindle Speed (rpm): 4,000
- Number of Turret Stations (BMT-55 / block type): 12 / 12
- CNC Control: Fanuc 31i



# Machine Construction

The Hardinge T-Series turning centers and SUPER-PRECISION® T-Series turning centers set the standard in high-precision and high-performance turning that will take your part quality and manufacturing capabilities to new heights. T-Series machines are designed to exceed your expectations and are ideal for two axis high-precision machining or complex multi-tasking operations that require a high level of precision, delicate part handling and for parts made complete in a single setup. Machine packages are pre-configured with our most popular features allowing you to select the proper machine tool configuration to produce your parts in the most effective and profitable manner.

Heavy duty integral motor spindle design for enhanced thermal stability.

Heavy duty FANUC motor and drives.

Hardinge's unique collet-ready spindle.

Independent Y-Axis for superior part accuracy.

Heavy duty liner roller guides on E-Axis for optimum stiffness, rigidity, accuracy and longer life.

Strategically ribbed HARCLETE® reinforced 45 degree cast base iron base.

Hardinge BMT or Hardinge T-Style top plate.

High class linear ball guides on X,Y,Z Axes for higher accuracy, faster traverse rates, less wear, and longer life.

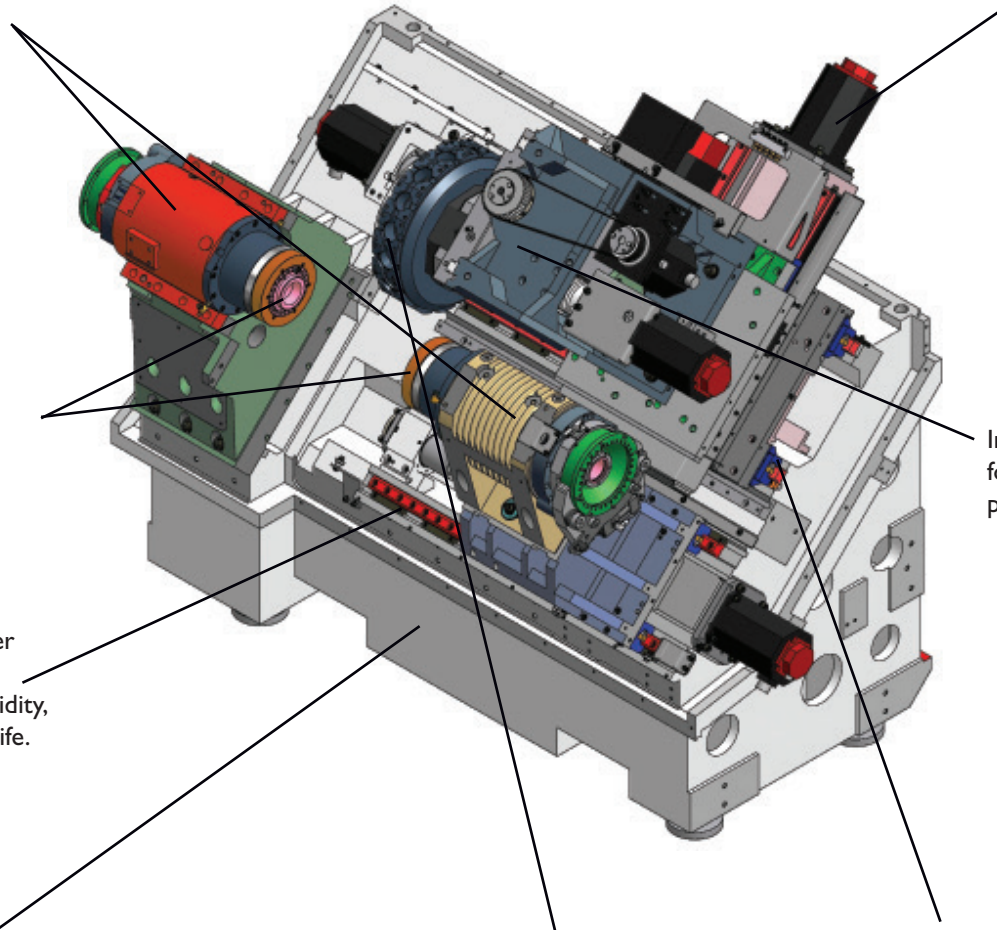



## Exclusive collet-ready spindle

Increased concentricity, surface finish capability, superior roundness, and fast job change over

The preferred method of holding a workpiece for precision machining is with a collet. The Hardinge designed and built ANSI collet-ready spindle permits the industry's best part rigidity, since parts are gripped closest to the spindle bearings. Ask for "The Hardinge Advantage" Technical Information Bulletin TIB-229.

## Heavy-duty linear guideways, ballscrews and axis drives

Faster traverse rates, longer machine life and greater positioning accuracy

Wide-spaced, size 35mm (T-42), 45mm (T-51 and T-65) linear guideways provide optimum stiffness with less friction, less heat and less thermal growth. The linear way modules consist of slide members (guide trucks) and linear rails to provide a large load rating, stable accuracy, high rigidity and low friction.

## Rigid machine base

Finer surface finishes and 30% longer tool life

The rugged cast iron base with HARCURET<sup>®</sup> polymer composite (synthetic granite) reinforcement offers added stiffness with superior vibration damping characteristics, resulting in extended tool life.

## Linear glass scale

High machining accuracy and repeatability

The Heidenhain closed-loop linear scale system on the X,Y,Z axes provide direct measurement to compensate for any ballscrew thermal growth and wear ensuring highest accuracy through the most demanding duty cycles and over the life of the machine.

\* x-axis standard and z-axis optional on HP models

## Heavy duty servo-driven tailstock

Maximum flexibility

Our servo tailstock features fully programmable axis speed control, positioning and force, controlled through the part program, allowing fast approach/retract speed, multiple positioning capability and force control. This allows for precise part engagement and applied force. The result is reduced overall operating time when compared to hydraulic tailstock systems by over 20%, while increasing part quality.

## Hard Turn instead of grind

Reducing manufacturing costs

Hardinge is the recognized market leader in providing "hard turning" machines, workholding and process support. SPC (statistical process control) for size repeatability, surface finish quality and thermal stability is a hallmark for T-Series turning centers which are built and tested to ensure "in-tolerance" parts and surface finishes with predictable tool wear. T-Series machines are also ideally suited for hard milling applications.

- "Soft turn" and "hard turn" on the same machine
- Less floor space requirement
- Lower overall investment
- Metal removal rates of 4 to 6-times greater
- Eliminate Operations
- Multiple operations in a single setup
- Finer micro finishes
- Easier Part configuration changes
- Lower cost tooling inventory
- Easier waste management (chips vs. "swarf")

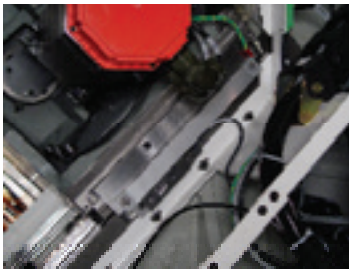

# Turret & Top Plate

The exclusive Hardinge BMT-45 and BMT-55 turret top plate and tooling system is featured on T-Series turning centers. You can also choose a Hardinge T-style top plate for static tooling compatibility with QUEST® and CONQUEST® T42/T51/T65 lathes equipped with a T-style top plate. (T-42 includes BMT-45, 16 Station; T-51 and T-65 include BMT-55, 12 Station)

The Hardinge BMT-45 Live Tooling Top Plate with Tenon tool drive system provides 16 live tooling stations with 1/2 station index between each station providing 32 stations. The Hardinge BMT-55 has 12 and 24 station respectively.

Both the static and live tool holders are designed to adapt modular add-on tool holder blocks providing the ultimate in overall tooling flexibility.



The unique Hardinge BMT system also allows fine adjustment of tools in the Y-axis plane for machines without a true Y-axis for pinpoint tool alignment. Our tooling system is keyed for precision and provides unparalleled station to station tooling accuracy and repeatability.

Live tool holders start at 8,000-rpm and are capable of up to 16,000 or 32,000-rpm when purchased with ratios of 2:1 or 4:1 when high speeds are required. The Hardinge BMT live tooling holders provide superior run-out within .00012" (3 micron) making it the overall best in class tooling system.

T-Style Tooling Layout

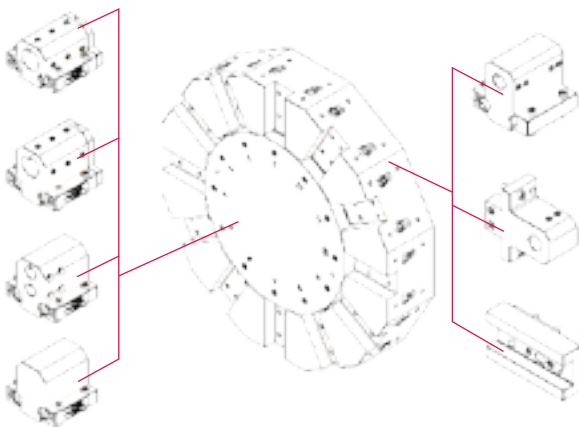

BMT - 45 Top Plate

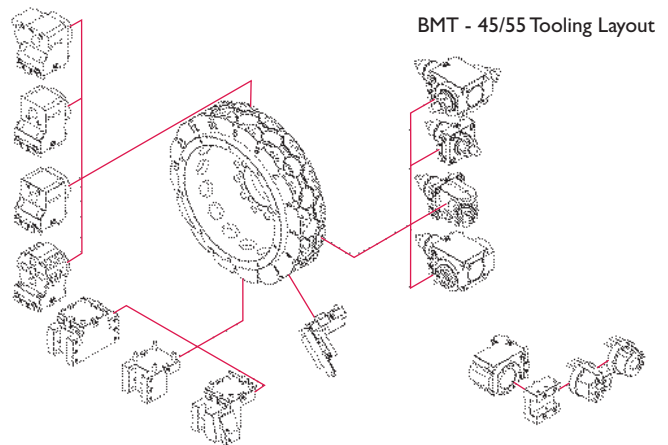

BMT - 45/55 Tooling Layout

T-Style Top Plate

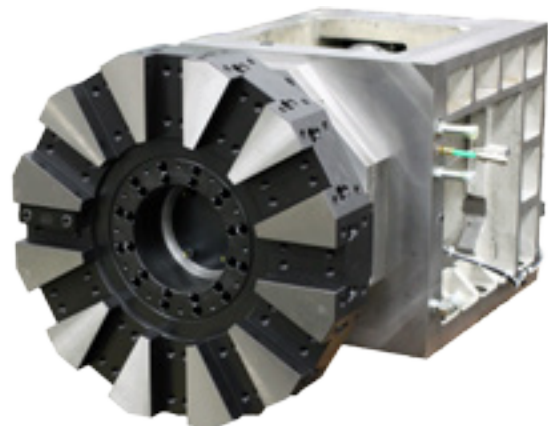

## Main and Sub-Spindle Tooling for Hardinge® T-Series Horizontal Turning Centers

Hardinge collet-ready spindles accept standard 16C, 20C or 25C tooling to offer a wide range of workholding options. Not to mention other workholding alternatives with either A2-5 or A2-6 spindle adapters, such as chucks and adaptation chucks.



T-Series Horizontal Turning Centers Spindle	T-42 Primary A2-5 Spindle & Sub	T-51 Primary A2-6 Spindle	T-65 Primary A2-6 Spindle	T-51/65 Sub-Spindle A2-6 Spindle
Workholding Options:				
Collets (maximum capacities)	16C	20C	25C	20C
Round-smooth & serrated	1-5/8"	2"	2.559"	2"
Hex-smooth	1-13/32"	1-3/4"	2.216"	1-3/4"
Square-smooth	1-9/64"	1-27/64"	1.808"	1-27/64"
Collet Stops	Solid, Long, Ejector, Universal	Solid, Ejector	Solid	Solid, Ejector
Emergency Collet (pilot hole size)	1/4", 1/16", 1/8", none	1/4" and none	1/2" and none	1/4" and none
Extended-Nose Emergency Collet (ext. length)	1/2" and 1"	3/4" and 1-1/2"	—	3/4" and 1-1/2"
FlexC™ Collet Systems (max. capacities)	42mm	65mm	65mm	65mm
Round-Smooth & serrated	1-5/8"	2-9/16"	2-9/16"	2-9/16"
Hex-Smooth	1-3/8"	2-1/8"	2-1/8"	2-1/8"
Square-Smooth	1-9/64"	1-13/16"	1-13/16"	1-13/16"
Master Collets & Pads-Style "S" (maximum round capacities)	S12: 1-1/4", S16: 1-5/8"	S20-2"	S26: 2-5/8"	S20-2"
Sure-Grip® Expanding Collet System (capacity)				
Collet-Style	1/2" to 4"	—	—	—
Spindle-Mount Style	1/8" to 4"	1" to 4"	1" to 4"	1" to 4"
Master Expanding Collets - emergency pads	1/4" to 3"	—	—	—
Step Chucks & Closers - Emergency Style *				
Regular-Depth Emergency (max. dia./depth)	2" to 6" / 1/2"	—	—	—
Extra-Depth Emergency (max. dia./depth)	2" to 6" / 1-1/4"	3" to 6" / 1-1/4"	4" - 8" / 1-3/4"	3" to 6" / 1-1/4"
Force-Limiting Step Chuck	on application	on application	on application	on application
Dead-Length Control - Emergency Style *				
Collet (max. diameter bore)	1-13/32"	—	—	—
Thru-hole Collet (max. round capacity)	1-3/16"	—	—	—
Step Chuck (max. diameter bore)	2-3/4"	3-1/2"	—	3 1/2"
Spider-Stop Step Chuck (max. diameter bore)	3", 4"	—	—	—
Sure-Grip® 3-Jaw Power Chuck (diameter)	6" std, 5" & 8" opt.	8" std, 6" & 10" opt.	10" std, 8" opt.	8" std, 6" & 10" opt.
Headstock Centers	YES	YES	YES	YES
Spindle Adapters	16C to 5C 16C to #22 B&S	20C to 16C	25C to 16C	20C to 16C
Fixtures				
Spindle-Mount Style	5-1/2", 8-7/8"	—	—	—
Collet-Style	6-3/8"	—	—	—

\* also available hardened and ground

# Spindle Tooling

## Take your Hardinge collet-ready spindle lathe to the limit using flexible workholding options...

Hardinge is unique as a machine tool builder — we manufacture our own workholding products. Precision and accuracy is yours when you use Hardinge perfectly-mated workholding products.



### Collets

Hardinge hardened and ground collets are inspected and measured in a Hardinge Super-Precision® spindle. Collets are available in fractional round, hex and square sizes and round metric, as well as round serrated fractional and metric sizes. Use adjustable, machinable collet stops for accurate part positioning.



### Emergency Collets

Emergency collets have a soft face with a pilot hole for customer drilling, boring and stepping out to the exact size required. An optional extended nose permits deeper counterbores when required and tool clearance for extended work.

### FlexC™ Quick-Change Vulcanized Collet Systems

Interchangeable quick-change vulcanized collet heads have a working range of  $\pm 0.020$ " (0.5mm) to accept bar stock variation. Collets change in seconds, while accuracy is maintained at  $.0004$ " (.010mm).



### Style "S" Master Collets and Pads

Pads can be changed much quicker than solid collets can. Pads cost less and use less storage space when compared to a standard solid collet. Choose from hardened and ground, semi-hard and emergency pads. Styles S16, S20 and S26 require a collet closer.

### Sure-Grip® Expanding Collet Systems

The Hardinge Sure-Grip expanding collet provides high-precision, internal gripping solutions with true parallel gripping. Collet-style and spindle-mount styles are available, depending on the machine model.



Master Expanding Collets are a lower-cost alternative to Sure-Grip Expanding Collet Systems and include a dead-length feature.

### Step Chucks and Closers

Step Chucks and closers are used to accurately hold larger diameter parts.



### Force-Limiting Step Chuck

The Hardinge force-limiting step chuck has built-in force control to safely grip thin-wall parts. Maintain inside and outside concentricity in a fail-safe process while eliminating the nuisance of manually tweaking the draw bar.



### Dead-Length® Systems

Maintain part-length control by using Hardinge dead-length systems. Choose from dead-length collet assemblies, thru-hole collets, step chucks and spider-stop step chucks. 16C to #22 B&S adapter shown on A2-5 sub-spindle.



### 3-Jaw Power Chucks

Hardinge power chucks are lever operated, counter-centrifugal and dynamically balanced. Quick-change chucks are also available.





## Fanuc 3i Control

### General

- Pendant-mounted Full Control
- 10.4" LCD Display
- Graphic Display
- Embedded Ethernet
- RS-232C Communication Ports
- Program Resolution .00001" (.0001mm)
- Tool Offset Capability .00001" (.0001mm)
- Tool Offsets with Geom/Wear (99)
- Tool Offsets with Geom/Wear (200/400)
- Absolute Encoders
- Inch/Metric Selection by G-Code
- 160 Meters (64Kbyte) Part Program Storage
- Part Program Storage (128/256/512KB, 1/2/4MB)

### Programming Functions

- Absolute/Incremental Programming
- Additional Custom Macro Variables
- Alarm Display
- Auto Acceleration/Deceleration
- Auto Coordinate System Setting
- Background Editing
- Canned Cycles (Drilling)
- Chamfer/Corner Rounding
- Circular Interpolation by R Programming
- Constant Surface Speed Programming
- Continuous Thread Cutting
- Coordinate System Setting (G50)
- Custom Macro B
- Decimal Point Programming
- Diameter/Radius Programming
- Direct Drawing Dimension Programming
- Display Position, Program, Alarm, History
- Extended Part Program Edit (copy/replace)
- External Workpiece Number Search
- Hardinge Safe Start Format
- Helical Interpolation (for Y-Axis)
- Helical Interpolation (for Non - Y-Axis)
- Help Screen
- Input of Offset Values by (G10)
- Interpolation (Linear/Circular)
- MPG Manual Pulse Generator
- Manual Guide i with full color display
- Multiple Repetitive Cycles I (Turning)
- Multiple Repetitive Cycles II (Pocketing)
- Multi Spindle Control
- Program Number Search
- Programmable Parameter Input
- Reference Point Return
- Registered Part Program Storage (125)
- Rigid Tapping

- Standard
- Option



- Spindle Orient Main & Sub (Std. on Live Tooling Models)
- Spindle Synchronization (Main & Sub)
- Sequence Number Search
- Single Block Operation
- Skip Function G31
- Stored Stroke Check 2 & 3
- Sub Program Call (10 fold nested)
- Thread Cutting Retract
- Thread Cutting
- Tool Life Management (32 Pair)
- Tool Life Management Offset Pair (64/240)
- Tool Nose Radius Compensation (Geom/Wear)
- Variable Lead Thread Cutting
- Workpiece Coordinate System (G52-G59)
- Miscellaneous
- Actual Cutting Speed and T-Code Display
- Dual Check Safety (Spindle Speed)
- English
- French/German/Italian/Spanish Language
- Chinese in Fanuc menus only
- Flash Card Capability PCMICA (up to 1-GB)
- Floating Reference Point Return
- Full Keyboard
- Ladder Diagram Display
- Mechanical Run Meter



# Specifications

	T-42	T-51	T-65
<b>Swing Diameter</b>			
Maximum Swing Over Way Covers	27" (685.8mm)	26.5" (673mm)	26.5" (673mm)
<b>Work Capacities</b>			
Chuck Size	6" (150mm)	8" (200mm)	10" (250mm)
Maximum Bar Capacity	1.625" (42mm)	2" (51mm)	2.5" (65mm)
Maximum Machining Diameter (BMT)	8.91" (226.3mm)	12.35" (313.7mm)	12.35" (313.7mm)
Maximum Machining Diameter (T-Style)	12.4" (315mm)	15.245" (387.2mm)	15.245" (387.2mm)
Max. Machining Length w/Tailstock BMT	14.2" (360.6mm)	22.47" (570.7mm)	22.47" (570.7mm)
Max. Machining Length w/Tailstock Hardinge T-style	13.63" (346.2mm)	23.6" (599.4mm)	23.6" (599.4mm)
Max. Machining Length w/Chuck BMT	8.478" (215mm)	16.85" (428mm)	15.70" (398.65mm)
Max. Machining Length w/Chuck Hardinge T-Style	9.125" (231.8mm)	17.99" (456.8mm)	16.83" (427.36mm)
<b>Main Spindle</b>			
Maximum Speed	6000-rpm	5000-rpm	4000-rpm
Maximum Power Rating (Continuous)	15-hp (11 kW)	20-hp (15 kW)	35-hp (26 kW)
Maximum Torque (Continuous)	108 ft-lb (146.3 Nm)	256 ft-lb (347 Nm)	311 ft-lb (421 Nm)
Base Speed	750-rpm	420-rpm	590-rpm
Spindle Nose	A2-5 / 16 C	A2-6 / 20 C	A2-6 / 25 C
Chuck Size (Chuck Not Included)	6" (150 mm)	8" (200 mm)	10" (250 mm)
Spindle Bore (not bar capacity)	1.89" (48mm)	2.378" (60.4mm)	2.935" (75mm)
Spindle Center Height	42" (1066.8mm)	42" (1066.8mm)	42" (1066.8mm)
Spindle Reach	16" (406.4mm)	17.5" (444.5mm)	17.5" (444.5mm)
Spindle Orient (optional)	1.0 degree	1.0 degree	1.0 degree
Closer Type	Hydraulic	Hydraulic	Hydraulic
Maximum Hang Weight	100 lbs. (45.3kg)	300 lbs. (136kg)	300 lbs. (136kg)
<b>Sub Spindle</b>			
Maximum Speed	6000-rpm	5000-rpm	5000-rpm
Maximum Power Rating (Continuous)	15-hp (11 kW)	15-hp (11 kW)	15-hp (11 kW)
Maximum Torque (Continuous)	108 ft-lb (146.3 Nm)	108 ft-lb (146.3 Nm)	108 ft-lb (146.3 Nm)
Base Speed	750-rpm	750-rpm	750-rpm
Spindle Nose	A2-5 / 16 C	A2-6 / 20 C	A2-6 / 20 C
Chuck Size (Chuck Not Included)	6" (150 mm)	6" (150 mm)	6" (150 mm)
Spindle Bore (not bar capacity)	1.89" (48mm)	2.378" (60.4mm)	2.378" (60.4mm)
Spindle Center Height	42" (1066.8mm)	42" (1066.8mm)	42" (1066.8mm)
Spindle Reach	16" (406.4mm)	17.5" (444.5mm)	17.5" (444.5mm)
Spindle Orient (optional)	1.0 degree	1.0 degree	1.0 degree
Closer Type	Pneumatic	Pneumatic	Pneumatic
Maximum Travel	16" (406.4mm)	25.125" (638mm)	25.125" (638mm)
Maximum Traverse Rate	1200-ipm (30.5m/min)	1500-ipm (38m/min)	1500-ipm (38m/min)
Max. Distance from Sub to Main Spindle Face	16.5" (419.1mm)	25.75" (654.1mm)	25.75" (654.1mm)
Min. Distance from Sub to Main Spindle Face	.5" (12.7mm)	.625" (15.8mm)	.625" (15.8mm)
Maximum Hang Weight	100 lbs. (45.3kg)	100 lbs. (45.3kg)	100 lbs. (45.3kg)
<b>Travels and Feedrates</b>			
	6.37" (161.8mm)	7.76" (197mm)	7.76" (197mm)
Maximum X-Axis Travel	16" (406.4mm)	25" (635mm)	25" (635mm)
Maximum Z-Axis Travel	3.25" (82.55mm)	3.50" (88.90mm)	3.50" (88.90mm)
Maximum Y-Axis Travel	1,500 lbs. (6,672N)	2,250 lbs (10,008N)	2,250 lbs (10,008N)
Continuous Z-Axis Thrust	945-ipm (24m/min)	1100-ipm (28m/min)	1100-ipm (28m/min)
X-Axis Rapid Traverse Rates	1200-ipm (30.5m/min)	1500-ipm (38m/min)	1500-ipm (38m/min)
Z-Axis Rapid Traverse Rates	500-ipm (12.7m/min)	500-ipm (12.7m/min)	500-ipm (12.7m/min)
Y-Axis Rapid Traverse Rates			
<b>Hardinge BMT Live Tooling Top Plate</b>			
BMT bi-directional	16-station + ½ station index	12-station + ½ station index	12-station + ½ station index
Square Shank	3/4" (20mm)	1" (25mm)	1" (25mm)
Round Shank Tooling	1.25" (32mm)	1.5" (38mm)	1.5" (38mm)
Index Time (rotation/including clamp-unclamp)	1.45 Seconds	.35/1.35 Seconds	.35/1.35 Seconds
Tool Shank Dia. w/ER 25 Collets	.04 - .625" (1mm - 16mm)	.04 - .625" (1mm - 16mm)	.04 - .625" (1mm - 16mm)
Live Tooling Power Rating (30 Min Rating)	7.5-hp (5.5 kW)	10-hp (7.5 kW)	10-hp (7.5 kW)
Live Tooling Torque Rating (30 Min Rating)	25 ft-lb (33 Nm)	31 ft-lb (42 Nm)	31 ft-lb (42 Nm)
Live Tooling Max Speed	8,000-rpm	8,000-rpm	8,000-rpm
<b>Hardinge Block Type (T-Style) Static Top Plate</b>			
Block Type (Static) bi-directional	12-station	12-station	12-station
Square Shank (Left, Right or Inverted Tooling)	3/4" (20mm)	1" (25mm)	1" (25mm)
Round Shank Tooling	1.25" (32mm)	1.5" (38mm)	1.5" (38mm)
Index Time (rotation/including clamp-unclamp)	.35/1.2 Seconds	.35/1.2 Seconds	.35/1.2 Seconds

	T-42	T-51	T-65
<b>Servo Driven Tailstock</b>			
Morse Taper (no quill needed)	MT # 4	MT # 4	MT # 4
Maximum Cutting Length BMT	14.5" (368.3mm)	22.5" (571.5)	22.5" (571.5)
Maximum Tailstock Travel	16" (406.4mm)	23.3" (567mm)	23.3" (567mm)
Maximum Traverse Rate	1200-ipm (30.5m/min)	1500-ipm (38m/min)	1500-ipm (38m/min)
Minimum Applied Force	350 lb. (1.55kN)	370 lb. (1.6kN)	370 lb. (1.6kN)
Maximum Applied Force	1500 lb. (6.7kN)	1599 lb. (7.1kN)	1599 lb. (7.1kN)
<b>Coolant Facilities</b>			
Coolant Capacity	55 gallon (208 liter)	67 gallon (254 liter)	67 gallon (254 liter)
Maximum Pressure	200 psi (13.8 bar)	200 psi (13.8 bar)	200 psi (13.8 bar)
Coolant Flow Rate (Per-Minute)	6.7 gallon (25.4 liters)	6.7 gallon (25.4 liters)	6.7 gallon (25.4 liters)
High Pressure Through Turret (Option)	1,000 psi (68.95 bar)	1,000 psi (68.95 bar)	1,000 psi (68.95 bar)
<b>HIGH-PERFORMANCE Accuracy and Surface Finish Specifications</b>			
Part Surface Finish	12 micro-inch / .30 micron	12 micro-inch / .30 micron	12 micro-inch / .30 micron
Overall Axis Repeatability	.00005" / 1.27 micron	.00005" / 1.27 micron	.00005" / 1.27 micron
Program Resolution (non-SP)	.00001" (.0001mm)	.00001" (.0001mm)	.00001" (.0001mm)
Turret Indexing Repeatability	.000060" / 1.52 micron	.000060" / 1.52 micron	.000060" / 1.52 micron
<b>SUPER-PRECISION® Accuracy and Surface Finish Specifications</b>			
Overall Axis Repeatability (X, Z)	.000030" (.76 micron)	.000030" (.76 micron)	.000030" (.76 micron)
Part Surface Finish	6 micro-inch (.15 micron)	8 micro-inch (.2 micron)	8 micro-inch (.2 micron)
Roundness	.00001" (.25 micron)	.00002" (.5 micron)	.000025" (.625 micron)
Total Variation on Diameter	.00012" (3 micron)	.00012" (3 micron)	.00012" (3 micron)
Program Resolution	.00001" (.0001mm)	.00001" (.0001mm)	.00001" (.0001mm)
Turret Indexing Repeatability	.000060" / 1.52 micron	.000060" / 1.52 micron	.000060" / 1.52 micron
<b>Power Requirements (MSY Configuration)</b>			
Maximum kVA/Full Load Amps	82 kVA/103FLA	89 kVA/112FLA	89 kVA/112FLA
Maximum Voltage/Hz	400/50Hz, 460/60Hz	400/50Hz, 460/60Hz	400/50Hz, 460/60Hz
Phase/Hertz	3-phase/50-60 Hz	3-phase/50-60 Hz	3-phase/50-60 Hz
<b>Miscellaneous</b>			
Machine Lubrication	Grease	Grease	Grease
Machine Communication	RS-232-C, Ethernet	RS-232-C, Ethernet	RS-232-C, Ethernet
Machine Length	98" (2489.2mm)	128.23" (3257mm)	128.23" (3257mm)
Machine Depth	83.5" (2121mm)	91.04" (2312.4mm)	91.04" (2312.4mm)
Machine Height (no stack light)	82.25" (2089mm)	83.6" (2123mm)	83.6" (2123mm)
Approx. Machine Weight	13,100 lb (5940kg)	17,200 lb (7800kg)	17,200 lb (7800kg)
Approx. Shipping Weight	13,600 lb (6170kg)	18,900 lb (8570kg)	18,900 lb (8570kg)
Air Requirement	70 - 90 psi (4.8-6.2 bar)	70 - 90 psi (4.8-6.2 bar)	70 - 90 psi (4.8-6.2 bar)

\*Actual results may be greater or less than those listed due to a number of factors including but not limited to warm up cycles, speeds, feeds, tooling, machine maintenance, coolant, material, ambient temperature and type of machine foundation.

T-42

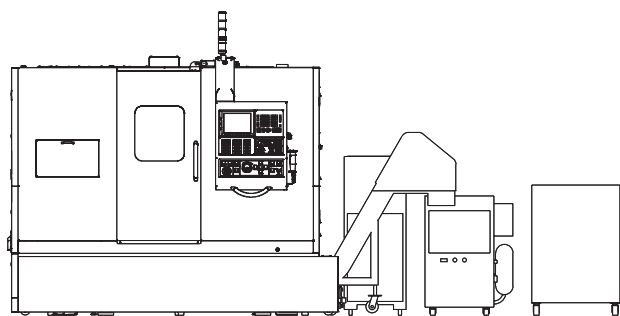

T-51 & T-65

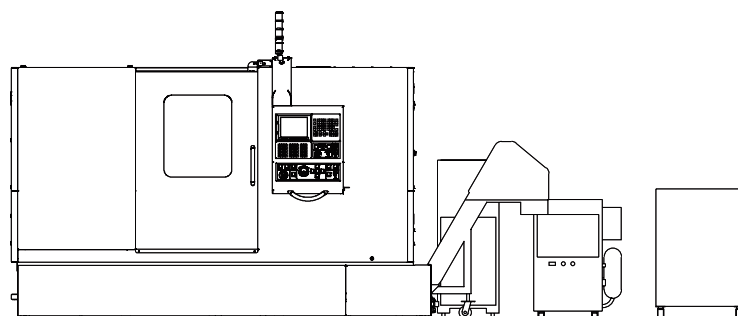

## HARDINGE COMPANIES WORLDWIDE

Over the years, The Hardinge Group™ steadily diversified both its product offerings and operations. Today, the company has grown into a globally diversified player with manufacturing operations in North America, Europe and Asia. In addition to designing and building turning centers, and collets, Hardinge is a world leader in grinding solutions with the addition of the Kellenberger, Jones & Shipman, Hauser, Tschudin, Usach and Voumard brands to the Hardinge family. The company also designs and manufactures Bridgeport machining centers and other industrial products for a wide range of material cutting, turnkey automation and workholding needs.

Expect more from your Hardinge products. Choose Hardinge precision and reliability for increased productivity and value!

Call us today, we've got your answer.



### North America

Hardinge Inc.  
General Information: 607-734-2281  
Sales Fax: 607.734.8819  
Workholding Fax: 607.734.3886  
Service: 800.424.2440  
[www.hardinge.com](http://www.hardinge.com)

### Canada

Canadian Hardinge Machine Tools Ltd.  
Tel: 800.468.5946  
Fax: 607.734.8819

### China

Hardinge Machine (Shanghai) Co. Ltd.  
Hardinge China Limited  
Tel: 0086 21 38108686  
Fax: 0086 21 38108681

Hardinge Precision Machinery (Jiaxing) Co., Ltd.  
Economic and Technology Development Zone  
Tel: 0573-82601088  
Fax: 0573-82601988

### Germany

Hardinge GmbH  
Tel: (49) 2151 496490  
Fax: (49) 2151 4964999

### Taiwan

Hardinge Machine Tools B.V.  
Tel: 886 49 2260536  
Fax: 886 49 2252203  
[cs@hardinge.com.tw](mailto:cs@hardinge.com.tw)

### Switzerland

L. Kellenberger & Co. AG  
Tel: +41 (0) 71 242 91 11  
Fax: +41 (0) 71 242 92 22  
[info@kellenberger.com](mailto:info@kellenberger.com)  
[www.kellenberger.com](http://www.kellenberger.com)

L. Kellenberger & Co. AG  
Tel: +41 (0)32 344 11 52  
Fax: +41 (0)32 341 13 93  
[info@kellenberger.com](mailto:info@kellenberger.com)  
[www.kellenberger.com](http://www.kellenberger.com)

### United Kingdom

Jones & Shipman Hardinge Limited  
Tel: +44 (0) 116 2013000  
Fax: +44 (0) 116 2013002  
[info@jonesshipman.com](mailto:info@jonesshipman.com)  
[www.jonesshipman.com](http://www.jonesshipman.com)

