

## GENERAL OSHA AND MANUFACTURER REQUIREMENTS FOR ALL SLINGS

### **▲ WARNING**

Read Definition on page 3

### Safe Operating Practices

1. **Sling users must be trained** in operating practices, including sling selection, use, inspection, rigging practices, cautions to personnel, and effects of environment.
2. **Inspect sling at least daily** and remove from service if damaged.
3. **Protect sling from being cut or damaged** by corners, protrusions, or from contact with edges that are not well rounded.
4. **Use sling properly.** Do not exceed a sling's rated capacities and always consider how the sling angle affects the amount of tension on the sling.
5. **Stand clear of load.** Do not stand on, under or near a load, and be alert to dangers from falling and moving loads, and the potential for snagging.
6. **Maintain and store sling properly.** Sling should be protected from mechanical, chemical and environmental damage.

### 1. Training

#### Sling Users must be Trained and Knowledgeable

Sling users must be knowledgeable about the safe and proper use of slings and be aware of their responsibilities as outlined in all applicable standards and regulations.

ASME B30.9 states: "*Sling users shall be trained in the selection, inspection, cautions to personnel, effects of the environment and rigging practices.*"

OSHA Sling Regulation 29 CFR 1910.184 states that a *qualified person* is one: "*who, by possession of a recognized degree or certificate of professional standing in an applicable field, or who, by extensive knowledge, training, and experience, has successfully demonstrated the ability to solve or resolve problems relating to the subject matter and work.*"

If you are unsure whether you are properly trained and knowledgeable, or if you are unsure of what the standards and regulations require of you, ask your employer for information and/or training – **DO NOT** use web slings if you are unsure of what you are doing. Lack of skill, knowledge or care can result in severe **INJURY** or **DEATH** to you and others.

### 2. Inspections

*Inspections. Each day before being used, the sling and all fastenings and attachments shall be inspected for damage or defects by a competent person designated by the employer. Additional inspections shall be performed during sling use, where service conditions warrant. Damaged or defective slings shall be immediately removed from service.*  
(OSHA Wording)

### Inspection Frequency

**Initial Inspection** - Each new sling must be inspected by a designated person to help ensure that the correct sling has been received, is undamaged, and meets applicable requirements for its intended use.

**Frequent Inspection** - The sling must be inspected by a designated person before each day or shift in **Normal** service conditions, or before each use in applications where a rapid rate of sling wear or other degradation may exist. (**Severe** service conditions).

**Periodic Inspection** - Every sling must be inspected "periodically". The designated person should be someone other than the person performing the frequent inspection.

The frequency of periodic inspections should be based on the sling's actual or expected use, severity of service, and experience gained during the inspection of other slings used in similar circumstances, but must not exceed a one year interval. General guidelines for the frequency of periodic inspections are:

- Normal service—yearly
- Severe service—monthly to quarterly
- Special service—as recommended

A written record of the most recent periodic inspection must be maintained. (See WSTDA WS-1 for definitions of service conditions.)

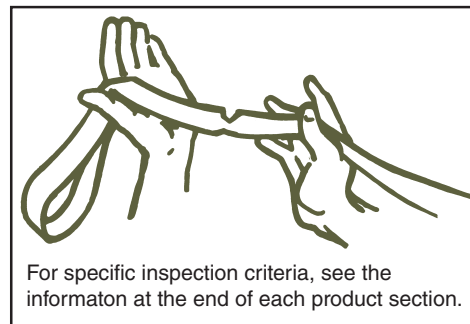

The Safety Bulletin that accompanies each sling must be read and understood by all sling users. See sling abuse illustrations in their respective section of this catalog. Damaged slings should never be used, but in some instances, it is possible to repair slings, proof test and return them to service. Damaged components and sections of chain or wire mesh can be replaced. Hooks, links and other components that are in good condition can be salvaged from a damaged web or round sling, rewedded, proof tested by *Lift-All* and returned to service.

## GENERAL OSHA AND MANUFACTURER REQUIREMENTS FOR ALL SLINGS

### 3. Protect Slings

#### **WARNING**

Read Definition on page 3

*Slings shall be padded or protected from the sharp edges of their loads.*  
 (OSHA Wording)

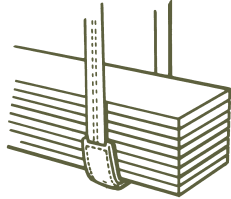

The cutting of synthetic slings is the main cause of sling failure; usually caused by a sharp or small diameter load edge against the sling. Proper protection must be used to avoid cutting. (See Sling Protection Section page 14).

Punctures & Abrasions seriously degrade sling strength. Rough load surfaces and dragging slings on the ground will damage all slings, steel or synthetic. Use proper padding between slings and rough loads. Never drag slings on ground or concrete floors.

#### Sling Protection

A qualified person must select materials and methods that adequately protect slings from edges or surfaces. Sleeves, wear pads, corner protectors, or other softeners are examples of materials commonly used as protection devices. However, **No protective device is "cut proof"**.

Some protection devices provide abrasion resistance, but offer virtually no protection against cuts. Several "test" lifts, done in a non-consequence setting, may be necessary to determine the suitability of each protection device. After each "test" lift, inspect **all** slings and protection devices for damage.

Foreign Matter - Material such as metal chips and heavy grit can damage slings, both internally and externally. Avoid contact with foreign matter whenever possible.

### 4. Use Slings Properly



- Slings shall not be dragged on floor.

*Improper Loading - Shock Loading, unbalanced loading, overloading and inadequate consideration for the effect of angle factors can adversely affect safety. Make sure the load weight is within the rated capacity of the sling(s) being used for both type of hitch and angle of lift.*  
 (OSHA Wording)

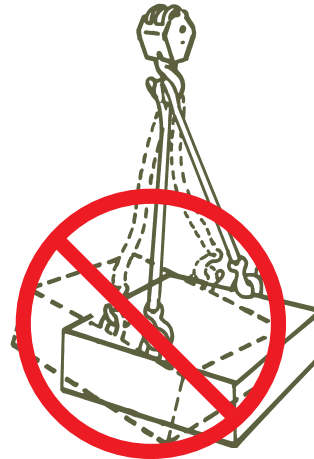

- Do not shock load. Jerking the load could overload the sling and cause it to fail.

- Lift must be stable with respect to the center of gravity - balanced.

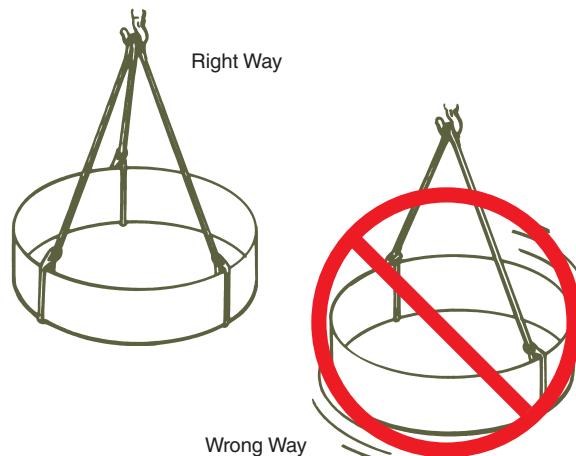

**GENERAL OSHA AND MANUFACTURER REQUIREMENTS FOR ALL SLINGS**

**⚠ WARNING**

Read Definition on page 3

*Slings used in a basket hitch shall have the loads balanced to prevent slippage.*  
(OSHA Wording)

- Angle of lift must be considered in all lifts. See page 12.

Temperature - Avoid loads and environments where temperatures exceed the limits of the slings being used. All slings can be damaged by excessive heat, including heat from welding torches and weld spatter.

Chemical Environment - Slings exposed to certain chemicals or the vapors of these chemicals can lose some or all of their strength. When using slings in a chemical environment, contact *Lift-All* to assure sling compatibility.

*Slings shall not be loaded in excess of their rated capacities.*  
(OSHA Wording)

- Rated capacities (Working Load Limits) must be shown by markings or tags attached to all slings.

- Temperature and chemical environment must be considered (see specific sling types for data).

Right Way      Wrong Way

- Do not point load hooks - center load in base of hook.

*Slings shall be securely attached to their loads.*  
(OSHA Wording)

## GENERAL OSHA AND MANUFACTURER REQUIREMENTS FOR ALL

### ▲ WARNING

Read Definition on page 3

*Slings shall not be shortened with knots or bolts or other makeshift devices.*  
 (OSHA Wording)



*Sling legs shall not be kinked.*  
 (OSHA Wording)



*A sling shall not be pulled from under a load when the load is resting on the sling.*  
 (OSHA Wording)

Right Way



Wrong Way

- Before a load is lifted, a place should be prepared where it is to be put down. Lumber can be used to allow space to remove the sling and prevent shifting of the load.

### 5. Stand Clear of the Load

*Hands or fingers shall not be placed between the sling and its load while the sling is being tightened around the load.*  
 (OSHA Wording)

Wrong Way

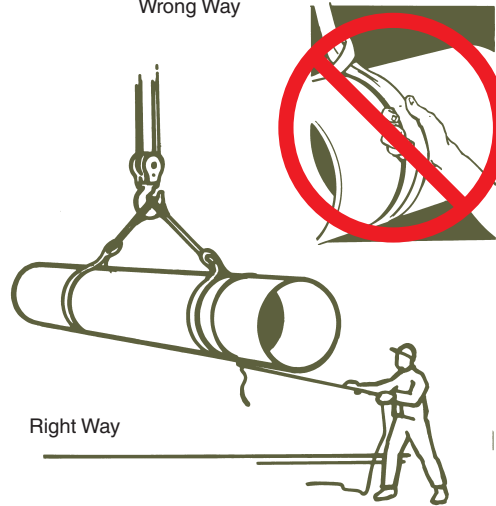

Right Way

- After lifting, the load should not be pushed or guided by employees hands directly on the load. Ropes or "tag lines" should be attached for this purpose.

*Suspended loads shall be kept clear of all obstructions.*  
*All employees shall be kept clear of loads about to be lifted and of suspended loads.*  
 (OSHA Wording)

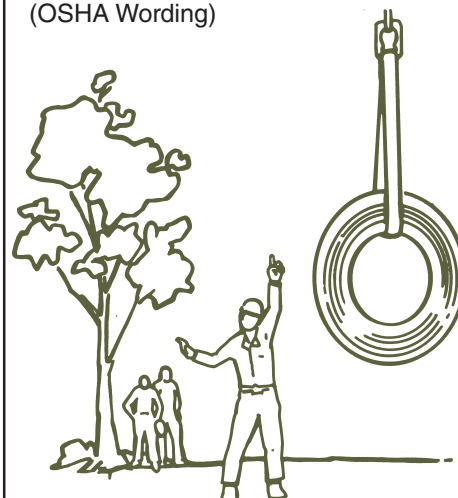

## GENERAL OSHA AND MANUFACTURER REQUIREMENTS FOR ALL

**⚠ WARNING**

Read Definition on page 3

### 6. Maintain and Store Sling Properly

Attempt to keep slings clean and free of dirt, grime and foreign materials.

When not in use, slings should be stored in an area free from environmental or mechanical sources of damage, such as: weld spatter, splinters from grinding or machining, or sources of UV, heat, or chemical exposure, etc.

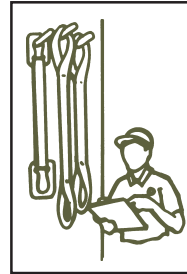

- Slings shall be stored in cool, dark, dry areas, preferably on racks.

Additional Factors to consider when handling loads

- Integrity of the attachment points
- Structural stability of the load
- Loose parts that could fall from load
- Power lines in the area
- Secure a clear load path and avoid any contact with objects that would impede load movement
- Tag lines can often be attached to the load and be used to aid in controlling load position

### Choker Hitch Angles

When a choke hitch is used, and the angle of choke is less than 120 degrees, the sling choker hitch capacity decreases. To determine the actual sling capacity at a given angle of choke, multiply the sling capacity rating (for a choker hitch) by the appropriate reduction factor determined from the tables below.

Adjusted choker hitch capacity = Choker Hitch Capacity x Reduction Factor

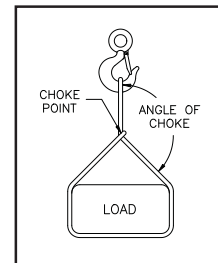

Reduction in rated capacity as a function of angle of choke

Synthetic Slings		
Angle of Choke		Factor
> or =	<	
120	180	1.00
105	120	.82
90	105	.71
60	90	.58
0	60	.50

Wire Rope Slings		
Angle of Choke		Factor
> or =	<	
120	180	1.00
90	120	.87
60	90	.74
30	60	.62
0	30	.49

Sling capacity decreases as choke angle decreases.

*Lift-All* is dedicated to manufacturing and developing products for material handling that meet or exceed current industry and government requirements (OSHA and ASME B30.9). Ultimately, the life and strength of any sling depends on those who inspect, use and maintain it.

The ASME B30.9 Sling Safety Standard can be obtained from:  
 ASME Customer Service  
 Phone: 800-843-2763  
[www.asme.org](http://www.asme.org)

Occupational Safety and Health Administration (OSHA) "Industrial Slings" Regulations are published by the Office of the Federal Register, National Archives and Records Administration - Part 29 1910.184  
[www.osha.gov](http://www.osha.gov)

## Effect of Angle of Lift on a Sling's Rated Capacity

### ⚠ WARNING

Read Definition on page 3

Using slings at an angle **can become deadly** if that angle is not taken into consideration when selecting the sling to be used. The tension on each leg of the sling is increased as the angle of lift, from horizontal, decreases. It is most desirable for a sling to have a larger angle of lift, approaching 90°. Lifts with angles of less than 30° from horizontal are not recommended. If you can measure the angle of lift or the length and height of the sling as rigged, you can determine the properly rated sling for your lift.

### INCREASED TENSION

#### What capacity sling do I need?

- Determine the weight that the sling will be lifting [LW].
- Calculate the Tension Factor [TF].
  - Using the angle from horizontal, read across the angle chart to the corresponding number of Tension Factor column.
  - OR -
  - Divide sling length\* [L] by sling height\* [H].
- Lifting Weight [LW] x the Tension Factor [TF] = Minimum Sling Rating for the type of hitch that will be used.

\* Measured from a common horizontal plane to the hoisting hook.

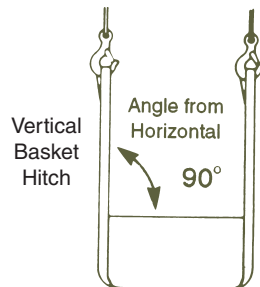
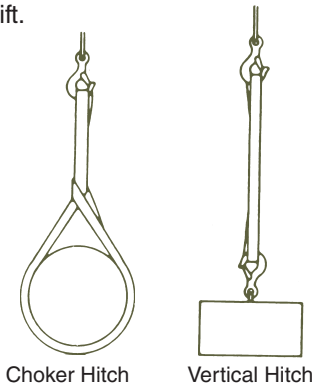

### REDUCED CAPACITY

#### What would be the rating of each sling rigged at this angle?

- Calculate the Reduction Factor [RF].
  - Using the angle from horizontal, read across the Angle Chart to the corresponding number of the Reduction Factor column.
  - OR -
  - Divide sling height\* [H] by sling length\* [L].
- Reduction Factor [RF] x the sling's rated capacity for the type hitch that will be used = Sling's Reduced Rating.

\* Measured from a common horizontal plane to the hoisting hook.

### Effect of Angle Chart

Tension Factor (TF)	Angle From Horizontal	Reduction Factor (RF)
1.000	90°	1.000
1.004	85°	0.996
1.015	80°	0.985
1.035	75°	0.966
1.064	70°	0.940
1.104	65°	0.906
1.155	60°	0.866
1.221	55°	0.819
1.305	50°	0.766
1.414	45°	0.707
1.555	40°	0.643
1.742	35°	0.574
2.000	30°	0.500

Sling capacity decreases as the angle from horizontal decreases. Sling angles of less than 30° are not recommended.

### Increased Tension

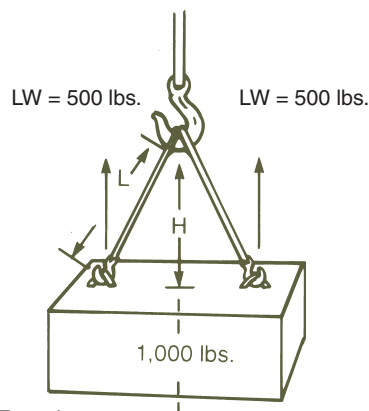

Example:  
 Load weight = 1,000 lbs.  
 Rigging - 2 slings in vertical hitch  
 Lifting Weight (LW) per sling = 500 lbs.  
 Measured Length (L) = 10 ft.  
 Measured Height (H) = 5 ft.  
 Tension Factor (TF) = 10 (L) ÷ 5 (H) = 2.0  
 Minimum Vertical Rated Capacity required for this lift = 500 (LW) x 2.0 (TF) = 1000 lbs. per sling

### Reduced Capacity

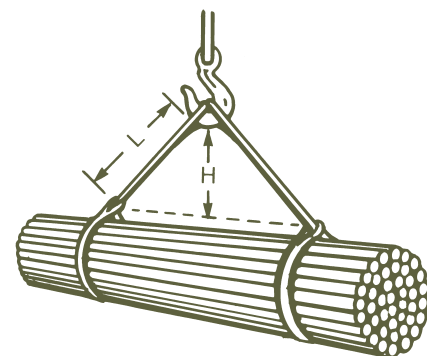

Example:  
 Vertical Choker rating of each sling = 6,000 lbs.  
 Measured Length (L) = 6 ft.  
 Measured Height (H) = 4 ft.  
 Reduction Factor (RF) = 4 (H) ÷ 6 (L) = .667  
 Reduced sling rating in this configuration = .667 (RF) x 6,000 lbs. = 4,000 lbs. of lifting capacity per sling