

HF TRANSCEIVER

# TS-850S

## SERVICE MANUAL

# TS-850S

## KENWOOD

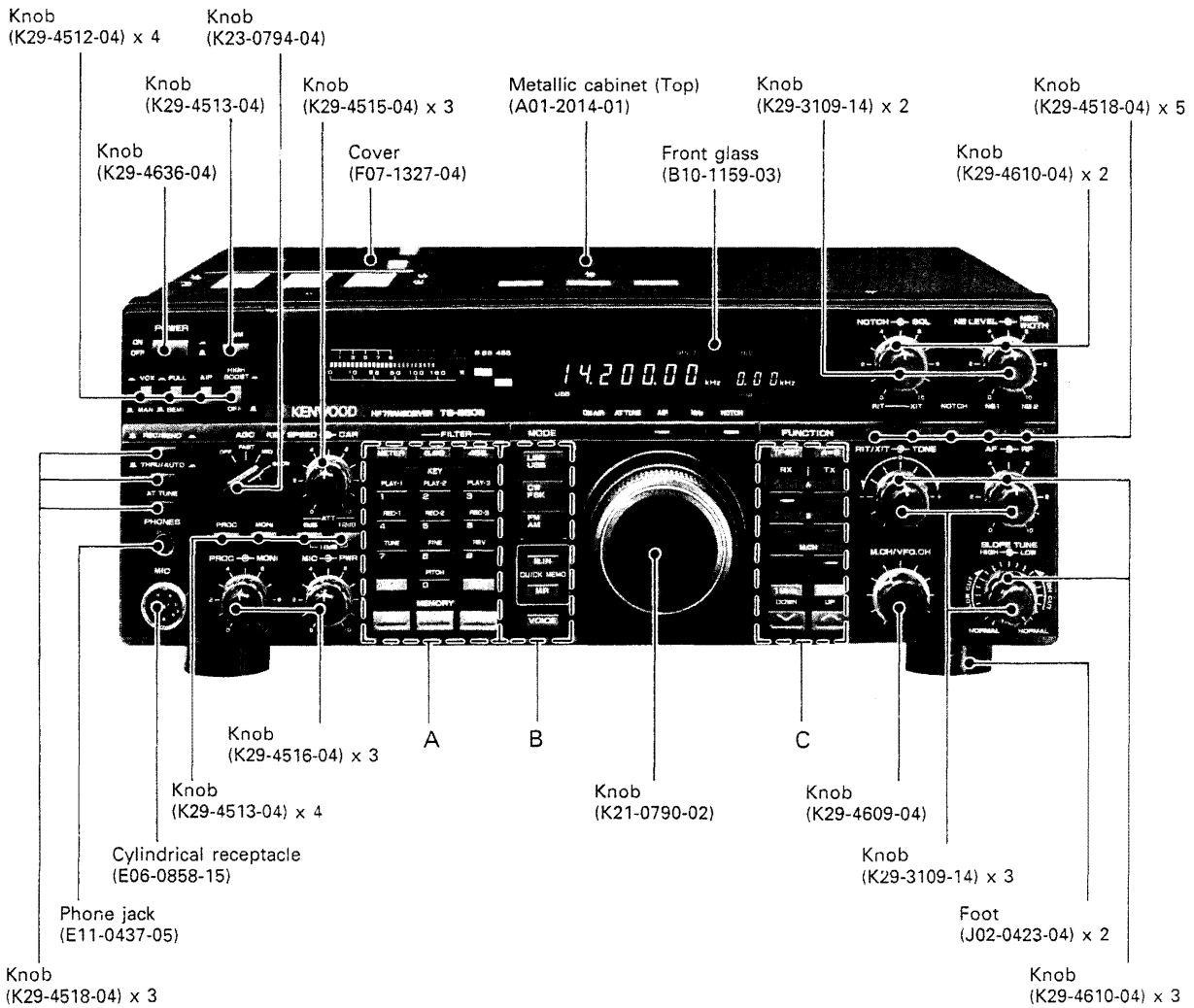

A		
Knob (K29-4623-03)	Knob (K29-4624-03)	Knob (K29-4625-03)
Knob (K29-4611-03)	Knob (K29-4612-03)	Knob (K29-4613-03)
Knob (K29-4614-03)	Knob (K29-4615-03)	Knob (K29-4616-03)
Knob (K29-4617-03)	Knob (K29-4618-03)	Knob (K29-4619-03)
Knob (K29-4621-03)	Knob (K29-4620-03)	Knob (K29-4622-03)
Knob (K29-4505-04)	Knob (K29-4506-04)	Knob (K29-4507-04)

B
Knob (K29-4633-03)
Knob (K29-4634-03)
Knob (K29-4635-03)
Knob (K29-4627-03)
Knob (K29-4628-03)
Knob (K29-4626-03)

C	
Knob (K29-4631-03)	Knob (K29-4632-03)
Knob (K29-3200-03)	Knob (K29-3200-03)
Knob (K29-3200-03)	Knob (K29-3200-03)
Knob (K29-3200-03)	Knob (K29-3200-03)
Knob (K29-4629-03)	Knob (K29-4630-03)
Knob (K29-4508-04)	Knob (K29-4509-04)

# TS-850S

## CONTENTS

<b>CIRCUIT DESCRIPTION</b>	
Frequency Configuration .....	3
Local Oscillator Circuit .....	5
CAR Unit .....	6
Receiver Circuit Description .....	9
Transmitter Circuit.....	13
Filter Unit .....	16
AT Unit .....	17
Standby Control Timing .....	19
Digital Control Unit.....	24
<b>DESCRIPTION OF COMPONENTS</b> .....	36
<b>SEMICONDUCTOR DATA</b> .....	45
<b>PARTS LIST</b> .....	53
<b>EXPLODED VIEW</b> .....	91
<b>PACKING</b> .....	95
<b>ADJUSTMENT</b> .....	96
<b>TERMINAL FUNCTION</b> .....	109
<b>CIRCUIT DIAGRAMS/PC BOARD VIEWS</b>	
DC-DC (X59-1100-00) .....	116
FM MIC (X59-3000-03) .....	116
AIP SW (X59-3900-00) .....	116
NB2 (X59-3910-00) .....	116
RF UNIT (X44-3120-00) .....	117
FINAL UNIT (X45-1470-02) .....	127
DIGITAL UNIT (X46-308X-XX) .....	129
IF UNIT (X48-3080-00) .....	141
VOX (X59-1080-00) .....	145
TRX (X59-3680-01) .....	145
AGC (X59-3820-00) .....	145
SM AMP (X59-3830-00) .....	145
MIC SW (X59-3840-00) .....	145
MIC AMP (X59-3850-00) .....	145
DELAY (X59-3860-00) .....	146
BK IN (X59-3870-00) .....	146
BK SW (X59-3880-00) .....	146
PLL UNIT (X50-3130-00) .....	155
VCO2 (X58-3390-03) .....	157
CAR UNIT (X50-3140-00) .....	161
FILTER UNIT (X51-3100-00) .....	165
AT UNIT/AT-850 (X53-3340-00) .....	169
LCD ASSY (B38-0350-15) .....	173
SWITCH UNIT A (X41-3130-00) .....	175
SWITCH UNIT B (X41-3140-00) .....	177
SCHEMATIC DIAGRAM .....	179
BLOCK DIAGRAM .....	187
LEVEL DIAGRAM .....	189
DRU-2 (DIGITAL RECORDING UNIT) .....	191
PS-52 (DC POWER SUPPLY) .....	198
SP-31 (EXTERNAL SPEAKER) .....	205
VS-2 (VOICE SYNTHESIZER) .....	207
SO-2 (TCXO UNIT) .....	208
SPECIFICATIONS .....	209

## CIRCUIT DESCRIPTION

### Frequency Configuration

The TS-850 utilizes triple conversion in receive mode, double conversion in CW and FM transmit modes, and triple conversion in SSB, AM, and FSK transmit modes.

When the DSP-100 (digital signal processor) is installed, the 36.89-kHz IF (fourth IF) signal goes to the DSP unit during reception; during transmission, the

input signal from the microphone or key goes to the DSP unit, and a 455-kHz signal goes to the main unit according to the mode. The DSP only produces a 455-kHz carrier in FM mode, the VCOs operate in the same way as when there is no DSP.

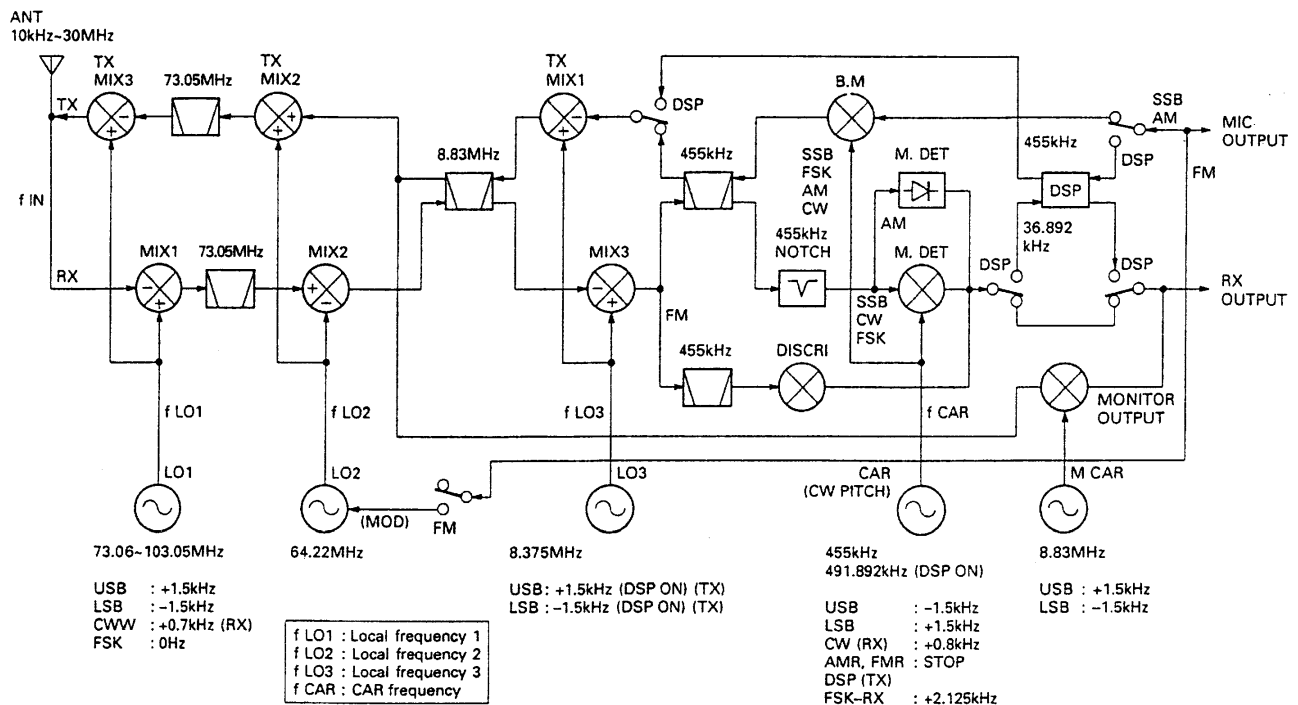

Fig. 1 Signal system frequency configuration

### 1) Frequency configuration

The receiver frequency in the SSB mode is given by the following equation when the receiver tone produced by the input frequency ( $f_{IN}$ ) from the antenna is zero beat (when an SSB signal with a carrier point of  $f_{IN}$  is zeroed in):

$$f_{IN} = f_{LO1} - f_{LO2} - f_{LO3} - f_{CAR} \dots \dots (1)$$

Since all these frequencies are generated by the DDS (Direct Digital Synthesis) system and the PLL (Phase Locked Loop) circuits (as shown in Fig. 2), the receiver frequency is determined only by the reference  $f_{STD}$ , the PLL divide ratio, and DDS data. Therefore, the stability/accuracy of the reference frequency determines the overall frequency stability/accuracy of the transceiver.

The stability/accuracy of the reference crystal oscillator used in the TS-850 is 10 ppm (-10 to +50°C). The stability/accuracy of the optional temperature-compensated crystal oscillator (TCXO, SO-2) is 0.5 ppm (-10 to +50°C).

The TS-850 local oscillator and the CAR DDS circuits are independent of each other. However, they can be operated in a way similar to a "cancel loop" configuration, by changing the CAR and local oscillator data simultaneously by means the microprocessor. This function allows changes in the  $f_{CAR}$  and  $f_{LO1}$  lines when the mode changes, and also allows the bandwidth of the slope tune circuits to be varied ( $f_{CAR}$  and  $f_{LO3}$ ,  $f_{LO3}$  and  $f_{LO1}$ ).





## CIRCUIT DESCRIPTION

### 2) LO2

Q1 (2SK508NV) of VCO2 (X58-3390-03) is used to generate a signal of 64.22MHz. The 10-MHz reference frequency ( $f_{REF}$ ) is applied to pin 5 of IC4 (CXD1225M) and is divided internally by 500 (2000 in FM mode), to produce a 20-kHz (5-kHz in FM mode) comparison frequency. The output from VCO2 is applied to pin 11 of IC4, and is divided internally by 3211 (12844 in FM mode). It is then compared with the 20-kHz (5-kHz in FM mode) reference signal by the phase comparator to lock the VCO2 frequency. Divide ratio data is supplied by the digital unit.

The output is amplified to about 5dBm by amplifier Q17 and passes through a low-pass filter. The impedance is converted and the signal is output.

### 3) LO1 PLL loop

Four VCOs, Q1 to Q4 (2SK210 x 4), generate 73.08- to 103.05-MHz signals. The reference signal of 10MHz is applied to pin 5 of IC3 (CXD1225M) and is divided by 20 internally to produce a 500-kHz comparison frequency. The output signal passes through amplifier Q12 and a band-pass filter, and is divided into two signals. One signal passes through the buffer and low-pass filter of Q14 (2SC2996) and is output to the RF unit.

The other signal is applied to pin 5 of mixer IC6 (SN76514N). The DLO1 signal of 4.45 to 4.95MHz is input to pin 5 of mixer IC from the carrier unit, and a 60-MHz signal (3 times the 20-MHz reference signal) is input to pin 1. The signal of 55.05 to 55.55MHz signal from mixer IC1 is applied to pin 11 of mixer IC6, and becomes a signal of 18.03 to 48.0MHz. The signal is output from pin 13, passes through the high-pass and low-pass filters, amplifiers Q16 (2SC2714) and Q15 (2SC2712), and is applied to pin 11 of IC3 (CXD1225M).

This signal is divided by N1 internally, compared with a 500-kHz signal by the phase comparator, and the mixer output frequency is locked in 500-kHz steps. Divide ratio N1 is sent from the digital unit as data (76 to 136) that covers 30kHz to 30MHz in 500-kHz steps. One of the four VCOs is selected according to the VCO switching data from the digital unit.

DLO1 sweeps 4.45 to 4.95MHz in 10-Hz or 1-Hz steps. The LO1 output covers 73.08 to 103.05MHz in 10-Hz or 1-Hz steps, and is output to the RF unit.

### 4) PLL data

The TS-850 has two PLLs as shown below, to which the main microprocessor sends PLL data based on the frequency indicated for each of the PLLs..

- VFO PLL
- Local oscillator PLL for frequency conversion

The VCOs are selected depending upon conditions:

- Main encoder changes → VCO1
- Mode changes → VCO2

When each PLL IC outputs an unlock signal and one of the PLLs is unlocked, the display is changed to "....." (decimal points only) to indicate that a PLL is unlocked.

Unlocking of each PLL can be confirmed by the fact that the status is output to the A0 terminal of pin 8 of the PLL IC (CXD1225M) as UL data.

Loop	VCO No.	IC No.	Comparison freq/ Divide ratio	Variable divide ratio	Frequency (MHz)
LO1	VCO1	IC3	500k/20	36-96	73.08-103.0
LO2	VCO2	IC4	20k/500 5k/2000 (FM)	3211 12844 (FM)	64.22

### CAR Unit

The TS-850 CAR unit has four newly developed DDS ICs, and generates small PLL steps (DLO1) that cover 10kHz to 30MHz in 1-Hz steps, the third local oscillator (LO3), CAR (CAR, MCAR), sidetone (STON), and sub-carrier signals. Kenwood's original DDS IC frequency modulation function is provided for FSK and subtone modulation.

#### 1) Reference signal

The 20-MHz reference signal from the PLL unit is amplified by Q3, buffered by CMOS inverter IC9, and supplied to the DDS ICs (IC1 to IC4) and IC5. This signal is halved by IC1 to IC4 to produce a DDS reference signal. It is divided by 5 by IC5, and a 4-MHz signal is supplied to the mixer that converts the IC1 output to DLO1.

#### 2) DLO1 generation

Digital signals from 0.95 to 0.45MHz are generated by IC1, converted to analog signals by the digital-to-analog (D/A) converter consisting of CP1, CP2, and Q1, passed through a low-pass filter, and are then applied to mixer IC6. Here they are mixed with a 4-MHz signal from IC5. The resulting signal is filtered by a combination of high-pass and low-pass filters to produce a signal in the range of 4.95 to 4.45MHz. This signal is output from buffer Q2 to the PLL unit as DLO1.

## CIRCUIT DESCRIPTION

### 3) LO3 generation

IC2 generates a digital signal with a basic frequency of about 1.625MHz. The signal is converted to an analog signal by the D/A converter consisting of CP3, CP4, and Q4, and chopped by a circuit consisting of Q5, Q6, and Q7 to extract the first harmonic component of about 8.375MHz. Undesired components of this signal are removed by ceramic filters CF1 and CF2. The resulting signal is amplified by Q8 and Q9, and output as the LO3 signal. During FM transmission, digital data from IC3 is input to the modulator to perform sub-tone modulation.

### 4) CAR generation

A digital signal of about 455kHz is generated by IC4, converted to an analog signal by the D/A converter consisting of CP7, CP8, and Q17, buffered by Q18, passed through a low-pass filter, and output as the CAR signal.

In the FSK mode, FSK modulation is performed directly by IC4 using the RTK signal supplied via digital transistor Q19 for level conversion.

### 5) MCAR generation

When transmitting in the SSB and FSK modes, IC3 generates a digital signal with a basic frequency of about 1.17MHz. The signal is converted to an analog signal by the D/A converter consisting of CP3, CP4, and Q4, and chopped by a circuit consisting of Q11, Q12, and Q13 to extract the first harmonic component of about 8.83MHz. Undesired components are removed by ceramic filters CF3 and CF4, and the resulting signal is amplified by Q14 and Q15, and output as the MCAR signal.

### 6) STON generation

In the CW mode, a digital signal of the CW pitch is generated by IC3, converted to an analog signal, passed through buffer Q16 and CR filter, and output as the STON signal.

### 7) Subtone generation

When transmitting in the FM mode, IC3 generates a digital subtone frequency, and directly outputs it to IC2 without converting it to an analog signal.

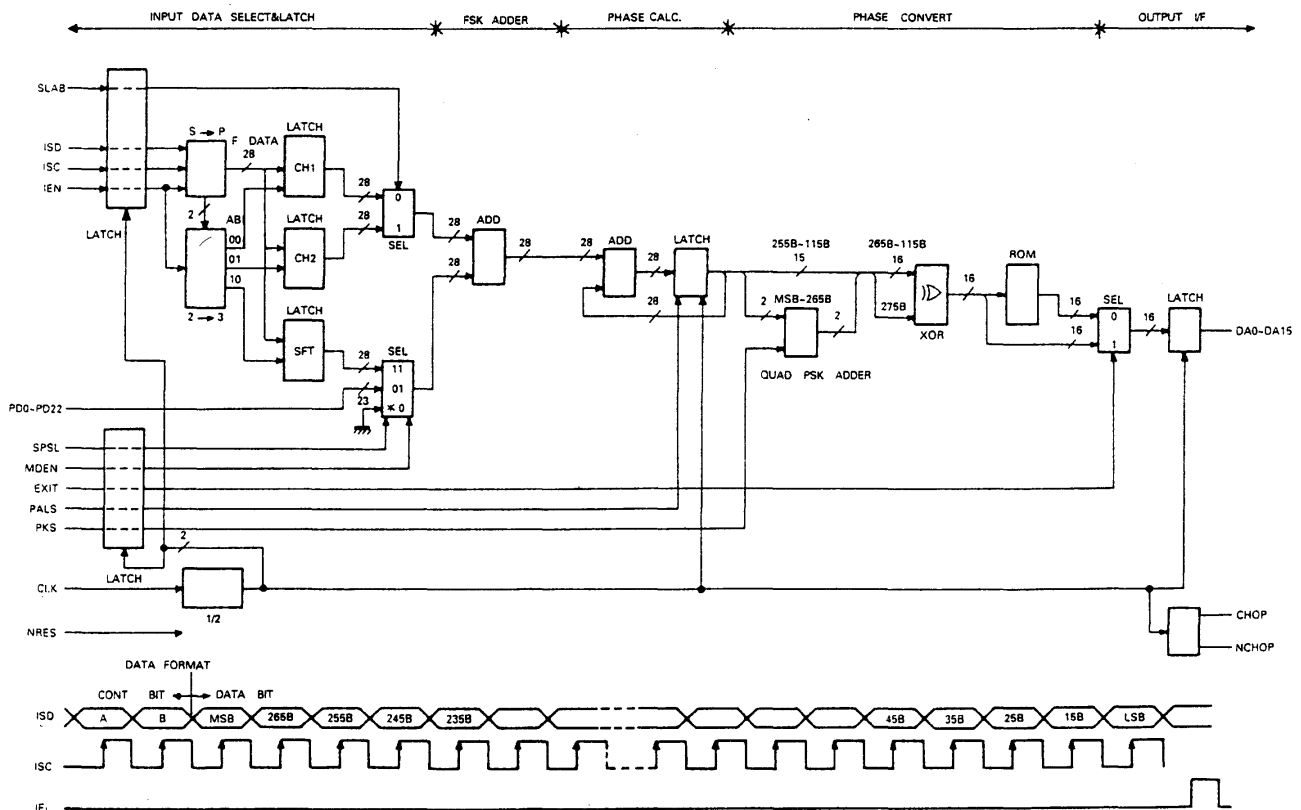

Fig. 4 DDS IC : YM6631 block diagram and data format

## CIRCUIT DESCRIPTION

### 8) DDS

The DDS IC has been developed with standard cells to implement a high-speed circuit and large-capacity ROM at a low cost.

#### • IC configuration

There are two 28-bit registers for programming frequency data, one 28-bit frequency shift register for addition to the frequency registers, a 23-bit parallel signal input section for frequency modulation with parallel signals, and a data entry and selection section.

There is a frequency-modulation section consisting of 28-bit adders for adding frequency data and frequency modulation data; a phase data operation section that adds data from the frequency modulation section and 28-bit phase data register; and a SIN-ROM that converts phase data to sine signals.

#### • Frequency/shift data setting

30 bits (2 bits that specify the destination for which data is set and 28 bits for frequency data) are set in the three internal registers using serial signals synchronized with the internal clock.

#### • Frequency register selection

The data set in the two frequency registers is selected by the SLAB input of the DDS IC. This pin handles the ABSL signal for IC1 and IC3, and the CASL signal for IC2 and IC4. This function eliminates the need for the TS-850 to set frequency data for each transmission/reception with the microprocessor.

#### • Frequency data selection

The SPSL input of the DDS IC selects whether to use the data in the internal frequency shift register or the data from the parallel input as frequency modulation data.

#### • Frequency modulation

The MDEN input of the DDS IC enables or disables frequency modulation. When frequency modulation is enabled, frequency data is added, and the result is input to the phase data operation section.

#### • Phase data operation

The desired frequency phase data is output by collecting 28-bit frequency data in the 28-bit phase accumulator.

$$F_{out} = F_s / 2^{28} \cdot D_{sum}$$

$F_s$  : DDS IC input frequency/2

$D_{sum}$ : Frequency data + Frequency modulation data

If  $2^{25}$  is set for  $D_{sum}$  when  $1/8 F_s$  is output, the phase data must be increased by  $1/8$ .

A 28-bit absolute value operation has been used so far, but a 28-bit signed operation can also be used, assuming that the MSB is a sign. If complementary data of 8000000 to FFFFFFFF (hex) is set, the phase moves in the negative direction for the positive data.

#### • SIN ROM

Phase data from the phase data operation section is converted to sine data of 0000 to FFFF (hex) in the 16-bit offset binary format.

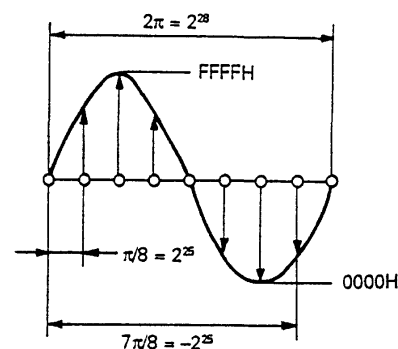

### 9) Chopper

When the output from the DDS IC is converted to an analog signal by the D/A converter with a ladder resistor network, the possible output frequency range is 0 to  $F_s/5$ . To obtain an output of 8.83/8.375MHz, 1.17/1.625MHz is produced and then converted to 8.83/8.375MHz by a mixer. When the DDS output spectrum is seen when  $F_s$  is 10MHz, the basic frequency of 1.17/1.625MHz and a harmonic component of 8.83/8.375MHz can be recognized. The level of this signal component is lower than the basic signal level because of the aperture effect, and the C/N ratio is less than ideal. The D/A output is extracted as a series of thin rectangular pulses by the chopper that are used to increase the level to that of the basic signal level, and thus obtain an output with a good C/N ratio. Use of the chopper eliminates the need for a filter in the mixer input.

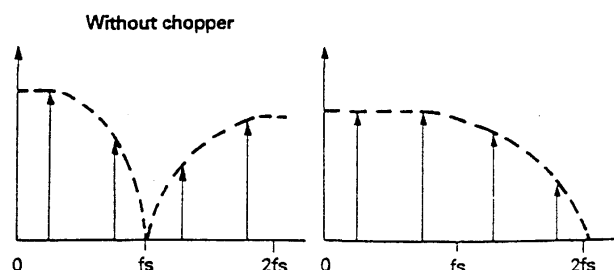



## CIRCUIT DESCRIPTION

### Receiver Circuit Description

The basic configuration of the receiver circuit is that of a triple-conversion superheterodyne. Fig. 5 shows the frequency configuration.

The incoming signal from the antenna is switched to the receiver by the antenna switching relay on filter unit (B/3). The signal passes through an image filter, and is applied to the CN1 (RAT) terminal of the RF unit via a coaxial cable. The signal is amplified by the first and second RF amplifiers and is then applied to the 1st RX mixer. Here the signal is converted into the 1st RF signal of 73.05MHz. The signal is then applied to a 73.05MHz MCF (Monolithic Crystal Filter) to remove unwanted components, that result from the mixing process, from the incoming signal. The 1st RF signal is then applied to the 2nd RX mixer in order to obtain the 2nd RF frequency of 8.83MHz. The resulting signal is then filtered to remove the unwanted components that result from the mixing action. Signals are transferred to and from the IF unit at 8.83MHz. The signal is converted to 455kHz by a third RX mixer in the IF unit, and processed to produce an audio signal.

The differences in operations between the TS-850 and some of Kenwood's previous models are listed below.

**RF ATT:** The 10-dB step has been changed to provide 6-dB steps.

**RF band-pass filter:** Two low-pass filters and 10 band-pass filters are used for 100kHz to 30MHz. For frequencies beyond the BC band, interference by high-output AM stations is minimized by passing the signals through a high-pass filter of  $f_c = 1.6\text{MHz}$ . The undesired signals in the 7-, 14-, and 21-MHz antenna bands are removed by a special adjustable narrow-band band-pass filter. The TS-850 also uses these band-pass filters in transmit mode to transmit radio signals with few spurious signals.

**RF amplifier:** If AIP is off, an RF amplifier is inserted before the first mixer. If the frequency is 22MHz or less, the NFB amplifier using J-FETs (Q2, Q3, 2SK125-5) for good large input characteristics is selected automatically. If the frequency is higher than 22MHz, the amplifier using a MOS-FET (Q1, 3SK131) for good sensitivity is selected automatically.

**RF gain:** The RF gain does not work in FM mode to prevent squelch malfunctions.

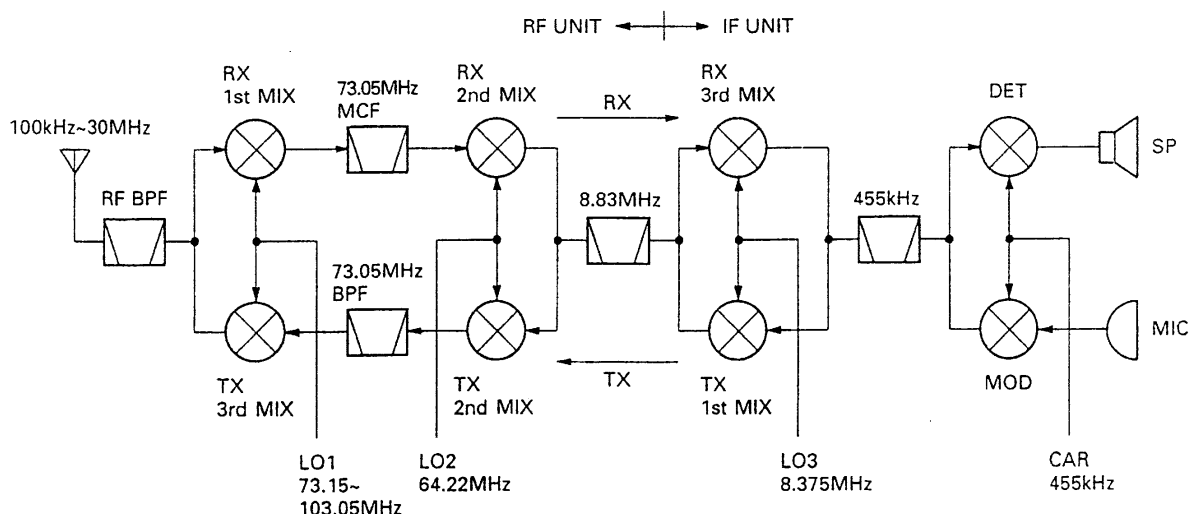

Fig. 5 Frequency configuration

## CIRCUIT DESCRIPTION

### 1) RF band-pass filter switching signal decoding

There are 12 bands to be switched, but only 10 outputs from IC1. The two extra bands are generated by a logic circuit consisting of IC2, Q48, Q6, and Q7.

IC1 input logic				Decoder output	
15 pin	14 pin	13 pin	12 pin	Pin that goes low when active	Band-pass filter
L	H	L	L	3	0.1~0.5MHz
H	L	L	L	2	0.5~1.62MHz 0.5~1.705MHz (K type)
L	L	H	L	5	1.62~2.5MHz
L	L	L	H	10	2.5~4MHz
L	H	L	H	Q6	4~7MHz
L	L	L	L	1	7~7.5MHz
H	H	H	L	9	7.5~10.5MHz
H	H	L	H	Q7	10.5~14MHz
H	H	L	L	4	14~14.5MHz
H	L	L	H	11	14.5~21MHz
L	H	H	L	7	21~22MHz
H	L	H	L	6	22~30MHz

### 2) RF amplifier switching and AIP switching

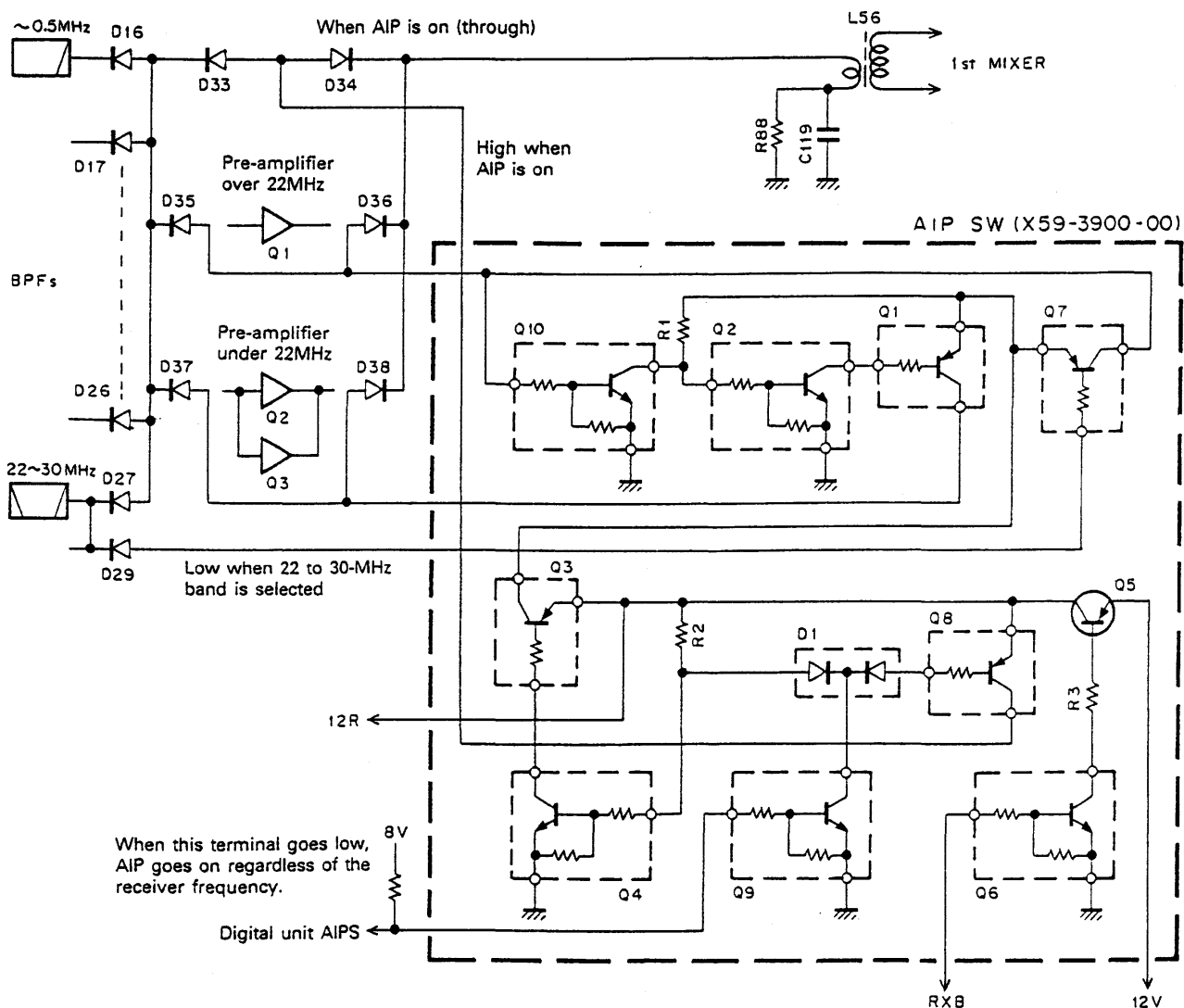

Fig. 6 RF amplifier switching and AIP switching

## CIRCUIT DESCRIPTION

### 3) Noise blanker

The circuit up to the detection stage is the same as previous versions of this circuit. When the NB1 switch is on, the noise pulse passes through Q605, Q607, and D604, and drives the NB gate. Since Q606 power is off, the pulse signal is not transmitted any farther, and NB2 does not operate. When the NB2 switch is on, the noise pulse passes through Q606, Q608, and D604.

Previous versions of NB2 had a problem that occurred when the blanking time increased, the signal was blanked and the desired signal was not obtained if there was a noise with a short period, such as ignition noise. This meant that the blanking time had to be about 5ms. Considering the fact that the period of woodpecker noise is generally 100 nsec, the TS-850 has a pulse period identification circuit that passes only pulses with a period of 100ms  $\pm$  about 30ms to minimize the possibility of malfunction due to noise even if the blanking time is increased.

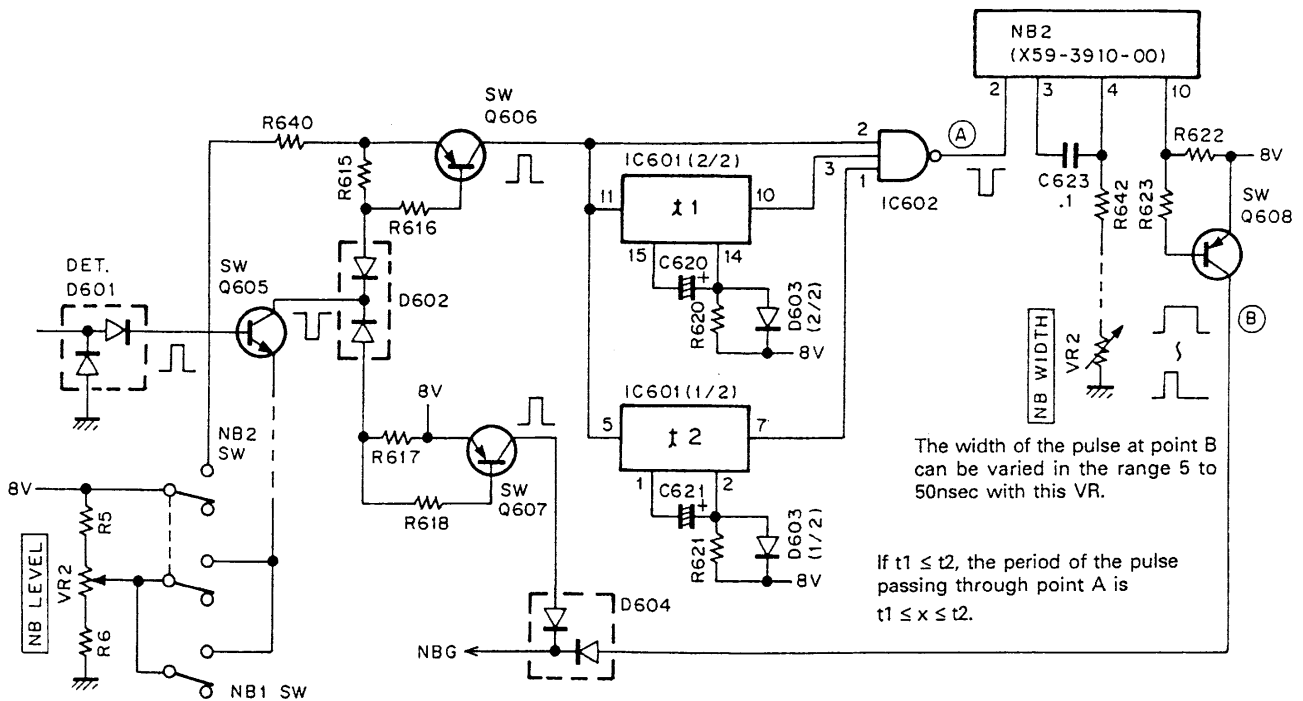

Fig. 7 Noise blanker circuit

## CIRCUIT DESCRIPTION

### 4) IF filter selection

Two optional 8.83-MHz filters and one 455-kHz filter can be installed.

#### Initial condition

Display	8.83MHz	Display	455kHz
No display	Through (LC filter)	12kHz	L72-0315-05
6kHz	L71-0266-05	6kHz	L72-0319-05
2.7kHz	L71-0222-05	2.7kHz	L72-0333-05
500Hz*	Option (not installed)	500Hz*	Option (not installed)
270Hz*	Option (not installed)		

Frequencies marked \* are not displayed by operating the filter changeover switch. They can be displayed by setting the corresponding bit of S501 in the RF unit (X44-3120-00 C/4) on when an optional filter is installed.

#### Optional filter types

8.83MHz		455kHz	
500Hz	YK-88C-1	500Hz	YG-455C-1
270Hz	YK-88CN-1		

Filters with bandwidths other than the ones described above can be installed. If this is done, the bandwidth displayed on the main display would not correspond with the actual bandwidth.

Item	Rating
Nominal center frequency	73.05MHz
Pass bandwidth	$\pm 7.5\text{kHz}$ or more at 3dB
Attenuation bandwidth	$\pm 30\text{kHz}$ or less at 40dB
Ripple	1.0dB or less
Insertion loss	3.0dB or less
Guaranteed attenuation	70dB or more at $f_0 + (500 \text{ to } 1000) \text{ kHz}$ 70dB or more at $f_0 - (200 \text{ to } 1000) \text{ kHz}$
Center frequency deviation	Within $\pm 1.5\text{kHz}$ at 3dB
Input and output impedance	$2\text{k}\Omega \pm 10\%$

#### MCF (L71-0401-05) (RF unit XF1)

Item	Rating
Nominal center frequency	8830kHz
Center frequency deviation	Within $\pm 150\text{Hz}$ at 6dB
Passband width	$\pm 1.3\text{kHz}$ or more at 6dB
Attenuation bandwidth	$\pm 1.7\text{kHz}$ or less at 20dB $\pm 2.5\text{kHz}$ or less at 60dB $\pm 3.4\text{kHz}$ or less at 80dB
Ripple	2dB or less
Insertion loss	6dB or less
Guaranteed attenuation	80dB or more in the range $\pm 3.4\text{kHz}$ to $\pm 1\text{MHz}$
Input and output impedance	$600\Omega / 15\text{pF}$

#### MCF (L71-0222-05) (RF unit XF2)

Item	Rating
Nominal center frequency ( $f_0$ )	8830kHz
Pass bandwidth	$f_0 \pm 3.0\text{kHz}$ or more at 6dB
Attenuation bandwidth	$f_0 \pm 16.0\text{kHz}$ or less at 60dB $f_0 \pm 13.0\text{kHz}$ or less at 50dB
Guaranteed attenuation	70dB or more within $f_0 \pm 1\text{MHz}$
Ripple	Within 1.0dB
Insertion loss	Within 1.5dB
Input and output impedance	$1850\Omega / 2\text{pF}$

#### MCF (L71-0266-05) (RF unit XF3)

Item	Rating
Nominal center frequency	$455 \pm 0.20\text{kHz}$
6dB bandwidth	2.9 to 3.2kHz
60dB bandwidth	4.7kHz or less
Guaranteed attenuation	60dB or more at 0.1 to 1MHz
Spurious	40dB or more at 600 to 700kHz
Ripple (in 6dB band)	2dB or less
Insertion loss	6dB or less
Guaranteed attenuation	60dB or more within $\pm 40\text{kHz}$
Input and output impedance	$2\text{k}\Omega$

#### Ceramic filter (L72-0333-05) (IF unit CF1)

Item	Rating
Nominal center frequency	455kHz
6dB bandwidth	$\pm 6\text{kHz}$ or more (at 455kHz)
50dB bandwidth	$\pm 12.5\text{kHz}$ or less (at 455kHz)
Ripple (within $455 \pm 4\text{kHz}$ )	3dB or less
Insertion loss	6dB or less
Guaranteed attenuation (within $455 \pm 100\text{kHz}$ )	35dB or more
Input and output impedance	$2.0\text{k}\Omega$

#### Ceramic filter (L72-0315-05) (IF unit CF2)

Item	Rating
Nominal center frequency	455kHz
6dB bandwidth	$\pm 3\text{kHz}$ or more (at 455kHz)
50dB bandwidth	$\pm 9\text{kHz}$ or less (at 455kHz)
Ripple (within $455 \pm 2\text{kHz}$ )	2dB or less
Insertion loss	6dB or less
Guaranteed attenuation (within $455 \pm 100\text{kHz}$ )	60dB or more
Input and output impedance	$2.0\text{k}\Omega$

#### Ceramic filter (L72-0319-05) (IF unit CF3)

## CIRCUIT DESCRIPTION

### Transmitter Circuit

The audio signal from the microphone enters CN22 of the IF unit. The signal is split and directed to input/output connector CN21 of the optional DRU-2 and the microphone amplifier module (X59-3850-00). The microphone amplifier module contains a microphone amplifier with a gain of about 20dB and a mixer for data entry. The audio signal is amplified by the microphone amplifier, passes through the mixer, and is output from the microphone amplifier module.

The signal output from the microphone amplifier module is split and directed to the microphone amplifier output for the optional DSP-100, the FM microphone amplifier, and the SSB, AM microphone gain potentiometer. SSB is mainly explained below. The FM system will be described later.

The signal that is controlled by the microphone gain potentiometer (processor potentiometer when a speech processor is used) on the front panel, enters CN of the IF unit. The microphone gain potentiometer or processor potentiometer output is switched by the microphone switch module (X59-3840-00). The signal from the microphone switch module is amplified by Q26 and modulated to 455-kHz DSB by the balanced modulator (IC3). The carrier (CAR) is generated by the DDS in the carrier unit (X50-3140-00) (about 0dBm), and enters CN9 of the IF unit. LO4 is split and directed to the buffer amplifier (Q25) for the receive and transmit carriers. LO4 from the buffer amplifier passes through the pin diode (D28) for carrier level adjustment, and enters the balanced modulator (IC3). This diode is completely on in SSB.

The DSB signal passes through ceramic filter CF1 (2.7-kHz band) and is converted into an SSB signal. The signal passes through the buffer amplifier (Q9), and is mixed with LO3 (8.375MHz) generated by the DDS in the carrier unit to produce 8.83MHz. The 8.83-MHz SSB signal enters CN19 of the RF unit from CN6 of the IF unit.

The signal entering the RF unit passes through ceramic filter CF1 (2.7-kHz band), amplifier (Q20) to which ALC is applied, and pin diode (Q89) that controls the gain when the power is controlled, and is converted to 73.05MHz by the second mixer (Q23, Q24). The signal passes through a three stage LC filter, and is converted to the desired frequency by the final mixer. The SSB signal converted to the desired frequency passes through the receive band-pass filter, is amplified by RF drive amplifier (Q5), and output to the final unit from CN2.

The signal is amplified to about 100W by the final unit. Harmonic components are attenuated by the filter unit, and the signal is output from the antenna connector.

In AM a DC bias is applied to the balanced modulator (IC3) of the IF unit in order to unbalance it and pass the signal. The carrier level is controlled by setting the current flowing to the pin diode for carrier level adjustment to an appropriate level with the CAR potentiometer on the front panel. For FM, the output from the microphone amplifier module enters CN603 of the RF unit (B/4) from CN23 of the IF unit, passes through the FM microphone amplifier module (X59-3000-03) of the pre-emphasis and IDC circuit, is output from CN603, enters CN8 of the PLL unit, and LO2 (64.22MHz) is modulated.

The carrier for CW, FM, and FSK is adjusted to an appropriate level by changing the current thru pin diode (D28) in the IF unit with the carrier potentiometer. The carrier passes through W1 on the bypass line of the 455-kHz ceramic filter, enters the first mixer, is converted to 8.83MHz, and enters the RF unit. The signal passes through the same route as for SSB and is transmitted from the antenna. CW keying is performed by the ALC voltage and the first and second gates of the second mixer.

CIRCUIT DESCRIPTION

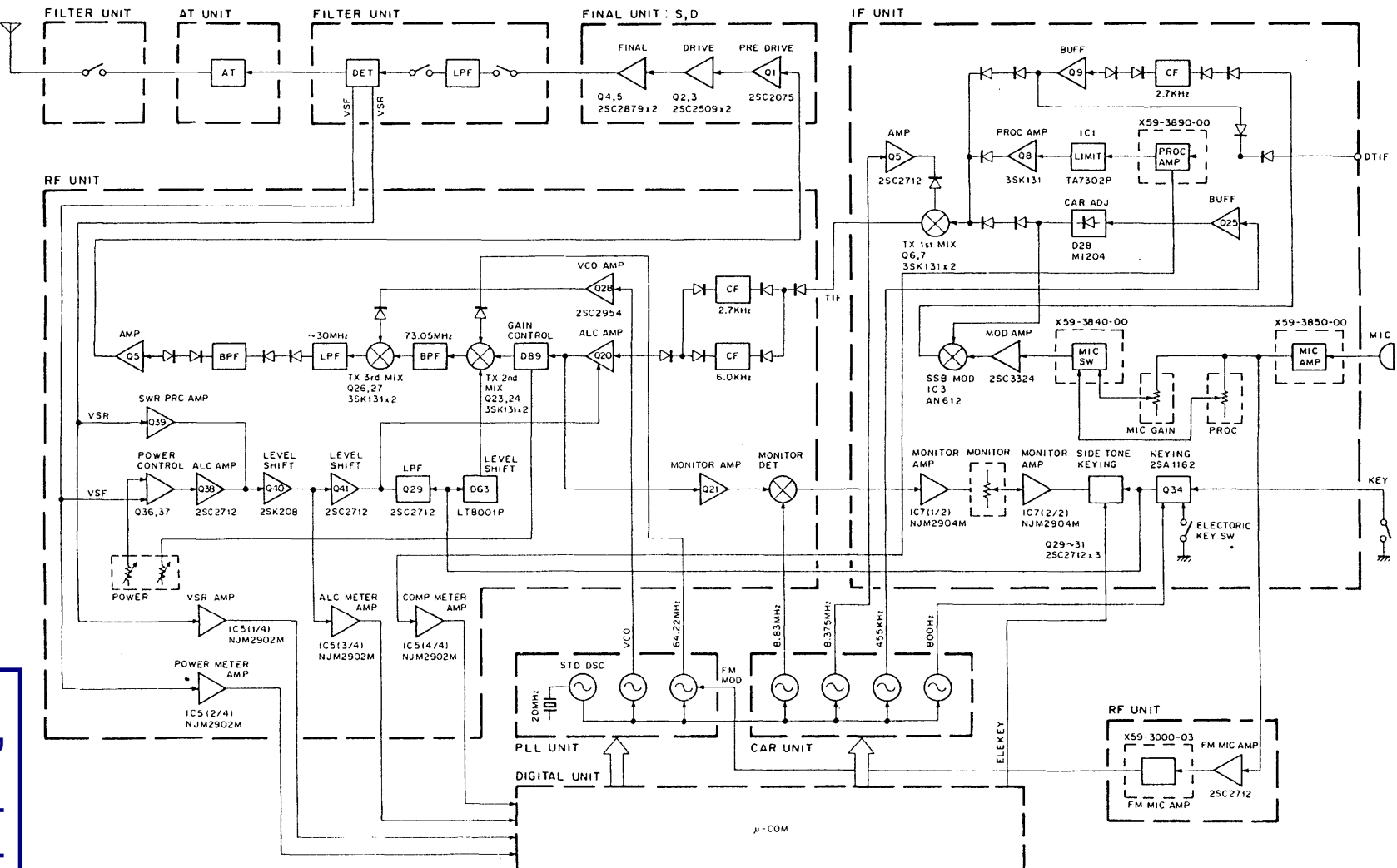

Fig. 8 Transmitter circuit block diagram

## CIRCUIT DESCRIPTION

### 1) Power control and power settings

The TS-850 power is controlled in almost the same way as the TS-950. The forward wave voltage detected by the filter unit enters the RF unit, is set to an appropriate level by resistor (VR7), and enters differential amplifier (Q36, Q37). The gain of this differential amplifier is changed by changing the base voltage of Q37. If the power is relatively low, such as in the S-type minimum power condition or AT-TUNE condition, the base voltage of Q37 is decreased, and the gain of the differential amplifier is increased. When the gain of the differential amplifier is increased, the apparent forward wave voltage increases, and the ALC circuit operates with less power, and the maximum power is reduced.

If the drive level is not decreased as the power is decreased, over-drive occurs. To prevent this, the gain of the amplifier of the signal system in the ALC loop is decreased. This changes the ALC level and changes the current through pin diode (D89) of the RF unit (by means of VR11 B/2 of the switch unit [F/6]) to set the drive level to an appropriate level. The difference between the TS-850 and TS-950 is that the TS-850 has a ceramic trimmer (TC1) connected to the pin diode in parallel to adjust and correct the minimum drive level.

In AT-TUNE, Q31 is turned on and Q34 is turned off by the ATPD signal from the microprocessor to disconnect VR11. Q52 is turned on to connect R297 to the base of Q37 to keep the power at 10 W regardless of the power control potentiometer position. Q30 is turned on and Q32 is turned off, and VR4 (TYP) for 50-W adjustment is also disconnected. The resistance of R297 determines the power for AT-TUNE.

The TUNE mode is similar: when the TPD signal goes low, Q46, Q30, Q31, and Q35 are turned on, the power control potentiometer (VR11 A/2) and 50-W setting potentiometer (VR4, TYP) are disconnected, and potentiometer (VR6, TUNE) for the TUNE mode is connected to the base of Q37.

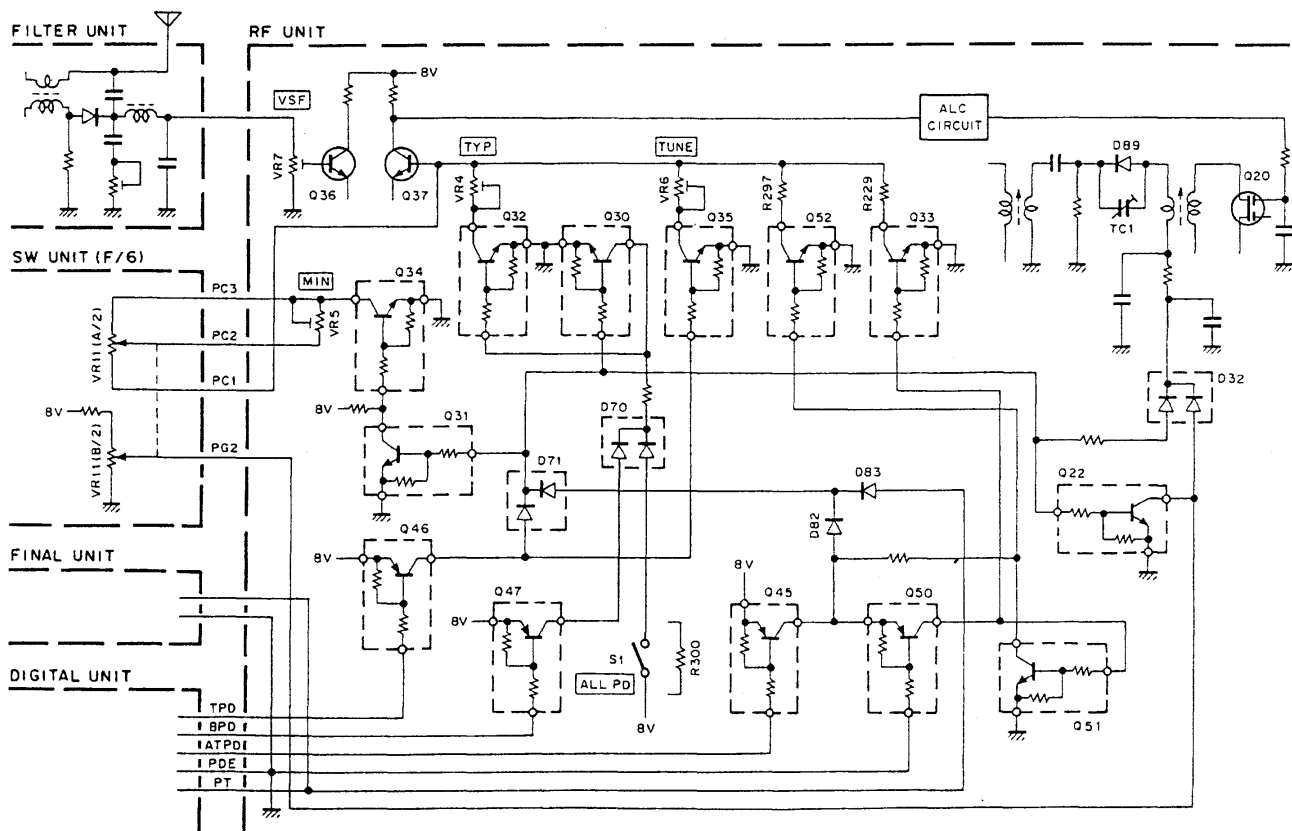

Fig. 9 Power control and power setting





## CIRCUIT DESCRIPTION

### AT Unit

#### 1) Auto antenna tuner

When the AUTO/THRU switch is set to AUTO, the signal is converted by the digital unit, ATA goes low, the AUTO/THRU switching relay K1 closes, and the AT is inserted to prepare for tuning. If variable capacitors VC1 and VC2 are not at their preset positions, they are set to the preset positions. AT TUNE operation and transmission do not start until the preset has been completed.

When AT TUNE is turned on, ATS goes high, the mode is switched to CW, and the transmitter output becomes about 10W. If the VSWR is less than 1.2, tuning is regarded as completed, and the AT TUNE operation stops.

If the VSWR is greater than 1.2, the duty cycle of the motor control pulse (described later) is varied according to the VSWR.

The motor speed is determined by the microprocessor, and the direction is determined by the phase comparator (IC1) and amplitude comparator (IC6) if the APRE is low, and by the microprocessor if the APRE is high.

#### • Auto tuning mode

The transmitter power from the final unit passes, via the filter unit, through current/voltage detection transformers L1 and L2, which have toroidal cores. The current and voltage components detected here are rectified by a waveform rectification circuit consisting of D4, Q1, D7, and Q2, and are then phase-compared by IC1 (SN74S74N). The output signals ( $\bar{Q}$  and Q) from

pins 8 and 9 of IC1 are passed through the switch by IC2 (TC4066BP), and are applied to the motor drive IC (IC4). Variable capacitor VC1 is turned by motor M1 so that the phase difference of the voltage and current components decreases.

The voltage and current components detected by L1 and L2 are rectified by germanium diodes (1N60) D1 and D2, and are applied to voltage comparison circuit IC6 (NJM2903S) as the amplitude component of the signal. The comparator output is passed through the switch by IC3 (TC4066BP). Motor M2 is driven by another motor drive IC, IC5 (BA6109U2), which turns variable capacitor VC2 in the direction that decreases the amplitude difference of the voltage and current components.

Therefore, variable capacitor VC1 adjusts the capacitance of the circuit so that the current and voltage phases match, and variable capacitor VC2 adjusts the resistance of the circuit so that the current and voltage amplitude difference decreases. If the phases match and the amplitude difference is zero, the SWR is 1 : 1.

The speed of motors M1 and M2 is determined by the duty cycle of the pulse input to control input pin 8 of IC4 and IC5. It is controlled according to the VSWR calculated by the CPU in the digital unit and the speed corresponding to preset or manual tuning.

Pulse signal SPED output from the digital unit passes through Q5 (DTC114EK), and is amplified by Q4 (2SA1204) to produce a control pulse input to IC4 and IC5.

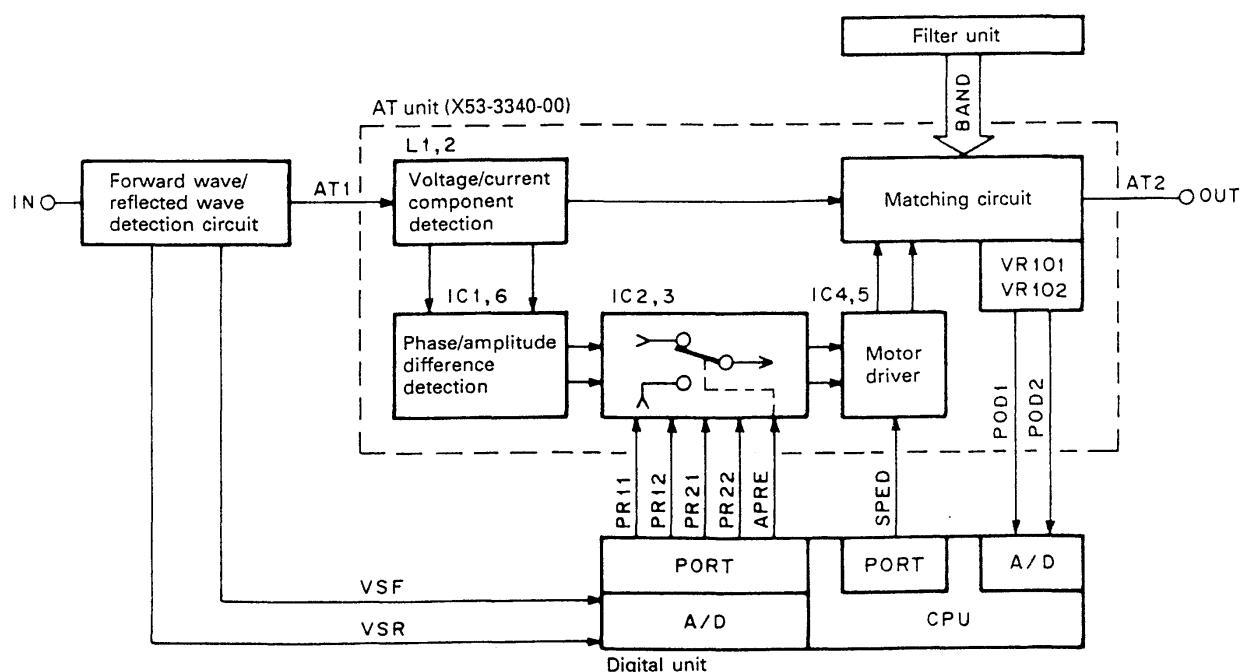

Fig. 12 Block diagram of auto antenna tuner

## CIRCUIT DESCRIPTION

When the SWR is 3 : 1 or more, the motor runs at high speed since the duty cycle of the motor drive voltage pulse is 100%. When the SWR is 2 : 1, the duty cycle becomes about 50%, and the motor runs at low speed.

The matching circuit used in the tuner is a T type. The tap position from 1.8 to 30MHz is controlled by seven relays, K101 to K103, and K105 to K108.

Position detection potentiometers VR101 and VR102 are linked to the spindles of variable capacitors VC1 and VC2 with a gear ratio of 1 : 1. Voltages of 0 to 5V (POD1 and POD2) are generated according to the positions of the variable capacitors. This position data is supplied to the CPU through the A/D converter by the digital unit, and is used as the reference voltage in the feedback control system, which is used for preset tuning and manual tuning. The same signal is also used for preset data and to signal the completion of tuning.

The potentiometers used here are not ones that rotate through 360 degrees. Since the rotation angle of each potentiometer is limited, the rotation range is from the minimum capacitance to the maximum capacitance, plus a little extra for headroom.

Through this control, like preset tuning, which will be described later, POD1 and POD2 are monitored by the microprocessor. If the lower limit voltage of 0.6V or the upper limit voltage of 4.2V is reached, the microprocessor detects that a variable capacitor is close to one of its limits. To return the voltage to the opposite side, APRE is switched high. For VC1, if the voltage is close to the lower limit with respect to PRE1, the voltage near the upper limit is output. If the voltage is close to the upper limit with respect to PRE1, the voltage near the lower limit is output.

If the variable capacitor voltage exceeds the specified limit, the variable capacitor is returned to the opposite limit. The other variable capacitor remains in the same position.

The direction of the motor is determined by the CPU unless auto tuning is performed with high APRE. The logic of PR11 to PR22 is the same as the logic of IC4 and IC5 (BA6109U2). The signal output from the digital unit passes through IC2 and IC3 (TC4066BP), and is input to IC4 and IC5 (BA6109U2).

		PR11	PR12	PR21	PR22
Motor 1	Normal rotation	H	L	-	-
	Reverse rotation	L	H	-	-
Motor 2	Normal rotation	-	-	H	L
	Reverse rotation	-	-	L	H

The motor stops in other cases.

- **Manual tuning**

Hold down the USB/LSB key and switch the power on. Select menu number 20 with the encoder, turn the display off with the band down key, and press the CLR key to return to the normal mode. Manual tuning is now possible.

The main encoder is used to control VC1, and the sub-encoder is used to control VC2. The capacitance of each variable capacitor changes from the maximum to the minimum when the encoder is turned about eight turns.

- **Preset tuning**

When auto or manual tuning stops, the position of the variable capacitor is stored in memory by the microprocessor as preset data for that band.

When the band is changed after tuning is performed in another band, APRE goes high, the motor is controlled by the microprocessor, and preset tuning is performed. During preset tuning, auto tuning or signal transmission is inhibited even if the AT TUNE switch is pressed or transmission becomes ready.

The initial preset data when the microprocessor is reset includes standard data for a 50 ohm load on each band.

## CIRCUIT DESCRIPTION

### Standby Control Timing

Standby control and timing are handled by the IF unit (X48-3080-00). The following control signals are used:

- SS : Standby switch. Active low.
- KEY : Keying signal from the keyer. Active low.
- TXI : Transmission inhibit signal from the micro-processor. Low when transmission is inhibited.
- PKS : Standby signal from the data communication terminal. Active Low.

The control output signals are as follows:

- TXB : 8 V during transmission
- RXB : 8 V during reception. Reversal of TXB.
- CKY : Keying output signal. Active High.
- RBC : Receive control signal. Active Low.

#### 1) Manual standby (except CW)

##### • RX → TX

If pin 9 (TXI) of the BK-SW module (X59-3880-00) is high when the standby switch is pressed and the SS line is grounded, Q2 in the module is turned on, and the base of Q49 is grounded via pin 10.

The collector of Q49 goes high, the signal enters pin 10 of the BK-IN module (X59-3870-00), passes through D1 in the module, enters pin 2 of the TRX module from pin 2 via R132, passes through the internal switch circuit, and TXB is output from pin 5. When TXB is high, RXB is low.

##### • CKY generation

Since CWB (8V in CW mode) is 0V in any mode other than CW, Q64 is turned off, Q44 a/2 is turned on, and the base of Q50 is grounded. Q50 is turned on, and a high signal from the collector of Q49 passes through the collector of Q50, D61, R316, and pin 5 of the BK-IN module (X59-3870-00), and enters pin 2 of IC2 c/4 in the module.

The high output signal from Q50 enters pin 5 of the DLY module, and pin 12 of the IC1 one-shot multi-vibrator in the module goes high. The  $\bar{Q}$  output from pin 9 of IC1 is low for 10 ms, then goes high. The  $\bar{Q}$  output enters pin 1 of IC2 C/4 in the module via pin 4 of the DLY module and pin 4 of the BK-IN module. Pin 3 of IC2 C/4 goes low 10 ms after the standby switch is pressed. The signal is inverted by inverter IC2 d/4, and is output from pin 9 of the module as the CKY signal.

The CKY signal then passes through the integration circuit, which rectifies the waveform, is directed to the ALC line, matched with the negative signal of the ALC, and used as the FET gate bias of the transmit IF stage.

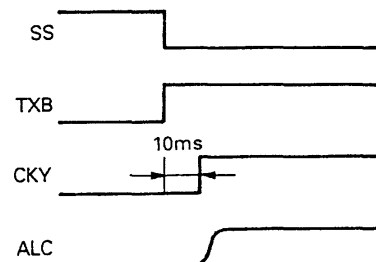

Fig. 13 TXB and CKY generation

##### • Transmission → Reception

When the standby switch is turned off, Q49 is turned off, and pin 10 of the BK-IN module goes low. Output from pin 4 of IC1 (b/6) is delayed 5ms after the standby switch is turned off because of the time constant circuit consisting of R1 and C1 between pin 2 of IC1 a/6 and pin 3 of b/6. Pin 2 of the TRX module goes low via pin D1 and D2 in the module. Therefore, TXB goes low 5 ms after the standby switch is turned off, and RXB goes high.

##### • CKY down

When the standby switch is turned off, the collector of Q50 goes low and pin 5 of the BK-IN module goes low. This causes the CKY line to go low at the same time. The CKY signal then passes through the integration circuit, which rectifies the waveform and reduces the ALC line voltage.

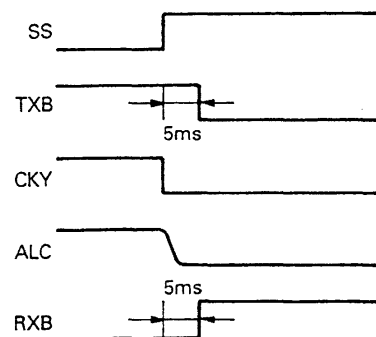

Fig. 14 TXB and CKY down

## CIRCUIT DESCRIPTION

### • RBC generation

When pin 2 of the BK-IN module goes low, pin 11 of IC1 e/6 and pin 13 of f/6 in the module go low. Because of the time constant circuit consisting of R5 and C3, the output from pin 10 of IC2 a/4 goes low 12.5ms after the standby switch is turned off, producing the RBC signal.

The RBC signal is applied to the base of the switching transistor that mutes the signal line of the IF unit. The signal is output to the signal line 12.5ms after the standby switch is turned off.

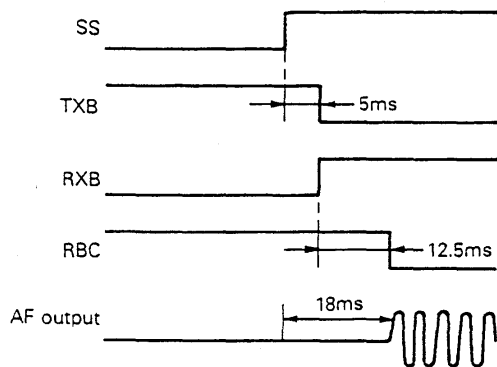

Fig. 15 RBC generation

### • PLL, DDS data and transmit/receive timing signal

It takes 10ms from the time the standby switch is grounded until the CKY signal is generated. It takes 12.5ms from the time RXB rises until the RBC line goes low. The PLL and DDS data from the microprocessor are switched, and the diode switch and analog switch are switched during that time to assure stable transmission and reception.

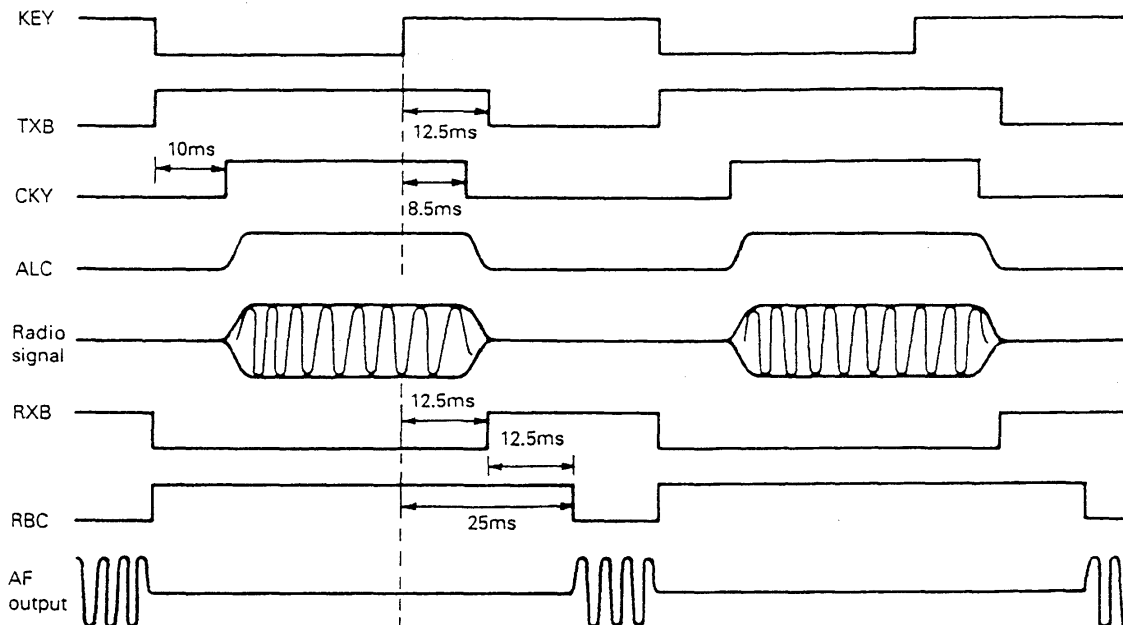

Fig. 16 Timing chart for full break-in

### 2) Full break-in operation timing

#### • TXB generation by closing the CW key

When a key is inserted into the jack, the switch in the jack is closed, the junction of R262 and R261 goes low, and Q44 is turned off.

When the key is depressed, the base of Q34 is grounded through R264 and D51, Q34 is turned on, and a high signal from CWB enters pin 8 of IC1 through the collector of Q34, D54, and pin 2 of the BK-SW module. The FULL/SEMI switch is grounded during full break-in, the switch for pins 8 and 9 of IC1 is turned on, and a high signal is output from pin 9 and enters pin 10 via D1. Since the VOX switch is also turned on during full break-in, pin 5 of the BK-SW module connected to the VOX switch goes high. The switch for pins 10 and 11 of IC1 are turned on, and Q3 connected to pin 11 of IC1 is turned on. If the TXI signal is high, Q49 is turned on, as in manual standby, and a high signal enters pin 10 of the BK-SW module from the collector of Q49 and exits from pin 2. Pin 2 of the TRX module goes high, and the TXB signal is generated.

#### • CKY generation

When the key is depressed, the collector of Q34 goes high, and Q44 is turned on via D40. Both Q49 and Q50 are turned on, and a high signal enters pin 5 of the BK-IN module through D61 and R316. The CKY signal rises 10 ms after the key is depressed in the same manner as for CKY generation at manual standby.

# TS-850S

## TS-850S

### CIRCUIT DE

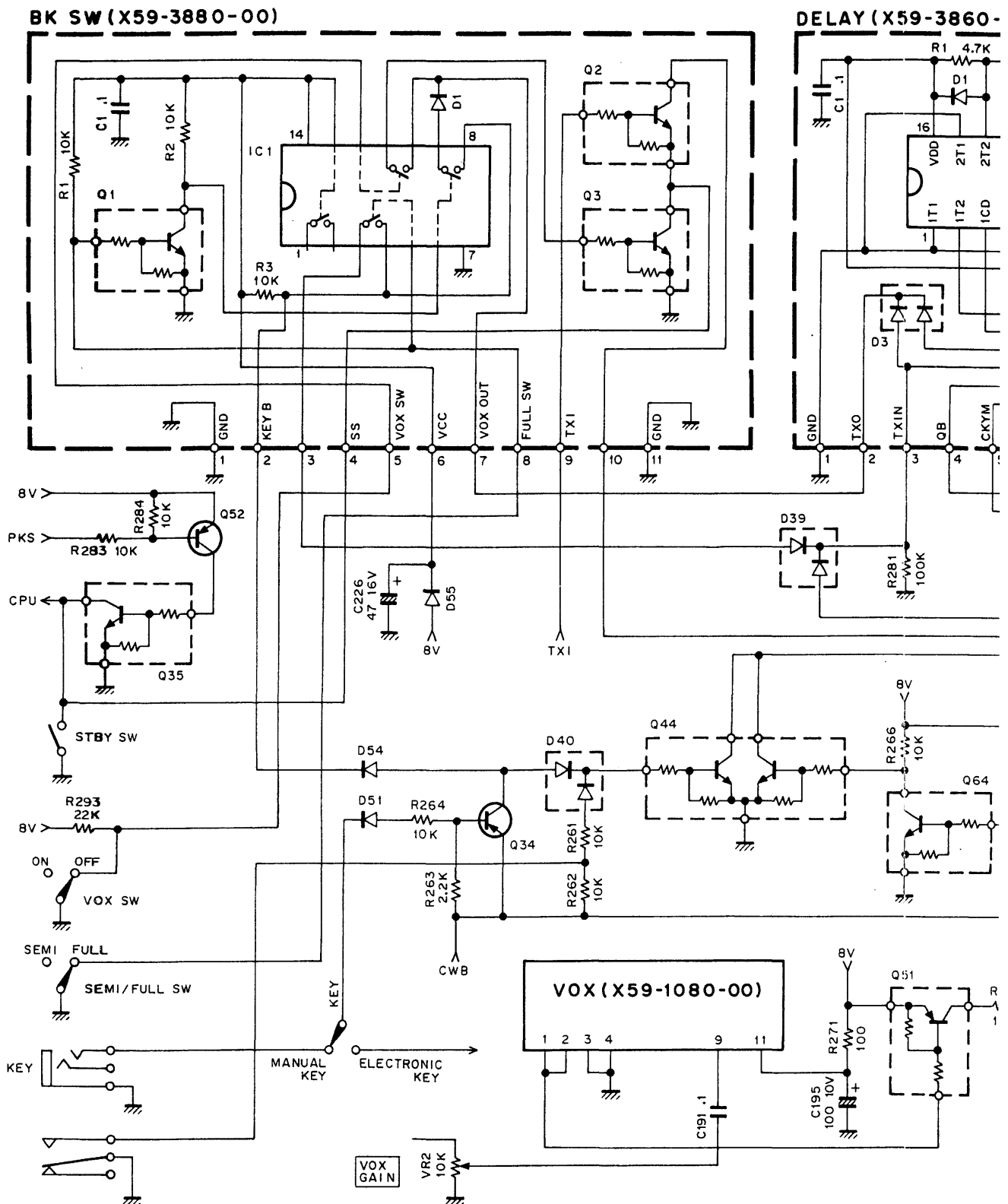
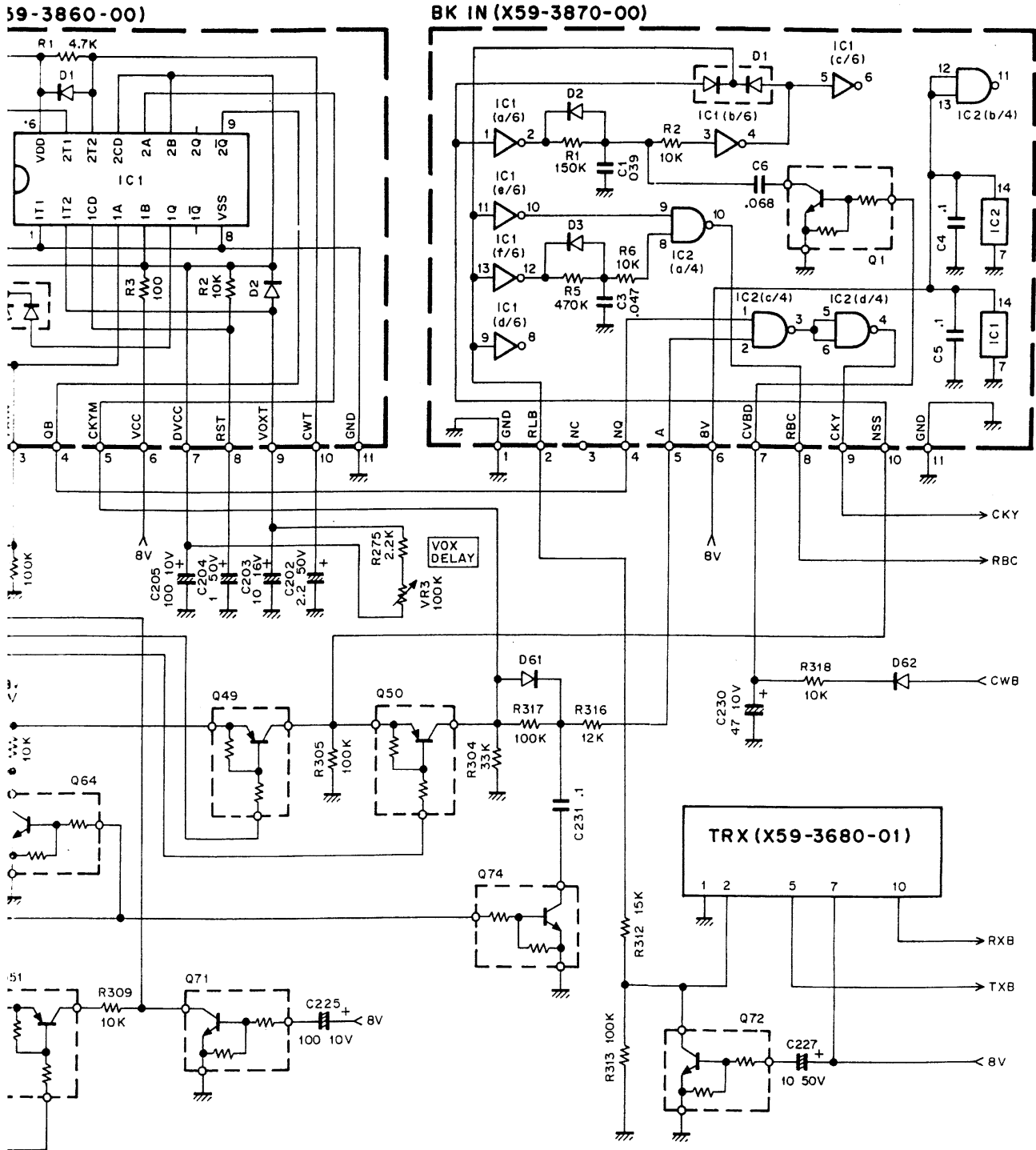

Fig. 17 Standb

## OS TS-850S CIRCUIT DESCRIPTION



Downloaded by   
  
Amateur Radio Directory

## CIRCUIT DESCRIPTION

### • Key up

When the key is up, pin 10 and pin 2 of the BK-IN module go low. TXB goes low, and RXB goes high. This differs from manual standby non-CW operation, since the signal passes from CWB in the CW mode through D62, R318, and pin 7 of the BK-IN module to turn on Q1. C6 is connected in parallel with C1, and the TXB delay time when the key is up is 12.5ms.

There is a switch circuit consisting of C230 and Q74 between D61 and R316 for the CKY output for Q50. In CW mode, Q74 is turned on, and C230 enters the output side of R317 to produce the necessary delay on key up. The time constant generated by the RC circuit is used to provide a correction of about 8.5ms when the key is up by raising the CKY waveform 10ms after the key is depressed to prevent deterioration of the waveform.

### • RXB and RBC generation

TXB changes from high to low, and RXB goes high 12.5ms after the key is up.

RBC operates the receive signal line with a delay of 12.5ms in the same way as for manual standby.

### 3) Timing for semi break-in operation

#### • TXB generation by key down

When the key is down, Q34 is turned on, and a high signal enters pin 2 of the BK-SW module via D54 in a similar manner as previously described for full break-in.

When the SEMI/FULL switch is set to semi break-in, pin 8 of the BK-SW module goes high, pin 5 of IC1 in the module goes high, and the switch for pins 3 and 4 of IC1 is turned on.

A high signal from D54 is output from pin 3 of the module via pins 4 and 3 of IC1, and enters pin 3 of the DLY module. This high signal makes pin 4 of IC1 in the module, terminal A of the one-shot multi, high. A constant high signal is output from the Q output from pin 6. The pulse width of the one-shot multi-vibrator can be varied with the VOX delay VR, and the time is the same as the delay time for VOX operation. The Q output of IC1 passes through D3, is output from pin 2, and enters pin 7 of the BK-SW module.

When VOX is on, pins 10 and 11 of IC1 in the module are turned on, the base of Q3 goes high, and Q49 is turned on in the same manner as previously described for full break-in to produce the basis for TXB. The CKY signal rises after a delay of 10ms in the same manner as for full break-in. The CKY signal rises after a delay of 8.5ms when the key is raised.

### 4) Standby from the data communication terminal

When the PKS terminal is grounded, Q52 and Q53 are turned on, and the SS line is grounded. Subsequent operations are the same as for manual standby in modes other than the CW mode.

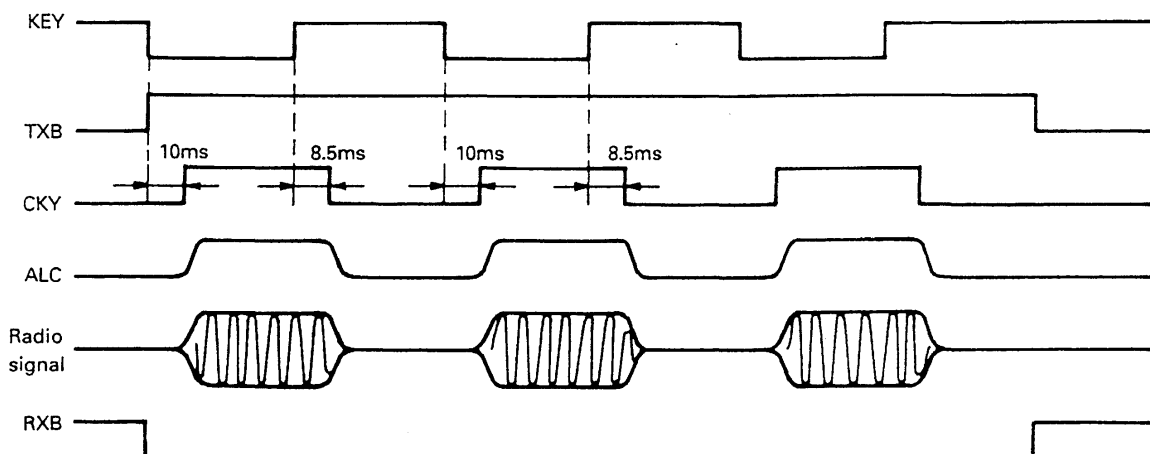

Fig. 18

## CIRCUIT DESCRIPTION

### Digital Control Unit

The TS-850 digital control circuit has a multiple chip configuration centered around IC6 ( $\mu$ PD78C10G), and consists of a 32K ROM (IC18, M27C256B), an 8K RAM

(IC13, TC5564APL), and an I/O port (IC1, IC3, MB89363B; IC2, CXD1095Q). This circuit controls about 50 different inputs and about 90 different outputs.

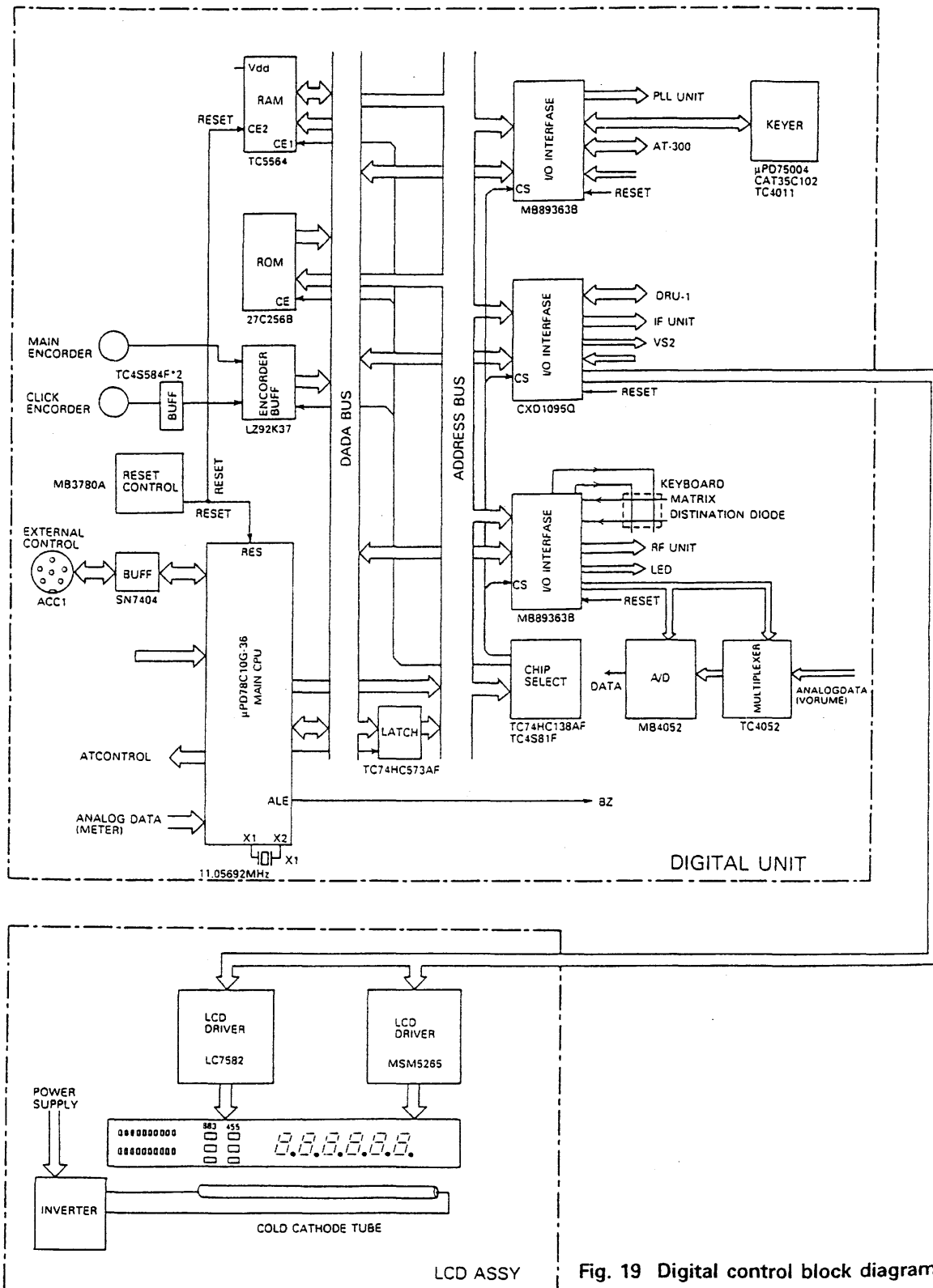

Fig. 19 Digital control block diagram



## CIRCUIT DESCRIPTION

### 1) Encoder circuit

The main encoder is a magnetic rotary encoder, and the click encoder is a contact-type rotary encoder.

Encoder pulses are applied to the gate array (IC14, LZ92K37), and read via the CPU bus. The gate array is selected by the Y3 line. Encoder CK1, CK2, or CK3 is

selected by A0. Encode data is output to D0 to D7 by making RD active when the chip select signal is active. IC15 and IC16 are used to rectify the waveform of the click encoder pulses.

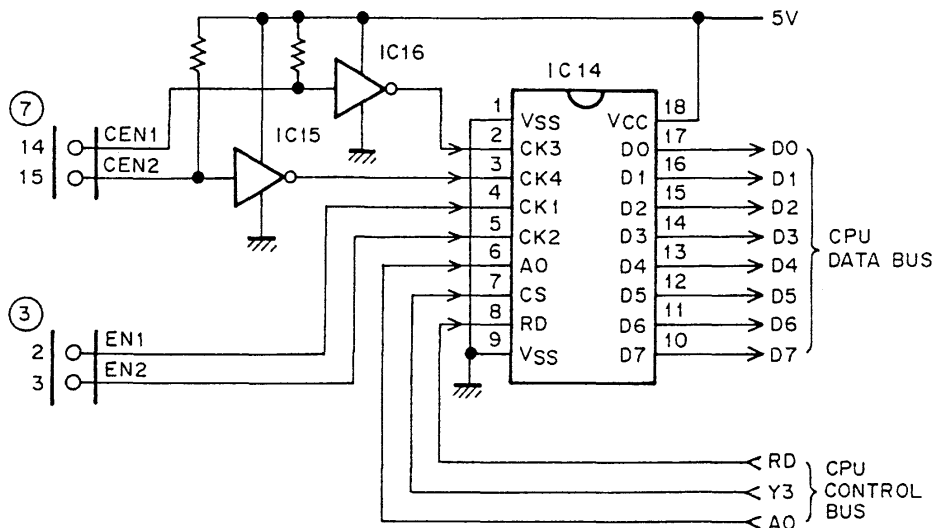

Fig. 20 Encoder circuit

### 2) System reset, RAM backup

The power supply voltage is detected by the power monitor IC (IC23, MB3780A). If the voltage is low, the IC outputs a RESET signal to the CPU and I/O port to stop operation and provide back up voltage to the RAM with an internal lithium battery.

When the power supply voltage returns to normal (including power on), the reset is released, the CPU and I/O port are initialized after the time constant set by C302, and operation resumes. The power to the RAM is supplied from the outlet.

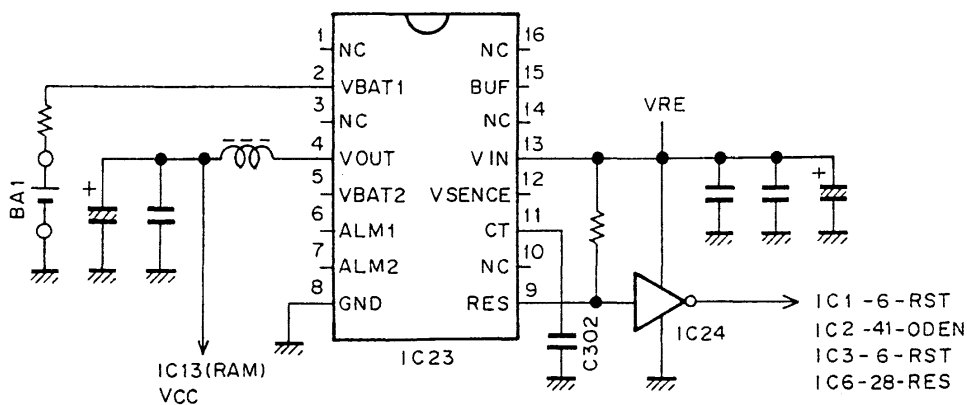

Fig. 21 System reset and RAM backup

## CIRCUIT DESCRIPTION

### 3) Address control

Since PD0 to PD7 of the main CPU have multiplexed address and data signals, the address signal is separated from the data signal by latching the address signal using the ALE signal from IC10 (TC74HC573AF). PF0 to PF7 become the high-order byte of the address.

The address signal of A12 to A15 is used as a chip select signal for each IC by address decoder IC11 (TC74HC138AF).

### Memory Map

0000	ROM	IC18 : M27C256B
8000	I/O	IC3 : MB89363B
A000	I/O	IC2 : CXD1095Q
B000	Encoder	IC14 : LZ92K37
C000	I/O	IC1 : MB89363B
E000	RAM	IC13 : TC5564APL
FFFF		

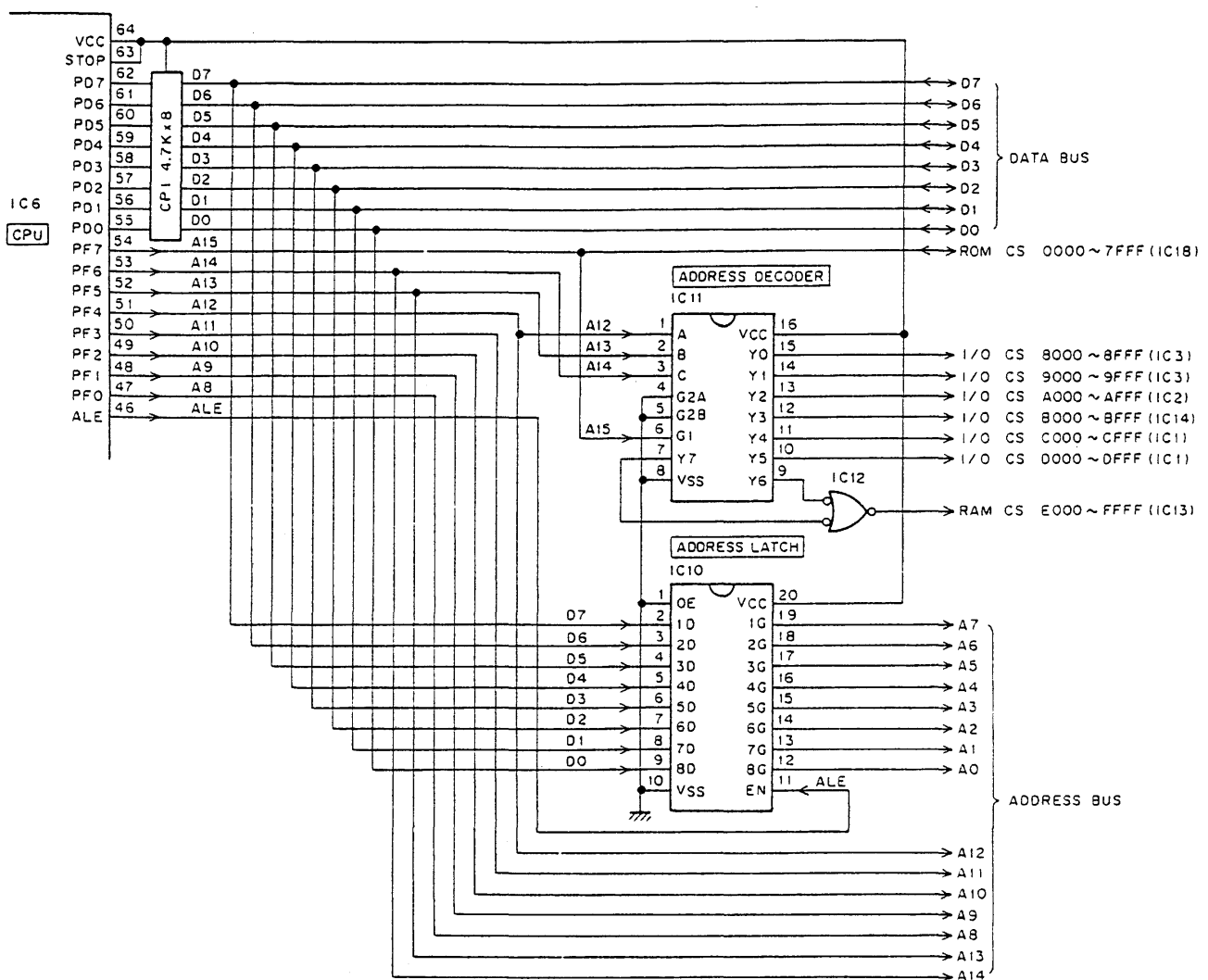

Fig. 22 Address control

## CIRCUIT DESCRIPTION

### 4) Analog signal input

The main microprocessor incorporates an 8-channel analog-to-digital (A/D) converter, and in addition, has IC4 (MB4056) (A/D) and IC5 (analog switch) for entering 14-channel analog signals. Incoming analog signals are converted to digital values, which are used as digital signals.

#### IC6 : $\mu$ PD78C10G (CPU)

Port	Signal	Description
AN0	ALM	ALC meter control voltage
AN1	SM	S-meter control voltage
AN2	CPM	Processor meter control voltage
AN3		Not used
AN4	VSRM	SWR meter control voltage
AN5		Not used
AN6	VFSM	RF meter control voltage
AN7		Not used

#### IC4 : MB4052 (A/D converter)

Port	Signal	Description
A0	CRU2	USB carrier point control voltage
	CRW2	Window alignment carrier control voltage
	CRL2	LSB carrier point control voltage
	POD2	AT variable capacitor 2 position control voltage
A1	LC2	Slope tune low-cut control voltage
	HC2	Slope tune high-cut control voltage
	RIT2	RIT/XIT control voltage
	POD1	AT variable capacitor 1 position control voltage
A2		Not used
A3	RMC2	Wired remote controller voltage

IC5 (TC4052) switches between the A0 and A1 signals.

### 5) Display

The TS-850 uses a transmission-type display with a negative LCD and a cold cathode tube. The LCD is lit by the LCD driver with a 50% duty cycle. The cold cathode tube is lit by the inverter, and the dimmer is operated by changing the duty cycle of the inverter. Data for the LCD driver is set by the clock (LCK), data (LDA), and enable (LEN1, LEN2) signals. The switching on and off of the LCD driver is controlled by BLK and INH.

### 6) PLL and DDS data

The TS-850 has 2 PLLs and 4 DDSs. The main microprocessor provides data to the PLL's and DDS's according to the displayed frequency. Ten PLL IC's provide unlock data signals. If one of the PLL's should unlock, the display indicates that the PLL is unlocked.

### 7) Key scan

The P1X port and P2X port of IC3 form a keyboard matrix. A key scan signal (a negative pulse) is output from the P2X port. One column corresponding to the P1X port is selected, and the state of that switch is read. When the switch at the intersection of the matrix is pressed, the P1X port bit goes low. Thus, which switch is pressed can be detected. The keys are software debounced.

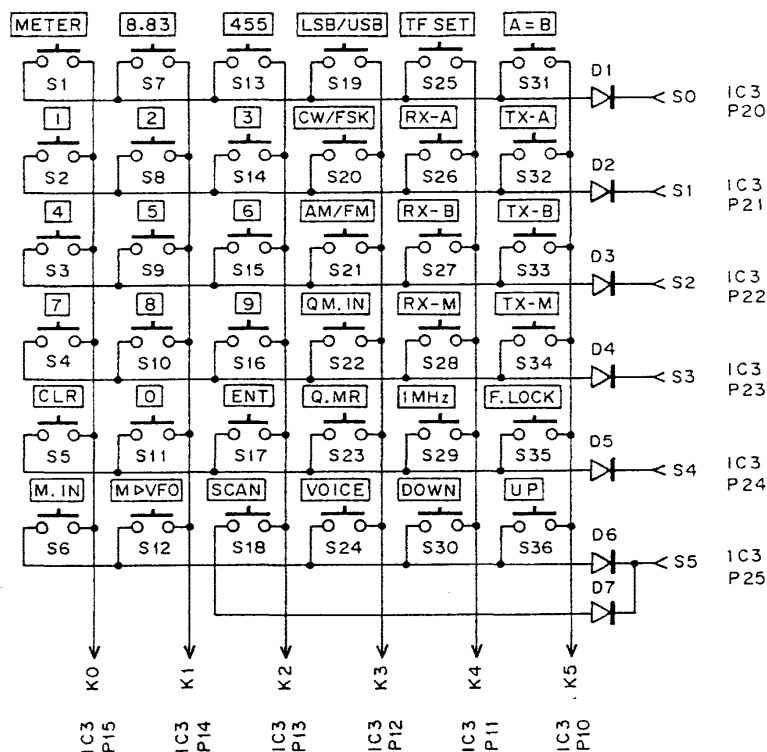

Fig. 23 Key-scan

## CIRCUIT DESCRIPTION

### 8) AT control

The AT is controlled by the variable capacitor position data (POD1, POD2, analog data input), motor normal/reverse rotation control (PR11, PR12, PR21, PR22), motor speed control (SPED), motor control switching (APRE), progressive wave for SWR calculation, and reflected wave voltage (VSFM, VSRM analog data input).

SPED controls the switching on and off of the motor rotation during AT tune and presetting by PWM with the duty cycle related to the SWR value.

APRE changes the motor normal/reverse rotation control to analog control for AT tune, and to digital control for presetting.

PR performs the motor normal/reverse rotation control and stop control when the motor normal/reverse control is performed digitally.

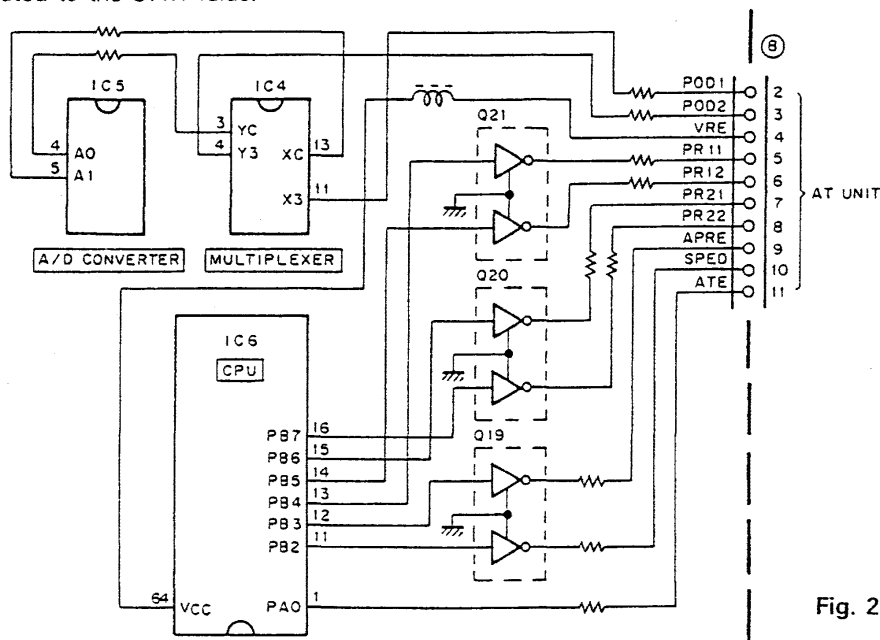

Fig. 24 AT control

### 9) IF filter switching

The IF filter switching signal from the digital unit is sent to the RF unit as 10-bit serial data. In the RF unit, serial-to-parallel converter IC8 (TC9174F) converts the serial data to parallel data to select the 8.83-MHz filter and the 455-kHz IF filter.

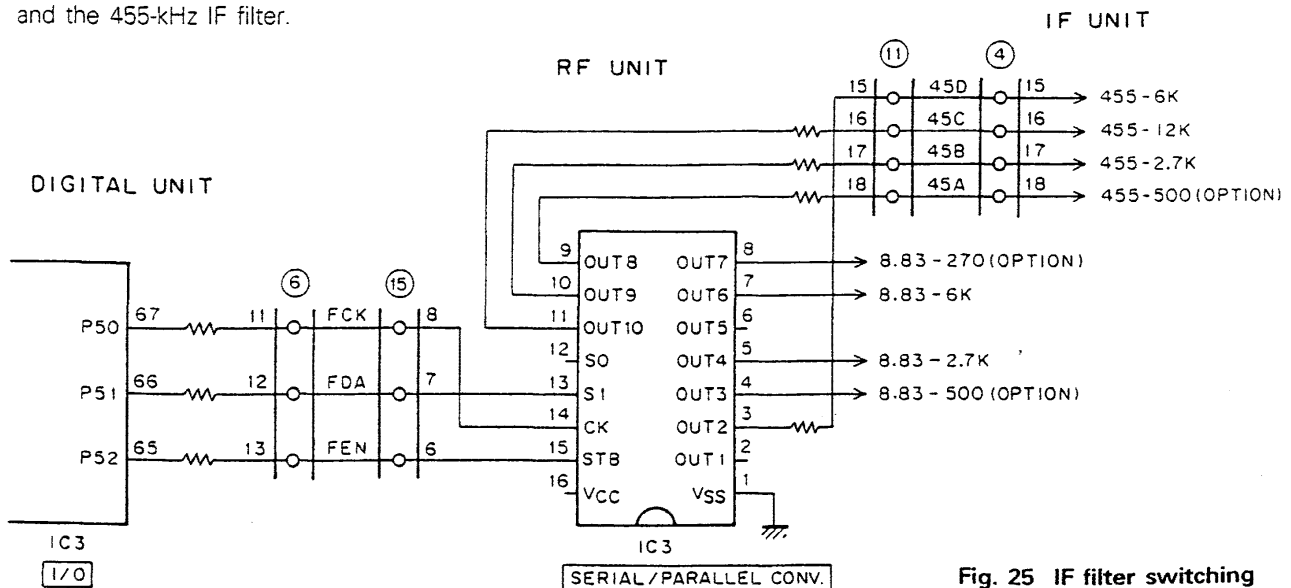

Fig. 25 IF filter switching

## CIRCUIT DESCRIPTION

### 10) Receive band-pass filter selection

The RF BPF signal (RB0 to RB3) from the digital unit is buffered by Q5 and Q6 of the digital unit, then forwarded to the RF unit. The RF unit obtains the RF BPF data using BCD-to-decimal decoders.

### 11) Transmit low-pass filter, AT band data

Transmitter system band data (TB0 to TB3) from the digital unit is buffered by Q10 and Q11 of the digital unit, then forwarded to the filter unit. The filter unit obtains TX LPF data and AT band data using BCD-to-decimal decoders.

### 12) PLL VCO data

The PLL unit switches the VCOs according to the VCO band data (VB0 to VB3) from the digital unit.

### 13) Electronic key control

The electronic key microprocessor is controlled by transferring 8-bit commands serially. The commands include automatic electronic key correction, automatic correction reversal, bug key mode setting, manual weight setting, and recording/playback setting.

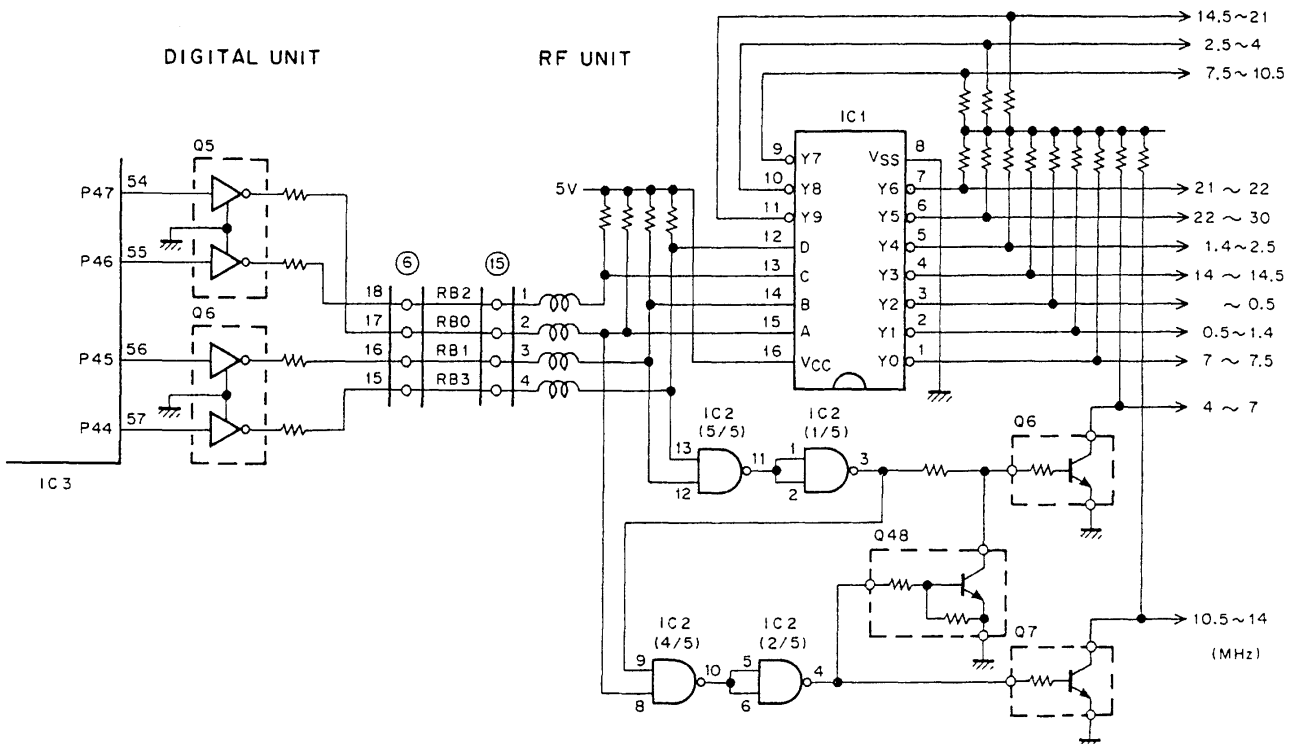

Fig. 26 Receiving BPF selection

### 14) Band data list

Frequency (MHz)	VB VCO-B				RB RX BPF				TB TX LPF			
	VB3	VB2	VB1	VB0	RB3	RB2	RB1	RB0	TB3	TB2	TB1	TB0
0.030000~ 0.499999	0	0	0	1	1	1	0	1	1	1	1	1
0.500000~ 0.999999	0	0	0	1	1	1	1	0	1	1	1	1
1.000000~ 1.499999	0	0	0	1	1	1	1	0	1	1	1	1
1.500000~ 1.620009	0	0	0	1	1	1	1	0	1	1	1	1
1.500000~ 1.705009 : K												
1.620010~ 1.999999	0	0	0	1	1	0	1	1	1	1	1	1
1.705010~ 1.999999 : K												
2.000000~ 2.499999	0	0	0	1	1	0	1	1	1	1	0	1
2.500000~ 2.999999	0	0	0	1	0	1	1	1	1	1	0	1
3.000000~ 3.499999	0	0	0	1	0	1	1	1	1	1	0	1
3.500000~ 3.999999	0	0	0	1	0	1	1	1	1	1	0	1

Note : VB, RB, and TB are logical values for the output pins of the I/O ports.

# TS-850S

## CIRCUIT DESCRIPTION

Frequency (MHz)	VB VCO-B				RB RX BPF				TB TX LPF			
	VB3	VB2	VB1	VB0	RB3	RB2	RB1	RB0	TB3	TB2	TB1	TB0
4.000000~ 4.499999	0	0	0	1	0	1	0	1	1	0	1	0
4.500000~ 4.999999	0	0	0	1	0	1	0	1	1	0	1	0
5.000000~ 5.499999	0	0	0	1	0	1	0	1	1	0	1	0
5.500000~ 5.999999	0	0	0	1	0	1	0	1	1	0	1	0
6.000000~ 6.499999	0	0	0	1	0	1	0	1	1	0	1	0
6.500000~ 6.999999	0	0	0	1	0	1	0	1	1	0	1	0
7.000000~ 7.499999	0	0	0	1	1	1	1	0	1	0	1	0
7.500000~ 7.999999	0	0	1	0	1	0	0	0	0	1	1	1
8.000000~ 8.499999	0	0	1	0	1	0	0	0	0	1	1	1
8.500000~ 8.999999	0	0	1	0	1	0	0	0	0	1	1	1
9.000000~ 9.499999	0	0	1	0	1	0	0	0	0	1	1	1
9.500000~ 9.999999	0	0	1	0	1	0	0	0	0	1	1	1
10.000000~10.499999	0	0	1	0	1	0	0	0	0	1	1	1
10.500000~10.999999	0	0	1	0	0	1	0	0	1	1	1	0
11.000000~11.499999	0	0	1	0	0	1	0	0	1	1	1	0
11.500000~11.999999	0	0	1	0	0	1	0	0	1	1	1	0
12.000000~12.499999	0	0	1	0	0	1	0	0	1	1	1	0
12.500000~12.999999	0	0	1	0	0	1	0	0	1	1	1	0
13.000000~13.499999	0	0	1	0	0	1	0	0	1	1	1	0
13.500000~13.999999	0	0	1	0	0	1	0	0	1	1	1	0
14.000000~14.499999	0	0	1	0	1	1	0	0	1	1	1	0
14.500000~14.999999	0	1	0	0	0	1	1	0	1	1	0	0
15.000000~15.499999	0	1	0	0	0	1	1	0	1	1	0	0
15.500000~15.999999	0	1	0	0	0	1	1	0	1	1	0	0
16.000000~16.499999	0	1	0	0	0	1	1	0	1	1	0	0
16.500000~16.999999	0	1	0	0	0	1	1	0	1	1	0	0
17.000000~17.499999	0	1	0	0	0	1	1	0	1	1	0	0
17.500000~17.999999	0	1	0	0	0	1	1	0	1	1	0	0
18.000000~18.499999	0	1	0	0	0	1	1	0	1	1	0	0
18.500000~18.999999	0	1	0	0	0	1	1	0	1	0	1	1
19.000000~19.499999	0	1	0	0	0	1	1	0	1	0	1	1
19.500000~19.999999	0	1	0	0	0	1	1	0	1	0	1	1
20.000000~20.499999	0	1	0	0	0	1	1	0	1	0	1	1
20.500000~20.999999	0	1	0	0	0	1	1	0	1	0	1	1
21.000000~21.499999	0	1	0	0	1	0	0	1	1	0	1	1
21.500000~21.999999	1	0	0	0	1	0	0	1	1	0	0	1
22.000000~22.499999	1	0	0	0	1	0	1	0	1	0	0	1
22.500000~22.999999	1	0	0	0	1	0	1	0	1	0	0	1
23.000000~23.499999	1	0	0	0	1	0	1	0	1	0	0	1
23.500000~23.999999	1	0	0	0	1	0	1	0	1	0	0	1
24.000000~24.499999	1	0	0	0	1	0	1	0	1	0	0	1
24.500000~24.999999	1	0	0	0	1	0	1	0	1	0	0	1
25.000000~25.499999	1	0	0	0	1	0	1	0	1	0	0	0
25.500000~25.999999	1	0	0	0	1	0	1	0	1	0	0	0
26.000000~26.499999	1	0	0	0	1	0	1	0	1	0	0	0
26.500000~26.999999	1	0	0	0	1	0	1	0	1	0	0	0
27.000000~27.499999	1	0	0	0	1	0	1	0	1	0	0	0
27.500000~27.999999	1	0	0	0	1	0	1	0	1	0	0	0
28.000000~28.499999	1	0	0	0	1	0	1	0	1	0	0	0
28.500000~28.999999	1	0	0	0	1	0	1	0	1	0	0	0
29.000000~29.499999	1	0	0	0	1	0	1	0	1	0	0	0
29.500000~30.000000	1	0	0	0	1	0	1	0	1	0	0	0

Note : VB, RB, and TB are logical values for the output pins of the I/O ports.

## CIRCUIT DESCRIPTION

### 15) Function of IC pins

#### • CPU : $\mu$ PD78C10G (IC6)

Port	Pin No.	Name	Function	I/O	Remarks
PA0	1	ATE	Internal AT connection determination	I	"L" = AT connection
PA1	2	ATA	AT AUTO/THRU switch	I	"L" = AUTO
PA2	3	XITS	XIT switch	I	"L" = Switch on
PA3	4	RITS	RIT switch	I	"L" = Switch on
PA4	5	EAT	Internal/external AT changeover switch	I	"L" = External, "H" = Internal
PA5	6	PDE	100W/10W filter determination	I	"L" = 100W, "H" = 10W
PA6	7	PT	Temperature protection input	I	"H" = Protection on
PA7	8	DATA IN	MB4052 serial data input	I	
PB0, PB1	9, 10		Not used		
PB2	11	SPED	Internal AT motor speed control	O	"H" = Motor on
PB3	12	APRE	Motor control analog/digital switching	O	"L" = Digital, "H" = Analog
PB4	13	PR11	Motor 1 rotation direction control	O	
PB5	14	PR12	Motor 1 rotation direction control	O	
PB6	15	PR21	Motor 2 rotation direction control	O	
PB7	16	PR22	Motor 2 rotation direction control	O	
PC0	17	TXD	Personal computer interface transmit data	O	
PC1	18	RXD	Personal computer interface receive data	I	
PC2	19	CTS	Personal computer interface transmit enable data	I	
PC3	20	RTS	Personal computer interface receive enable data	O	
PC4, PC5	21, 22		Not used		
PC6	23	BEEP	Beep output	O	
PC7	24		Not used		
AN0	34	ALM	ALC meter voltage	I	A/D input
AN1	35	SM	Signal meter voltage	I	A/D input
AN2	36	CPM	Processor meter voltage	I	A/D input
AN3	37		Not used	I	A/D input
AN4	38	VSRM	Reflected wave voltage	I	A/D input
AN5	39		Not used	I	A/D input
AN6	40	VFSM	RF meter (forward wave) voltage	I	A/D input
AN7	41		Not used	I	A/D input
PD0~PD7	55~62	AD0~AD7	CPU address/data multiplexed bus	I/O	
PF0~PF7	47~54	A8~A15	CPU high-order address bus	O	
RD	44	RD	Read signal	O	"L" = Acknowledge
WR	45	WR	Write signal	O	"L" = Acknowledge
ALE	46	ALE	Address/data separation signal	O	
NMI	25	NMI	Normal couple interrupt	I	Always "H"
INT1	26	INT1	External interrupt	I	Always "L"
M1, M0	27, 29	M1, M0	External memory mode	I	Always "H"
AVcc	43	AVcc	Power supply for A/D converter	I	
AVref	42	AVref	Reference power supply for A/D converter	I	
AVss	33	AVss	Ground for A/D converter	I	
X1, X2	30, 31	X1, X2	CPU clock crystal pin	I	
RES	28	RES	CPU reset pin	I	"L" = Reset
STOP	63	STOP	CPU stop pin	I	Always "H"

#### • Extended I/O : MB89363B (IC1)

Port	Pin No.	Name	Function	I/O	Remarks
P00	28	CWCK	Electronic keyer microprocessor data clock	O	
P01	27	CWDA	Electronic keyer microprocessor data	O	
P02, P03	26, 25		Not used		
P04, P05	23, 22		Not used		

## CIRCUIT DESCRIPTION

Port	Pin No.	Name	Function	I/O	Remarks
P06	21	TS	External AT control	O	
P07	20	TT	External AT control	O	
P10~P12	44~46	DPS3~DPS1	Optional filter installation switch	I	"L" = Installed
P13	47	SBSY	VS-2 busy	I	"H" = Busy
P14	48	UNL	PLL unlock signal	I	"L" = Unlocked
P15	49	VCK	DRU-2 installation signal	I	"H" = Installed
P16	50	PRS	Processor switch	I	"H" = Switch on
P17	51	ATS	AT start switch	I	"L" = Switch on
P20	38	MEA	Electronic keyer recording/playback busy	I	"H" = Busy
P21	39		Not used		
P22	40	BSY	Electronic keyer data transfer busy	I	"H" = Busy
P23	43	DPS4	Optional filter installation switch	I	"L" = Installed
P24	37	KEY	Electronic keyer keying input	I	"L" = Key on
P25	36	DBC	External DSP power on signal	I	"L" = Power on
P26	35	TS	External AT control	I	
P27	34	TT	External AT control	I	
P30~P33	77~80		Not used		
P34	1	RDC	Receive DSP switching	O	"L" = Analog, "H" = DSP
P35	2	TDC	Transmit DSP switching	O	"L" = Analog, "H" = DSP
P36, P37	3, 4		Not used		
P40	61	CASL	DDS register selection	O	"L" = Receive, "H" = Transmit
P41	60	ABSL	DDS register selection	O	"L" = Receive, "H" = Transmit
P42	59	TOC	Repeater tone control	O	"L" = Tone on
P43~P46	58~55	VB0~VB3	VCO band data	O	
P47	54	TU8C	TU-8 control	O	
P50	67	PCK	PLL, DDS control data clock	O	
P51	66	PDA	PLL, DDS control data	O	
P52	65	DLE4	DDS control data enable	O	
P53	62	DLE3	DDS control data enable	O	
P54	68	DLE2	DDS control data enable	O	
P55	69	DLE1	DDS control data enable	O	
P56, P57	70, 71	PLE2, PLE1	PLL control data enable	O	
DB0~DB7	12~19	DB0~DB7	Data bus	I/O	
RD	76	RD	Read signal	I	"L" = Acknowledge
WR	5	WR	Write signal	I	"L" = Acknowledge
RES	6	RES	Reset signal	I	"L" = Reset
A0, A1	31, 32	A0, A1	Port select signal	I	
CS0	29	CS0	Chip select signal	I	"L" = P0X to P2X selected
CS1	75	CS1	Chip select signal	I	"L" = P3X to P5X selected

### • Extended I/O : CXD1095Q (IC2)

Port	Pin No.	Name	Function	I/O	Remarks
PA0	54	VOA	DRU-2 control audio input/output switching	O	
PA1	55	VOB	DRU-2 control audio input/output switching	O	
PA2	56	RD	DRU-2 control command read	O	
PA3	59	WR	DRU-2 control command write	O	
PA4	60		Not used		
PA5	61	STR	VS-2 synthesis control	O	"H" = Audio synthesis
PA6	62	SCK	VS-2 control data clock	O	
PA7	63	SD	VS-2 control data	O	
PB0	64	EKS	Electronic keyer changeover switch	I	"L" = Electronic keyer on
PB1	3	MUP	Microphone up switch	I	"L" = Switch on
PB2	4	MDN	Microphone down switch	I	"L" = Switch on



## CIRCUIT DESCRIPTION

Port	Pin No.	Name	Function	I/O	Remarks
PB3	5	SS	Transmit/receive control signal	I	"L" = Transmission
PB4	6	VOX	VOX switch	I	"H" = Switch on
PB5	7	FULL	FULL/SEMI switch	I	"L" = FULL, "H" = SEMI
PB6	8	AIPS	AIP switch	I	"L" = Switch on
PB7	9	TXB	Transmit B signal	I	
PC0	11	CWC	CW mode	O	"H" = Mode selected
PC1	12	TXI	Transmission inhibit signal	O	"H" = Transmission inhibit
PC2	13	RSS	Transmission request signal	O	"H" = Transmission request
PC3	14	AMC	AM mode	O	"H" = Mode selected
PC4	15	RYC	FSK mode	O	"H" = Mode selected
PC5	16	FMC	FM mode	O	"H" = Mode selected
PC6	17	SSBC	SSB mode	O	"H" = Mode selected
PC7	18	ABK	AF blanking	O	"H" = Blanking
PD0	20	LCK	LCD control data clock	O	
PD1	21	LDA	LCD control data	O	
PD2	22	INH	LCD all-off	O	
PD3	23	BLK	LCD all-off	O	
PD4	24	LEN2	LCD control data enable	O	
PD5	27	LEN1	LCD control data enable	O	
PD6, PD7	28, 29		Not used		
PE0, PE1	49, 50	D1, D2	DRU-2 control data	I/O	
PE2, PE3	52, 53	D4, D8	DRU-2 control data	I/O	
D0~D7	30~32, 35~39	D0~D7	Data bus	I	
RD	44	RD	Read signal	I	"L" = Acknowledge
WR	43	WR	Write signal	I	"L" = Acknowledge
A0~A2	46~48	A0~A2	Port select signal	I	
CS	45	CS	Chip select signal	I	
ODEN	41	ODEN	Output disable	I	When reset, all ports become input ports

### • Extended I/O : MB89363B (IC3)

Port	Pin No.	Name	Function	I/O	Remarks
P00	28	AIL	AIP LED control	O	
P01	27	MHL	1MHz LED control	O	
P02	26	RXAL	Function LED control	O	
P03	25	RXBL	Function LED control	O	
P04	23	RXML	Function LED control	O	
P05	22	TXAL	Function LED control	O	
P06	21	TXBL	Function LED control	O	
P07	20	TXML	Function LED control	O	
P10~P15	44~49	K5~K0	Key matrix input	I	
P16, P17	50, 51		Not used		
P20~P22	38~40	S0~S2	Key matrix output	O	
P23	43	S3	Key matrix output	O	
P24~P26	37~35	S4~S6	Key matrix output	O	
P27	34	ATL	AT LED control	O	
P30, P31	77, 78	C1, C0	MB4052 channel selection	O	
P32	79	CS	MB4052 chip selection	O	
P33	80	CLK	MB4052 control clock	O	
P34	1	SELA	TC4052 channel selection	O	
P35	2	SELB	TC4052 channel selection	O	
P36, P37	3, 4		Not used		
P40~P43	61~58	TB0~TB3	TX LPF band data	O	

## CIRCUIT DESCRIPTION

Port	Pin No.	Name	Function	I/O	Remarks
P44,P45	57,56	RB3,RB1	RX BPF band data	O	
P46,P47	55,54	RB2,RB0	RX BPF band data	O	
P50	67	FCK	Filter selection data clock	O	
P51	66	FDA	Filter selection data	O	
P52	65	FEN	Filter selection data enable	O	
P53	62	RBK	RF blanking	O	"H" = Blanking
P54	68	ATPD	AT power down	O	"H" = Power down
P55	69	TPD	TUNE power down	O	"H" = Power down
P56	70	BPD	BAND power down	O	"H" = Power down
P57	71	AIP	AIP control	O	"L" = AIP on
DB0-DB7	12-19	DB0-DB7	Data bus	I/O	
RD	76	RD	Read signal	I	"L" = Acknowledge
WR	5	WR	Write signal	I	"L" = Acknowledge
RES	6	RES	Reset signal	I	"L" = Reset
A0,A1	31,32	A0,A1	Port select signal		
CS0	29	CS0	Chip select signal	I	"L" = P0X to P2X selected
CS1	75	CS1	Chip select signal	I	"L" = P3X to P5X selected

• Electronic keyer :  $\mu$ PD75P008GB (IC21)

Port	Pin No.	Name	Function	I/O	Remarks
P00	32	DOT	Dot input	I	
P01	31	SCK	Electronic keyer control data clock	I	
P02	30	DLY	Delay change	I	
P03	29	SI	Electronic keyer control data	I	
P10	37	SP	Serial/parallel input change	I	"L" = Serial
P11	36	DSH	Dash input	I	
P12	35	SPD	Speed clock input	I	
P13	33	EKS	Electronic keyer changeover switch	I	"L" = Electronic keyer on
P20	43	KEY	Keyer output	O	"H" = Keyer on
P21	42	RWL	Write LED control	O	
P22	41	MEA	Electronic keyer recording/playback busy	O	"H" = Busy
P23	40	BSY	Electronic keyer data transfer busy	O	"H" = Busy
P30	26	MDI	EEPROM data input	I	
P31	25	MDO	EEPROM data output	O	
P32	24	MSK	EEPROM data clock	O	
P33	23	MCS	EEPROM chip select	O	
P40-P43	16-13	WL0-WL3	Weight LED control	O	
P50-P53	11-8	B0-B3	Parallel data input (Manual wait)	I	Not used during serial control
P60,P61	7,6	CH0,CH1	Parallel data input (Channel selection)	I	Not used during serial control
P62	5	STA	Parallel data input (Recording/playback start)	I	Not used during serial control
P63	4	RWS	Parallel data input (Command write)	I	Not used during serial control
P70	3	FUL	Parallel data input (Full break-in correction)	I	Not used during serial control
P71	2	BKY	Parallel data input (Bug key mode)	I	Not used during serial control
P72	1	REV	Parallel data input (Wait correction reversal)	I	Not used during serial control
P73	44	AUTO	Parallel data input (Auto wait)	I	Not used during serial control
P80	28	M4K	EEPROM size select input	I	
P81	27	ACT	Weight LED active	I	
XT1, XT2	18, 19	XT1, XT2	Sub-clock input	I	
RES	20	RES	Reset input	I	
X1, X2	21, 22	X1, X2	Clock input	I	

## CIRCUIT DESCRIPTION

### Setting the Extended Functions

#### 1) Setting for full-Morse function

Every time you turn the POWER ON while pressing the VOICE key, the full-Morse function is turned ON/OFF alternatively.

#### • Morse for each key

AIP key	AON - AOF
8.83 key	TH8 - AM8 - SW8 - SN8 - CW8 (It does not function at repeat.)
455 key	TH4 - AM4 - SB4 - CW4 - CN4 (It does not function at repeat.) At FM, FW - FN (It does not function at repeat.)
REC1,2,3 key	R1BT, R2BT, R3BT
FINE key	FNON - FNOF
TUNE key	TNON - TNOF
CLR key	CL
ENT key	ETON - ETOF
1~9,0 key	1~9, 0
M.IN key	MSCR - MIN
MÆVFO key	MV
SCAN key	SCST - SCON
QUICK M.IN key	QMIN
QUICK MR key	QMRON - QMROF
A=B key	AEB
A,B,M.CH key	RXA, RXB, RXM, TXM, TXB, TXM
1MHz key	1MON - 1MOF
F.LOCK key	FLON - FLOF
DOWN key	DN (It does not function at repeat.)
UP key	UP (It does not function at repeat.)
RIT key	RTON - RTOF
XIT key	XTON - XTOF
AT TUNE key	ATST - ATED
PITCH key	PTON - PTOF
REV key	At CW, CWN - CER At FSK, FSKN - FSKR

#### 2) Setting for adjustment mode

Turning on while pressing F.LOCK key enters the menu mode under the adjustment mode.

Pressing the CLR key in the adjustment mode terminates the menu mode under the adjustment mode.

No other operation than pressing the CLR key or turning on again brings termination.

### Treat Construction

Model name	Treat	Mark	AT function	Model name	Treat	Mark	AT function
TS-850S	North America	K	○	TS-850S	Belgium	E3	○
		K2	-			E4	-
TS-850S	Australia	X	○	TS-850S	Other Areas	M	○
		X2	-			M2	-
TS-850S	Canada	P	○			M3	○*
		P2	-			M4	-*
TS-850S	Europe	E	○				
		E2	-				

\* : General coverage

#### • Menu for adjustment mode

Menu No.	Menu items	Status (Display)
00	CAR correction FSK pseudo SSB Possible FILTER exchange at transmission	
01	CAR-W correction Possible FILTER exchange at transmission	
02	0 adjustment for RIT/XIT volume	-1.28-1.27
03	WIDE adjustment for SLOPE TUNE HIGH CUT volume	-128-127
04	WIDE adjustment for SLOPE TUNE LOW CUT volume	-128-127
05	Forced ON/OFF for receiving DSP carrier	ON/OFF
06	Forced ON/OFF for transmitting DSP carrier	ON/OFF
	Full-ON of LCD	
	Full-OFF of LCD	
	LCD test 1	
	LCD test 2	
	LCD test 3	
	LCD test 4	

#### 3) Setting the extended functions

Turning on while pressing the SCAN key + TX-M.CH key enter the menu mode for extended functions.

Pressing the CLR key in the menu mode of the extended functions terminates the menu mode of the extended functions.

No other operation than pressing the CLR key or turning on again brings termination.

The menu items of the extended functions are shown in the table.

#### • Menu for extensive functions

Menu No.	Menu items	Status (Display)	Initial status
00	Indicates checksum of ROM	Indicates checksum of ROM in the range of 0000-FFFF.	
01	Turns ON/OFF FILTER exchange at transmission	ON/OFF	OFF
02	Forced ON/OFF AT power down	ON/OFF	OFF
03	AT non-stop mode ON/OFF	ON/OFF	OFF
04	MODE, FILTER of band memory ON/OFF	ON/OFF	ON
05	Power ON; ON/OFF for HELLO Morse	ON/OFF	OFF
06	Turns ON/OFF LCD full-ON mode at power ON	ON/OFF	OFF
07	Turns ON/OFF DDS subtone	ON/OFF	ON
08		ON/OFF	OFF

# TS-850S

## DESCRIPTION OF COMPONENTS

### RF UNIT (X44-3120-00)

Ref. No.	Use/Function	Operation/Condition/Compatibility
Q1	RX RF amplifier	22-30MHz
Q2,3	RX RF amplifier	22MHz or less
Q4	DC switch	K4 control
Q5	TX RF amplifier	Drive output
Q6,7	DC switch	
Q8-11	RX 1st mixer	frx → 73.05MHz
Q12	Ripple filter	
Q13	IF amplifier	73.05MHz
Q14	Buffer	
Q15	Mixer	73.05MHz → 8.83MHz for monitor
Q16,17	RX 2nd mixer	73.05MHz → 8.83MHz
Q18	RF amplifier	NB RF output
Q19	DC switch	NB gate
Q20	TX IF amplifier	8.83MHz
Q21	RF amplifier	For monitor, 8.83MHz
Q22	DC switch	
Q23,24	TX 2nd mixer	8.83MHz → 73.05MHz
Q26,27	TX 3rd mixer	73.05MHz → ftx
Q28	RF amplifier	1st local amplifier
Q29	DC LPF	ACL keying
Q30,31	DC switch	On when ARPD or PT or TPD are "H"
Q32	DC switch	On when S1 is on or BPD is "H" and Q30 is off
Q33	DC switch	On when PDE is "L"
Q34	DC switch	On when Q31 is on
Q35	DC switch	On when TPD is on
Q36-38	DC amplifier	ALC amplifier
Q39	DC amplifier	SWR protection
Q40,41	DC amplifier	ALC amplifier
Q42	DC switch	
Q43	DC switch	TXB → RL
Q45-48	DC switch	
Q49	RF switch	OPn when TX
Q50	DC switch	On when PDE is "L"
Q51	DC switch	On when Q50 is on
Q52	DC switch	On when Q45 is on and Q51 is off
Q501	AF switch	On when VOB is "H"
Q502	DC switch	On when VOB is "H"
Q503	AF switch	On when VOA is "H" and VOB is "L"
Q601-603	RF amplifier	8.83MHz NB
Q604	DC amplifier	NB AGC
Q605	DC switch	On at noise pulse (NB1, NB2)
Q606	DC switch	On at noise pulse (NB2)
Q607	DC switch	On at noise pulse (NB1, NB2)
Q608	DC switch	On at noise pulse (NB2)
Q609	AF amplifier	FM microphone amplifier
Q610	AF switch	FM microphone mute
Q611	DC switch	On when Q612 is on
Q612	DC switch	On when Q613 is off
Q613	DC switch	On when NFB is "H"

## DESCRIPTION OF COMPONENTS

Ref. No.	Use/Function	Operation/Condition/Compatibility
IC1,2	BCD $\leftrightarrow$ decimal	RF BPF selection
IC3	Serial data $\rightarrow$ decimal	8.83MHz and 455kHz IF filter selection
IC4	RF detection	TX monitor
IC5	Meter amplifier	VSF, VSR, ALC processor
IC601	Delay	Noise cycle discrimination
IC602	NAND	Noise cycle discrimination
IC603	Analog switch	NFM changeover
D1,2	Spike absorption	
D3	RF switch	On when RX
D4~27	RF switch	BPF switch
D28	DC switch	
D29	DC switch	On when 22~30MHz BPF is selected
D30	Zener diode	4.7V, VCC of IC1 and IC2
D31	RF switch	On whe TX
D32	Reverse current prevention	
D33,34	RF switch	On when AIP is on
D35,36	RF switch	On when 22MHz or more RF amplifier is selected
D37,38	RF switch	On when 22MHz or less RF amplifier is selected
D39	Reverse current prevention	
D40~43	RF switch	Off when NB blanking
D44	RF switch	On when RX
D45~56	RF switch	8.83MHz filter changeover
D57	RF switch	On when RX
D58	RF switch	ON when TX
D59	Zener diode	4.7V, VCC of IC3
D60	RF switch	On when TX
D61,62	Reverse current prevention	
D63	LED	Constant voltage source
D64	RF switch	On when RX
D65,66	RF switch	On when TX
D67~71	Reverse current prevention	
D73	Zener diode	Lowers the output power during reduced voltage
D74	LED	Constant voltage source
D75	Zener diode	3.6V voltage shift
D76	Reverse current prevention	
D77	Zener diode	12V external ALC voltage shift
D78	Reverse current prevention	
D79	Spike absorption	
D80~85	Reverse current prevention	
D86	RF switch	LO2 TX/RX changeover
D87,88	Reverse current prevention	
D89	CAR level adjustment	
D90	Spike absorption	
D91,92	Reverse current prevention	
D93,94	Voltage limiter	
D601	Detection	
D602~604	Reverse current prevention	
D605	Zener diode	-6.2V

# TS-850S

## DESCRIPTION OF COMPONENTS

### FINAL UNIT (X45-1470-02)

Ref. No.	Use/Function	Operation/Condition/Compatibility
Q1	Pre-drive amplifier	Wide-band amplification of HF band
Q2,3	Drive amplifier	Push-pull wide-band amplification of HF band
Q4,5	Final amplifier	Push-pull wide-band amplification of HF band
Q6	Supply of bias for drive	Temperature compensation of drive
Q7	Supply of bias for final	Temperature compensation of final
Q8	Switching	
Q9	Temperature detection	1/2 : Power down 2/2 : Fan motor operation
D1	Temperature compensation	Temperature sensing of pre-drive
D2	Temperature compensation	Temperature sensing of drive
D3	Temperature compensation	Temperature sensing of final
D4	Absorption of surge voltage	For fan motor

### DIGITAL UNIT (X46-308X-XX) 0-11 : K,K2,P,P2 0-21 : M,M2 0-22 : M3,M4 0-71 : X,X2 2-71 : E,E2 2-72 : E3,E4

Ref. No.	Use/Function	Operation/Condition/Compatibility
Q1	Signal switch	TU-8 control
Q2	Signal switch	Mode signal (FM, AM)
Q3	Signal switch	Mode signal (SSB, FSK)
Q4	Signal switch	Mode signal (CW), TX indication signal (TXI)
Q5,6	Signal switch	RX band signal (RB0-RB3)
Q7,8	Signal switch	Power down signal (BPD, TPD, ATPD)
Q9	Signal switch	AIP signal
Q10,11	Signal switch	TX band signal (TB0-TB3)
Q12,13	Signal switch	AT-300 control, input (TS, TT)
Q14,15	Signal switch	AT-300 control, output (TS, TT)
Q16	Signal switch	Transmission control (SS line)
Q19-21	Signal switch	AT control (PR11, PR12, PR21, PR22, APRE, SPED)
Q22	Signal switch	AT relay control (ATA)
Q23	Signal switch	Transmission control (KEY line)
Q24,25	Signal switch	Select control of signal channel (RDC, TDC)
Q26	Signal switch	DRU-1 control (STBY)
IC1,3	I/O port	8 bit x 3 x 2
IC2	I/O port	8 bit x 4, 4 bit x 1
IC4	Multiplexer	A/D data switching
IC5	A/D converter	8 bit, 8 channel
IC6	CPU	8 bit microprocessor
IC10	Address latch	Latches multiplexer address/data
IC11	Address decoder	Converts the address signal into a chip select signal for each IC
IC12	Chip select decode	Chip select combination for RAM
IC13	RAM	8 bit x 8192 (8 K byte)
IC14	Encoder gate array	Pulse count of encoder
IC15,16	Schmitt trigger	Encoder chattering absorption
IC17	Inverter	Buffer for personal computer interface input/output
IC18	ROM	8 bit x 32768 (32 K byte)
IC20	NAND gate	Electronic keyer speed oscillator
IC21	CPU	Electronic keyer control 4 bit microcomputer
IC22	EEPROM	Electronic keyer message memory EEPROM (1 bit x 2048)
IC23	Select system reset back up	Generate reset signal, select back up power of the IC13 RAM
IC24	Inverter	Reverse reset logic
IC25	Regulator	14V → 8V
IC26	Regulator	8V → 5V
IC601,602	Regulator	14V → 8V

## DESCRIPTION OF COMPONENTS

Ref. No.	Use/Function	Operation/Condition/Compatibility
D1	Protective diode	Protection from SEMI/FULL switch
D2	Protective diode	Protection from AT START switch
D3,4	Protective diode	Protection from MIC DOWN/UP switch
D5	Protective diode	Protection from SS line
D6-12	Switching	Destination selection
D14	Protective diode	Protection from AT THRU/AUTO switch
D17	protective diode	AT THRU/AUTO switch line overshoot protection
D18,19	Protective diode	Protection from DASH/DOT switch
D20	Protective diode	Protection from KEY line
D22	Protective diode	Protection from DBC line
D601	Protective diode	Reverse power connection prevention
D602	Surge absorption	For final fan motor
D603	Voltage stability	Voltage effect prevention during fan starting

### IF UNIT (X48-3080-00)

Ref. No.	Use/Function	Operation/Condition/Compatibility
Q1,2	3rd receiving mixer	Conversion of 8.83MHz to 455kHz
Q3	Gain down for 28MHz	
Q4	Receiving IF amplifier	
Q5	LO3 amplifier	8.375MHz
Q6,7	1st transmission mixer	Conversion of 455kHz to 8.83MHz
Q8	Speech processor amplifier	
Q9	Transmission IF buffer	455kHz
Q10,11	Differential amplifier for notch	
Q12	Buffer for notch	
Q13-15	Receiving IF amplifier	455kHz
Q16	Receiving IF buffer	AM detection, AGC, and squelch
Q17	Buffer for AM detection	
Q18	AGC amplifier	
Q19-21	Squelch amplifier	
Q22	FM detection output low-pass filter	De-emphasis
Q23,24	FM S-meter amplifier	
Q25	CAR buffer	455kHz
Q26	Drive amplifier for modulation	
Q27	Squelch gate	
Q28	Monitor muting	
Q29-31	Side-tone switching	
Q32	Data amplifier	Amplifier for rear input
Q33	VOX amplifier	VOX gain
Q34	Keying	On at key down during CW mode
Q35	Switching	Stand-by for packet
Q36	Switching	RXB during other than FM mode, changeover of 455kHz filter
Q37	Switching	RXB during FM mode, changeover of 455kHz filter
Q38	Switching	When TDC is low, TDB is 8V
Q39	Switching	8V except transmission FM mode, muter signal of FM MIC amplifier
Q40	Switching	Voltage for RF gain except FM mode
Q41	Switching	Switching when AF AGC off
Q42	Switching	Changeover of HI BST
Q43	Switching	Squelch switching for packet
Q44	Switching	Keying when CW mode, key down except CW mode
Q45	Switching	Switching of RYB and SSBB
Q46	Switching	Switching of AMB and FMB

# TS-850S

## DESCRIPTION OF COMPONENTS

Ref. No.	Use/Function	Operation/Condition/Compatibility
Q47	Switching	8V when FM narrow mode
Q48	Switching	Switching of CWB
Q49,50	Switching	
Q51	Switching	Output of VOX module
Q52	Switching	Power source for muting of microphone when PKS is low
Q53-55	Switching	Inversion of FMB
Q56	Switching	Switching of squelch
Q57	Switching	For AGC on/off
Q58	Switching	Muting of reception
Q59	Switching	Switching when FM AGC off
Q60	Switching	Inversion of FMB
Q61	Switching	Inversion of RDB
Q62	Switching	Switching of IC5
Q63	Switching	Gain down when Am mode
Q64	Switching	
Q65	Switching	Inversion of SSBB and RYB
Q66	Switching	Stop carrier when receiving or when transmitting for DSP use
Q67	Switching	Switching of HI BST
Q68	Switching	VOX off when CW or FSK mode
Q69	Switching	Muting of input of FM IC when receiving
Q70	Active low-pass filter	Low-pass filter of IF output for DSP-100
Q71,72	Switching	Prevents transmission when power is on
Q73	Switching	RDB is 8V when RDC is low
Q74	Switching	Prevents transmission during mode changeover
IC1	Limiter	For speech processor
IC2	FM IF stage and DET	
IC3	Balanced modulator	
IC4	Product detector	
IC5	Receive audio muting	
IC6	Audio power amplifier	
IC7	Audio pre-amplifier	For monitor
IC8	Receive audio pre-amplifier	For monitor
IC9	Voltage select for RF gain	FM and the other
IC10	Time constant select of AGC	
IC11	Selector	For each mode of receiving audio signal
IC12	Selector	For DSP IN/OUT and through of receiving audio signal
D1	Switching	Changeover of transmission/reception of LO3
D2	Switching	Changeover of transmission/reception of 455kHz IF filter (reception side)
D3,4	Switching	Changeover of 455kHz IF filter
D5,6	Switching	Changeover of transmission/reception of 455kHz IF filter (except FM reception)
D6-9	Switching	Changeover of 455kHz IF filter
D10	Switching	Changeover of transmission/reception of 455kHz IF filter (FM reception)
D11,12	Switching	Changeover 455kHz IF filter
D13,14	Switching	Changeover of transmission/reception of 455kHz IF filter (transmission side)
D15,16	Switching	Bypass of speech processor
D17	Switching	When speech processor is on
D18,19	Switching	Through circuit for transmission of 455kHz IF filter
D20	For notch tuning	
D23	Switching	Changeover of squelch SSB and FM
D24	Detection	FM S-meter detection
D27	Reverse current prevention	Upsets carrier balance during AM mode
D28	pin diode	Carrier level adjustment
D29	Reverse current prevention	SSBB and carrier volume



## DESCRIPTION OF COMPONENTS

Ref. No.	Use/Function	Operation/Condition/Compatibility
D30	Reverse current prevention	Threshold squelch
D31	Detection	AGC squelch detection
D32	Detection	AM detection
D33	Reverse current prevention	Matching of AGO and FMB for AGC circuit off
D34	Reverse current prevention	CWB, RYB matching $\text{AE}$ RCB
D35	Reverse current prevention	CWB, RSB matching $\text{AE}$ CRSB
D36	Reverse current prevention	RYB, SSBB matching $\text{AE}$ RSB
D37	Reverse current prevention	Matching with inverse of MONS and RSB
D38	Reverse current prevention	Matching of RCB and TDB
D39	Reverse current prevention	Matching of VOX output and BK-SW output
D40	Reverse current prevention	Key lowering when key is not inserted
D41	Reverse current prevention	Matching of RBC and TXB
D42	Reverse current prevention	Stops operation of VOX when CW and FSK mode
D43	Reverse current prevention	Side-tone keying
D44	Reverse current prevention	Matching of RXB and TDB
D46	Switching	Changeover of analog modulator output and modulated output of DSP-100
D47	Reverse current prevention	Side-tone keying
D48	Detection	FM squelch detection
D49	Reverse current prevention	Matching of RXB and 8V other than FM mode
D50	Reverse current prevention	Squelch gate switching
D51	Reverse current prevention	Key line
D52	Reverse current prevention	Switching of monitor mute (RXB)
D53	Reverse current prevention	Matching of 45A selection and FM narrow switching
D54,55	Reverse current prevention	
D57	Switching	Switching of transmission carrier
D58	Switching	During transmission
D59	Limiter	Limiter for FM S-meter output
D60	Reverse current prevention	Noise sound countermeasures when power is on
D61,62	Reverse current prevention	Momentary transmission countermeasure when power is on
D63	Constant voltage	Stabilization of power of FM IC

### PLL UNIT (X50-3130-00)

Ref. No.	Use/Function	Operation/Condition/Compatibility
Q1	VCO1-A	73.08~88.05MHz
Q2	VCO1-B	80.55~87.55MHz
Q3	VCO1-C	87.55~94.55MHz
Q4	VCO1-D	94.55~103.55MHz
Q5	Switching	VCO1-A changeover
Q6	Switching	VCO1-B changeover
Q7	Switching	VCO1-C changeover
Q8	Switching	VCO1-D changeover
Q9	Active LPF	Comparison : 500kHz
Q10,11	Active LPF	
Q12	Buffer	VCO1-A~D output, 73.08~103.05MHz
Q13	Buffer	IC6 mixer input, 73.08~103.05MHz
Q14	Buffer	LO1 output, 73.08~103.05MHz
Q15	Buffer	PLL IC3 input, 18.03~48.00MHz
Q16	Amplifier	PLL IC3 input, 18.03~48.00MHz
Q17	Amplifier	LO2 output, 64.22MHz
Q18~22	Active LPF	Comparison : 20kHz (5kHz when FM mode)
Q21	Reference oscillator	Reference signal : 20MHz
Q22	Buffer	Reference oscillator

# TS-850S

## DESCRIPTION OF COMPONENTS

Ref. No.	Use/Function	Operation/Condition/Compatibility
Q23	Amplifier	Reference output
Q24	Tripled circuit	10MHz x 3 = 60MHz
Q25	Amplifier	Frequency divider input
Q26	Active LPF	10kHz reference output
Q27	Switching	Low when unlock output
Q28	Switching	Power for TU-8
IC1	Mixer	1 : 55.05~55.55MHz output    2 : 60MHz input    5 : 4.45~4.49MHz input
IC2	AVR	+9V low drop-out
IC3	PLL	2,3,4 : Frequency division ratio input    5 : 10MHz input    7 : Lock voltage output 8 : Unlock output, Unlock : "H"    12 : 64.22MHz input
IC4	PLL	2,3,4 : Frequency division ratio input    5 : 10MHz input    7 : Lock voltage output 8 : Unlock output, Unlock : "H"    12 : 18.03~48.00MHz input
IC5	AVR	+5V
IC6	Mixer	5 : 73.08~103.05MHz input    11 : 55.05~55.55MHz input 13 : 18.03~48.00MHz output
IC7,8	Frequency divider	1/2 x 2, 1/5 x 2
D1	Vari-cap diode	VCO1-A
D2	Switching	VCO1-A output
D3	Vari-cap diode	VCO1-B
D4	Switching	VCO1-B output
D5	Vari-cap diode	VCO1-C
D6	Switching	VCO1-C output
D7	Vari-cap diode	VCO1-D
D8	Switching	VCO1-D output
D9	Switching	Unlock signal

### CAR UNIT (X50-3140-00)

Ref. No.	Use/Function	Operation/Condition/Compatibility
Q1	Buffer	D/A buffer
Q2	Buffer	DLO1 buffer
Q3	Amplifier	20MHz f <sub>STD</sub>
Q4	Buffer	D/A buffer
Q5,6	Switching	Chopper
Q7	Buffer	Output buffer for chopper
Q8,9	Amplifier	LO3
Q10	Buffer	D/A buffer
Q11,12	Switching	Chopper
Q13	Buffer	Output buffer for chopper
Q14,15	Amplifier	MCAR
Q16	Buffer	STON
Q17	Buffer	D/A buffer
Q18	Buffer	CAR
Q19	Level conversion	RTK
IC1	DDS	DLO1
IC2	DDS	LO3 sub-tone modulation
IC3	DDS	MCAR, STON, sub-tone generation
IC4	DDS	CAR, FSK modulation
IC5	Division	20MHz → 4MHz
IC6	Mixer	0.95~0.45MHz → 4.95~4.45MHz
IC7,8	Regulator	+5V
IC9	Buffer	20MHz f <sub>STD</sub>

## DESCRIPTION OF COMPONENTS

### FILTER UNIT (X51-3100-00)

Ref. No.	Use/Function	Operation/Condition/Compatibility
Q1	Relay driver	10F relay
IC1	Band data decoder	
IC2	Relay driver	
D1	High-frequency rectification	Reflected wave rectification
D2	High-frequency rectification	Forward wave rectification
D3	Voltage stabilization	5V stabilization
D4,5	LPF changeover	18/21MHz common use
D6,7	LPF changeover	24/28MHz common use
D8	Relay surge absorption	1.6~2.0MHz LPF relay
D9	Relay surge absorption	2.0~4.0MHz LPF relay
D10	Relay surge absorption	4.0~7.5MHz LPF relay
D11	Relay surge absorption	7.5~10.5MHz LPF relay
D12	Relay surge absorption	10.5~14.5MHz LPF relay
D13	Relay surge absorption	14.5~21.5MHz LPF relay
D14	Relay surge absorption	21.5~30MHz LPF relay
D15	Relay surge absorption	Transmission/reception changeover relay
D16	Lightning surge protection	
D17,18	RF limiter	

### AT UNIT (X53-3340-00)

Ref. No.	Use/Function	Operation/Condition/Compatibility
Q1,2	Amplifier	Waveform shaping
Q3	Switching	On when APRE is "H"
Q4,5	Switching	Motor speed control pulse
IC1	DFF	Phase difference detection
IC2	Analog switch	For control changeover motor 1

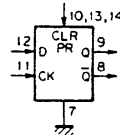

Function table

INPUTS		OUTPUTS	
CLOCK	D	Q	Q̄
↑	L	L	H
L	X	Q <sub>0</sub>	Q̄ <sub>0</sub>

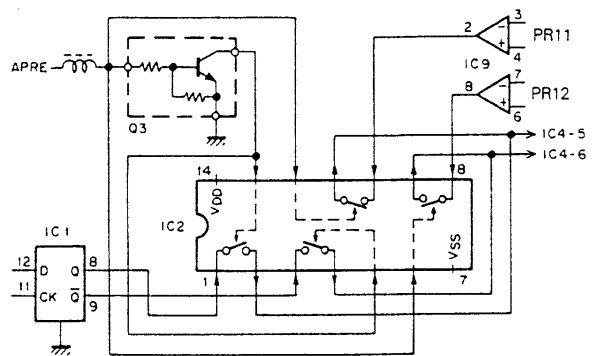

# TS-850S

## DESCRIPTION OF COMPONENTS

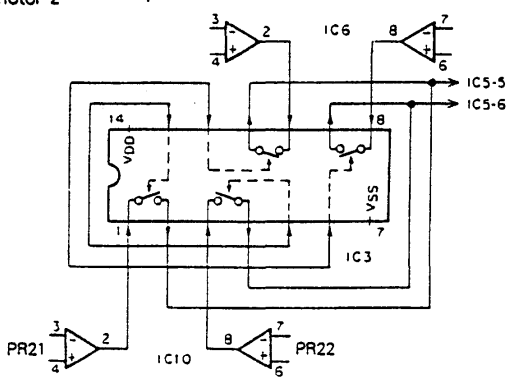
Ref. No.	Use/Function	Operation/Condition/Compatibility
IC3	Analog switch	For control changeover motor 2 
IC4	Motor drive	For motor 1
IC5	Motor drive	For motor 2
IC6	Comparator	Amplification difference detection
IC7	AVR	+5V
D1	Detection	Current component amplification detection
D2	Detection	Voltage component amplification detection
D3-8	Switching	Clipper
D10	Switching	Spike absorption
D101-103	Switching	Spike absorption
D105-108	Switching	Spike absorption
D109,110	Switching	Band information

Downloaded by   
  
 Amateur Radio Directory

## SEMICONDUCTOR DATA

Port : MB89363B (Digital unit IC1, 3)

Block diagram

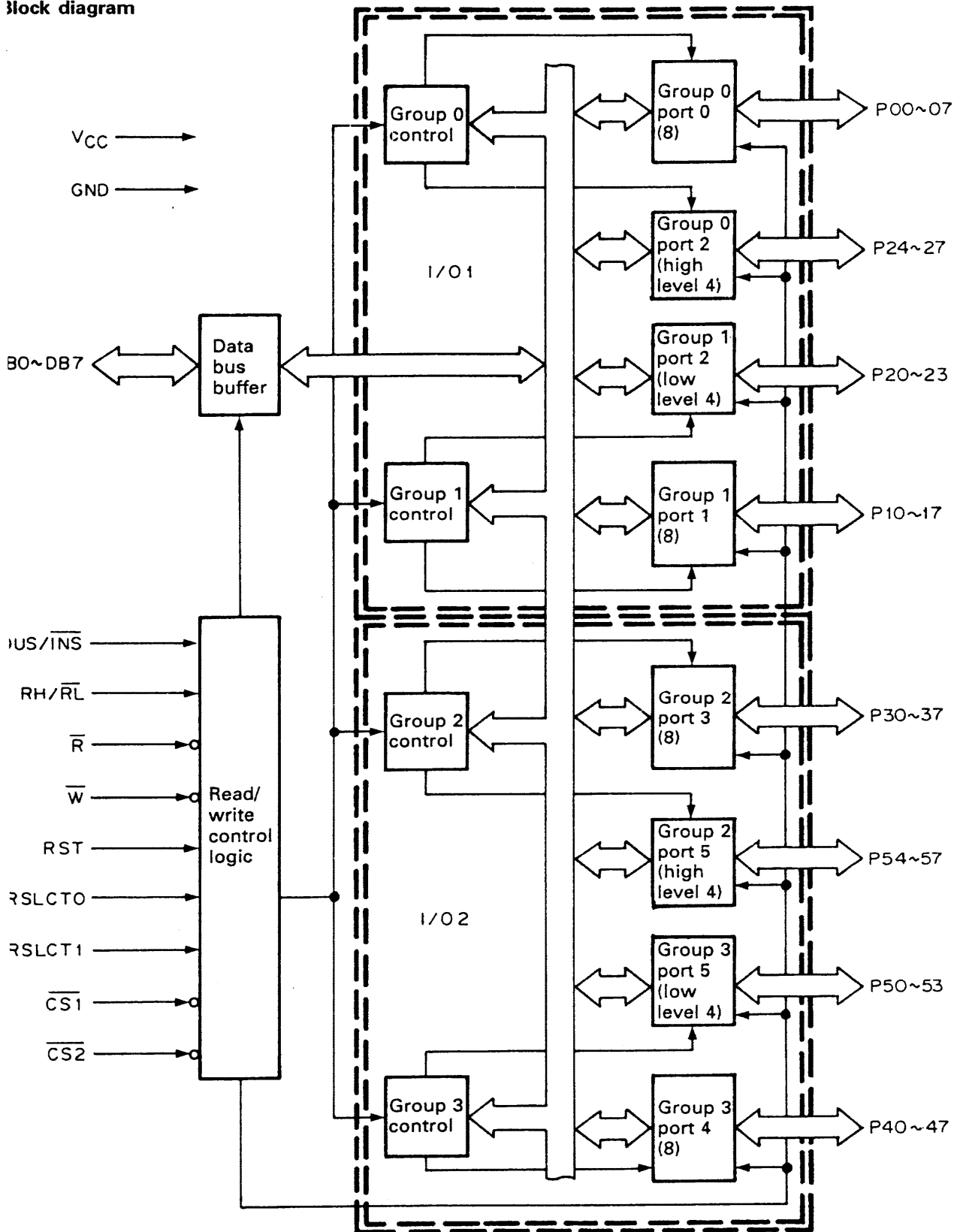

# TS-850S

## SEMICONDUCTOR DATA

### • Terminal function

Pin No.	Pin name	Name	I/O	Function
1-4 77-80	P30-P37	Port 3 all bits	I/O	Eight-bit general-purpose input/output port. These terminals are included in group 2. Three operation modes can be selected by setting the control parameter by software.
5	$\overline{W}$	Write	I	The control parameter and port output data item can be written using a low-level signal. The parameter and port data can be distinguished and selected using the $\overline{CS1}$ , $\overline{CS2}$ , $\overline{RSLCT0}$ , and $\overline{RSLCT1}$ signals.
6	RST	Initial setting reset	I	Input terminal. The MB89363B is set to the initial mode using a reset signal, and initial value 9B (hexadecimal) is automatically set for two control parameters. The initial mode indicates that all ports are in the input state of mode 0. All port terminals stay high in the initial mode. The active signal level is selected using an RH/RL signal. RH/RL = 0 : $\overline{RST}$ (active low)      RH/RL = 1 : RST (active high)
9	RH/RL	Reset active level selection	I	The RST terminal is set to active high or active low. RH/RL = 0 : $\overline{RST}$ (active low)      RH/RL = 1 : RST (active high) The RH/RL terminal is fixed at either Vcc or GND at all times.
11	$\overline{OUS/INS}$	Port 0 and 3 read value selection	I	This terminal indicates the output state of ports 0 and 3. It also selects whether the external terminal value of ports 0 and 3 is read directly or whether the output latch value of ports 0 and 3 is read directly when reading the value of ports 0 and 3. $\overline{OUS/INS} = 0$ : The output latch value of ports 0 and 3 is read. $\overline{OUS/INS} = 1$ : The external terminal value of ports 0 and 3 is read.
12-19	DB0-DB7	Bidirectional data bus	I/O	Eight-bit, bidirectional data bus. These terminals are used for data communication with the MPU. The bus signal making and breaking and data direction are controlled using the $\overline{CS1}$ , $\overline{CS2}$ , $\overline{R}$ and $\overline{W}$ signals.
20-23 25-28	P00-P07	Port 0 all bits	I/O	Eight-bit, general-purpose input/output port. These terminals are included in group 0. Three operation modes can be selected by setting the control parameter by software.
29 75	$\overline{CS1}$ $\overline{CS2}$	Device selection	I	When a low-level signal is input to this terminal, signals DB0 through DB7 are released and data communication with the MPU takes place. At that time, the control parameter is written, and data is written into or read from each port. $\overline{CS1} = 0$ : I/O1 $\overline{CS2} = 0$ : I/O2 Simultaneous selection of $\overline{CS1} = 0$ and $\overline{CS2} = 0$ is inhibited.
30, 74	GND	Ground terminal	I	0V.
31 32	$\overline{RSLCT0}$ $\overline{RSLCT1}$	Access selection	I	When data is sent to the MPU, the parameter and port are distinguished and selected using the $\overline{CS1}$ , $\overline{CS2}$ , $\overline{RSLCT0}$ , and $\overline{RSLCT1}$ signals.
34-40 43	P20-P27	Port 2 all bits	I/O	These terminals are used as a general-purpose input/output port, handshaking control terminals, and status data bit input/output terminals in accordance with the operation functions and modes of groups 0 and 1.
44-51	P10-P17	Port 1 all bits	I/O	Eight-bit, general-purpose input/output port. These terminals are included in group 1. Two operation modes can be selected by setting the control parameter by software.
53	Vcc			+5V power.
54-61	P40-P47	Port 4 all bits	I/O	Eight-bit, general-purpose input/output port. These terminals are included in group 3. Two operation modes can be selected by setting the control parameter by software.
62 65-71	P50-P57	Port 5 all bits	I/O	These terminals are used as a general-purpose input/output port, handshaking control terminals, and status data bit input/output terminals.
76	$\overline{R}$	Read	I	Data from each port is read using a low-level signal. The port type is selected using the $\overline{CS1}$ , $\overline{CS2}$ , $\overline{RSLCT0}$ , and $\overline{RSLCT1}$ signals.
7,8,10,24 33,41,42 52,63,64 72,73	NC	-	-	Connection to the NC terminal is inhibited.

## SEMICONDUCTOR DATA

### I/O Port : CXD1095Q (Digital unit IC2)

#### • Terminal connection

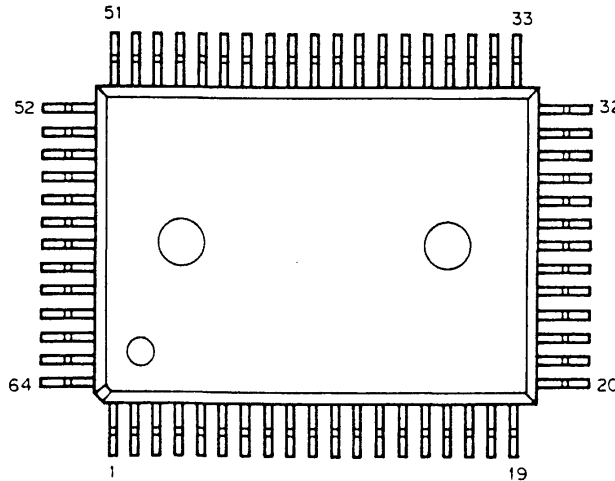

#### • Terminal function

Pin No.	Pin name	I/O	Function
1, 2	NC	-	Not connected.
3~9	PE1~PB7	I/O	Port B input/output terminals.
10	Vss	-	Connected to ground.
11~18	PC0~PC7	I/O	Port C input/output terminals.
19	NC	-	Not connected.
20~24	PD0~PD4	I/O	Port D input/output terminals.
25	Vss	-	Connected to ground.
26	Vdd	-	Connected to +5V.
27~29	PD5~PD7	I/O	Port D input/output terminals.
30~32	D0~D2	I/O	Eight bit, tristate, bidirectional data bus. Data can be sent by connecting these terminals to the data bus of a microcomputer system. Goes active when $\overline{CS} = 0$ and $\overline{RD} = 0$ or $\overline{WR} = 0$ .
33, 34	NC	-	Not connected.
35~39	D3~D7	I/O	Eight bit, tristate, bidirectional data bus. Data can be sent by connecting these terminals to the data bus of a microcomputer system. Goes active when $\overline{CS} = 0$ and $\overline{RD} = 0$ or $\overline{WR} = 0$ .
40	$\overline{CLR}$	I	The register output of port E (4-bit port) is cleared (becomes zero) when $\overline{CLR} = 0$ .
41	$\overline{ODEN}$	I	All ports enter the input state (high-impedance state) when $\overline{ODEN} = 0$ . No output data register or control register is set.
42	Vss	-	Connected to ground.
43	$\overline{WR}$	I	Data is written into CXD1095Q when $\overline{WR} = 0$ . Data bus information is written on the leading edge of the $\overline{WR}$ signal (0 to 1).
44	$\overline{RD}$	I	Data is read from CXD1095Q when $\overline{RD} = 0$ .
45	$\overline{CS}$	I	CXD1095Q is selected when $\overline{CS} = 0$ and enters the non-selection mode when $\overline{CS} = 1$ . Data lines D7 through D0 enter the high-impedance state.
46~48	A0~A2	I	Five ports and control registers are selected by addressing.
49, 50	PE0, PE1	I/O	Port E input/output terminals.
51	NC	-	Not connected.
52, 53	PE2, PE3	I/O	Port E input/output terminals.
54~56	PA0~PA2	I/O	Port A input/output terminals.
57	Vss	-	Connected to ground.
58	VDD	-	Connected to +5V.
59~63	PA3~PA7	I/O	Port A input/output terminals.
64	PB0	I/O	Port B input/output terminals.

Note : The  $\overline{CS}$ ,  $\overline{RD}$ ,  $\overline{WR}$ ,  $\overline{ODEN}$ , and  $\overline{CLR}$  signals are pulled up to Vcc in the IC.

# TS-850S

## SEMICONDUCTOR DATA

Block diagram

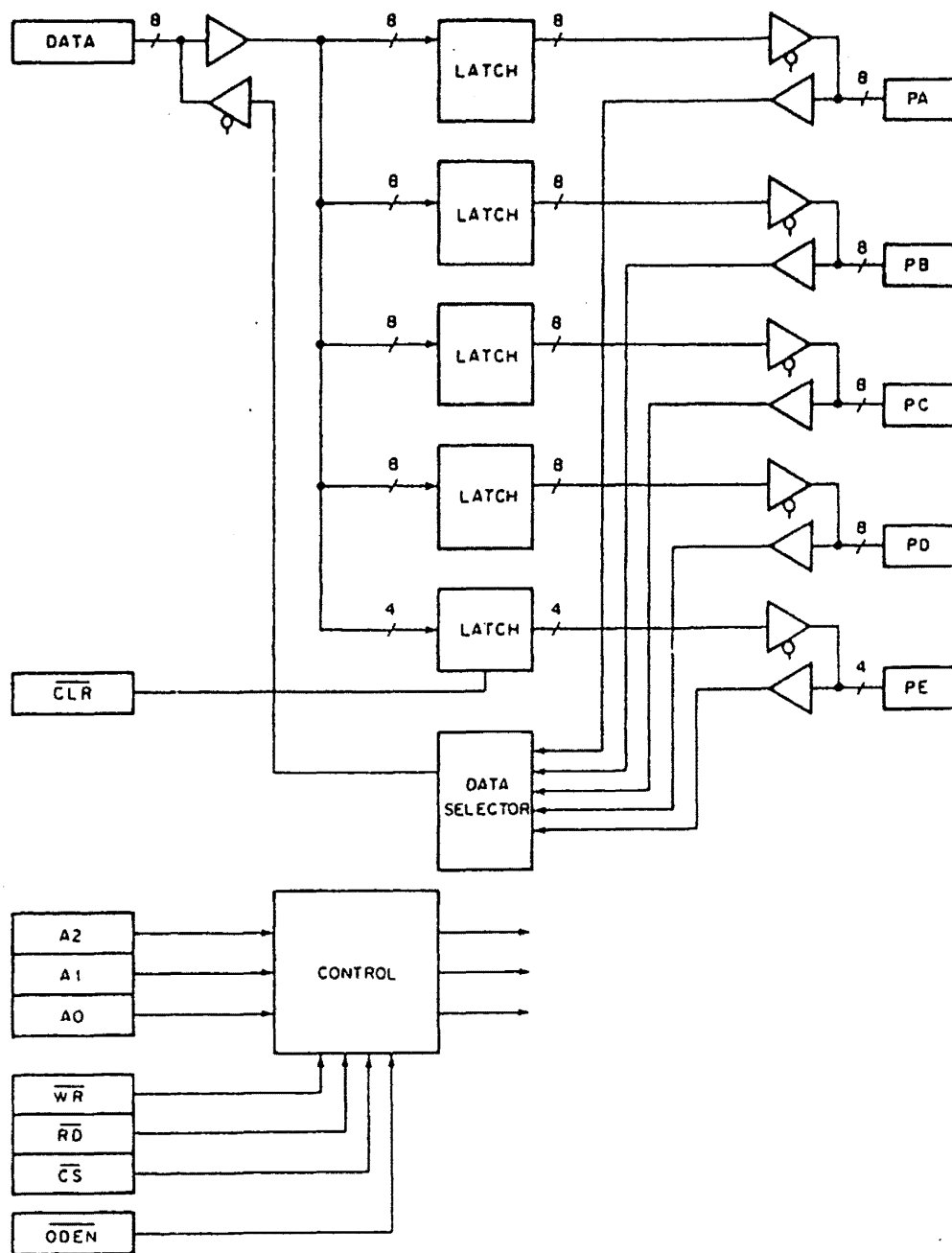



## SEMICONDUCTOR DATA

### A/D Converter : MB4052 (Digital unit IC5)

• Block diagram

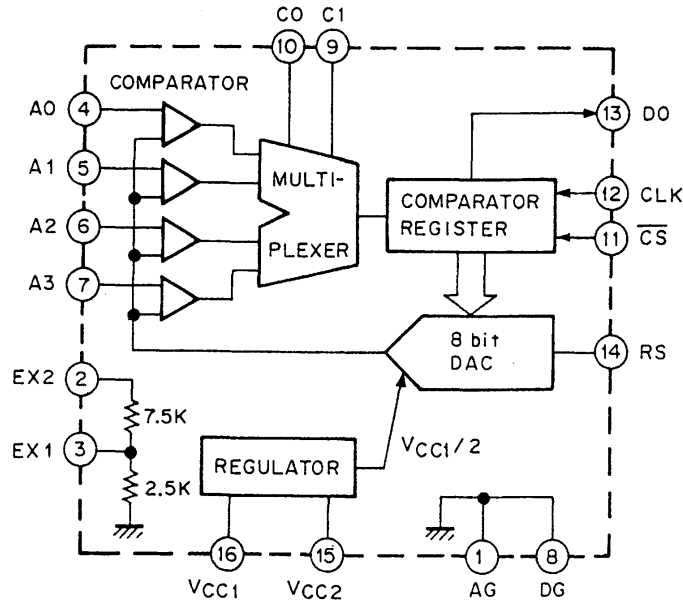

• Terminal function

Pin No.	Pin Name	Symbol	Function
2	Range expander input	EX2	Analog input pin for expanding the range.
3	Range expander output	EX1	Analog output pin for expanding the range. Connect to any pin from A0 to A3. By using EX1 and EX2, the range is expanded to the x4 range.
4-7	Analog entrance	A0-A3	4-ch analog input pin. Channel 1 is selected by channel select input C0 and C1.
9	Channel select input	C0	The input to designate the analog input channel for A/D converter.
10		C1	This signal is latched at the trailing edge of CS.
11	Chip select input	CS	This is the chip select input pin. When CS is inverted from "1" to "0", A/D converting starts and data output is enabled. After A/D converting is over or when an interrupt is required, set the CS back to "1".
12	A/D conversion clock	ADC CLK	This is the clock input pin for A/D conversion input to the comparator register sequentially. Conversion speed is determined by the clock speed. In the case of 8-bit, approx. 10 clocks will be needed. However, it is not necessary that the clock period be fixed.
13	Data output	DATA OUT	This is the open collector to output the result of A/D conversion. The data is output in the order of the start bit, most significant bit, 2nd significant bit, . . . least significant bit, and the stop bit, synchronized with ADC CLK.
14	Range select input	RS	This is the input pin for selecting the voltage range of analog input. The VFS = Vcc1/8 range is selected at "0", and the range of FVS = Vcc1/2 is selected at "1". During conversion, hold this pin to "0" or "1".
1	Analog ground	AG	Ground terminal.
8	Digital ground	DG	
15	Power supply pin 2	Vcc2	When driving with 3.5 to 6.0V of power, connect Vcc1 and Vcc2 to each other, and apply the power voltage to them.
16	Power supply pin 1	Vcc1	When driving 8 to 18V of power, apply the power voltage to Vcc2. At this time, the 5V stabilized voltage is output to Vcc1, and approx. 10mA current can be supplied externally to the IC. When either 3.5 to 6.0V or 8 to 18V power is used, Vcc1 is the reference voltage for A/D conversion.

• Channel select

C1	C0	Selected CH
0	0	A0
0	1	A1
1	0	A2
1	1	A3

• Range select

RS	Conversion voltage range
0	0 ~ Vcc1/8
1	0 ~ Vcc1/2

• Wiring example when expanding the range

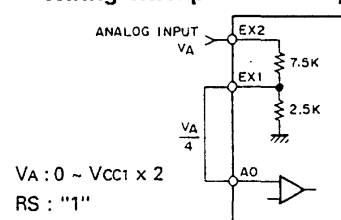

# TS-850S

## SEMICONDUCTOR DATA

CPU :  $\mu$ PD78C10G-36 (Digital unit IC6)

• Terminal connection

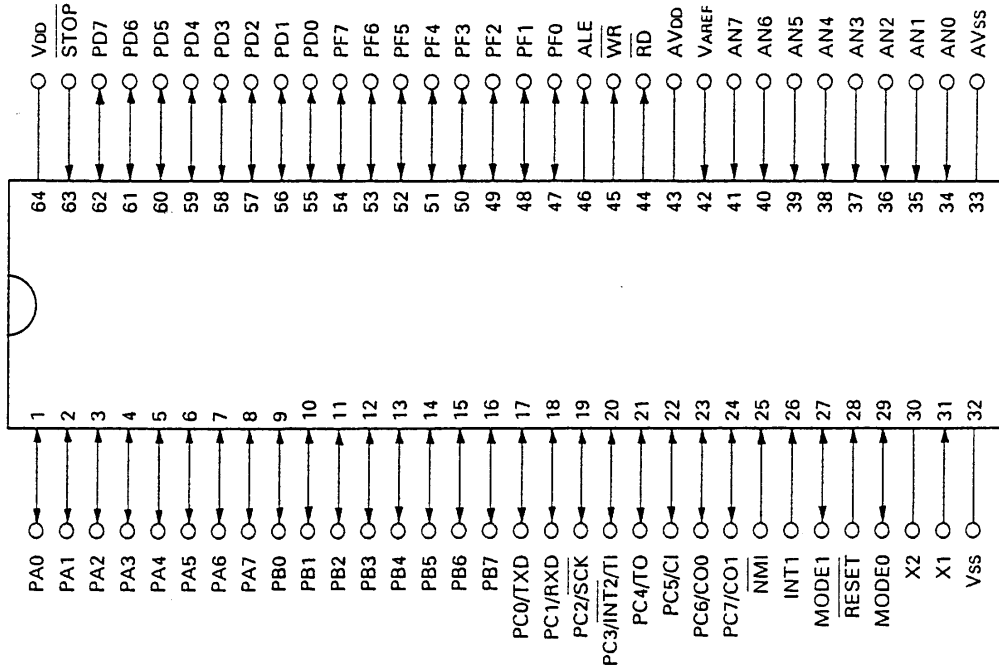

• Block diagram

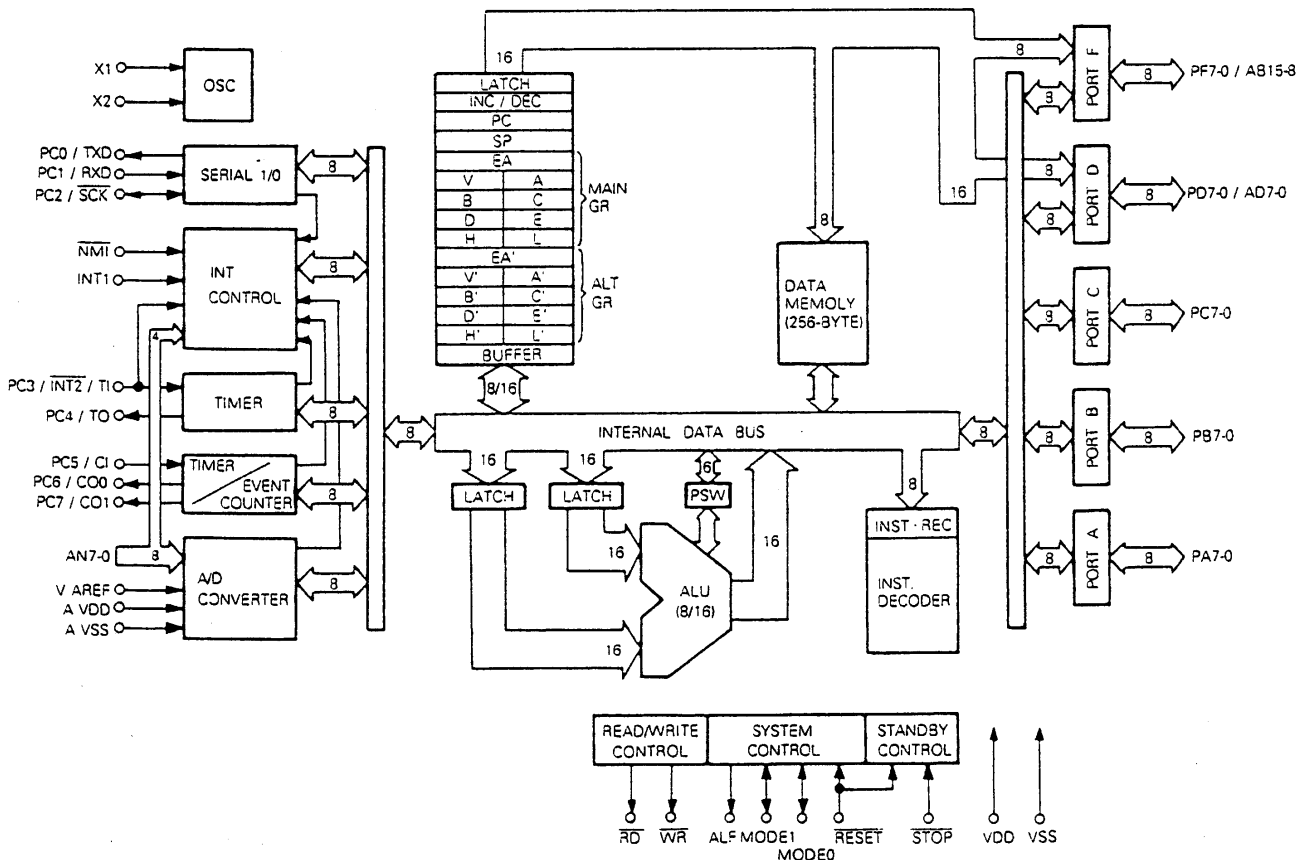

## SEMICONDUCTOR DATA

### • Terminal function

Pin No.	Pin Name	I/O	Functions												
1~8	PA7~PA0 (Port A)	I/O	8-bit input/output ports that allows designation of input and output in bit units.												
9~16	PB7~PB0 (Port B)	I/O	8-bit input/output ports that allows designation of input and output in bit units.												
17	PC0 (Port C)	I/O	8-bit input/output ports that allows designation of input and output in bit units.												
	TXD (Transmit data)	O	The output terminal for serial data.												
18	PC1 (Port C)	I/O	8-bit input/output ports that allows designation of input and output in bit units.												
	RXD (Receive data)	I	The input terminal for serial data.												
19	PC2 (Port C)	I/O	8-bit input/output ports that allows designation of input and output in bit units.												
	SCK (Serial clock)	I/O	The input/output terminal of the serial clock. The terminal functions as an output terminal when using the internal clock and as an input terminal when using an external clock.												
20	PC3 (Port C)	I/O	8-bit input/output ports that allows designation of input and output in bit units.												
	INT2 (Interrupt request)	I	The maskable interruption input terminal for the edge trigger (falling edge).												
	TI (Timer input)	I	This can also be used as a zero detection terminal of an AC input.												
21	PC4 (Port C)	I/O	8-bit input/output ports that allows designation of input and output in bit units.												
	TO (Timer output)	O	The square wave is output for the amount of the time counted on the timer taking a half cycle for 1 cycle of the internal clock.												
22	PC5 (Port C)	I/O	8-bit input/output ports that allows designation of input and output in bit units.												
	CI (Counter input)	I	The input terminal of external pulse for the timer/event counter.												
23,24	PC6, PC7 (Port C)	I/O	8-bit input/output ports that allows designation of input and output in bit units.												
	CO0,CO1 (Counter output 0, 1)	O	The output of the programmable rectangular wave in accordance with the timer/event count.												
25	NMI (Non-maskable interrupt)	I	The non-maskable interruption input terminal for the edge trigger (falling edge).												
26	INT1 (Interrupt request)	I	The maskable interruption input terminal for the edge trigger (rising edge). This can also be used as a zero cross detection terminal of an AC input.												
27,29	MODE0, MODE1 (Mode)	I/O	<p>The <math>\mu</math>PD78C10G is installed externally in accordance with the specifications of the MODE0, MODE1 terminal. Memory size of 4kB, 16kB or 64kB can be selected.</p> <table border="1" style="margin-left: auto; margin-right: auto;"> <thead> <tr> <th>MODE0</th> <th>MODE1</th> <th>External memory</th> </tr> </thead> <tbody> <tr> <td>0</td> <td>0</td> <td>4kB</td> </tr> <tr> <td>1</td> <td>0</td> <td>16kB</td> </tr> <tr> <td>1</td> <td>1</td> <td>64kB</td> </tr> </tbody> </table> <p>In addition, when the MODE0, MODE1 terminal is set to "1" (*1), a control signal is output in synchronization with ALE.</p>	MODE0	MODE1	External memory	0	0	4kB	1	0	16kB	1	1	64kB
MODE0	MODE1	External memory													
0	0	4kB													
1	0	16kB													
1	1	64kB													
28	RESET (Reset)	I	The system reset input of low level active.												
30,31	X1, X2 (Crystal)		The crystal connection terminal for oscillation of the system clock. This is input to X1 when a clock is supplied from outside.												
32	Vss		GND terminal.												
33	AVss (Analog Vss)		GND terminal of A/D converter.												
34~41	AN0~AN7 (Analog input)	I	The 8-bit analog input to the A/D converter. The AN7 to AN4 can be used as an edge detection (falling edge) input.												
42	VAREF (Reference voltage)	I	This serves as both the reference voltage input terminal of the A/D converter as well as control terminal of operation for the A/D converter.												
43	AVDD (Analog VDD)		The power terminal of the A/D converter.												
44	RD (Read strobe)	O	The output strobe signal for the reading operation of external memory. This is at the high level except for the read machine cycle of external memory. When the RESET signal is at the low level and during the hardware STOP mode, the output becomes a high impedance output.												
45	WR (Write strobe)	O	The output strobe signal for the writing operation of external memory. This is at the high level except for the write machine cycle of external memory. When the RESET signal is at the low level and during the hardware STOP mode, the output becomes a high impedance output.												
46	ALE (Address latch enable)	O	The PD7~PD0 pin output strobe signal for latch outside that output lower address data for the access external memory. When the RESET signal is at the low level and during the hardware STOP mode, the output becomes a high impedance output.												
47~54	PF7~PF0 (Port F)	I/O	8-bit input/output ports that allows designation of input and output in bit units.												
	AB15~AB8 (Address bus)	O	This serves as address data bus when using external memory.												
55~62	PD7~PD0 (Port D)	I/O													
	AD7~AD0 (Address/data bus)	I/O	This serves as multiplexed address/data bus when using external memory.												
63	STOP (Stop)	I	The control signal input terminal of the hardware STOP mode. When a low level signal is input, oscillation of the oscillator is discontinued.												
64	VDD		Positive power supply terminal.												

\*1 : The pull-up resistance R is  $4 \leq R \leq 0.4\text{tcyc}$  (K $\Omega$ ). tcyc is in ns units

# TS-850S

## SEMICONDUCTOR DATA

### RAM : TC5564APL-15 (Digital unit IC13)

#### • Block diagram

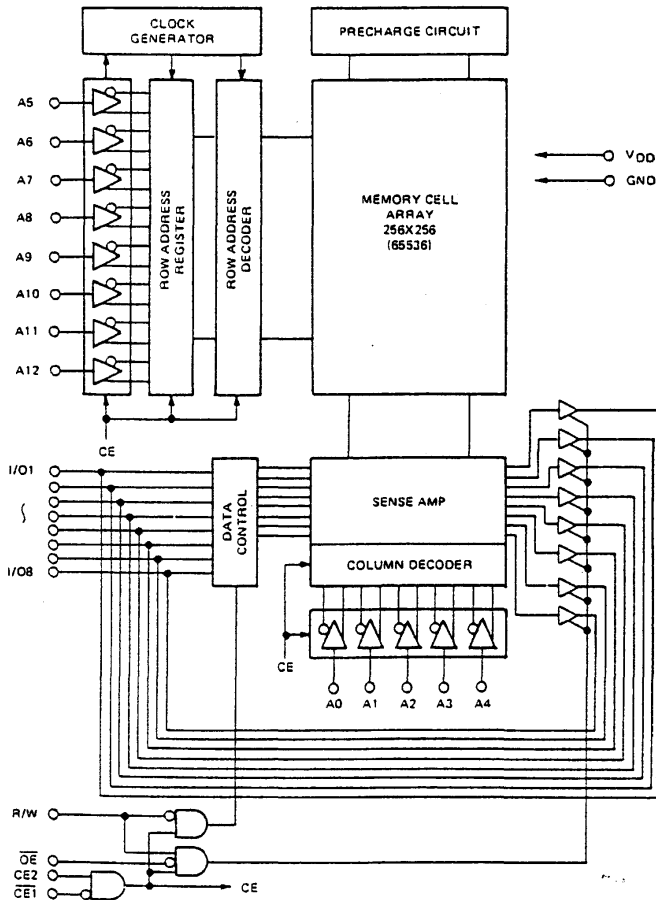

#### • Terminal connection

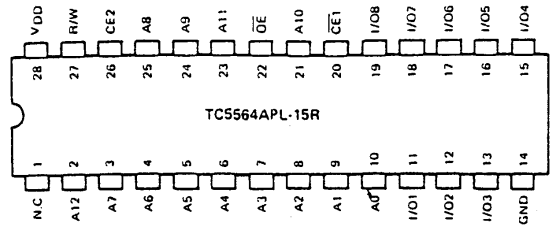

#### • Operation mode

Operation mode	CE1	CE2	OE	R/W	I/O1 ~ I/O8	Power
Read	L	H	L	H	D OUT	IDDO
Write	L	H	*	L	D IN	IDDO
Output disable	*	*	H	*	High-Z	IDDO
Standby	H	*	*	*	High-Z	IDDS
	*	L	*	*	High-Z	IDDS

#### • Description of terminals

Name	Description
A0 - A12	Address input
R/W	Read/write control input
OE	Output enable input
CE1, CE2	Chip enable input
I/O1 - I/O8	Data input/output
VDD	Power supply terminal (+5V)
GND	Ground
NC	Not used

#### • Access time (MAX)

Item	Time
Access time	150ns
CE1 access time	150ns
CE2 access time	150ns
OE access time	70ns

### Encoder Gate Array : LZ92K37 (Digital unit IC14)

#### • Terminal connection

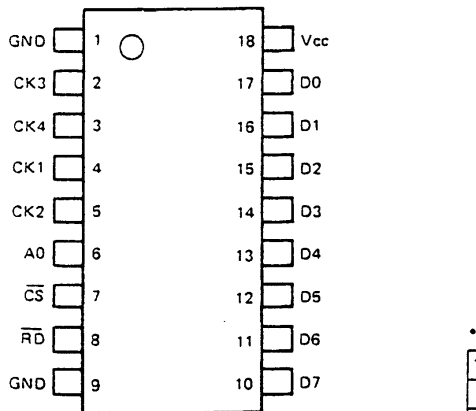

#### • Terminal function

Pin No.	I/O	Signal name	Pin No.	I/O	Signal name
1	-	GND	10	TO	D7
2	Icu	CK3	11	TO	D6
3	Icu	CK4	12	TO	D5
4	Icu	CK1	13	TO	D4
5	Icu	CK2	14	TO	D3
6	Ic	A0	15	TO	D2
7	Ic	CS	16	TO	D1
8	Ic	RD	17	TO	D0
9	-	GND	18	-	Vcc

Ic : C-MOS level input buffer  
 Icu : Input buffer with C-MOS level pull-up resistance  
 TO : Tristate output buffer

#### • Terminal function

Terminal name	Terminal function
CK1, 2	Rotary encoder pulse input
CK3, 4	Rotary encoder pulse input
A0	Output data selection input. 0 = CK1, 2 1 = CK3, 4
CS	Chip select input
RD	Read enable input
D0 ~ D7	Data bus output

# TS-850S

## PARTS LIST

※ New Parts

Parts without Parts No. are not supplied.

Les articles non mentionnés dans le Parts No. ne sont pas fournis.

Telle ohne Parts No. werden nicht geliefert.

TS-850S

Ref. No. 参照番号	Address 位置	New Parts 新	Parts No. 部品番号	Description 部品名 / 規格	Desti- nation 仕向	Re- marks 備考
<b>TS-850S</b>						
1	1B	*	A01-2014-01	METALLIC CABINET(TOP)		
2	3A	*	A01-2015-01	METALLIC CABINET(BOTTOM)		
3	2D	*	A22-0775-02	SUB PANEL		
4	3B	*	A40-0630-03	BOTTOM PLATE		
5	2D	*	A62-0043-03	PANEL		
7	2D	*	A62-0045-02	PANEL ASSY		
8	2G	*	A82-0002-02	REAR PANEL		
9	1C	*	B10-1159-03	FRONT GLASS		
10	2C		B11-0466-04	FILTER		
12	1E		B38-0350-15	LCD ASSY		
13	2B		B42-3343-04	LABEL(S/NØ)		
-	-		B44-2163-04	LABEL(UPC CØRD)		
16	1K	*	B46-0410-30	WARRANTY CARD	KK2	
16	1K	*	B46-0419-00	WARRANTY CARD	EE2E3	
16	1K	*	B46-0419-00	WARRANTY CARD	E4	
16	1K		B46-0422-00	WARRANTY CARD	PP2	
18	1K	*	B62-0061-00	INSTRUCTION MANUAL	KK2XX2	
18	1K	*	B62-0062-00	INSTRUCTION MANUAL	MM2M3	
18	1K	*	B62-0062-00	INSTRUCTION MANUAL	M4PP2	
18	1K	*	B62-0062-00	INSTRUCTION MANUAL	EE2E3	
18	1K	*	B62-0062-00	INSTRUCTION MANUAL	E4	
18	1K	*	B62-0063-00	INSTRUCTION MANUAL	EE2E3	
18	1K	*	B62-0063-00	INSTRUCTION MANUAL	E4	
18	1K	*	B62-0065-00	INSTRUCTION MANUAL		
20	2B	*	B72-0120-04	MODEL NAME PLATE(TS-850S)	KK2XX2	
20	2B	*	B72-0120-04	MODEL NAME PLATE(TS-850S)	PP2MM2	
20	2B	*	B72-0120-04	MODEL NAME PLATE(TS-850S)	M3M4	
20	2B	*	B72-0223-04	MODEL NAME PLATE(TS-850S)	EE2E3	
20	2B	*	B72-0223-04	MODEL NAME PLATE(TS-850S)	E4	
22	1A		D32-0416-04	STOPPER		
23	2G		E04-0167-05	RF COAXIAL CABLE RECEPTACLE		
24	1J		E07-0751-05	7P DIN PLUG ACSY		
25	1J		E07-1351-05	13P ROUND PLUG ACSY		
26	2G		E14-0107-05	PIN PLUG RTTY		
27	2G		E23-0616-14	GND TERMINAL ANT		
30	1J	*	E30-3035-05	DC CABLE		
31	1J		E31-2154-05	CONNECTING WIRE(CAL)		
-	-		E31-0081-05	CONNECTING WIRE(IF-RF)		
-	-		E31-6117-05	CONNECTING WIRE(FINAL/ANT)	K2M2M4	
-	-		E31-6117-05	CONNECTING WIRE(FINAL/ANT)	X2P2E2	
-	-		E31-6117-05	CONNECTING WIRE(FINAL/ANT)	E4	
-	-	*	E37-0060-05	CONNECTING WIRE(RF/PLL)		
-	-	*	E37-0061-15	CONNECTING WIRE(CAR/RF)		
-	-	*	E37-0062-05	CONNECTING WIRE(RF/PLL)		
-	-	*	E37-0063-15	CONNECTING WIRE(CAR/IF)		
-	-	*	E37-0064-05	CONNECTING WIRE(CAR/PLL)		
-	-	*	E37-0065-15	CONNECTING WIRE(CAR/PLL,ANT/RF)		
-	-	*	E37-0066-05	CONNECTING WIRE(RF/FINAL)		
-	-	*	E37-0067-05	CONNECTING WIRE(RF/IF)		
-	-	*	E37-0068-05	FLAT CABLE(IF/NB PROC AGC)		
-	-	*	E37-0069-05	FLAT CABLE(RF/RIT NOTC·VR)		

E: Scandinavia & Europe K: USA P: Canada W: Europe

U: PX(Far East, Hawaii) T: England M: Other Areas

UE: AAFES(Europe) X: Australia

△ indicates safety critical components.

# TS-850S

## PARTS LIST

× New Parts

Parts without Parts No. are not supplied.

Les articles non mentionnés dans le Parts No. ne sont pas fournis.

Teile ohne Parts No. werden nicht geliefert.

TS-850S

Ref. No. 参照番号	Address 位置	New Parts 新	Parts No. 部品番号	Description 部品名 / 規格	Desti- nation 仕 向	Re- marks 備考
-	-	*	E37-0070-05	FLAT CABLE(RF/SLOPE AF·VR)		
-	-	*	E37-0071-05	FLAT CABLE(IF/SEND VOX)		
-	-	*	E37-0072-05	FLAT CABLE(DIF/DISPLAY)		
-	-	*	E37-0073-05	FLAT CABLE(PLL/DDS)		
-	-	*	E37-0074-05	FLAT CABLE(FILTER/AVR)		
-	-	*	E37-0075-05	FLAT CABLE(DIG/RF X2)		
-	-	*	E37-0076-05	FLAT CABLE(DIG/PLL)		
-	-	*	E37-0077-05	FLAT CABLE(DIG/KEYBOARD)		
-	-	*	E37-0078-05	FLAT CABLE(DIG/TRANSIT)		
-	-	*	E37-0079-05	FLAT CABLE(DIG/IF)		
-	-	*	E37-0080-05	FLAT CABLE(RF/IF)		
-	-	*	E37-0081-05	CONNECTING WIRE(IF-RF)		
-	-	*	E37-0129-15	CONNECTING WIRE(MONI)		
-	-	*	E37-0130-05	CONNECTING WIRE(SPO)		
-	-	*	E37-0131-15	CONNECTING WIRE(10K)		
-	-	*	E37-0132-05	CONNECTING WIRE(AVR14S)		
-	-	*	E37-0133-15	CONNECTING WIRE(MOT)		
76	2A	*	E37-0134-15	CONNECTING WIRE(SP)		
-	-	*	E37-0135-05	CONNECTING WIRE(VS-2)		
78	1J		F06-3026-05	FUSE(3A) ACSY		
79	1A	*	F07-1327-04	COVER(UP SIDE CABINET)		
90	2G	*	F07-1329-04	COVER(ANT SW)		
MFAN	2F	*	F09-0423-15	FAN		
92	1G	*	F10-1467-03	SHIELDING PLATE(LPF)		
93	1G	*	F10-1468-03	SHIELDING PLATE(FINAL)		
94	1F	*	F10-1469-03	SHIELDING PLATE(PLL)		
95	2F	*	F10-1470-03	SHIELDING PLATE(DDS)		
96	3G	*	F10-1485-03	SHIELDING PLATE(RF)		
-	-	*	F51-0011-05	FUSE(25A)		
98	1J	*	F51-0011-05	FUSE(25A ACSY)		
99	2C		G02-0505-05	LEAF SPRING		
100	1G		G02-0574-04	SPRING		
101	2C		G09-0410-05	SPRING		
102	1A	*	G10-0697-04	NON-WOVEN FABRIC(SP)		
105	2D	*	G10-0702-04	NON-WOVEN FABRIC(SUB)		
106	1A	*	G10-0703-04	NON-WOVEN FABRIC(UP SIDE CAB.)		
107	1B	*	G10-0704-04	NON-WOVEN FABRIC		
108	1D	*	G10-0705-14	NON-WOVEN FABRIC		
109	1D	*	G10-0707-04	NON-WOVEN FABRIC(CHASSIS)		
-	-		G11-0609-04	CUSHION		
110	1D	*	G11-0657-14	CUSHION		
-	-	*	G11-0663-04	CUSHION(SUB)		
-	-		G13-0855-04	CUSHION		
113	2D	*	G13-0989-04	CUSHION(PANEL KNOB)		
114	2C	*	G13-0990-04	CUSHION(PANEL KNOB)		
115	1G	*	G13-1309-04	CUSHION(FINAL)		
116	1F	*	G13-1310-04	CUSHION(FAN)		
120	2A	*	G13-1311-04	CUSHION(CHASSIS)		
121	1A	*	G13-1312-04	CUSHION(SP)		
122	1D	*	G13-1313-04	CUSHION(LCD)		
123	2J		H13-0820-04	PROTECTION BOARD		
125	3K	*	H52-0076-04	ITEM CARTON BOX(AT)		KM1M3
125	3K	*	H52-0076-04	ITEM CARTON BOX(AT)		XPEE3
125	3K	*	H52-0077-04	ITEM CARTON BOX		K2M2M4

E: Scandinavia & Europe K: USA P: Canada W: Europe

U: PX(Far East, Hawaii) T: England M: Other Areas

UE: AAFES(Europe) X: Australia

△ indicates safety critical components.

## PARTS LIST

\* New Parts

Parts without Parts No. are not supplied.

Les articles non mentionnés dans le Parts No. ne sont pas fournis.

Teile ohne Parts No. werden nicht geliefert.

TS-850S

Ref. No. 参照番号	Address 位置	New Parts 新	Parts No. 部品番号	Description 部品名 / 規格	Desti- nation 仕向	Re- marks 備考
125	3K	*	H52-0077-04	ITEM CARTON BOX	X2P2E2 E4	
125	3K	*	H52-0077-04	ITEM CARTON BOX		
127	2J	*	H10-2708-01	POLYSTYRENE FOAMED FIXTURE(F)		
128	2K	*	H10-2709-01	POLYSTYRENE FOAMED FIXTURE(R)		
129	2K	*	H20-1437-03	PROTECTION COVER(TS-850S)		
130	1J		H25-0029-04	PROTECTION BAG(FUSE)		
132	1J		H25-0079-04	PROTECTION BAG(MIC)		
133	1J		H25-0112-04	PROTECTION BAG(DC CABLE)		
134	3B		J02-0049-14	FOOT(R)		
135	3A		J02-0423-04	FOOT(F)		
136	3A		J02-0424-04	FOOT(F)		
137	1A, 2B		J02-0441-05	FOOT(SIDE)		
-	-	*	J13-0414-05	FUSE HOLDER		
141	2A		J21-1144-34	MOUNTING HARDWARE(SP)		
142	2F	*	J21-4326-03	MOUNTING HARDWARE(FAN)		
143	1D		J31-0141-04	COLLAR(MIC)		
-	-		J61-0307-05	WIRE BAND		
146	2B	*	K01-0416-05	HANDLE		
147	2C	*	K21-0790-02	KNØB		
148	2C		K23-0794-04	KNØB (AGC)		
149	2C		K29-3109-14	KNØB		
150	1C		K29-3200-03	KNØB (BUTTON)		
152	1C		K29-4505-04	KNØB (BUTTON)	MIN	
153	1C		K29-4506-04	KNØB (BUTTON)	M-VFO	
154	1C		K29-4507-04	KNØB (BUTTON)	SCAN	
155	1C		K29-4508-04	KNØB (BUTTON)	DOWN	
156	1C		K29-4509-04	KNØB (BUTTON)	UP	
157	1D		K29-4512-04	KNØB		
158	1E		K29-4513-04	KNØB		
159	2C		K29-4515-04	KNØB		
160	2C		K29-4516-04	KNØB		
162	1C, 1E		K29-4518-04	KNØB		
163	2C	*	K29-4609-04	KNØB	M. CH	
164	2C	*	K29-4610-04	KNØB		
165	1C	*	K29-4611-03	KNØB (BUTTON)	1	
166	1C	*	K29-4612-03	KNØB (BUTTON)	2	
167	1C	*	K29-4613-03	KNØB (BUTTON)	3	
168	1C	*	K29-4614-03	KNØB (BUTTON)	4	
169	1C	*	K29-4615-03	KNØB (BUTTON)	5	
170	1C	*	K29-4616-03	KNØB (BUTTON)	6	
172	1C	*	K29-4617-03	KNØB (BUTTON)	7	
173	1C	*	K29-4618-03	KNØB (BUTTON)	8	
174	1C	*	K29-4619-03	KNØB (BUTTON)	9	
175	1C	*	K29-4620-03	KNØB (BUTTON)	0	
176	1C	*	K29-4621-03	KNØB (BUTTON)	CLR	
177	1C	*	K29-4622-03	KNØB (BUTTON)	ENT	
178	1C	*	K29-4623-03	KNØB (BUTTON)	METER	
179	1C	*	K29-4624-03	KNØB (BUTTON)	8.83	
180	1C	*	K29-4625-03	KNØB (BUTTON)	455	
182	1C	*	K29-4626-03	KNØB (BUTTON)	VØICE	
183	1C	*	K29-4627-03	KNØB (BUTTON)	M. IN	
184	1C	*	K29-4628-03	KNØB (BUTTON)	MR	
185	1C	*	K29-4629-03	KNØB (BUTTON)	1MHZ	
186	1C	*	K29-4630-03	KNØB (BUTTON)	F LOCK	

E: Scandinavia & Europe K: USA P: Canada W: Europe

U: PX(Far East, Hawaii) T: England M: Other Areas

UE: AAFES(Europe) X: Australia

 indicates safety critical components.

# TS-850S

## PARTS LIST

× New Parts

Parts without Parts No. are not supplied.

Les articles non mentionnés dans le Parts No. ne sont pas fournis.

Telle ohne Parts No. werden nicht geliefert.

TS-850S

SWITCH UNIT A (X41-3130-00)

Ref. No. 参照番号	Address 位置	New Parts 新	Parts No. 部品番号	Description 部品名 / 規格	Desti- nation 向	Re- marks 備考
187	1C	*	K29-4631-03	KNØB(BUTTON) TF-SET		
188	1C	*	K29-4632-03	KNØB(BUTTON) A=B		
189	1C	*	K29-4633-03	KNØB(BUTTON) LSB/USB		
190	1C	*	K29-4634-03	KNØB(BUTTON) CW/FSK		
192	1C	*	K29-4635-03	KNØB(BUTTON) FM/AM		
193	1D	*	K29-4636-04	KNØB POWER		
A	2G		N09-0372-04	SCREW(PULLEY) DC		
B	2G		N09-0682-04	HEX BOLT GND		
C	2G		N09-2051-05	SCREW DIGITAL X7	X1X2	
D	2G		N14-0115-05	NUT GND		
E	2G		N14-0509-05	NUT GND		
F	2G		N15-1040-46	FLAT WASHER GND		
G	2C		N19-0637-04	FLAT WASHER PANEL,MAIN KNØB		
H	1D, 1E		N32-2606-46	FLAT HEAD MACHINE SCREW(SW UNI		
I	2A, 3A		N32-3006-46	FLAT HEAD MACHINE SCREW(SUB PA		
J	1D	*	N32-3016-46	FLAT HEAD MACHINE SCREW(POWER		
K	1A, 3B		N33-3006-41	ØVAL HEAD MACHINE SCREW(CABINE		
L	2F, 3F		N87-2606-46	BRAZIER HEAD TAPTITE SCREW		
M	2G		N87-2608-46	BRAZIER HEAD TAPTITE SCREW		
N	1G, 3G		N87-3006-46	BRAZIER HEAD TAPTITE SCREW(AT,		
O	1F, 2G		N87-3008-46	BRAZIER HEAD TAPTITE SCREW(DDS		
P	3A, 3B		N87-4008-46	BRAZIER HEAD TAPTITE SCREW		
Q	1G		N88-2608-46	FLAT HEAD TAPTITE SCREW(FINAL		
R	2C		N90-3008-46	TP HEAD MACHINE SCREW(PANEL)		
195	1D		S40-2460-05	PUSH SWITCH(POWER)		
-	-		S50-1406-05	TACT SWITCH		
SP1	2A	*	T07-0276-05	SPEAKER		
198	1J		T91-0352-15	MICROPHONE		
205	1E		W02-0855-05	ENCODER		
206	1D, 2E	*	X41-3130-00	SWITCH UNIT A		
207	1E	*	X41-3140-00	SWITCH UNIT B(KEYBOARD)		
208	2F, 3G	*	X44-3120-00	RF UNIT(100W)		
209	1G	*	X45-1470-02	FINAL UNIT(100W)		
301	3F, 1G	*	X46-3080-11	DIGITAL UNIT		KK2PP2
301	3F, 1G	*	X46-3082-71	DIGITAL UNIT		EE2
301	3F, 1G	*	X46-3080-21	DIGITAL UNIT		MM2
301	3F, 1G	*	X46-3080-22	DIGITAL UNIT		M3M4
301	3F, 1G	*	X46-3080-71	DIGITAL UNIT		XX2
301	3F, 1G	*	X46-3082 72	DIGITAL UNIT		E3E4
302	1E, 3F	*	X48-3080-00	IF UNIT		
303	2F	*	X50-3130-00	PLL UNIT		
304	1F	*	X50-3140-00	CAR UNIT(DDS)		
305	1G, 2G	*	X51-3100-00	FILTER UNIT		
308	1I, 2I	*	X53-3340-00	AT UNIT		KMM3X
308	1I, 2I	*	X53-3340-00	AT UNIT		PEE3
<b>SWITCH UNIT A (X41-3130-00)</b>						
C1			CQ92M1H473K	MYLAR 0.047UF K		
CN1		*	E40-5478-05	PIN CONNECTOR(9P)		
CN2			E40-3299-05	PIN ASSY(2P)		
CN3			E40-0211-05	PIN CONNECTOR(2P)		
CN4		*	E40-5475-05	PIN CONNECTOR(5P)		
CN5			E40-3300-05	PIN ASSY(3P)		

E: Scandinavia & Europe K: USA P: Canada W: Europe

U: PX(Far East, Hawaii) T: England M: Other Areas

UE: AAFES(Europe) X: Australia

⚠ indicates safety critical components.



## PARTS LIST

× New Parts

Parts without Parts No. are not supplied.

Les articles non mentionnés dans le Parts No. ne sont pas fournis.

Teile ohne Parts No. werden nicht geliefert.

SWITCH UNIT A (X41-3130-00)

SWITCH UNIT B (X41-3140-00)

RF UNIT (X44-3120-00)

Ref. No. 参照番号	Address 位置	New Parts 新	Parts No. 部品番号	Description 部品名 / 規格	Desti- nation 仕向	Re- marks 備考
CN6		*	E40-5477-05	PIN CONNECTOR(8P)		
CN7		*	E40-5476-05	PIN CONNECTOR(7P)		
CN8 ,9			E40-3300-05	PIN CONNECTOR(3P)		
CN10			E40-3302-05	PIN CONNECTOR(5P)		
CN11		*	E40-5476-05	PIN CONNECTOR(7P)		
J1			E11-0437-05	PHONE JACK		
R1 -9			RK73FB2AXXXJ	CHIP R		
R10 -13			RK73EB2B221J	CHIP R 220 J 1/8W		
R14 -18			RK73FB2AXXXJ	CHIP R		
VR1		*	R24-3407-05	POTENTIOMETER NOTCH/SQ		
VR2		*	R19-9415-05	POTENTIOMETER NB.L/NB.WIDT		
VR3			R12-1085-05	TRIM POT. 2.2K		
VR4 ,5			R12-3126-05	TRIMMING POT.10K		
VR6		*	R24-3408-05	POTENTIOMETER (TONE/RIT)		
VR7		*	R19-3430-05	POTENTIOMETER (RF/AF GAI)		
VR8		*	R19-9414-05	POTENTIOMETER (KEY/CAR)		
VR9		*	R19-3431-05	POTENTIOMETER (SLOPE.TUN)		
VR10		*	R19-3432-05	POTENTIOMETER (MON/PROC)		
VR11		*	R24-9408-05	POTENTIOMETER (MIC/POWER)		
W1 -8			R92-0670-05	CHIP R 0 OHM		
W9			R92-0679-05	CHIP R 0 OHM		
W10 -17			R92-0670-05	CHIP R 0 OHM		
S1		*	S60-0401-05	ROTARY SWITCH(AGC.SW)		
S2		*	W02-1660-05	ENCODER(MEMORY&CHANNEL)		
<b>SWITCH UNIT B (X41-3140-00)</b>						
CN1			E40-5339-05	PIN CONNECTOR(25P)		
R1 -20			RK73FB2AXXXJ	CHIP R		
W1 -27			R92-0679-05	CHIP R 0 OHM		
S1 -25		*	S70-0403-05	TACT SWITCH(METER)		
S26 -28			S40-1429-05	TACT SWITCH		
S29 -31		*	S70-0403-05	TACT SWITCH(METER)		
S32 -34			S40-1429-05	PUSH SWITCH		
S35 ,36		*	S70-0403-05	TACT SWITCH(METER)		
D1 -7			RLS73	DIODE		
D8		*	B30-2006-05	LED(AT)		
D9 -11		*	B30-2007-05	LED(AIP)		
D12		*	B30-2005-05	LED(TX)		
Q1 -6			DTA143EK	DIGITAL TRANSISTOR		
Q7 -9			DTC143EK	DIGITAL TRANSISTOR		
<b>RF UNIT (X44-3120-00)</b>						
C1 ,2			CK73FB1E103K	CHIP C 0.01UF K		
C3 -7			CC73FCH1HXXXJ	CHIP C		
C8 ,9			CK73FF1E104Z	CHIP C 0.1UF Z		
C10			CK73EF1C105Z	CHIP C 1.0UF Z		
C11 ,12			CK73FF1E104Z	CHIP C 0.1UF Z		
C13			CK73EF1C105Z	CHIP C 1.0UF Z		
C14 -16			CK73FB1EXXXX	CHIP C		
C17 -19			CK73FB1HXXXX	CHIP C		
C20			CK73FF1E104Z	CHIP C 0.1UF Z		
C21			CK73EF1C105Z	CHIP C 1.0UF Z		

E: Scandinavia & Europe K: USA P: Canada W: Europe

U: PX(Far East, Hawaii) T: England M: Other Areas

UE: AAFES(Europe) X: Australia

 indicates safety critical components.

# TS-850S

## PARTS LIST

× New Parts

Parts without Parts No. are not supplied.

Les articles non mentionnés dans le Parts No. ne sont pas fournis.

Telle ohne Parts No. werden nicht geliefert.

RF UNIT (X44-3120-00)

Ref. No. 参照番号	Address 位置	New Parts 新	Parts No. 部品番号	Description 部品名 / 規格	Desti- nation 仕向	Re- marks 備考
C23	-25		CK73FB1HXXXX	CHIP C		
C26			CK73FF1E104Z	CHIP C	0.1UF	Z
C27	, 28		CK73FB1H102K	CHIP C	1000PF	K
C29			CK73FF1E104Z	CHIP C	0.1UF	Z
C30			CK73FB1H222K	CHIP C	2200PF	K
C31			CC73FSL1H561J	CHIP C	650PF	J
C32			CK73FB1H222K	CHIP C	2200PF	K
C33			CK73FF1E104Z	CHIP C	0.1UF	Z
C34	, 35		CK73FB1H102K	CHIP C	1000PF	K
C36			CK73FF1E104Z	CHIP C	0.1UF	Z
C37			CK73FB1H102K	CHIP C	1000PF	K
C38			CC73FSL1H271J	CHIP C	270PF	J
C39			CK73FB1H102K	CHIP C	1000PF	K
C40			CK73FF1E104Z	CHIP C	0.1UF	Z
C41	, 42		CK73FB1H102K	CHIP C	1000PF	K
C43			CK73FF1E104Z	CHIP C	0.1UF	Z
C44	, 45		CC73FCH1H1000	CHIP C	10PF	0
C46			CK73FF1E104Z	CHIP C	0.1UF	Z
C47	, 48		CK73FB1H102K	CHIP C	1000PF	K
C49			CK73FF1E104Z	CHIP C	0.1UF	Z
C50			CK73FB1H102K	CHIP C	1000PF	K
C51			CC73FSL1H121J	CHIP C	120PF	J
C52			CK73FB1H102K	CHIP C	1000PF	K
C53			CK73FF1E104Z	CHIP C	0.1UF	Z
C54	, 55		CK73FB1H102K	CHIP C	1000PF	K
C56			CK73FF1E104Z	CHIP C	0.1UF	Z
C57			CK73FB1H102K	CHIP C	1000PF	K
C58			CC73FCH1H820J	CHIP C	82PF	J
C59			CK73FB1H102K	CHIP C	1000PF	K
C60			CK73FF1E104Z	CHIP C	0.1UF	Z
C61	, 62		CK73FB1H102K	CHIP C	1000PF	K
C63			CK73FF1E104Z	CHIP C	0.1UF	Z
C64	, 65		CC73FCH1H040C	CHIP C	4PF	C
C66			CK73FF1E104Z	CHIP C	0.1UF	Z
C67	-68		CK73FB1HXXXX	CHIP C		
C69			CK73FF1E104Z	CHIP C	0.1UF	Z
C70			CC73FSL1H391J	CHIP C	390PF	J
C71			CC73FCH1H680J	CHIP C	68PF	J
C72			CC73FSL1H151J	CHIP C	150PF	J
C73			CK73FF1E104Z	CHIP C	0.1UF	Z
C74	, 75		CK73FB1H102K	CHIP C	1000PF	K
C76			CK73FF1E104Z	CHIP C	0.1UF	Z
C77	, 78		CC73FCH1H050C	CHIP C	5PF	C
C79			CK73FF1E104Z	CHIP C	0.1UF	Z
C80	, 81		CK73FB1H102K	CHIP C	1000PF	K
C82			CK73FF1E104Z	CHIP C	0.1UF	Z
C83	-84		CC73FCH1HXXXXJ	CHIP C		
C86			CK73FF1E104Z	CHIP C	0.1UF	Z
C87	, 88		CK73FB1H102K	CHIP C	1000PF	K
C89			CK73FF1E104Z	CHIP C	0.1UF	Z
C90	-92		CK73FB1HXXXX	CHIP C		
C93	, 94		CK73FF1E104Z	CHIP C	0.1UF	Z
C95			CC73FSL1H121J	CHIP C	120PF	J
C96	-99		CK73FB1E103K	CHIP C	0.01UF	K
C100			CC73FCH1H390J	CHIP C	39PF	J

E: Scandinavia & Europe K: USA P: Canada W: Europe

U: PX(Far East, Hawaii) T: England M: Other Areas

UE: AAFES(Europe) X: Australia

△ indicates safety critical components.

## PARTS LIST

× New Parts

Parts without Parts No. are not supplied.

Les articles non mentionnés dans le Parts No. ne sont pas fournis.

Teile ohne Parts No. werden nicht geliefert.

RF UNIT (X44-3120-00)

Ref. No. 参照番号	Address 位置	New Parts 新	Parts No. 部品番号	Description 部品名 / 規格	Desti- nation 仕向	Re- marks 備考
C101, 102			CK73FB1E103K	CHIP C 0.01UF K		
C103			CK73FF1E104Z	CHIP C 0.1UF Z		
C104			CK73FB1E103K	CHIP C 0.01UF K		
C105			CK73EF1C105Z	CHIP C 1.0UF Z		
C106-109			CK73FF1EXXXZ	CHIP C		
C110			CK73EF1C105Z	CHIP C 1.0UF Z		
C111-113			CK73FF1E104Z	CHIP C 0.1UF Z		
C114-115			CC73FCH1HXXXJ	CHIP C		
C116			CC73FSL1H221J	CHIP C 220PF J		
C117-118			CC73FCH1HXXXJ	CHIP C		
C119-121			CK73FF1E104Z	CHIP C 0.1UF Z		
C122			CC73FCH1H220J	CHIP C 22PF J		
C123			CK73FB1E103K	CHIP C 0.01UF K		
C124			CK73FF1E104Z	CHIP C 0.1UF Z		
C125			CE04EW1C470M	ELECTRØ 47UF 16WV		
C126			CK73FB1E103K	CHIP C 0.01UF K		
C127			CC73FCH1H020C	CHIP C 2.0PF C		
C128			CK73FF1E104Z	CHIP C 0.1UF Z		
C129			CC73FSL1H471J	CHIP C 47PF J		
C130			CK73FB1E103K	CHIP C 0.01UF K		
C131-135			CC73FCH1HXXXC	CHIP C		
C136			CK73EB1E104K	CHIP C 0.10UF K		
C137, 138			CK73FB1E103K	CHIP C 0.01UF K		
C139			CC73FCH1H010C	CHIP C 1PF C		
C141			CK73FB1H102K	CHIP C 1000PF K		
C142-144			CK73FB1E103K	CHIP C 0.01UF K		
C145			CC73FSL1H221J	CHIP C 220PF J		
C146-147			CC73FCH1HXXXJ	CHIP C		
C148-149			CK73FB1EXXXK	CHIP C		
C150			CC73FCH1H330J	CHIP C 33PF J		
C151			CK73FB1E103K	CHIP C 0.01UF K		
C152			CC73FCH1H100D	CHIP C 10PF D		
C153, 154			CK73FB1E103K	CHIP C 0.01UF K		
C155			CC73FCH1H220J	CHIP C 22PF J		
C156			CK73FB1E103K	CHIP C 0.01UF K		
C157, 158			CC73FCH1H470J	CHIP C 47PF J		
C159			CE04EW1C100M	ELECTRØ 10UF 16WV		
C160, 161			CK73FB1E103K	CHIP C 0.01UF K		
C162			CC73FSL1H121J	CHIP C 120PF J		
C163-170			CK73FB1E103K	CHIP C 0.01UF K		
C171			CC73FCH1H150J	CHIP C 15PF J		
C172-175			CK73FB1E103K	CHIP C 0.01UF K		
C176			CC73FCH1H020C	CHIP C 2.0PF C		
C178-181			CK73FB1E103K	CHIP C 0.01UF K		
C182			CC73FCH1H010C	CHIP C 1PF C		
C183			CK73FF1E104Z	CHIP C 0.1UF Z		
C184-188			CK73FB1E103K	CHIP C 0.01UF K		
C189			CC73FCH1H010C	CHIP C 1PF C		
C190-193			CK73FB1E103K	CHIP C 0.01UF K		
C194			CE04EW1H010M	ELECTRØ 1.0UF 50WV		
C195			CK73FB1E103K	CHIP C 0.01UF K		
C196			CE04EW1C100M	ELECTRØ 10UF 16WV		
C197-202			CK73FB1E103K	CHIP C 0.01UF K		
C203			CK73EF1E474Z	CHIP C 0.47UF Z		
C204-206			CK73FB1E103K	CHIP C 0.01UF K		

E: Scandinavia & Europe K: USA P: Canada W: Europe

U: PX(Far East, Hawaii) T: England M: Other Areas

UE: AAFES(Europe) X: Australia

⚠ indicates safety critical components.

# TS-850S

## PARTS LIST

× New Parts

Parts without Parts No. are not supplied.

Les articles non mentionnés dans le Parts No. ne sont pas fournis.

Telle ohne Parts No. werden nicht geliefert.

RF UNIT (X44-3120-00)

Ref. No. 参照番号	Address 位置	New Parts 新	Parts No. 部品番号	Description 部品名 / 規格	Desti- nation 仕向	Re- marks 備考
C207-209			CC73FCH1HXXXC	CHIP C		
C210			CC73FSL1H471J	CHIP C	47PF	J
C211			CK73FB1E103K	CHIP C	0.01UF	K
C212			CC73FSL1H471J	CHIP C	47PF	J
C213-216			CK73FB1E103K	CHIP C	0.01UF	K
C217, 218			CC73FSL1H471J	CHIP C	47PF	J
C219, 220			CK73FB1E103K	CHIP C	0.01UF	K
C221			CK73FB1H102K	CHIP C	1000PF	K
C222			CK73FB1E103K	CHIP C	0.01UF	K
C223			CC73FSL1H471J	CHIP C	47PF	J
C224, 225			CK73FB1E103K	CHIP C	0.01UF	K
C226			CC73FCH1H470J	CHIP C	47PF	J
C227			CK73FB1E103K	CHIP C	0.01UF	K
C228-229			CC73FCH1HXXXJ	CHIP C		
C230			CK73FF1E104Z	CHIP C	0.1UF	Z
C231			CK73FB1H102K	CHIP C	1000PF	K
C232			CC73FSL1H271J	CHIP C	270PF	J
C233			CE04EW1C100M	ELECTRØ	10UF	16WV
C234, 235			CK73FF1E104Z	CHIP C	0.1UF	Z
C237			CC73FCH1H101J	CHIP C	100PF	J
C238			CK73FB1E103K	CHIP C	0.01UF	K
C239			CK73FF1E104Z	CHIP C	0.1UF	Z
C240			CK73FB1E103K	CHIP C	0.01UF	K
C242-246			CK73FF1E104Z	CHIP C	0.1UF	Z
C247			CE04EW1C100M	ELECTRØ	10UF	16WV
C248-249			CK73EB1EXXXK	CHIP C		
C250			CK73FF1E104Z	CHIP C	0.1UF	Z
C252			CK73FB1E223K	CHIP C	0.022UF	K
C253			CK73EB1E473K	CHIP C	0.047UF	K
C254			CE04EW1C220M	ELECTRØ	22UF	16WV
C255			CE04EW1C100M	ELECTRØ	10UF	16WV
C257			CK73FB1E103K	CHIP C	0.01UF	K
C258			CC73FCH1H101J	CHIP C	100PF	J
C259			CE04EW1C100M	ELECTRØ	10UF	16WV
C260, 261			CK73FB1E103K	CHIP C	0.01UF	K
C263			CE04EW1C100M	ELECTRØ	10UF	16WV
C264, 265			CK73FF1E104Z	CHIP C	0.1UF	Z
C266			CK73EF1C105Z	CHIP C	1.0UF	Z
C267-269			CK73FB1EXXXK	CHIP C		
C270, 271			CK73FB1H102K	CHIP C	1000PF	K
C275-278			CK73FB1E103K	CHIP C	0.01UF	K
C279, 280			CK73FF1E104Z	CHIP C	0.1UF	Z
C281			CC73FSL1H221J	CHIP C	220PF	J
C282			CK45B2H102K	CERAMIC	1000PF	K
C283			CK73FB1E103K	CHIP C	0.01UF	K
C285-288			CC73FCH1HXXXJ	CHIP C		
C289			CK73FB1E103K	CHIP C	0.01UF	K
C290			CK73FF1E104Z	CHIP C	0.1UF	Z
C291			CC73FCH1H050C	CHIP C	5PF	C
C292-298			CK73FB1EXXXK	CHIP C		
C300			CK73FF1E104Z	CHIP C	0.1UF	Z
C301-302			CK73FB1EXXXK	CHIP C		
C303			CK73FF1E104Z	CHIP C	0.1UF	Z
C304-603			CK73FB1EXXXK	CHIP C		
C604			CE04EW1C100M	ELECTRØ	10UF	16WV

E: Scandinavia & Europe K: USA P: Canada W: Europe

U: PX(Far East, Hawaii) T: England M: Other Areas

UE: AAFES(Europe) X: Australia

△ indicates safety critical components.

## PARTS LIST

× New Parts

Parts without Parts No. are not supplied.

Les articles non mentionnés dans le Parts No. ne sont pas fournis.

Telle ohne Parts No. werden nicht geliefert.

RF UNIT (X44-3120-00)

Ref. No. 参照番号	Address 位置	New Parts 新	Parts No. 部品番号	Description 部品名 / 規格	Desti- nation 仕向	Re- marks 備考
C605			CK73FB1E103K	CHIP C 0.01UF K		
C607			CE04EW1H010M	ELECTRØ 1.0UF 50WV		
C608-612			CK73FB1E103K	CHIP C 0.01UF K		
C615			CK73FB1H102K	CHIP C 1000PF K		
C616			CC73FSL1H331J	CHIP C 330PF J		
C617-619			CK73FB1E103K	CHIP C 0.01UF K		
C620, 621			CE04EW1H010M	ELECTRØ 1.0UF 50WV		
C622			CE04EW1C100M	ELECTRØ 10UF 16WV		
C623			CK73EB1E104K	CHIP C 0.10UF K		
C624-626			CE04EW1C330M	ELECTRØ 33UF 16WV		
C627			CK73FB1E103K	CHIP C 0.01UF K		
C628			CE04EW1C330M	ELECTRØ 33UF 16WV		
C629			CK73EF1C10SZ	CHIP C 1.0UF Z		
C630			CE04EW1H010M	ELECTRØ 1.0UF 50WV		
C631			CE04EW1A101M	ELECTRØ 100UF 10WV		
C632			CK73FB1E123K	CHIP C 0.012UF K		
C633, 634			CE04EW1A101M	ELECTRØ 100UF 10WV		
C635			CE04EW1C100M	ELECTRØ 10UF 16WV		
C636			CK73FB1E103K	CHIP C 0.01UF K		
C637			CE04EW1H010M	ELECTRØ 1.0UF 50WV		
TC1			C05-0344-05	TRIMMING CAP 30PF		
CN1 -6			E04-0154-05	RF COAXIAL CABLE RECEPTACLE		
CN7			E13-0166-05	PIN JACK		
CN8			E40-3240-05	PIN CONNECTOR(5P)		
CN9		*	E40-5470-05	PIN CONNECTOR(13P)		
CN10		*	E40-5502-05	PIN CONNECTOR(21P)		
CN11		*	E40-5474-05	PIN CONNECTOR(30P)		
CN12			E40-3237-05	PIN CONNECTOR(2P)		
CN13			E40-3242-05	PIN CONNECTOR(7P)		
CN14, 15		*	E40-5471-05	PIN CONNECTOR(18P)		
CN16			E40-5066-05	PIN CONNECTOR(9P)		
CN17			E40-3237-05	PIN CONNECTOR(2P)		
CN18, 19			E04-0154-05	RF COAXIAL CABLE RECEPTACLE		
CN20			E06-0752-05	CYLINDRICAL RECEPTACLE		
CN21-24			E40-5059-05	PIN CONNECTOR		
CN25-29			E04-0154-05	RF COAXIAL CABLE RECEPTACLE		
CN401			J13-0071-05	FUSE HOLDER		
CN501			E40-5182-05	PIN ASSY(5P)		
CN502			E40-5187-05	PIN ASSY(10P)		
CN503			E40-5185-05	PIN ASSY(8P)		
CN504		*	E40-5480-05	PIN CONNECTOR(26P)		
CN505			E40-3240-05	PIN CONNECTOR(5P)		
CN506			E40-3243-05	PIN CONNECTOR(8P)		
CN507			E40-3237-05	PIN CONNECTOR(2P)		
CN508		*	E40-5488-05	PIN CONNECTOR(2P)		
CN601			E40-3240-05	PIN CONNECTOR(5P)		
CN602		*	E40-5466-05	PIN CONNECTOR(5P)		
CN603			E40-5066-05	PIN CONNECTOR(9P)		
TP3			E23-0465-05	TERMINAL		
TP6			E23-0465-05	TERMINAL		
TP600			E23-0465-05	TERMINAL		
W1		*	E37-0113-05	CONNECTING WIRE		
W2		*	E37-0114-05	CONNECTING WIRE		
W401		*	E37-0115-15	CONNECTING WIRE		

E: Scandinavia & Europe K: USA P: Canada W: Europe

U: PX(Far East, Hawaii) T: England M: Other Areas

UE: AAFES(Europe) X: Australia

 indicates safety critical components.

# TS-850S

## PARTS LIST

× New Parts

Parts without Parts No. are not supplied.

Les articles non mentionnés dans le Parts No. ne sont pas fournis.

Telle ohne Parts No. werden nicht geliefert.

RF UNIT (X44-3120-00)

Ref. No. 参照番号	Address 位置	New Parts 新	Parts No. 部品番号	Description 部品名 / 規格	Desti- nation 仕 向	Re- marks 備考
W402 W501,502		*	E37-0112-05 R92-0150-05	CONNECTING WIRE CHIP R 0 OHM		
F401		*	F06-3026-15 J32-0761-04	FUSE(3A) STUD(PCB)		
L1 ,2		*	L40-4701-15	SMALL FIXED INDUCTOR(47UH)		
L3			L40-2782-14	SMALL FIXED INDUCTOR(.27UH)		
L4			L40-2282-14	SMALL FIXED INDUCTOR(.22UH)		
L5			L40-1021-15	SMALL FIXED INDUCTOR(1UH)		
L6 ,7		*	L40-1501-15	SMALL FIXED INDUCTOR(15UH)		
L8 ,9		*	L40-5691-15	SMALL FIXED INDUCTOR(5.6UH)		
L10			L40-1592-15	SMALL FIXED INDUCTOR(1.5UH)		
L11		*	L40-8291-15	SMALL FIXED INDUCTOR(8.2UH)		
L12			L40-1592-15	SMALL FIXED INDUCTOR(1.5UH)		
L13		*	L40-1292-15	SMALL FIXED INDUCTOR(1.2UH)		
L14		*	L40-5691-15	SMALL FIXED INDUCTOR(5.6UH)		
L15		*	L40-1292-15	SMALL FIXED INDUCTOR(1.2UH)		
L16			L40-1092-15	SMALL FIXED INDUCTOR(1UH)		
L17		*	L40-3391-15	SMALL FIXED INDUCTOR(3.3UH)		
L18			L40-1092-15	SMALL FIXED INDUCTOR(1UH)		
L19 -21		*	L34-4262-05	COIL		
L22		*	L40-3382-15	SMALL FIXED INDUCTOR(.33UH)		
L23		*	L40-2792-15	SMALL FIXED INDUCTOR(2.7UH)		
L24		*	L40-3382-15	SMALL FIXED INDUCTOR(.33UH)		
L25		*	L40-2282-15	SMALL FIXED INDUCTOR(.22UH)		
L26			L40-2292-15	SMALL FIXED INDUCTOR(2.2UH)		
L27		*	L40-2282-15	SMALL FIXED INDUCTOR(.22UH)		
L28 -30		*	L34-4263-05	COIL		
L31		*	L40-2282-15	SMALL FIXED INDUCTOR(.22UH)		
L32		*	L40-1292-15	SMALL FIXED INDUCTOR(1.2UH)		
L33		*	L40-2282-15	SMALL FIXED INDUCTOR(.22UH)		
L34 -36			L34-2189-05	COIL		
L37		*	L40-2282-15	SMALL FIXED INDUCTOR(.22UH)		
L38		*	L40-1292-15	SMALL FIXED INDUCTOR(1.2UH)		
L39		*	L40-2282-15	SMALL FIXED INDUCTOR(.22UH)		
L41			L40-1021-13	SMALL FIXED INDUCTOR(1UH)		
L42			L40-4791-14	SMALL FIXED INDUCTOR(4.7UH)		
L43			L40-1021-13	SMALL FIXED INDUCTOR(1UH)		
L44			L40-4701-14	SMALL FIXED INDUCTOR(47UH)		
L47			L40-1001-15	SMALL FIXED INDUCTOR(10UH)		
L48			L19-0324-05	BALUN TRANSFORMER		
L49			L40-1021-14	SMALL FIXED INDUCTOR		
L50		*	L34-4264-05	COIL		
L51		*	L34-4265-05	COIL		
L52			L19-0324-05	BALUN TRANSFORMER		
L53			L19-0332-05	BALUN TRANSFORMER		
L54			L40-2782-14	SMALL FIXED INDUCTOR(.27UH)		
L55			L40-2282-14	SMALL FIXED INDUCTOR(.22UH)		
L56			L19-0324-05	BALUN TRANSFORMER		
L57			L39-0455-05	TOROIDAL COIL		
L58			L39-0454-05	TOROIDAL COIL		
L59			L34-4222-05	COIL		
L60			L34-4007-05	COIL		
L61			L34-4006-05	COIL		

E: Scandinavia & Europe K: USA P: Canada W: Europe

U: PX(Far East, Hawaii) T: England M: Other Areas

UE: AAFES(Europe) X: Australia

△ indicates safety critical components.

# TS-850S

## PARTS LIST

\* New Parts

Parts without Parts No. are not supplied.

Les articles non mentionnes dans le Parts No. ne sont pas fournis.

Telle ohne Parts No. werden nicht geliefert.

RF UNIT (X44-3120-00)

Ref. No. 参照番号	Address 位置	New Parts 新	Parts No. 部品番号	Description 部品名 / 規格	Desti- nation 仕 向	Re- marks 備考
L62			L34-4007-05	COIL		
L63			L40-1011-14	SMALL FIXED INDUCTOR(100UH)		
L64			L34-0536-05	COIL		
L65			L34-0781-05	COIL		
L66			L34-4209-05	COIL		
L67			L34-0943-05	COIL		
L68 ,69		*	L34-4266-05	COIL		
L70 ,71			L34-0536-05	COIL		
L72 ,73			L34-0941-05	COIL		
L74 -76			L34-0536-05	COIL		
L77			L34-0781-05	COIL		
L78			L40-1001-14	SMALL FIXED INDUCTOR(10UH)		
L79			L34-0943-05	COIL		
L80			L34-4207-05	COIL		
L81			L34-4206-05	COIL		
L82			L34-4190-05	COIL		
L83			L34-4211-05	COIL		
L84			L34-4190-05	COIL		
L85			L19-0347-05	BALUN TRANSFORMER		
L86			L40-1011-14	SMALL FIXED INDUCTOR(63UH)		
L87			L34-4190-05	COIL		
L88			L19-0324-05	BALUN TRANSFORMER		
L89 ,90			L40-4701-14	SMALL FIXED INDUCTOR(47UH)		
L91			L39-0454-05	TOROIDAL COIL		
L92			L40-4701-14	SMALL FIXED INDUCTOR(47UH)		
L93			L40-2282-14	SMALL FIXED INDUCTOR(.22UH)		
L94			L40-1001-15	SMALL FIXED INDUCTOR		
L95			L40-1011-15	SMALL FIXED INDUCTOR(100UH)		
L96 -99			L40-4701-14	SMALL FIXED INDUCTOR(47UH)		
L100			L40-1021-15	SMALL FIXED INDUCTOR(1UH)		
L101			L40-1011-15	SMALL FIXED INDUCTOR(100UH)		
L102			L40-1501-48	SMALL FIXED INDUCTOR(15UH)		
L103			L40-1011-14	SMALL FIXED INDUCTOR(100UH)		
L104			L40-4782-48	SMALL FIXED INDUCTOR(.47UH)		
L105,106			L40-1011-48	SMALL FIXED INDUCTOR(100UH)		
L107			L40-1011-14	SMALL FIXED INDUCTOR(100UH)		
L108		*	L40-1282-48	SMALL FIXED INDUCTOR(12UH)		
L501			L40-2211-48	SMALL FIXED INDUCTOR(220UH)		
L601			L40-1021-15	SMALL FIXED INDUCTOR(1UH)		
L602			L34-0535-05	COIL		
L603			L34-0536-05	COIL		
L604			L40-1021-15	SMALL FIXED INDUCTOR(1MH)		
L605			L40-1021-11	SMALL FIXED INDUCTOR(1MH)		
L606		*	L40-1021-15	SMALL FIXED INDUCTOR(1MH)		
XF1			L71-0401-05	CRYSTAL FILTER(MCF)		
XF2			L71-0222-05	CRYSTAL FILTER		
XF3			L71-0266-05	CRYSTAL FILTER(MCF)		
T			N30-3010-46	PAN HEAD MACHINE SCREW		
R1 -10			RK73FB2AXXXJ	CHIP R		
R11			RK73EB2B330J	CHIP R 33 J 1/8W		
R12			RK73FB2A121J	CHIP R 120 J 1/10W		
R13			RK73EB2B330J	CHIP R 33 J 1/8W		
R14			RK73FB2A121J	CHIP R 120 J 1/10W		

E: Scandinavia & Europe K: USA P: Canada W: Europe

U: PX(Far East, Hawaii) T: England M: Other Areas

UE: AAFES(Europe) X: Australia

△ indicates safety critical components.

# TS-850S

## PARTS LIST

\* New Parts

Parts without Parts No. are not supplied.

Les articles non mentionnes dans le Parts No. ne sont pas fournis.

Telle ohne Parts No. werden nicht geliefert.

RF UNIT (X44-3120-00)

Ref. No. 参照番号	Address 位置	New Parts 新	Parts No. 部品番号	Description 部品名 / 規格	Desti- nation 仕向	Re- marks 備考
R15			RK73EB2B330J	CHIP R 33 J 1/8W		
R16 -18			RK73FB2AXXXJ	CHIP R		
R19			RK73EB2B330J	CHIP R 33 J 1/8W		
R20			RK73FB2A121J	CHIP R 120 J 1/10W		
R21		*	RK73EB2B330J	CHIP R 33 J 1/8W		
R22 -24			RK73FB2AXXXJ	CHIP R		
R25		*	RK73EB2B330J	CHIP R 33 J 1/8W		
R26 -28			RK73FB2AXXXJ	CHIP R		
R29		*	RK73EB2B330J	CHIP R 33 J 1/8W		
R30 -97			RK73FB2AXXXJ	CHIP R		
R98			R92-0670-05	CHIP R 0 0HM		
R99 -242			RK73FB2AXXXJ	CHIP R		
R243			R92-0670-05	CHIP R 0 0HM		
R244-248			RK73FB2AXXXJ	CHIP R		
R249			R92-0670-05	CHIP R 0 0HM		
R250-297			RK73FB2AXXXJ	CHIP R		
R298, 299			R92-0670-05	CHIP R 0 0HM		
R301			R92-0670-05	CHIP R 0 0HM		
R302-644			RK73FB2AXXXJ	CHIP R		
VR1			R12-6421-05	TRIM POT. 4.7K		
VR2			R12-6427-05	TRIM POT. 47K		
VR3		*	R12-6417-05	TRIMMING POT. 1K		
VR4			R12-6427-05	TRIM POT. 47K		
VR5 ,6			R12-6423-05	TRIM POT. 10K		
VR7 ,8			R12-6427-05	TRIM POT. 47K		
VR9 ,10			R12-6421-05	TRIM POT. 4.7K		
VR11-14			R12-6423-05	TRIM POT. 10K		
VR501-503		*	R12-6740-05	TRIMMING POT. 6K		
VR601		*	R12-1090-05	TRIMMING POT. 4.7K		
VR602, 603			R12-3127-05	TRIMMING POT. 10K		
K1 ,2			SS1-1428-05	RELAY		
K3			SS1-1420-05	RELAY		
K4			SS1-1428-05	RELAY		
S1			S31-1411-05	SLIDE SWITCH		
S2 ,3			S31-2419-05	SLIDE SWITCH		
S501			S59-4401-05	DIP SWITCH		
D1 ,2			LF801	DIODE		
D3			M1204	DIODE		
D4 -27			RLS135	DIODE		
D28 ,29			RLS73	DIODE		
D30			RLZJ4.7B	DIODE		
D31			RLS135	DIODE		
D32			DAN202K	DIODE		
D33 -38			RLS135	DIODE		
D39			DAN202K	DIODE		
D40 -58			RLS135	DIODE		
D59			RLZJ4.7B	DIODE		
D60			RLS135	DIODE		
D61 ,62			RLS73	DIODE		
D63			LT8001P	DIODE		
D64 -66			RLS135	DIODE		
D67 -69			RLS73	DIODE		
D70 ,71			DAN202K	DIODE		
D73		*	RLZJ10C	DIODE		

E: Scandinavia & Europe K: USA P: Canada W: Europe

U: PX(Far East, Hawaii) T: England M: Other Areas

UE: AAFES(Europe) X: Australia

△ indicates safety critical components.



# TS-850S

## PARTS LIST

× New Parts

Parts without Parts No. are not supplied.

Les articles non mentionnés dans le Parts No. ne sont pas fournis.

Telle ohne Parts No. werden nicht geliefert.

RF UNIT (X44-3120-00)

Ref. No. 参照番号	Address 位置	New Parts 新	Parts No. 部品番号	Description 部品名 / 規格	Desti- nation 仕向	Re- marks 備考
D74			LT8001P	DIODE		
D75			RLZ3.6B	DIODE		
D76			RLS73	DIODE		
D77			RLZJ12B	DIODE		
D78			RLS73	DIODE		
D79			LFB01	DIODE		
D80			DAN202K	DIODE		
D81 -83			RLS73	DIODE		
D84			RLZJ4.7B	DIODE		
D85			RLS73	DIODE		
D86			DAN235K	DIODE		
D87 ,88			RLS73	DIODE		
D89			1SV128	DIODE		
D90			LFB01	DIODE		
D91 ,92			HSM88AS	DIODE		
D93			V08(G)	DIODE		
D94			RLS245	DIODE		
D96			1SS226	DIODE		
D97 ,98			RLS135	DIODE		
D100			1SS226	DIODE		
D101,102			RLS135	DIODE		
D601			HSM276S	DIODE		
D602-604			DAN202K	DIODE		
D605		*	RLZJ6.2B	DIODE		
IC1			SN74LS145N	IC(BCD TO DECIMAL DECODER/DRIV		
IC2			TC4011BP	IC(NAND X4)		
IC3			TC9174F	IC(CMOS I/O)		
IC4			UPC1037HA	IC(DUBBLE BALANCE MODULATOR)		
IC5			NJM2902M	IC(OP AMP X4)		
IC601			TC4538BF	IC(ONE SHOT MULT)		
IC602		*	TC4023BF	IC		
IC603			TC4066BF	IC(BILATERAL SWITCH X4)		
Q1			3SK131(M)	FET		
Q2 ,3			2SK125-5	FET		
Q4			2SC2712(Y)	TRANSISTOR		
Q5			2SC2954(QK)	TRANSISTOR		
Q6 ,7			DTC143TK	DIGITAL TRANSISTOR		
Q8 -11			2SK520(K44)	FET		
Q12			2SD1624S	TRANSISTOR		
Q13			3SK131(M)	FET		
Q14			2SC2714(Y)	TRANSISTOR		
Q15			3SK131(M)	FET		
Q16 ,17			2SK520(K44)	FET		
Q18			2SC2714(Y)	TRANSISTOR		
Q19			DTC124EK	DIGITAL TRANSISTOR		
Q20			3SK131(M)	FET		
Q21			2SC2714(Y)	TRANSISTOR		
Q22			DTC124EK	DIGITAL TRANSISTOR		
Q23 ,24			3SK131(M)	FET		
Q26 ,27			3SK131(M)	FET		
Q28			2SC2954(QK)	TRANSISTOR		
Q29			2SC2712(Y)	TRANSISTOR		
Q30 -35			DTC124EK	DIGITAL TRANSISTOR		
Q36 -39			2SC2712(Y)	TRANSISTOR		
Q40			2SK208(GR)	FET		

E: Scandinavia & Europe K: USA P: Canada W: Europe

U: PX(Far East, Hawaii) T: England M: Other Areas

UE: AAFES(Europe) X: Australia

△ indicates safety critical components.

# TS-850S

## PARTS LIST

× New Parts

Parts without Parts No. are not supplied.

Les articles non mentionnés dans le Parts No. ne sont pas fournis.

Telle ohne Parts No. werden nicht geliefert.

RF UNIT (X44-3120-00)

FINAL UNIT (X45-1470-02)

Ref. No. 参照番号	Address 位置	New Parts 新	Parts No. 部品番号	Description 部品名 / 規格	Desti- nation 仕向	Re- marks 備考
Q40			2SK208(Y)	FET		
Q41			2SC2712(Y)	TRANSISTOR		
Q42			DTC124EK	DIGITAL TRANSISTOR		
Q43			2SA1213(Y)	TRANSISTOR		
Q45 -47			DTA124EK	DIGITAL TRANSISTOR		
Q48 ,49			DTC124EK	DIGITAL TRANSISTOR		
Q50			DTA124EK	DIGITAL TRANSISTOR		
Q51 ,52			DTC124EK	DIGITAL TRANSISTOR		
Q501 ,502			DTC124EK	DIGITAL TRANSISTOR		
Q503			2SD1757K	TRANSISTOR		
Q601-603			2SC2714(Y)	TRANSISTOR		
Q604 ,605			2SC2712(Y)	TRANSISTOR		
Q606-608			2SA1162(Y)	TRANSISTOR		
Q609			2SC2712(Y)	TRANSISTOR		
Q610			2SD1757K	TRANSISTOR		
Q611			DTA144EK	DIGITAL TRANSISTOR		
Q612			DTC124EK	DIGITAL TRANSISTOR		
Q613			DTC143TK	DIGITAL TRANSISTOR		
TH1			157-302-53008	THERMISTOR 3K		
TH2		*	157-501-53009	THERMISTOR 500		
Z1		*	X59-3900-00	MODULE UNIT(AIP-SW)		
Z601		*	X59-3910-00	MODULE UNIT(NB2)		
Z602			X59-1100-00	MODULE UNIT(DC-DC)		
Z603			X59-3000-03	MODULE UNIT(FM MIC)		
<b>FINAL UNIT (X45-1470-02)</b>						
C1			CK45B1H561K	CERAMIC 560PF K		
C2			CK45F1H103Z	CERAMIC 0.010UF Z		
C3			CK45F1H223Z	CERAMIC 0.022UF Z		
C4			CK45B1H102K	CERAMIC 1000PF K		
C5 -7			CK45F1H473Z	CERAMIC 0.047UF Z		
C8 ,9			CK45F1H223Z	CERAMIC 0.022UF Z		
C11			CM93D2H681J	MICA 680PF J		
C12 ,13			C91-1004-05	CHIP C 0.0068UF J		
C14			CM73F2H122J	CHIP C 1200PF J		
C15			CC45SL2H151J	CERAMIC 150PF J		
C17			CK45F1H473Z	CERAMIC 0.047UF Z		
C18			CE04EW1C100M	ELECTRO 10UF 16WV		
C19			CK45F1H223Z	CERAMIC 0.022UF Z		
C20			CE04EW1E470M	ELECTRO 47UF 25WV		
C21			CK45F1H223Z	CERAMIC 0.022UF Z		
C22			CK45B1H102K	CERAMIC 1000PF K		
C23			CK45F1H473Z	CERAMIC 0.047UF Z		
C24			CE04EW1C100M	ELECTRO 10UF 16WV		
C25			CE04EW1E101M	ELECTRO 100UF 25WV		
C26			CK45F1H473Z	CERAMIC 0.047UF Z		
C27			CQ92M1H154K	MYLAR 0.15UF K		
C28 ,29			CK45F1H103Z	CERAMIC 0.010UF Z		
C32			CK45F1H223Z	CERAMIC 0.022UF Z		
C33			CE04EW1E470M	ELECTRO 47UF 25WV		
C35			CK45F1H473Z	CERAMIC 0.047UF Z		
MC1			E04-0157-05	RF COAXIAL CABLE RECEPTACLE		
			E23-0401-05	TERMINAL		
			E23-0433-05	TERMINAL (GND)		
			E40-0273-05	PIN CONNECTOR		

E: Scandinavia & Europe K: USA P: Canada W: Europe

U: PX(Far East, Hawaii) T: England M: Other Areas

UE: AAFES(Europe) X: Australia

 indicates safety critical components.

## PARTS LIST

× New Parts

Parts without Parts No. are not supplied.

Les articles non mentionnes dans le Parts No. ne sont pas fournis.

Telle ohne Parts No. werden nicht geliefert.

FINAL UNIT (X45-1470-02)

Ref. No. 参照番号	Address 位置	New Parts 新	Parts No. 部品番号	Description 部品名 / 規格	Desti- nation 仕向	Re- marks 備考
			F01-0981-01 F29-0014-05	HEAT SINK INSULATOR		
L1			L40-1511-13	SMALL FIXED INDUCTOR		
L2 ,3			L33-0651-05	CHOKER COIL		
L4 ,5			L33-0232-05	CHOKER COIL		
L6 ,7			L33-0617-05	CHOKER COIL		
L8 -10			L33-0651-05	CHOKER COIL		
L11			L33-0617-05	CHOKER COIL		
L12			L40-1011-13	SMALL FIXED INDUCTOR		
L13			L39-0424-05	COIL		
T2			L19-0338-05	BALUN TRANSFORMER		
T2			L19-0340-05	BALUN TRANSFORMER		
T3			L19-0342-05	BALUN TRANSFORMER		
T4			L19-0363-05	BALUN TRANSFORMER		
U			N30-3008-46	PAN HEAD MACHINE SCREW		
N			N87-3006-46	BRAZIER HEAD TAPTITE SCREW		
R3		*	RS14DB2H3R9J	FL-PROOF RS 3.9 J 1/2W		
R4			RD14BB2C331J	RD 330 J 1/6W		
R5			RD14BB2C681J	RD 680 J 1/6W		
R7			RD14CB2E152J	RD 1.5K J 1/4W		
R7 ,8			RD14CB2E150J	RD 15 J 1/4W		
R9 ,10			RS14DB2H181J	FL-PROOF RS 180 J 1/2W		
R11 -14			RS14AB3A5R6J	FL-PROOF RS 5.6 J 1W		
R15 ,16		*	RS14AB3A5R6J	FL-PROOF RS 5.6 J 1W		
R17 ,18			RD14BB2C681J	RD 680 J 1/6W		
R19						
R20			RD14BB2C101J	RD 100 J 1/6W		
R21			RD14BB2C151J	RD 150 J 1/6W		
R22			RD14BB2C103J	RD 10K J 1/6W		
R23 ,24			RD14BB2C562J	RD 5.6K J 1/6W		
R25			RD14BB2C681J	RD 680 J 1/6W		
R26			RD14CB2C562J	RD 5.6K J 1/6W		
R27			RD14BB2C222J	RD 2.2K J 1/6W		
R28			RD14BB2C223J	RD 22K J 1/6W		
R29			RD14BB2C103J	RD 10K J 1/6W		
R30			RD14CB2C103J	RD 10K J 1/6W		
R31			RD14CB2E101J	RD 100 J 1/4W		
R32			RD14CB2C561J	RD 560 J 1/6W		
R33			RS14DB2H100J	FL-PROOF RS 10 J 1/2W		
R34			RD14BB2C103J	RD 10K J 1/6W		
VR1 ,2			R12-1406-05	TRIMMING POT.		
W9			R92-0150-05	JUMPER REST 0 OHM		
D1			KB-365	VARISTOR		
D2 ,3			SV03YS	VARISTOR		
D4			1SS133	DIODE		
Q1			2SC2075	TRANSISTOR		
Q2 ,3			2SC2509	TRANSISTOR		
Q4 ,5			2SC2879	TRANSISTOR		
Q6 ,7			2SD1406(Y)	TRANSISTOR		
Q8			2SC1815(Y)	TRANSISTOR		
Q9			AN6551	IC(OP AMP X2)		
TH1			SDT1000	THERMISTOR		

E: Scandinavia & Europe K: USA P: Canada W: Europe

U: PX(Far East, Hawaii) T: England M: Other Areas

UE: AAFES(Europe) X: Australia

▲ indicates safety critical components.

# TS-850S

## PARTS LIST

\* New Parts

Parts without Parts No. are not supplied.

Les articles non mentionnes dans le Parts No. ne sont pas fournis.

Teile ohne Parts No. werden nicht geliefert.

FINAL UNIT (X45-1470-02)

DIGITAL UNIT (X46-308X-XX)

Ref. No. 参照番号	Address 位置	New Parts 新	Parts No. 部品番号	Description 部品名 / 規格	Desti- nation 仕向	Re- marks 備考
TH1			5T41L	THERMISTOR		
<b>DIGITAL UNIT (X46-308X-XX) 0-11: K,K2,P,P2 0-21: M,M2 0-22: M3,M4 0-71: X,X2 2-71: E,E2 2-72: E3,E4</b>						
C1			CK73FF1E104Z	CHIP C 0.1UF Z		
C2 ,3			CK73FB1E103K	CHIP C 0.01UF K		
C4			CK73FF1E104Z	CHIP C 0.1UF Z		
C5 -9			CK73FB1E103K	CHIP C 0.01UF K		
C10 -20			CK73FB1H102K	CHIP C 1000PF K		
C21 ,22			CK73FB1E103K	CHIP C 0.01UF K		
C23			CK73FB1H102K	CHIP C 0.01UF K		
C24 -47			CK73FB1EXXXK	CHIP C		
C48			CK73FF1E104Z	CHIP C 0.1UF Z		
C49 ,50			CK73FB1H102K	CHIP C 1000PF K		
C51 ,52			CK73FF1E104Z	CHIP C 0.1UF Z		
C53 -56			CK73FB1H102K	CHIP C 1000PF K		
C57 -59			CK73FB1E103K	CHIP C 0.01UF K		
C60			CK73FF1E104Z	CHIP C 0.1UF Z		
C61 -71			CK73FB1E103K	CHIP C 0.01UF K		
C72 -83			CK73FB1HXXXK	CHIP C		
C84 -88			CK73FB1E103K	CHIP C 0.01UF K		
C89 -91			CK73FB1H102K	CHIP C 1000PF K		
C92 -100			CK73FB1E103K	CHIP C 0.01UF K		
C101			CK73FF1E104Z	CHIP C 0.1UF Z		
C102-115			CK73FB1E103K	CHIP C 0.01UF K		
C118			CK73FF1E104Z	CHIP C 0.1UF Z		
C119			CK73FB1E103K	CHIP C 0.01UF K		
C120,121			CK73FF1E104Z	CHIP C 0.1UF Z		
C122-124			CK73FB1E103K	CHIP C 0.01UF K		
C125-130			CK73FB1H471K	CHIP C 470PF K		
C132			CK73FF1E104Z	CHIP C 0.1UF Z		
C133			CK73FB1E223K	CHIP C 0.022UF K		
C134,135			CE04EW1C470M	ELECTRO 47UF 16WV		
C136			CK73FF1E473Z	CHIP C 0.047UF Z		
C137			CK73FB1E223K	CHIP C 0.022UF K		
C138,139			CE04EW1C470M	ELECTRO 47UF 16WV		
C140			CK73FF1E473Z	CHIP C 0.047UF Z		
C141-146			CK73FB1H102K	CHIP C 1000PF K		
C147			CK73FF1E104Z	CHIP C 0.1UF Z		
C148-151			CK73FB1H102K	CHIP C 1000PF K		
C152			CE04EW1C101M	ELECTRO 100UF 16WV		
C153			CK73FF1E104Z	CHIP C 0.1UF Z		
C154-157			CK73FB1H102K	CHIP C 1000PF K		
C158-166			CK73FB1E103K	CHIP C 0.01UF K		
C167			CK73FF1E104Z	CHIP C 0.1UF Z		
C168-170			CK73FB1E103K	CHIP C 0.01UF K		
C171			CK73FF1E104Z	CHIP C 0.1UF Z		
C172			CE04EW1C101M	ELECTRO 100UF 16WV		
C173-180			CK73FB1E103K	CHIP C 0.01UF K		
C181			CE04EW1C101M	ELECTRO 100UF 16WV		
C182			CK73FF1E104Z	CHIP C 0.1UF Z		
C183			CK73FB1E103K	CHIP C 0.01UF K		
C184,185			CC73FCH1H100D	CHIP C 10PF D		
C186			CK73FB1E103K	CHIP C 0.01UF K		
C190			CE04EW1C101M	ELECTRO 100UF 16WV		
C191-194			CK73FF1E104Z	CHIP C 0.1UF Z		

E: Scandinavia & Europe K: USA P: Canada W: Europe

U: PX(Far East, Hawaii) T: England M: Other Areas

UE: AAFES(Europe) X: Australia

 indicates safety critical components.

## PARTS LIST

× New Parts

Parts without Parts No. are not supplied.

Les articles non mentionnés dans le Parts No. ne sont pas fournis.

Telle ohne Parts No. werden nicht geliefert.

DIGITAL UNIT (X46-308X-XX)

Ref. No. 参照番号	Address 位置	New Parts 新	Parts No. 部品番号	Description 部品名 / 規格	Desti- nation 向	Re- marks 備考
C195			C90-2041-05	ELECTRØ 10UF 10WV		
C196			CE04EW1C101M	ELECTRØ 100UF 16WV		
C197			CK73FF1E104Z	CHIP C 0.1UF Z		
C198			CE04EW1C101M	ELECTRØ 100UF 16WV		
C199-201			CK73FF1E104Z	CHIP C 0.1UF Z		
C202			CK73FB1H221K	CHIP C 220PF K		
C203-207			CC73FCH1H101J	CHIP C 100PF J		
C208			CE04EW1C101M	ELECTRØ 100UF 16WV		
C209			CK73FF1E104Z	CHIP C 0.1UF Z		
C210-216			CK73FB1HXXXK	CHIP C		
C217			CC73FCH1H101J	CHIP C 100PF J		
C222-224			CK73FB1H331K	CHIP C 330PF K		
C229			CK73FB1E103K	CHIP C 0.01UF K		
C230-233			CK73FB1H102K	CHIP C 1000PF K		
C234			CK73FF1E104Z	CHIP C 0.1UF Z		
C235, 236			CK73FB1E103K	CHIP C 0.01UF K		
C237, 238			CK73FB1H102K	CHIP C 1000PF K		
C239, 240			CK73FB1E103K	CHIP C 0.01UF K		
C241-244			CK73FB1H102K	CHIP C 1000PF K		
C245-248			CK73FB1E103K	CHIP C 0.01UF K		
C249			CK73FF1E104Z	CHIP C 0.1UF Z		
C250-258			CK73FB1E103K	CHIP C 0.01UF K		
C259-266			CC73FCH1H101J	CHIP C 100PF J		
C267-285			CK73FB1H331K	CHIP C 330PF K		
C286, 287			CK73FF1E104Z	CHIP C 0.1UF Z		
C288			CE04EW1C101M	ELECTRØ 100UF 16WV		
C289, 290			CK73FB1E103K	CHIP C 0.01UF K		
C291			CE04EW1C101M	ELECTRØ 100UF 16WV		
C292			CK73FF1E104Z	CHIP C 0.1UF Z		
C293, 294			CC73FCH1H220J	CHIP C 22PF J		
C295			CQ92M1H563K	MYLAR 0.056UF K		
C296-301			CK73FB1EXXXK	CHIP C		
C302-304			CK73FF1E104Z	CHIP C 0.1UF Z		
C305			CE04EW1C101M	ELECTRØ 100UF 16WV		
C307, 308			CK73FB1H102K	CHIP C 1000PF K		
C309-311			CK73FB1EXXXK	CHIP C		
C312			CK73FB1H102K	CHIP C 1000PF K		
C313			CK73FF1E104Z	CHIP C 0.1UF Z		
C401			CK73FB1H102K	CHIP C 1000PF K		
C402			CK73FF1E104Z	CHIP C 0.1UF Z		
C403-406			CK73FB1E103K	CHIP C 0.01UF K		
C501-503			CK73FB1H102K	CHIP C 1000PF K		
C601, 602			CE04EW1E102M	ELECTRØ 1000UF 25WV		
C603-605			CK73FB1E103K	CHIP C 0.01UF K		
C606			CE04EW1E471M	ELECTRØ 470UF 25WV		
C607, 608			CE04EW1C470M	ELECTRØ 47UF 16WV		
C609			CE04EW1C101M	ELECTRØ 100UF 16WV		
C610			C90-2046-05	ELECTRØ 22UF 10WV		
CN1			E23-0623-04	TERMINAL		
CN2		*	E40-5334-05	FPC CONNECTØR(24P)		
CN3		*	E40-5481-05	FPC CONNECTØR(28P)		
CN4			E40-3239-05	PIN CONNECTØR(4P)		
			E40-5467-05	FPC CONNECTØR(10P)		
CN5			E40-5339-05	FPC CONNECTØR(25P)		

E: Scandinavia & Europe K: USA P: Canada W: Europe

U: PX(Far East, Hawaii) T: England M: Other Areas

UE: AAFES(Europe) X: Australia

 indicates safety critical components.

# TS-850S

## PARTS LIST

\* New Parts

Parts without Parts No. are not supplied.

Les articles non mentionnés dans le Parts No. ne sont pas fournis.

Teile ohne Parts No. werden nicht geliefert.

DIGITAL UNIT (X46-308X-XX)

Ref. No. 参照番号	Address 位置	New Parts 新	Parts No. 部品番号	Description 部品名 / 規格	Desti- nation 仕向	Re- marks 備考
CN6 ,7		*	E40-5479-05	FPC CONNECTOR(18P)		
CN8			E40-3309-05	PIN CONNECTOR(12P)		
CN9		*	E40-5484-05	PIN CONNECTOR(26P)		
CN10			E40-3243-05	PIN CONNECTOR(8P)		
CN11			E02-2009-05	IC SOCKET(28P)		
CN12			E40-3237-05	PIN CONNECTOR(2P)		
CN401			E40-3242-05	PIN CONNECTOR(7P)		
CN501			E40-3239-05	PIN CONNECTOR(4P)		
CN502			E40-3237-05	PIN CONNECTOR(2P)		
CN601			E23-0401-05	TERMINAL		
CN602		*	E40-5488-05	PIN CONNECTOR(2P)		
CN603		*	E40-5488-05	PIN CONNECTOR(2P)		
CN604			E40-3241-05	PIN CONNECTOR(6P)		
CN605			E40-3237-05	PIN CONNECTOR(2P)		
CN606			E40-0773-05	PIN CONNECTOR(7P)		
CN607			E40-3243-05	PIN CONNECTOR(8P)		
CN608			E40-5469-05	PIN CONNECTOR(12P)		
CN609			E40-3239-05	PIN CONNECTOR(4P)		
J401			E06-0858-15	CYLINDRICAL RECEPTACLE(8P)		
J501			E13-0362-05	PIN JACK		
W501		*	E37-0127-05	WIRE WITH CONNECTOR(RTK)		
W601		*	E37-0109-15	WIRE WITH CONNECTOR		
W602		*	E37-0108-15	WIRE WITH CONNECTOR(DC IN)		
W603		*	E37-0111-05	WIRE WITH CONNECTOR		
W605		*	E37-0110-15	WIRE WITH CONNECTOR(14F)		
W609			E40-3239-05	PIN CONNECTOR(4P)		
		*	F01-0982-04	HEAT SINK(IC25,26)		
100	3F		G02-0574-04	SPRING(IC25,26)		
		*	G13-1308-04	FORMED PLATE		
		*	J21-4327-04	MOUNTING HARDWARE(RCA JACK)		
L1 ,2			L40-2211-15	SMALL FIXED INDUCTOR(220UH)		
L3 ,4			L40-1011-12	SMALL FIXED INDUCTOR(100UH)		
L5 ,6			L40-4711-12	SMALL FIXED INDUCTOR(470UH)		
L7 ,9			L40-1011-12	SMALL FIXED INDUCTOR(100UH)		
L10			L40-4711-12	SMALL FIXED INDUCTOR(470UH)		
L11 ,12		*	L40-4710-15	SMALL FIXED INDUCTOR(47UH)		
L13			L40-1011-12	SMALL FIXED INDUCTOR(100UH)		
L14			L40-1011-15	SMALL FIXED INDUCTOR(100UH)		
L15 ,16			L40-2282-19	SMALL FIXED INDUCTOR(.22UH)		
L17 ,18			L40-1092-12	SMALL FIXED INDUCTOR(1UH)		
L19			L40-1011-12	SMALL FIXED INDUCTOR(100UH)		
L20			L40-4782-12	SMALL FIXED INDUCTOR(.47UH)		
L601			L15-0016-05	LOW-FREQUENCY CHOKE COIL		
L602			L40-1011-12	SMALL FIXED INDUCTOR(100UH)		
X1			L77-1380-05	CRYSTAL RESONATOR(11.0592MHZ)		
X2			L77-1333-05	CRYSTAL RESONATOR(4.19MHZ)		
CP1			R90-0455-05	MULTI-COMP 4.7KX8 J 1/4W		
R1 -230			RK73FB2AXXXJ	CHIP R		
R231,232			RK73FB2A222F	CHIP R 2.2K F		
R233-235			RK73FB2AXXXJ	CHIP R		
R601			RS14AB3A121J	FL-PROOF RS 120 J 1W		

E: Scandinavia & Europe K: USA P: Canada W: Europe

U: PX(Far East, Hawaii) T: England M: Other Areas

UE: AAFES(Europe) X: Australia

 indicates safety critical components.

# TS-850S

## PARTS LIST

× New Parts

Parts without Parts No. are not supplied.

Les articles non mentionnés dans le Parts No. ne sont pas fournis.

Teile ohne Parts No. werden nicht geliefert.

DIGITAL UNIT (X46-308X-XX)

Ref. No. 参照番号	Address 位置	New Parts 新	Parts No. 部品番号	Description 部品名 / 規格	Desti- nation 仕 向	Re- marks 備考
R602-603			RK73FB2AXXXJ	CHIP R		
D1 -5			RLS73	DIODE		
D6 ,7			1SS133	DIODE		
D8			1SS133	DIODE	EE2E3	
D8			1SS133	DIODE	E4	
D9			1SS133	DIODE	MM2M3	
D9			1SS133	DIODE	M4E2	
D10			1SS133	DIODE	XX2E3	
D10			1SS133	DIODE	E4	
D11			1SS133	DIODE	KK2PP2	
D11			1SS133	DIODE	XX2MM2	
D11			1SS133	DIODE	EE2E3	
D11			1SS133	DIODE	E4	
D12			RLS73	DIODE	XX2	
D14			RLS73	DIODE		
D17 -20			RLS73	DIODE		
D22			RLS73	DIODE		
D601			SG-5L(R)	DIODE		
D602			RLS73	DIODE		
D603			UZP4.7B	DIODE		
IC1			MB89363B	IC(MICROPROCESSOR)		
IC2			CXD1095Q	IC(1/0)		
IC3			MB89363B	IC(MICROPROCESSOR)		
IC4			TC4052BF	IC(4CH MPX/DE-MPX)		
IC5			MB4052	IC(4CH 8BIT A/D CONVERTER(ADC)		
IC6			UPD78C10G-36	IC(MICROPROCESSOR)		
IC10			TC74HC573AF	IC(LATCH)		
IC11			TC74HC138AF	IC(DECODER)		
IC12			TC4581F	IC(UNLOCK COMPALETER)		
IC13			TC5564APL-15	IC(8KX8 RAM)		
IC14			LZ92K37	IC(COUNTER)		
IC15,16			TC45584F	IC(SCHMITT TRIGGER)		
IC17			SN7404N	IC(6-CIRCUIT INVERTER)		
IC18		*	C256B-15XF1JBL1	IC		
IC20			TC4011BF	IC(NAND X4)		
IC21		*	P008GB-3B4JBM1	IC		
IC22		*	CAT35C102KI	IC(EEPROM 2K)		
IC23		*	MB3780A	IC		
IC24			TC45U69F	IC(INVERTER GATE)		
IC25			UPC7808H	IC(VOLTAGE REGULATOR/ +8V)		
IC26			UPC7805H	IC(VOLTAGE REGULATOR/ +5V)		
IC601,602			AN78N08	IC(VOLTAGE REGULATOR/ +35V)		
IC601,602			UPC7808H	IC(VOLTAGE REGULATOR/ +35V)		
IC603			LA5010	IC(LOW SATURATION REGULATOR)		
Q1			DTC143EK	DIGITAL TRANSISTOR		
Q2 -6			FMG1	TRANSISTOR		
Q7			DTC143EK	DIGITAL TRANSISTOR		
Q8			FMG1	TRANSISTOR		
Q9			DTC143EK	DIGITAL TRANSISTOR		
Q10 ,11			FMG1	TRANSISTOR		
Q12 ,13			DTA143EK	DIGITAL TRANSISTOR		
Q14 -16			DTC143EK	DIGITAL TRANSISTOR		
Q19 -21			FMG1	DIGITAL TRANSISTOR		
Q22			DTC114EK	DIGITAL TRANSISTOR		

E: Scandinavia & Europe K: USA P: Canada W: Europe

U: PX(Far East, Hawaii) T: England M: Other Areas

UE: AAFES(Europe) X: Australia

▲ indicates safety critical components.

# TS-850S

## PARTS LIST

× New Parts

Parts without Parts No. are not supplied.

Les articles non mentionnés dans le Parts No. ne sont pas fournis.

Teile ohne Parts No. werden nicht geliefert.

DIGITAL UNIT (X46-308X-XX)

IF UNIT (X48-3080-00)

Ref. No. 参照番号	Address 位置	New Parts 新	Parts No. 部品番号	Description 部品名 / 規格	Desti- nation 仕向	Re- marks 備考
Q23 -26 Q601			DTC143EK 2SC2712(Y)	DIGITAL TRANSISTOR TRANSISTOR		
BA1			W09-0514-05	LITHIUM BATTERY		
<b>IF UNIT (X48-3080-00)</b>						
C1 -6			CK73FB1E103K	CHIP C 0.01UF K		
C7			CK73EF1E474Z	CHIP C 0.47UF Z		
C8			CK73FB1E103K	CHIP C 0.01UF K		
C9			CK73FF1E104Z	CHIP C 0.1UF Z		
C10			CK73EB1E103K	CHIP C 0.01UF K		
C11 ,12			CK73FF1E104Z	CHIP C 0.1UF Z		
C13 -15			CK73FB1E103K	CHIP C 0.01UF K		
C16			CC73FCH1H100J	CHIP C 10PF J		
C17 ,18			CK73FB1E103K	CHIP C 0.01UF K		
C19 -21			CK73FF1E104Z	CHIP C 0.1UF Z		
C22			CK73FB1E103K	CHIP C 0.01UF K		
C23 -28			CK73FF1E104Z	CHIP C 0.1UF Z		
C29 -30			CK73FB1HXXXK	CHIP C		
C31 -33			CK73FF1E104Z	CHIP C 0.1UF Z		
C34			CK73FB1E103K	CHIP C 0.01UF K		
C35			CC73FCH1H101J	CHIP C 100PF J		
C36 ,37			CK73FB1E103K	CHIP C 0.01UF K		
C38			CK73FF1E104Z	CHIP C 0.1UF Z		
C39			CC73FCH1H101J	CHIP C 100PF J		
C40			CK73FB1E103K	CHIP C 0.01UF K		
C41			CK73FF1E104Z	CHIP C 0.1UF Z		
C42 -43			CK73FB1EXXXK	CHIP C		
C44			CE04EW1H010M	ELECTRO 1UF 50WV		
C45 -61			CK73FF1E104Z	CHIP C 0.1UF Z		
C62			CC73FCH1H101J	CHIP C 100PF J		
C63			CK73FB1H102K	CHIP C 1000PF K		
C64			CK73FF1E104Z	CHIP C 0.1UF Z		
C65			CE04EW1A101M	ELECTRO 100UF 10WV		
C66			CK73FF1E104Z	CHIP C 0.1UF Z		
C67			CK73FB1E103K	CHIP C 0.01UF K		
C68 ,69			CC73FCH1H102J	CHIP C 1000PF J		
C70 -72			CK73FB1E103K	CHIP C 0.01UF K		
C73 ,74			CK73FF1E104Z	CHIP C 0.1UF Z		
C75			CK73EB1E103K	CHIP C 0.01UF K		
C76 -79			CK73FF1EXXXZ	CHIP C		
C80			CK73FB1H102K	CHIP C 1000PF K		
C81 ,82			CK73FF1E104Z	CHIP C 0.1UF Z		
C83 ,84			CK73FB1E103K	CHIP C 0.01UF K		
C85			CC73FCH1H101J	CHIP C 100PF J		
C86 -88			CK73FF1E104Z	CHIP C 0.1UF Z		
C89			CC73FCH1H101J	CHIP C 100PF J		
C90			CK73FF1E104Z	CHIP C 0.1UF Z		
C91			CK73FB1E103K	CHIP C 0.01UF K		
C92			CC73FCH1H470J	CHIP C 47PF J		
C93			CC73FSL1H221J	CHIP C 220PF J		
C94			CK73FB1E103K	CHIP C 0.01UF K		
C95			CE04EW1A101M	ELECTRO 100UF 10WV		
C96			CC73FSL1H221J	CHIP C 220PF J		
C97			CE04EW1A101M	ELECTRO 100UF 10WV		
C98			CE04EW1HR47M	ELECTRO 0.47UF 50WV		

E: Scandinavia & Europe K: USA P: Canada W: Europe

U: PX(Far East, Hawaii) T: England M: Other Areas

UE: AAFES(Europe) X: Australia

 indicates safety critical components.



## PARTS LIST

× New Parts

Parts without Parts No. are not supplied.

Les articles non mentionnes dans le Parts No. ne sont pas fournis.

Telle ohne Parts No. werden nicht geliefert.

IF UNIT (X48-3080-00)

Ref. No. 参照番号	Address 位置	New Parts 新	Parts No. 部品番号	Description 部品名 / 規格	Desti- nation 仕 向	Re- marks 備考
C99			CK73FF1E104Z	CHIP C 0.1UF Z		
C100			CE04EW1A101M	ELECTRO 100UF 10WV		
C101			CE04EW1H010M	ELECTRO 1.0UF 50WV		
C102,103			CK73FF1E104Z	CHIP C 0.1UF Z		
C104			CE04EW1H010M	ELECTRO 1.0UF 50WV		
C105			CE04EW1H2R2M	ELECTRO 2.2UF 50WV		
C106			CK73FB1E223K	CHIP C 0.022UF K		
C107			CC73FCH1H330J	CHIP C 33PF J		
C108			CK73FB1H102K	CHIP C 1000PF K		
C109-111			CC73FSL1HXXXJ	CHIP C		
C112			CK73FB1E104K	CHIP C 0.10UF K		
C113-116			CK73FB1HXXXK	CHIP C		
C117			CE04EW1A101M	ELECTRO 100UF 10WV		
C118			CK73EB1E104K	CHIP C 0.10UF K		
C119,120			CK73FF1E104Z	CHIP C 0.1UF Z		
C121			CC73FCH1H120J	CHIP C 12PF J		
C122			CK73EB1E104K	CHIP C 0.10UF K		
C123			CK73FF1E104Z	CHIP C 0.1UF Z		
C124			C90-2086-05	ELECTRO 22UF 20WV		
C125			CK73FF1E104Z	CHIP C 0.1UF Z		
C126			CE04EW1A101M	ELECTRO 100UF 10WV		
C127			CK73FB1E103K	CHIP C 0.01UF K		
C128-130			CK73FF1E104Z	CHIP C 0.1UF Z		
C131			CE04EW1A101M	ELECTRO 100UF 10WV		
C132			CK73FF1E104Z	CHIP C 0.1UF Z		
C133			CK73FB1H102K	CHIP C 1000PF K		
C134-137			CK73FB1EXXXK	CHIP C		
C138,140			CK73FF1E104Z	CHIP C 0.1UF Z		
C141			CK73FB1E103K	CHIP C 0.01UF K		
C142			CC73FCH1H270J	CHIP C 27PF J		
C143			CK73EB1E103K	CHIP C 0.01UF K		
C144			CK73FB1E104K	CHIP C 0.10UF K		
C145			CE04EW1C470M	ELECTRO 47UF 16WV		
C147			CE04EW1A101M	ELECTRO 100UF 10WV		
C148,149			CK73FF1E104Z	CHIP C 0.1UF Z		
C150			CE04EW1A101M	ELECTRO 100UF 10WV		
C151-153			CK73FB1EXXXK	CHIP C		
C154			C90-2044-05	ELECTRO 1UF 25WV		
C155			CE04EW1H010M	ELECTRO 1.0UF 50WV		
C156			CK73EB1E104K	CHIP C 0.10UF K		
C157,158			CE04EW1A101M	ELECTRO 100UF 10WV		
C159,160			CE04EW1H010M	ELECTRO 1.0UF 50WV		
C161			CK73EB1E104K	CHIP C 0.10UF K		
C162			CE04EW1A101M	ELECTRO 100UF 10WV		
C163,164			CE04EW1H010M	ELECTRO 1.0UF 50WV		
C167			C90-2153-05	ELECTRO 470UF 10WV		
C168			CC73FSL1H471J	CHIP C 47PF J		
C169,170			CK73FB1E104K	CHIP C 0.10UF K		
C171			CE04EW1A101M	ELECTRO 100UF 10WV		
C172			CK73FB1E104K	CHIP C 0.1UF K		
C173			CK73FB1H102K	CHIP C 0.001UF K		
C174,175			CE04EW1H010M	ELECTRO 1.0UF 50WV		
C176			CK73FB1H102K	CHIP C 1000PF K		
C177			CK45B1H102K	CERAMIC 0.001 K		
C178-181			CK73FB1EXXXK	CHIP C		

E: Scandinavia & Europe K: USA P: Canada W: Europe

U: PX(Far East, Hawaii) T: England M: Other Areas

UE: AAFES(Europe) X: Australia

 indicates safety critical components.

# TS-850S

## PARTS LIST

× New Parts

Parts without Parts No. are not supplied.

Les articles non mentionnes dans le Parts No. ne sont pas fournis.

Telle ohne Parts No. werden nicht geliefert.

IF UNIT (X48-3080-00)

Ref. No. 参照番号	Address 位置	New Parts 新	Parts No. 部品番号	Description 部品名 / 規格	Desti- nation 仕向	Re- marks 備考
C182			CE04EW1A471M	ELECTRØ 470UF 10WV		
C183			CK73FB1E103K	CHIP C 0.01UF K		
C184			CE04EW1C101M	ELECTRØ 100UF 16WV		
C185			CK73FF1E104Z	CHIP C 0.1UF Z		
C186			CK73FB1E103K	CHIP C 0.01UF K		
C187		*	C90-2153-05	ELECTRØ CAPACITØR(AL)		
C188			CK73FB1H102K	CHIP C 1000PF K		
C189			CC73FCH1H101J	CHIP C 100PF J		
C191-193			CK73FB1EXXXX	CHIP C		
C194, 195			CE04EW1A101M	ELECTRØ 100UF 10WV		
C196			CE04EW1C100M	ELECTRØ 10UF 16WV		
C197, 198			CK73EF1C105Z	CHIP C 1.0UF Z		
C199			CE04EW1A101M	ELECTRØ 100UF 10WV		
C200			C92-0502-05	CHIP TAN 0.33UF 35WV		
C201			CE04EW1C100M	ELECTRØ 10UF 16WV		
C202			CE04EW1H2R2M	ELECTRØ 2.2UF 50WV		
C203			CE04EW1C100M	ELECTRØ 10UF 16WV		
C204			CE04EW1H010M	ELECTRØ 1.0UF 50WV		
C205			CE04EW1A101M	ELECTRØ 100UF 10WV		
C206			CK73FB1H102K	CHIP C 1000PF K		
C207			CK73EF1C105Z	CHIP C 1.0UF Z		
C208, 209			CK73FF1E104Z	CHIP C 0.1UF Z		
C210			CE04EW1A470M	ELECTRØ 47UF 10WV		
C211-218			CK73FB1HXXXX	CHIP C		
C219			CK73FB1E103K	CHIP C 0.01UF K		
C220			CK73FF1E104Z	CHIP C 0.1UF Z		
C221, 222			CC73FCH1H101J	CHIP C 100PF J		
C223			CK73FF1E104Z	CHIP C 0.1UF Z		
C225			CE04EW1A101M	ELECTRØ 100UF 10WV		
C226			CE04EW1C470M	ELECTRØ 47UF 16WV		
C227			CE04EW1H2R2M	ELECTRØ 2.2UF 50WV		
C228			CK73FB1E103K	CHIP C 0.01UF K		
C229			CE04EW1H010M	ELECTRØ 1.0UF 50WV		
C230			CE04EW1A470M	ELECTRØ 47UF 10WV		
C231-232			CK73FB1EXXXX	CHIP C		
C233			CK73FF1E104Z	CHIP C 0.1UF Z		
C234-236			CC73FSL1HXXXJ	CHIP C		
CN1		*	E40-5469-05	PIN CONNECTØR(12P)		
CN2		*	E40-5473-05	PIN CONNECTØR(29P)		
CN3		*	E40-5472-05	PIN CONNECTØR(28P)		
CN4		*	E40-5474-05	PIN CONNECTØR(30P)		
CN5 -7			E04-0154-05	RF COAXIAL CABLE RECEPTACLE		
CN8 ,9			E40-3237-05	PIN CONNECTØR(2P)		
CN10		*	E40-5488-05	PIN CONNECTØR(2P)		
CN11			E40-3239-05	PIN CONNECTØR(4P)		
CN12			E40-3237-05	PIN CONNECTØR(2P)		
CN13		*	E40-5490-05	PIN CONNECTØR(3P)		
CN14		*	E40-5488-05	PIN CONNECTØR(2P)		
CN15		*	E40-3237-05	PIN CONNECTØR(2P)		
CN16		*	E40-5489-05	PIN CONNECTØR(2P)		
CN17			E40-3238-05	PIN CONNECTØR(3P)		
CN18			E40-3240-05	PIN CONNECTØR(5P)		
CN19			E40-3243-05	PIN CONNECTØR(8P)		
CN20			E40-3241-05	PIN CONNECTØR(6P)		

E: Scandinavia & Europe K: USA P: Canada W: Europe

U: PX(Far East, Hawaii) T: England M: Other Areas

UE: AAFES(Europe) X: Australia

△ indicates safety critical components.

# TS-850S

## PARTS LIST

× New Parts

Parts without Parts No. are not supplied.

Les articles non mentionnes dans le Parts No. ne sont pas fournis.

Teile ohne Parts No. werden nicht geliefert.

IF UNIT (X48-3080-00)

Ref. No. 参照番号	Address 位置	New Parts 新	Parts No. 部品番号	Description 部品名 / 規格	Desti- nation 仕向	Re- marks 備考
CN21		*	E40-5489-05	PIN CONNECTOR(2P)		
CN22			E40-3241-05	PIN CONNECTOR(6P)		
CN23			E40-3240-05	PIN CONNECTOR(5P)		
CN24, 25			E40-5059-05	PIN CONNECTOR(5P)		
CN101		*	E40-5466-05	PIN CONNECTOR(5P)		
CN201			E40-5209-05	PIN CONNECTOR(6P)		
CN301			E40-5209-05	PIN CONNECTOR(6P)		
CN401		*	E40-5468-05	PIN CONNECTOR(11P)		
J1			E06-1352-05	CYLINDRICAL RECEPTACLE(J1)		
J2			E11-0414-05	PHONE JACK(EX.SP)		
J3			E11-0438-05	PHONE JACK(KEY)		
TP1 ,2			E23-0465-05	TERMINAL(RFGV)		
A1			F01-0982-04	HEAT SINK(AF AMP)		
A2	3F		G02-0574-04	SPRING		
A3 ,4			J32-0761-04	STUD(PCB)		
CF1			L72-0333-05	CERAMIC FILTER(2.7K)		
CF2			L72-0315-05	CERAMIC FILTER(12K)		
CF3			L72-0319-05	CERAMIC FILTER(6K)		
L1			L34-0943-05	COIL(8.83)		
L2		*	L34-4255-05	COIL(455)		
L3		*	L34-4256-05	COIL(455)		
L4 -6		*	L34-4254-05	COIL(8.83)		
L7 ,8		*	L34-4255-05	COIL(455)		
L9 ,10			L40-1021-14	SMALL FIXED INDUCTOR(1MH)		
L11 -14			L33-0712-05	SMALL FIXED INDUCTOR(6.8MH)		
L16		*	L34-4258-05	COIL(NOTCH)		
L17			L34-0540-05	COIL(455)		
L18 ,19		*	L34-4255-05	COIL(455)		
L20			L40-1021-14	SMALL FIXED INDUCTOR(1MH)		
L21		*	L34-4257-05	COIL(455)		
L22 -24			L40-1021-14	SMALL FIXED INDUCTOR(1MH)		
L25 ,26			L40-2211-48	SMALL FIXED INDUCTOR(220UH)		
L29			L40-1021-14	SMALL FIXED INDUCTOR(1MH)		
L30 -32			L40-2211-48	SMALL FIXED INDUCTOR(220UH)		
L33		*	L34-4253-05	COIL(HIBST)		
L34			L40-2211-48	SMALL FIXED INDUCTOR(220UH)		
L35 ,36			L40-1021-14	SMALL FIXED INDUCTOR(1MH)		
L37			L40-1092-13	SMALL FIXED INDUCTOR(1UH)		
L38			L40-1021-14	SMALL FIXED INDUCTOR(1MH)		
A5 ,6			N30-3010-46	PAN HEAD MACHINE SCREW		
R1 -203			RK73FB2AXXXJ	CHIP R		
R204			RD14BB2C474J	CHIP R 470K J		
R205-328			RK73FB2AXXXJ	CHIP R		
VR1			R05-0402-05	POTENTIOMETER 300 (ANTI)		
VR2			R05-3443-05	TRIM POT. 10K		
VR3			R05-5401-05	POTENTIOMETER 100K(DELAY)		
VR4 ,5		*	R12-6744-05	TRIMMING POT.47K (BEEP)		
VR6			R12-6423-05	TRIM POT. 10K		
VR7		*	R12-6413-05	TRIMMING POT.220 (DT1F)		
VR8			R12-6423-05	TRIM POT. 10K		
VR9			R12-6421-05	TRIM POT. 4.7K		

E: Scandinavia & Europe K: USA P: Canada W: Europe

U: PX(Far East, Hawaii) T: England M: Other Areas

UE: AAFES(Europe) X: Australia

⚠ indicates safety critical components.

# TS-850S

## PARTS LIST

\* New Parts

Parts without Parts No. are not supplied.

Les articles non mentionnés dans le Parts No. ne sont pas fournis.

Teile ohne Parts No. werden nicht geliefert.

IF UNIT (X48-3080-00)

Ref. No. 参照番号	Address 位置	New Parts 新	Parts No. 部品番号	Description 部品名 / 規格	Desti- nation 仕向	Re- marks 備考
VR10			R12-6427-05	TRIM POT. 47K		
VR11			R12-6421-05	TRIM POT. 4.7K		
VR12-14			R12-6423-05	TRIM POT. 10K		
VR15			R12-6425-05	TRIM POT. 22K		
VR16		*	R12-6742-05	TRIMMING POT. 22K (NOTCH)		
VR17			R12-6423-05	TRIM POT. 10K		
VR18			R12-6740-05	TRIMMING POT. 10K (DATA)		
W7 -9			R92-0670-05	CHIP R U OHM		
W10 -12			R92-0679-05	CHIP R U OHM		
W13			R92-0670-05	CHIP R U OHM		
W18 -19			R92-0670-05	CHIP R U OHM		
W20 -22			R92-0679-05	CHIP R U OHM		
W23			R92-0670-05	CHIP R U OHM		
W24 -26			R92-0679-05	CHIP R U OHM		
W27			R92-0670-05	CHIP R U OHM		
W29 -34			R92-0670-05	CHIP R U OHM		
W35			R92-0679-05	CHIP R U OHM		
W36 -38			R92-0670-05	CHIP R U OHM		
W40 ,41			R92-0670-05	CHIP R U OHM		
W43 -45			R92-0670-05	CHIP R U OHM		
W45			R92-0670-05	CHIP R U OHM		
W46			R92-0679-05	CHIP R U OHM		
W47 -49			R92-0670-05	CHIP R U OHM		
W51			R92-0670-05	CHIP R U OHM		
W53			R92-0670-05	CHIP R U OHM		
W57			R92-0670-05	CHIP R U OHM		
W57			R92-0670-05	CHIP R U OHM		
W59			R92-0679-05	CHIP R U OHM		
W61			R92-0679-05	CHIP R U OHM		
W63			R92-0670-05	CHIP R U OHM		
W65			R92-0670-05	CHIP R U OHM		
W67			R92-0670-05	CHIP R U OHM		
W69			R92-0679-05	CHIP R U OHM		
W71			R92-0670-05	CHIP R U OHM		
W75			R92-0670-05	CHIP R U OHM		
W77			R92-0670-05	CHIP R U OHM		
W81			R92-0670-05	CHIP R U OHM		
W100			R92-0670-05	CHIP R U OHM		
W101			R92-0679-05	CHIP R U OHM		
W103			R92-0670-05	CHIP R U OHM		
W253			R92-0670-05	CHIP R U OHM		
S1			S31-2419-05	SLIDE SWITCH(ELECTRIC KEY)		
S101, 102			S40-2440-15	PUSH SWITCH(SEND)		
S103			S40-2441-15	PUSH SWITCH(TUNE)		
S201, 202			S40-2440-15	PUSH SWITCH(SEND)		
S203			S40-2441-15	PUSH SWITCH(TUNE)		
S204, 205			S40-2440-15	PUSH SWITCH(SEND)		
S301-304			S40-2440-15	PUSH SWITCH(SEND)		
S401, 402			S40-2441-15	PUSH SWITCH(TUNE)		
S403-405			S40-2440-15	PUSH SWITCH(SEND)		
D1			DAN235K	DIODE		
D2 -19			RLS135	DIODE		
D20		*	1SV147	DIODE		
D23			DAN202K	DIODE		

E: Scandinavia & Europe K: USA P: Canada W: Europe

U: PX(Far East, Hawaii) T: England M: Other Areas

UE: AAFES(Europe) X: Australia

△ indicates safety critical components.

# TS-850S

## PARTS LIST

× New Parts

Parts without Parts No. are not supplied.

Les articles non mentionnés dans le Parts No. ne sont pas fournis.

Teile ohne Parts No. werden nicht geliefert.

IF UNIT (X48-3080-00)

Ref. No. 参照番号	Address 位置	New Parts 新	Parts No. 部品番号	Description 部品名 / 規格	Desti- nation 仕向	Re- marks 備考
D24			HSM88AS	DIODE		
D27			RLS73	DIODE		
D28			MI204	DIODE		
D29 ,30			DAN202K	DIODE		
D31			HSM88AS	DIODE		
D32			1N60	DIODE		
D33 -41			DAN202K	DIODE		
D42 ,43			RLS73	DIODE		
D44			DAN202K	DIODE		
D46			DAN235K	DIODE		
D47			RLS73	DIODE		
D48			HSM88AS	DIODE		
D49			DAN202K	DIODE		
D50 -52			RLS73	DIODE		
D53			DAN202K	DIODE		
D54 ,55			RLS73	DIODE		
D57			RLS135	DIODE		
D58			RLS73	DIODE		
D59			RLZJ5.1B	DIODE		
D60 -62			RLS73	DIODE		
D63		*	RLZJ6.2A	DIODE		
D64 ,65			1SS133	DIODE		
IC1			TA7302P	IC(FM IF)		
IC2			MC3357P	IC(LOW POWER FM IF)		
IC3			AN612	IC(BALANCE MODULATOR)		
IC4			UPC1037HA	IC(DUBBLE BALANCE MODULATOR)		
IC5			TA7324P	IC(OP AMP)		
IC6			UPC2002V	IC(OP AMP X2)		
IC7			NJM2904M	IC(OP AMP X2)		
IC8			NJM4558M	IC(OP AMP X2)		
IC9 -12			TC4066BF	IC(BILATERAL SWITCH X4)		
Q1 ,2			3SK131(M)	FET		
Q3			DTC124EK	DIGITAL TRANSISTOR		
Q4			3SK131(M)	FET		
Q5			2SC2712(Y)	TRANSISTOR		
Q6 -8			3SK131(M)	FET		
Q9 -13			2SC2712(Y)	TRANSISTOR		
Q14 ,15			3SK131(M)	FET		
Q16 -19			2SC2712(Y)	TRANSISTOR		
Q20			2SK210(GR)	FET		
Q21			2SA1162(Y)	TRANSISTOR		
Q22 -25			2SC2712(Y)	TRANSISTOR		
Q26			2SC3324(G)	TRANSISTOR		
Q27			2SC2712(Y)	TRANSISTOR		
Q28			2SD1757K	TRANSISTOR		
Q29 -31			2SC2712(Y)	TRANSISTOR		
Q32			2SC3324(G)	TRANSISTOR		
Q32			2SC3324(K)	TRANSISTOR		
Q33			2SC3722K(R)	TRANSISTOR		
Q33			2SC3324(G)	TRANSISTOR		
Q34			2SA1162(Y)	TRANSISTOR		
Q35			DTC124EK	DIGITAL TRANSISTOR		
Q36 ,37			FMC2	DIGITAL TRANSISTOR		
Q38			DTA124EK	DIGITAL TRANSISTOR		
Q39 -41			FMC2	DIGITAL TRANSISTOR		

E: Scandinavia & Europe K: USA P: Canada W: Europe

U: PX(Far East, Hawaii) T: England M: Other Areas

UE: AAFES(Europe) X: Australia

▲ indicates safety critical components.

# TS-850S

## PARTS LIST

× New Parts

Parts without Parts No. are not supplied.

Les articles non mentionnés dans le Parts No. ne sont pas fournis.

Telle ohne Parts No. werden nicht geliefert.

IF UNIT (X48-3080-00)

PLL UNIT (X50-3130-00)

Ref. No. 参照番号	Address 位置	New Parts 新	Parts No. 部品番号	Description 部品名 / 規格	Desti- nation 仕向	Re- marks 備考
Q42			FMG1	DIGITAL TRANSISTOR		
Q43			DTC124EK	DIGITAL TRANSISTOR		
Q44			FMG1	DIGITAL TRANSISTOR		
Q45 ,46			FMA1	TRANSISTOR		
Q47 -51			DTA124EK	DIGITAL TRANSISTOR		
Q52			2SA1162(Y)	TRANSISTOR		
Q53 -69			DTC124EK	DIGITAL TRANSISTOR		
Q70			2SC2712(Y)	TRANSISTOR		
Q71 ,72			DTC124EK	DIGITAL TRANSISTOR		
Q73			DTA124EK	DIGITAL TRANSISTOR		
Q74			DTC114EK	DIGITAL TRANSISTOR		
Q75			DTC124EK	DIGITAL TRANSISTOR		
Q76			2SK210(GR)	FET		
Q77			DTC114EK	DIGITAL TRANSISTOR		
Q78			DTC114WK	DIGITAL TRANSISTOR		
TH1		*	157-502-53002	THERMISTOR 5K		
TH2		*	157-501-53009	THERMISTOR 500		
TH3		*	157-502-53002	THERMISTOR 5K		
TH4		*	157-503-53006	THERMISTOR 50K		
TH5		*	157-203-53004	THERMISTOR 20K		
Z5			X59-1080-00	MODULE UNIT(VOX)		
Z4		*	X59-3680-01	MODULE UNIT(TRX)		
Z10		*	X59-3820-00	MODULE UNIT(AGC)		
Z9		*	X59-3830-00	MODULE UNIT(SM-AMP)		
Z7		*	X59-3840-00	MODULE UNIT(MIC-SW)		
Z1		*	X59-3850-00	MODULE UNIT(MIC-AMP)		
Z3		*	X59-3860-00	MODULE UNIT(DELAY)		
Z6		*	X59-3870-00	MODULE UNIT(BK-IN)		
Z2		*	X59-3880-00	MODULE UNIT(BK-SW)		
Z8		*	X59-3890-00	MODULE UNIT(PROC)		
<b>PLL UNIT (X50-3130-00)</b>						
C1			CK73FB1H102K	CHIP C 1000PF K		
C2 -6			CC73FCH1HXXXJ	CHIP C		
C7 ,8			CK73FB1H102K	CHIP C 1000PF K		
C9 -13			CC73FCH1HXXXJ	CHIP C		
C14 ,15			CK73FB1H102K	CHIP C 1000PF K		
C16			CC73FCH1H390J	CHIP C 39PF J		
C17			CC73FSL1H1000	CHIP C 10PF J		
C18 -20			CC73FCH1HXXXJ	CHIP C		
C21 ,22			CK73FB1H102K	CHIP C 1000PF K		
C23 -27			CC73FCH1HXXXJ	CHIP C		
C28			CK73FB1H102K	CHIP C 1000PF K		
C29 ,30			C91-0119-05	CERAMIC 0.047UF K		
C31 -38			CK73FB1H102K	CHIP C 1000PF K		
C39 -49			CC73FSL1H101J	CHIP C 100PF J		
C50			CC73FCH1H101J	CHIP C 100PF J		
C52			CC73FSL1H181J	CHIP C 180PF J		
C53 -58			CK73FB1E103K	CHIP C 0.01UF K		
C59			CK73FB1H102K	CHIP C 1000PF K		
C60			CC73FCH1HOR5C	CHIP C 0.5PF C		
C61			CK73FB1E103K	CHIP C 0.01UF K		
C62			C90-2022-05	OS 22UF 16WV		
C63			CK73FB1E103K	CHIP C 0.01UF K		
C65			CE04EW1C471M	ELECTRO 470UF 16WV		
C66 -70			CK73FB1H102K	CHIP C 1000PF K		

E: Scandinavia & Europe K: USA P: Canada W: Europe

U: PX(Far East, Hawaii) T: England M: Other Areas

UE: AAFES(Europe) X: Australia

⚠ indicates safety critical components.

# TS-850S

## PARTS LIST

× New Parts

Parts without Parts No. are not supplied.

Les articles non mentionnés dans le Parts No. ne sont pas fournis.

Telle ohne Parts No. werden nicht geliefert.

PLL UNIT (X50-3130-00)

Ref. No. 参照番号	Address 位置	New Parts 新	Parts No. 部品番号	Description 部品名 / 規格	Desti- nation 仕 向	Re- marks 備考
C71			CK73FB1E103K	CHIP C 0.01UF K		
C72			CE04EW1C470M	ELECTRØ 47UF 16WV		
C73			CK73FB1E103K	CHIP C 0.01UF K		
C74			CE04EW1C101M	ELECTRØ 100UF 16WV		
C75			CK73FB1E103K	CHIP C 0.01UF K		
C76			CQ92M1H103K	MYLAR 0.010UF K		
C77			C91-1083-05	FILM 0.47UF 63WV		
C78			CK73FB1H102K	CHIP C 1000PF K		
C79 -83			CC73FCH1HXXXD	CHIP C		
C84			CK73FB1E103K	CHIP C 0.01UF K		
C85			CC73FCH1H240J	CHIP C 24PF J		
C86 -89			CK73FB1H102K	CHIP C 1000PF K		
C90			CK73FB1E103K	CHIP C 0.01UF K		
C91 ,92			CK73FB1H102K	CHIP C 1000PF K		
C93 -97			CK73FB1E103K	CHIP C 0.01UF K		
C98 -99			CC73FCH1HXXXJ	CHIP C		
C100			CK73FB1H102K	CHIP C 1000PF K		
C101			CC73FCH1H680J	CHIP C 68PF J		
C102			CK73FB1H102K	CHIP C 1000PF K		
C103-110			CC73FCH1HXXXD	CHIP C		
C111			CK73FB1E103K	CHIP C 0.01UF K		
C112-115			CK73FB1HXXXK	CHIP C		
C116			CE04EW1C470M	ELECTRØ 47UF 16WV		
C117			CK73FB1E103K	CHIP C 0.01UF K		
C118			CK73FB1H102K	CHIP C 1000PF K		
C119			CK73FB1E103K	CHIP C 0.01UF K		
C120			CE04EW1C470M	ELECTRØ 47UF 16WV		
C121			CK73FB1H102K	CHIP C 1000PF K		
C122			CK73FB1E103K	CHIP C 0.01UF K		
C123			CE04EW1C101M	ELECTRØ 100UF 16WV		
C124			CK73FB1H102K	CHIP C 1000PF K		
C125			CQ92M1H333K	MYLAR 0.033UF K		
C126			C91-1101-05	FILM 0.22UF 63WV		
C127			CE04EW1H4R7M	ELECTRØ 4.7UF 50WV		
C128			CK73FB1H102K	CHIP C 1000PF K		
C129			CE04EW1C101M	ELECTRØ 100UF 16WV		
C130			CK73FB1H102K	CHIP C 1000PF K		
C131			CK73FB1E103K	CHIP C 0.01UF K		
C132			CK73FB1H102K	CHIP C 1000PF K		
C134			CC73FUJ1H270J	CHIP C 27PF J		
C135-136			CC73FRH1HXXXJ	CHIP C		
C137			CK73FB1E103K	CHIP C 0.01UF K		
C138, 139			CC73FCH1H050C	CHIP C 5PF C		
C140			CK73FB1H103K	CHIP C 0.010UF K		
C141			CE04EW1C470M	ELECTRØ 47UF 16WV		
C142, 143			CK73FB1E103K	CHIP C 0.01UF K		
C144, 145			CK73FB1H102K	CHIP C 1000PF K		
C146			CC73FSL1H221J	CHIP C 220PF J		
C147			CK73FB1E103K	CHIP C 0.01UF K		
C148			CC73FCH1HOR5C	CHIP C 0.5PF C		
C149, 150			CK73FB1H102K	CHIP C 1000PF K		
C151, 152			CC73FCH1H330J	CHIP C 33PF J		
C153			CC73FUJ1H270J	CHIP C 27PF J		
C154			CK73FB1E103K	CHIP C 0.01UF K		
C155			CE04EW1C470M	ELECTRØ 47UF 16WV		

E: Scandinavia & Europe K: USA P: Canada W: Europe

U: PX(Far East, Hawaii) T: England M: Other Areas

UE: AAFES(Europe) X: Australia

⚠ indicates safety critical components.

# TS-850S

## PARTS LIST

\* New Parts

Parts without Parts No. are not supplied.

Les articles non mentionnés dans le Parts No. ne sont pas fournis.

Telle ohne Parts No. werden nicht geliefert.

PLL UNIT (X50-3130-00)

Ref. No. 参照番号	Address 位置	New Parts 新	Parts No. 部品番号	Description 部品名 / 規格	Desti- nation 仕向	Re- marks 備考
C156, 157 C158-159 C160 C161, 162 C163-168			CK73FB1E103K CK73FB1HXXXK CK73BF1E474Z CK73FB1E103K CC73FCH1HXXXJ	CHIP C 0.01UF K CHIP C CHIP C 0.47UF Z CHIP C 0.01UF K CHIP C		
C169 C170, 171 C172-173 C174, 175 C176-182			CK73FF1E104Z CK73FB1H102K CC73FCH1HXXXD CK73FB1H102K CK73FB1EXXXK	CHIP C 0.1UF Z CHIP C 1000PF K CHIP C CHIP C 1000PF K CHIP C		
TC1 ,2 TC3 ,4 TC5		*	C05-0375-05 C05-0374-05 C05-0044-05	TRIMMING CAP 10PF TRIMMING CAP 6PF TRIM CAP 30PF		
CN1 ,2 CN3 CN4 CN5 ,6 CN7		*	E04-0154-05 E40-5469-05 E40-5386-05 E04-0154-05 E40-3238-05	RF COAXIAL CABLE RECEPTACLE PIN CONNECTOR(12P) PIN CONNECTOR(24P) RF COAXIAL CABLE RECEPTACLE PIN CONNECTOR(3P)		
CN8 ,9 TP1 -5			E40-3237-05 E23-0512-05  F11-1140-04 F11-1141-04	PIN CONNECTOR(2P) TERMINAL  SHIELDING CASE SHIELDING COVER		
L1 L2 L3 L4 L5			L33-0664-05 L34-2354-05 L40-4791-19 L33-0664-05 L34-2354-05	CHOKER COIL(2.7UH) COIL SMALL FIXED INDUCTOR(4.7UH) CHOKER COIL(2.7UH) COIL		
L6 L7 L8 L9 L10			L40-4791-19 L33-0664-05 L34-2354-05 L40-4791-19 L33-0664-05	SMALL FIXED INDUCTOR(4.7UH) CHOKER COIL(2.7UH) COIL SMALL FIXED INDUCTOR(4.7UH) CHOKER COIL(2.7UH)		
L11 L12 L13 L14 L15 ,16			L34-2354-05 L40-4791-19 L40-1011-17 L40-1001-12 L40-1001-17	COIL SMALL FIXED INDUCTOR(4.7UH) SMALL FIXED INDUCTOR(100UH) SMALL FIXED INDUCTOR(10UH) SMALL FIXED INDUCTOR(10UH)		
L17 L18 L19 L20 L21			L40-1001-12 L40-1011-17 L34-4222-05 L34-4029-05 L34-4222-05	SMALL FIXED INDUCTOR(10UH) SMALL FIXED INDUCTOR(100UH) COIL COIL COIL		
L22 L23 L24 L25 L26			L40-3382-19 L40-1292-48 L40-3382-19 L40-1592-17 L40-1892-17	SMALL FIXED INDUCTOR SMALL FIXED INDUCTOR(1.2UH) SMALL FIXED INDUCTOR SMALL FIXED INDUCTOR(1.5UH) SMALL FIXED INDUCTOR(1.8UH)		
L27 ,28 L29 L30 -33 L34 ,35 L36			L40-3991-17 L40-2282-19 L40-1011-17 L34-4222-05 L40-1592-17	SMALL FIXED INDUCTOR(3.9UH) SMALL FIXED INDUCTOR(.22UH) SMALL FIXED INDUCTOR(100UH) COIL SMALL FIXED INDUCTOR(1.5UH)		
L38			L40-1011-17	SMALL FIXED INDUCTOR(100UH)		

E: Scandinavia & Europe K: USA P: Canada W: Europe

U: PX(Far East, Hawaii) T: England M: Other Areas

UE: AAFES(Europe) X: Australia

 indicates safety critical components.



# TS-850S

## PARTS LIST

× New Parts

Parts without Parts No. are not supplied.

Les articles non mentionnés dans le Parts No. ne sont pas fournis.

Telle ohne Parts No. werden nicht geliefert.

PLL UNIT (X50-3130-00)

CAR UNIT (X50-3140-00)

Ref. No. 参照番号	Address 位置	New Parts 新	Parts No. 部品番号	Description 部品名 / 規格	Desti- nation 仕向	Re- marks 備考
L39 L40 L41 X1			L40-5691-17 L40-1011-17 L40-2282-48 L77-0963-05	SMALL FIXED INDUCTOR(5.6UH) SMALL FIXED INDUCTOR(100UH) SMALL FIXED INDUCTOR(.22UH) CRYSTAL RESONATOR(20MHZ)		
V			N30-2604-41	PAN HEAD MACHINE SCREW		
R1 -126 W1 ,2 W3			RK73FB2AXXXJ R92-0150-05 R92-0670-05	CHIP R JUMPER REST 0 0HM CHIP R 0 0HM		
D1 D2 D3 D4 D5			1SV166 RLS73 1SV166 RLS73 1SV166	DIODE DIODE DIODE DIODE DIODE		
D6 D7 D8 D9 IC1			RLS73 1SV166 RLS73 DAN202(K) SN16913P	DIODE DIODE DIODE DIODE IC(DUBLE BALANCED MIXERS)		
IC2 IC3 ,4 IC5 IC6 IC7 ,8		*	TA78DL09P CXD1225M AN78N05 SN76514N UPD74HC390G	IC IC(PLL SYNTHESIZER) IC(VOLTAGE REGULATOR/ +5V) IC(MIXER) IC		
Q1 -4 Q5 -8 Q9 -11 Q12 ,13 Q14			2SK210(GR) DTC114EK 2SC3324(G) 2SC2714(Y) 2SC2996(O)	FET DIGITAL TRANSISTOR TRANSISTOR TRANSISTOR TRANSISTOR		
Q14 Q15 Q16 Q17 Q18 -20			2SC2996(Y) 2SC2712(Y) 2SC2714(Y) 2SC2954(QK) 2SC3324(G)	TRANSISTOR TRANSISTOR TRANSISTOR TRANSISTOR TRANSISTOR		
Q21 ,22 Q23 Q24 ,25 Q26 Q27			2SC2714(Y) 2SC2712(Y) 2SC2714(Y) 2SC2712(Y) DTC114TK	TRANSISTOR TRANSISTOR TRANSISTOR TRANSISTOR DIGITAL TRANSISTOR		
Q28			DTA114EK	DIGITAL TRANSISTOR		
Z1			X58-3390-03	SUB UNIT(VCO2 64.22MHZ)		
<b>CAR UNIT (X50-3140-00)</b>						
C1 C2 ,3 C4 C5 -7 C8			C92-0040-05 CK73FB1H103K C92-0037-05 CK73FB1HXXXX C92-0037-05	ELECTRO 47UF 16WV CHIP C 0.010UF K ELECTRO 10UF 16WV CHIP C ELECTRO 10UF 16WV		
C9 C10 C11 ,12 C13 C14			CK73FB1H103K C92-0037-05 CK73FB1H103K C92-0037-05 CK73FB1H103K	CHIP C 0.010UF K ELECTRO 10UF 16WV CHIP C 0.010UF K ELECTRO 10UF 16WV CHIP C 0.010UF K		
C15			C92-0037-05	ELECTRO 10UF 16WV		

E: Scandinavia & Europe K: USA P: Canada W: Europe

U: PX(Far East, Hawaii) T: England M: Other Areas

UE: AAFES(Europe) X: Australia

 indicates safety critical components.

# TS-850S

## PARTS LIST

× New Parts

Parts without Parts No. are not supplied.

Les articles non mentionnés dans le Parts No. ne sont pas fournis.

Telle ohne Parts No. werden nicht geliefert.

CAR UNIT (X50-3140-00)

Ref. No. 参照番号	Address 位置	New Parts 新	Parts No. 部品番号	Description 部品名 / 規格	Desti- nation 仕向	Re- marks 備考
C16 -19			CK73FB1HXXXK	CHIP C		
C20			C92-0037-05	ELECTRØ	10UF 16WV	
C21			CK73FB1H103K	CHIP C	0.010UF K	
C22			C92-0037-05	ELECTRØ	10UF 16WV	
C23 ,24			CK73FB1H103K	CHIP C	0.010UF K	
C25			C92-0037-05	ELECTRØ	10UF 16WV	
C26			CK73FB1H103K	CHIP C	0.010UF K	
C27			C92-0037-05	ELECTRØ	10UF 16WV	
C28			CK73FB1H103K	CHIP C	0.010UF K	
C30 -31			CC73FCH1HXXXJ	CHIP C		
C32			CK73FB1H103K	CHIP C	0.010UF K	
C33			C92-0516-05	TANTAL	4.7UF 16WV	
C34			CK73FB1H103K	CHIP C	0.010UF K	
C35 -37			CC73FCH1HXXXJ	CHIP C		
C38 -43			CK73FB1H103K	CHIP C	0.010UF K	
C44 -58			CC73FCH1HXXXJ	CHIP C		
C59 -65			CK73FB1H103K	CHIP C	0.010UF K	
C66			C92-0037-05	ELECTRØ	10UF 16WV	
C67 -68			CC73FCH1HXXXJ	CHIP C		
C69			CK73FB1H103K	CHIP C	0.010UF K	
C70			C92-0516-05	TANTAL	4.7UF 16WV	
C71			CK73FB1H103K	CHIP C	0.010UF K	
C72			CC73FCH1H101J	CHIP C	100PF J	
C73			CK73FB1H103K	CHIP C	0.010UF K	
C74			C92-0516-05	TANTAL	4.7UF 16WV	
C75			CK73FB1H103K	CHIP C	0.010UF K	
C76 -77			CC73FCH1HXXXD	CHIP C		
C78 -80			CK73FB1H103K	CHIP C	0.010UF K	
C81 -84			CC73FCH1HXXXJ	CHIP C		
C85			CK73FB1H103K	CHIP C	0.010UF K	
C86			C92-0516-05	TANTAL	4.7UF 16WV	
C87			CK73FB1H103K	CHIP C	0.010UF K	
C88			CC73FCH1H101J	CHIP C	100PF J	
C89			CK73FB1H103K	CHIP C	0.010UF K	
C90			C92-0516-05	TANTAL	4.7UF 16UF	
C91 -94			CK73FB1H103K	CHIP C	0.010UF K	
C95 -97			CC73FCH1HXXXJ	CHIP C		
C99			CK73FF1E104Z	CHIP C	0.1UF Z	
C100			C92-0003-05	CHIP TAN	1.47UF 25WV	
C101			C92-0004-05	CHIP TAN	1.0UF 16WV	
C102			CC73FCH1H271J	CHIP C	270PF J	
C103			CK73FB1H103K	CHIP C	0.010UF K	
C104			C92-0516-05	TANTAL	4.7UF 16WV	
C105-128			CK73FB1HXXXK	CHIP C		
C129-133			CC73FCH1HXXXJ	CHIP C		
C134			CK73FB1H103K	CHIP C	0.010UF K	
CN1			E40-5154-05	PIN CONNECTOR		
CN2 -5			E04-0157-05	RF COAXIAL CABLE RECEPTACLE		
CN6			E40-3239-05	PIN CONNECTOR		
CN7			E40-3237-05	PIN CONNECTOR		
CF1 ,2			L72-0343-05	CERAMIC FILTER		
CF3 ,4			L72-0351-05	CERAMIC FILTER		
L1			L40-1001-11	SMALL FIXED INDUCTOR		
L2 -10			L40-1001-48	SMALL FIXED INDUCTOR		

E: Scandinavia & Europe K: USA P: Canada W: Europe

U: PX(Far East, Hawaii) T: England M: Other Areas

UE: AAFES(Europe) X: Australia

⚠ indicates safety critical components.

## PARTS LIST

× New Parts

Parts without Parts No. are not supplied.

Les articles non mentionnés dans le Parts No. ne sont pas fournis.

Telle ohne Parts No. werden nicht geliefert.

CAR UNIT (X50-3140-00)

FILTER UNIT (X51-3100-00)

Ref. No. 参照番号	Address 位置	New Parts 新	Parts No. 部品番号	Description 部品名 / 規格	Desti- nation 仕向	Re- marks 備考
L11 ,12			L40-1011-48	SMALL FIXED INDUCTOR		
L13 ,14		*	L40-2701-48	SMALL FIXED INDUCTOR		
L15		*	L40-1801-48	SMALL FIXED INDUCTOR		
L16 ,17		*	L40-2701-48	SMALL FIXED INDUCTOR		
L18		*	L40-2201-48	SMALL FIXED INDUCTOR		
L19		*	L40-1801-48	SMALL FIXED INDUCTOR		
L20			L40-1001-48	SMALL FIXED INDUCTOR		
L21			L40-1092-48	SMALL FIXED INDUCTOR		
L22			L40-1001-48	SMALL FIXED INDUCTOR		
L23			L40-1092-48	SMALL FIXED INDUCTOR		
L24 ,25		*	L40-2201-48	SMALL FIXED INDUCTOR		
L26 -29			L40-2282-48	SMALL FIXED INDUCTOR		
CP1 -8		*	R90-0721-05	MULTI-COMP		
R1 -69			RK73FB2AXXXJ	CHIP R		
W1			R92-0670-05	CHIP R 0 OHM		
IC1 -4		*	YM6631	IC(DDS)		
IC5		*	UPD74HC390G	IC		
IC6			SN16913P	IC(DUBLE BALANCED MIXERS)		
IC7 ,8			AN78N05	IC(VOLTAGE REGULATOR/ +5V)		
IC9			TC7S04F	IC(2CH NAND GATE)		
Q1 -4			2SC2712(Y)	TRANSISTOR		
Q5 ,6			2SK508(K53)	FET		
Q7 -10			2SC2712(Y)	TRANSISTOR		
Q11 ,12			2SK508(K53)	FET		
Q13 -18			2SC2712(Y)	TRANSISTOR		
Q19			DTC114EK	DIGITAL TRANSISTOR		
<b>FILTER UNIT (X51-3100-00)</b>						
C1		*	CC45CH2H030C	CERAMIC 3PF C		
C2 -3			CC73FCH1HXXXJ	CHIP C		
C4 ,5			CK73FF1H473Z	CHIP C 0.047UF Z		
C6 -23			CK73FB1H103K	CHIP C 0.010UF K		
C24			CK73EF1H104Z	CHIP C 0.1UF Z		
C25 -27			CC73FCH1HXXXJ	CHIP C		
C28 -42			CK73FB1HXXXK	CHIP C		
C101			CM93D2H102J	MICA 1000PF J		
C102			CC45SL2H331J	CERAMIC 330PF J		
C103		*	CC45SL2H271J	CERAMIC 270PF J		
C104, 105		*	CM93D2H102J	MICA 1000PF J		
C106		*	CC45SL2H151J	CERAMIC 150PF J		
C107			CM93D2H222J	MICA 2200PF J		
C108			CC45SL2H181J	CERAMIC 180PF J		
C109			CC45SL2H101J	CERAMIC 100PF J		
C110		*	CM93D2H102J	MICA 1000PF J		
C111		*	CM93D2H561J	MICA 560PF J		
C112			CC45SL2H431J	CERAMIC 430PF J		
C113			CC45SL2H331J	CERAMIC 330PF J		
C114, 115			CC45SL2H431J	CERAMIC 430PF J		
C116		*	CC45SL2H271J	CERAMIC 270PF J		
C117, 118			CC45SL2H431J	CERAMIC 430PF J		
C119		*	CC45SL2H181J	CERAMIC 180PF J		
C120			CC45SL2H331J	CERAMIC 330PF J		
C121		*	CC45SL2H820J	CERAMIC 82PF J		
C122			CC45SL2H331J	CERAMIC 330PF J		

E: Scandinavia & Europe K: USA P: Canada W: Europe

U: PX(Far East, Hawaii) T: England M: Other Areas

UE: AAFES(Europe) X: Australia

 indicates safety critical components.

# TS-850S

## PARTS LIST

\* New Parts

Parts without Parts No. are not supplied.

Les articles non mentionnes dans le Parts No. ne sont pas fournis.

Telle ohne Parts No. werden nicht geliefert.

FILTER UNIT (X51-3100-00)

Ref. No. 参照番号	Address 位置	New Parts 新	Parts No. 部品番号	Description 部品名 / 规格	Desti- nation 仕向	Re- marks 備考
C123, 124		*	CC45SL2H820J	CERAMIC 82PF J		
C125			CC45SL2H431J	CERAMIC 430PF J		
C126			CC45SL2H331J	CERAMIC 330PF J		
C127, 128			CC45SL2H270J	CERAMIC 27PF J		
C129, 130			CC45SL2H431J	CERAMIC 430PF J		
C131, 132		*	CC45SL2H560J	CERAMIC 56PF J		
C133		*	CC45SL2H181J	CERAMIC 180PF J		
C134		*	CC45SL2H471J	CERAMIC 470PF J		
C135		*	CC45SL2H560J	CERAMIC 56PF J		
C136			CC45SL2H331J	CERAMIC 330PF J		
C137		*	CC45SL2H221J	CERAMIC 220PF J		
C138			CC45SL2H330J	CERAMIC 33PF J		
C139, 140		*	CC45SL2H151J	CERAMIC 150PF J		
C141			CC45SL2H101J	CERAMIC 100PF J		
C142			CC45SL2H151J	CERAMIC 150PF J		
C143			CC45SL2H121J	CERAMIC 120PF J		
C144			CC45SL2H100D	CERAMIC 10PF D		
C145			CC45SL2H221J	CERAMIC 220PF J		
C146			CC45SL2H470J	CERAMIC 47PF J		
C147			CC45SL2H101J	CERAMIC 100PF J		
C148			CC45SL2H820J	CERAMIC 82PF J		
C149			CC45SL2H100D	CERAMIC 10PF D		
C150			CC45SL2H820J	CERAMIC 82PF J		
C151			CC45SL2H680J	CERAMIC 68PF J		
C152			CC45SL2H330J	CERAMIC 33PF J		
C153			CC45SL2H820J	CERAMIC 82PF J		
TC1			C05-0030-15	TRIM CAP 20PF		
CN1			E04-0157-05	RF COAXIAL CABLE RECEPTACLE		
CN2			E23-0464-05	TEST PIN		
CN3			E40-5154-05	PIN CONNECTOR		
CN4			E40-5068-05	PIN CONNECTOR(11P)		
CN5 , 6			E04-0157-05	RF COAXIAL CABLE RECEPTACLE		
CN7			E40-3238-05	PIN CONNECTOR(3P)		
CN8			E40-3237-05	PIN CONNECTOR(2P)		
CN9			E40-5069-05	PIN CONNECTOR(12P)		
CN10			E40-3243-05	PIN CONNECTOR(8P)		
CN11			E40-3237-05	PIN CONNECTOR(2P)		
CN12-13			E23-0512-05	TERMINAL		
CN14			E23-0464-05	TEST PIN		
CN15			E40-3238-05	PIN CONNECTOR(3P)		
J1			E06-1352-05	CYLINDRICAL RECEPTACLE		
J2			E06-0658-05	CYLINDRICAL RECEPTACLE		
J3		*	E11-0445-05	PHONE JACK(3.5D)		
W1		*	E37-0058-05	CONNECTING WIRE		
W2			E23-0464-05	TEST PIN		
A1			J21-4327-04	MOUNTING HARDWARE		
L1			L39-0480-05	COIL		
L2 , 3			L40-1021-15	SMALL FIXED INDUCTOR		
L4 -11			L40-1011-15	SMALL FIXED INDUCTOR		
L12			L40-1021-12	SMALL FIXED INDUCTOR		
L13 , 14			L34-1035-05	COIL		
L15 -18			L40-2211-14	SMALL FIXED INDUCTOR		
L101		*	L39-0491-05	COIL		

E: Scandinavia & Europe K: USA P: Canada W: Europe

U: PX(Far East, Hawaii) T: England M: Other Areas

UE: AAFES(Europe) X: Australia

▲ indicates safety critical components.

# TS-850S

## PARTS LIST

× New Parts

Parts without Parts No. are not supplied.

Les articles non mentionnés dans le Parts No. ne sont pas fournis.

Teile ohne Parts No. werden nicht geliefert.

FILTER UNIT (X51-3100-00)

AT UNIT (X53-3340-00)

Ref. No. 参照番号	Address 位置	New Parts 新	Parts No. 部品番号	Description 部品名 / 規格	Desti- nation 向	Re- marks 備考
L102		*	L39-0492-05	COIL		
L103		*	L39-0493-05	COIL		
L104			L34-3151-05	FILTER COIL C		
L105			L34-3150-05	FILTER COIL D		
L106			L34-3149-05	FILTER COIL E		
L107			L34-3152-05	FILTER COIL F		
L108, 109			L34-3151-05	FILTER COIL C		
L110			L34-3153-05	COIL		
L111			L34-1279-05	COIL		
L112			L34-1281-05	COIL		
L113			L34-1279-05	COIL		
L114			L34-1280-05	COIL		
L115			L34-1281-05	COIL		
L116			L34-1282-05	COIL		
T1 -8			L92-0107-05	TOROIDAL CORE		
T9 ,10			L92-0108-05	TOROIDAL CORE		
R1 -28			RK73FB2AXXXJ	CHIP R		
VR1			R12-0104-05	TRIM POT. 220		
W2 ,3			R92-0150-05	JUMPER REST 0 OHM		
K1 -14			S51-1420-05	RELAY		
K15			S51-1429-05	RELAY		
D1 ,2			1SS101	DIODE		
D3			RLZJ5.1B	DIODE		
D4 -7			RLS73	DIODE		
D8 -15			LFB01	DIODE		
D16			DSA301LA	DIODE		
D17			V08(G)	DIODE		
D18			RLS245	DIODE		
IC1			SN74LS145N	IC(BCD TO DECIMAL DECODER/DRIV		
IC2			M54581P	IC(TRANSISTOR ARRAY)		
Q1			2SA1162(Y)	TRANSISTOR		
<b>AT UNIT (X53-3340-00)</b>						
C1			CC45SL2H330J	CERAMIC 33PF J		
C2 -8			CK73FB1E103K	CHIP C 0.01UF K		
C9 ,10			CK73FB1H102K	CHIP C 1000PF K		
C11			CK73FB1E103K	CHIP C 0.01UF K		
C12			CE04EW1C470M	ELECTRO 47UF 16WV		
C13 -15			CK73FB1E103K	CHIP C 0.01UF K		
C16			CK73EF1E474Z	CHIP C 0.47UF Z		
C17 -19			CK73FB1E103K	CHIP C 0.01UF K		
C20			CE04EW1C101M	ELECTRO 100UF 16WV		
C21 -23			CK73FB1E103K	CHIP C 0.01UF K		
C24			CK73EF1E474Z	CHIP C 0.47UF Z		
C25			CK73FB1E103K	CHIP C 0.01UF K		
C26			CE04EW1C101M	ELECTRO 100UF 16WV		
C27 -37			CK73FB1EXXXK	CHIP C		
C38 -108			CK73FB1HXXXX	CHIP C		
TC1			C05-0031-15	TRIM CAP 10PF		
VC1 ,2	2H		C02-0023-05	VARIABLE		
A5	3H		D40-0633-15	GEAR ASSY		
CN1 ,2			E04-0157-05	RF COAXIAL CABLE RECEPTACLE		
CN3			E40-3239-05	PIN CONNECTOR(4P)		

E: Scandinavia & Europe K: USA P: Canada W: Europe

U: PX(Far East, Hawaii) T: England M: Other Areas

UE: AAFES(Europe) X: Australia

 indicates safety critical components.

# TS-850S

## PARTS LIST

× New Parts

Parts without Parts No. are not supplied.

Les articles non mentionnés dans le Parts No. ne sont pas fournis.

Telle ohne Parts No. werden nicht geliefert.

AT UNIT (X53-3340-00)

Ref. No. 参照番号	Address 位置	New Parts 新	Parts No. 部品番号	Description 部品名 / 規格	Desti- nation 仕向	Re- marks 備考
CN4 CN5 CN6 CN7 CN101			E40-3240-05 E40-3238-05 E40-3237-05 E40-5068-05 E40-5066-05	PIN CONNECTOR(5P) PIN ASSY(3P) PIN ASSY(2P) PIN ASSY(11P) PIN CONNECTOR(9P)		
W1 -7 W101 W103 W201, 202		*	E33-1933-05 E33-1933-05 E33-1933-05 E33-1933-05	FINISHED WIRE SET FINISHED WIRE SET FINISHED WIRE SET FINISHED WIRE SET		
L1 L2 L3 -6 L7 -11 L12 -14		*	L39-0496-05 L39-0415-15 L40-1011-13 L40-1011-14 L40-1011-13	TOROIDAL COIL TOROIDAL COIL SMALL FIXED INDUCTOR(100UH) SMALL FIXED INDUCTOR(100UH) SMALL FIXED INDUCTOR(100UH)		
L101-103 L105-108 L109 L110 L111		*	L40-1011-14 L40-1011-14 L34-1276-05 L39-0479-05 L39-0495-05	SMALL FIXED INDUCTOR(100UH) SMALL FIXED INDUCTOR(100UH) COIL TOROIDAL COIL(7MHZ) TOROIDAL COIL(TAP 19.5T)		
L112 T1 ,2 T110-112		*	L39-0494-05 L92-0103-05 L92-0117-05	TOROIDAL COIL(1.9MHZ 22.5T) TOROIDAL CORE TOROIDAL CORE		
N W	11, 21 2B, 21		N87-3006-46 N88-3006-46	BRAZIER HEAD TAPTITE SCREW FLAT HEAD TAPTITE SCREW		
R1 ,2 R3 R4 R5 -23 R24 ,25			RD14BB2E101J RK73FB2A102J RD14BB2E470J RK73FB2AXXXJ RD14BB2E100J	RD 100 J 1/4W CHIP R 1.0K J 1/10W RD 47 J 1/4W CHIP R RD 10 J 1/4W		
R26 -32 R33 R34 VR101, 102 W6 -11	3H		RK73FB2AXXXJ RD14BB2E101J RK73FB2A472J R01-3435-05 001-0005-05	CHIP R RD 100 J 1/4W CHIP R 4.7K J 1/10W TRIM POT. 10K-F COATING WIRE		
W12 -17 W18 -28 W29 -31 W32 W34			R92-0679-05 R92-0670-05 R92-0679-05 R92-0670-05 R92-0670-05	CHIP R 0 OHM CHIP R 0 OHM CHIP R 0 OHM CHIP R 0 OHM CHIP R 0 OHM		
W35 ,36 W37			R92-0679-05 R92-0670-05	CHIP R 0 OHM CHIP R 0 OHM		
K1 K101-103 K105-108		*	S51-2407-05 S76-0401-05 S76-0401-05	RELAY RELAY RELAY		
MAT1, 2	3H		T42-0453-05	DC MOTOR ASSY		
D1 ,2 D3 -8 D10 D101-103 D105-108			1N60 1SS226 1S1555 1S1555 1S1555	DIODE DIODE DIODE DIODE DIODE		
D109, 110 1C1			RLS73 SN74S74N	DIODE 1C(ONE SHOT MULTI)		

E: Scandinavia & Europe K: USA P: Canada W: Europe

U: PX(Far East, Hawaii) T: England M: Other Areas

UE: AAFES(Europe) X: Australia

▲ indicates safety critical components.

# TS-850S

## PARTS LIST

\* New Parts

Parts without Parts No. are not supplied.

Les articles non mentionnés dans le Parts No. ne sont pas fournis.

Teile ohne Parts No. werden nicht geliefert.

AT UNIT (X53-3340-00)

VCO2 (X58-3390-03)

VOX (X59-1080-00)

DC-DC (X59-1100-00)

FM MIC (X59-3000-03)

Ref. No. 参照番号	Address 位置	New Parts 新	Parts No. 部品番号	Description 部品名 / 規格	Desti- nation 仕向	Re- marks 備考
IC2 ,3 IC4 ,5 IC6 IC7 Q1 ,2  Q3 Q4 Q5			TC4066BP BA6109U2 NJM2903S MC78L05M 2SC2714(Y)  DTC114EK 2SA1204(Y) DTC114EK	IC(ANALOG/ DIGITAL SW) IC(MOTOR DRIVER) IC(DUAL COMPALATOR) IC(VOLTAGE REGULATOR/ +5V) TRANSISTOR  DIGITAL TRANSISTOR TRANSISTOR DIGITAL TRANSISTOR		
<b>VCO2 (X58-3390-03)</b>						
C1 C2 C3 -7 C8 ,9 C10  C11 TC1  L1 L2  D1 Q1 Q2			B42-2437-04  CK73FB1H102K CC73FSL1H101J CC73FCH1HXXXD CK73FB1H102K CC73FCH1H010CMU  CK73FB1H102K C05-0331-05  L33-0690-05 L34-2353-05  1SV164 2SK508NV(K52) 2SC2714(Y)	LABEL  CHIP C 1000PF K CHIP C 100PF J CHIP C CHIP C 1000PF K CHIP C 1.0PF C  CHIP C 1000PF K TRIMMING CAP 10PF  CHOKE COIL(3.3UH) COIL  DIODE CHIP FET TRANSISTOR		
<b>VOX (X59-1080-00)</b>						
C1 C2  R2 ,3 W1 -3  D1 ,2 IC1 IC2 Q1			CK73FB1H102K CK73FB1E223K  RK73FB2AXXXJ R92-0670-05  DAP202(K) NJM2904M TC4001BF 2SC2712(Y)	CHIP C 1000PF K CHIP C 0.022UF K  CHIP R CHIP R 0 OHM  DIODE IC(OP AMP X2) IC(NOR X6) TRANSISTOR		
<b>DC-DC (X59-1100-00)</b>						
C1 ,2  JR1 -3 R1 -5  D1 Q1 ,2 Q3			CK73FB1H222K  R92-0670-05 RK73FB2AXXXJ  1SS226 2SC2712(Y) 2SA1162(Y)	CHIP C 2200PF K  CHIP R 0 OHM CHIP R  DIODE TRANSISTOR TRANSISTOR		
<b>FM MIC (X59-3000-03)</b>						
C1 C2 C3 C4 C5  JR1 R1 -9  IC1 Q1			CC73FCH1H101J CK73FB1H561K CC73FCH1H390J CK73FB1H102K CK73FB1E223K  R92-0670-05 RK73FB2AXXXJ  NJM4558M 2SC2712(Y)	CHIP C 100PF J CHIP C 560PF K CHIP C 39PF J CHIP C 1000PF K CHIP C 0.022UF K  CHIP R 0 OHM CHIP R  IC(OP AMP X2) CHIP TRANSISTOR		

E: Scandinavia & Europe K: USA P: Canada W: Europe

U: PX(Far East, Hawaii) T: England M: Other Areas

UE: AAFES(Europe) X: Australia

 indicates safety critical components.

# TS-850S



## PARTS LIST

× New Parts

Parts without Parts No. are not supplied.

Les articles non mentionnés dans le Parts No. ne sont pas fournis.

Telle ohne Parts No. werden nicht geliefert.

TRX (X59-3680-01)  
 AGC (X59-3820-00)  
 SM AMP (X59-3830-00)  
 MIC SW (X59-3840-00)  
 MIC AMP (X59-3850-00)  
 DELAY (X59-3860-00)  
 BK IN (X59-3870-00)

Ref. No. 参照番号	Address 位置	New Parts 新	Parts No. 部品番号	Description 部品名 / 規格	Desti- nation 仕向	Re- marks 備考
<b>TRX (X59-3680-01)</b>						
R151-156 Q151,152 Q153-155			RK73FB2AXXXJ 2SA1213(Y) DTC114TK	CHIP R TRANSISTOR DIGITAL TRANSISTOR		
<b>AGC (X59-3820-00)</b>						
C1 C2 C3 C4 C5 ,6		*	C92-0024-05 C92-0020-05 C92-0023-05 C92-0037-05 C92-0023-05	ERECTRO 2.2UF 50WV ERECTRO 0.22UF 50WV ERECTRO 1UF 50WV ELECTRO 10UF 16WV ERECTRO 1UF 50WV		
C7 C8		*	C92-0020-05 CK73FB1E103K	ERECTRO 0.22UF 50WV CHIP C 0.01UF K		
R1 -3			RK73FB2AXXXJ	CHIP R		
<b>SM AMP (X59-3830-00)</b>						
C1 C2			CK73EF1C105Z CK73FB1E103K	CHIP C 1.0UF Z CHIP C 0.01UF K		
R1 -6			RK73FB2AXXXJ	CHIP R		
IC1 Q1			NJM2904M DTC124EK	IC(OP AMP X2) DIGITAL TRANSISTOR		
<b>MIC SW (X59-3840-00)</b>						
C1 -3			C92-0004-05	CHIP TAN 1.0UF 16WV		
R1 -4			RK73FB2AXXXJ	CHIP R		
IC1 Q1			TC4066BF DTC124EK	IC(BILATERAL SWITCH X4) DIGITAL TRANSISTOR		
<b>MIC AMP (X59-3850-00)</b>						
C1 C2 C3 C4 C5		*	C92-0004-05 CC73FSL1H101J C92-0536-05	CHIP TAN 1.0UF 16WV CHIP C 100PF J CHIP TAN 10UF 10WV		
C6 C7		*	CK73EF1C105Z C92-0536-05	CHIP C 1.0UF Z CHIP TAN 10UF 10WV		
C6 C7		*	C92-0004-05 C92-0536-05	CHIP TAN 1.0UF 16WV CHIP TAN 10UF 10WV		
R1 -13 W1			RK73FB2AXXXJ R92-0679-05	CHIP R CHIP R 0 OHM		
Q1 ,2 Q1 ,2 Q3		*	2SC3324(G) 2SC3722K(R) DTC124EK	TRANSISTOR TRANSISTOR DIGITAL TRANSISTOR		
<b>DELAY (X59-3860-00)</b>						
C1 R1 -3 W1 -6			CK73FF1E104Z RK73FB2AXXXJ R92-0670-05	CHIP C 0.1UF Z CHIP R CHIP R 0 OHM		
D1 ,2 D3 IC1			RLS73 DAN202K TC4538BF	DIODE DIODE IC(ONE SHOT MULT)		
<b>BK IN (X59-3870-00)</b>						
C1 -3			CK73FB1EXXXK	CHIP C		

E: Scandinavia & Europe K: USA P: Canada W: Europe

U: PX(Far East, Hawaii) T: England M: Other Areas

UE: AAFES(Europe) X: Australia

△ indicates safety critical components.



# TS-850S

## PARTS LIST

× New Parts

Parts without Parts No. are not supplied.

Les articles non mentionnés dans le Parts No. ne sont pas fournis.

Teile ohne Parts No. werden nicht geliefert.

BK IN (X59-3870-00)  
 BK SW (X59-3880-00)  
 PROC AMP (X59-3890-00)  
 AIP SW (X59-3900-00)  
 NB2 (X59-3910-00)  
 LCD ASSY (B38-0350-15)

Ref. No. 参照番号	Address 位置	New Parts 新	Parts No. 部品番号	Description 部品名 / 規格	Desti- nation 仕 向	Re- marks 備考
C4 ,5 C6			CK73FF1E104Z CK73EB1E683K	CHIP C 0.1UF Z CHIP C 0.068UF K		
R1 -6 W1 -6			RK73FB2AXXXJ R92-0670-05	CHIP R CHIP R 0 OHM		
D1 D2 ,3 IC1 IC2 Q1			DAN202K RLS73 TC4069UBF TC4011BF DTC124EK	DIODE DIODE IC(INVERTER X6) IC(NAND X4) DIGITAL TRANSISTOR		
<b>BK SW (X59-3880-00)</b>						
C1 R1 ,2 W1 -8 D1 IC1 Q1 -3			CK73FF1E104Z RK73FB2A103J R92-0670-05 RLS73 TC4066BF DTC124EK	CHIP C 0.1UF Z CHIP R 10K J 1/10W CHIP R 0 OHM DIODE IC(BILATERAL SWITCH X4) DIGITAL TRANSISTOR		
<b>PROC AMP (X59-3890-00)</b>						
C1 C2 ,3 C4 C5 C6 -9 R1 -11 W1 ,2 D1 D2 Q1 ,2 Q2 ,2			CK73FB1E103K CK73FF1E104Z CC73FSL1H121J CK73FB1E103K CK73FF1E104Z RK73FB2AXXXJ R92-0670-05 HSM88AS RLS73 2SC3324(G) 2SC3722K(R)	CHIP C 0.01UF K CHIP C 0.1UF Z CHIP C 120PF J CHIP C 0.01UF K CHIP C 0.1UF Z CHIP R CHIP R 0 OHM DIODE DIODE TRANSISTOR TRANSISTOR		
<b>AIP SW (X59-3900-00)</b>						
R1 -3 W1 -3 D1 Q1 Q2 Q3 Q4 Q5 Q6 Q7 ,8 Q9 ,10			RK73FB2AXXXJ R92-0670-05 DAN202K DTA143TK DTC124EK DTA143TK DTC124EK 2SA1162(Y) DTC124EK DTA143TK DTC124EK	CHIP R CHIP R 0 OHM DIODE DIGITAL TRANSISTOR DIGITAL TRANSISTOR DIGITAL TRANSISTOR DIGITAL TRANSISTOR TRANSISTOR DIGITAL TRANSISTOR DIGITAL TRANSISTOR DIGITAL TRANSISTOR		
<b>NB2 (X59-3910-00)</b>						
C1 -2 C3 R1 -5 W1 -3 IC1 Q1 ,2			CK73FB1HXXXX CK73EF1E474Z RK73FB2AXXXJ R92-0670-05 TC4011BF DTC114EK	CHIP C CHIP C 0.47UF Z CHIP R CHIP R 0 OHM IC(NAND X4) DIGITAL TRANSISTOR		
<b>LCD ASSY (B38-0350-15)</b>						
CFL		*	B11-1022-08 B30-2015-08	LAMP HOUSE LAMP(COLD CATHODE TUBE)		

E: Scandinavia & Europe K: USA P: Canada W: Europe

U: PX(Far East, Hawaii) T: England M: Other Areas

UE: AAFES(Europe) X: Australia

△ indicates safety critical components.

# TS-850S

## PARTS LIST

× New Parts

Parts without Parts No. are not supplied.

Les articles non mentionnés dans le Parts No. ne sont pas fournis.

Teile ohne Parts No. werden nicht geliefert.

LCD ASSY (B38-0350-15)

Ref. No. 参照番号	Address 位置	New Parts 新	Parts No. 部品番号	Description 部品名 / 規格	Desti- nation 仕向	Re- marks 備考
LCD		*	B38-0362-08	LCD ELEMENT		
			E40-5467-05	CONNECTOR		
		*	J21-4360-08	LCD HOLDER		
INV		*	W02-0677-08	INVERTER		
IC1			LC7582	IC(LCD DRIVE)		
IC2			MSM5265GS-V1K	IC(LCD DRIVE)		

Downloaded by   
  
 Amateur Radio Directory

E: Scandinavia & Europe K: USA P: Canada W: Europe

U: PX(Far East, Hawaii) T: England M: Other Areas

UE: AAFES(Europe) X: Australia

 indicates safety critical components.

# TS-850S

## EXPLODED VIEW

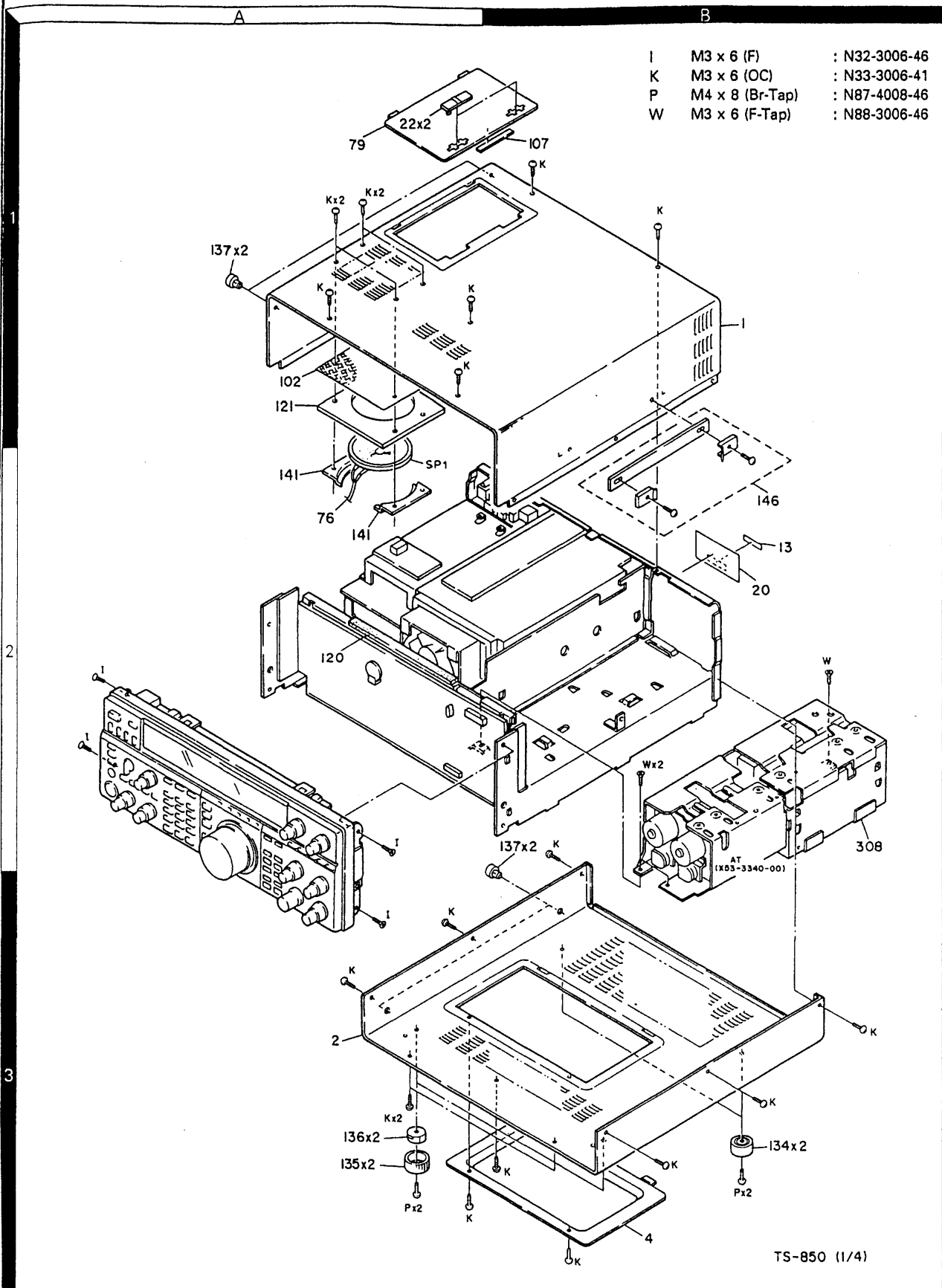



# TS-850S

## EXPLODED VIEW

A	3 x 8.8,+Pan head	: N09-0372-04	L	M2.6 x 6 (Br-Tap)	: N87-2606-46
B	M4 x 16	: N09-0682-04	M	M2.6 x 8 (Br-Tap)	: N87-2608-46
D		: N14-0115-05	N	M3 x 6 (Br-Tap)	: N87-3006-46
E		: N14-0509-05	O	M3 x 8 (Br-Tap)	: N87-3008-46
F		: N15-1040-46	Q	M2.6 x 8 (F-Tap)	: N88-2608-46

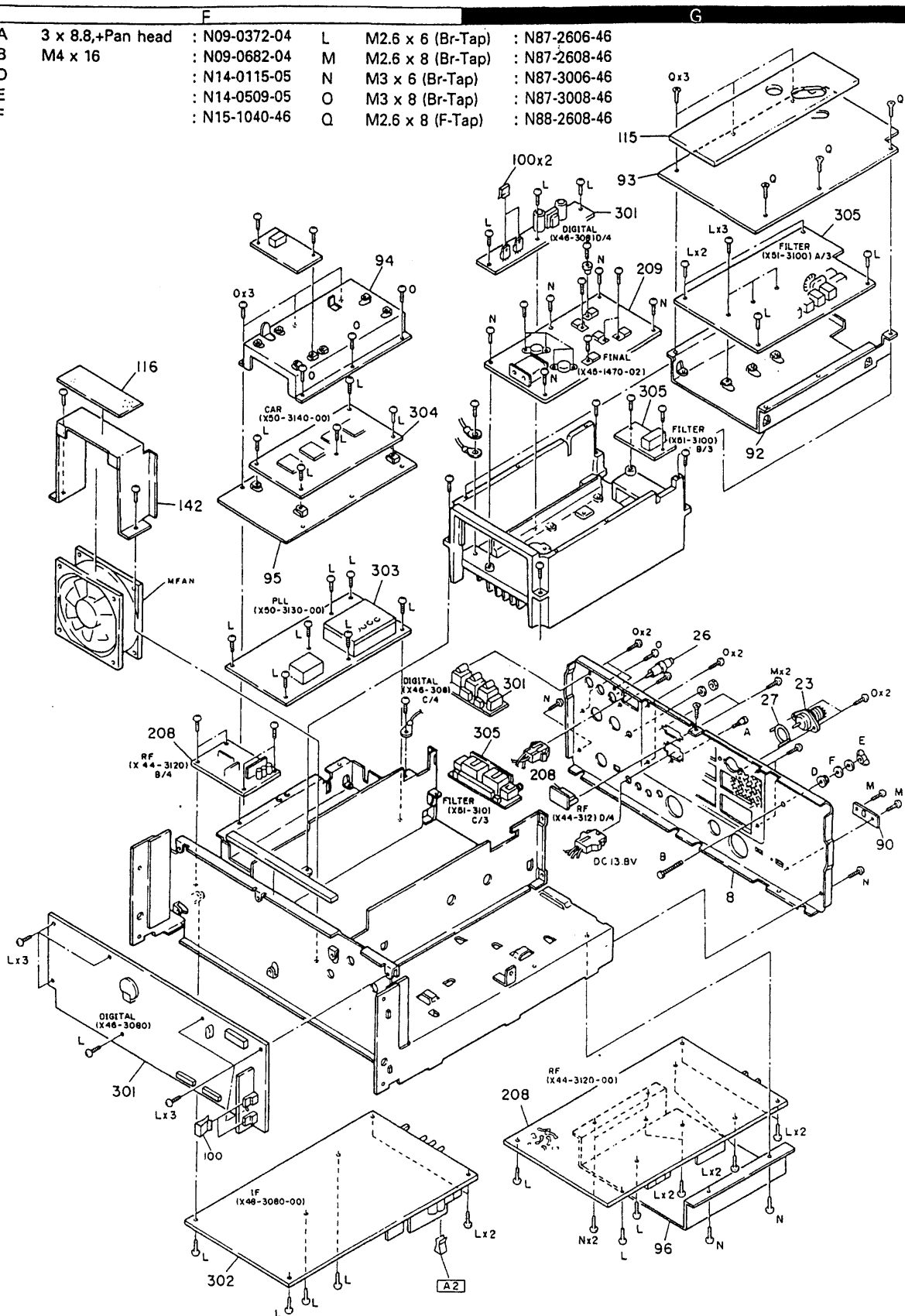

TS-850 (3/4)

# TS-850S

## EXPLODED VIEW

N M3 x 6 (Br-Tap) : N87-3006-46  
W M3 x 6 (F-Tap) : N88-3006-46

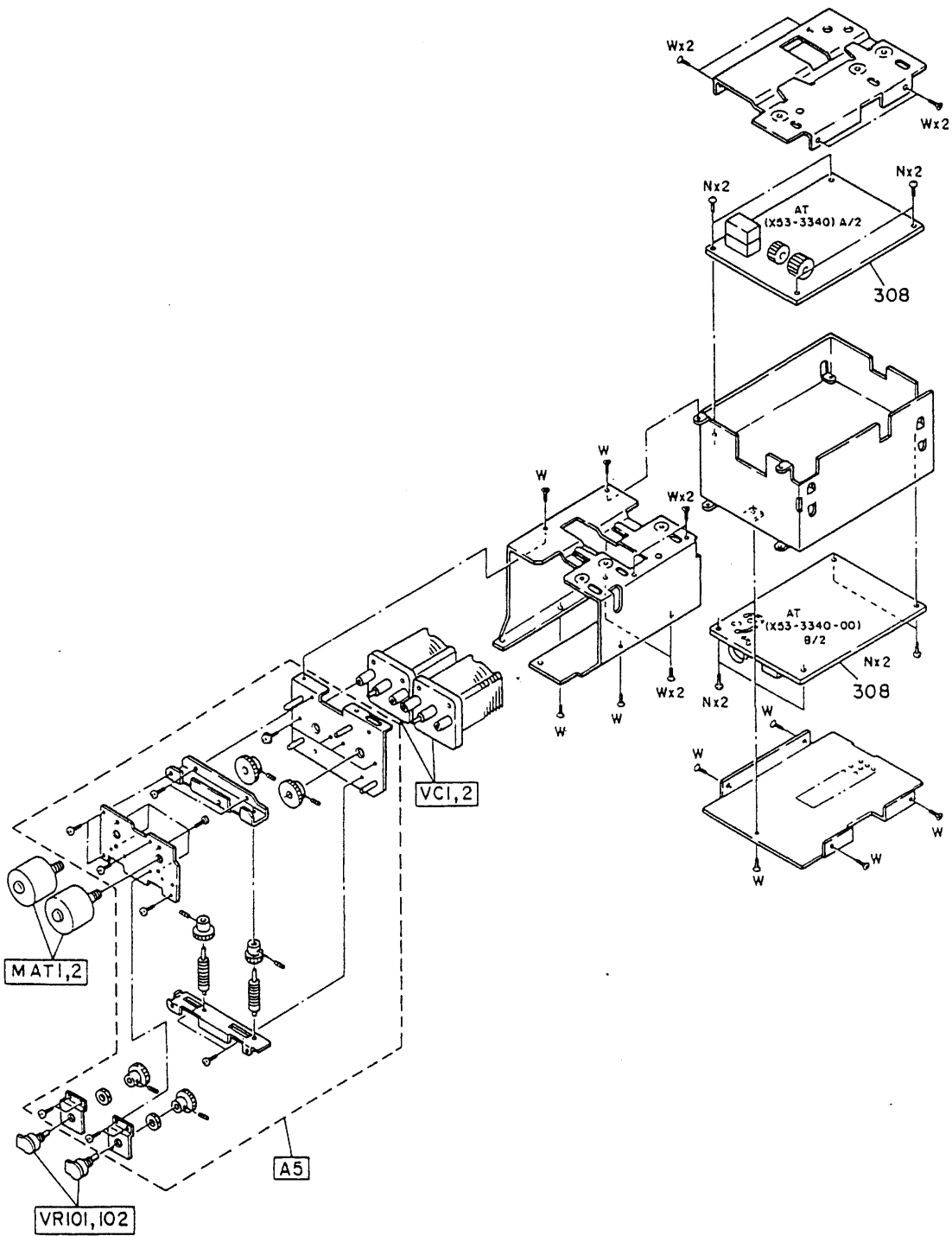

TS-850 (4/4)

## PACKING

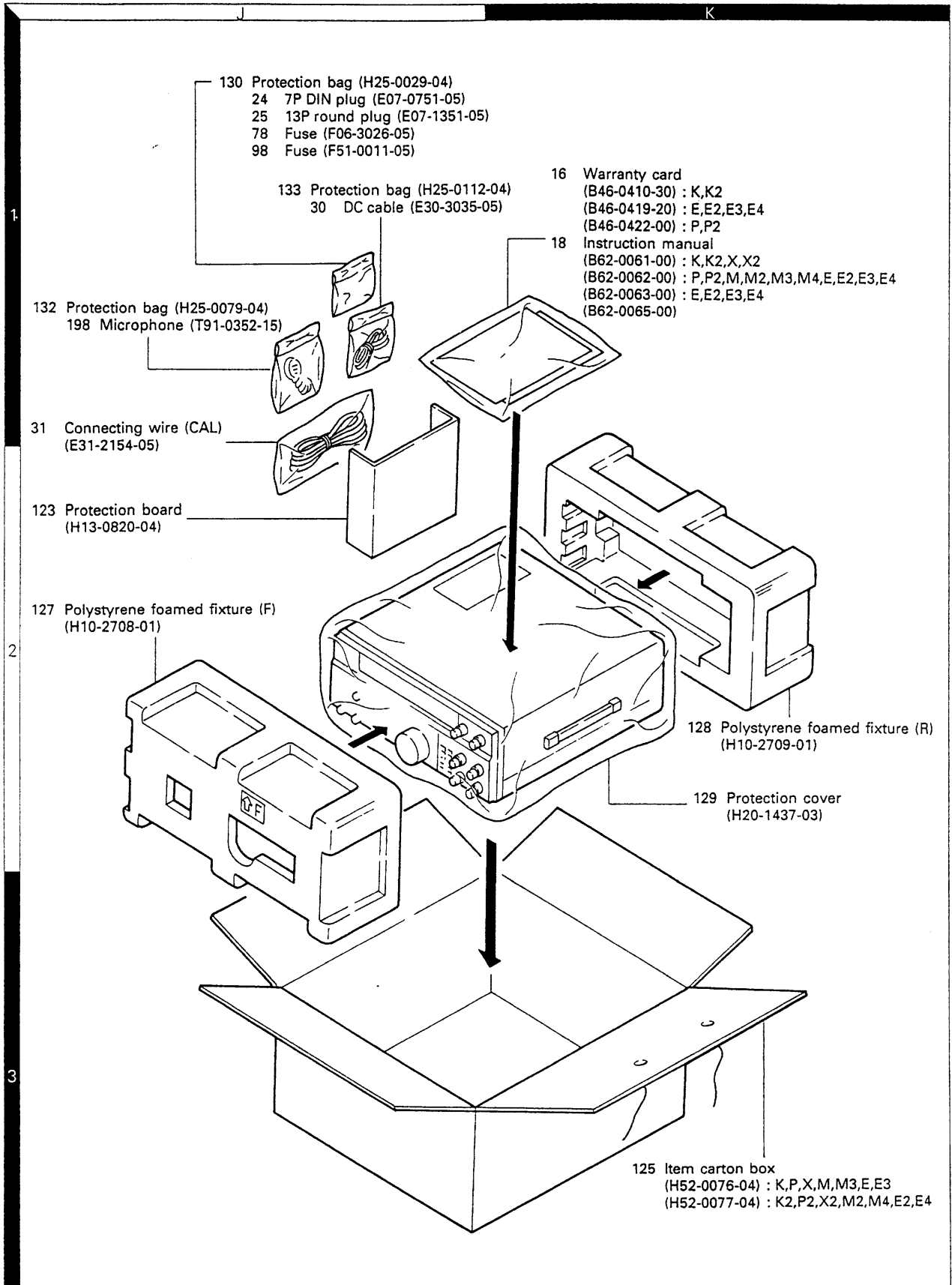

# TS-850S

## ADJUSTMENT

### Required Test Equipment

#### 1. DC Voltmeter (DC V.M)

- 1) Input resistance : More than 1M $\Omega$
- 2) Voltage range : 1.5 to 1000V AC/DC

**Note** : A high-precision multimeter may be used. However, accurate readings can not be obtained for high-impedance circuits.

#### 2. DC Ammeter

- 1) Current range : 100mA, 1.5A, 15A, High-precision ammeter may be used.

#### 3. RF VTVM (RF V.M)

- 1) Input impedance : 1M $\Omega$  and less than 3pF, min.
- 2) Voltage range : 10mV to 300V
- 3) Frequency range : 10kHz to 500MHz

#### 4. AF Voltmeter (AF V.M)

- 1) Frequency range : 50Hz to 10kHz
- 2) Input resistance : 1M $\Omega$  or greater
- 3) Voltage range : 10mV to 30V

#### 5. AF Generator (AG)

- 1) Frequency range : 200Hz to 5kHz
- 2) Output : 1mV or less to 1V, low distortion

#### 6. AF Dummy Load

- 1) Impedance : 8 $\Omega$
- 2) Dissipation : 3W or greater

#### 7. Oscilloscope

Requires high sensitivity, and external synchronization capability (150MHz or greater).

#### 8. Sweep Generator

- 1) Center frequency : 50kHz to 90MHz
- 2) Frequency deviation : Maximum  $\pm 35$ MHz
- 3) Output voltage : 0.1V or greater
- 4) Sweep rate : At least 0.5 sec/cm

#### 9. Standard Signal Generator (SSG)

- 1) Frequency range : 50kHz to 50MHz
- 2) Output : -20dB/0.1 $\mu$ V to 120dB/1V
- 3) Output impedance : 50 $\Omega$
- 4) AM and FM modulation can be possible.

**Note** : Generator must be frequency stable.

#### 10. Frequency Counter (f. counter)

- 1) Minimum input voltage : 50mV
- 2) Frequency range : 150MHz or greater

#### 11. Noise Generator

Must generate ignition noise containing harmonics beyond 30MHz

#### 12. RF Dummy Load

- 1) Impedance : 150 $\Omega$  and 50 $\Omega$
- 2) Dissipation : 150W or greater

#### 13. Linear Detector

- 1) Frequency range : 30MHz

#### 14. Power Meter

- 1) Impedance : 50 $\Omega$
- 2) Dissipation : 300W continuous or greater
- 3) Frequency limits : 60MHz or greater

#### 15. Spectrum Analyzer

- 1) Frequency range : 100kHz to 110MHz or greater
- 2) Bandwidth : 1kHz to 3MHz

#### 16. Detector

- 1) For adjustment of BPF

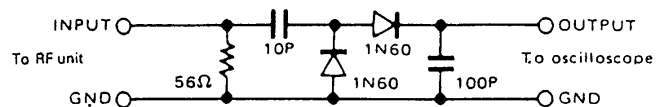

- 2) For adjustment of PLL/VCO BPF

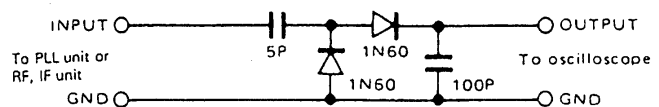

#### 17. Directional Coupler

#### 18. Monitor Receiver

R-1000 class

#### 19. Microphone

MC-43S or MC-60/60S8

#### 20. Tracking Generator

### Preference

Japanese "SG"	American "SG"
-6dB	0.25 $\mu$ V
0dB	0.5 $\mu$ V
6dB	1 $\mu$ V
12dB	2 $\mu$ V
24dB	8 $\mu$ V
30dB	15.8 $\mu$ V
40dB	50 $\mu$ V
50dB	158 $\mu$ V
60dB	500 $\mu$ V
70dB	1.58mV
80dB	5mV
90dB	15.8mV
100dB	50mV
120dB	0.5V



## ADJUSTMENT

### Preparation

#### • Setting

Set the mark position of round knob as drawing below.

There should not comes out easily.

Push knob are all OFF.

### Front Panel

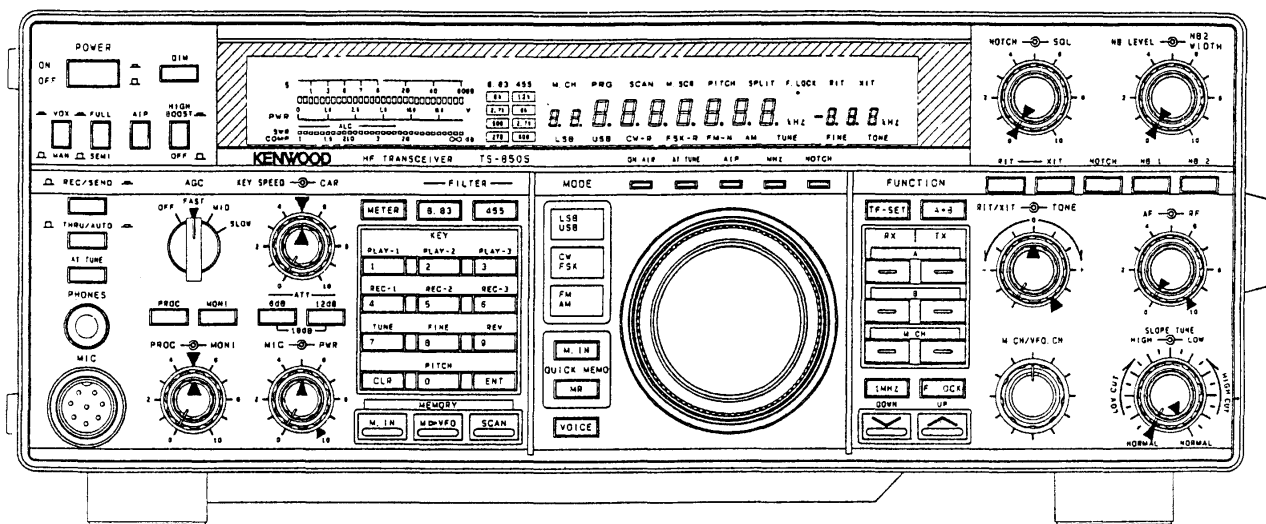

### Rear Panel

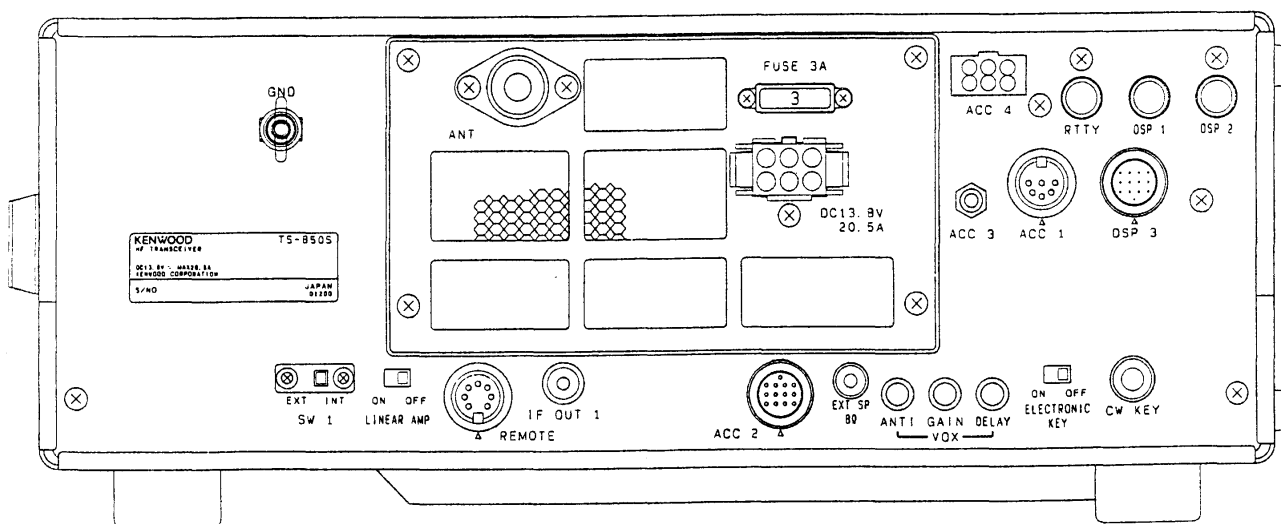

Downloaded by   
  
 Amateur Radio Directory

# TS-850S

## ADJUSTMENT

### PLL Section Adjustment

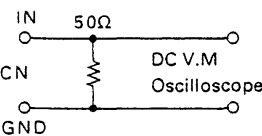
Item	Condition	Measurement			Adjustment			Specifications/Remarks
		Test-equipment	Unit	Terminal	Unit	Parts	Method	
1. 20MHz frequency	1) POWER : ON MODE : FM STBY : REC	f. counter	CAR	TP1	PLL	TC5	20,000,000Hz ADJ.	20MHz ± 20Hz
2. L34,35 adjustment	1) MODE : FM STBY : REC	RF V.M	PLL	IC1 pin 2	PLL	L34,35	Level MAX	
3-1. L19,20,21 adjustment	1) Display f. : 14.250MHz MODE : FM STBY : REC	RF V.M	PLL	TP4	PLL	L19,20 L21	Level MAX	
3-2. TP4 frequency	2) Display f. : 14.250MHz	f. counter						Check
4. VCO1 adjustment	1) Display f. : 30kHz	DC V.M	PLL	TP1	PLL	TC1	2.3V	2.3 ± 0.03V
4-1. VCO1 level check	2) Display f. : 7.499MHz						Check	6.0~8.0V
5. VCO2 adjustment	1) Display f. : 7.500MHz	DC V.M	PLL	TP1	PLL	TC2	2.3V	2.3 ± 0.03V
5-1. VCO2 level check	2) Display f. : 14.499MHz						Check	6.0~8.0V
6. VCO3 adjustment	1) Display f. : 14.500MHz	DC V.M	PLL	TP1	PLL	TC3	2.3V	2.3 ± 0.03V
6-1. VCO3 level check	2) Display f. : 21.499MHz						Check	6.0~8.0V
7. VCO4 adjustment	1) Display f. : 21.500MHz	DC V.M	PLL	TP1	PLL	TC4	2.3V	2.3 ± 0.03V
7-1. VCO4 level check	2) Display f. : 30.000MHz						Check	6.0~8.0V
8. LO2 VCO adjustment (X58-3390-03)	1) Display f. : 30.000MHz	DC V.M	PLL	TP2	VCO2 (X58-3390)	TC1	5.0V	5.0 ± 0.03V
9. Level check LO1 (CN5) LO2 (CN6) 20MHz (CN2) 10kHz (CN9)	1) Display f. : 14.250MHz MODE : FM STBY : REC  	DC V.M	PLL	CN5			Check	-5~+2dBm
				CN6			Check	-1~+6dBm (64.220MHz)
				CN2			Check	-10~+0dBm (20.000MHz)
				CN9			Check	500~1000mVp-p (10.0kHz)
10. 20MHz frequency	1) MODE : FM STBY : REC	f. counter	CAR	TP1	PLL	TC5	20,000,000Hz ADJ.	20MHz ± 5Hz

## ADJUSTMENT

### Receiver and Transmitter Section Adjustment

Item	Condition	Measurement			Adjustment			Specifications/Remarks
		Test-equipment	Unit	Terminal	Unit	Parts	Method	
1. Display check and reset	1) DC IN : 13.8V Connect the DC plug POWER : ON After checked POWER : OFF Pushing A=B, POWER : ON				Display		Reset display Display f. : 14.000.00kHz MODE : USB FUNCTION RX : A FUNCTION TX : A METER : ALC FILTER 8.83 : 2.7K FILTER 455 : 2.7K	Must display correctly. Must be no generation of smoke or abnormal noise. Should be at the reset frequency.
2. Reference oscillation		f. counter	CAR	TP1	PLL	TC5	20.000.000Hz ADJ.	±20Hz
3. Slope tune, RIT/XIT	1) POWER : OFF Pushing F. LOCK key down POWER : ON SLOPE TUNE HI/LOW : Left turn MAX Turn the click encoder (M.CH) and set the display to 03 (MENU No. 3) HI/LOW VR : After concluded right turn HI MAX	DISP			SW A (A/6)	VR4	Set the display to 0.	±1
	2) Display : 04 (MENU No. 4) After adjusted SLOPE TUNE HI : Normal (right turn MAX)					VR5	Set the display to 0.	±1
	3) RIX/XIT VR : Mechanical center Display : 02 (MENU No. 2) CLR key : Push					VR3	Set the display to 0. 0	0
4. AGC	1) POWER : OFF to ON Display f. : 14.000MHz MODE : USB RF GAIN : MAX	DC V.M	IF	TP1	IF	VR15	2.8V ADJ.	±0.01V
	2) MODE : FM					VR14	2.8V ADJ.	±0.01V
5. ALC voltage	1) Remove RF unit CN2. MODE : USB Display f. : 14.200MHz PWR : MAX STBY : SEND	DC V.M	RF	TP3	RF	VR14	2.7V	±0.05V
6. MCF	1) Tracking generator output : -10dBm Center f. : 73.050MHz AGC : OFF	Spectrum analyzer Tracking generator	RF	TP2 (CN6) TP1 (CN5)	RF	L59~L62	Repeat 2~3 times. Adjust so that gain is max. and band shown at right becomes flat.	

# TS-850S

## ADJUSTMENT

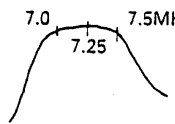
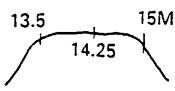
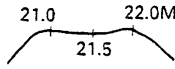
Item	Condition	Measurement			Adjustment			Specifications/Remarks
		Test-equipment	Unit	Terminal	Unit	Parts	Method	
7. BPF	1) ENT 7 ENT key : Push Display f. : 7.000MHz MODE : Arbitrary AIP : OFF Tracking generator output : -20dBm	Spectrum analyzer Tracking generator	RF Rear panel	TP4 (CN27) ANT	RF	L19~L21		
	L28~L30							
	L34~L36							
8-1. IF AMP (1)	1) Display f. : 14.2MHz MODE : CW CAR : 10 o'clock Connect test instrument to IF unit CN6. Spectrum analyser SPAN : 50kHz ST : 305ms RBW : 1kHz STBY : SEND	50Ω load RF V.M or Synchro scope or Spectrum analyzer	RF	CN2	IF	L5~L7	Set 14.2MHz signal to MAX.	
	8-2. IF AMP (2)					2) MODE : CW CAR : MAX Connect test instrument to RF unit CN2. STBY : SEND	RF	L77,79 L80,82 L83,84 L87 VR2
9. MIX balance	1) ENT 249 ENT key : Push Display f. : 24.900MHz STBY : SEND After adjusted connect CN2.	Spectrum analyzer	RF	CN2	RF	VR3	±1.65MHz Spurious : MIN	-70dBm or less with respect to 24.9MHz and 10dBm.
10. MIX BAL	1) ENT 001 ENT key : Push Display f. : 0.100MHz MODE : LSB AF VR : MAX SLOPE TUNE HI : Fully CW position LOW : Fully CCW position TONE : Fully CW position After adjusted AF VR : MIN	AF V.M DM. SP	Rear panel	EXT. SP	RF	VR1	Adjust noise level to minimum level.  Although noise will be produced when the VR is turning, this is not malfunction.	1kHz ± 100Hz
11. RF, IF AMP	1) ENT 141 ENT key : Push Display f. : 14.100MHz MODE : USB AGC : OFF AIP : OFF AF VR : 0.63V/8Ω SSG f. : 14.101MHz SSG ATT : -6dBμ Make adjustments at as low at input level as possible.	SSG DM. SP Oscilloscope AF V.M	Rear panel	ANT EXT. SP	RF	L66,81 L67,68 L69,70	Repeat 2 times for MAX AF output reading.	
	2) FILTER 8.83 SW : Set to the position where the display disappears. After adjusted Return to 2.7kHz SUB : OFF					IF	L1~L4 L17~L19 VR17	Set just prior to level dropping turning to the left from the AF output MAX position
					RF	L74,75	MAX for AF output.	

## ADJUSTMENT

Item	Condition	Measurement			Adjustment			Specifications/Remarks
		Test-equipment	Unit	Terminal	Unit	Parts	Method	
12. IF OUT 1	1) SSG ATT : 90dB $\mu$ AF VR : MIN	SSG Synchro scope	Rear panel	ANT IF OUT 1	RF	L64,65	Adjust 8.83MHz signal to MAX level.	
13. S-meter adjustment and RX GAIN check	1) Display f. : 14.100MHz MODE : USB AGC : OFF RF GAIN : MAX SSG RF : OFF	DC V.M	IF	TP2	IF	VR12	0.1V	$\pm 0.01V$
	2) AGC : FAST SSG ATT : 6dB $\mu$					VR13	MAX	
						L17	S1 (After 3 dots lights)	
	3) SSG ATT : 32dB $\mu$					VR13	S9 (After S9 lights)	
						4) SSG ATT : 6dB $\mu$	VR17	S1
	5) SSG ATT : 32dB $\mu$							Check
6) SSG ATT : 6dB $\mu$			Check	S1 lit, $\pm 3dB\mu$				
14. ATT check	1) Display f. : 14.100MHz AGC : OFF SSG : 6dB $\mu$ AF VR : 1V/8 $\Omega$	SSG DM. SP Oscilloscope AF V.M	Rear panel	ANT EXT. SP	Front panel	ATT SW 0dB 6dB 12dB 18dB	Check AF output should be lowered 6dB at time.	SSG ATT : Within $\pm 3dB$ ATT SW 0dB $\rightarrow$ 1V (0dB) 6dB $\rightarrow$ 0.5V (-6dB) 12dB $\rightarrow$ 0.25V (-12dB) 18dB $\rightarrow$ 0.15V (-18dB)
15. FM GAIN	1) ENT 282 ENT key : Push Display f. : 28.200MHz MODE : FM SSG f. : 28.200MHz MOD : 1kHz DEV : 3kHz ATT : 20dB $\mu$				IF	L21	AF output MAX.	
16. FM S-meter	1) SSG ATT : 30dB $\mu$				IF	VR10	Set the S-meter to just before 60 dots lights.	

# TS-850S

## ADJUSTMENT

Item	Condition	Measurement			Adjustment			Specifications/Remarks	
		Test-equipment	Unit	Terminal	Unit	Parts	Method		
17. NB	1) SSG ATT : 6dB $\mu$	SSG DC V.M	Rear panel	ANT	RF (B/4)	L602 L603	TP600 output MIN		
	2) ENT 212 ENT key : Push Display f. : 21.200MHz MODE : USB AGC : FAST AF VR : Arbitrary NB1 : ON NB LEVEL : 12 o'clock	Noise generator Speaker		ANT EXT. SP				Adjust output of noise generator to small input (S1) and large input (S9) and check each.	Noise should disappear.
	3) NB2 WIDTH : MIN NB2 : ON  After adjusted NB1 and NB2 : OFF						Check	When output SW of noise generator is set to NB2 and TIME VR is turned all the way to the right and left, noise should disappear by varying the set NB2 WIDTH.	
18. Beep tone adjustment	1) AF VR : MIN CW/FSK key : 1 push	DM. SP Oscilloscope	Rear panel	EXT. SP	IF	VR4	0.2Vp-p	0.1-0.3Vp-p	
19. Voice check (equipped on VS-2)	1) AF VR : Arbitrary						Check	When the VOICE key on the front panel pushed once, the displayed frequency can be heard vocally.	
20. S/N check	1) Display f. : Indicated below AF VR : 1.0V/8 $\Omega$ SSG f. : Indicated below However, USB : +1kHz LSB : -1kHz								Note : As AIP will be turned on automatically at frequencies of 9.5kHz or less, turn it off with the AIP SW.
	Frequency (M. CH)	MODE	SG ATT	SG MOD	DEV				
	100kHz	AM	14dB $\mu$	1kHz	30%			S/N measurement	10dB or more
	1.500MHz	AM	36dB $\mu$					MAX sensitivity measurement	0.7V/8 $\Omega$ or more
	1.800MHz	LSB	-6dB $\mu$	OFF					
	3.500MHz	LSB	-6dB $\mu$	OFF					
	5.500MHz	LSB	-6dB $\mu$	OFF					
	7.100MHz	LSB	-6dB $\mu$	OFF					
	10.100MHz	USB	-6dB $\mu$	OFF					
	12.500MHz	USB	-6dB $\mu$	OFF					
	14.100MHz	USB	-6dB $\mu$	OFF					
	18.100MHz	USB	-6dB $\mu$	OFF					
	21.100MHz	USB	-6dB $\mu$	OFF					
	24.800MHz	USB	-8dB	OFF					
29.800MHz	USB	-8dB	OFF						
29.800MHz	FM	-6dB $\mu$	1kHz	3kHz			SINAD sensitivity measurement	12dB SINAD or more	

## ADJUSTMENT

Item	Condition	Measurement			Adjustment			Specifications/Remarks	
		Test-equipment	Unit	Terminal	Unit	Parts	Method		
21. SSB squelch	1) ENT 141 ENT key : Push Display f. : 14.100MHz MODE : USB AGC : SLOW SSG f. : 14.101MHz SSG RF : OFF SQL VR : 12 o'clock	SSG DM. SP Oscilloscope AF V.M	Rear panel	ANT EXT. SP	IF	VR11	Set to the point squelch closes.		
	2) SSG ATT : 12dB $\mu$						Check		Squelch should open.
	3) SQL VR : MAX SSG ATT : 30dB $\mu$								Squelch should open.
22. FM squelch	1) ENT298 ENT key : Push Display f. : 29.800MHz MODE : FM SSG RF : OFF	SSG DM. SP Oscilloscope AF V.M	Rear panel	ANT EXT. SP			Adjust SQL VR is slowly increase noise just goes off.	Knob position 8 : 00 ~ 12 : 00	
	2) SSG ATT : -6dB $\mu$ MOD : 1kHz DEV : 3kHz						Check	Squelch should open.	
	3) SQL VR : MAX SSG ATT : 13dB $\mu$ After adjusted SQL VR : MIN							Squelch should open.	
23. Base current	1) Display f. : 14.1750MHz MODE : USB MIC VR : MIN CAR VR : MIN Final unit VR1, VR2 : MIN Connect ammeter + : EXT. power supply - : Power connector Adjust to minimum current with VR1 and VR2 in the final unit. STBY : SEND	Ammeter			Final	VR1	Current drain (Minimum current) + 200mA	First adjust VR1 and VR2 for minimum. Adjust VR1 for an increase of 200mA when switched to TX. Then adjust VR2 for 200mA over this reading.	
						VR2	Current drain (Minimum current) + driver current (200mA) + 200mA.		
24. NULL	1) ENT 035 ENT key : Push MODE : CW Display f. : 3.500MHz CAR VR : MIN RF unit VR7, VR8 : MIN STBY : SEND	DC V.M Power meter	Filter Rear panel	TP1 ANT	Filter	TC1	Turn up CAR set to 10W. Reduce the voltage to the minimum level by turning TC1.	Ref. 50mV or less	
25. ALC adjustment	1) Display f. : 14.200MHz CAR VR : MIN RF unit VR7 : MAX RF unit VR8 : MIN MODE : CW CAR VR : Turn slowly to the right starting at minimum. STBY : SEND	Power meter	Rear panel	ANT	RF	VR7	After checking that only an output of roughly 10W is generated when CAR VR is turned to MAX, adjust to 100W.	$\pm 5W$	

# TS-850S

## ADJUSTMENT

Item	Condition	Measurement			Adjustment			Specifications/Remarks
		Test-equipment	Unit	Terminal	Unit	Parts	Method	
26. ALC frequency characteristic	1) ENT 296 ENT key : Push Display f. : 29.600MHz CAR VR : MAX STBY : SEND	Power meter	Rear panel	ANT	Filter	VR1	90W	±5W
	2) ENT 142 ENT key : Push Display f. : 14.200MHz STBY : SEND						When the above range is exceeded during transmission, repeat the above adjustment.	
27. Power meter	1) PWR : MAX CAR VR : MAX STBY : SEND	Power meter	Rear panel	ANT	RF	VR9	Adjust power set to 90W.	90W dot should go out at 88W or higher by turning PWR.
28. Power down	1) ENT 287 ENT key : Push Display f. : 28.700MHz RF unit S1 : ON PWR : MAX STBY : SEND After adjusted S1 : OFF	Power meter	Rear panel	ANT	RF	VR4	55W	±5W
	2) TUNE : ON (7 key) PWR : MAX RF unit VR6 : MAX STBY : SEND After adjusted TUNE : OFF					VR6	55W	±5W
29. MIN power	1) PWR : MIN STBY : SEND	Power meter	Rear panel	ANT	RF	VR5	10W	20W or less
30. Power control tracking	1) MODE : CW PWR : MAX STBY : SEND Turn CAR VR and set to ALC meter zone MAX.	Power meter	Rear panel	ANT	RF	TC1	Reduced PWR to MIN and adjust TC1 so that ALC meter reaches zone MAX.	
31. Carrier point	1) ENT 142 ENT key : Push Display f. : 14.200MHz While pushing the F. LOCK key, POWER : ON (Display the MENU No. of M. CH) Display : 00 (MENU No. 00) MODE : USB/LSB 8.83MHz filter key : 6kHz AG1 : 900Hz/5mV AG2 : 3500Hz/5mV MIC : Level at which not activated STBY : SEND	Power meter	Rear panel	ANT	RF (D/4)	VR501	Adjust so that waveforms cross with LSB.	
		Oscilloscope					VR502	
	2) 8.83MHz filter key : 2.7kHz Turn the click encoder to set MENU 1. MODE : LSB/USB AG1 : 1kHz/5mV AG2 : 3.4kHz/5mV MIC : Turn slowly STBY : SEND  After adjusted CLR key : Push	AG AF V.M	Front panel	MIC		VR503	Adjust so that waveforms cross with USB.  Check so that waveforms cross with LSB. When the waveforms do not cross with LSB, adjust while changing the mode to set to the same waveform.	



## ADJUSTMENT

Item	Condition	Measurement			Adjustment			Specifications/Remarks		
		Test-equipment	Unit	Terminal	Unit	Parts	Method			
32. CAR suppression	1) Display f. : 14.2MHz MODE : USB/LSB MIC : MIN STBY : SEND After adjusted connect CN6.	50Ω load RF V.M or Synchro scope or Spectrum analyzer	RF	CN2	IF	VR8,9	Alternately turn the VR to set CAR to the MIN level. Should go to the minimum level when VR is turned all the way. Check both LSB and USB.	-50dB or less  There is a dip point near center position of the VR.		
33. PROC AMP and meter	1) PROC SW : ON PROC VR : Mechanical center position AG : 1kHz/10mV STBY : SEND	Power meter Oscilloscope  AG AF V.M	Rear panel	ANT	IF	L8	MAX Adjust MIC so that it remains constantly at roughly 40W.			
	2) Meter : COMP AG : 1kHz/1mV STBY : SEND PROC VR : Until the oscilloscope waveform becomes saturated.		Front panel	MIC			Adjust PROC VR and set to roughly 80% of oscilloscope waveform saturation.			
	3) AG : 1kHz/10mV STBY : SEND After adjusted, PROC SW : OFF				RF	VR13	Adjust so that 21dB dot lights.			
	4) AG : 1kHz/1mV STBY : SEND						Check	One dot of the COMP meter should be lit.		
34. ALC meter	1) Meter : ALC AG : 1kHz/5mV MODE : USB MIC VR : MIN RF unit VR12 : MAX STBY : SEND	Power meter  DC V.M	Rear panel	ANT	RF	VR11	Adjust prior to voltage deviation.	0V		
	2) AG : 1kHz/5mV STBY : SEND	AG AF V.M Power meter	Front panel	MIC			Adjust so that ALC meter one dot lights with MIC VR.			
	3) AG : 1kHz/10mV STBY : SEND					VR12	Adjust so that ALC meter lights to zone MAX.			
35. Spurious	1) ENT 249 ENT key : Push Display f. : 24.900MHz STBY : SEND	Spectrum analyzer	RF	CN2	RF	VR3	±1.65MHz Spurious level MIN.	-60dB or less (24.9MHz)		
36. SWR protection	1) MODE : CW CAR VR : MIN PWR : MAX RF unit VR8 : MAX STBY : SEND	150Ω dummy load Through-type power meter	Rear panel	ANT	RF	VR8	40W Note : Perform adjustment quickly.	±5W		
			<pre> graph LR     TS850[TS-850] --- 1m1[1m] --- PM((Power meter))     PM --- 1m2[1m] --- Dummy[Dummy]             </pre>							
37. SWR meter	1) ENT 18 ENT key : Push Display f. : 1.800MHz Meter : SWR STBY : SEND	150Ω dummy load	Rear panel	ANT	RF	VR10	SWR : 3 Adjust just after SWR 3 dot lights.			

# TS-850S

## ADJUSTMENT

Item	Condition	Measurement			Adjustment			Specifications/Remarks
		Test-equipment	Unit	Terminal	Unit	Parts	Method	
38. FM MAX DEV	1) ENT 282 ENT key : push Display f. : 28.800MHz MODE : FM CAR VR : MAX AG : 1kHz/50mV (K,P,M), 30mV (X,E) STBY : SEND	Power meter Linear detector AG AF V.M	Rear panel	ANT	RF (B/4)	VR603	±4.6kHz	±0.1kHz
			Front panel	MIC				
39. FM MIC SENS	1) AG : 1kHz/5mV (K,P,M), 3mV (X,E) STBY : SEND					VR601	±3kHz	±0.1kHz
40. FM NAR MAX DEV	1) 455 key : Push AG : 1kHz/50mV (K,P,M), 30mV (X,E) STBY : SEND					VR602	±2.3kHz	±0.1kHz FM-N LED lit.
41. Monitor level	1) Display f. : 21.100MHz MODE : USB MONI SW : ON MONI VR : 11 o'clock Meter : ALC MIC : AG (1kHz/10mV) MIC VR : ALC zone MAX STBY : SEND	Power meter  DM. SP Oscilloscope AF V.M	Rear panel	ANT  EXT. SP			Check	0.63V or more / 8Ω
42. Side tone	1) MODE : CW AF VR : Center KEY : Down MONI SW : OFF PITCH VR : OFF VOX SW : ON Rear panel ELECTRONIC KEY : OFF LINEAR AMP : ON	DM. SP AF V.M	Rear panel	EXT. SP	IF	VR5	Adjust to 0.2V/8Ω with key down.	0.18 ~ 0.22V
		ELE. KEY  Power meter f. counter		CW KEY  ANT Remote RTTY EXT. SP				

### Adjustment Points (Side)

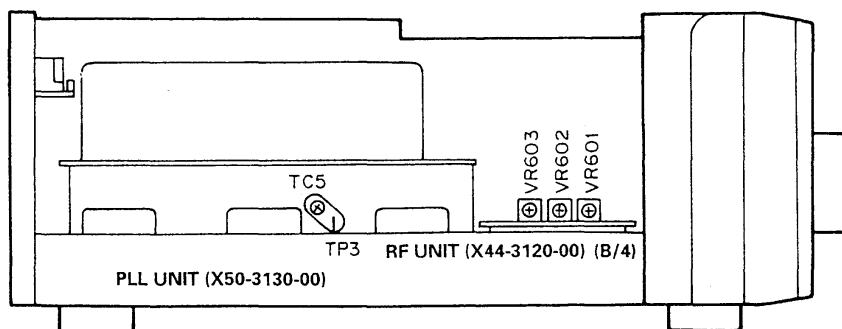

PLL UNIT (X50-3130-00)  
TC5 : Ref. OSC, 20MHz frequency

RF UNIT (X44-3120-00) (B/4)  
VR601 : FM MIC SENS  
VR602 : FM NARROW MAX DEV  
VR603 : FM MAX DEV  
L602,603 : NB

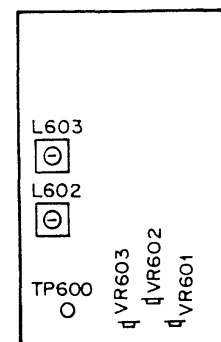

RF UNIT (X44-3120-00) (B/4)

Downloaded by   
  
Amateur Radio Directory

## ADJUSTMENT

### Adjustment Points (Upper)

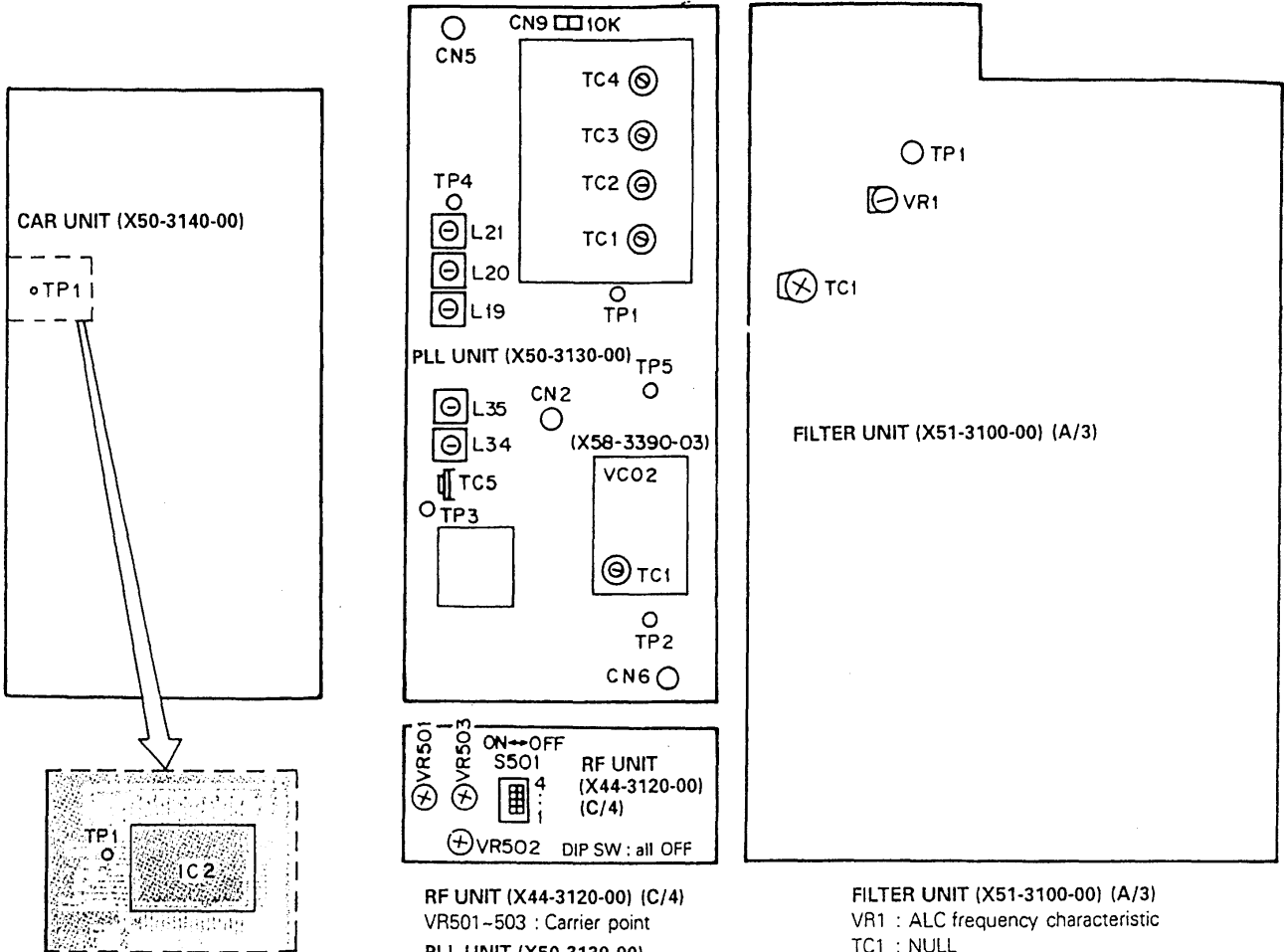

**RF UNIT (X44-3120-00) (C/4)**  
 VR501-503 : Carrier point  
**PLL UNIT (X50-3130-00)**  
 L19-21 : Peak level  
 L34,35 : Peak level  
 TC1 : VCO1  
 TC2 : VCO2  
 TC3 : VCO3  
 TC4 : VCO4

**VCO2 (X58-3390-03)**  
 TC1 : LO2 VCO

**FILTER UNIT (X51-3100-00) (A/3)**  
 VR1 : ALC frequency characteristic  
 TC1 : NULL

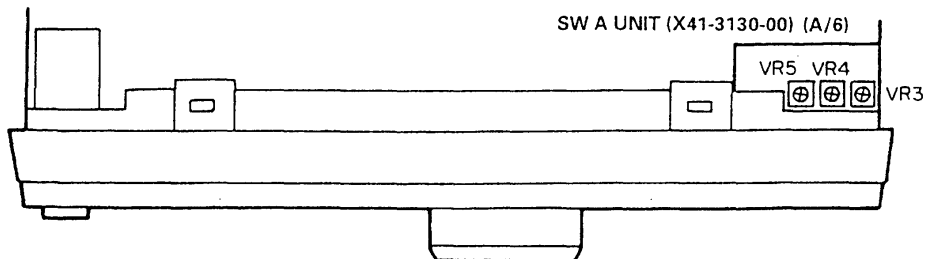

**SW A UNIT (X41-3130-00) (A/6)**  
 VR3-5 : Slope tune and RIT/XIT

# TS-850S

## ADJUSTMENT

### Adjustment Points (Lower)

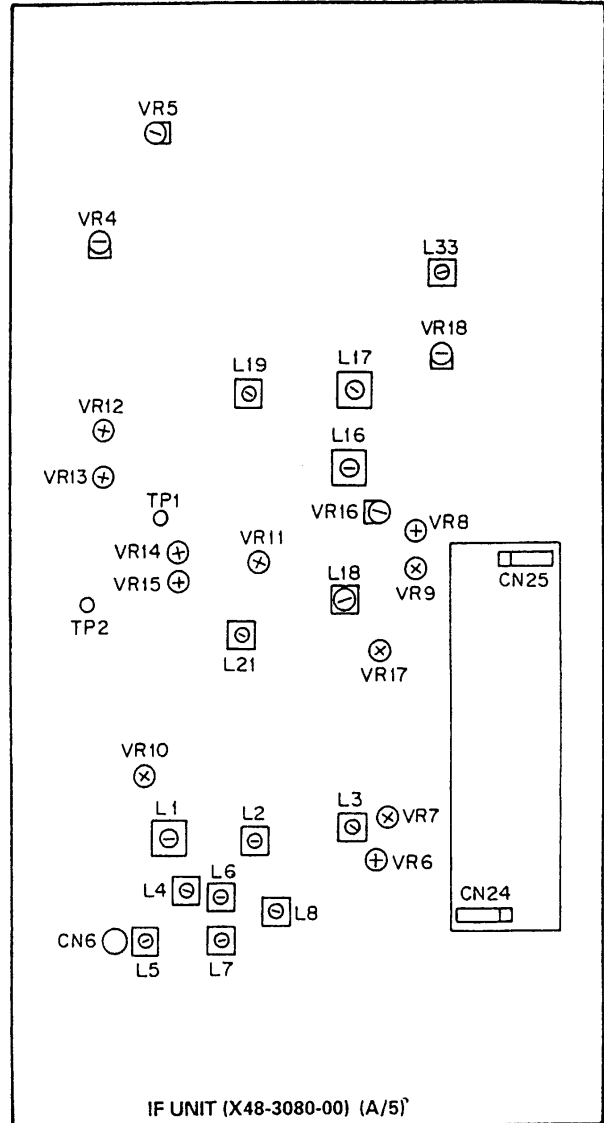
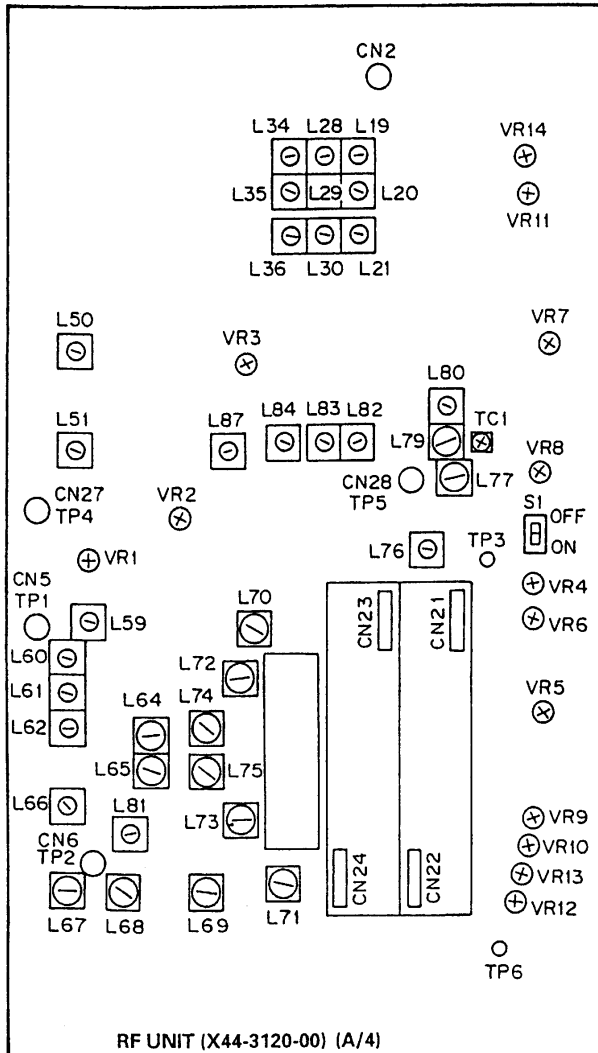

#### RF UNIT (X44-3120-00) (A/4)

- VR1 : MIX BAL
- VR2 : IF AMP
- VR3 : MIX balance, spurious
- VR4,6 : Power down
- VR5 : MIN power
- VR7 : ALC
- VR8 : SWR protection
- VR9 : Power meter
- VR10 : SWR meter
- VR11,12 : ALC meter
- VR13 : PROC amp and meter
- VR14 : ALC voltage
- TC1 : Power control tracking
- L19~21 : BPF (7~7.5MHz)
- L28~30 : BPF (14~14.5MHz)
- L34~36 : BPF (21~22MHz)
- L59~62 : MCF
- L64,65 : IF OUT 1
- L66~70,74,75,81 : RF amp and IF amp
- L77,79,80,82~84,87 : IF amp

#### IF UNIT (X48-3080-00) (A/5)

- VR4 : Beep tone
- VR5 : Side tone
- VR6 : PROC amp and meter
- VR8,9 : CAR suppression
- VR10 : FM S-meter
- VR11 : SSB squelch
- VR12,13 : S-meter and RX gain
- VR14,15 : AGC
- VR17 : S-meter and RX gain
- L1~4 : RF amp and IF amp
- L5~7 : IF amp
- L8 : PROC amp and meter
- L17 : S-meter and RX gain
- L17~19 : RF amp and IF amp
- L21 : FM gain

## TERMINAL FUNCTION

Connector No.	Terminal No.	Terminal Name	Terminal Function
<b>RF UNIT (X44-3120-00)</b>			
CN1	Coaxial	RAT	Reception signal input
CN2	Coaxial	DRV	Drive output
CN3	Coaxial	LO1	1st station transmission input ≅ 0dBm, 73.05~103.5MHz
CN4	Coaxial	LO2	2nd station transmission input ≅ +4dBm, 64.22MHz
CN5	Coaxial	TP1	TG terminal for X1 (73.05MHz MCF) adjustment, 0dBm
CN6	Coaxial	TP2	Spectrum analyzer terminal for X1 (73.05MHz MCF)
CN7	RCA		Cope out (8.83MHz)
CN8	1	14V	14V
	2	NBG	NB gate cut when high
	3	GND	GND
	4	GND	GND
	5	NBI	8.83MHz NB amplifier output
CN9	1	LC2	Relay
	2	LC1	Relay
	3	HC2	Relay
	4	HC1	Relay
	5	CEN2	Relay
	6	CEN1	Relay
	7	GND	GND
	8	NC	
	9	GND	GND
	10	RF1	Relay
	11	RF2	Relay
	12	RIT1	Relay
	13	RIT2	Relay
CN10	1	GND	GND
	2	NB2S	Relay
	3	8A	8V output for analog
	4	NB1S	Relay
	5	NB1V	Relay
	6	NTL	Relay
	7	NV2	Relay
	8	NCH	Relay
	9	-6	-6V output
	10	RITS	Relay
	11	XITS	Relay
	12	NC	
	13	LC1	Relay
	14	HC1	Relay
	15	RIT1	Relay
	16	8A	8V output for analog
	17	NB1V	Relay
	18	FSQ	Relay
	19	SSQ	Relay
	20	NV2	Relay
	21	GND	GND
CN11	1	GND	GND
	2	NC	
	3	ATT2	RF attenuation 12dB, through when 8V, 12dB when low
	4	ATT1	RF attenuation 6dB, through when 8V, 6dB when low
	5	GR	Outputs 12V when 22 to 30MHz BPF selected
	6	AGC	AGC voltage input
	7	FSQ	Relay

Connector No.	Terminal No.	Terminal Name	Terminal Function	
	8	SSQ	Relay	
	9	NB2S	Relay	
	10	NB1S	Relay	
	11	NCH	Relay	
	12	-6	-6V input	
	13	RF2	Relay	
	14	RF1	Relay	
	15	45D	} Output for IF unit 455kHz filter selection Active low	
	16	45C		
	17	45B		
	18	45A		
	19	PRV	Input terminal for compression meter	
	20	CKY	Keying line, radio signal output when high	
		21	PP3	} ALC threshold variation terminal during power control
		22	PP2	
		23	PP1	
		24	PG2	Gain control terminal during power control
		25	SS	To CN20 (remote) pin 3
		26	TXB	TXB (8V) input
27		RXB	RXB (8V) input	
28		8A	8V output for analog	
29		14AF	Relay	
30		DB	When changed over to 8V, forces Q29 on and prevents ALC keying	
CN12		1	SPO	Connected to CN20 (remote) pin 1
		2	GND	GND
CN13		1	8D	Relay
		2	14V	Relay
	3	PDE	Power down enable input, RF unit becomes 10W when low	
	4	TB0	Relay	
	5	TB1	Relay	
	6	TB2	Relay	
	7	TB3	Relay	
CN14	1	GND	Relay	
	2	LC2	Relay	
	3	HC2	Relay	
	4	CEN2	Relay	
	5	CEN1	Relay	
	6	NTL	Relay	
	7	RIT2	Relay	
	8	RITS	Relay	
	9	XITS	Relay	
	10	AIP	AIP control input, open : AIP on, GND : AIP off	
	11	TB3	Relay	
	12	TB2	Relay	
	13	TB1	Relay	
	14	TB0	Relay	
	15	PDE	PDE output	
	16	8D	Relay	
	17	NC		
	18	14V	Relay	

# TS-850S

## TERMINAL FUNCTION

Connector No.	Terminal No.	Terminal Name	Terminal Function																																																																																
CN15	1	RB2	IC1 : SN74LS145 control input																																																																																
	2	RB0	IC1 : SN74LS145 control input																																																																																
	3	RB1	IC1 : SN74LS145 control input																																																																																
	4	RB3	IC1 : SN74LS145 control input																																																																																
<table border="1"> <thead> <tr> <th>12pin RB3</th> <th>13pin RB2</th> <th>14pin RB1</th> <th>15pin RB0</th> <th>Output pin becomes low</th> <th>Band (MHz)</th> </tr> </thead> <tbody> <tr> <td>0</td> <td>0</td> <td>1</td> <td>0</td> <td>3</td> <td>~0.5</td> </tr> <tr> <td>0</td> <td>0</td> <td>0</td> <td>1</td> <td>2</td> <td>0.5~1.62 0.5~1.705 : K type</td> </tr> <tr> <td>0</td> <td>1</td> <td>0</td> <td>0</td> <td>5</td> <td>1.62~2.5 1.705~2.5 : K type</td> </tr> <tr> <td>1</td> <td>0</td> <td>0</td> <td>0</td> <td>10</td> <td>2.5~4</td> </tr> <tr> <td>1</td> <td>0</td> <td>1</td> <td>0</td> <td>*</td> <td>4~7</td> </tr> <tr> <td>0</td> <td>0</td> <td>0</td> <td>0</td> <td>1</td> <td>7~7.5</td> </tr> <tr> <td>0</td> <td>1</td> <td>1</td> <td>1</td> <td>9</td> <td>7.5~10.5</td> </tr> <tr> <td>1</td> <td>0</td> <td>1</td> <td>1</td> <td>*</td> <td>10.5~14</td> </tr> <tr> <td>0</td> <td>0</td> <td>1</td> <td>1</td> <td>4</td> <td>14~14.5</td> </tr> <tr> <td>1</td> <td>0</td> <td>0</td> <td>1</td> <td>11</td> <td>14.5~21</td> </tr> <tr> <td>0</td> <td>1</td> <td>1</td> <td>0</td> <td>7</td> <td>21~22</td> </tr> <tr> <td>0</td> <td>1</td> <td>0</td> <td>1</td> <td>6</td> <td>22~30</td> </tr> </tbody> </table>						12pin RB3	13pin RB2	14pin RB1	15pin RB0	Output pin becomes low	Band (MHz)	0	0	1	0	3	~0.5	0	0	0	1	2	0.5~1.62 0.5~1.705 : K type	0	1	0	0	5	1.62~2.5 1.705~2.5 : K type	1	0	0	0	10	2.5~4	1	0	1	0	*	4~7	0	0	0	0	1	7~7.5	0	1	1	1	9	7.5~10.5	1	0	1	1	*	10.5~14	0	0	1	1	4	14~14.5	1	0	0	1	11	14.5~21	0	1	1	0	7	21~22	0	1	0	1	6	22~30
12pin RB3	13pin RB2	14pin RB1	15pin RB0	Output pin becomes low	Band (MHz)																																																																														
0	0	1	0	3	~0.5																																																																														
0	0	0	1	2	0.5~1.62 0.5~1.705 : K type																																																																														
0	1	0	0	5	1.62~2.5 1.705~2.5 : K type																																																																														
1	0	0	0	10	2.5~4																																																																														
1	0	1	0	*	4~7																																																																														
0	0	0	0	1	7~7.5																																																																														
0	1	1	1	9	7.5~10.5																																																																														
1	0	1	1	*	10.5~14																																																																														
0	0	1	1	4	14~14.5																																																																														
1	0	0	1	11	14.5~21																																																																														
0	1	1	0	7	21~22																																																																														
0	1	0	1	6	22~30																																																																														
Each BPF is active low																																																																																			
Band of *																																																																																			
5	RBK	RX RF blanking input, when 8V is changed over, NB gate is shut off																																																																																	
6	FEN	IC3 : TC9174 control enable																																																																																	
7	FDA	IC3 : TC9174 control data																																																																																	
8	FCK	IC3 : TC9174 control clock																																																																																	
IC3 output and filter response																																																																																			
3	45D	6	8.83 L74,75	9	45A																																																																														
4	8.83 OP1	7	8.83 XF3	10	45B																																																																														
5	8.83 XF2	8	8.83 OP2	11	45C																																																																														
9	ALM	ALC meter output																																																																																	
10	CPM	Compression level output																																																																																	
11	VSRM	Reflected wave voltage output																																																																																	
12	VFSM	Forward wave voltage output																																																																																	
13	BPD	Control of power down according to band, active low																																																																																	
14	TPD	Control of power down according to destination, active low																																																																																	
15	ATPD	Power down control during AT tune, active low																																																																																	
16	ATAE	 ANT SW AT internal/external decision																																																																																	
17	EAT																																																																																		
18	PT	Final temperature protection output																																																																																	

Connector No.	Terminal No.	Terminal Name	Terminal Function
CN16	1	GND	GND
	2	RL	13V output during TX
	3	14V	13.8V input
	4	PT	Final temperature protection signal input
	5	VSR	Reflected wave detection voltage input
	6	VSF	Forward wave detection voltage input
	7	TXB	TXB (8V) output
	8	8A	8V input
	9	14AF	Relay
CN17	1	MON	TX monitor output, output 95mVrms (no-load) during SSB 100W output (when ALC started)
	2	GND	GND
CN18	Coaxial	MCAR	Monitor carrier input, 8.83MHz ± 1.5kHz, about 0dBm
CN19	Coaxial	TIF	8.83MHz TX IF input, TIF input -13.2dBm when CN2 DRV OUT is 10dBm (f = 14.1MHz)
CN20 7 pin DIN	1	SPO	CN12 pin 1
	2	C	Relay common terminal
	3	SS	CN11 pin 25
	4	NO	Relay normal open, Closed when TX
	5	NC	Relay normal close, Open when TX
	6	ALC	ALC input
	7	RL	13V output when TX
CN601	1	14V	DV 13V input
	2	NBG	NB blanking pulse output
	3	GND	NBG ground
	4	GND	NBI ground
	5	NBI	NB amplifier signal input
CN602	1	-6V	-6V output
	2	GND	GND
	3	NB1S	
	4	NB2S	
	5	8V	8V input
CN603	1	GND	GND
	2	NBW	NB2 width
	3	FMB	8V when FM mode, otherwise 0V
	4	NFB	8V when FM narrow mode, otherwise 0V
	5	NFMT	0V when FM mode, otherwise 8V
	6	FMD	FM modulation output (to PLL)
	7	GND	GND
	8	GND	GND
	9	FMI	FM modulation input (from IF)
<b>DIGITAL UNIT (X46-308X-XX)</b>			
CN1	1	14S	PLL, CAR unit 14V
	2	TU8C	TU-8 control
	3	TXB	Transmission +B
	4	8D	PLL, CAR unit 8V
	5	GND	GND
	6	VB3	VCO select signal
	7	VB2	VCO select signal
	8	VB1	VCO select signal

## TERMINAL FUNCTION









Connector No.	Terminal No.	Terminal Name	Terminal Function
	9	VBO	VCO select signal
	10	ULL	Unlock signal
	11	GND	GND
	12	PEL2	PLL, DDS control data enable
	13	PLE1	PLL, DDS control data enable
	14	PCK	PLL, DDS control data clock
	15	PDA	PLL, DDS control data
	16	DLE4	PLL, DDS control data enable
	17	DLE3	PLL, DDS control data enable
	18	DLE2	PLL, DDS control data enable
	19	DLE1	PLL, DDS control data enable
	20	TOC	Repeater tone control
	21	ABSL	DDS register select
	22	GND	GND
	23	CASL	DDS register select
	24	GND	GND
CN2	1	DOT	Dot input
	2	DASH	Dash input
	3	EKS	Electronic keyer select swiwtch
	4	KEY	Key output
	5	TXI	TX inhibit signal
	6	MUP	MIC up switch
	7	MDN	MIC down switch
	8	TXB	Transmission +B
	9	CWC	Mode select signal
	10	RYC	Mode select signal
	11	SSBC	Mode select signal
	12	AMC	Mode select signal
	13	FMC	Mode select signal
	14	ATA	AT AUTO/THROUGH switch
	15	SS	Transmit/receive control signal
	16	ATS	AT start switch
	17	VOX	VOX switch
	18	FULL	FULL/SEMI switch
	19	AIPS	AIP switch
	20	DIM	Dimmer switch
	21	KS1	Electronic keyer speed control
	22	KS2	Electronic keyer speed control
	23	PRS	Processor switch
	24	SM	Signal meter voltage
	25	BEEP	Buzzer output
	26	ABK	AF blanking
	27	RDC	RX DSP select
	28	TDC	TX DSP select
CN3	1	5V	5V
	2	EN1	Main encoder pulse input
	3	EN2	main encoder pulse input
	4	GND	GND
CN4	1	5V	5V
	2	8V	8V
	3	LEN1	LCD control data enable
	4	LEN2	LCD control data enable
	5	LDA	LCD control data
	6	LCK	LCD control data clock
	7	BLK	LCD all light off
	8	INH	LCD all light off
	9	DIM	Dimmer switch
	10	GND	GND
CN5	1	GND	GND
	2	5V	5V
	3	ATL	AT LED control
	4	AIL	AIP LED control
	5	MHL	1MHz LED control

Connector No.	Terminal No.	Terminal Name	Terminal Function
	6	TXL	TX LED control
	7	NTL	Notch LED control
	8	RXAL	Function LED control
	9	RXBL	Function LED control
	10	RXML	Function LED control
	11	TXAL	Function LED control
	12	TXBL	Function LED control
	13	TXML	Function LED control
	14	S0	Key matrix output
	15	S1	Key matrix output
	16	S2	Key matrix output
	17	S3	Key matrix output
	18	S4	Key matrix output
	19	S5	Key matrix output
	20	K5	Key matrix input
	21	K4	Key matrix input
	22	K3	Key matrix input
	23	K2	Key matrix input
	24	K1	Key matrix input
	25	K0	Key matrix input
CN6	1	PT	Temperature protection input
	2	EAT	AT select switch
	3	ATAE	ATA control
	4	ATPD	Power down control
	5	TPD	Power down control
	6	BPD	Power down control
	7	VFSM	RF meter voltage
	8	VSRM	Reflector voltage
	9	CPM	Processor meter voltage
	10	ALM	ALC meter voltage
	11	FCK	Filter select data clock
	12	FDA	Fiiter select data
	13	FEN	Filter select data enable
	14	RBK	RF blanking
	15	RB3	RX BPF band data
	16	RB1	RX BPF band data
	17	RB0	RX BPF band data
	18	RB2	RX BPF band data
CN7	1	14V	14V
	2	NC	
	3	8V	8V
	4	PDE	Final decision
	5	TB0	TX LPF band data
	6	TB1	TX LPF band data
	7	TB2	TX LPF band data
	8	TB3	TX LPF band data
	9	AIP	AIP control
	10	XITS	XIT switch
	11	RITS	RIT switch
	12	RIT2	RIT/XIT control
	13	NTL	Notch LED
	14	CEN1	Click encoder pulse
	15	CEN2	Click encoder pulse
	16	HC2	Slope tune high cut volume
	17	LC1	Slope tune low cut volume
	18	GND	GND
CN8	1	GND	GND
	2	POD1	AT variable condenser position volume
	3	POD2	AT variable condenser position volume
	4	VRE	5V
	5	PR11	Motor rotate direction control
	6	PR12	Motor rotate direction control
	7	PR21	Motor rotate direction control

# TS-850S













## TERMINAL FUNCTION

Connector No.	Terminal No.	Terminal Name	Terminal Function
	8	PR22	Motor rotate direction control
	9	APRE	Motor control select
	10	SPED	Motor speed control
	11	ATE	AT connect decision
	12	ATA	AT AUTO/THROUGH
CN9	1	GND	GND
	2	CRW2	CAR point tuned volume
	3	CRV2	CAR point tuned volume
	4	CRL2	CAR point tuned volume
	5	VRE	5V
	6	DPS4	Option filter installed switch
	7	DPS3	Option filter installed switch
	8	DPS2	Option filter installed switch
	9	DPS1	Option filter installed switch
	10	SD	VS-2 control data
	11	SCK	VS-2 control data clock
	12	SBSY	VS-2 busy
	13	STR	VS-2 synthesize control
	14	STBY	DRU-1 stand by control
	15	ACL	DRU-1 reset
	16	WR	DRU-1 write
	17	RD	DRU-1 read
	18	VOB	DRU-1 voice synthesize signal switch
	19	VOA	DRU-1 voice synthesize signal switch
	20	5V	5V
	21	D8	DRU-1 control data
	22	D4	DRU-1 control data
	23	D2	DRU-1 control data
	24	D1	DRU-1 control data
	25	VCK	DRU-1 installed signal
	26	GND	GND
CN10	1	TT	External AT control
	2	TS	External AT control
	3	DGD	Ground
	4	RTS	Personal computer interface
	5	CTS	Personal computer interface
	6	RXD	Personal computer interface
	7	TXD	Personal computer interface
	8	DBC	DSP control input
CN12	1	RMC2	Wired remoto control voltage
	2	DG	Ground
<b>IF UNIT (X48-3080-00)</b>			
CN1	1	NC	
	2	ATA	Antenna tuner AUTO/THROUGH switch, GND when AUTO
	3	SS	Stand by switch, TX when GND
	4	ATS	Antenna tuner start/stop, operation starts upon lowering
	5	GND	GND
	6	NC	
	7	VOX	VOX switch, open at VOX on
	8	FULL	FULL/SEMI switch, GND when FULL
	9	AIPS	AIP switch, operates upon lowering
	10	DIM	Dimmer switch, GND at dimmer on
	11	HIBST	High boost switch. Creates the peak at high pass (about 2.5kHz) of the microphone amplifier
CN2	12	GND	GND
	1	8A	8V for analog
	2	AGO	AGC switch OFF
	3	SLOW	AGC switch SLOW
	4	MID	AGC switch MID

Connector No.	Terminal No.	Terminal Name	Terminal Function
	5	KS1	Speed VR 1 of the built-in electronic keyer 
	6	KS2	Speed VR 2 of the built-in electronic keyer 
	7	CAR2	Carrier volume 2 
	8	GND	GND
	9	NC	
	10	SSBB	8V when SSB
	11	PROS	Speech processor switch, on : 8V (SSB)
	12	MONS	Monitor switch, off : 8V
	13	8A	8V for analog
	14	ATT1	Attenuator switch for 6dB, on : open
	15	ATT2	Attenuator switch for 12dB, on : open
	16	NC	
	17	GND	GND
	18	PRO2	Speech processor gain VR 2 
	19	8A	8V for analog
	20	PG2	Power control gain setting VR 2 
	21	PP1	Power control VR 1 
	22	PP2	Power control VR 2 
	23	PP3	Power control VR 3 
	24	NC	
	25	8A	8V for analog
	26	NB2S	NB2 switch
	27	NB1S	NB1 switch
	28	GND	GND
	29	-6	-6V
CN3	1	DOT	Dot input for built-in electronic keyer
	2	DASH	Dash input for built-in electronic keyer
	3	EKS	Internal/external electronic keyer select
	4	KEY	KEY line
	5	TXI	TX inhibit, inhibit when low
	6	UP	MIC up
	7	DN	MIC down
	8	TXB	8V during transmission
	9	CWC	GND when CW mode
	10	RYC	GND when FSK mode
	11	SSBC	GND when SSB mode
	12	AMC	GND when AM mode
	13	FMC	GND when FM mode
	14	ATA	Antenna tuner AUTO/THROUGH switch, GND when AUTO
	15	SS	Stand by switch, TX when GND
	16	ATS	Antenna tuner start/stop, operation starts upon lowering
	17	VOX	VOX switch, open at VOX on
	18	FULL	FULL/SEMI switch, GND when FULL
	19	AIPS	AIP switch, operates upon lowering
	20	DIM	Dimmer switch, GND at dimmer on
	21	KS1	Speed VR 1 of the built-in electronic keyer
	22	KS2	Speed VR 2 of the built-in electronic keyer
	23	PROS	Speech processor switch, on : 8V (SSB)
	24	SM	S-meter voltage output
	25	BEEP	Beep signal input
	26	ABK	RX audio mute signal



## TERMINAL FUNCTION

Connector No.	Terminal No.	Terminal Name	Terminal Function
	27	RDC	Low when DSP reception is connected
	28	TDC	Low when DSP transmission is connected
CN4	1	GND	GND
	2	NC	
	3	ATT2	Attenuator switch for 12dB, on : open
	4	ATT1	Attenuator switch for 6dB, on : open
	5	28GD	28MHz gain down signal, high when 28MHz
	6	AGC	AGC line
	7	FSQ	FM squelch setting voltage
	8	SSQ	FM squelch setting voltage
	9	NB2S	NB2 switch
	10	NB1S	NB1 switch
	11	NCH	Notch setting voltage
	12	-6	-6V
	13	RF2	RF gain VR 2 
	14	RF1	RF gain VR 1 
	15	45D	12kHz filter select signal
	16	45C	6kHz filter select signal
	17	45B	2.7kHz filter select signal
	18	45A	Option CW filter select signal
	19	PRV	Compression meter voltage
	20	CKY	Keying signal
	21	PP3	Power control VR 3 
	22	PP2	Power control VR 2 
	23	PP1	Power control VR 1 
	24	PG2	Power control gain setting VR 2 
	25	SS	Stand by switch, TX when GND
	26	TXB	8V during transmission
	27	RXB	8V during reception
	28	8A	8V for analog
	29	14AF	13.8V for audio amplifier
	30	TDB	8V when TDC is low
CN5	Coaxial	RIF	RX IF input (8.83MHz)
CN6	Coaxial	RIF	TX IF output (8.83MHz)
CN7	Coaxial	LO3	Local 3 input (8.375MHz)
CN8	1	DTIF	DSP transmission input
	2	GND	GND
CN9	1	CAR	Carrier input
	2	GND	GND
CN10	1	DRIF	DSP reception output
	2	GND	GND
CN11	1	AV1	AF VR 1 
	2	AV2	AF VR 2 
	3	GND	AF VR 3 
	4	NC	
CN12	1	SPO	Speaker output for remote jack
	2	GND	GND
CN13	1	PH1	Phone jack output
	2	PH2	Phone jack through
	3	GND	GND
CN14	1	GND	GND
	2	SP	Internal speaker output
CN15	1	STON	Side-tone input
	2	GND	GND
CN16	1	MONI	Monitor detection input
	2	GND	GND
CN17	1	MON1	Monitor VR 1 
	2	GND	Monitor VR 3 
	3	MON2	Monitor VR 2 

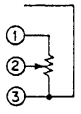
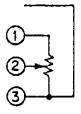
Connector No.	Terminal No.	Terminal Name	Terminal Function
CN18	1	NC	
	2	DRU10	DRU-1 monitor input
	3	GND	GND
	4	VS2	VS-2 input
	5	NC	
CN19	1	GND	GND
	2	DAF2	RX AF input for DSP
	3	GND	GND
	4	DAF1	RX AF output for DSP
	5	CKY	CKY for DSP
	6	TXB	TXB for DSP
	7	MAG	MIC amplifier GND for DSP
	8	MAO	MIC amplifier output for DSP
CN20	1	MAG	MIC amplifier ground
	2	MAO	MIC amplifier output 
	3	MV2	MIC gain VR 2
	4	MVG	MIC gain VR 3
	5	PV2	Processor processor VR 2 
	6	NC	
CN21	1	GND	GND
	2	VI	Input/output for DRU-1
CN22	1	MIC	MIC connector
	2	MICG	GND for MIC
	3	8M	8V output for MIC connector
	4	SS	Stand by switch for MIC
	5	UP	Up switch for MIC
	6	DN	Down switch for MIC
CN23	1	FMN	FM narrow signal
	2	MUTE	"H" except when FM transmission
	3	FMB	8V when FM mode
	4	MAG	FM MIC amplifier GND
	5	MAO	FM MIC amplifier output
J1	1	NC	
	2	NC	
	3	ANO	RX audio output
	4	ANG	RX audio output GND
	5	PSQ	GND when squelch open, open when squelch closed
	6	SM	S-meter voltage output
	7	NC	
	8	GND	GND
	9	PKS	Stand by switch when ANI input used
	10	NC	
	11	ANI	TX input
	12	ANIG	TX input GND
	13	SS	Stand by switch
J2		EXT. SP	External speaker jack
J3		KEY	Key jack
<b>PLL UNIT (X50-3130-00)</b>			
CN1		DLO1	DDS1 output, 4.45~4.95MHz, -17dBm
CN2		20M	Reference signal output for CAR unit, 20MHz, -6dBm
CN3	1	TXB	Transmission +B
	2	8D	8V
	3	GND	GND
	4	PCK	DDS data clock
	5	PDA	DDS data
	6	DLE4	DDS enable, IC3

# TS-850S

## TERMINAL FUNCTION

Connector No.	Terminal No.	Terminal Name	Terminal Function	
	7	DLE3	DDS enable, IC2	
	8	DLE2	DDS enable, IC4	
	9	DLE1	DDS enable, IC1	
	10	TOC	Sub-tone ON/OFF control	
	11	ABSL	DDS data select, IC1 and IC3	
	12	CASL	DDS data select, IC2 and IC4	
CN4	1	14S	Power line, 10~14V	
	2	TU8C	TU-8 control line, active low	
	3	TXB	TXB	
	4	8D	8V for digital	
	5	GND	GND	
	6	VB3	VCO select line, } active high	
	7	VB2		21.5~30MHz
	8	VB1		14.5~21.49999
	9	VB0		7.5~14.49999
	10	UNL	Unlock detection output	
	11	GND	GND	
	12	PLE2	PLL2 (VCO2, LO2) enable	
	13	PLE1	PLL1 (LO1) enable	
	14	PCK	PLL clock	
	15	PDA	PLL data	
	16	DLE4	DDS enable	
	17	DLE3	DDS enable	
	18	DLE2	DDS enable	
	19	DLE1	DDS enable	
	20	TOC	Sub-tone ON/OFF control	
	21	ABSL	DDS data select, IC1 and IC3	
	22	GND	GND	
	23	CASL	DDS data select, IC2 and IC4	
	24	GND	GND	
CN5		LO1	LO1 output, 73.08~103.05MHz, 0dBm	
CN6		LO2	LO2 output, 64.2200MHz, 5dBm	
CN7	1	GND	GND	
	2	TON	Option TU-8 AF output	
	3	TOB	Option TU-8 power supply	
CN8	1	GND	GND	
	2	FMD	FM modulation input	
CN9	1	GND	GND	
	2	10K	External DSP reference signal 10kHz, 200mVp-p (600Ω)	
<b>CAR UNIT (X50-3140-00)</b>				
CN1	1	TXB	Transmission power +B	
	2	8D	8V	
	3	GND	GND	
	4	PCK	DDS data clock	
	5	PDA	DDS data	
	6	DLE4	DDS enable, IC3	
	7	DLE3	DDS enable, IC2	
	8	DLE2	DDS enable, IC4	
	9	DLE1	DDS enable, IC1	
	10	TOC	Sub-tone ON/OFF control	
	11	ABSL	DDS data select, IC1 and IC3	
	12	CASL	DDS data select, IC2 and IC4	
CN2		DLO1	Main local : 1Hz step	
CN3		20M	Reference 20MHz input	
CN4		LO3	Local : 8.375MHz	
CN5		MCAR	Monitor carrier : 8.83MHz	
CN6	1	CAR	Carrier : 455kHz	
	2	GND	GND	
	3	GND	GND	
	4	RTK	RTTY keyer input	

Connector No.	Terminal No.	Terminal Name	Terminal Function
CN7		CTON	Tone for CW side-tone
<b>FILTER UNIT (X51-3100-00)</b>			
CN1		PO	Filter input
CN2		ATI	AT input
CN3	1	8V	+8V
	2	GND	GND
	3	GND	GND
	4	14S	+14V
	5	14S	+14V
	6	LP0	Filter selection 4-digit BCD
	7	LP1	Filter selection 4-digit BCD
	8	LP2	Filter selection 4-digit BCD
	9	LP3	Filter selection 4-digit BCD
	10	RL	+14V during transmission
	11	VSF	Forward wave detection
	12	VSR	Reflected wave detection
CN4	1	GND	GND
	2	14S	+14V
	3	GND	GND
	4	10A	7.5~10.5MHz
	5	28A	24.5~30MHz
	6	25A	21.5~24.5MHz
	7	7A	4~7.5MHz
	8	21A	18.5~21.5MHz
	9	18A	14.5~18.5MHz
	10	4A	2.5~4.0MHz
	11	14A	10.5~14.5MHz
			} AT coil tap band data
CN5		AT2	AT output
CN6		RAT	Reception antenna
CN7	1	GND	GND
	2	RL	+14V during transmission
	3	14S	+14V
CN8	1	TT	Tuning control
	2	TS	Tuning control
CN9	1	DBC	DSP connection
	2	GND	GND
	3	DGD	Digital GND
	4	TXD	TX data output
	5	RXD	RX data input
	6	GND	GND
	7	CTS	Transmittable input
	8	RTS	TX request output
	9	GND	GND
	10	GND	GND
	11	TS	Tuning control
	12	TT	Tuning control
CN10	1	TXB	+12V during transmission
	2	DAF1	DSP audio output
	3	GND	GND
	4	CKY	Keying control
	5	DAF2	DSP audio input
	6	GND	GND
	7	MAG	MIC amplifier GND
	8	MAO	MIC amplifier output
CN11	1	10K	10kHz output
	2	GND	GND
CN12		RTK	RTTY keying
CN13		CAL	Calibration input
CN14		TP1	VSR voltage detection

## TERMINAL FUNCTION

Connector No.	Terminal No.	Terminal Name	Terminal Function
CN15	1	RMC	Remote control signal
	2	DG	GND
	3	GND	GND
W1	1	14S	+14V
	2	RL	+14V during transmission
	3	GND	GND
J1	1	DAF1	DSP audio output
	2	GND	GND
	3	DAF2	DSP audio input
	4	GND	GND
	5	DBC	DSP connection
	6	RTK	RTTY keying
	7	CKY	Keying control
	8	GND	GND
	9	GND	GND
	10	10K	10kHz output
	11	MAO	MIC amplifier output
	12	MAG	MIC amplifier GND
	13	TXB	+12V during transmission
J2	1	DGD	Digital GDN
	2	TXD	TX data output
	3	RXD	RX data input
	4	CTS	Transmittable input
	5	RTS	TX request output
	6	NC	
J3		RMC	Remote control

Connector No.	Terminal No.	Terminal Name	Terminal Function
<b>AT UNIT (X53-3340-00)</b>			
CN1		AT1	AT input
CN2		AT2	AT output
CN3	1	VRE	+5V reference for A/D
	2	POD2	VC2 position detection, VR101 output
	3	GND	GND
	4	POD1	VC1 position detection, VR102 output
CN4	1	NC	
	2	M2-	Motor 2 drive -
	3	M2+	Motor 2 drive +
	4	M1-	Motor 1 drive -
	5	M1+	Motor 1 drive +
CN5	1	NC	
	2	F15	Power line, 11~14V
	3	GND	GND
CN6	1	ATA	Make for AT through/on relay, on when low
	2	NC	
CN7	1	ATG	GND for discriminating that AT is connected to microcomputer
	2	SPED	Motor speed control pulse
	3	APRE	Control selection, high : preset type, low : auto tuning
	4	VRE	+5V reference for A/D
	5	PR22	Motor 2 control signal
	6	PR21	Motor 2 control signal
	7	POD2	VC2 position detection
	8	PR12	Motor 1 control signal
	9	PR11	Motor 1 control signal
	10	POD1	VC1 position detection
	11	GND	GND

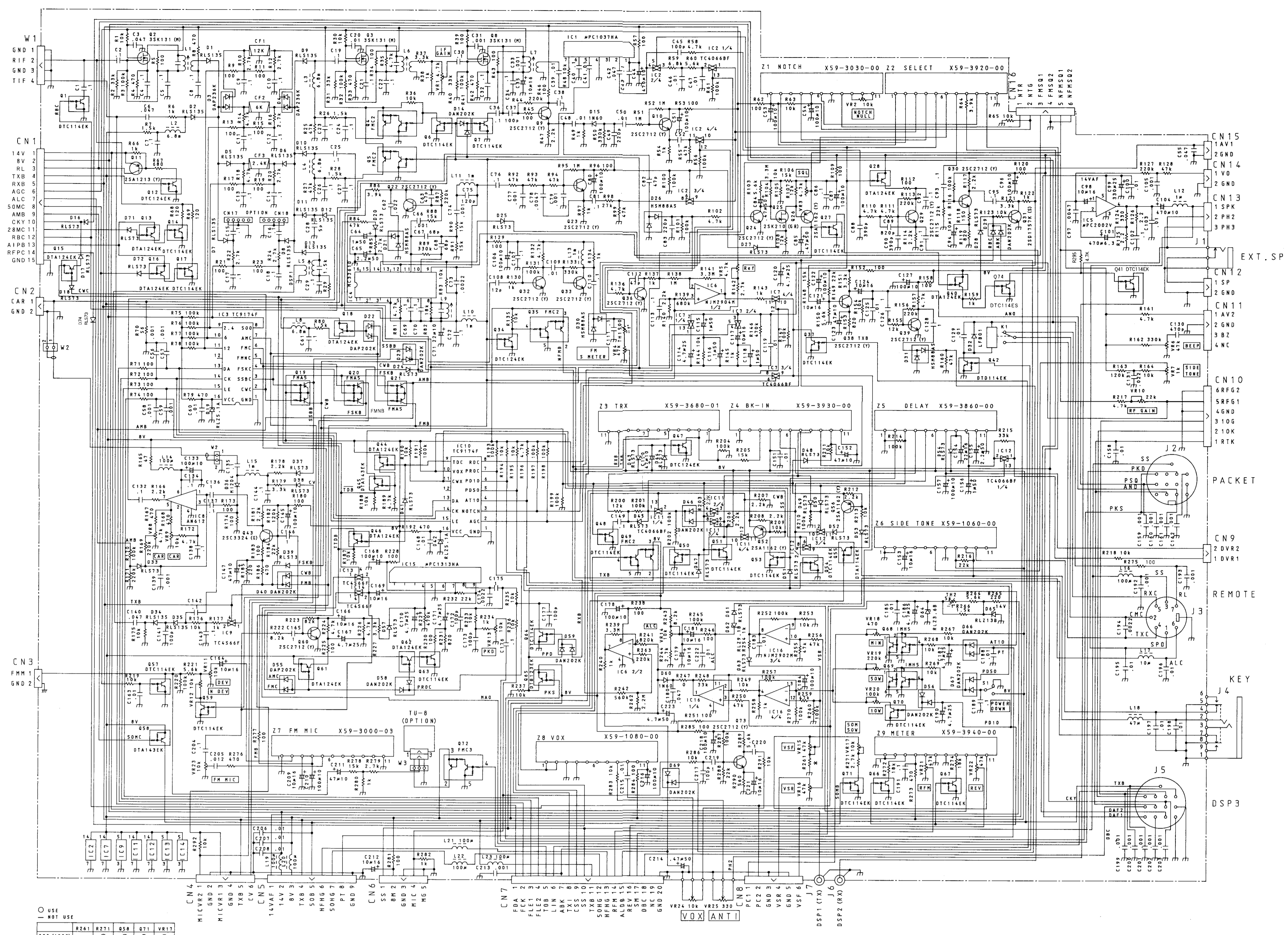

RESISTOR	VALUE	RESISTOR	VALUE
R1	100Ω	R51	100kΩ
R2	100Ω	R52	100kΩ
R3	100Ω	R53	100kΩ
R4	100Ω	R54	100kΩ
R5	100Ω	R55	100kΩ
R6	100Ω	R56	100kΩ
R7	100Ω	R57	100kΩ
R8	100Ω	R58	100kΩ
R9	100Ω	R59	100kΩ
R10	100Ω	R60	100kΩ

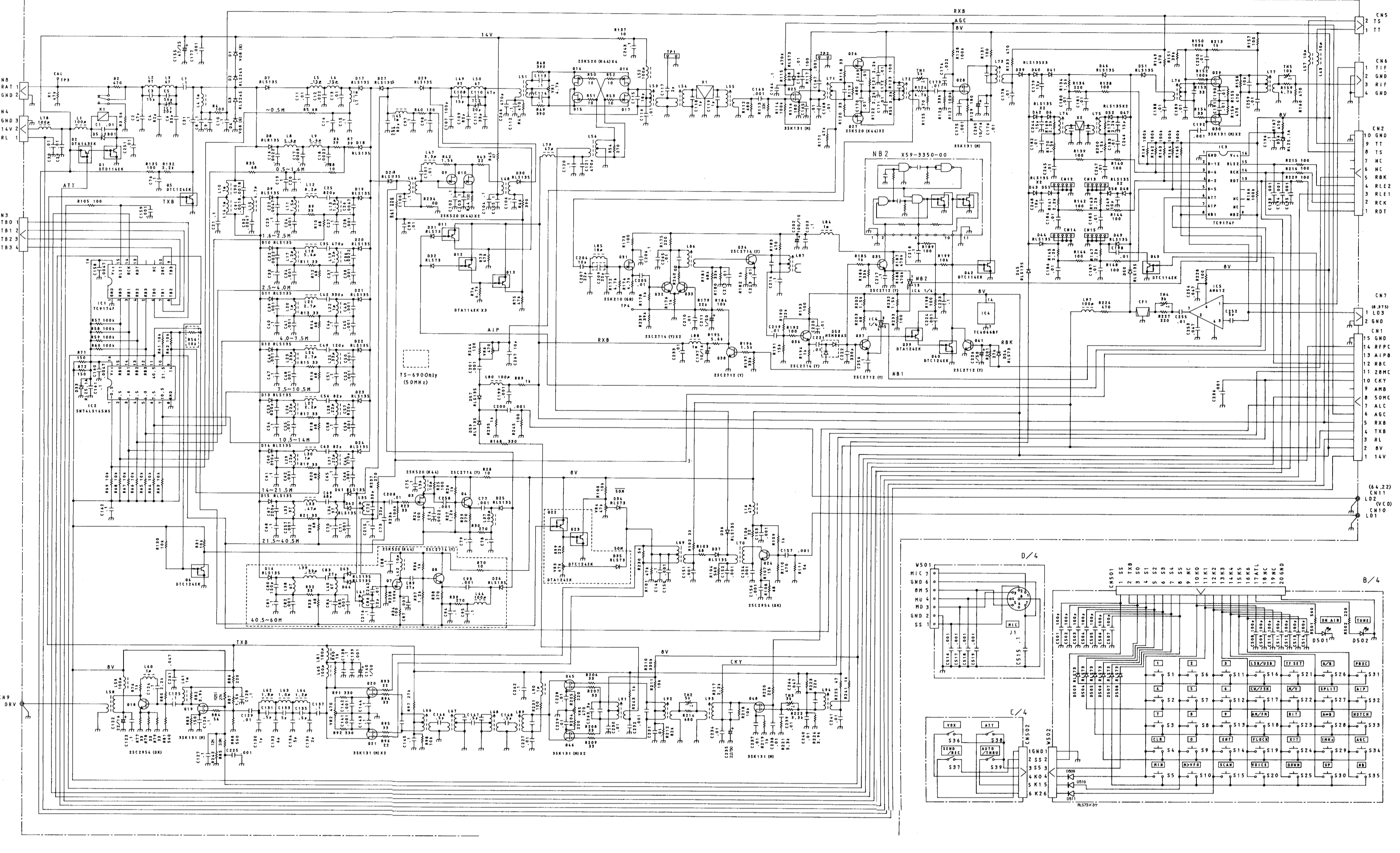

RESISTOR	VALUE	RESISTOR	VALUE
R1	100Ω	R51	100kΩ
R2	100Ω	R52	100kΩ
R3	100Ω	R53	100kΩ
R4	100Ω	R54	100kΩ
R5	100Ω	R55	100kΩ
R6	100Ω	R56	100kΩ
R7	100Ω	R57	100kΩ
R8	100Ω	R58	100kΩ
R9	100Ω	R59	100kΩ
R10	100Ω	R60	100kΩ

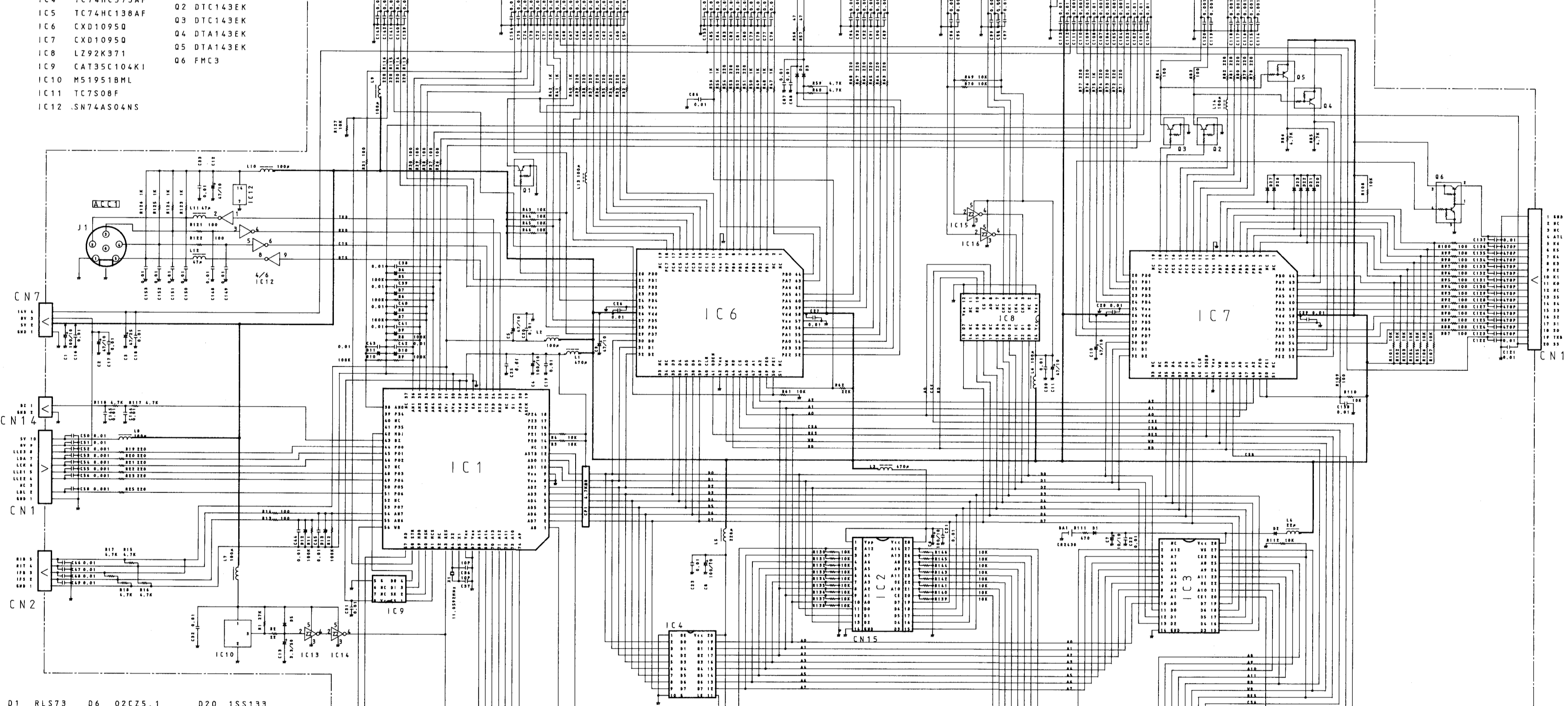

RESISTOR	VALUE	RESISTOR	VALUE
R1	100Ω	R51	100kΩ
R2	100Ω	R52	100kΩ
R3	100Ω	R53	100kΩ
R4	100Ω	R54	100kΩ
R5	100Ω	R55	100kΩ
R6	100Ω	R56	100kΩ
R7	100Ω	R57	100kΩ
R8	100Ω	R58	100kΩ
R9	100Ω	R59	100kΩ
R10	100Ω	R60	100kΩ

SCHEMATIC DIAGRAM

