

THERMAL FLUID
HEATERS

HI-R-TEMP[®] THERMAL FLUID HEATERS INSTALLATION MANUAL

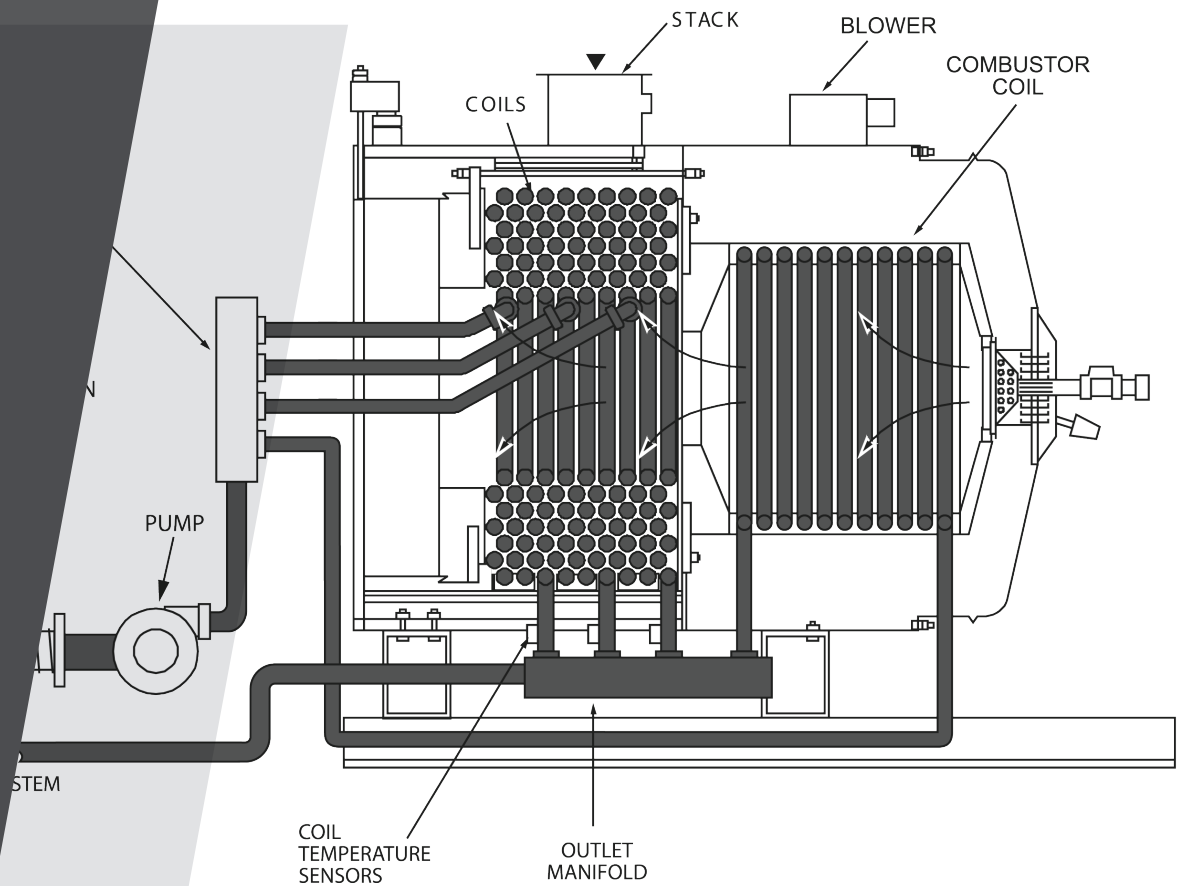

VAPOR POWER INTERNATIONAL

551 S. County Line Rd. Franklin Park, IL 60131

P: 630.694.5500 F: 630.694.2230 VaporPower.com

TABLE OF CONTENTS

<u>SECTION NO.</u>	<u>TITLE</u>	<u>PAGE NO.</u>
1	GENERAL	3
2	UNLOADING	3
3	INSTALLATION	4
4	MOUNTING	5
5	CLEARANCE	5
6	COMBUSTION AIR REQUIREMENTS	6
7	STACK INSTALLATION	7
8	FUEL SUPPLY	10
8.1	Oil and Combination Fired Heaters	10
8.2	Gas Fired Heaters	13
9	PILOT BURNER GAS REQUIREMENTS	16
10	COMPRESSED AIR REQUIREMENTS	16
11	POWER SUPPLY REQUIREMENTS	17
12	CIRCULATING PUMP	18
13	SYSTEM PIPING (GENERAL)	19
13.5	Flanged Connection	20
13.6	Valving	21
13.7	Strainer and Filter	21
13.8	Expansion Tank Installation	22
13.9	System Pressure Control Valve (PCV)	25
15	TESTING SYSTEM FOR LEAKAGE	26
16	CLEANING THE SYSTEM	27
17	SYSTEM FILLING	27
18	FIRE PROTECTION	28
19	NEW UNIT STORAGE	28
	TYPICAL HEATER ROOM LAYOUT SINGLE INSTALLATION NOTES ONLY – FIGURE 15 REMOVED	29

1. GENERAL

1.1 A well planned installation is essential to achieve maximum efficiency, ease of maintenance, and extended service life from the heater, the heat transfer fluid and other system components.

1.1.1 The study of this installation Manual is considered IMPORTANT. Feel free to consult with a Vapor Power Sales Engineer on the following:

- a. Your installation drawings.
- b. Prestart-up installation inspection by a Vapor Power Service Engineer.
- c. Testing for system leaks.
- d. Filling the system.
- e. Purging of air from main loop alone and one loop (user) at a time.
- f. Setting or adjusting excess pressure control, differential pressure switch (flow) and pressure control valve (PCV).
- g. Firing heater and checking setting of the high fire release switch.
- h. Boiling out system to eliminate air, water, and light ends of the fluid from main loop alone and one loop (user) at a time.

1.2 This manual contains many helpful suggestions and recommendations for the proper installation of piping, wiring, stack arrangements, and various other factors that should be considered for a good installation.

1.3 Figure 15, illustrates a typical heater installation.

2. UNLOADING

2.1 Vapor Power recommends that experienced riggers handle the heater when it is unloaded from its carrier and moved to the site of installation. Be sure the equipment to be used can handle the weight of the heater. Usually a lift truck of adequate capacity, if available, is all that is necessary to handle the heater.

2.2 Table 1 lists the various basic Liquid Phase Heater models, their approximate maximum shipping weights, and their approximate floor loadings. These weights do not include auxiliary equipment.

2.3 Vapor Power cannot be responsible for damage caused in transit. Uncrate your heater when you receive it. Make any claims for damages to the carrier within the allowable time limit. Inspect the heater again after the riggers have moved it into place so that any damage claims may be filed against them at this time. Notify Vapor Power immediately should a part be damaged so that a replacement can be obtained before start-up.

IN ORDER TO PREVENT DAMAGE THAT MAY OCCUR FROM FREEZING, STORE UNITS INDOORS IN A HEATED ENVIRONMENT WHERE TEMPERATURES REMAIN ABOVE FREEZING AT ALL TIMES.

APPROXIMATE WEIGHT

HEATER MODEL	FLOOR LOAD (LBS/SQ. FT.)	SHIPPING WEIGHT (LBS. APPROXIMATE)
4234	127	1,800
4238	113	2,300
4242	131	3,000
25	125	4,900
35	154	6,500
50	160	7,800
65	215	11,600
85	200	12,700
100	230	15,600
120	220	17,900
140	212	18,650
160	224	21,000
180	229	23,000
200	262	35,000

Table 1

2.4 When slings are used, use heavy pipe or solid bars inserted through the holes in the mounting skids. Use spreader bars to prevent damage to the heater when lifting.

2.5 When moving the heater or raising it, be sure slings or jacks are not attached to the piping, or apply stress to the heater casing, controls, or accessories. Never raise the heater from one corner only, be sure it is always raised evenly.

3. INSTALLATION

3.1 Consult with a Vapor Power Sales Engineer and review this manual, for proper installation of heater.

3.2 Local authorities and your insurance company have jurisdiction over the installation of the heater, related equipment and stack. They should be consulted before the installation is started, and any permits needed should be obtained.

3.3 Many insurance companies require heater installations to be in accordance with the National Fire Protection Association. Listed below are two of the applicable standards.

3.3.1 Standards for "Gas Piping and Gas Appliances in Buildings" are contained in pamphlet NFPA No. 54.

3.3.2 Standards for "Installation of Oil Burning Equipment" are contained in pamphlet NFPA No. 31.

3.3.3 Other applicable standards should be consulted as necessary. These may be determined by contacting the NFPA office in Boston, MA 02110.

3.4 Consult your gas company regarding inlet gas pressure and capacity (CFM).

4. MOUNTING

4.1 No special masonry support is necessary except to keep the heater level. The heater is mounted on a heavy structural steel base but MUST BE LEVEL. If necessary, level the heater with shims and grout with stiff cement. Make sure the heater base is in contact with floor at all points. The floor must be of noncombustible material. The floor loading will be approximately as indicated in Table 1. Check your building specifications for the permissible floor loading.

4.2 Secure the heater with bolts through the mounting holes in the base. Bolts should be no larger than 3/4" diameter to allow for production tolerances.

4.3 Some customers prefer to elevate the heater as additional protection from drainage or to facilitate installation. A concrete pad (see Figure 1) approximately four inches thick is the usual practice in such instances.

5. CLEARANCE

5.1 There must be sufficient clearance around and above the heater for convenient servicing, and to meet code minimum requirements. Install the heater using the recommended dimensions given in Table 2 as illustrated in Figure 1. These are the recommended minimum dimensions for a reasonable service area.

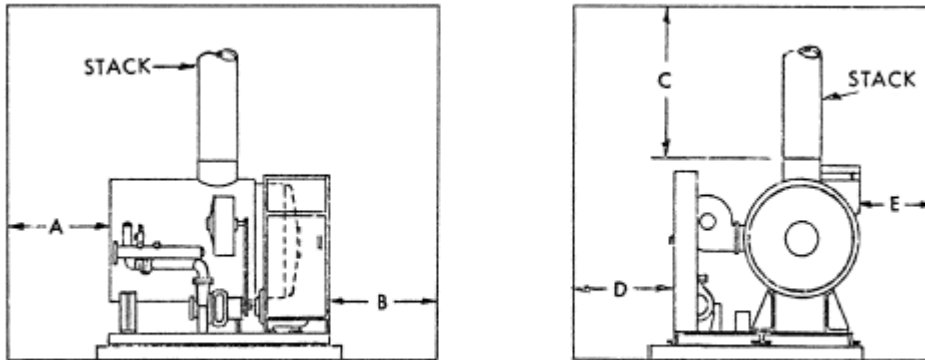

Figure 1, Clearance Dimensions

MODEL	A	B	C	D*	E*
	INCHES				
4234 4238 4242	36	36	48	36	36
25 35 50	48				12
65 85 100 120 140 160 180 200	60	48	48	36	36

* 48 inches when area is used as an isle

5.2 If any of the heater room walls are of combustible material, the National Fire Protection Association requires minimum clearances as shown in their Pamphlets No. 31 and 54.

NOTE: The National Fire Protection Association Code requires a fire resistance rating for boiler and heater room walls, floor and ceiling. See the code for this rating.

6. COMBUSTION AND VENTILATION AIR REQUIREMENTS

6.1 Make sure the heater room is properly ventilated. Accumulation of hot air (125° F max) near the heater can cause overload elements to trip, relay malfunctions and other component failures. Lack of adequate combustion air and/or dusty air conditions, which can disrupt the heater blower air flow, can result in smoke and sooted heat transfer surfaces.

6.2 The number and size of air supply vent openings, as required by the National Fire Protection Association (NFPA) numbers 31 and/or 54, depends upon the type of fuel used and the type of enclosure in which the heater is to be located. The total free area of the openings is based upon the total gallons per hour input for oil (Table 4) or the total BTU per hour input for gas (Table 5) for all heaters and appliances located within the enclosure. For example NFPA 31, for oil burning equipment, states that for heater rooms adjacent to outside walls where combustion air is provided by natural ventilation from the outside, there shall be a permanent air supply inlet having a total free area of no less than 10 square inches per gallon per hour of total input rating. For a model 65 heater, fuel oil consumption at high fire is 57 gallons per hour (Table 4). Total free area = 57 x 10 = 570 square inches. For gas burning equipment NFPA 54 states that for a confined heater room with all air supplied from outdoors, there will be two permanent openings, one commencing twelve inches from the top and one commencing within twelve inches from the bottom of the enclosure. Each opening to have a minimum free area of one square inch per 4000 BTU per hour of total input rating. For example, a gas fired model 65 requires 8,250 standard cubic feet per hour at high fire (Table 5). Assuming a 1000 BTU per standard cubic foot heating value; total free area = $\frac{8,250 \times 1,000 \times 2}{4,000}$ square inches or 2,062 square inches per opening.

6.3 If blowers are used to supply sufficient air to the heater room, vent openings may not be required if such devices are approved by the authority having jurisdiction. If the air supply is dependent upon a blower, an interlock switch should be provided to prevent the heater from firing if the blower fails.

6.4 Vent openings must be increased to compensate for the blocking effect of louvers, screens, guards and filters. For example, NFPA states that for an opening having metal louvers a free area of 75% may be assumed. The total free areas obtained in paragraph 6.2 must be increased thus, $\frac{570}{.75} = 760$ sq. in. and

$\frac{2062}{.75} = 2,750$ sq. in. to obtain the area of the wall opening.

6.5 The wall openings must also be increased to compensate for the cubic feet per minute of air being removed from the room by exhaust fans. The increase will be dependent upon the capacity of the fans.

6.6 The Vapor Power heater is so protected that it will not fire should the heater room temperature drop below 0° F and the heater has been shutdown. A method of heating the heater room should be provided to allow the heater to be fired and also to prevent pump cooling water from freezing. (See Figure 15)

NOTE: Consult the manufacturer of your heat transfer fluid for low temperature pumping information and your Vapor Power Sales Engineer for low temperature firing of the heater.

6.7 Table 3 lists the minimum combustion air requirements per heater.

7. STACK INSTALLATION - EXHAUST GASES

7.1 The recommended installation is to have the stack supported independent of the heater and run straight up to the outside with drainage provided at the bottom. If this is impossible, a second choice of stack installation would be for the heater stack to enter the main stack at no less than 45° as illustrated in Figure 2. An alternate to the above installation is illustrated in Figure 3 and discussed in paragraph 7.6.

7.2 A vertical stack should extend through the roof and have provisions for drainage. The heater should not be used to support the weight of the stack. (See Figure 2)

7.3 All stacks should be at least five feet above any adjacent wind obstructions and no less than ten feet above the roof.

7.4 All stacks shall be provided with a drawband connection to the heater for ease of heater repair.

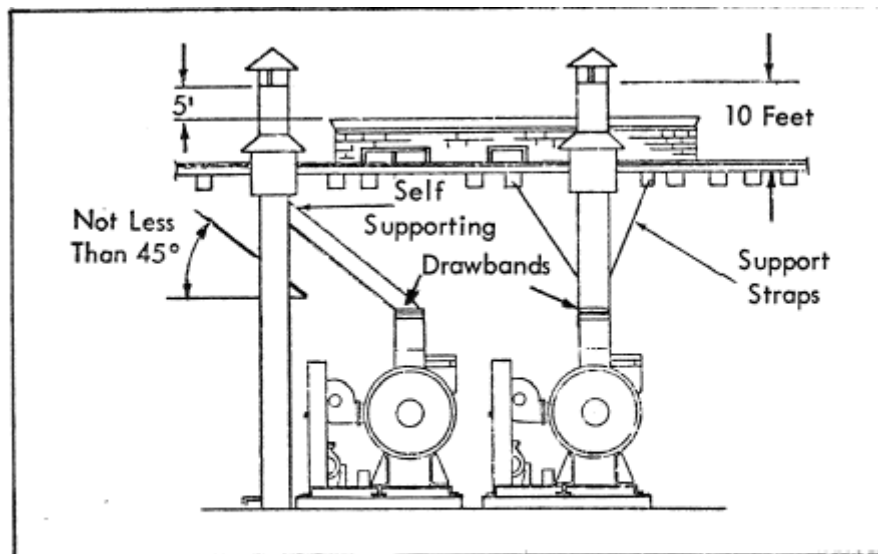

Figure 2, Recommended Stack Installation

MINIMUM AIR REQUIREMENTS

MODEL SIZE	COMBUSTION AIR REQUIRED (SCFM)
4234	137
4238	230
4242	485
25	665
35	889
50	1346
65	1778
85	2263
100	2687
120	3233
140	3772
160	4510
180	4870
200	5412

Table 3

NOTE: Insulation on the stack should be installed so that it will not be destroyed when taken apart at the drawband.

7.5 The stack should be designed with the required bracing, or hangers to be self- supporting. (See Figure 2) A section of the stack should be removable to permit inspection for corrosion and soot buildup. An inspection door or panel may be inserted if removal of a section of the stack will be difficult, the minimum recommended material thickness for stacks and breeching is 14 gauge. Stack connection sizes are shown in Table 3A.

STACK REQUIREMENTS

MODEL SIZE	STACK DIAMETER (In. O. D.)	STACK AREA (Sq. In.)
4234	8½	57
4238	10	79
4242	10	79
25	12	111
35	14	151
50	16	198
65	18	251
85	20	310
100	24	448
120	24	448
140	28	615
160	28	615
180	30	707
200	32	798

Table 3A

7.6 Horizontal runs should be pitched up 1/4 inch per foot, and the diameter of the pipe should be increased 5% over the preceding pipe diameter at each 10 foot interval in the horizontal run. A 10% increase in pipe

diameter over the preceding diameter must be made at each elbow (see Figure 3). Horizontal runs should be provided with a clean out door. Round stacks and breeching are preferred.

7.7 The Vapor Power heater is fired with a forced draft supplied by its own blower, therefore, the stack installation need add no draft through the heater. However, the stack should be of sufficient size to provide free discharge of exhaust gases without back pressure. Stack draft should not exceed -0.3 inches of water column when the heater is operating at high fire and the stack temperature has reached a steady value.

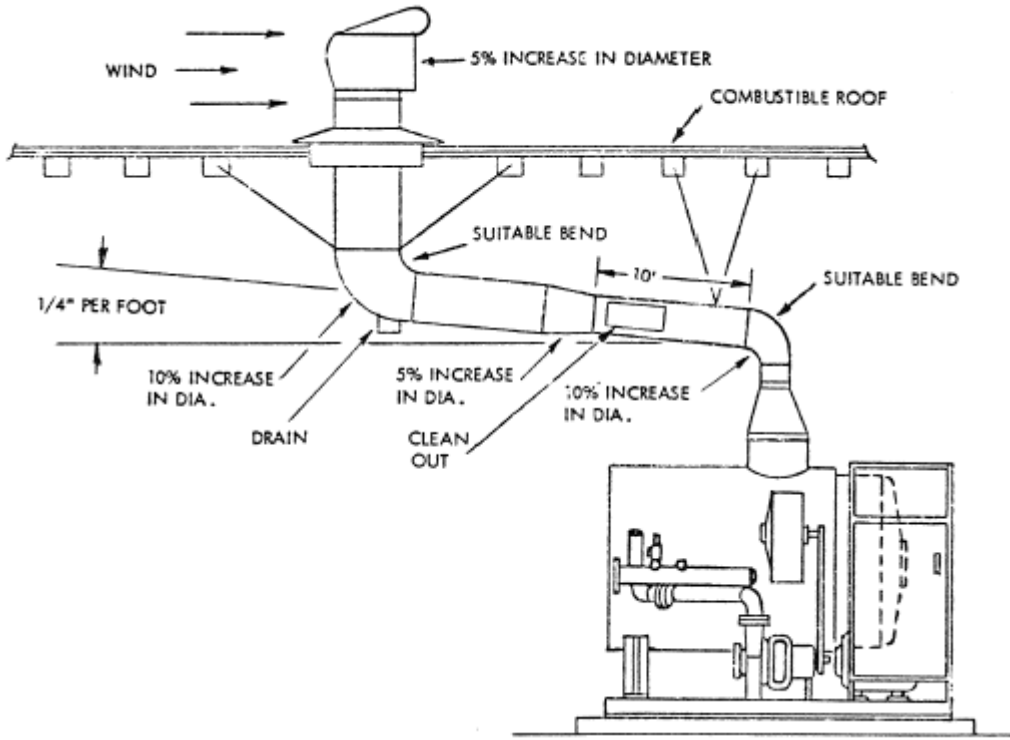
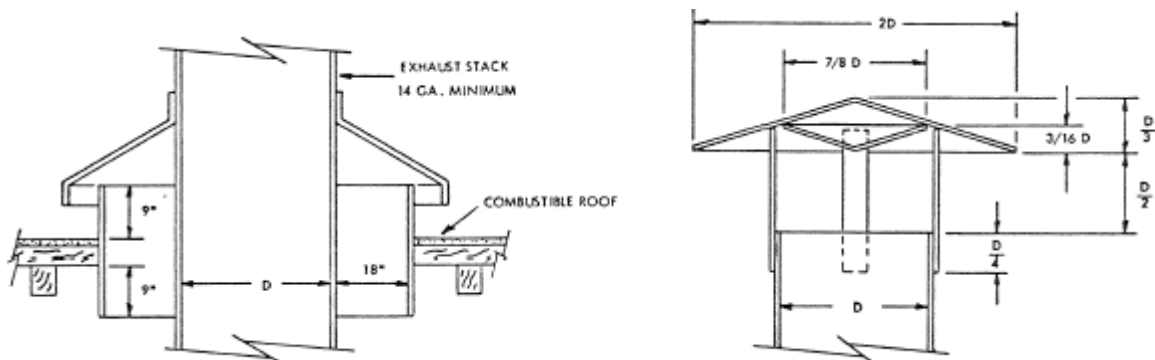

Figure 3, Stack Installation With Horizontal Run

7.8 The Building Code Standards of the National Fire Protection Association require that where a metal stack passes through a combustible roof, such roof shall be guarded by a metal sleeve or thimble extending not less than nine inches above and below the roof, and providing not less than eighteen inches clearance on all sides of the stack. (See Figure 4)



7.9 If more than one heater is to be connected to a single main stack, the cross sectional area of the main stack must be equal to, or greater than, the sum of the areas of all connecting stacks.

7.10 In areas where unusually high draft conditions prevail a method of reducing the draft is necessary. An orifice, barometric damper or adjustable damper must then be installed in the exhaust stack to reduce the draft to the limits indicated in paragraph 7.7.

7.11 The ideal draft regulator is an electric or hydraulic automatic positioning type. These regulators maintain a constant draft on the heater under all variances of heater firing rates and atmospheric conditions.

7.12 When it is necessary to increase draft from what is available, the height of the stack must be increased or an induced draft fan installed in the exhaust system.

7.13 The stack should be protected against down drafts, back drafts, and rain with a simple flat or cone-shaped cap, (See Figure 5) Make sure the area between the cap and stack is at least equal to the area of the stack. Protect all steel work from corrosion.

7.14 In cold climate regions and/or regions of high humidity, a shutoff damper must be installed in each stack, When closed, the shutoff damper will prevent the heater coils from sweating, heat transfer liquid from becoming too viscous, and water in pump cooling jackets from freezing by outside air that is drawn into the heater when it is shut down. This is applicable to a heater installation with multiple stacks or an installation with a single stack in a building with depressed atmospheric pressure. (See Figure 15)

8. FUEL SUPPLY

8.1 Oil and Combination Fired Heaters

8.1.1 Select a supply tank of adequate capacity using Table 4 and paragraph 8.1.3.

8.1.2 See OSHA standards for vent requirements versus size of tank required. On marine applications, vent and tank requirements must conform to USCG regulations.

8.1.3 The following method may be used to determine the minimum size of the fuel tank. If you have a Model 35 heater it will burn 29 gallons of No. 2 fuel oil per hour (at high fire). For an eight hour day and seven days a week, you will need $8 \times 29 \times 7 = 1624$ gallons of fuel per week. We recommend a tank that will hold a minimum of two weeks supply.

8.1.4 Install the fuel tank outside if possible (underground is preferred) and as near to the heater as codes permit. Many local codes designate particular locations. Keep suction lines as short and as free of fittings as possible. (See Figure 6)

NOTE: Before selecting the size of your oil storage tank check with your fuel oil supplier to find the most economical quantities in which to order, as it could be a major factor in tank size.

HEATER FUEL REQUIREMENTS AND LINE SIZES

MODEL	FUEL CONSUMED AT FULL OUTPUT RATE (No. 2 Fuel Oil) (Gallons/Hour)	FUEL SUPPLY LINE NPT (Inch)	FUEL RETURN LINE NPT (Inch)
4234	3.6	3/8	3/8
4238	7.2	3/4	1/2
4242	13.5		
25	22		
35	29		
50	44		
65	57		
85	75		
100	87		
120	102		
140	122		
167	140		
180	158		
200	175		

Table 4

8.1.5 If you use a floor mounted or an overhead tank, install a shutoff valve in the suction line ahead of the strainer to facilitate removal for cleaning. (See Figure 7)

8.1.6 The fuel pump delivers fuel at a constant rate of 174 gallons per hour despite the amount burned, so it is important to size fuel suction and return lines properly. Size the return line so there is no back pressure; refer to Table 4. These line sizes cover only a single heater installation with lines not longer than 100 feet in length. For multiple heater installation and/or lines exceeding 100 feet in length, a corresponding increase in

pipe size must be made to compensate for the increased flow rate or pipe restriction due to length.

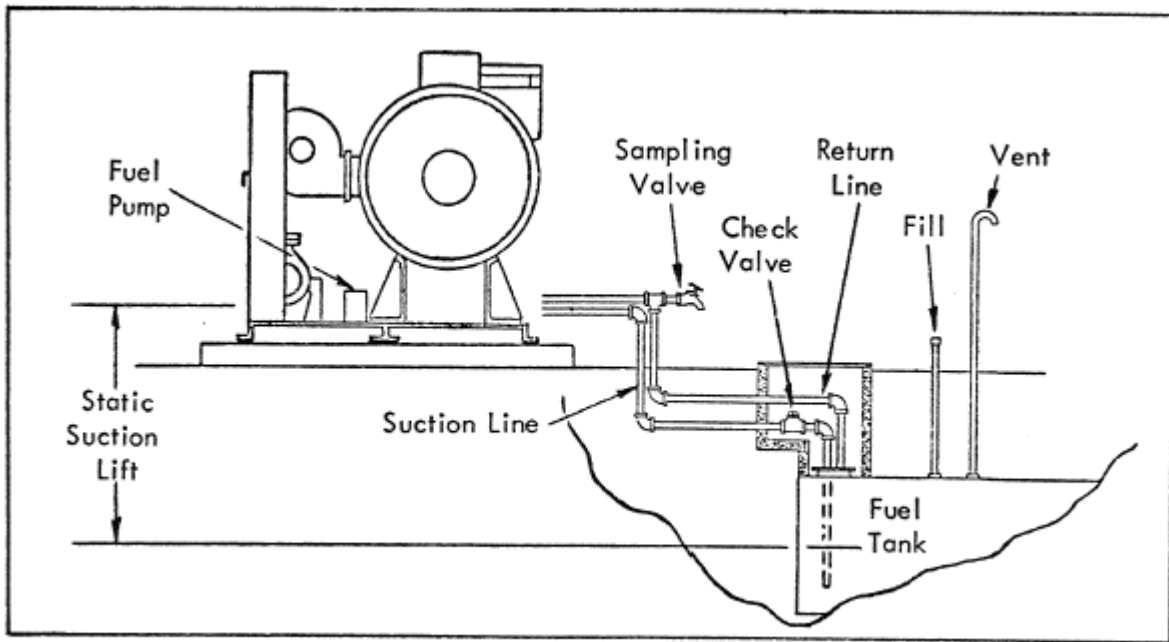

Figure 6, Underground Fuel Tank Installation

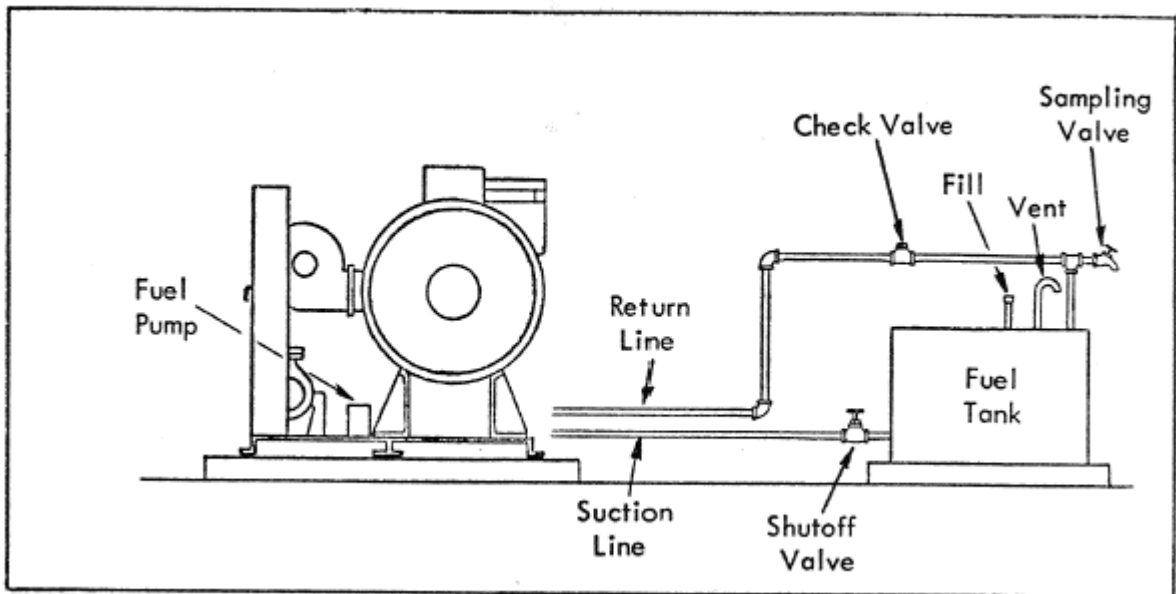

Figure 7, Fuel Tank Installation

8.1.7 The return line should always be piped back to the supply tank and never to the suction side of the fuel pump. Return line back pressure should not exceed 10 psig at the heater, which includes the static head pressure if the fuel tank is elevated.

8.1.8 If the dynamic suction lift (static suction lift + friction loss of pipe and fittings) exceeds 15 feet of water at the customer connection to the heater, it will be necessary to install a fuel transfer pump. The pump must be located between the main tank and customer connection to the heater and have a capacity of 174 to 180 gallons per hour per heater.

CAUTION: Do not put more than 25 psig to the inlet of the heater fuel pump. Pressure over 25 psig will damage the fuel pump seal. Do not operate fuel pump without oil or it will be damaged.

8.1.9 Use only gate valves in the fuel piping lines to minimize resistance in the fuel piping system.

8.1.10 If your fuel tank requires heating because of freezing temperatures; install a steam heating coil in the tank.

CAUTION: Do not install any steam heating coil operating at a pressure of more than 15 psig in a fuel oil tank.

8.1.11 Place a sampling tee and valve in the fuel return line and install a vent pipe in the fuel supply tank. See Figures 6 and 7. Also the typical heater installation drawing, Figure 15.

8.1.12 Some customers prefer to remotely install the heater fuel pump (and bypass relief valve) as a method of overcoming the suction lift problem. This practice is acceptable provided a check valve is installed in the pump discharge line to the heater as close to the pump as possible.

8.1.13 Heater installations under the jurisdiction of FM, CSD-1, NFPA, CSA, etc. may require additional equipment. As code requirements are subject to change, please consult with your local insurance inspector for equipment requirements.

8.2 Gas Fired Heaters

8.2.1 The size of your gas line is determined by the gas pressure at the meter, the resistance of the pipe and fittings to gas flow and the volume of gas flow to the heater in cubic feet per hour. Vapor Power Liquid Phase Heaters require at least 1 psig of regulated gas pressure at high fire at the heater customer connection. Your local gas company can help you to determine the proper size of piping you will require.

8.2.2 When installing the gas regulators and piping be sure to observe all regulations of the National Fire Protection Association and all local regulations that may apply.

8.2.3 Gas flow requirements for Vapor Power heaters, main burner customer connection sizes, and gas pressures required at the customer connection are listed in Table 5.

NOTES:

1. Gas flow required will change with the BTU content of the gas.
2. Consult your gas pressure regulator manufacturer (Maxitrol, Fisher or equivalent) for size and type required for your specific application. Regulators are supplied by Vapor on units requiring Canadian Gas Association (CGA) approval .
3. Regulators to be adjustable above and below 1 psig or other indicated regulated pressure.

GAS CONSUMED & GAS LINE CONNECTION REQUIREMENTS

MODEL SIZE	HIGH FIRE GAS FLOW REQUIRED (SCFH)*	CUSTOMER MAIN GAS CONN. (NPT)(INCH)	CUSTOMER CONN. MAIN GAS PR. AT HIGH FIRE (PSIG)
4234	513	1 ¼	1.0
4238	1,025	2	
4242	1,923	2	
25	3,125	2	
35	4,125	2	
50	6,250	2 ½	
65	8,250	3	2.0
85	10,750	3	
100	12,500	3	
120	15,000	3	
140	17,500	3	
167	20,000	3	
180	22,500	3	
200	25,000	3	

Table 5

* Based on heat value of 1000 BTU/standard cubic foot.

8.2.4 If your main line gas pressure is less than 1 psi, consult Vapor Power as it may be possible that your gas pressure will be adequate if certain changes are made. However, it may be necessary to install a gas booster. If local codes permit, we recommend a Roots-Connorsville Booster with a built in bypass valve installed as close to the heater as possible. When ordering a booster, specify the following:

- a. Inlet pressure (main gas line pressure).
- b. Outlet pressure sufficiently in excess of the required pressure at the heater to maintain that required pressure at the heater.
- c. Gas flow rate (see Table 5) also specify type of gas and BTU content.

NOTE: Due to heat of compression it is best to cycle booster off when the heater cycles off.

8.2.5 When ordering a gas regulator, specify data from Table 5 for your model size, your main gas line pressure and standard trim for natural gas (0.60 specific gravity),

NOTE: Two regulators in series may be required to obtain accurate regulation and to meet local codes.

8.2.6 The selected gas regulator(s) may be installed anywhere between the meter and the heater, but must be located upstream of gas line safety equipment. Wherever the regulator is located, it must be capable of supplying the required pressure at the heater connection. Figures 9, 10, 11, and 15 illustrate a gas pressure regulator installation.

NOTE: If a sensor line is required, it shall be connected downstream from the regulator at least five (5) pipe diameters - The connection must also be at least five (5) pipe diameters downstream or two (2) diameters upstream from any valve, elbow or other restriction.

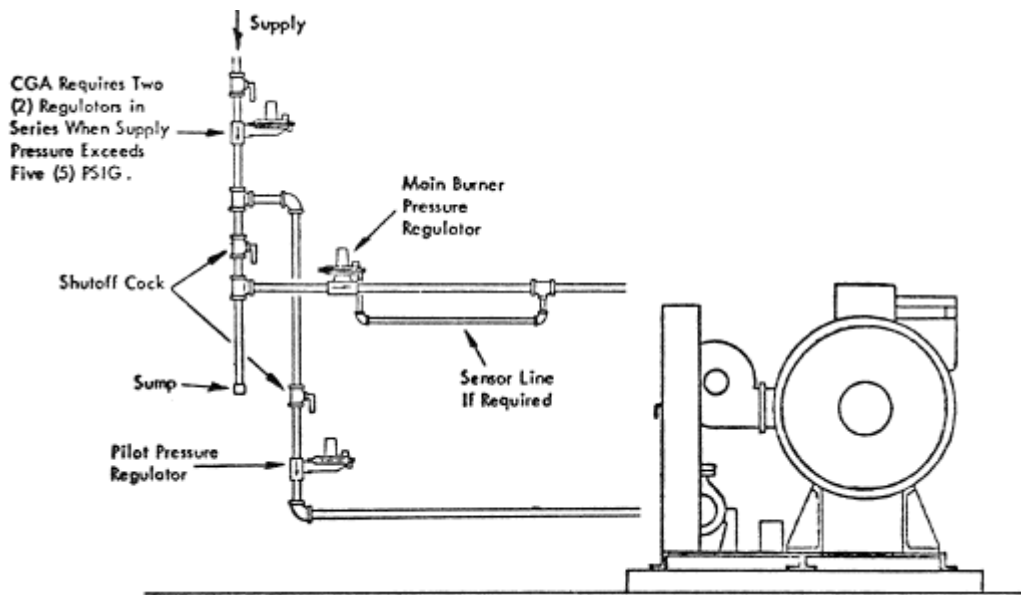

Figure 9, Gas Regulator Installation

8.2.7 Heater installations under the jurisdiction of FM, CSD-1, NFPA, CGA, etc. may require additional equipment. As code requirements are subject to change, please consult with your local insurance inspector for equipment requirements.

NOTES: 1. A separate pilot burner regulator and a separate main burner regulator must be installed for each boiler when multiple installations are made.

CAUTION: In all instances concerning gas pressure regulators, boosters, reducers, piping, etc., consult with your local gas supply company. Follow their recommendations and preferences; also

follow the codes for gas fired equipment as set down by the AGA, CGA, and the National Fire Protection Association.

8.2.8 Install a manual shutoff cock in the line between the meter and the gas pressure regulator.

8.2.9 Install a sump trap to collect residual moisture and oil in the gas line. The trap should be located between the main regulator and manual shut off cock.

NOTE: Combination fired models must meet the codes for both gas and oil fired types. All instructions given above for oil and gas fired heaters apply to the combination fired models.

9. PILOT BURNER GAS REQUIREMENTS

9.1 All standard oil, gas and combination oil/gas fired heaters use gas pilots. Oil fired units used in marine installations are direct spark ignited and, therefore, not fitted with gas pilot burner. Liquid petroleum gas (LPG) may also be used for pilots.

9.2 Natural gas pilots may be either interrupted or constant, requiring 4 inches W.C. gas pressure. All LPG pilots require 11 inches W.C. pressure. These pressures are required at the pressure tap located at the rear of the control cabinet, adjacent to the pilot solenoid.

9.3 All units fitted with gas pilot burners have a 3/8 inch NPT pilot gas connection.

9.4 The pilot gas regulator may be installed anywhere between the meter and the main gas regulator and must be capable of supplying the required pressure at the heater connection. Figures 9 and 15 illustrate a gas pressure regulator installation.

10. COMPRESSED AIR REQUIREMENTS (OIL FIRED HEATERS)

10.1 If your heater is oil fired, or combination oil/gas fired type, it will require compressed air at the burner nozzle for fuel atomization. Table 6 indicates the pressure and cubic feet per minute of free air required for your particular model.

FUEL ATOMIZING AIR REQUIREMENTS

MODEL SIZE	AIR FLOW REQUIRED (SCFM)	AIR PRESSURE REQUIRED AT HIGH FIRE (PSIG)	HEATER CONNECTION (NPT)(INCH)
------------	--------------------------	---	-------------------------------

4234	3.0	30	3/8
4238	5.0	40	
4242	5.9	40	
25	9.0	20	
35	9.0	20	
50	9.0	20	
65	10.0	20	
85	11.0	20	
100	11.0	20	
120	12.0	20	
140	20.0	30	
160	23.0	30	
180	23.0	30	
200	23.0	30	

Table 6

10.2 It is recommended that a suitable filter be placed in the compressed air line to the heater to filter out oil, water and dirt. At least once a day, more often if required, the compressor tank and filter must be bled to remove accumulated water, oil and dirt.

11. POWER SUPPLY REQUIREMENTS

NOTE: The National Fire Protection Association Code requires a fire resistance rating for boiler and heater room walls, floor and ceiling. See the code for this rating.

11.1 It is important that you use the proper size wire to bring the electrical power to the heater. There should be no more than 3% voltage drop in the feeder line.

11.2 There must be a remote fused disconnect switch installed for the heater main power supply and no other load should be connected to this switch, except for the pump cooling water solenoid valve, if used.

11.3 Use moisture resistant insulated wire, with a 100 C rating for high temperature service.

11.4 All electrical connections, between the heater and the building wiring shall conform to the National Electrical Code, USAS STD. C1-1968 and NFPA No. 70- 1968 when no other local electrical codes apply.

KVA DRAW FOR VARIOUS MOTORS & VOLTAGES

MOTOR H. P.	230 V., 460 V., 575 V.	
	RUNNING DRAW (KVA)	LOCKED ROTOR DRAW (KVA)

5	6.8	36.6
7 1/2	9.6	53.3
10	11.9	65.2
15	17.4	96.3
20	22.2	124.9
25	27.8	153.5
30	32.6	187.0
40	42.0	249.0
50	52.5	299.0
60	62.0	358.9
75	77.0	442.5
100	99.4	588.0

Table 7

NOTE: All motors shown are 3 phase, Induction type Squirrel-cage. All values shown include 0.750 KVA for control panel draw.

$$Amps = \frac{KVA \times 1000}{1.73 \times Volts}$$

Ref. for AMP values; NEC 1968, NFPA 370-1968,
USAS: C1-1968, Pp, 70-243 and 70-244

11.5 The proper fusing for the heater remote main power disconnect switch is also important. Table 7 indicates the KVA draw for various size motors.

11.6 Check the heater test sheet for rated voltage. Low voltage will result in reduced blower and pump speed. Motors will operate satisfactorily if the voltages shown in Table 7 vary no more than + 1(P/o at rated frequency of 60 hertz. Motors will also operate satisfactorily if the combination of + 10% variation in voltage and frequency occurs, providing the frequency variation does not exceed 5%.

11.7 When line voltages are not exactly the same on all phases, unbalanced currents will flow in the stator windings. A small voltage unbalance can increase the temperature rise and current, at operating speed, by 6 to 10 times the voltage unbalance. A 3 1/2% voltage unbalance can cause a 25% increase in temperature rise. For example, if line voltages are measured at 230 VAC, 225 VAC, and 220 VAC, the average line voltage is 225 VAC. The maximum deviation from average is 5 volts. The percent unbalance equals $225 \div 5 \times 100 = 2.22\%$. The increase in temperature rise is 2 times the percent unbalance squared or $2(2.22) = 9.9\%$. To avoid motor damage, notify the power company of voltage unbalance so the situation may be corrected.

12. CIRCULATING PUMP

12.1 Pump Installed on Heater

12.1.1 If your heater circulating pump is equipped with a flexible coupling, it must be properly installed and aligned per instructions given in your heater Instruction Manual before attempting to operate the heater. Final alignment must be made at or near the operating temperature of the pump.

CAUTION: Damage to the pump and motor will result if run
 with the coupling not properly aligned.

12.1.2 If your heater circulating pump is belt driven, the pulley alignment should be checked. The belts must be tightened to the proper tension per instructions given in your heater instruction manual.

12.2 Circulating Pump not Installed on Heater

12.2.1 Occasionally a circulating pump other than that supplied by Vapor Power, may be purchased separately and mounted off the heater. In this case, Vapor Power Sales must be consulted for the pump head and capacity, which, with the addition of the required system head, will provide information for purchasing the pump.

12.2.2 This pump will probably be equipped with a flexible coupling and therefore, instructions on alignment discussed in paragraph 12.1.1 should be followed.

12.2.3 Do not install piping between the pump discharge and heater that will permit heat transfer fluid to bypass heater.

12.2.4 Specify auxiliary contacts on pump magnetic starter, to be interlocked with heater firing circuit as shown on your wiring drawing. Use 120 VAC supply from heater to energize magnetic starter to provide automatic cooling of heater on shutdown, and for safety in case of stack switch actuation.

12.3 Pump Cooling Water – Does Not Apply to Pumps Provided with Air Cooled Mechanical Seals

12.3.1 The inlet water line for cooling the circulating pump mechanical seal must be equipped with two (2) valves. One to be a manually operated valve for metering flow and the second to be a solenoid valve wired to the main switch. The cooling water discharge piping must not contain valves and should be piped to an open drain.

12.3.2 The pump should have a flow of 1 to 2 gallons per minute of water circulating through the stuffing box and bearing housing jackets at a pressure not to exceed 125 psig. The flow and temperature of the cooling water can be determined and controlled by the manual valve in the inlet line. The cooling water outlet temperature must not exceed 140° F. On marine installations, or where heat transfer fluid temperatures will not exceed 550° F, heater pumps may be optionally equipped with mechanical seals which do not require cooling water.

CAUTION: Never operate the heater circulating pump with a fluid temperature

over 350° F without cooling water circulating through the stuffing box and bearing housing jackets unless the pump is designed to operate without cooling water. Use soft water, if possible.

2.3.3 If the circulating pump is to be subjected to freezing temperatures or drafts when shutdown, the stuffing box and bearing housing jackets (two connections) must be drained of all water to prevent damage from freeze-up.

13. SYSTEM PIPING (GENERAL)

13.1 Pressure Drop

13.1.1 The most important factor in the piping layout for a fluid system is the sizing of the main heating loop, number and size of lines to each user or, in the case of marine applications, the number and size of loops in each hold. Piping should be designed to handle the required flow rate of minimized pressure drop. In some cases, balancing valves must be used to obtain desired branch flow. Also it may be necessary to install an orifice to maintain a specified flow and prevent overloading the pump motor.

13.2 Expansion

13.2.1 Since system piping will undergo considerable and rapid temperature changes, it is essential that adequate expansion loops and joints be used to minimize pipe stresses due to expansion and contraction.

13.2.2 System return piping to the circulating pump must be anchored to the floor to prevent forces, created by thermal expansion and contraction of the system piping, from acting against the circulating pump. The piping must be anchored as close as possible to the pump inlet. A suitable flexible connector must be installed between the system return piping and the anchored piping at the pump inlet. The weight of system piping must be supported by pipe hangers and/or roller supports. However, to prevent lateral or angular movement of pipe, pipe alignment guides should be used which allow only axial movement. For example, the system return piping with the flexible connector should have an alignment guide installed 4 pipe diameters upstream of the connector. A second guide should be located no more than 14 pipe diameters upstream of the first guide. Piping to and from the heater must be independently supported .

13.3 System Materials

13.3.1 The manufacturer of your heat transfer fluid should be consulted to ascertain if your system materials are compatible with the fluid used. For example, some fluids are not compatible with copper alloys. Also copper, aluminum, bronze and brass alloys lose their metallurgical strength at elevated temperatures.

13.4 Threaded Connections

13.4.1 Vapor Power recommends that threaded connections be avoided in larger pipe sizes. If threaded connections must be used, a clean new die should be used in cutting the threads to assure a proper fit. Careful attention to threading procedure should be used instead of pipe thread compound, to obtain a good tight threaded connection. When threaded connections are made, use of a high temperature thread sealant tape such as GRAFOIL or equivalent, or an adhesive type pipe thread compound such as SAUERISEN # 31 or equivalent, is recommended.

13.5 Flanged Connections

13.5.1 It is characteristic of most heat transfer fluids at high temperature, to have a tendency to leak at connections, unless these connections are very tight. Flanged connections are recommended but should be used sparingly to minimize potential leaks. In larger size pipes, welded connections should be used wherever practical. Careful layout and use of curved sections of pipe can minimize the welded or flanged connections required; when flanged connections are made, American National Standards Institute (ANSI) raised face flanges are recommended. Flanges of the 150 pound class, with proper gasketing, are usually adequate for most systems. Spiral wound (SPIRATALIC or FLEXITALLIC) graphite and stainless steel gaskets are good.

13.5.2 It is recommended that high temperature bolts, ASME, SA 193 Grade B6 or better which do not yield, be used with ASME, SA 194 Grade 2 or 2H nuts, for securing all flanged joints.

13.6 Valving

13.6.1 Flanged valves of the 150 pound class are usually satisfactory for most systems. Cast steel gate valves with deep stuffing boxes are recommended.

13.6.2 Your Vapor Power Liquid Phase Heater is supplied with a safety relief valve set to relieve at a specific design pressure. This valve must relieve to the expansion tank as illustrated in Figures 13 and 14. This is a heater safety device only and is not to be used to protect your system or its components. System relief valves should be installed where required.

13.6.3 All system piping must be provided with vent valves as well as drain valves. (See Figure 12) It is customary to vent all high points in a system for removal of air from the system during filling. However, there may also be low points in the system where air can become trapped and should be vented. Long horizontal runs should also be vented at each 50 foot interval. System drains must be located at all low points and at other points where fluid can be trapped, should it ever become necessary to completely drain the system.

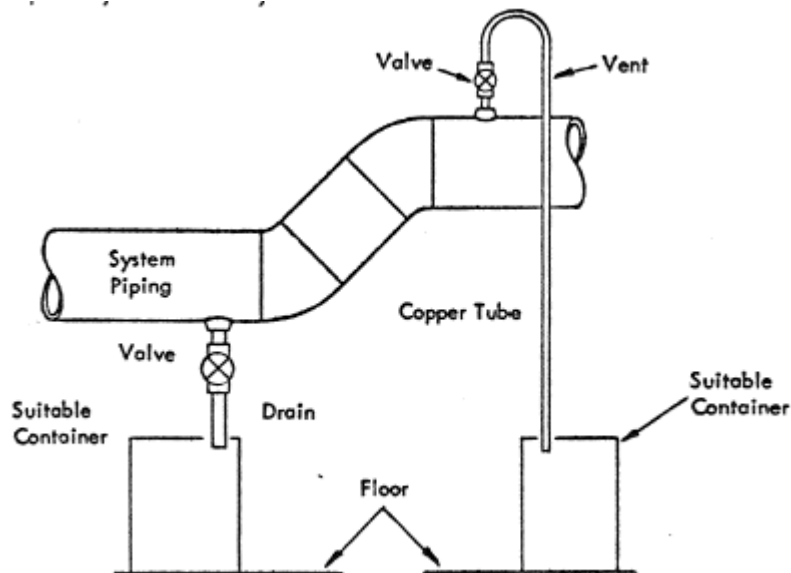

Figure 12, Typical System Vent and Drain

13.7 Strainer and Filter

13.7.1 Install a full pipe size, flanged strainer in the system return line as close to the heater as possible, so that it can be serviced conveniently. As illustrated in Figures 13 and 14, the expansion tank downcomer line must be connected to the return line between the strainer and the pump inlet. The system should be heated to operating temperature and cooled, for a minimum of two (2) cycles. The resultant expansion and contraction will loosen pipe mill scale.

13.7.2 The strainer screen should be of perforated sheet metal with approximately 3/32 inch to 1/8 inch diameter holes. The ratio of the open area of the screen to the inside area of the pipe (OPEN AREA SCREEN/PIPE AREA) must be a minimum of 3.75.

13.7.3 As illustrated in Figures 13 and 14, a flanged gate valve should be installed on each side of the strainer. A drain line with valve should be installed between the two gate valves for draining that section of pipe. A small drain line and valve may also be installed in the strainer. This will facilitate removal and cleaning of the strainer screen.

13.7.4 It is recommended that a high-temperature filter be installed on a bypass line off the main heating loop as illustrated in Figure 15. The filter should be isolated with flanged gate valves and drain line, for periodic cleaning. A metering valve should be installed downstream of the filter to control flow through the filter.

Pressure gauges should be installed each side of the filter to be used as a guide for changing filter elements. The filter should be at ground level for ease of maintenance. High temperature, ten (10) micron particle retention filter elements should be used.

NOTE: Vapor Power recommends that all valves and accessories be thoroughly cleaned before being installed to insure a clean system before filling with heat transfer fluid. (See Paragraph 16)

13.8 Expansion Tank Installation

13.8.1 Proper design of the expansion tank for the fluid system is quite simple, but is also very important for proper system operation. (See Figures 13 and 14)

13.8.2 Heat transfer fluids expand in volume about 2 to 6 percent per 100° F change, depending upon operating temperature and fluid used. The expansion tank must be sized so that it is about 3/4 full when the system is at maximum operating temperature and 1/4 full when at ambient temperature. Therefore, one-half of the tank capacity must accommodate the expansion of the entire system. This would include the fluid content of the heater (See Table 8) system piping, and all heat users or loops. Total tank capacity is then two times the capacity required for expansion. For actual expansion data, consult your fluid supplier. As an example, assume a system including heater, piping, and users has been calculated to hold 1000 gallons. The operating temperature is 500 F. The fluid manufacturer lists the thermal expansion multiplier as 1.22 for 500° F. The total system volume at 500 F. will be $1000 \times 1.22 = 1220$ gallons. The expansion due to heating is $1220 - 1000 = 220$ gallons. Using the guidelines above for sizing the expansion tank, where the expansion should fill approximately one-half of the tank, the total tank capacity is $220 \times 2 = 440$ gallons. A standard Vapor Power expansion tank for this application would be 500 gallons.

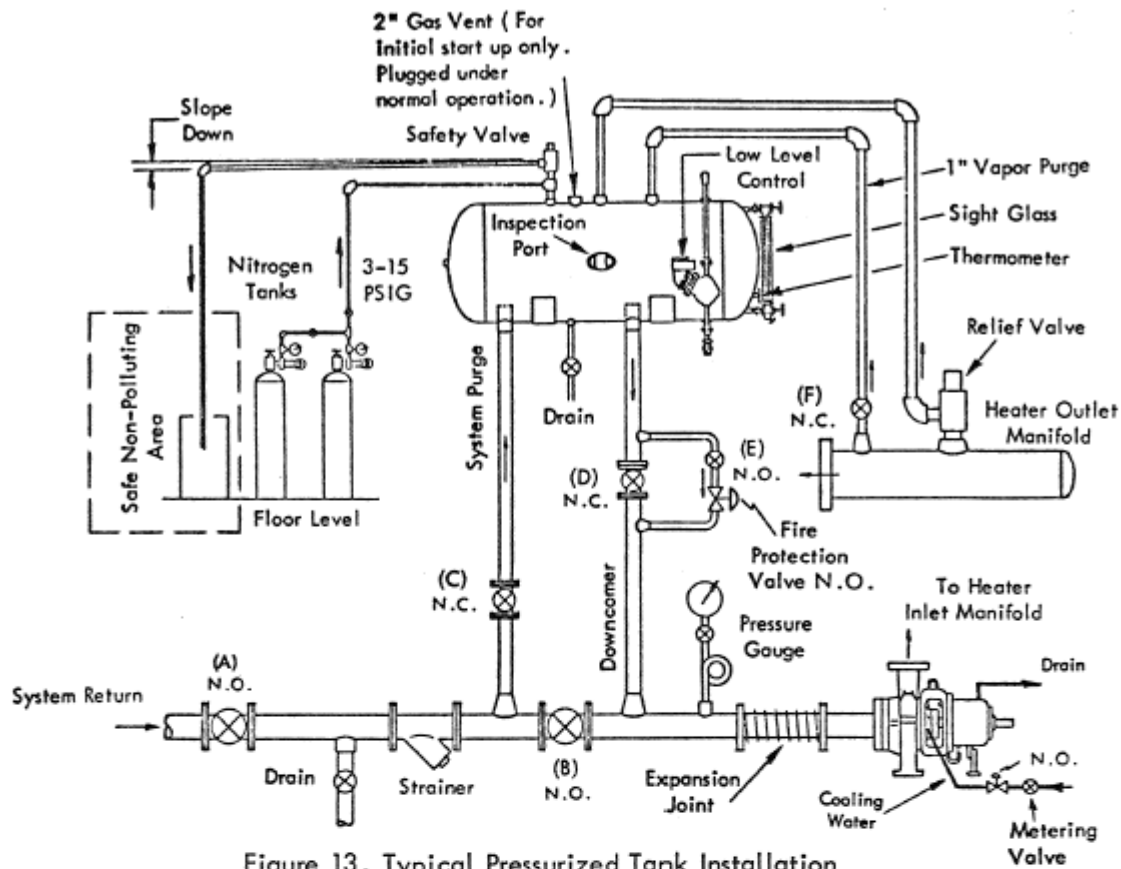

Figure 13, Typical Pressurized Tank Installation

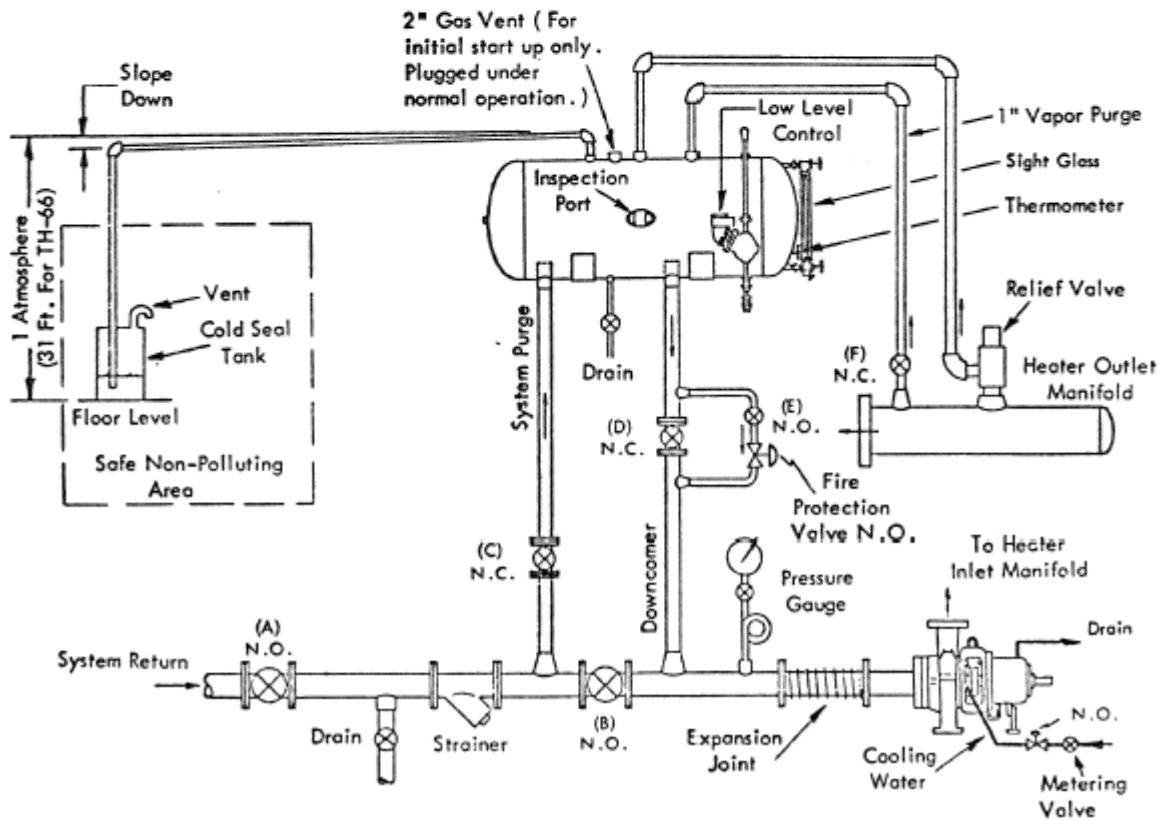

Figure 14, Typical Vented (Cold Seal) Tank Installation

13.8.3 The expansion tank should be fitted with a sight glass indicating, as nearly as possible, the full depth of the tank, a float operated low-level switch to shut the burner off in case of accidental fluid loss and a thermometer to indicate the tank fluid temperature. A 50 to 500° F range is required. However for marine applications, the thermometer should be capable of indicating 0° F. Install a bottom drain valve in the expansion tank for draining accumulated sludge and/or water. Heat transfer fluids such as Mobil 600, Therminol 55, and Humble 500 (Caloria HT-43) have specific gravities less than water so water may be drained from the tank. This is not the case for such fluids as Therminol 66, Dowtherm A, and Dowtherm E.

FLUID CAPACITIES OF VAPOR POWER HEATERS

Model Size	Approximate Fluid Volume U.S. Gallon
25	24
35	36
50	47
65	86
85	123
100	151
120	180
140	209
160	235
180	261
200	425

Table 8

13.8.4 Besides accommodating the expansion of system fluid, the expansion tank also serves as an oil seal to prevent air from coming in contact with the system fluid and as the major venting point of the system. Where allowance has not been made for oxidation protection, such as nitrogen blanket or cold seal method, the expansion tank fluid temperature should be kept as low as possible to minimize problems resulting from fluid oxidation. When using petroleum based heat transfer fluids, the expansion tank temperature should not exceed 130° F.

13.8.5 The expansion tank must be installed close (2 to 3 feet) to the suction side of the circulating pump and be located above the highest point in the system. Connect the tank to the system return piping with two (2) lines, one pipe size smaller than the system return piping but not to exceed 3". The downcomer, as illustrated in Figures 13 and 14, and the 3/4" bypass line, provides the necessary head to the pump inlet during normal operation. Thermal recirculation will not occur during normal operation, since the main valve (D) is closed directing fluid through the bypass line. The system purge line (see Figures 13 and 14), as the name implies, is used to vent vapors from the system. This line is required for initial start-up only or in the event the system must be drained for repair.

13.8.6 To provide for venting of vapors from the heater on a new installation, a 1" purge line must be installed from the heater outlet manifold to the top of the expansion tank. Again, this line is required for initial start-up only.

13.8.7 The expansion tank must be vented to a safe non-polluting area, away from working areas, to avoid prolonged or repeated contact with the vapors.

13.8.8 Care must be taken to prevent entry of atmospheric moisture into the expansion tank -- and thus into the system – as the fluid expands and contracts due to fluid temperature changes. The recommended method would be to pressurize the expansion tank with 3 to 5 psig of nitrogen (see Figure 13). This will blanket the fluid with an inert gas and thus prevent condensation and oxidation. However, prior to sealing and pressurizing, the system must be purged of all moisture and low boiler vapors. The Vapor Power Service Representative will provide instructions on system drying during the initial start-up of the heater. As noted in Paragraph 13.8.5, the expansion tank should be connected 2 to 3 feet from the pump. If the fluid system design makes this impossible, pressurizing the expansion tank will increase the net positive suction head (NPSH) available to the pump to prevent possible pump cavitation.

CAUTION: If the expansion tank is pressurized, a safety valve must be installed and piped to a suitable container. The safety valve must be capable of relieving the full input capacity of the nitrogen.

13.8.9 An alternate means of preventing moisture from entering the expansion tank would be the cold seal method (see Figure 14). The vent line from the expansion tank is assembled into a separate 55 gallon drum. The line should be positioned approximately 2 inches above the bottom of the drum that is filled approximately one-half full with the same fluid that is utilized in the system. The 55 gallon drum must be provided with a vent line off the top to vent vapors that may be carried over from the system. The top of the drum must be sealed or covered to prevent entry of moisture. As shown in Figure 14, the vent line must be high enough (31 feet) to prevent suction of contaminated oil in drum back into the expansion tank.

13 .9 System Pressure Control Valve (PCV)

13.9.1 The Vapor Power Liquid Phase Heater has been sized to meet your heating requirements at your specified flow rate and system pressure drop. When multiple users are on the system or when more than one control valve controls a single user, a pressure control valve (PCV) must be installed. With all user valves closed, the PCV must be capable of passing 100% of your specified flow rate at the specified system pressure drop. The PCV must have a faster response time than the user control valves.

NOTE: System pressure drop does not include the pressure drop through the heater.

13.9.2 With the use of the system PCV, all user control valves can be straight through or three-way, sized for the required flow in the user, at minimal pressure drop. These valves must have a slower response time than the PCV.

13.9.3 The PCV should be installed at the end of the system loop as illustrated in Figure 15. This would maintain system piping at temperature and minimize thermal stresses due to temperature changes. However, in actual practice, the pressure control valve installed at the end of the system loop is either inaccessible or its location is such that proper maintenance is neglected. If this is the case, it is preferred that the pressure control valve (PCV) be located across the main system loop, near the heater and near the floor such that it will receive the desired maintenance.

14. DELETED

15. TESTING SYSTEM FOR LEAKAGE

CAUTION: DO NOT use water to test for system leakage. It creates the problem of introducing a large amount of water into the system that will be difficult to remove. Water may cause damage to the circulating pump, heat transfer fluid and the heater coils due to boiling and resultant cavitation.

15.1 When a new system has been installed and before it is filled with heat transfer fluid it is important to test for leaks. Probably the most widely used technique is to check for leaks with an inert gas. In this method, the system must be relatively dry and a temporary pipe cap or slip blank installed at the expansion tank vent and at other points where there are no shutoff valves.

15.1.1 Gas is fed into the sealed system followed by air under pressure up to 10 psi. Any leakage areas can be readily detected. Any leakage points can be marked, tightened, and then the system purged.

16. CLEANING THE SYSTEM

16.1 As previously noted, Vapor Power recommends that all pipe lengths, fittings, valves and accessories be thoroughly cleaned before being installed to insure a clean system. The system should be clean before connecting up the heater as it has been thoroughly flushed and drained prior to shipment.

16.2 If the above recommendation has not been followed, the new system will contain dirt, weld slag, and mill scale. These particles must be removed, otherwise they will be carried by the heat transfer fluid to valves, controls, mechanical seals and other mechanical equipment, causing faulty operation or failure of components. As previously recommended, a properly installed strainer will remove some of this material from the fluid.

CAUTION: It is not recommended that the system be cleaned with a vaporizing solvent.

16.3 It is impossible to completely remove all solvent from the system. As heat transfer fluid (mixed with solvent) is recirculated and comes in contact with the hot heater coils, the solvent will vaporize and deposit a carbonateous layer on the inside wall of the coils. This will eventually cause premature coil failure.

16.4 From a practical standpoint, the final cleanup of the system must be made after the heater is connected and the system has been subjected to several heating cycles. (See Paragraph 13.7)

17. SYSTEM FILLING

17.1 Filling By Vacuum (See Figures 13 and 14)

17.1.1 With the system cleaned and the heater connected, a vacuum pump can be connected to the highest point in the system piping. Close all valves to the expansion tank and all valves to nonpressure equipment in the system. Close the pressure gauge valves on the inlet and outlet heater manifolds to avoid possible damage to the heater controls.

17.1.2 Evacuate the entire heat transfer fluid system to approximately 27" Hg, if possible, or until the system has reached the limit of the vacuum pump. Close the valve and shut down the vacuum pump.

17.1.3 With the heat transfer fluid at room temperature (70° F or above), fill the expansion tank. The atmospheric vent on the expansion tank must be open. Introduce the heat transfer fluid slowly into the system by opening the small bypass valve (E) on the downcomer from the expansion tank until the level drops to about 1/4 full. Close the bypass valve, refill the expansion tank and again open the bypass valve. Repeat this process until the fluid no longer flows into the system.

17.2 Filling By Pressure

17.2.1 Open all system valves and vents and expansion tank valves. The atmospheric vent on the expansion tank must also be open.

17.2.2 With all system vent valves manned and heat transfer fluid at room temperature (70° F or above) slowly pump fluid from drums (or storage tank) into the lowest point possible in the system. The system will fill, driving air out of the system through the system vents. The system vents are closed off as fluid reaches each vent point. Continue to fill system until the expansion tank is about 1/2 full. Check each vent again for presence of air.

17.3 Filling By Gravity

17.3.1 Open all system and expansion tank valves. The atmospheric vent on the expansion tank must also be open.

17.3.2 With the heat transfer fluid at room temperature (70 F. or above) slowly pump fluid from the drums (or storage tank) into the expansion tank allowing the system to fill by gravity. As the expansion tank fills, shut off the pump and close the valve between the pump and system.

17.3.3 Open the system vent valves until fluid reaches the vent valves or the expansion tank empties. Refill expansion tank and continue to vent system until fluid stops flowing from the expansion tank.

18. FIRE PROTECTION

18.1 Referring to Figures 13 and 14, a fire control valve is indicated in the bypass line of the downcomer. This control valve works in conjunction with heater fire prevention equipment installed by customers. Should a fire occur in the heater, other than the controlled fire at the main burner, detection equipment would shut the heater down completely, close the fire protection valve to prevent admittance of heat transfer fluid from the expansion tank, and activate extinguishing equipment. System valves should also be closed to isolate the heater and system.

19. NEW UNIT STORAGE

19.1 Should your new Vapor Power Liquid Phase Heater arrive on the job site before the system is ready to accept it, place it in a protected area. It should not be located in an area where workmen will climb on it or can bump into it with heavy equipment.

19.2 As discussed in paragraph 2.3, uncrate and inspect the unit for damage in transit or unloading. Once inspected, the unit should be recovered. Tie the covering down to prevent it from blowing off. This will protect the unit from dirt and possible pilferage.

NOTES:

1. CONNECTION LOCATIONS ON THIS DRAWING ARE SHOWN PICTORIALY. FOR ACTUAL LOCATIONS REFER TO CUSTOMER CONNECTION DRAWING AND HEATER PIPING SCHEMATIC

2. THE MAIN GAS PRESSURE REGULATOR MUST BE LOCATED UP-STEAM OF ANY GAS LINE SAFETY EQUIPMENT. IF A SENSOR LINE IS USED, IT MUST BE LOCATED 5 PIPE DIAMETERS DOWNSTREAM OR 2 PIPE DIAMETERS UPSTREAM OF ANY RESTRICTION.

3. WHEN FM, CSD-1, NFPA, OR CGA REQUIREMENTS ARE SPECIFIED, SEE HEATER PIPING DIAGRAM FOR DETAILS.

4. COMPRESSED AIR IS REQUIRED FOR FUEL ATOMIZATION WHEN UNIT IS OIL FIRED.

5. FUEL OIL STORAGE TANK AND PIPING MUST BE INSTALLED IN COMPLIANCE WITH LOCAL CODES. KEEP CHECK VALVE IN SUCTION LINE.

6. THE PILOT REGULATOR MUST BE LOCATED UPSTREAM OF THE MAIN GAS REGULATOR. GAS PILOT IS STANDARD ON ALL UNITS. OIL FIRED UNITS USED IN MARINE INSTALLATIONS ARE DIRECT SPARK IGNITED. LPG MAY ALSO BE USED FOR PILOTS.

7. INDIVIDUAL VENT LINES ARE RECOMMENDED. WHEN LINES ARE MANIFOLDED, PIPE AREA MUST BE EQUAL TO OR LARGER THAN SUM OF AREAS OF INDIVIDUAL VENT PIPES.

8. HEATER SHOULD NOT SUPPORT THE WEIGHT OF THE STACK OR PIPING.

9. PROVISION SHOULD BE MADE TO DRAIN THE ENTIRE HEAT TRANSFER FLUID SYSTEM.

10. VENT PIPING SHOULD BE PITCHED DOWNWARD SLIGHTLY TO PREVENT CONDENSATION FROM REENTERING THE EXPANSION TANK.

11. AN ADEQUATE STRAINER AND FILLER MUST BE INSTALLED TO PROTECT THE FLUID CIRCULATING PUMP AND CONTROLS.

12. CUSTOMER MUST PROVIDE ADEQUATE EXPANSION JOINTS, LOOPS, ANCHORS, AND GUIDES TO AVOID PIPE STRESSES AND FORCES ACTING ON THE PUMP AND HEATER OUTLET.

13. ADEQUATE SPACE MUST BE ALLOWED AROUND THE EXPANSION TANK TO PERMIT FILLING.