



# **SiFive HiFive Unmatched Getting Started Guide**

## **v1p1**

© SiFive, Inc.

# SiFive HiFive Unmatched Getting Started Guide

## Proprietary Notice

Copyright © 2021, SiFive Inc. All rights reserved.

Information in this document is provided “as is,” with all faults.

SiFive expressly disclaims all warranties, representations, and conditions of any kind, whether express or implied, including, but not limited to, the implied warranties or conditions of merchantability, fitness for a particular purpose and non-infringement.

SiFive does not assume any liability rising out of the application or use of any product or circuit, and specifically disclaims any and all liability, including without limitation indirect, incidental, special, exemplary, or consequential damages.

SiFive reserves the right to make changes without further notice to any products herein.

## Release Information

Version	Date	Changes
v1p1	January 5, 2021	<ul style="list-style-type: none"><li>• Updated Boot Mode Select figure</li><li>• Changed minimum wattage of the power supply unit to be 150W</li></ul>
v1p0	December 14, 2020	<ul style="list-style-type: none"><li>• Initial release</li></ul>

# Contents

<b>1</b>	<b>Introduction</b> .....	<b>2</b>
1.1	HiFive Unmatched Components .....	3
<b>2</b>	<b>Hardware</b> .....	<b>5</b>
2.1	Packaged Components .....	5
2.2	Required Hardware .....	5
2.3	Optional Hardware .....	6
2.4	Qualified Vendor List .....	6
2.5	Problematic Hardware .....	7
<b>3</b>	<b>Board Setup</b> .....	<b>8</b>
3.1	Initial Setup .....	8
3.2	Connecting to the Power Supply.....	10
3.3	Slotting the MicroSD Card .....	11
3.4	Checking the Fan Connection .....	12
3.5	Powering the Board.....	12
3.5.1	Turn ON Power to Board .....	12
3.5.2	Turn OFF Power to Board .....	12
3.6	Connecting IOs to the Board .....	12
<b>4</b>	<b>Boot and Run</b> .....	<b>13</b>
4.1	Connecting with USB Console .....	13
4.1.1	Installing USB-UART Drivers on macOS.....	13
4.1.2	Setting up the Terminal on Windows .....	14
<b>5</b>	<b>Support for HiFive Unmatched</b> .....	<b>17</b>

# 1

## Introduction

The HiFive Unmatched is a Linux development platform based on SiFive's Freedom U740 SoC. The platform features 64-bit DDR4, high-speed interconnects via PCIe Gen 3 x8 operating at 7.8 GB/s, Gigabit Ethernet and SuperSpeed+ USB (5Gbps).

## 1.1 HiFive Unmatched Components

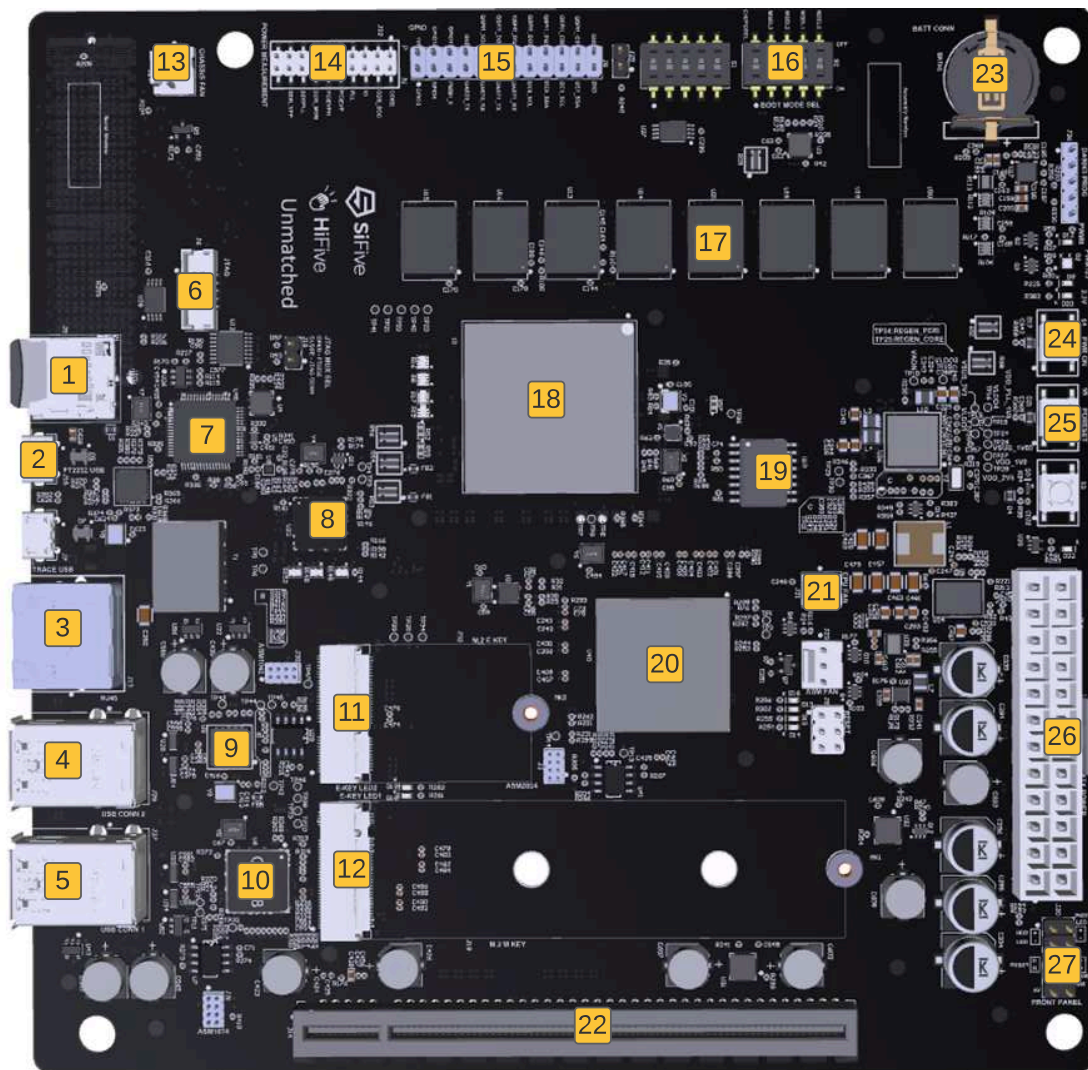

**Figure 1:** HiFive Unmatched Components

**Table 1:** HiFive Unmatched Components

1	microSD Card Slot	14	Current Monitor
2	microUSB Connector	15	GPIO Header
3	RJ45 Ethernet Connector	16	Bootmode DIP Switch
4	x2 USB Type-A Connector	17	DDR4 Memories
5	x2 USB Type-A Connector	18	FU740 SoC
6	JTAG Header	19	32MB QSPI Flash
7	UART – USB Controller	20	PCIe Switch
8	Ethernet PHY	21	CPU Fan Header
9	PCIe - USB Bridge	22	x16 PCIe Connector
10	USB Hub	23	CR1220 Battery Connector
11	M.2 E Key Connector for WiFi/Bluetooth	24	Power Pushbutton
12	M.2 M Key Connector for NVMe SSD	25	Reset Pushbutton
13	Case Fan Header	26	ATX Power Connector
		27	Front Panel Connector

# 2

## Hardware

### 2.1 Packaged Components

The HiFive Unmatched Development Kit comes packaged with the following components:

1. The HiFive Unmatched Board
2. A 32GB SD Card with pre-loaded software (for **1** in Figure 1)
3. A M.2 Screw Package (for use with the optional NVMe SSD drive and WiFi/Bluetooth cards)
4. Case mounting hardware for a mini-ITX compatible case
5. Ethernet cable for the RJ45 connector (connects to **3** in Figure 1)

### 2.2 Required Hardware

Using the HiFive Unmatched Development Kit requires the following parts which are not included in the kit:

- **ATX Power Supply Unit (PSU):**  
Power to the board is provided by an ATX Power Supply via a 24-pin ATX Power Connector, see **26** in Figure 1. The PSU must be rated at a minimum of 150W.

#### Note

If the user is implementing a PCIe expansion device, please reference the manufacturer specifications and power supply recommendations for the device before selecting a PSU.

- **MicroUSB Cable:**  
A micro USB cable is required use the terminal feature of the HiFive Unmatched.

## 2.3 Optional Hardware

The following parts or components are recommended to supplement the HiFive Unmatched board.

- **Mini-ITX Compatible Case:**  
If the user would like to house the HiFive Unmatched board in a case, a mini-ITX compatible case will be required.
- **M.2 for NVMe SSD and WiFi/Bluetooth Cards:**  
The HiFive Unmatched board is enabled to support M.2 for an NVMe SSD drive and a Wi-Fi/Bluetooth card (slotted to **12** and **11** respectively in Figure 1).
- **PCIe Expansion Cards:**  
The HiFive Unmatched provides support for PCI Express up to Gen3 x8 via a PCIe x16 slot (**22** in Figure 1). Any PCIe expansion cards must be acquired through a third-party vendor.
- **Keyboard and Mouse:**  
If a graphical user interface configuration is selected, then a keyboard and mouse may be required. These may be plugged into the Type-A USB ports (**4** and **5** in Figure 1).

## 2.4 Qualified Vendor List

Following third party components are being used and qualified by SiFive to work out of the box with the Unmatched board.

- **ATX Power Supply:**  
If the user is utilizing a PCIe expansion card, consult the manufacturer specification sheet to identify the wattage needed to power the device before buying a power supply unit. SiFive has tested the HiFive Unmatched board using the FSP Mini ITX Solution/Flex ATX 250W power supply (**part# FSP250-50FGBBI(M)**) without any PCIe expansion card.
- **PCIe Expansion Cards:**  
An AMD RX 500-series GPU is recommended to enable graphical processing on the HiFive Unmatched. After selecting a GPU, consult GPU system requirements and specifications documentation for the PSU wattage requirements.
- **Bluetooth and WiFi Card:**  
An Intel<sup>®</sup> Wireless-AC 9260 Network adapter - M.2 2230 - 802.11ac, Bluetooth 5.0 (**part# 9260.NGWG.NV**) was tested to enable WiFi on the board. An Antenna and cable will be required to use M.2 adapter listed above. SiFive has qualified and tested the HUYUN IPEX MHF4 Antenna WiFi Cable for NGFF/M.2 WiFi/WLAN Card Module (**part# 8541551175**).
- **NVMe SSD:**  
SiFive has qualified and tested Samsung 970 EVO Plus MZ-V7S250B NVMe SSD drive (**part# MZ-V7S250B/AM**).



## 2.5 Problematic Hardware



**Figure 2:** SanDisk A2 SD Card

SanDisk™ microSD cards that are marked with "A2" (see Figure 2 above) been identified as causing errors and crashes when connected to the HiFive Unmatched board. Other Sandisk microSD cards that do not have the "A2" labeling function without problems. Please avoid using the microSD cards marked with "A2" to load the HiFive Unmatched firmware.

# 3

## Board Setup

The following chapter provides the steps necessary to setup the HiFive Unmatched development board. Figure 3 shows the proper board setup, where the board is connected to a host machine and network.

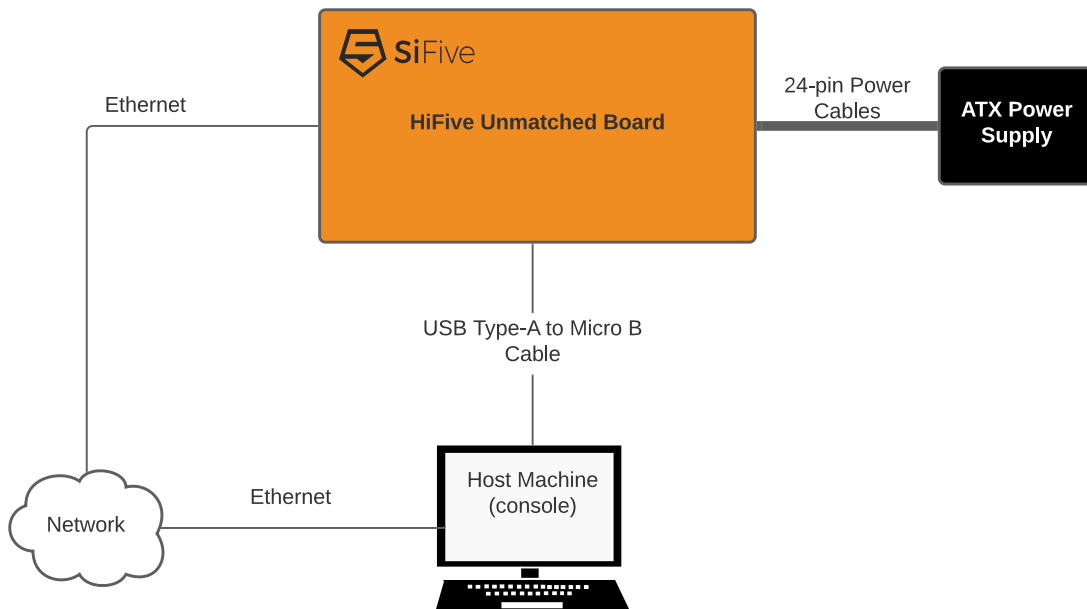

**Figure 3:** *HiFive Unmatched System Block Diagram*

### 3.1 Initial Setup

Before powering the board, consider the following requirements.

- **Boot Mode Select DIP Switch:**  
The Bootmode Select DIP switch (see **16** in Figure 1) should be set to the following:  
MSEL[3:0] – [ON, OFF, ON, ON] or 1011.

**Note**

On HiFive Unmatched Version 2 boards, the silk screen which describes the orientation of the Boot Mode Select switch is incorrect. Version 2 can be identified from the Board Assembly Number Label on the board, HF105-ASSY-2A0, where number 2 indicates Version 2. Please carefully match the orientation shown in Figure 4 to ensure that the Unmatched Board boots from the SD card.

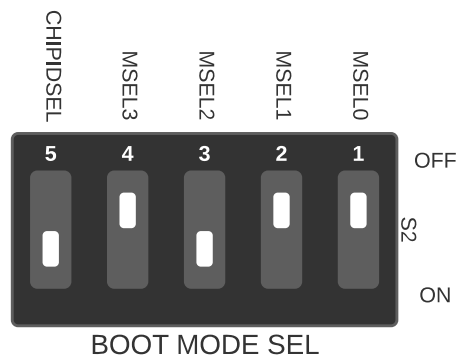

**Figure 4:** Boot Mode Select switch with default setting (MSEL = 4b'1011)

**Table 2:** Boot Mode Select Configuration Settings

MSEL[3:0]	FSBL Location	Access Method	SPI Width
4b'0101	QSPI0 Flash	Memory mapped	X1
4b'0110	QSPI0 Flash	Memory mapped	X4
4b'0111	QSPI1 Flash	Memory mapped	X4
4b'1000	QSPI1 SD Card	Bit-banged	X1
4b'1001	QSPI2 Flash	Bit-banged	X1
4b'1010	QSPI0 Flash	Memory mapped	X4
<b>4b'1011 (Default)</b>	<b>QSPI2 SD Card</b>	<b>Bit-banged</b>	<b>X1</b>
4b'1100	QSPI1 Flash	Bit-banged	X1
4b'1101	QSPI1 Flash	Memory mapped	X4
4b'1110	QSPI0 Flash	Bit-banged	X1
4b'1111	QSPI0 Flash	Memory mapped	X4

- **Front Panel Connectors:**

If the user is mounting the HiFive Unmatched board a mini-ITX case, connect the front panel header wires to the front panel connector (see **27** in Figure 1).

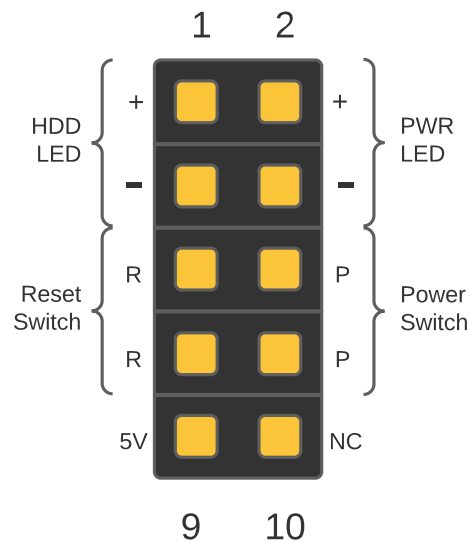

**Figure 5:** Front Panel Connector

**Table 3:** Front Panel Connections

1	HDD LED	2	Power LED
3	HDD LED -	4	Power LED -
5	Reset Switch	6	Power Switch
7	Reset Switch	8	Power Switch
9	+5V	10	No connection

## 3.2 Connecting to the Power Supply

First, connect the ATX power supply 24-pin connector to ATX header (**26** in Figure 1) on the board. Some 24-pin ATX power connectors are made of 20 pin and 4 pin connectors that must be merged to ensure a good connection. Consider Figure 6.

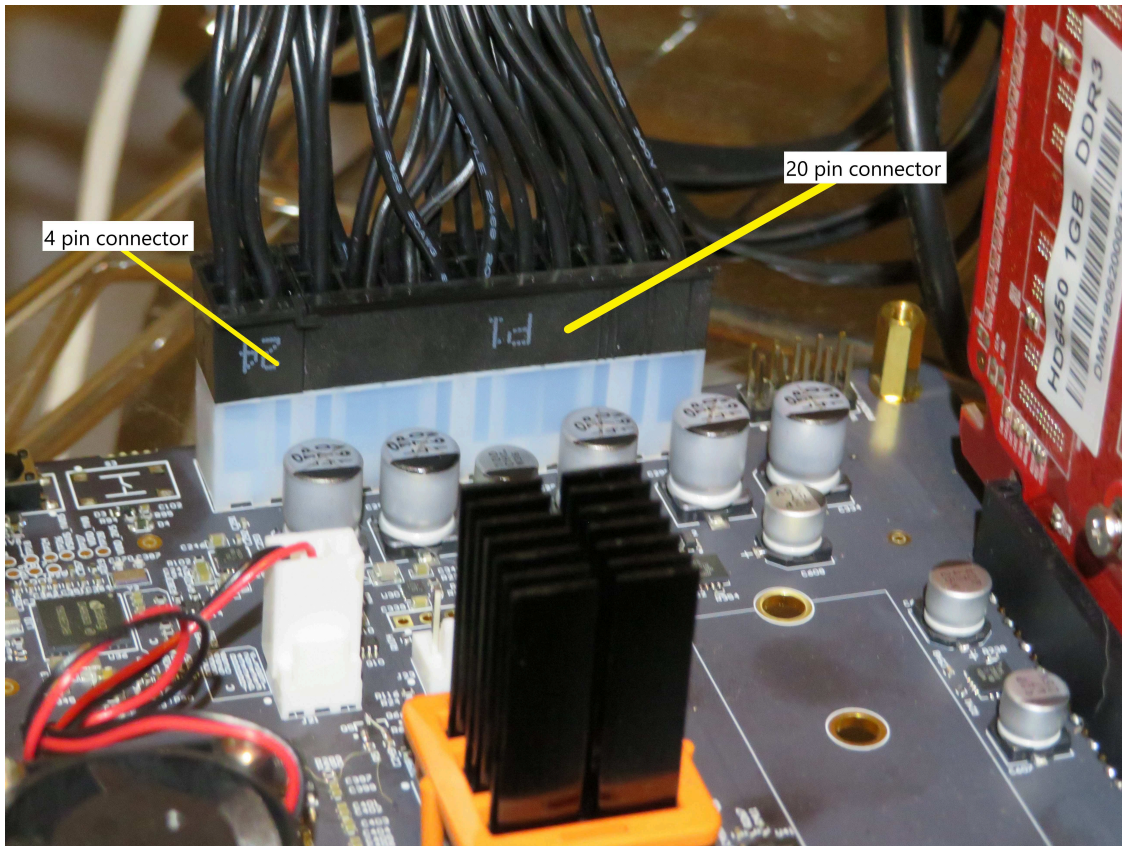

**Figure 6:** ATX Connection

#### Note

Care must be taken not to excessively flex the board when connecting or disconnecting the ATX Power Connector. Note that the figure above is from the first version of the board. Later versions of the fan header position the red cable on the left and the black cable on the right.

Then, connect USB to microUSB cable to the microUSB connector (see **2** in Figure 1).

### 3.3 Slotting the MicroSD Card

The HiFive Unmatched kit comes packaged with a preloaded microSD card. Connect this microSD card to the microSD card slot (see **1** in Figure 1).

## 3.4 Checking the Fan Connection

The HiFive Unmatched board comes packaged with the CPU fan installed. Ensure that the CPU fan cables are firmly connected to the CPU Fan Header (**21** in Figure 1) before turning ON the board.

## 3.5 Powering the Board

Then, power the ATX power supply. The power supply might have a switch that needs to be flipped on. After setting up the power supply, follow the steps below to power the board ON and OFF.

### 3.5.1 Turn ON Power to Board

If the board is not connected to a PC case via the front panel header, power is switched on by an on-board pushbutton. To turn on the board, press the power pushbutton (**24** in Figure 1) briefly. The on-board power supply will then turn on. Power LEDs will illuminate indicating that the ATX power supply is turned ON and power is being regulated from the on-board power supply.

Alternatively, if the board is connected to the case, connect the front panel wires as shown in Table 3 and press the power button on the PC case to turn ON the HiFive Unmatched board.

### 3.5.2 Turn OFF Power to Board

To turn off the board, press and hold the power pushbutton (**24** in Figure 1) for about four seconds. This will turn off the on-board power regulator, shutting off the board. Power OFF on the board is indicated by the fan stopping and LEDs shutting off.

Alternatively, if the board is connected to the case, push and hold the power button on the case to turn OFF the HiFive Unmatched board.

## 3.6 Connecting IOs to the Board

After setting up power to the board, connect IO devices as necessary.

# 4

## Boot and Run

The user can connect to the HiFive Unmatched board over USB-UART Serial Console.

### 4.1 Connecting with USB Console

With a microUSB cable connected to the HiFive Unmatched, you can access the console. The console both shows the linux boot process and can be used to log into the device.

From macOS, run:

```
sudo screen -L /dev/tty.usbserial-*01 115200
```

From Linux, run:

```
sudo screen -L /dev/serial/by-path/*-port0 115200
```

For the commands above, the "-L" flag enables automatic output logging. The default file name for this logfile is "screenlog.0". This logfile will be created and appended to in the user's working directory. If major issues occur, such as kernel crashes and boot stage errors, this logfile can be used to help the SiFive support team identify the source of an error. More information about the "-L" flag is available in the manual page (command: `man screen`).

Alternatively, the user can use `minicom` and `picocom` commands to access the console.

Hit enter a few times to see the login prompt. Username `root`, password `sifive`.

To quit screen, hit `Control-a, \, y`. If you do not quit properly, you can end up with multiple screens running at the same time. This manifests as lost characters both sent and received.

#### 4.1.1 Installing USB-UART Drivers on macOS

To use the USB-UART serial console on macOS, the user may need to install an external driver for FTDI chips.

1. Head over to the FTDI Chip drivers page:  
<https://www.ftdichip.com/Drivers/VCP.htm>
2. Scroll down until you reach the table of download links and select your operating system.
3. Download the selected driver.
4. Open the installer DMG file.
5. Open the FTDIUSBSerial.pkg file. This will prompt an installer dialog box. Continue with installation and agree to terms of software license agreement to install the drivers.
6. Enter your admin password.
7. Click "Install Software".
8. The drivers should be installed, and the user can now access the HiFive Unmatched console via USB-UART.

#### 4.1.2 Setting up the Terminal on Windows

The following section describes getting started with the HiFive Unmatched terminal on Windows using PuTTY.

After plugging your microUSB cable to the microUSB connector (**2 in Figure 1**), connect the USB to your host machine. The HiFive Unmatched board should then appear in your Device Manager, as shown in Figure 7. Note that the COM port number may be different for each environment.

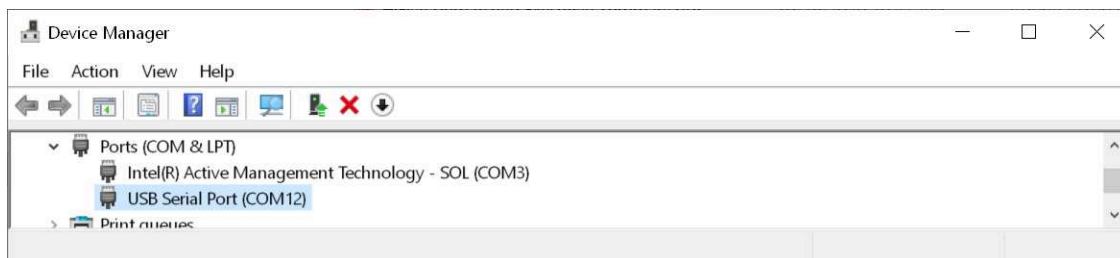

**Figure 7:** Device Manager COM Ports

Right click on the "USB Serial Port" and select "Properties" from the dropdown menu. This should display the following, as shown in Figure 8. Note that "Manufacturer: FTDI" is expected.



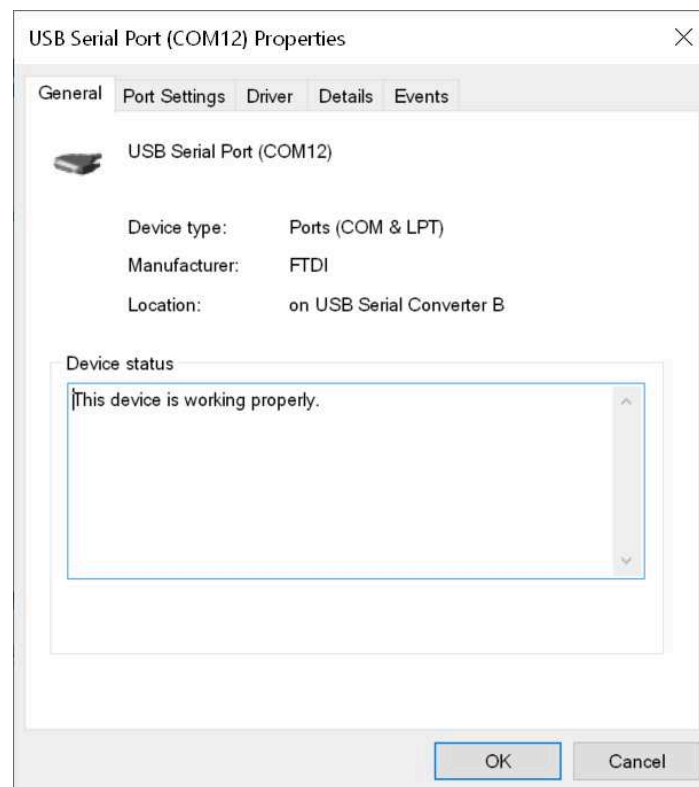
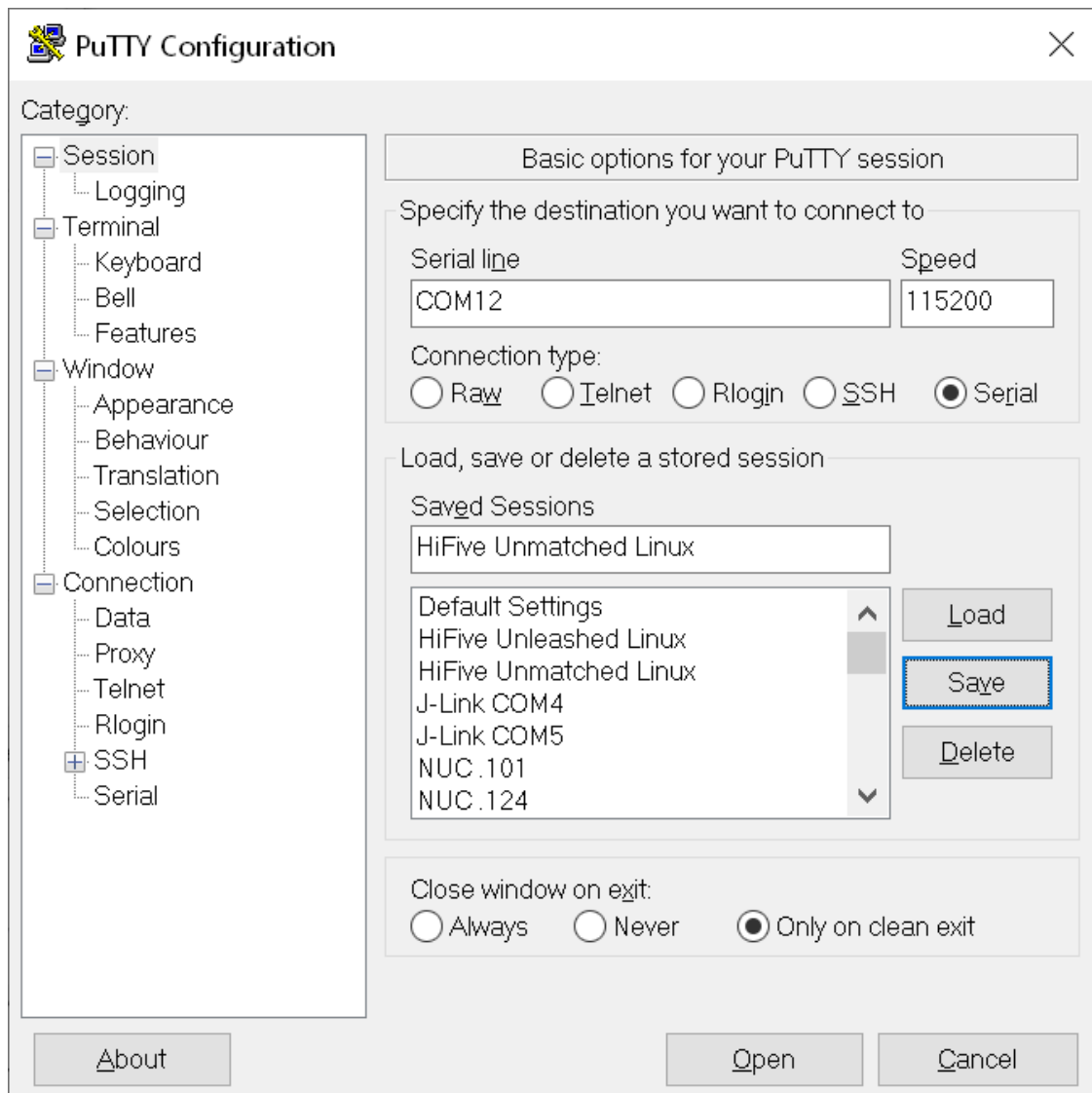

**Figure 8:** Serial Port Properties

Then, download and install the latest release of PuTTY:  
<https://www.chiark.greenend.org.uk/~sgtatham/putty/latest.html>

Then, configure PuTTY as shown in Figure 9.

1. Select "Serial" connection type
2. Select Serial line for the COM port the HiFive Unmatched board is connected to as shown in the Device Manager.
3. Select Speed of 115200
4. Click the "Open" button



**Figure 9:** PuTTY Configuration

## 5

# Support for HiFive Unmatched

Join the SiFive forums to ask questions and receive support for the HiFive Unmatched development board: <https://forums.sifive.com/c/hifive-unmatched/16>.

For supplemental information about HiFive Unmatched and the latest versions of the supporting documentation, visit: <https://www.sifive.com>.

For direct questions, contact your SiFive representative.