

GUHRING

The Tool Company

High-Performance Solid Carbide End Mill Catalog



3rd Edition



USA Headquarters
Brookfield Distribution Center, manufacturing and
Reconditioning Facility
1445 Commerce Avenue
Brookfield, WI 53045
Tel (262) 784-6730 (800) 776-6170
Fax (262) 784-9096



California Distribution Center and Reconditioning Facility
15581 Computer Lane
Huntington Beach, CA 92649
Tel (714) 841-3582
Fax (800) 877-7202

Dear customers,

Highest productivity, excellent economic efficiency and optimum machining results are the principles to which we steer our products and services towards. At Guhring this is achieved with great success by more than of 5,000 employees world-wide. Their objective is customer satisfaction and this makes Guhring the leading world wide manufacturer of rotary cutting tools.

YOU BENEFIT IN MANY WAYS:

Pooled expertise

With Guhring tools you can rely on the tool material, the geometry and the coating – the essential parameters for the efficiency of a precision tool – to be perfectly coordinated.

Our own carbide production, our own machine and equipment construction, our own coating technology as well as our own development departments ensure we maintain technological leadership in rotary cutting tools. Within the framework of our special tool production we develop optimized tools with an excellent price-performance-ratio for our customers.



Connecticut Reconditioning Facility
121 W Dudley Town Rd.
Bloomfield, CT 06002
Tel (860) 216-5948
Fax (860) 519-5819



Michigan Manufacturing and Reconditioning Facility
29550 W.K. Smith Rd. Suite B
New Hudson, MI 48165
Tel (248) 486-3783
Fax (248) 486-0046

Trend-setting innovations

In excess of 600 granted patents world-wide are proof of our capability for innovation. Countless Guhring standards, as for example, the TiN-coating, the HSK or MQL technology have set trends in the tooling industry.

With the new nano-Si coating – one of the hardest nitride coatings on the market – new tools for the efficient machining of composite materials and highly accurate hydraulic chucks for the clamping of the smallest shank diameters we provide new technologies for the future.

Made-to-measure services

Customer specific tool management concepts combine process planning, logistics, tool application and refurbishment modules together tailor-made to suit your requirements. The new generation of Guhring tool vending systems from the simple workshop solution to the model for complex process chains completes the entire range of tool logistics.

Your partner world-wide

In order for you to benefit from the advantages of our tooling solutions all over the world in close vicinity to your production, Guhring is represented internationally by 28 production plants, 47 service centers, 46 sales companies and countless sales and marketing partners. World-wide our uniform standards ensure that you can always and everywhere rely on the same high Guhring quality.

It would be our pleasure to be allowed to continue to convince you of our efficiency!

Yours sincerely,

Dr. Jörg Gühring

A global company supporting the
global economy



28 production plants
47 service centers
46 sales companies

www.guhring.com

TWIST DRILLS



GUN DRILLS



THREADING TOOLS



MILLING CUTTERS



REAMERS



COUNTERSINKS



PCD AND CBN TOOLS



TOOL CLAMPING DEVICES

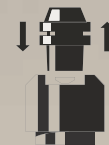

Greater performance.
Longer tool life.

Added value.



A

TiAlN



A a

Super A
nano-A



C

TiCN



Cb

Carbo



D

Crystal

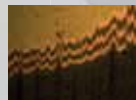

F

FIREX
nano-FIREX



Y

nano-Si

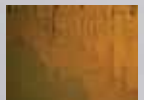

S

TiN

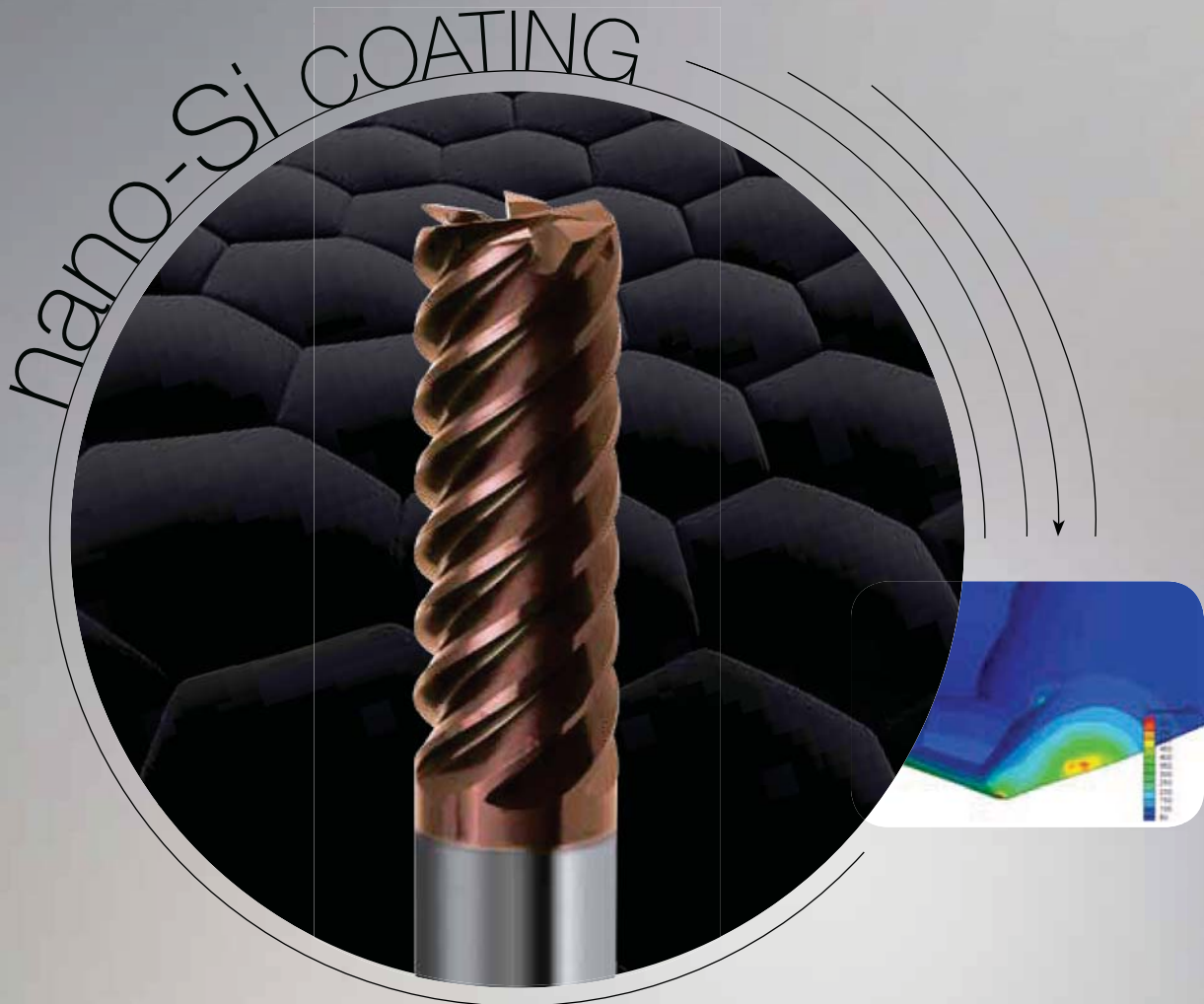

GUHRING is a renowned specialist for application optimized high-performance coatings. As the first tool manufacturer world-wide to provide tools with a TiN-coating in 1980 by continuous improvement we have made them considerably more wear-resistant. To date, GUHRING consistently keeps setting pioneering tooling technology trends. The extremely hard nano-Si coating or the ultra-thin nano-A coating are only a few of the many examples.

Our world-wide service centers work to uniform standards and processes to ensure that our customers' tools can always be re-coated one hundred percent true to the original. Plus: We also coat tooling products from other suppliers as well as functional components from a wide range of industries.

The result: Increased performance and longer tool life.

You too can rely on optimal tool wear protection made by GUHRING.

Quality down to the last detail.



Whether especially high degree of hardness, pronounced bending strength, extreme toughness or extra low reactivity is required – we can produce the perfect carbide grade that exactly matches your individual requirements thanks to our own carbide development and production. For lasting optimized machining results – even with demanding tasks such as tapping in steel.

Additionally: We also produce carbide blanks often with a complex geometry as the basis for sophisticated special tools. For example, this includes rods up to a length of 2000 mm or complex blanks with multiple steps as well as rods for multi-fluted tools with up to five spiral coolant ducts.

MADE - TO - MEASURE
QUALITY
FOR MADE - TO - MEASURE
TOOLS.



In short: GUHRING can provide a perfect carbide solution for every industry and every area of application.

Guaranteed perfection for you.



PRODUCTION AND SERVICE CENTERS

GERMANY

Albstadt I
 Albstadt II
 Albstadt III
 Berlin/Precision Tools Production
 Berlin/Carbides
 Geislingen
 Gosheim
 Hörselberg/Eisenach
 Markt Erlbach
 Mindelheim
 Röhrsdorf/Chemnitz
 Saarbrücken
 Sigmaringen-Laiz
 Veldhoven/NL

WORLD-WIDE

Australia
 Brazil
 Diadema
 Joinville
 Changzhou
 China
 Liaoning
 China
 Liuzhou
 China
 Hubei
 France
 Great Britain
 India
 Bangalore
 India
 Pune
 India
 Gurgaon
 Indonesia
 Ireland
 Italy
 Japan
 Korea
 Chungcheongnam-do
 Rizhao
 Korea
 Choongnam
 Korea
 Ulsan City
 Korea
 Mexico
 Incheon
 Netherlands
 Austria
 Poland
 Dabrowa Górnicza
 Poland
 Bielsko Biala
 Rumania
 Russia
 Sweden
 Spain

South Africa
 Taiwan
 Thailand
 Czech Republic
 Turkey
 Istanbul
 Turkey
 Izmir
 Turkey
 Ankara
 Hungary
 USA
 Brookfield
 USA
 New Hudson
 USA
 Huntington Beach
 USA
 Bloomfield
 Vietnam
 Belarus



SALES COMPANIES ●

- Argentina
- Australia
- Baltic States
- Belgium
- Brazil
- Bulgaria
- China
- Denmark
- Finnland
- France
- France Alsace
- France Metz-Tessy
- Great Britain
- India
- Indonesia
- Italy
- Japan
- Canada
- Korea
- Malaysia
- Mexico
- Netherlands
- Austria
- Philippines
- Poland
- Rumania
- Russia
- Sweden
- Switzerland
- Singapore
- Slovakia
- Slovenia
- Spain
- Spain Barcelona
- Spain Madrid
- South Africa
- Taiwan
- Thailand
- Czech Republic
- Turkey
- Ukraine
- Hungary
- USA
- USA Brookfield
- USA New Hudson
- Vietnam
- Belarus

SALES AND MARKETING PARTNERS ●

- Egypt
- Algeria
- Bolivia
- Chile
- Denmark
- Greece
- Hong Kong
- Italy
- Columbia
- Marocco
- Mauritius
- New Zealand
- Norway
- Pakistan
- Peru
- Philippines
- Portugal
- South Africa
- Thailand
- Tunesia
- Venezuela
- Vietnam



Brookfield, WI

For more than 35 years, Guhring Inc. (USA) has brought the innovations of industry-leading Guhring technology, products and technical support to the United States. **One company, one brand, same name** known throughout North America for quality for over three decades.

Guhring is also the leader in tool reconditioning services with the opening of our fourth USA facility in Bloomfield, CT. Combined with our reconditioning and coating facilities in Brookfield, WI; New Hudson, MI; and Huntington Beach, CA, Guhring is the only company that can provide nationwide coverage to support

their customers. Visit www.guhring.com for contact information and request a quotation on-line. It is quick and easy to use and will extend your tool life and increase your productivity.

Need an economical solution?

A category of drills, taps and variable helix carbide end mills called **Guhring Select** tools is for you. These tool series are manufactured from the same materials and to the same quality and exacting tolerances that you expect from Guhring. Each series has been selected because of its versatility in a wide range of materials and machining operations, to provide you with a full compliment of quality drill, tap and milling options at an economical price.

Simplify your tool search by choosing **Guhring Select**. These tools offer a full range of economical, quality, machining solutions. From the production facility to the small prototype machine shop, there is a Guhring Select tool that will suit your needs.

Look for the **Guhring Select** logo to quickly identify these economical tooling choices.

GUHRING ✓ Select



RF 100 / Variable Helix

Section 1

Page 18

Finishers



Roughers



Ball Nose



Diamond-Tech

Section 2

Page 66

PCD End Mills



Composite Routers



Tech-Line / Material Specific

Section 3

Page 74

Finishers



Roughers



Mold / Die



Pro-Line / General Purpose

Section 4

Page 118

Finishers



Ball Nose



Pictograms

Tool material

carbide

Solid carbide finest grain (carbide-UF)

to DIN

to Guhring standard

Type

W

N

NH

H

HF

NF

WF

NRf

HR

WR

SF

F

VA

VA/NF

A

A/WF

Ti

U

U/HF

Application range to DIN 1835

Helix angle



Size of helix angle / number of different helix angles

No. of cutting edges



Number of cutting edges

Cutting edge corner









Size of corner chamfer or radius, dependent on diameter

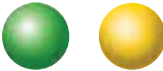

Shank form



to DIN 6535

Steel		<p>Free Machining & Low Carbon Steels - up to 28 HRc Examples: 1006, 1008, 1015, 1018, 1020, 1022, 1025, 1117, 1140, 1141, 11L08, 11L14, 1213, 12L13, 12L14, 1215, 1330</p> <p>Medium Carbon & High Carbon Steels, Alloy Steels & Easy to Machine Tool Steels - up to 38 HRc Examples: 1030, 1035, 1040, 1045, 1050, 1052, 1055, 1060, 1085, 1095, 1541, 1551, 9255, 2515, 3135, 3415, 4130, 4137, 4140, 4150, 4320, 4340, 4520, 5015, 5115, 5120, 5132, 5140, 5155, 6150, 8620, 9262, 9840, 52100, O1, O2, O6, S2, W1 to W310</p>
Stainless Steel		<p>Stainless Steel - Easy to Machine up to 28 HRc Examples: 430F, 301, 303, 410, 416 Annealed, 420F, 430, 430F</p> <p>Stainless Steel - Moderately Difficult up to 28 HRc Examples: 301, 302, 303 High Tensile, 304, 304L, 305, 420, 15-5PH, 17-4PH, 17-7PH</p> <p>Stainless Steel - Difficult to Machine over 28 HRc Examples: 302B, 304B, 309, 310, 316, 316B, 316L, 316Ti, 317, 317L, 321, PH13-8MO, Nitronic</p>
Tool Steel & High Tensile Steels		<p>Tool Steels & Die Steels up to 44 HRc Examples: O7, M1, M2, M3, M4, M7, T1, T2, T4, T5, T8, T15, A2, A3, A6, A7, H10, H11, H12, H13, H19, H21, L3, L6, L7, P2, P20, S1, S5, S7, 52100, A 128, D2, D3, D4, D5, D7</p> <p>Hardened Steels up to 54 HRc Examples: Carbon and Alloy Steels, Tool & Die Steels</p> <p>Hardened Steels up to 60 HRc Examples: Carbon and Alloy Steels, Tool & Die Steels</p>
Cast Iron		<p>Cast Iron - Gray CG up to 180 HB 30 Examples: ASTM A48, CLASS 20, 25, 30, 35, SAE J431C, GRADES G1800, G3000, G3500, GG 10, 15, 20, 25, 30, 35, 40</p> <p>Cast Iron - Ductile & Malleable CGI above 180 HB 30 Examples: 60-40-18, 65-45-12, D4018, D4512, D5506, 32510, 35108, M3210, M4504, M5503, 250, 300, 350, 400, 450</p>
Aluminum		<p>Aluminum, Al-wrought alloys, Al-alloys Examples: 2024, 6061, 7075, 1050, 6351, 5005, 2017, 7075</p> <p>Aluminum-cast alloys Examples: High Silicon - A380, A390, Castings, 3.2131 G-AISI5Cu1, 3.2153 G-AISI7Cu3, 3.2573 G-AISI9, 3.2581 G-AISI12, 3.2583 G-AISI12Cu, - G-AISI12CuNiMg</p>
Titanium & Nickel Alloys		<p>High-Temperature Alloys Examples: Nimonic, Inconel, Monel, Hastelloy</p> <p>Titanium Alloys Examples: 6Al-4V, 5Al-2.5 Sn, 6Al-2Sn-4Zr-6Mo, 3Al-8V-6Cr4Mo-4Zr, 10V-2Fe-3Al, 13V-11Cr-3Al</p>
Hardened Materials		<p>Hardened Steels up to 54 HRc Examples: Carbon and Alloy Steels, Tool & Die Steels</p> <p>Hardened Steels up to 60 HRc Examples: Carbon and Alloy Steels, Tool & Die Steels</p>

Application			Slot drilling  1 x d	Roughing  0.3-0.8 x d	Finishing  > 0.1 x d	Super finishing  0.1 x d
Material/ Application group	Hardness tensile strength	Example material	Rigid conditions:  - good cooling - sufficient performance - short-chipping	Unstable conditions:  - standard cooling - average performance - medium- to long-chipping	Finishing: 	
Steel 	up to 28 HRc	1045 / 5115	RF 100 F Series #3078 Page 39	RF 100 VA/NF Series #3081 Page 47	RF 100 S/F Series #3115 Page 63	
	above 28 HRc	4140	RF 100 U Series #3114 Page 27	RF 100 U/HF Series #3082 Page 34		
Stainless steel 	up to 28 HRc	304 / 303	RF 100 VA Series #3080 Page 41	RF 100 VA/NF Series #3081 Page 47		
	above 28 HRc	316Ti	RF 100 F Series #3078 Page 39	RF 100 VA/NF Series #3081 Page 47		
Cast iron 	up to 180 HB 30	Gray Cast	RF 100 F Series #3078 Page 39	RF 100 U/HF Series #3082 Page 34		
	above 180 HB 30	GGG / GGT / GGv ductile	RF 100 U Series #3114 Page 27	RF 100 U/HF Series #3082 Page 34		
Aluminium 	up to 3% Si	Wrought Alloys	RF 100 A Series #4265 Page 54	RF 100 A/WF Series #4266 Page 51	RF 100 A Series #3077 Page 53	
	above 3% Si	Cast Alloys	RF 100 F Series #4265 Page 54	RF 100 A/WF Series #4266 Page 51	RF 100 F Series #3078 Page 39	
Ti- special alloys 	Ti-basis	TiAl6V4 Inconel 625	RF 100Ti Series #3876 Page 57	RF 100 U/HF Series #3082 Page 34	RF 100 S/F Series #3115 Page 63	
	Ni-basis	Inconel 728	RF 100 F Series #3078 Page 39	RF 100 VA/NF Series #3081 Page 47		
Hardened steel H	up to 52 HRC	H11	RF 100 U Series #3114 Page 27	RF 100 U/HF Series #3082 Page 34		
	above 52 HRC	D2	RF 100 H Series #3896 Page 65	—	RF 100 H Series #3895 Page 65	

Application			Slot drilling  1 x d	Roughing  0.3-0.8 x d	Finishing  > 0.1 x d	Super finishing  0.1 x d
Material/ Application group	Hardness tensile strength	Example material	Rigid conditions:  - good cooling - short-chipping	Unstable conditions:  - standard cooling - medium- to long-chipping	Finishing: 	
Steel 	up to 28 HRc	1045 / 5115	Uni-Pro Series #3153 Page 133	Rough-Tech 48 Series #3188 Page 99	Finish-Tech 50 Series #3179 Page 103	
	above 28 HRc	4140	Aero-Tech Series #3173 Page 85	Aero-Rough 48 Series #3097 Page 95		
Stainless steel 	up to 28 HRc	304 / 303	Uni-Pro Series #3153 Page 133	Aero-Rough 48 Series #3097 Page 95		
	above 28 HRc	316Ti	Aero-Tech Series #3173 Page 85	Aero-Rough 48 Series #3097 Page 95		
Cast iron 	up to 180 HB 30	Gray Cast	Uni-Pro Series #3153 Page 133	Aero-Rough 48 Series #3097 Page 95		
	above 180 HB 30	GGG / GGT / GGv ductile	Aero-Tech Series #3173 Page 85	Aero-Rough 56 Series #3098 Page 96		
Aluminium 	up to 3% Si	Wrought Alloys	Alumi-Tech Series #3174 Page 89	Rough-Tech ALU Series #3184 Page 93	Alumi-Tech Series #3177 Page 91	
	above 3% Si	Cast Alloys	Aero-Tech Series #3173 Page 85	Rough-Tech ALU Series #3184 Page 93	Uni-Pro Series #3153 Page 133	
Ti- special alloys 	Ti-basis	TiAl6V4 Inconel 625	Aero-Tech Series #3173 Page 85	Aero-Rough 56 Series #3098 Page 96	Finish-Tech 50 Series #3179 Page 103	
	Ni-basis	Inconel 728	Uni-Pro Series #3153 Page 133	Aero-Rough 48 Series #3097 Page 95		
Hardened steel H	up to 52 HRC	H11	Aero-Tech Series #3173 Page 85	Aero-Rough 56 Series #3098 Page 96		
	above 52 HRC	D2	—	Rough-Tech 56 Series #3189 Page 101	Finish-Tech 62 Series #3182 Page 107	

HIGH-PERFORMANCE
VARIABLE HELIX
END MILLS

BRF















































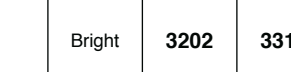

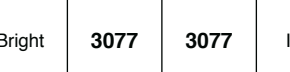

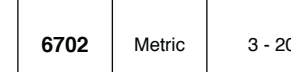

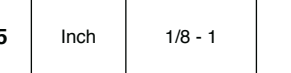

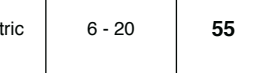















Application			Slot drilling  1 x d	Roughing  0.3-0.8 x d	Finishing  > 0.1 x d	Super finishing  0.1 x d
Material/ Application group	Hardness tensile strength	Example material	Rigid conditions:  - good cooling - sufficient performance - short-chipping	Unstable conditions:  - standard cooling - average performance - medium- to long-chipping	Finishing: 	
Steel 	up to 28 HRc	1045 / 5115	RF 100 F Series #3078 Page 39	RF 100 VA/NF Series #3081 Page 47	RF 100 S/F Series #3115 Page 63	
	above 28 HRc	4140	RF 100 U Series #3114 Page 27	RF 100 U/HF Series #3082 Page 34		
Stainless steel 	up to 28 HRc	304 / 303	RF 100 VA Series #3080 Page 41	RF 100 VA/NF Series #3081 Page 47		
	above 28 HRc	316Ti	RF 100 F Series #3078 Page 39	RF 100 VA/NF Series #3081 Page 47		
Cast iron 	up to 180 HB 30	Gray Cast	RF 100 F Series #3078 Page 39	RF 100 U/HF Series #3082 Page 34		
	above 180 HB 30	GGG / GGT / GGv ductile	RF 100 U Series #3114 Page 27	RF 100 U/HF Series #3082 Page 34		
Aluminium 	up to 3% Si	Wrought Alloys	RF 100 A Series #4265 Page 54	RF 100 A/WF Series #4266 Page 51	RF 100 A Series #3077 Page 53	
	above 3% Si	Cast Alloys	RF 100 F Series #4265 Page 54	RF 100 A/WF Series #4266 Page 51	RF 100 F Series #3078 Page 39	
Ti- special alloys 	Ti-basis	TiAl6V4 Inconel 625	RF 100Ti Series #3876 Page 57	RF 100 U/HF Series #3082 Page 34	RF 100 S/F Series #3115 Page 63	
	Ni-basis	Inconel 728	RF 100 F Series #3078 Page 39	RF 100 VA/NF Series #3081 Page 47		
Hardened steel H	up to 52 HRC	H11	RF 100 U Series #3114 Page 27	RF 100 U/HF Series #3082 Page 34		
	above 52 HRC	D2	RF 100 H Series #3896 Page 65	—	RF 100 H Series #3895 Page 65	

Type	Helix angle	Number of teeth	Length	Tool description	Tool material	Gurhing no.	Gurhing no.	Unit	Diameter Range	Page
					Surface finish	HA	HB			
RF 100 U - high-performance end mills center cutting					carbide					
N	35° 38°	4			FIREX®	3113	3099	Inch	3/16 - 1	27
N	35° 38°	4			FIREX®	6706	3731	Metric	6 - 20	29
N	35° 38°	4			FIREX®	3114	3100	Inch	1/8 - 1 1/4	27
N	35° 38°	4			FIREX®	3736	3732	Metric	4 - 25	29
N	35° 38°	4			FIREX®	3872	3873	Metric	6 - 25	29
N	35° 38°	4			FIREX®	3079	3079	Inch	1/4 - 1	27
N	35° 38°	4			FIREX®	3837	3838	Metric	6 - 20	29
N	35° 38°	4			FIREX®	3839	3871	Metric	6 - 20	29
N	35° 38°	4			FIREX®	4250	4250	Inch	3/16 - 1	27
N	35° 38°	4			FIREX®	4251	4251	Inch	3/16 - 1	27
N	35° 38°	4			FIREX®	4252	4252	Inch	1/4 - 1 1/4	27
N	35° 38°	4			FIREX®		4253	Inch	1/2 - 1	27
N	35° 38°	4			FIREX®	3627		Metric	10 - 25	29
RF 50 - high-performance end mills center cutting					carbide					
N	40°	4			FIREX®	3095	3095	Inch	3/16 - 1	37
N	40°	4			FIREX®	3096	3096	Inch	3/16 - 1	37

Type	Helix angle	Number of teeth	Length	Tool description	Tool material Surface finish	Gurthing no.	Gurthing no.	Unit	Diameter Range	Page
						HA	HB			
RF 100 U - high-performance end mills (3-fluted) with center cutting					carbide					
N	41° 43° 45°	3			FIREX®	3893	3894	Metric	3 - 16	33
N	41° 43° 45°	3			FIREX®	3891	3892	Metric	3 - 20	33
N	41° 43° 45°	3			FIREX®	4255	4255	Inch	1/8 - 1	32
N	41° 43° 45°	3			FIREX®	4254	4254	Inch	1/8 - 1	32
RF 100 U/HF - high-performance roughing end mills center cutting					carbide					
HF	30° 32°	4			FIREX®	3507	3508	Metric	6 - 25	35
HF	30° 32°	4			FIREX®	3082	3082	Inch	1/4 - 1	34
HF	30° 32°	4			FIREX®	4256	4256	Inch	1/4 - 1	34
HF	30° 32°	4			FIREX®	3509	3522	Metric	6 - 20	35
HF	30° 32°	4			FIREX®	3598	3600	metric	6 - 20	35
RF 100 F - high-performance end mills center cutting					carbide					
NH	40° 42°	4			FIREX®	3629	3630	Metric	4 - 20	39
NH	40° 42°	4			FIREX®	3078	3078	Inch	3/16 - 3/4	39
NH	40° 42°	4			FIREX®	—	3366	Metric	6 - 20	39

Type	Helix angle	Number of teeth	Length	Tool description	Tool material Surface finish	Gurthing no. HA	Gurthing no. HB	Unit	Diameter Range	Page
RF 100 VA - high-performance end mills center cutting					carbide					
N	36° 38°	4			nano-A	4257	4257	Inch	1/8 - 1	41
N	36° 38°	4			nano-A	3804	3805	Metric	4 - 20	43
N	36° 38°	4			nano-A	6700	6701	Metric	6 - 25	43
N	36° 38°	4			nano-A	3080	3080	Inch	1/8 - 1	41
N	36° 38°	4			nano-Si®	3053	3053	Inch	1/8 - 1	42
N	36° 38°	4			nano-A	3800	3803	Metric	3 - 25	43
N	36° 38°	4			nano-A	3806	3807	Metric	6 - 20	43
N	36° 38°	4			nano-A	4258	4258	Inch	3/16 - 1	41
N	36° 38°	4			nano-A	4260	4260	Inch	3/16 - 1	41
N	36° 38°	4			nano-A	4259	4259	Inch	1/4 - 1	41
RF 100 VA - high-performance ball nose end mills center cutting					carbide					
N	36° 38°	4			nano-A	6707	6708	Metric	4.00 - 25.00	45
N	36° 38°	4			nano-A	4261	4261	Inch	1/8 - 1	45

Type	Helix angle	Number of teeth	Length	Tool description	Tool material Surface finish	Gurthing no.	Gurthing no.	Unit	Diameter	Page
						HA	HB			
RF 100 VA/NF - high-performance roughing end mills center cutting					carbide					
NF	36° 38°	4			nano-A	3696	3718	Metric	5 - 25	48
NF	36° 38°	4			nano-A	3081	3081	Inch	1/4 - 1	47
NF	36° 38°	4			nano-Si®	3060	3060	Inch	1/4 - 1	49
NF	36° 38°	4			nano-A	3733	3885	Metric	6 - 20	48
NF	36° 38°	4			nano-A	4262	4262	Inch	1/4 - 1	47
RF 100 A - high-performance end mills center cutting					carbide					
W	40° 42°	4			Bright	3202	3319	Metric	4 - 20	53
W	40° 42°	4			Bright	3077	3077	Inch	3/16 - 3/4	53
RF 100 A - high-performance end mills center cutting					carbide					
W	39° 40° 41°	3			Bright	3472	6702	Metric	3 - 20	55
W	39° 40° 41°	3			Bright	4265	4265	Inch	1/8 - 1	54
W	39° 40° 41°	3			Bright	3473	6703	Metric	6 - 20	55
RF 100 A/WF - high-performance roughing end mills center cutting					carbide					
WF	29° 30° 31°	3			Bright	3468	3469	Metric	6 - 25	51
WF	29° 30° 31°	3			Bright	4266	4266	Inch	1/4 - 1	51
WF	29° 30° 31°	3			Bright	3470	3471	Metric	6 - 20	51

Type	Helix angle	Number of teeth	Length	Tool description	Tool material Surface finish	Gurthing no.	Gurthing no.	Unit	Diameter	Page
						HA	HB			
RF 100 H - high-performance end mills center cutting					carbide					
H	40° 42°	4			FIREX®	3895	3896	Metric	6 - 20	65
RF 100 Ti - high-performance end mills center cutting					carbide					
N	35° 38°	4			Super-A	3498	3499	Metric	6 - 25	58
N	35° 38°	4			Super-A	3876	3876	Inch	1/4 - 1	57
RF 100 SF - high-performance end mills center cutting					carbide					
NH	45°	5			FIREX®	6709	6710	Metric	4 - 25	62
NH	45°	5			FIREX®	4263	4263	Inch	3/16 - 1 1/4	61
NH	45°	5			FIREX®	4264	4264	Inch	3/16 - 1 1/4	61
NH	45°	5			FIREX®	3897	3898	Metric	4 - 20	62
RF 100 SF - high-performance end mills center cutting					carbide					
NH	44° 45° 46°	6			FIREX®	3115	—	Inch	5/16 - 1	63
NH	44° 45° 46°	6			FIREX®	3631	3632	Metric	8 - 25	63

RF 100 U - high-performance end mills for materials up to 1600 N/mm² (48 HRC)

RF 100 U high-performance end mills excel thanks to variable helix angles which considerably reduce vibration. The uneven helix angle vastly improves surface quality with finishing operations and considerably higher feed rates with slot drilling and roughing operations are also achieved.

With many applications, the complete milling process can be covered with one RF 100, which as well as increasing tool life and dimensional accuracy of the workpiece, generates a considerable cost advantage.

Summary of advantages

- suitable for roughing and finishing
- up to 60% higher feed rates
- up to 4-times longer tool life
- vibration-free operation
- improved workpiece surface quality

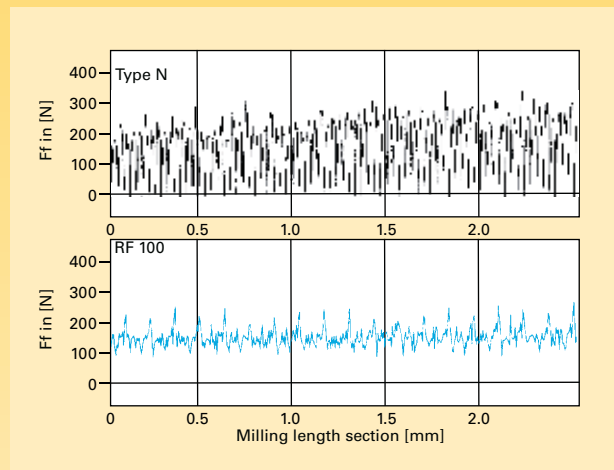
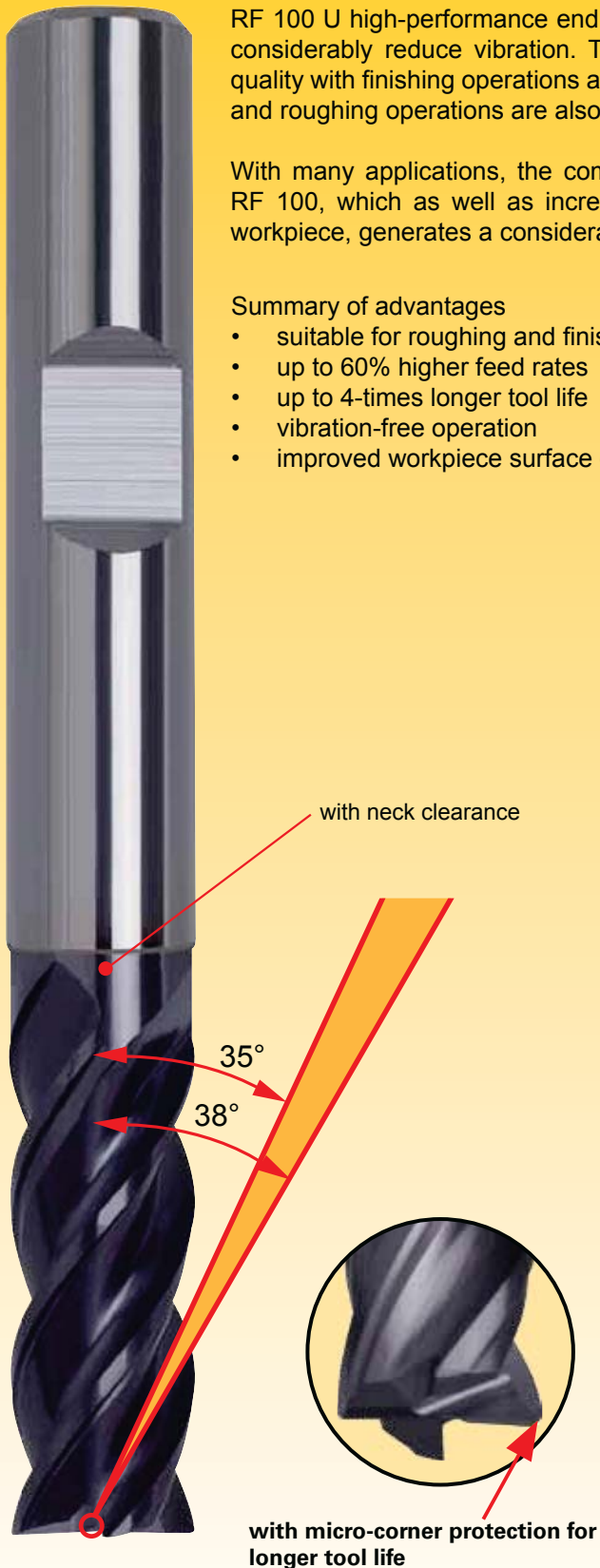

The cutting force comparison between a conventional milling cutter type N and a RF100 clearly shows the quieter, more rigid operation of the RF100.

Material	Alloyed Steel		Tool Steel		Cast iron		Stainless steel		Aluminium		Ti-special alloys		H	
	up to 28HRC	over 28HRC	up to 180 HB 30	over 180 HB 30	up to 28HRC	over 28HRC	up to 3% Si	over 3% Si	Ti-based	Ni-based	up to 52 HRC	above 52 HRC		
RF 100 U	○	●	●	●						●		○		
RF 100 U/HF	○	●	●	●						○		○		
RF 100 F	●	○	○		○	●		○	○	●				
RF 100 VA	●	○	○	○	●	●		○	●	○				
RF 100 VA/NF	●	○	○	○	●	●			●	○				
RF 100 A							●	●						
RF 100 A/WF							●	●						
RF 100 Ti	○	●	○	○					●	○	○			
RF 100 H		○		○								●	●	
RF 100 SF	●	●	●	●	●	●	○	○	●	●	○			

● = optimal suitability

○ = limited suitability

RF 100 U 4-Flute

Variable helix, FIREX® coated

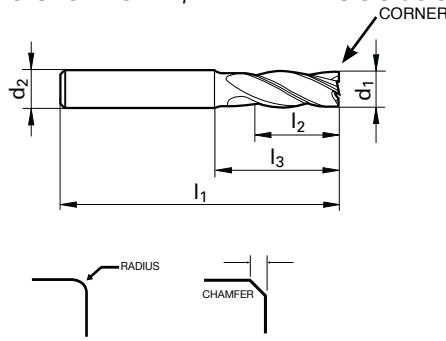

Includes Series	
INCH	
	3079
	3099
	3100
	3113
	3114
	4250
	4251
	4252
	4253

TYPE	N
HELIX ANGLE	35° 38°
NUMBER of TEETH	4

d_1 tolerance h10
 d_2 tolerance h6
 See table on page 150

Diameter	Shank Diameter	OAL	LOC	Reach	Corner		HA		HB	
					Radius Inch	Chamfer Inch	EDP No.	Series Number	EDP No.	Series Number
1/8	1/8	2	3/8			0.002	9031140031700	3114		
3/16	3/16	2	3/8			0.004	9031130047600	3113		
3/16	3/16	2	5/8			0.004	9031140047600	3114		
3/16	3/16	2 1/2	5/8	1		0.004	9042510047600	4251		
3/16	3/16	2 1/2	3/4			0.004	9042500047600	4250		
1/4	1/4	2	1/2			0.006	9031130063500	3113		
1/4	1/4	2 1/2	3/4			0.015	9030790063520	3079		
1/4	1/4	2 1/2	3/4			0.031	9030790063540	3079		
1/4	1/4	2 1/2	3/4			0.006	9031140063500	3114		
1/4	1/4	3 1/4	3/4	1 3/4		0.006	9042510063500	4251		
1/4	1/4	3 1/4	1 1/4			0.006	9042500063500	4250		
1/4	1/4	4	1 3/4			0.006	9042520063500	4252		
5/16	5/16	2	1/2			0.006	9031130079400	3113		
5/16	5/16	2 1/2	13/16			0.031	9030790079440	3079		
5/16	5/16	2 1/2	13/16			0.006	9031140079400	3114		
5/16	5/16	3 1/4	13/16	1 3/4		0.006	9042510079400	4251		
5/16	5/16	3 1/4	1 1/2			0.006	9042500079400	4250		
5/16	5/16	4	1 3/4			0.006	9042520079400	4252		
3/8	3/8	2	5/8			0.008	9031130095200	3113	9030990095200	3099
3/8	3/8	2 1/2	1			0.031	9030790095240	3079		
3/8	3/8	2 1/2	1			0.008	9031140095200	3114	9031000095200	3100
3/8	3/8	4	1	2 1/4		0.008	9042510095200	4251		
3/8	3/8	4	1 3/4			0.008	9042500095200	4250		
3/8	3/8	4	2 1/4			0.008	9042520095200	4252		
7/16	7/16	2 3/4	1			0.031	9030790111140	3079		
7/16	7/16	2 3/4	1			0.008	9031140111100	3114		
7/16	7/16	4 1/2	1	2 1/2		0.008	9042510111100	4251		
7/16	7/16	4 1/2	2			0.008	9042500111100	4250		
7/16	7/16	5	3			0.008	9042520111100	4252		
1/2	1/2	2 1/2	5/8			0.010	9031130127000	3113	9030990127000	3099
1/2	1/2	3	1			0.010	9031140127000	3114	9031000127000	3100
1/2	1/2	3 1/2	1 1/4			0.031			9030790127040	3079
1/2	1/2	3 1/2	1 1/4			0.040			9030790127050	3079
1/2	1/2	3 1/2	1 1/4			0.062			9030790127060	3079
1/2	1/2	3 1/2	1 1/4			0.090			9030790127070	3079

* Indicates reduced neck style

RF 100 U 4-Flute

Variable helix, FIREX® coated

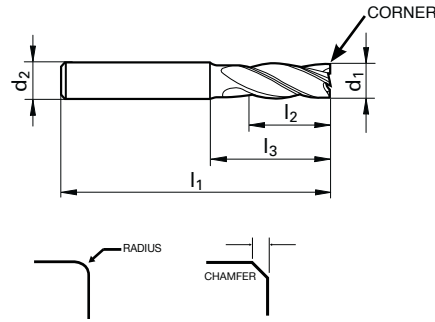

(Continued from previous page)

Diameter	Shank Diameter	OAL	LOC	Reach	Corner		HA		HB	
					Radius Inch	Chamfer Inch	EDP No.	Series Number	EDP No.	Series Number
(d1) Frac	(d2) Frac	(l1) Frac	(l2) Frac	*(l3) Frac						
1/2	1/2	4 1/2	1 1/4	2 1/2		0.010			9042510127000	4251
1/2	1/2	4 1/2	2			0.010			9042500127000	4250
1/2	1/2	5	3			0.010			9042520127000	4252
1/2	1/2	6	3 1/2			0.010			9042530127000	4253
5/8	5/8	3	3/4			0.014	9031130158700		9030990158700	3099
5/8	5/8	3 1/2	1 1/4			0.031			9030790158740	3079
5/8	5/8	3 1/2	1 1/4			0.062			9030790158760	3079
5/8	5/8	3 1/2	1 1/4				9031140158700	3114	9031000158700	3100
5/8	5/8	5	1 1/4	2 1/2		0.014			9042510158700	4251
5/8	5/8	5	2 1/4			0.014			9042500158700	4250
5/8	5/8	6	3			0.014			9042520158700	4252
5/8	5/8	6	3 3/4			0.014			9042530158700	4253
3/4	3/4	3	1			0.018	9031130190500	3113	9030990190500	3099
3/4	3/4	4	1 1/2			0.062			9030790190560	3079
3/4	3/4	4	1 1/2			0.090			9030790190570	3079
3/4	3/4	4	1 1/2			0.125			9030790190590	3079
3/4	3/4	4	1 1/2			0.018	9031140190500	3114	9031000190500	3100
3/4	3/4	5	1 1/2	2 1/2		0.018			9042510190500	4251
3/4	3/4	5	2 1/4			0.018			9042500190500	4250
3/4	3/4	6	3 1/8			0.018			9042520190500	4252
3/4	3/4	6 1/2	4			0.018			9042530190500	4253
1	1	3	1			0.031	9031130254000	3113	9030990254000	3099
1	1	4	1 1/2			0.062			9030790254060	3079
1	1	4	1 1/2			0.090			9030790254070	3079
1	1	4	1 1/2			0.125			9030790254090	3079
1	1	4	1 1/2			0.031	9031140254000	3114	9031000254000	3100
1	1	5	1 1/2	2 5/8		0.031			9042510254000	4251
1	1	5	2 1/4			0.031			9042500254000	4250
1	1	6	3 1/8			0.031			9042520254000	4252
1	1	7	4			0.031			9042530254000	4253
1 1/4	1 1/4	6	2 1/2			0.031	9031140317500	3114		
1 1/4	1 1/4	7 1/2	4			0.031			9042520317500	4252

* Indicates reduced neck style

RF 100 U 4-Flute

Variable helix, FIREX® coated

TYPE **N**

HELIX ANGLE **35°**
38°

NUMBER of TEETH **4**

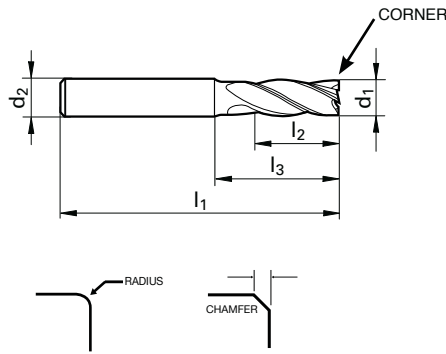

Includes Series	
METRIC	
3627	
3731	
3732	
3736	
3837	
3838	
3839	
3871	
3872	
3873	
6706	

d₁ tolerance h10
d₂ tolerance h6
See table on page 150

Diameter	Shank Diameter	OAL	LOC	Reach	Corner		HA		HB	
					Radius mm	Chamfer mm	EDP No.	Series Number	EDP No.	Series Number
4.0	6.0	57	11	18		0.10	9037360040000	3736	9037320040000	3732
5.0	6.0	57	13	18		0.10	9037360050000	3736	9037320050000	3732
6.0	6.0	54	10	18		0.15	9067060060000	6706	9037310060000	3731
6.0	6.0	57	13	21		0.15	9037360060000	3736	9037320060000	3732
6.0	6.0	57	13	21	0.5		9038720060050	3872	9038730060050	3873
6.0	6.0	57	13	21	1.0		9038720060100	3872	9038730060100	3873
6.0	6.0	57	13	21	2.0		9038720060200	3872	9038730060200	3873
6.0	6.0	65	13	29		0.15	9038370060000	3837	9038380060000	3838
6.0	6.0	65	18	29		0.15	9038390060000	3839	9038710060000	3871
8.0	8.0	58	12	22		0.15	9067060080000	6706	9037310080000	3731
8.0	8.0	63	19	27		0.15	9037360080000	3736	9037320080000	3732
8.0	8.0	63	19	27	0.5		9038720080050	3872	9038730080050	3873
8.0	8.0	63	19	27	1.0		9038720080100	3872	9038730080100	3873
8.0	8.0	63	19	27	2.0		9038720080200	3872	9038730080200	3873
8.0	8.0	75	19	39		0.15	9038370080000	3837	9038380080000	3838
8.0	8.0	75	24	39		0.15	9038390080000	3839	9038710080000	3871
10.0	10.0	66	14	26		0.20	9067060100000	6706	9037310100000	3731
10.0	10.0	72	22	32		0.20	9037360100000	3736	9037320100000	3732
10.0	10.0	72	22	32	0.5		9038720100050	3872	9038730100050	3873
10.0	10.0	72	22	32	1.0		9038720100100	3872	9038730100100	3873
10.0	10.0	72	22	32	2.0		9038720100200	3872	9038730100200	3873
10.0	10.0	80	22	40		0.20	9038370100000	3837	9038380100000	3838
10.0	10.0	80	30	40		0.20	9038390100000	3839	9038710100000	3871
10.0	10.0	100	40	50		0.20	9036270100000	3627		
12.0	12.0	73	16	28		0.20	9067060120000	6706	9037310120000	3731
12.0	12.0	83	26	38		0.20	9037360120000	3736	9037320120000	3732
12.0	12.0	83	26	38	0.5		9038720120050	3872	9038730120050	3873
12.0	12.0	83	26	38	1.0		9038720120100	3872	9038730120100	3873
12.0	12.0	83	26	38	2.0		9038720120200	3872	9038730120200	3873
12.0	12.0	93	26	48		0.20	9038370120000	3837	9038380120000	3838
12.0	12.0	93	36	48		0.20	9038390120000	3839	9038710120000	3871
12.0	12.0	150	45	60		0.20	9036270120000	3627		
14.0	14.0	75	18	30		0.25	9067060140000	6706	9037310140000	3731

* Indicates reduced neck style

RF 100 U 4-Flute

Variable helix, FIREX® coated

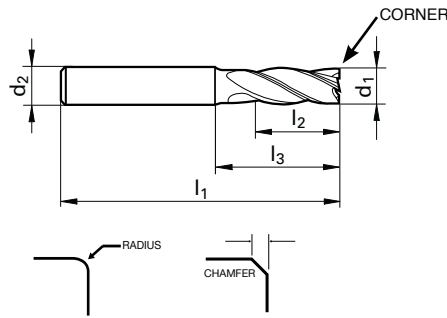

(Continued from previous page)

Diameter	Shank Diameter	OAL	LOC	Reach	Corner		HA		HB	
					Radius mm	Chamfer mm	EDP No.	Series Number	EDP No.	Series Number
(d1) mm	(d2) mm	(l1) mm	(l2) mm	*(l3) mm						
14.0	14.0	83	26	38		0.25	9037360140000	3736	9037320140000	3732
14.0	14.0	150	45	60		0.25	9036270140000	3627		
16.0	16.0	82	22	34		0.35	9067060160000	6706	9037310160000	3731
16.0	16.0	92	32	44		0.35	9037360160000	3736	9037320160000	3732
16.0	16.0	92	32	44	0.5		9038720160050	3872	9038730160050	3873
16.0	16.0	92	32	44	1.0		9038720160100	3872	9038730160100	3873
16.0	16.0	92	32	44	2.0		9038720160200	3872	9038730160200	3873
16.0	16.0	92	32	44	3.0		9038720160300	3872	9038730160300	3873
16.0	16.0	108	32	60		0.35	9038370160000	3837	9038380160000	3838
16.0	16.0	108	48	60		0.35	9038390160000	3839	9038710160000	3871
16.0	16.0	150	65	80		0.35	9036270160000	3627		
18.0	18.0	84	24	36		0.40	9067060180000	6706	9037310180000	3731
18.0	18.0	92	32	44		0.40	9037360180000	3736	9037320180000	3732
18.0	18.0	150	65	80		0.40	9036270180000	3627		
20.0	20.0	92	26	42		0.45	9067060200000	6706	9037310200000	3731
20.0	20.0	104	38	54		0.45	9037360200000	3736	9037320200000	3732
20.0	20.0	104	38	54	0.5		9038720200050	3872	9038730200050	3873
20.0	20.0	104	38	54	1.0		9038720200100	3872	9038730200100	3873
20.0	20.0	104	38	54	2.0		9038720200200	3872	9038730200200	3873
20.0	20.0	104	38	54	3.0		9038720200300	3872	9038730200300	3873
20.0	20.0	126	38	76		0.45	9038370200000	3837	9038380200000	3838
20.0	20.0	126	60	76		0.45	9038390200000	3839	9038710200000	3871
20.0	20.0	150	65	80		0.45	9036270200000	3627		
25.0	25.0	121	45	65		0.60	9037360250000	3736	9037320250000	3732
25.0	25.0	121	45	65	2.0		9038720250200	3872	9038730250200	3873
25.0	25.0	121	45	65	3.0		9038720250300	3872	9038730250300	3873
25.0	25.0	150	75	94		0.60	9036270250000	3627		

* Indicates reduced neck style

With so many tools in Guhring's offering, how do you find the right one for your application?

Guhring has developed a number of ways to help you identify the best Guhring drill, end mill or tap for your application quickly and easily:

First, you can log onto the new www.guhring.com to find a number of helpful resources. Here you'll find a link to Guhring Navigator tool finder software. Navigator allows you to provide basic information about an application and instantly receive a Guhring tooling solution. Just provide the type of material to be machined and the style of tool needed and Navigator will provide the proper Guhring tool as well as the correct operating parameters.

NEW for 2013: Thread Mill Program Generator

Guhring understands that several manufacturers new to thread milling may need help programming their CNC machines properly. Guhring has provided these users with a thread mill CNC program generator to aid in programming their machine for thread mill usage. You can either use the online version or download an installer for a computer that has no internet access. Both options will allow someone to choose tool specifications available for Guhring thread mills and have the option to export the code to a text file.

All Guhring product literature is also available on our website as PDF files for you to view or download, so you are able to page through our most recent catalogs at any time. Each of our main line catalogs begins with a helpful illustrated index to guide you toward the best Guhring drill, end mill or tap for your application, as well as a complete technical section with running parameters.

Our Technical Support staff stands ready to assist you, whether you elect to make a phone call to (800) 776-6170, or to complete the brief online form found at guhring.com under the Technical tab. Expert answers to your tooling or application questions are just a call or a few clicks away!

RF 100 U - high-performance 3-flute end mills for materials up to 44 HRC



RF 100 U end mills excel thanks to unequal helix angles which considerably reduce vibration. The uneven helix angle vastly improves surface quality for finishing operations and a considerably higher feed rate for slot milling operations are also achieved. The three flute design provides additional flute space for improved chip evacuation in slot milling operations or in materials which may clog a standard four flute design.

With many applications, the complete milling process can be covered with one RF 100 U, which as well as increasing tool life and dimensional accuracy of the workpiece generates a considerable cost advantage.

Summary of advantages

- suitable for roughing and finishing
- up to 60% higher feed rates
- up to 4-times longer tool life
- vibration-free operation
- improved workpiece surface quality

FRACTIONAL

RF 100 U 3-Flute

Variable helix, FIREX[®] coated

Includes Series

INCH

4254

4255

TYPE	N
HELIX ANGLE	41° 43° 45°
NUMBER of TEETH	3

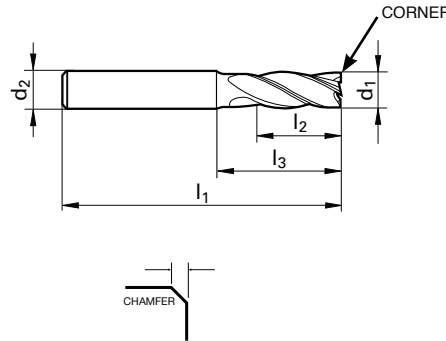

d₁ tolerance h10
d₂ tolerance h6
See table on page 150

Diameter	Shank Diameter	OAL	LOC	Reach	Corner	HA		HB	
(d1) Frac	(d2) Frac	(l1) Frac	(l2) Frac	*(l3) Frac	Chamfer Inch	EDP No.	Series Number	EDP No.	Series Number
1/8	1/8	2	1/4	3/4	0.002	9042550031700	4255		
1/8	1/8	2	1/2		0.002	9042540031700	4254		
3/16	3/16	2	3/8	3/4	0.002	9042550047600	4255		
3/16	3/16	2	5/8		0.002	9042540047600	4254		
1/4	1/4	2 1/2	1/2	7/8	0.004	9042550063500	4255		
1/4	1/4	2 1/2	3/4		0.004	9042540063500	4254		
5/16	5/16	2 1/2	1/2	7/8	0.004	9042550079400	4255		
5/16	5/16	2 1/2	13/16		0.004	9042540079400	4254		
3/8	3/8	2 1/2	5/8	7/8	0.004	9042550095200	4255		
3/8	3/8	2 1/2	1		0.004	9042540095200	4254		
7/16	7/16	2 3/4	1		0.006	9042540111100	4254		
1/2	1/2	3	5/8	1 1/8	0.006			9042550127000	4255
1/2	1/2	3 1/2	1 1/4		0.006			9042540127000	4254
5/8	5/8	3 1/2	3/4	1 1/2	0.006			9042550158700	4255
5/8	5/8	3 1/2	1 1/4		0.006			9042540158700	4254
3/4	3/4	4	1	1 3/4	0.006			9042550190500	4255
3/4	3/4	4	1 1/2		0.006			9042540190500	4254
1	1	4	1	1 3/4	0.008			9042550254000	4255
1	1	4	1 1/2		0.008			9042540254000	4254

RF 100 U 3-Flute

Variable helix, FIREX® coated

Includes Series

METRIC
3891
3892
3893
3894



TYPE	N
HELIX ANGLE	41° 43° 45°
NUMBER of TEETH	3

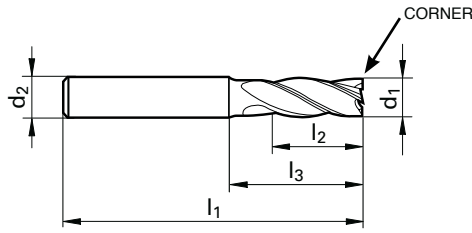

d₁ tolerance h10
d₂ tolerance h6
See table on page 150

Diameter	Shank Diameter	OAL	LOC	Reach	Corner	HA		HB	
						EDP No.	Series Number	EDP No.	Series Number
3.0	6.0	57	4	15	0.05	9038930030000	3893	9038940030000	3894
3.0	6.0	57	8	15	0.05	9038910030000	3891	9038920030000	3892
3.5	6.0	57	10	15	0.05	9038910035000	3891	9038920035000	3892
3.7	6.0	57	11	15	0.05	9038910037000	3891	9038920037000	3892
4.0	6.0	57	5	18	0.05	9038930040000	3893	9038940040000	3894
4.0	6.0	57	11	18	0.05	9038910040000	3891	9038920040000	3892
4.5	6.0	57	11	18	0.05	9038910045000	3891	9038920045000	3892
4.7	6.0	57	13	18	0.05	9038910047000	3891	9038920047000	3892
5.0	6.0	57	6	18	0.05	9038930050000	3893	9038940050000	3894
5.0	6.0	57	13	18	0.05	9038910050000	3891	9038920050000	3892
5.5	6.0	57	13	18	0.05	9038910055000	3891	9038920055000	3892
5.7	6.0	57	13	18	0.05	9038910057000	3891	9038920057000	3892
6.0	6.0	57	7	21	0.05	9038930060000	3893	9038940060000	3894
6.0	6.0	57	13	21	0.05	9038910060000	3891	9038920060000	3892
6.5	8.0	63	16	27	0.10	9038910065000	3891	9038920065000	3892
7.0	8.0	63	16	27	0.10	9038910070000	3891	9038920070000	3892
7.5	8.0	63	19	27	0.10	9038910075000	3891	9038920075000	3892
8.0	8.0	63	9	27	0.10	9038930080000	3893	9038940080000	3894
8.0	8.0	63	19	27	0.10	9038910080000	3891	9038920080000	3892
8.5	10.0	72	19	32	0.10	9038910085000	3891	9038920085000	3892
9.0	10.0	72	19	32	0.10	9038910090000	3891	9038920090000	3892
9.5	10.0	72	22	32	0.10	9038910095000	3891	9038920095000	3892
10.0	10.0	72	11	32	0.10	9038930100000	3893	9038940100000	3894
10.0	10.0	72	22	32	0.10	9038910100000	3891	9038920100000	3892
12.0	12.0	83	12	38	0.15	9038930120000	3893	9038940120000	3894
12.0	12.0	83	26	38	0.15	9038910120000	3891	9038920120000	3892
16.0	16.0	92	16	44	0.15	9038930160000	3893	9038940160000	3894
16.0	16.0	92	32	44	0.15	9038910160000	3891	9038920160000	3892
20.0	20.0	104	38	54	0.15	9038910200000	3891	9038920200000	3892



* Indicates reduced neck style

RF 100 U/HF - high-performance roughing end mills for materials up to 1600 N/mm² (48 HRC)

Based on our RF 100 end mill with variable helix angles in combination with a newly developed roughing geometry. The result is a dramatic increase in tool life in comparison to conventional rough milling cutters with round or flat knuckle-type teeth. At the same time, the surface quality of the workpiece is improved to a peak-to-valley height of appr. Ra = 2-3 µm, making in many cases finishing operations unnecessary.

Simultaneously, the innovative design reduces power consumption in comparison to conventional RF 100 end mills allowing the application in unstable conditions and on less powerful machines.

- Summary of advantages
- low cutting pressure and power consumption
 - vibration-free operation
 - increased feed rates possible
 - increased surface qualities ($R_a = 2-3 \mu\text{m}$)
 - longer tool life

Type	RF 100 U smooth cutting	RF 100 U/HF 
Performance index	100%	70%
Workpiece surface	$R_a = 1-2 \mu\text{m}$ 	$R_a = 2-3 \mu\text{m}$ 
Tool life index	100%	75%
Power consumption	160%	100%
Cutting pressure	150%	100%

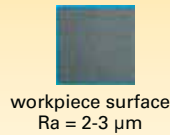
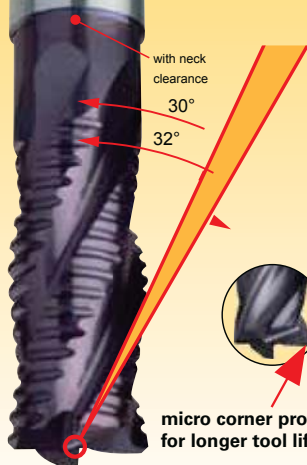

FRACTIONAL

RF 100 U/HF 4-Flute

Variable helix, Rougher, FIREX® coated

Includes Series
INCH
3082
4256

TYPE	HF
HELIX ANGLE	30° 32°
NUMBER of TEETH	4

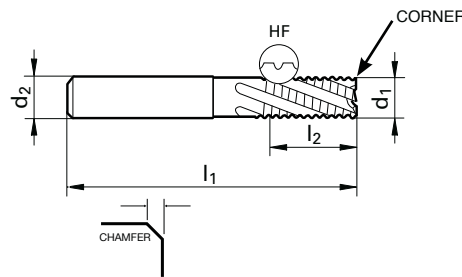

d_1 tolerance h10
 d_2 tolerance h6
See table on page 150

Diameter	Shank Diameter	OAL	LOC	Corner	HA		HB	
(d1) Frac	(d2) Frac	(l1) Frac	(l2) Frac	Chamfer Inch	EDP No.	Series Number	EDP No.	Series Number
1/4	1/4	2 1/2	3/4	0.012	9030820063500	3082		
1/4	1/4	3 1/4	1 1/4	0.012	9042560063500	4256		
5/16	5/16	2 1/2	13/16	0.012	9030820079400	3082		
5/16	5/16	3 1/4	1 1/2	0.012	9042560079400	4256		
3/8	3/8	2 1/2	1	0.012	9030820095200	3082		
3/8	3/8	4	1 3/4	0.012	9042560095200	4256		
1/2	1/2	3 1/2	1 1/4	0.020			9030820127000	3082
1/2	1/2	4 1/2	2	0.020			9042560127000	4256
5/8	5/8	3 1/2	1 1/4	0.020			9030820158700	3082
5/8	5/8	5	2 1/4	0.020			9042560158700	4256
3/4	3/4	4	1 1/2	0.020			9030820190500	3082
3/4	3/4	5	2 1/4	0.020			9042560190500	4256
1	1	4	1 1/2	0.031			9030820254000	3082
1	1	5	2 1/4	0.031			9042560254000	4256

RF 100 U/HF 4-flute

Variable helix, Rougher, FIREX® coated

Includes Series

METRIC
3507
3508
3509
3522
3598
3600



TYPE	HF
HELIX ANGLE	30° 32°
NUMBER of TEETH	4

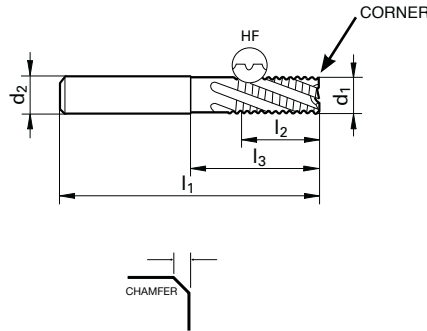

d₁ tolerance h10
d₂ tolerance h6
See table on page 150

Diameter	Shank Diameter	OAL	LOC	Reach	Corner	HA		HB	
(d1) mm	(d2) mm	(l1) mm	(l2) mm	*(l3) mm	Chamfer mm	EDP No.	Series Number	EDP No.	Series Number
6.0	6.0	57	13	21	0.30	9035070060000	3507	9035080060000	3508
6.0	6.0	65	18	29	0.30	9035090060000	3509	9035220060000	3522
6.0	6.0	75	13	35	0.30	9035980100000	3598	9036000060000	3600
8.0	8.0	63	19	27	0.30	9035070080000	3507	9035080080000	3508
8.0	8.0	75	24	39	0.30	9035090080000	3509	9035220080000	3522
8.0	8.0	100	19	50	0.30	9035980120000	3598	9036000080000	3600
10.0	10.0	72	22	32	0.30	9035070100000	3507	9035080100000	3508
10.0	10.0	80	30	40	0.30	9035090100000	3509	9035220100000	3522
10.0	10.0	100	22	50	0.30	9035980140000	3598	9036000100000	3600
12.0	12.0	83	26	38	0.50	9035070120000	3507	9035080120000	3508
12.0	12.0	93	36	48	0.50	9035090120000	3509	9035220120000	3522
12.0	12.0	150	26	60	0.50	9035980160000	3598	9036000120000	3600
16.0	16.0	92	32	44	0.50	9035070160000	3507	9035080160000	3508
16.0	16.0	108	48	60	0.50	9035090160000	3509	9035220160000	3522
16.0	16.0	150	32	80	0.50	9035980180000	3598	9036000160000	3600
20.0	20.0	104	38	54	0.50	9035070200000	3507	9035080200000	3508
20.0	20.0	126	60	76	0.50	9035090200000	3509	9035220200000	3522
20.0	20.0	150	38	80	0.50	9035980200000	3598	9036000200000	3600
25.0	25.0	121	45	65	0.80	9035070250000	3507	9035080250000	3508

* Indicates reduced neck style

Guhring RF 50 variable flute end mills for materials < 54 HRC

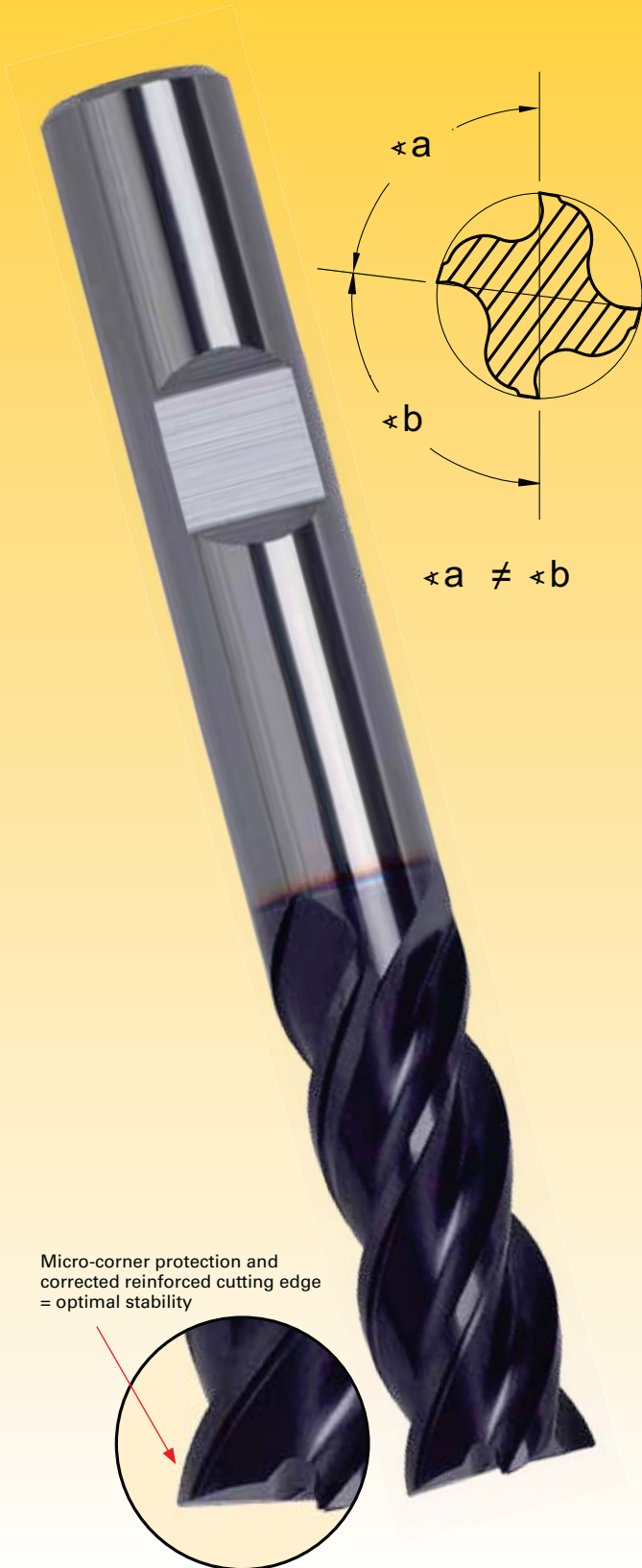

We have developed the RF 50 end mill with variable flute spacing primarily to prevent chatter and the so-called corkscrew effect (as found when withdrawing tools having a large spiral angle)

However, the variable flute spacing does not only combat these two unwanted effects but offers the following additional advantages:

- Higher feed rates
- longer tool life
- increased milling depths
- vibration-free machining
- suitable for roughing and finishing
- increased surface finish quality
- straighter cutting

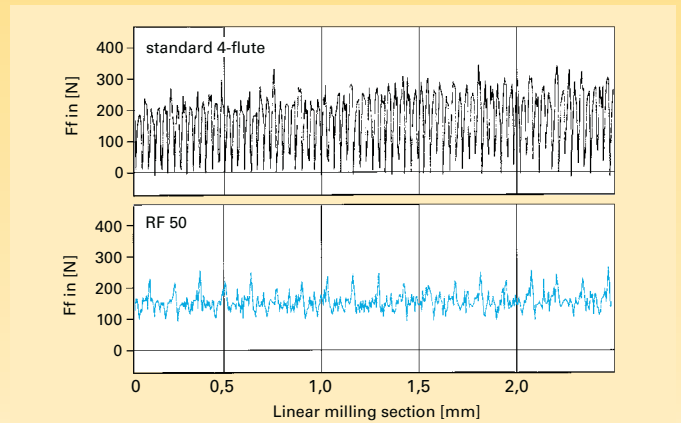

A cutting force comparison between a conventional type N and a RF 50 variable helix end mill clearly shows the RF 50 end mill's quieter and more stable machining characteristics.

Material	Alloyed Steel	Tool Steel	Cast iron	Stainless steel	Aluminium	Ti-special alloys	H
Hardness tensile strength	up to 28HRC	over 28 HRC	up to 180 HB 30 over 180 HB 30	up to 28 HRC over 28 HRC	up to 3% Si over 3% Si	Ti-based Ni-based	up to 52 HRC up to 52 HRC
RF 100 U	○	●	●			●	○

● = optimal suitability ○ = limited suitability

RF 50 4-Flute

Variable flute, FIREX® coated

Includes Series

INCH

3095

3096

TYPE

N

HELIX ANGLE

40°

NUMBER of TEETH

4

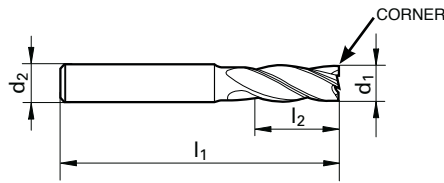

d_1 tolerance h10
 d_2 tolerance h6
 See table on page 150

Diameter	Shank Diameter	OAL	LOC	Corner	HA		HB	
					EDP No.	Series Number	EDP No.	Series Number
3/16	3/16	2	3/8	0.004	9030950047600	3095		
3/16	3/16	2	5/8	0.004	9030960047600	3096		
1/4	1/4	2	1/2	0.006	9030950063500	3095		
1/4	1/4	2 1/2	3/4	0.006	9030960063500	3096		
5/16	5/16	2	1/2	0.006	9030950079400	3095		
5/16	5/16	2 1/2	13/16	0.006	9030960079400	3096		
3/8	3/8	2	5/8	0.008	9030950095200	3095		
3/8	3/8	2 1/2	1	0.008	9030960095200	3096		
7/16	7/16	2 3/4	1	0.008	9030960111100	3096		
1/2	1/2	2 1/2	5/8	0.010			9030950127000	3095
1/2	1/2	3	1	0.010			9030960127000	3096
5/8	5/8	3	3/4	0.014			9030950158700	3095
5/8	5/8	3 1/2	1 1/4	0.014			9030960158700	3096
3/4	3/4	3	1	0.018			9030950190500	3095
3/4	3/4	4	1 1/2	0.018			9030960190500	3096
1	1	3	1	0.030			9030950254000	3095
1	1	4	1 1/2	0.030			9030960254000	3096

RF 100 F - high-performance roughing end mills for materials up to 850 N/mm² (25 HRC)

RF 100 F high-performance end mills excel thanks to variable helix angles which considerably reduce vibration. The uneven helix angle vastly improves surface quality for finishing operations and a considerably higher feed rate for slot drilling and roughing operations are also achieved.

With many applications, the complete milling process can be covered with one RF 100 F. which as well as increasing tool life and dimensional accuracy of the workpiece generates a considerable cost advantage.

Summary of advantages

- suitable for roughing and finishing
- up to 60% higher feed rates
- up to 4-times longer tool life
- vibration-free operation
- improved workpiece surface quality

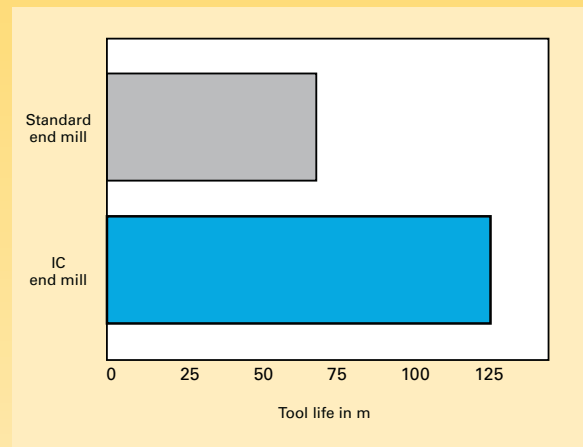
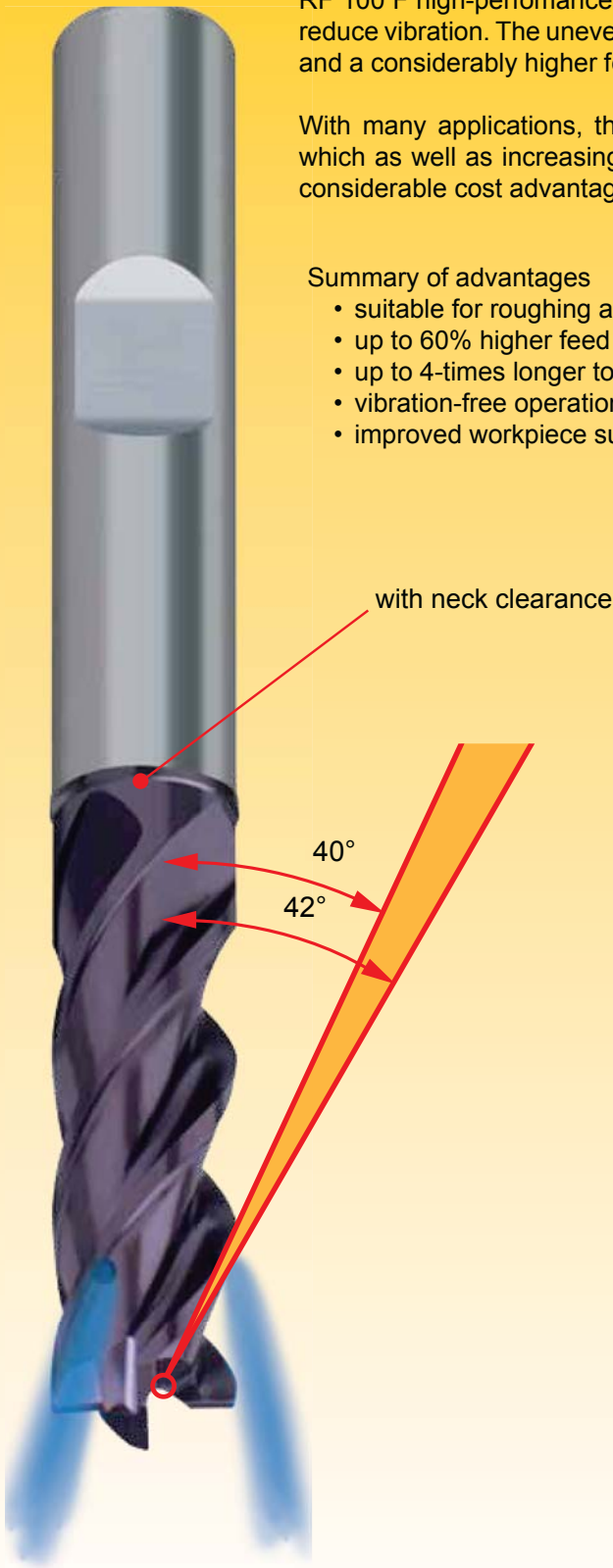

Tool life comparison between end mills with internal cooling and conventional end mills without internal cooling with roughing operations in tool steel.

Material	Alloyed Steel		Tool Steel		Cast iron		Stainless steel		Aluminium		Ti-special alloys		H	
	up to 28Hrc	over 28Hrc	up to 180 HB 30	over 180 HB 30	up to 28Hrc	over 28Hrc	up to 3% Si	over 3% Si	Ti-based	Ni-based	up to 52 HRC	above 52 HRC		
RF 100 U	○	●	●	●						●		○		
RF 100 U/HF	○	●	●	●						○		○		
RF 100 F	●	○	○		○	●		○	○	●				
RF 100 VA	●	○	○	○	●	●		○	●	○				
RF 100 VA/NF	●	○	○	○	●	●			●	○				
RF 100 A									●	●				
RF 100 AWF									●	●				
RF 100 Ti	○	●	○	○						●	○	○		
RF 100 H		○		○									●	●
RF 100 SF	●	●	●	●	●	●	○	○	●	●	○			

● = optimal suitability

○ = limited suitability

RF 100 F 4-flute

Variable helix, FIREX® coated

Includes Series

INCH

3078



TYPE	NH
HELIX ANGLE	40° 42°
NUMBER of TEETH	4

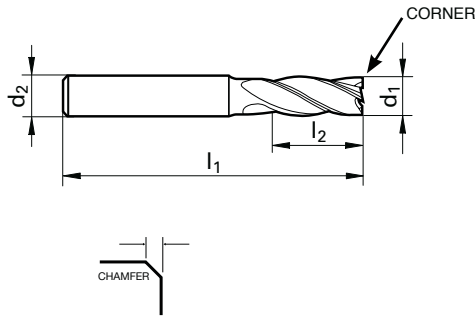

d₁ tolerance h10
d₂ tolerance h6
See table on page 150

Diameter	Shank Diameter	OAL	LOC	Corner	HA		HB	
(d1) Frac	(d2) Frac	(l1) Frac	(l2) Frac	Chamfer Inch	EDP No.	Series Number	EDP No.	Series Number
3/16	3/16	2	5/8	0.004	9030780047600	3078		
1/4	1/4	2 1/2	3/4	0.006	9030780063500	3078		
5/16	5/16	2 1/2	13/16	0.006	9030780079400	3078		
3/8	3/8	2 1/2	1	0.008	9030780095200	3078		
1/2	1/2	3 1/2	1 1/4	0.010			9030780127000	3078
5/8	5/8	3 1/2	1 1/4	0.014			9030780158700	3078
3/4	3/4	4	1 1/2	0.018			9030780190500	3078

METRIC

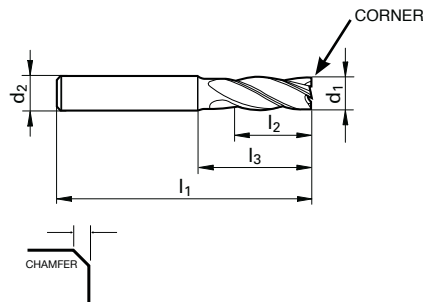

Includes Series

METRIC

*3366

3629

3630

*Coolant through

Diameter	Shank Diameter	OAL	LOC	Reach	Corner	HA		HB		HB	
(d1) mm	(d2) mm	(l1) mm	(l2) mm	*(l3) mm	Chamfer mm	EDP No.	Series Number	EDP No.	Series Number	EDP No.	Series Number
4.0	6.0	57	11	18	0.10	9036290040000	3629	9036300040000	3630		
5.0	6.0	57	13	18	0.10	9036290050000	3629	9036300050000	3630		
6.0	6.0	57	13	21	0.15	9036290060000	3629	9036300060000	3630	9033660060000	3366
8.0	8.0	63	19	27	0.15	9036290080000	3629	9036300080000	3630	9033660080000	3366
10.0	10.0	72	22	32	0.20	9036290100000	3629	9036300100000	3630	9033660100000	3366
12.0	12.0	83	26	38	0.20	9036290120000	3629	9036300120000	3630	9033660120000	3366
16.0	16.0	92	32	44	0.35	9036290160000	3629	9036300160000	3630	9033660160000	3366
20.0	20.0	104	38	54	0.45	9036290200000	3629	9036300200000	3630	9033660200000	3366

* Indicates reduced neck style

RF 100 VA - high-performance roughing end mills for stainless steels

RF 100 U high-performance end mills excel thanks to variable helix angles which considerably reduce vibration. The uneven helix angle vastly improves surface quality with finishing operations and considerably higher feed rates with slot drilling and roughing operations are also achieved.

With many applications, the complete milling process can be covered with one RF 100, which as well as increasing tool life and dimensional accuracy of the workpiece generates a considerable cost advantage.

Summary of advantages

- suitable for roughing and finishing
- up to 60% higher feed rates
- up to 4-times longer tool life
- vibration-free operation
- improved workpiece surface quality

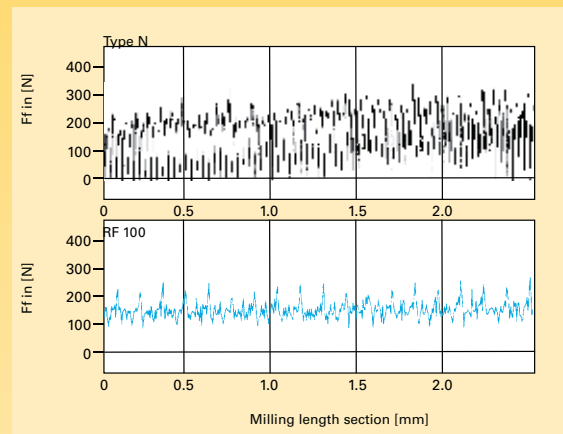
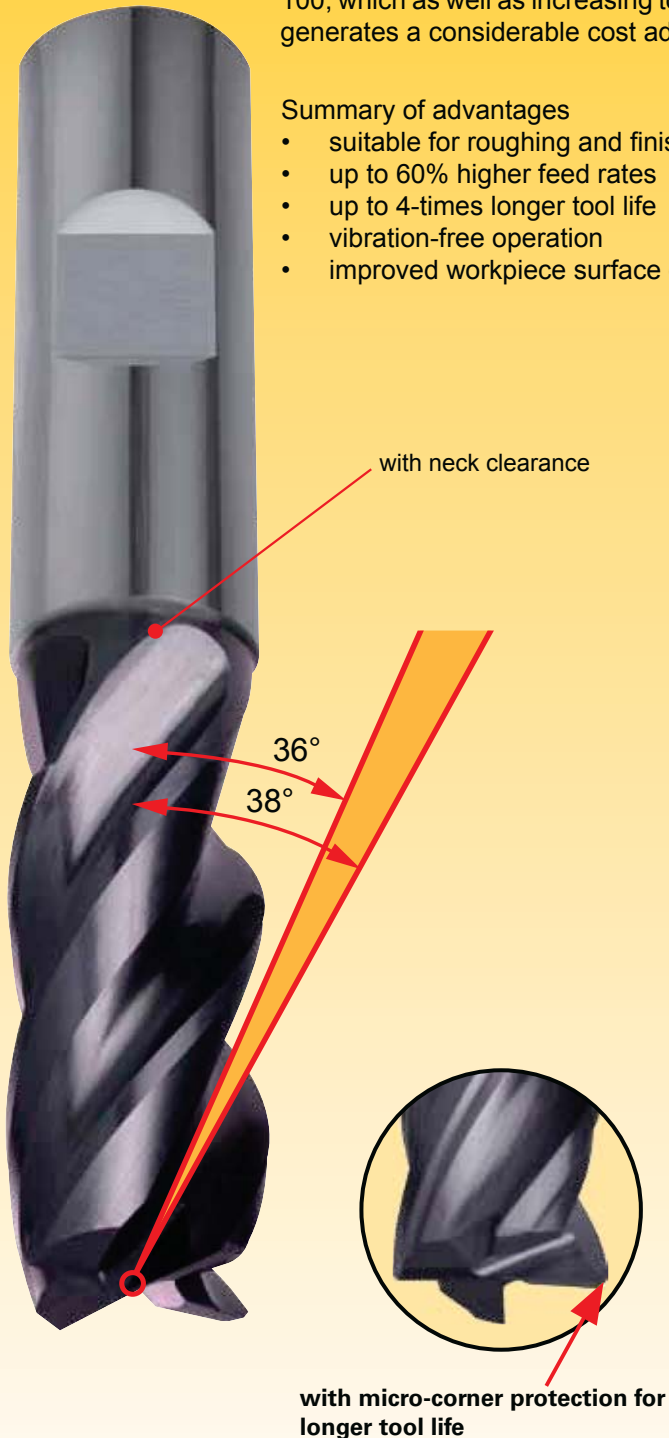

The cutting force comparison between a conventional milling cutter type N and the RF 100 shows a clearly quieter, more rigid operation of the RF 100.

Material	Alloyed Steel		Tool Steel		Cast iron		Stainless steel		Aluminium		Ti-special alloys		H	
	up to 28Hrc	over 28Hrc	up to 180 HB 30	over 180 HB 30	up to 28Hrc	over 28Hrc	up to 3% Si	over 3% Si	Ti-based	Ni-based	up to 52 HRC	above 52 HRC		
RF 100 U	○	●	●	●					●		○			
RF 100 U/HF	○	●	●	●					○		○			
RF 100 F	●	○	○		○	●		○	○	●				
RF 100 VA	●	○	○	○	●	●		○	●	○				
RF 100 VA/NF	●	○	○	○	●	●			●	○				
RF 100 A							●	●						
RF 100 AWF							●	●						
RF 100 Ti	○	●	○	○					●	○	○			
RF 100 H		○		○							●	●		
RF 100 SF	●	●	●	●	●	●	○	○	●	●	○			

● = optimal suitability

○ = limited suitability

RF 100 VA 4-Flute

Variable helix, nano-A coated

Includes Series

INCH
3080
4257
4258
4259
4260



TYPE **VA**

HELIX ANGLE **36°**
38°

NUMBER of TEETH **4**

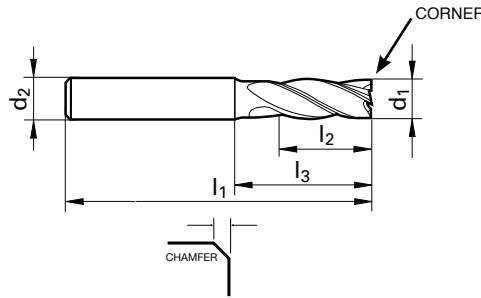

d₁ tolerance h10
d₂ tolerance h6
See table on page 150

Diameter	Shank Diameter	OAL	LOC	Reach	Corner	HA		HB	
						EDP No.	Series Number	EDP No.	Series Number
(d1) Frac	(d2) Frac	(l1) Frac	(l2) Frac	*(l3) Frac	Chamfer Inch				
1/8	1/8	1 1/2	1/4		0.004	9042570031700	4257		
1/8	1/8	1 1/2	3/8		0.004	9030800031700	3080		
3/16	3/16	2	3/8		0.006	9042570047600	4257		
3/16	3/16	2	5/8		0.006	9030800047600	3080		
3/16	3/16	2 1/2	5/8	1	0.006	9042600047600	4260		
3/16	3/16	2 1/2	3/4		0.006	9042580047600	4258		
1/4	1/4	2	1/2		0.010	9042570063500	4257		
1/4	1/4	2 1/2	3/4		0.010	9030800063500	3080		
1/4	1/4	3 1/4	3/4	1 3/4	0.010	9042600063500	4260		
1/4	1/4	3 1/4	1 1/4		0.010	9042580063500	4258		
1/4	1/4	4	1 3/4		0.010	9042590063500	4259		
5/16	5/16	2	1/2		0.010	9042570079400	4257		
5/16	5/16	2 1/2	13/16		0.010	9030800079400	3080		
5/16	5/16	3 1/4	13/16	1 3/4	0.010	9042600079400	4260		
5/16	5/16	3 1/4	1 1/2		0.010	9042580079400	4258		
5/16	5/16	4	1 3/4		0.010	9042590079400	4259		
3/8	3/8	2	5/8		0.012	9042570095200	4257		
3/8	3/8	2 1/2	1		0.012	9030800095200	3080		
3/8	3/8	4	1	2 1/4	0.012	9042600095200	4260		
3/8	3/8	4	1 3/4		0.012	9042580095200	4258		
3/8	3/8	4	2 1/4		0.012	9042590095200	4259		
1/2	1/2	2 1/2	5/8		0.016			9042570127000	4257
1/2	1/2	3 1/2	1 1/4		0.016			9030800127000	3080
1/2	1/2	4 1/2	1 1/4	2 1/2	0.016			9042600127000	4260
1/2	1/2	4 1/2	2		0.016			9042580127000	4258
1/2	1/2	5	3		0.016			9042590127000	4259
5/8	5/8	3	3/4		0.020			9042570158700	4257
5/8	5/8	3 1/2	1 1/4		0.020			9030800158700	3080
5/8	5/8	5	1 1/4	2 1/2	0.020			9042600158700	4260
5/8	5/8	5	2 1/4		0.020			9042580158700	4258
5/8	5/8	6	3		0.020			9042590158700	4259
3/4	3/4	3	1		0.024			9042570190500	4257
3/4	3/4	4	1 1/2		0.024			9030800190500	3080
3/4	3/4	5	1 1/2	2 1/2	0.024			9042600190500	4260
3/4	3/4	5	2 1/4		0.024			9042580190500	4258
3/4	3/4	6	3 1/8		0.024			9042590190500	4259
1	1	3	1		0.035			9042570254000	4257
1	1	4	1 1/2		0.035			9030800254000	3080
1	1	5	1 1/2	2 5/8	0.035			9042600254000	4260
1	1	5	2 1/4		0.035			9042580254000	4258
1	1	6	3 1/8		0.035			9042590254000	4259

* Indicates reduced neck style

RF 100 VA 4-Flute

Variable helix, nano-Si[®] coated

Includes Series
METRIC
3053

TYPE	VA
HELIX ANGLE	36° 38°
NUMBER of TEETH	4

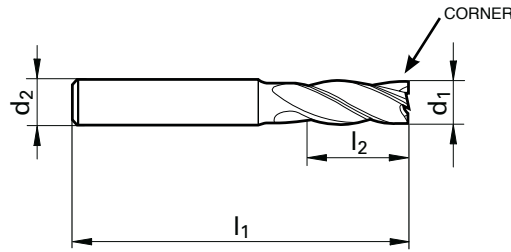

d₁ tolerance h10
d₂ tolerance h6
See table on page 150



Diameter	Shank Diameter	OAL	LOC	Corner		HA	HB	
(d1) mm	(d2) mm	(l1) mm	(l2) mm	Chamfer mm	Flutes	EDP No.	Series Number	
1/8	1/8	1 1/2	3/8	0.004	4	9030530031700	3053	
3/16	3/16	2	5/8	0.006	4	9030530047600	3053	
1/4	1/4	2 1/2	3/4	0.010	4	9030530063500	3053	
5/16	5/16	2 1/2	13/16	0.010	4	9030530079400	3053	
3/8	3/8	2 1/2	1	0.012	4	9030530095200	3053	
1/2	1/2	3 1/2	1 1/4	0.016	4		9030530127000	3053
5/8	5/8	3 1/2	1 1/4	0.020	4		9030530158700	3053
3/4	3/4	4	1 1/2	0.024	4		9030530190500	3053
1	1	4	1 1/2	0.035	4		9030530254000	3053

nano-Si[®] Coating

Ultra Hard and Heat Resistant

- 5,500 Vickers hardness
- 2,192 F oxidation temperature

57% harder than TiAlN coatings

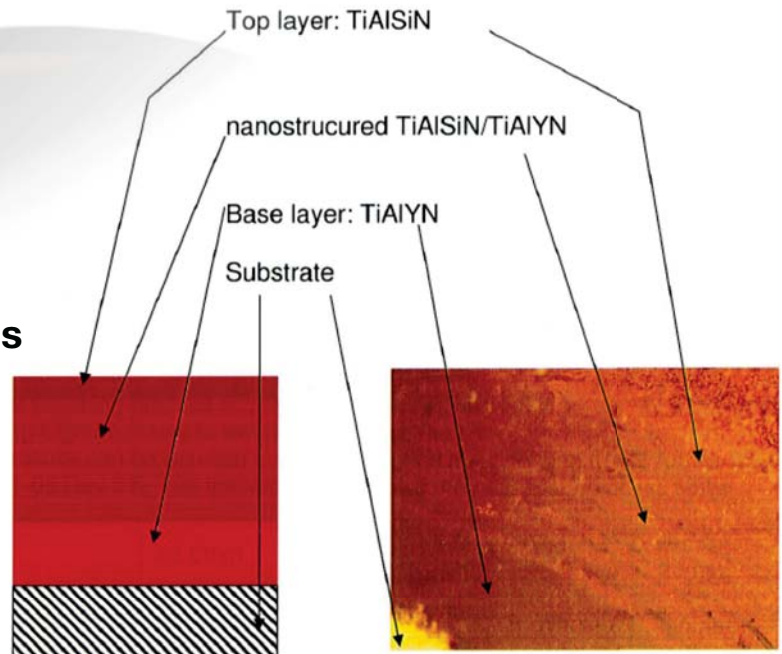

RF 100 VA 4-Flute

Variable helix, nano-A coated

Includes Series

METRIC

3800

3803

3804

3805

3806

3807

*6700

*6701

*Coolant through



TYPE

VA

HELIX ANGLE

36°
38°

NUMBER OF TEETH

4

d₁ tolerance h10
d₂ tolerance h6
See table on page 150

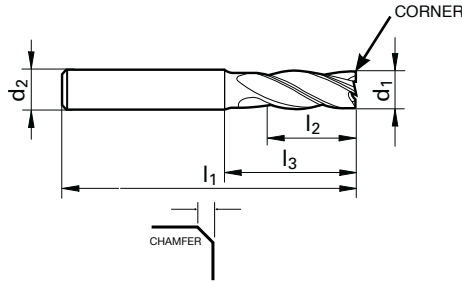

* Indicates reduced neck style

Diameter	Shank Diameter	OAL	LOC	Reach	Corner	HA		HB	
						EDP No.	Series Number	EDP No.	Series Number
3.0	6.0	57	8	15	0.10	9038000030000	3800	9038030030000	3803
3.5	6.0	57	10	15	0.10	9038000035000	3800	9038030035000	3803
4.0	6.0	54	8	15	0.15	9038040040000	3804	9038050040000	3805
4.0	6.0	57	11	18	0.15	9038000040000	3800	9038030040000	3803
4.5	6.0	57	11	18	0.15	9038000045000	3800	9038030045000	3803
5.0	6.0	54	9	15	0.20	9038040050000	3804	9038050050000	3805
5.0	6.0	57	13	18	0.20	9038000050000	3800	9038030050000	3803
5.5	6.0	57	13	18	0.20	9038000055000	3800	9038030055000	3803
6.0	6.0	54	10	18	0.20	9038040060000	3804	9038050060000	3805
6.0	6.0	57	13	21	0.20	9038000060000	3800	9038030060000	3803
6.0	6.0	57	13	21	0.20	9067000060000	6700	9067010060000	6701
6.0	6.0	65	10	29	0.20	9038060060000	3806	9038070060000	3807
6.5	8.0	63	16	27	0.25	9038000065000	3800	9038030065000	3803
7.0	8.0	63	16	27	0.25	9038000070000	3800	9038030070000	3803
7.5	8.0	63	19	27	0.25	9038000075000	3800	9038030075000	3803
8.0	8.0	58	12	22	0.25	9038040080000	3804	9038050080000	3805
8.0	8.0	63	19	27	0.25	9067000080000	6700	9067010080000	6701
8.0	8.0	63	19	27	0.25	9038000080000	3800	9038030080000	3803
8.0	8.0	75	12	39	0.25	9038060080000	3806	9038070080000	3807
8.5	10.0	72	19	32	0.30	9038000085000	3800	9038030085000	3803
9.0	10.0	72	19	32	0.30	9038000090000	3800	9038030090000	3803
9.5	10.0	72	22	32	0.30	9038000095000	3800	9038030095000	3803
10.0	10.0	66	14	26	0.30	9038040100000	3804	9038050100000	3805
10.0	10.0	72	22	32	0.30	9038000100000	3800	9038030100000	3803
10.0	10.0	72	22	32	0.30	9067000100000	6700	9067010100000	6701
10.0	10.0	80	14	40	0.30	9038060100000	3806	9038070100000	3807
11.0	12.0	83	26	38	0.35	9038000110000	3800	9038030110000	3803
12.0	12.0	73	16	28	0.35	9038040120000	3804	9038050120000	3805
12.0	12.0	83	26	38	0.35	9038000120000	3800	9038030120000	3803
12.0	12.0	83	26	38	0.35	9067000120000	6700	9067010120000	6701
12.0	12.0	93	16	48	0.35	9038060120000	3806	9038070120000	3807
14.0	14.0	83	26	38	0.40	9038000140000	3800	9038030140000	3803
16.0	16.0	82	22	34	0.50	9038040160000	3804	9038050160000	3805
16.0	16.0	92	32	44	0.50	9038000160000	3800	9038030160000	3803
16.0	16.0	92	32	44	0.50	9067000160000	6700	9067010160000	6701
16.0	16.0	108	22	60	0.50	9038060160000	3806	9038070160000	3807
18.0	18.0	92	32	44	0.60	9038000180000	3800	9038030180000	3803
20.0	20.0	92	26	42	0.60	9038040200000	3804	9038050200000	3805
20.0	20.0	104	38	54	0.60	9038000200000	3800	9038030200000	3803
20.0	20.0	104	38	54	0.60	9067000200000	6700	9067010200000	6701
20.0	20.0	126	26	76	0.60	9038060200000	3806	9038070200000	3807
25.0	25.0	121	45	65	0.75	9067000250000	6700	9067010250000	6701
25.0	25.0	121	45	65	0.75	9038000250000	3800	9038030250000	3803

RF 100 VA- ball nose end mills

The RF 100 VA ball nose end mill is based on the RF 100 variable helix design for tougher materials but with a full ball nose design for finishing operations. The variable helix design increases tool life dramatically while reducing vibration in the cut. Part finish quality is improved dramatically over standard helix ball nose carbide end mill designs.



Material	Alloyed Steel		Tool Steel		Cast iron		Stainless steel		Aluminium		Ti-special alloys		H	
	up to 28HRC	over 28HRC	up to 180 HB 30	over 180 HB 30	up to 28HRC	over 28HRC	up to 3% Si	over 3% Si	Ti-based	Ni-based	up to 52 HRC	above 52 HRC		
RF 100 U	○	●	●	●					●		○			
RF 100 U/HF	○	●	●	●					○		○			
RF 100 F	●	○	○		○	●		○	○	●				
RF 100 VA	●	○	○	○	●	●		○	●	○				
RF 100 VA/NF	●	○	○	○	●	●			●	○				
RF 100 A							●	●						
RF 100 A/WF							●	●						
RF 100 Ti	○	●	○	○					●	○	○			
RF 100 H		○		○								●	●	
RF 100 SF	●	●	●	●	●	●	○	○	●	●	○			

● = optimal suitability

○ = limited suitability

RF 100 VA 4-Flute

Variable helix, Ball nose, nano-A coated

Includes Series

INCH

4261



TYPE

N

HELIX ANGLE



NUMBER of TEETH



d_1 tolerance h10
 d_2 tolerance h6
 See table on page 150

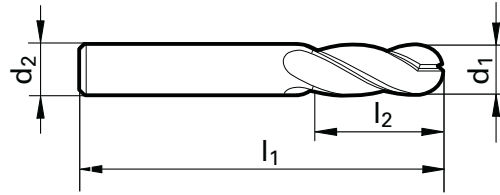

Diameter	Shank Diameter	OAL	LOC	HA		HB	
				EDP No.	Series Number	EDP No.	Series Number
1/8	1/8	2	1/2	9042610031700	4261		
3/16	3/16	2	5/8	9042610047610	4261		
1/4	1/4	2 1/2	3/4	9042610063500	4261		
5/16	5/16	2 1/2	13/16	9042610079400	4261		
3/8	3/8	2 1/2	1	9042610095200	4261		
7/16	7/16	2 3/4	1	9042610111100	4261		
1/2	1/2	3 1/2	1 1/4			9042610127000	4261
5/8	5/8	3 1/2	1 1/4			9042610158700	4261
3/4	3/4	4	1 1/2			9042610190500	4261
1	1	4	1 1/2			9042610254000	4261

METRIC

d_1 tolerance h10
 d_2 tolerance h6
 See table on page 150

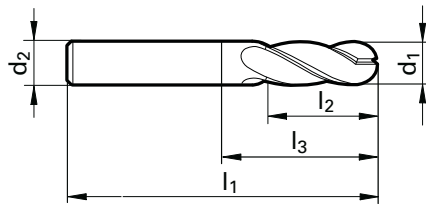

Includes Series

METRIC

6707

6708

Diameter	Shank Diameter	OAL	LOC	Reach	HA		HB	
					EDP No.	Series Number	EDP No.	Series Number
4.0	6.0	57	11	18	9067070040000	6707	9067080040000	6708
5.0	6.0	57	13	18	9067070040000	6707	9067080040000	6708
6.0	6.0	57	13	21	9067070060000	6707	9067080060000	6708
8.0	8.0	63	19	27	9067070080000	6707	9067080080000	6708
10.0	10.0	72	22	32	9067070100000	6707	9067080100000	6708
12.0	12.0	83	26	38	9067070120000	6707	9067080120000	6708
16.0	16.0	92	32	44	9067070160000	6707	9067080160000	6708
20.0	20.0	104	38	54	9067070200000	6707	9067080200000	6708
25.0	25.0	121	45	65	9067070250000	6707	9067080250000	6708

* Indicates reduced neck style

RF 100 VA/NF - high-performance roughing end mills for stainless steels

Based on our RF 100 end mill now with variable helix angles in combination with a newly developed roughing geometry. The result is a dramatic increase in tool life in comparison to conventional rough milling cutters with round or flat knuckle-type teeth. At the same time, the surface quality of the workpiece is improved to a peak-to-valley height of appr. $R_a = 2-3 \mu\text{m}$, making in many cases finishing operations unnecessary.

At the same time, the innovative design reduces power consumption in comparison to conventional RF 100 end mills allowing the application in unstable conditions and on less powerful machines.

Summary of advantages

- decreased cutting pressure and power consumption
- vibration-free operation
- increased feed rates possible
- increased surface qualities ($R_a = 2-3 \mu\text{m}$)
- improved tool life



Workpiece surface
 $R_a = 2-3 \mu\text{m}$

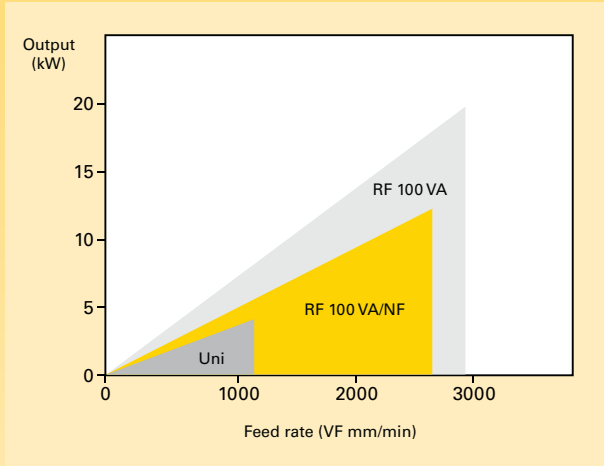

with neck clearance

36°

38°

with micro-corner protection for longer tool life

Material	Alloyed Steel		Tool Steel	Cast iron	Stainless steel		Aluminium		Ti-special alloys		H
	up to 28HRC	over 28HRC	up to 180 HB 30		over 180 HB 30	up to 28HRC	over 28HRC	up to 3% Si	over 3% Si	Ti-based	
RF 100 U	○	●	●	●					●		○
RF 100 U/HF	○	●	●	●					○		○
RF 100 F	●	○	○		○	●		○	○	●	
RF 100 VA	●	○	○	○	●	●		○	●	○	
RF 100 VA/NF	●	○	○	○	●	●			●	○	
RF 100 A							●	●			
RF 100 A/WF							●	●			
RF 100 Ti	○	●	○	○					●	○	○
RF 100 H		○		○							●
RF 100 SF	●	●	●	●	●	●	○	○	●	●	○

● = optimal suitability

○ = limited suitability

RF 100 VA/NF

Variable helix, Rougher, 4-flute, nano-A coated

Includes Series
INCH
3081
4262



TYPE	NF
HELIX ANGLE	36° 38°
NUMBER of TEETH	4

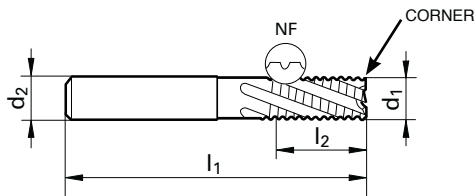

d₁ tolerance h10
d₂ tolerance h6
See table on page 150



Diameter	Shank Diameter	OAL	LOC	Corner	HA		HB	
(d1) Frac	(d2) Frac	(l1) Frac	(l2) Frac	Chamfer Inch	EDP No.	Series Number	EDP No.	Series Number
1/4	1/4	2 1/2	3/4	0.012	9030810063500	3081		
1/4	1/4	3 1/4	1 1/4	0.012	9042620063500	4262		
5/16	5/16	2 1/2	13/16	0.012	9030810079400	3081		
5/16	5/16	3 1/4	1 1/2	0.012	9042620079400	4262		
3/8	3/8	2 1/2	1	0.012	9030810095200	3081		
3/8	3/8	4	1 3/4	0.012	9042620095200	4262		
1/2	1/2	3 1/2	1 1/4	0.020			9030810127000	3081
1/2	1/2	4 1/2	2	0.020			9042620127000	4262
5/8	5/8	3 1/2	1 1/4	0.020			9030810158700	3081
5/8	5/8	5	2 1/4	0.020			9042620158700	4262
3/4	3/4	4	1 1/2	0.020			9030810190500	3081
3/4	3/4	5	2 1/4	0.020			9042620190500	4262
1	1	4	1 1/2	0.031			9030810254000	3081
1	1	5	2 1/4	0.031			9042620254000	4262

RF 100 VA/NF

Variable helix, Rougher, 4-flute, nano-A coated

Includes Series

METRIC
3696
3718
3733
3885

TYPE	NF
HELIX ANGLE	36° 38°
NUMBER of TEETH	4

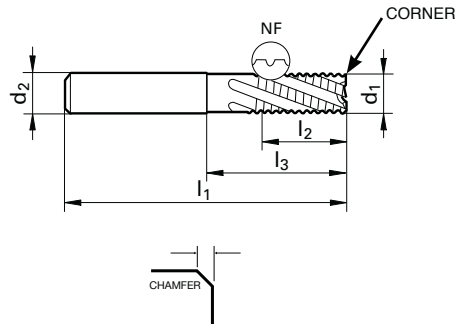

d_1 tolerance h10
 d_2 tolerance h6
 See table on page 150

Diameter	Shank Diameter	OAL	LOC	Reach	Corner	HA		HB	
						EDP No.	Series Number	EDP No.	Series Number
5.0	6.0	57	13	18	0.20	9036960050000	3696	9037180050000	3718
6.0	6.0	57	13	21	0.30	9036960060000	3696	9037180060000	3718
6.0	6.0	65	10	29	0.30	9037330060000	3733	9038850060000	3885
7.0	8.0	63	16	27	0.30	9036960070000	3696	9037180070000	3718
8.0	8.0	63	19	27	0.30	9036960080000	3696	9037180080000	3718
8.0	8.0	75	12	39	0.30	9037330080000	3733	9038850080000	3885
9.0	10.0	72	19	32	0.30	9036960090000	3696	9037180090000	3718
10.0	10.0	72	22	32	0.30	9036960100000	3696	9037180100000	3718
10.0	10.0	80	14	40	0.30	9037330100000	3733	9038850100000	3885
12.0	12.0	83	26	38	0.50	9036960120000	3696	9037180120000	3718
12.0	12.0	93	16	48	0.50	9037330120000	3733	9038850120000	3885
14.0	14.0	83	26	38	0.50	9036960140000	3696	9037180140000	3718
16.0	16.0	92	32	44	0.50	9036960160000	3696	9037180160000	3718
16.0	16.0	108	22	60	0.50	9037330160000	3733	9038850160000	3885
18.0	20.0	92	32	44	0.50	9036960180000	3696	9037180180000	3718
20.0	20.0	104	38	54	0.50	9036960200000	3696	9037180200000	3718
20.0	20.0	126	26	76	0.50	9037330200000	3733	9038850200000	3885
25.0	25.0	121	45	65	0.80	9036960250000	3696	9037180250000	3718

* Indicates reduced neck style

RF 100 VA/NF

Variable helix, Rougher, 4-flute, nano-Si[®] coated

Includes Series
METRIC
3060



TYPE	VA/NF
HELIX ANGLE	36° 38°
NUMBER of TEETH	4

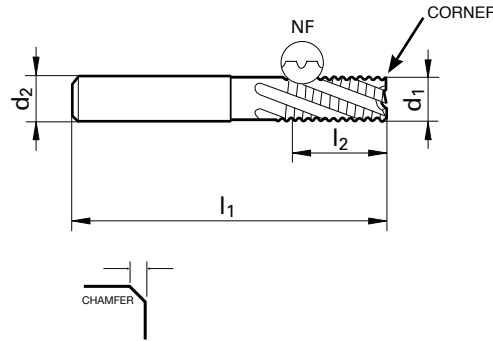

d₁ tolerance h10
d₂ tolerance h6
See table on page 150

Diameter	Shank Diameter	OAL	LOC	Corner		HA	HB
(d1) mm	(d2) mm	(l1) mm	(l2) mm	Chamfer mm	Flutes	EDP No.	Series Number
1/4	1/4	2 1/2	3/4	0.012	4	9030600063500	3060
5/16	5/16	2 1/2	13/16	0.012	4	9030600079400	3060
3/8	3/8	2 1/2	1	0.012	4	9030600095200	3060
1/2	1/2	3 1/2	1 1/4	0.020	4		9030600127000 3060
5/8	5/8	3 1/2	1 1/4	0.020	4		9030600158700 3060
3/4	3/4	4	1 1/2	0.020	4		9030600190500 3060
1	1	4	1 1/2	0.031	4		9030600254000 3060

nano-Si[®]

nano-Si[®] is an ultra-hard, heat resistant, multi-layer PVD coating developed by Guhring as an alternative to diamond coatings. Diamond or diamond-like coatings are limited in their application due to restrictions on the base material that they will properly adhere to. The new nano-Si[®] coating provides similar hardness values to diamond-like coatings but it can be applied to shock resistant carbide grades such as DK400N and DK460UF. This allows the coating to be successfully used on sub-micro grain carbide end mills and increase tool life by more than 50% in many high temperature alloy applications.

Medical / Aerospace / Energy



RF 100 A/WF - high-performance roughing end mills for aluminium and Al-alloys

Based on our RF 100 end mill with unequal helix angles in combination with a newly developed roughing geometry. The result is a dramatic increase in tool life in comparison to conventional rough milling cutters with round or flat knuckle-type teeth. At the same time, the surface quality of the workpiece is improved to a peak-to-valley height of appr. $R_a = 2-3 \mu\text{m}$, making in many cases finishing operations unnecessary.

Simultaneously, the innovative design reduces power consumption in comparison to conventional RF 100 end mills allowing the application in unstable conditions and on less powerful machines

Summary of advantages

- low cutting pressure and power consumption
- vibration-free operation
- increased feed rates possible
- increased surface qualities ($R_a = 2-3 \mu\text{m}$)
- longer tool life

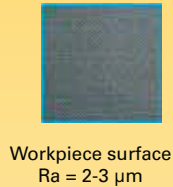
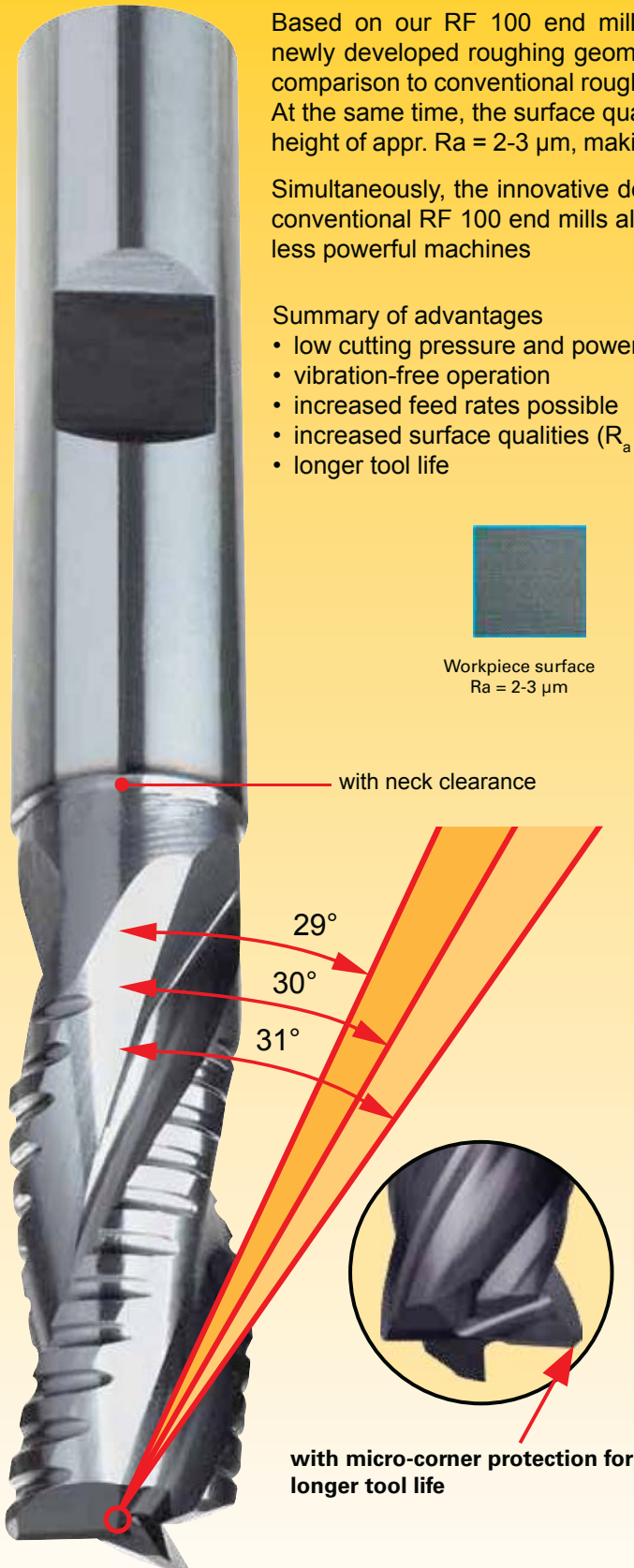

Type	Roughing end mill	RF 100 A/WF
Performance index	100%	140%
Workpiece surface	$R_a = 9-10 \mu\text{m}$ 	$R_a = 2-3 \mu\text{m}$
Tool life index	100%	180%
Power consumption	100%	130%
Cutting pressure	100%	125%

Material	Alloyed Steel		Tool Steel		Cast Iron		Stainless steel		Aluminium		Ti-special alloys		H	
	up to 28HRC	over 28HRC	up to 180 HB 30	over 180 HB 30	up to 28HRC	over 28HRC	up to 3% Si	over 3% Si	Ti-based	Ni-based	up to 52 HRC	above 52 HRC		
RF 100 U	○	●	●	●							○			
RF 100 U/HF	○	●	●	●							○		○	
RF 100 F	●	○	○		○	●		○	○	●				
RF 100 VA	●	○	○	○	●	●		○	●	○				
RF 100 VA/NF	●	○	○	○	●	●			●	○				
RF 100 A								●	●					
RF 100 A/WF								●	●					
RF 100 Ti	○	●	○	○						●	○	○		
RF 100 H		○		○									●	●
RF 100 SF	●	●	●	●	●	●	○	○	●	●	○			

● = optimal suitability

○ = limited suitability

RF 100 A/WF 3-Flute

Variable helix, Rougher, bright finish

Includes Series

INCH

4266



TYPE	WF
HELIX ANGLE	29° 30° 31°
NUMBER of TEETH	3

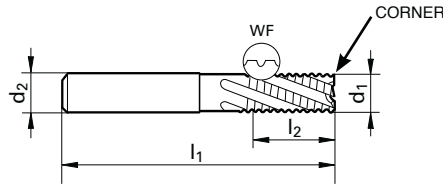

d₁ tolerance h10
d₂ tolerance h6
See table on page 150

Diameter	Shank Diameter	OAL	LOC	Corner	HA		HB	
					EDP No.	Series Number	EDP No.	Series Number
1/4	1/4	2 1/2	3/4	0.012	9042660063500	4266		
5/16	5/16	2 1/2	13/16	0.012	9042660079400	4266		
3/8	3/8	2 1/2	1	0.012	9042660095200	4266		
1/2	1/2	3 1/2	1 1/4	0.020			9042660127000	4266
5/8	5/8	3 1/2	1 1/4	0.020			9042660158700	4266
3/4	3/4	4	1 1/2	0.020			9042660190500	4266
1	1	4	1 1/2	0.031			9042660254000	4266

METRIC

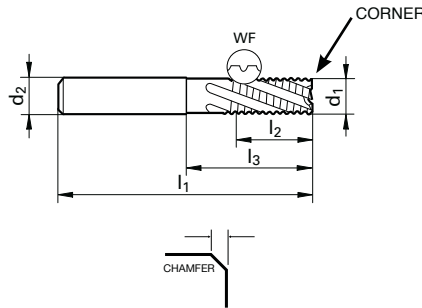

Includes Series

METRIC

3468

3469

3470

3471

Diameter	Shank Diameter	OAL	LOC	Reach	Corner	HA		HB	
						EDP No.	Series Number	EDP No.	Series Number
6.0	6.0	57	13	21	0.30	9034680060000	3468	9034690060000	3469
6.0	6.0	65	13	29	0.30	9034700060000	3470	9034710060000	3471
8.0	8.0	63	19	27	0.30	9034680080000	3468	9034690080000	3469
8.0	8.0	75	19	39	0.30	9034700080000	3470	9034710080000	3471
10.0	10.0	72	22	32	0.30	9034680100000	3468	9034690100000	3469
10.0	10.0	80	22	40	0.30	9034700100000	3470	9034710100000	3471
12.0	12.0	83	26	38	0.50	9034680120000	3468	9034690120000	3469
12.0	12.0	93	26	48	0.50	9034700120000	3470	9034710120000	3471
16.0	16.0	92	32	44	0.50	9034680160000	3468	9034690160000	3469
16.0	16.0	108	32	60	0.50	9034700160000	3470	9034710160000	3471
20.0	20.0	104	38	54	0.50	9034680200000	3468	9034690200000	3469
20.0	20.0	126	38	76	0.50	9034700200000	3470	9034710200000	3471
25.0	25.0	121	45	65	0.60	9034680250000	3468	9034690250000	3469

* Indicates reduced neck style

RF 100 A - high-performance end mills for aluminium and Al-alloys

RF 100 high-performance end mills excel thanks to variable helix angles which considerably reduce vibration. The uneven helix angle vastly improves surface quality for finishing operations and a considerably higher feed rate for slot drilling and roughing operations are also achieved.

With many applications, the complete milling process can be covered with one RF 100, which as well as increasing tool life and dimensional accuracy of the workpiece generates a considerable cost advantage.

Summary of advantages

- suitable for roughing and finishing
- up to 60% higher feed rates
- up to 4-times longer tool life
- vibration-free operation
- improved workpiece surface quality

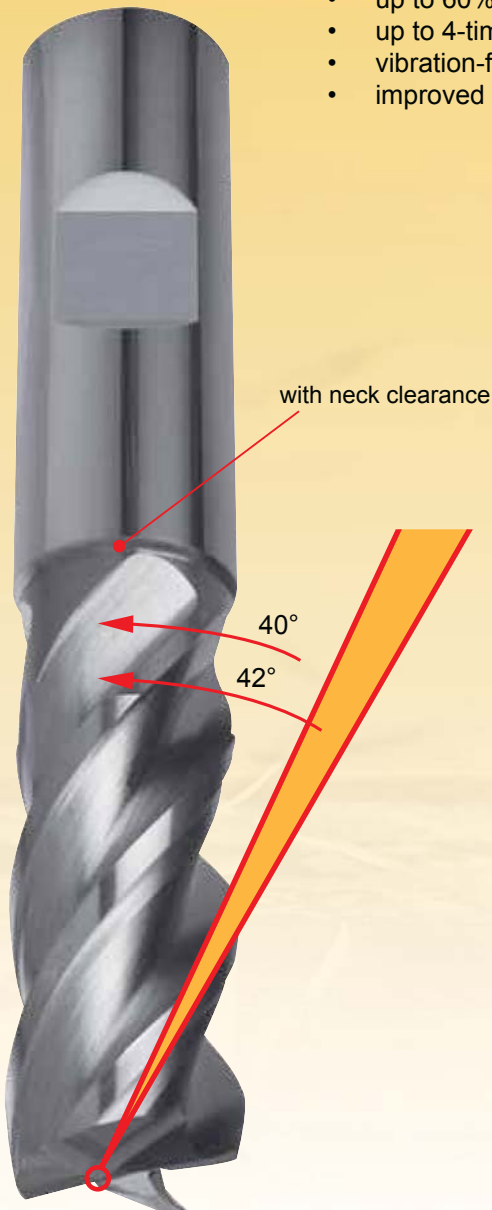

with micro-corner protection for longer tool life

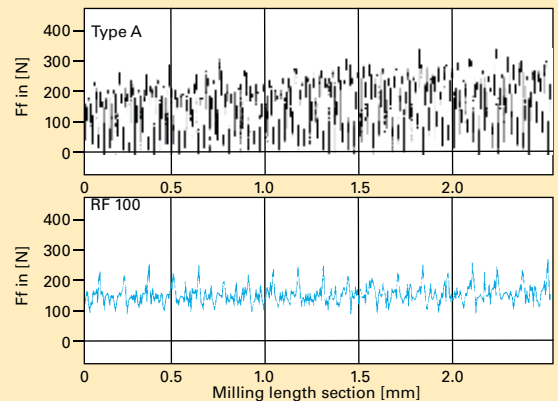

The cutting force comparison between a conventional milling cutter type N and the RF 100 shows a clearly quieter, more rigid operation of the RF 100.

RF 100 A 4-Flute

Variable helix, bright finish

Includes Series

INCH

3077



TYPE

W

HELIX ANGLE



NUMBER of TEETH

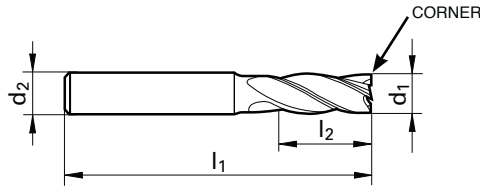

d_1 tolerance h10
 d_2 tolerance h6
 See table on page 150

Diameter	Shank Diameter	OAL	LOC	Corner	HA		HB	
(d1) Frac	(d2) Frac	(l1) Frac	(l2) Frac	Chamfer Inch	EDP No.	Series Number	EDP No.	Series Number
3/16	3/16	2	5/8	0.004	9030770047600	3077		
1/4	1/4	2 1/2	3/4	0.006	9030770063500	3077		
5/16	5/16	2 1/2	13/16	0.006	9030770079400	3077		
3/8	3/8	2 1/2	1	0.008	9030770095200	3077		
1/2	1/2	3 1/2	1 1/4	0.010			9030770127000	3077
5/8	5/8	3 1/2	1 1/4	0.014			9030770158700	3077
3/4	3/4	4	1 1/2	0.018			9030770190500	3077

METRIC

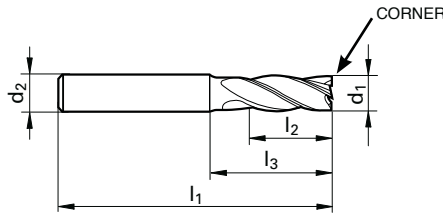

Includes Series

METRIC

3202

3319

Diameter	Shank Diameter	OAL	LOC	Reach	Corner	HA		HB	
(d1) mm	(d2) mm	(l1) mm	(l2) mm	*(l3) mm	Chamfer mm	EDP No.	Series Number	EDP No.	Series Number
4.0	6.0	57	11	18	0.10	9032020040000	3202	9033190040000	3319
5.0	6.0	57	13	18	0.10	9032020050000	3202	9033190050000	3319
6.0	6.0	57	13	21	0.15	9032020060000	3202	9033190060000	3319
8.0	8.0	63	19	27	0.15	9032020080000	3202	9033190080000	3319
10.0	10.0	72	22	32	0.20	9032020100000	3202	9033190100000	3319
12.0	12.0	83	26	38	0.20	9032020120000	3202	9033190120000	3319
16.0	16.0	92	32	44	0.35	9032020160000	3202	9033190160000	3319
20.0	20.0	104	38	54	0.45	9032020200000	3202	9033190200000	3319

* Indicates reduced neck style

RF 100 A 3-Flute

Variable helix, bright finish

Includes Series

INCH

4265



TYPE	W
HELIX ANGLE	39° 40° 41°
NUMBER of TEETH	3

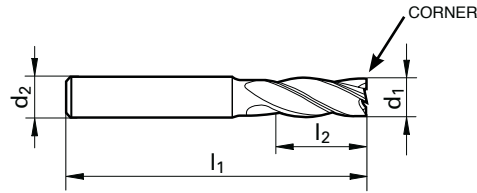

d₁ tolerance h10
d₂ tolerance h6
See table on page 150



Diameter	Shank Diameter	OAL	LOC	Corner	HA		HB	
(d1) Frac	(d2) Frac	(l1) Frac	(l2) Frac	Chamfer Inch	EDP No.	Series Number	EDP No.	Series Number
1/8	1/8	2	1/2	0.002	9042650031700	4265		
3/16	3/16	2	5/8	0.004	9042650047600	4265		
1/4	1/4	2 1/2	3/4	0.005	9042650063500	4265		
5/16	5/16	2 1/2	13/16	0.006	9042650079400	4265		
3/8	3/8	2 1/2	1	0.007	9042650095200	4265		
7/16	7/16	2 3/4	1	0.009	9042650111100	4265		
1/2	1/2	3 1/2	1 1/4	0.010			9042650127000	4265
5/8	5/8	3 1/2	1 1/4	0.013			9042650158700	4265
3/4	3/4	4	1 1/2	0.015			9042650190500	4265
1	1	4	1 1/2	0.020			9042650254000	4265

RF 100 A 3-Flute

Variable helix, bright finish

TYPE	W
HELIX ANGLE	39° 40° 41°
NUMBER of TEETH	3

d₁ tolerance h10
d₂ tolerance h6
See table on page 150

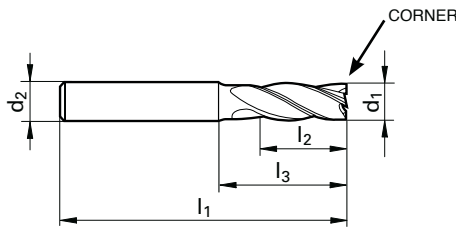

Includes Series	
METRIC	
	3472
	3473
	6702
	6703

Diameter	Shank Diameter	OAL	LOC	Reach	Corner	HA		HB	
						EDP No.	Series Number	EDP No.	Series Number
3.0	6.0	57	8	15	0.06	9034720030000	3472	9067020030000	6702
4.0	6.0	57	11	18	0.08	9034720040000	3472	9067020040000	6702
5.0	6.0	57	13	18	0.10	9034720050000	3472	9067020050000	6702
6.0	6.0	57	13	21	0.12	9034720060000	3472	9067020060000	6702
6.0	6.0	65	10	29	0.12	9034730060000	3473	9067030060000	6703
8.0	8.0	63	16	27	0.16	9034720080000	3472	9067020080000	6702
8.0	8.0	75	12	39	0.16	9034730080000	3473	9067030080000	6703
10.0	10.0	72	19	32	0.20	9034720100000	3472	9067020100000	6702
10.0	10.0	80	14	40	0.20	9034730100000	3473	9067030100000	6703
12.0	12.0	83	22	38	0.24	9034720120000	3472	9067020120000	6702
12.0	12.0	93	16	48	0.24	9034730120000	3473	9067030120000	6703
16.0	16.0	92	26	44	0.32	9034720160000	3472	9067020160000	6702
16.0	16.0	108	22	60	0.32	9034730160000	3473	9067030160000	6703
20.0	20.0	104	32	54	0.40	9034720200000	3472	9067020200000	6702
20.0	20.0	126	26	76	0.40	9034730200000	3473	9067030200000	6703

* Indicates reduced neck style

RF 100 Ti - high-performance roughing end mills for special and Ti-alloys

RF 100 high-performance end mills excel thanks to variable helix angles which considerably reduce vibration. The uneven helix angle vastly improves surface quality for finishing operations and a considerably higher feed rate for slot drilling and roughing operations are also achieved.

With many applications, the complete milling process can be covered with one RF 100, which as well as increasing tool life and dimensional accuracy of the workpiece generates a considerable cost advantage.

Summary of advantages

- suitable for roughing and finishing
- up to 60% higher feed rates
- up to 4-times longer tool life
- vibration-free operation
- improved workpiece surface quality

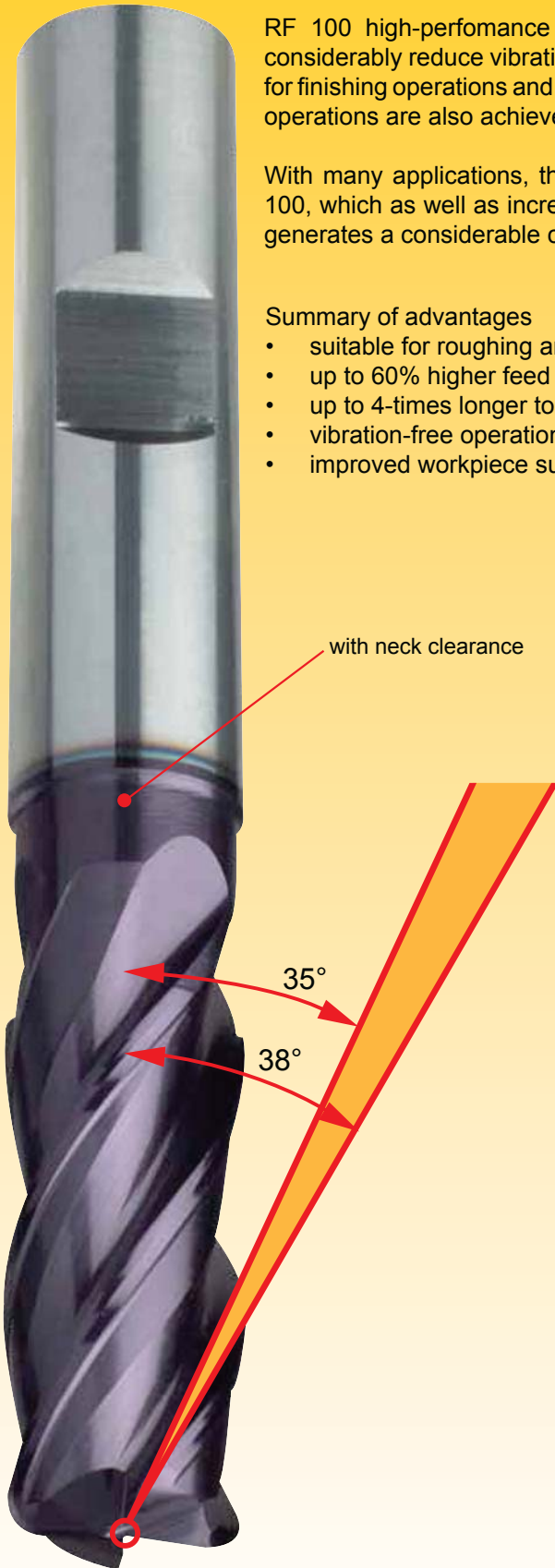

High wear protection through constant rake angle in radius area



Seamless radius area for high form and contour accuracy

Material	Alloyed Steel		Tool Steel		Cast iron		Stainless steel		Aluminium		Ti-special alloys		H
	up to 28HRC	over 28HRC	up to 180 HB 30	over 180 HB 30	up to 28HRC	over 28HRC	up to 3% Si	over 3% Si	Ti-based	Ni-based	up to 52 HRC	above 52 HRC	
RF 100 U	○	●	●	●							●	○	
RF 100 U/HF	○	●	●	●							○	○	
RF 100 F	●	○	○		○	●			○	○	●		
RF 100 VA	●	○	○	○	●	●			○	●	○		
RF 100 VA/NF	●	○	○	○	●	●				●	○		
RF 100 A							●	●					
RF 100 A/WF							●	●					
RF 100 Ti	○	●	○	○						●	○	○	
RF 100 H		○		○								●	●
RF 100 SF	●	●	●	●	●	●	○	○	●	●	○		

● = optimal suitability

○ = limited suitability

RF 100 Ti 4-flute

Variable helix, Super-A coated

Includes Series

INCH

3876



TYPE

N

HELIX ANGLE

35°
38°

NUMBER of TEETH

4

d₁ tolerance h10
d₂ tolerance h6
See table on page 150

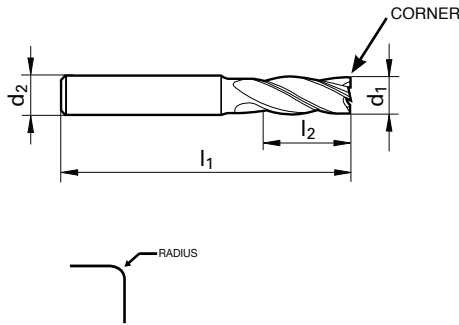

Diameter	Shank Diameter	OAL	LOC	Corner	HA		HB	
(d1) Frac	(d2) Frac	(l1) Frac	(l2) Frac	Radius Inch	EDP No.	Series Number	EDP No.	Series Number
1/4	1/4	2 1/2	3/4	0.015	9038760063520	3876		
1/4	1/4	2 1/2	3/4	0.031	9038760063540	3876		
5/16	5/16	2 1/2	13/16	0.031	9038760079440	3876		
3/8	3/8	2 1/2	1	0.031	9038760095240	3876		
7/16	7/16	2 3/4	1	0.031	9038760111140	3876		
1/2	1/2	3 1/2	1 1/4	0.031			9038760127040	3876
1/2	1/2	3 1/2	1 1/4	0.040			9038760127050	3876
1/2	1/2	3 1/2	1 1/4	0.062			9038760127060	3876
1/2	1/2	3 1/2	1 1/4	0.090			9038760127070	3876
5/8	5/8	3 1/2	1 1/4	0.031			9038760158740	3876
5/8	5/8	3 1/2	1 1/4	0.062			9038760158760	3876
3/4	3/4	4	1 1/2	0.062			9038760190560	3876
3/4	3/4	4	1 1/2	0.090			9038760190570	3876
3/4	3/4	4	1 1/2	0.125			9038760190590	3876
1	1	4	1 1/2	0.062			9038760254060	3876
1	1	4	1 1/2	0.090			9038760254070	3876
1	1	4	1 1/2	0.125			9038760254090	3876

RF 100 Ti 4-Flute

Variable helix, Super-A coated

Includes Series

METRIC

3498

3499



TYPE	N
HELIX ANGLE	35° 38°
NUMBER of TEETH	4

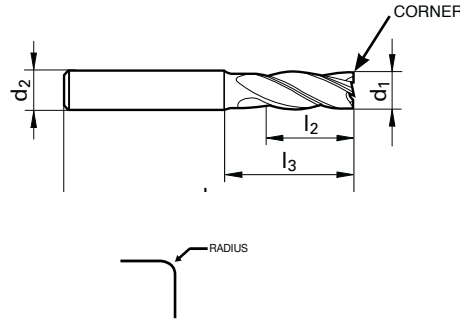

d₁ tolerance h10
d₂ tolerance h6
See table on page 150

Diameter	Shank Diameter	OAL	LOC	Reach	Corner	HA		HB	
						EDP No.	Series Number	EDP No.	Series Number
6.0	6.0	57	13	21	0.5	9034980060050	3498	9034990060050	3499
6.0	6.0	57	13	21	0.8	9034980060080	3498	9034990060080	3499
6.0	6.0	57	13	21	1.0	9034980060100	3498	9034990060100	3499
6.0	6.0	57	13	21	1.5	9034980060150	3498	9034990060150	3499
6.0	6.0	57	13	21	2.0	9034980060200	3498	9034990060200	3499
8.0	8.0	63	19	27	0.5	9034980080050	3498	9034990080050	3499
8.0	8.0	63	19	27	0.8	9034980080080	3498	9034990080080	3499
8.0	8.0	63	19	27	1.0	9034980080100	3498	9034990080100	3499
8.0	8.0	63	19	27	1.5	9034980080150	3498	9034990080150	3499
8.0	8.0	63	19	27	2.0	9034980080200	3498	9034990080200	3499
10.0	10.0	72	22	32	0.5	9034980100050	3498	9034990100050	3499
10.0	10.0	72	22	32	0.8	9034980100080	3498	9034990100080	3499
10.0	10.0	72	22	32	1.0	9034980100100	3498	9034990100100	3499
10.0	10.0	72	22	32	1.5	9034980100150	3498	9034990100150	3499
10.0	10.0	72	22	32	2.0	9034980100200	3498	9034990100200	3499
12.0	12.0	83	26	38	0.5	9034980120050	3498	9034990120050	3499
12.0	12.0	83	26	38	0.8	9034980120080	3498	9034990120080	3499
12.0	12.0	83	26	38	1.0	9034980120100	3498	9034990120100	3499
12.0	12.0	83	26	38	1.5	9034980120150	3498	9034990120150	3499
12.0	12.0	83	26	38	2.0	9034980120200	3498	9034990120200	3499
12.0	12.0	83	26	38	2.5	9034980120250	3498	9034990120250	3499
12.0	12.0	83	26	38	3.0	9034980120300	3498	9034990120300	3499
12.0	12.0	83	26	38	3.2	9034980120310	3498	9034990120310	3499
12.0	12.0	83	26	38	4.0	9034980120400	3498	9034990120400	3499
16.0	16.0	92	32	44	0.5	9034980160050	3498	9034990160050	3499
16.0	16.0	92	32	44	0.8	9034980160080	3498	9034990160080	3499
16.0	16.0	92	32	44	1.0	9034980160100	3498	9034990160100	3499
16.0	16.0	92	32	44	1.5	9034980160150	3498	9034990160150	3499
16.0	16.0	92	32	44	2.0	9034980160200	3498	9034990160200	3499
16.0	16.0	92	32	44	2.5	9034980160250	3498	9034990160250	3499
16.0	16.0	92	32	44	3.0	9034980160300	3498	9034990160300	3499
16.0	16.0	92	32	44	3.2	9034980160310	3498	9034990160310	3499
16.0	16.0	92	32	44	4.0	9034980160400	3498	9034990160400	3499
20.0	20.0	104	38	54	0.5	9034980200050	3498	9034990200050	3499

* Indicates reduced neck style

Continued on next page

RF 100 Ti 4-Flute

Variable helix, Super-A coated

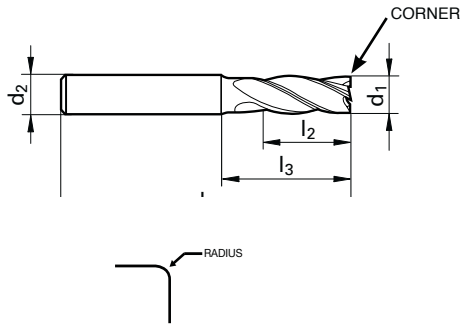

(Continued from previous page)

Diameter	Shank Diameter	OAL	LOC	Reach	Corner	HA		HB	
(d1) mm	(d2) mm	(l1) mm	(l2) mm	*(l3) mm	Radius mm	EDP No.	Series Number	EDP No.	Series Number
20.0	20.0	104	38	54	1.0	9034980200100	3498	9034990200100	3499
20.0	20.0	104	38	54	1.5	9034980200150	3498	9034990200150	3499
20.0	20.0	104	38	54	2.0	9034980200200	3498	9034990200200	3499
20.0	20.0	104	38	54	2.5	9034980200250	3498	9034990200250	3499
20.0	20.0	104	38	54	3.0	9034980200300	3498	9034990200300	3499
20.0	20.0	104	38	54	3.2	9034980200310	3498	9034990200310	3499
20.0	20.0	104	38	54	4.0	9034980200400	3498	9034990200400	3499
25.0	25.0	121	45	65	1.5	9034980250150	3498	9034990250150	3499
25.0	25.0	121	45	65	2.0	9034980250200	3498	9034990250200	3499
25.0	25.0	121	45	65	2.5	9034980250250	3498	9034990250250	3499
25.0	25.0	121	45	65	3.0	9034980250300	3498	9034990250300	3499
25.0	25.0	121	45	65	3.2	9034980250310	3498	9034990250310	3499
25.0	25.0	121	45	65	4.0	9034980250400	3498	9034990250400	3499
25.0	25.0	121	45	65	5.0	9034980250500	3498	9034990250500	3499

* Indicates reduced neck style

RF 100 S/F - high-performance semi-roughing end mills for materials up to 1600 N/mm² (48 HRC)

Based on our 4-fluted RF 100 U the RF 100 S/F has a higher, more rigid web paired with 5 cutting edges. In addition, its innovative flute geometry ensures optimal chip evacuation.

The range of application includes super finishing and HSC finishing as well as semi-roughing operations (HPC-machining), i.e. feed widths (a_e) up to 0.5xD with close to complete cutting length.



Summary of advantages

- suitable for semi-roughing (HPC) and HSC-finishing
- extremely high form accuracy
- vibration-free operation
- optimized flute geometry
- high feed rates possible
- optimal surface quality
- increased tool life

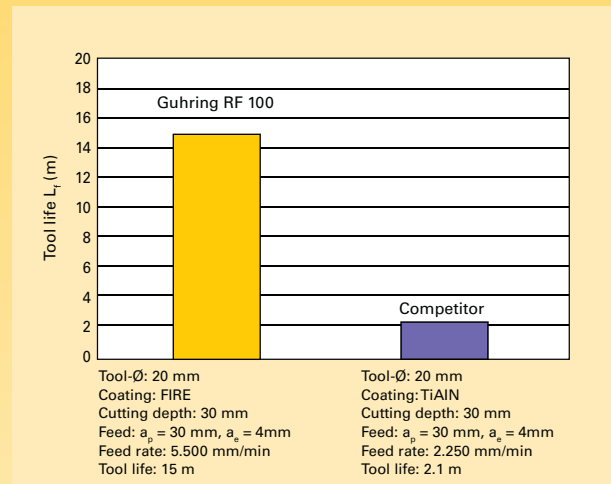

Tool life comparison:
Semi-roughing in 48 HRC the RF 100 S/F achieves more than 7 times the tool life in comparison to conventional end mills.

Material	Alloyed Steel		Tool Steel		Cast iron		Stainless steel		Aluminium		Ti-special alloys		H	
	up to 28Hrc	over 28Hrc	up to 180 HB 30	over 180 HB 30	up to 28Hrc	over 28Hrc	up to 3% Si	over 3% Si	Ti-based	Ni-based	up to 52 HRC	above 52 HRC		
RF 100 U	○	●	●	●						●		○		
RF 100 U/HF	○	●	●	●						○		○		
RF 100 F	●	○	○		○	●		○	○	●				
RF 100 VA	●	○	○	○	●	●		○	●	○				
RF 100 VA/NF	●	○	○	○	●	●			●	○				
RF 100 A							●	●						
RF 100 A/WF							●	●						
RF 100 Ti	○	●	○	○						●	○	○		
RF 100 H		○		○									●	●
RF 100 SF	●	●	●	●	●	●	○	○	●	●	○			

● = optimal suitability

○ = limited suitability

RF 100 S/F 5-flute

Variable flute, FIREX® coated

Includes Series

INCH

4263

4264



TYPE **NH**

HELIX ANGLE **45°**

NUMBER of TEETH **5**

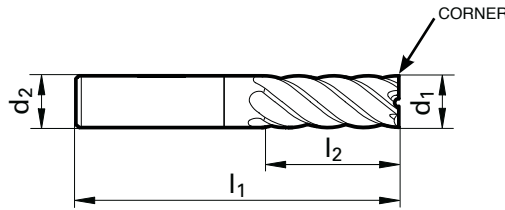

d₁ tolerance h10
d₂ tolerance h6
See table on page 150



Diameter	Shank Diameter	OAL	LOC	Corner	HA		HB	
					EDP No.	Series Number	EDP No.	Series Number
(d1) Frac	(d2) Frac	(l1) Frac	(l2) Frac	Chamfer Inch				
3/16	3/16	2	5/8	0.002	9042630047600	4263		
3/16	3/16	2 1/2	3/4	0.002	9042640047600	4264		
1/4	1/4	2 1/2	3/4	0.004	9042630063500	4263		
1/4	1/4	3 1/4	1 1/4	0.004	9042640063500	4264		
5/16	5/16	2 1/2	13/16	0.004	9042630079400	4263		
5/16	5/16	3 1/4	1 1/2	0.004	9042640079400	4264		
3/8	3/8	2 1/2	1	0.004	9042630095200	4263		
3/8	3/8	4	1 3/4	0.004	9042640095200	4264		
7/16	7/16	2 3/4	1	0.006	9042630111100	4263		
7/16	7/16	4 1/2	2	0.006	9042640111100	4264		
1/2	1/2	3 1/2	1 1/4	0.006			9042630127000	4263
1/2	1/2	4 1/2	2	0.006			9042640127000	4264
5/8	5/8	3 1/2	1 1/4	0.006			9042630158700	4263
5/8	5/8	5	2 1/4	0.006			9042640158700	4264
3/4	3/4	4	1 1/2	0.006			9042630190500	4263
3/4	3/4	5	2 1/4	0.006			9042640190500	4264
1	1	4	1 1/2	0.012			9042630254000	4263
1	1	5	2 1/4	0.012			9042640254000	4264
1 1/4	1 1/4	6	2 1/2	0.012			9042630317500	4263
1 1/4	1 1/4	7 1/2	4	0.012			9042640317500	4264

RF 100 S/F 5-Flute

Variable flute, FIREX® coated

Includes Series

METRIC

3897

3898

6709

6710



TYPE	NH
HELIX ANGLE	45°
NUMBER of TEETH	5

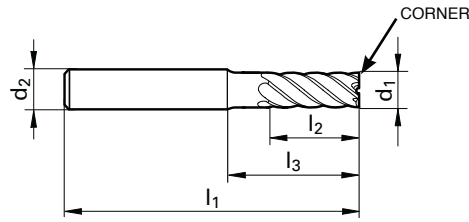

d₁ tolerance h10
d₂ tolerance h6
See table on page 150

Diameter	Shank Diameter	OAL	LOC	Reach	Corner	HA		HB	
(d1) mm	(d2) mm	(l1) mm	(l2) mm	*(l3) mm	Chamfer mm	EDP No.	Series Number	EDP No.	Series Number
4.0	6.0	57	11	18	0.05	9067090040000	6709	9067100040000	6710
4.0	6.0	65	12	23	0.05	9038970040000	3897	9038980040000	3898
5.0	6.0	57	13	18	0.05	9067090050000	6709	9067100050000	6710
5.0	6.0	65	15	26	0.05	9038970050000	3897	9038980050000	3898
6.0	6.0	57	13	21	0.05	9067090060000	6709	9067100060000	6710
6.0	6.0	65	18	29	0.05	9038970060000	3897	9038980060000	3898
8.0	8.0	63	19	27	0.10	9067090080000	6709	9067100080000	6710
8.0	8.0	75	24	39	0.10	9038970080000	3897	9038980080000	3898
10.0	10.0	72	22	32	0.10	9067090100000	6709	9067100100000	6710
10.0	10.0	80	30	40	0.10	9038970100000	3897	9038980100000	3898
12.0	12.0	83	26	38	0.15	9067090120000	6709	9067100120000	6710
12.0	12.0	93	36	48	0.15	9038970120000	3897	9038980120000	3898
16.0	16.0	92	32	44	0.15	9067090160000	6709	9067100160000	6710
16.0	16.0	108	48	60	0.15	9038970160000	3897	9038980160000	3898
20.0	20.0	104	38	54	0.15	9067090200000	6709	9067100200000	6710
20.0	20.0	126	60	76	0.15	9038970200000	3897	9038980200000	3898
25.0	25.0	121	45	65	0.20	9067090250000	6709	9067100250000	6710

* Indicates reduced neck style

RF 100 S/F 6-Flute

Variable helix, FIREX® coated

Includes Series

INCH

3115



TYPE

NH

HELIX ANGLE

44°
45°
46°

NUMBER of TEETH

6

d₁ tolerance h10
d₂ tolerance h6
See table on page 150

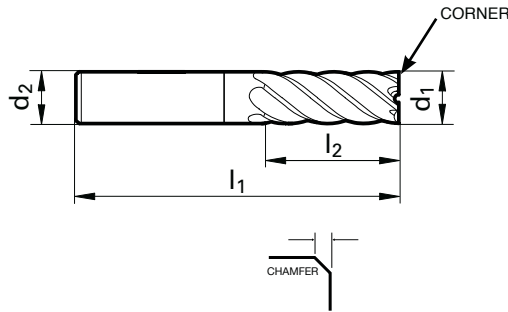

Diameter	Shank Diameter	OAL	LOC		HA	
(d1) Frac	(d2) Frac	(l1) Frac	(l2) Frac	Chamfer Inch	EDP No.	Series Number
5/16	5/16	2 1/2	13/16	0.004	9031150079400	3115
3/8	3/8	2 1/2	1	0.004	9031150095200	3115
1/2	1/2	3	1	0.006	9031150127000	3115
5/8	5/8	3 1/2	1 1/4	0.006	9031150158700	3115
3/4	3/4	4	1 1/2	0.006	9031150190500	3115
1	1	4	1 1/2	0.012	9031150254000	3115

METRIC

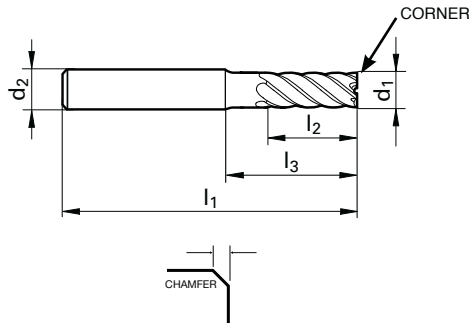

Includes Series

METRIC

3631

3632

Diameter	Shank Diameter	OAL	LOC	Reach	Corner	HA	HB		
(d1) Frac	(d2) Frac	(l1) Frac	(l2) Frac	*(l3) Frac	Chamfer Inch	EDP No.	Series Number	EDP No.	Series Number
8.0	8.0	63	19	27	0.10	9036310080000	3631	9036320080000	3632
10.0	10.0	72	22	32	0.10	9036310100000	3631	9036320100000	3632
12.0	12.0	83	26	38	0.15	9036310120000	3631	9036320120000	3632
16.0	16.0	92	32	44	0.15	9036310160000	3631	9036320160000	3632
20.0	20.0	104	38	54	0.15	9036310200000	3631	9036320200000	3632
25.0	25.0	121	45	65	0.20	9036310250000	3631	9036320250000	3632

* Indicates reduced neck style

RF 100 H - high-performance roughing end mills for hardened steels up to 60 HRC

RF 100 high-performance end mills excel thanks to variable helix angles which considerably reduce vibration. The uneven helix angle vastly improves surface quality for finishing operations.

Innovative design with core stability enables roughing operations up to $1xD$ in materials up to 54 HRC as well as finishing operations over the entire cutting edge length (up to $2.5xD$) in materials up to 60 HRC. Also applicable with HPC strategy for roughing materials over 60 HRC.

Summary of advantages

- suitable for roughing and finishing
- up to 60% higher feed rates
- up to 4-times longer tool life
- vibration-free operation
- improved workpiece surface quality

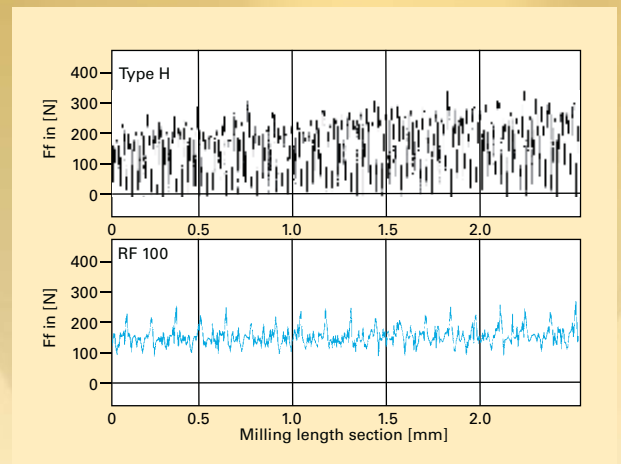
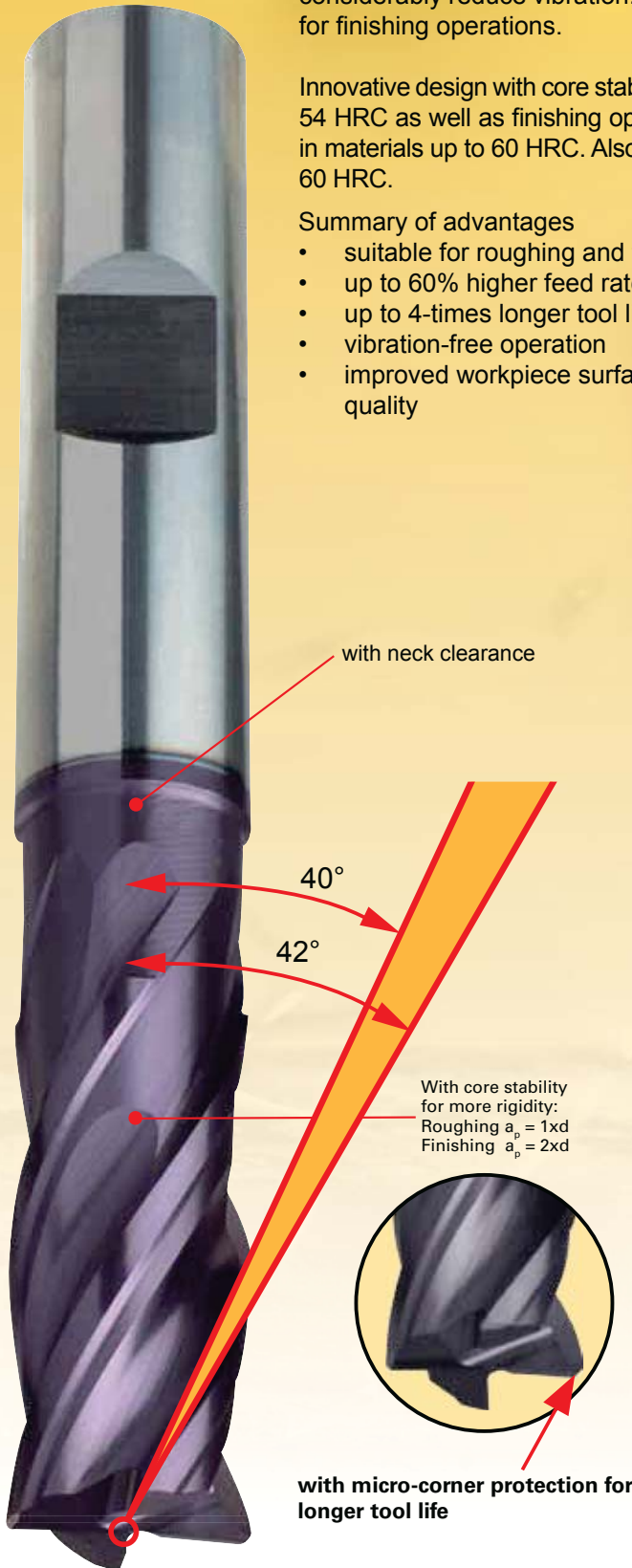

The cutting force comparison between a conventional milling cutter type N and the RF 100 shows a clearly quieter, more rigid operation of the RF 100.

RF 100 H 4-Flute

Variable helix, TiALN coated

Includes Series	
METRIC	
3895	
3896	



TYPE	H
HELIX ANGLE	40° 42°
NUMBER of TEETH	4

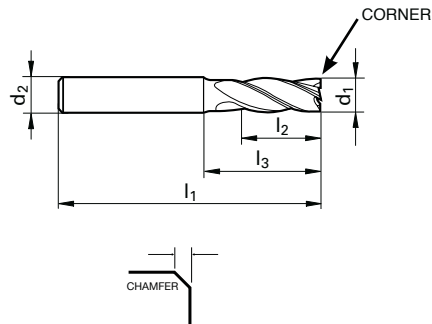

d₁ tolerance h10
d₂ tolerance h6
See table on page 150

Diameter	Shank Diameter	OAL	LOC	Reach	Corner	HA		HB	
						EDP No.	Series Number	EDP No.	Series Number
6.0	6.0	57	13	21	0.20	9038950060000	3895	9038960060000	3896
8.0	8.0	63	19	27	0.25	9038950080000	3895	9038960080000	3896
10.0	10.0	72	22	32	0.30	9038950100000	3895	9038960100000	3896
12.0	12.0	83	26	38	0.35	9038950120000	3895	9038960120000	3896
16.0	16.0	92	32	44	0.50	9038950160000	3895	9038960160000	3896
20.0	20.0	104	38	54	0.60	9038950200000	3895	9038960200000	3896

* Indicates reduced neck style

DIAMOND-TECH

High-Performance Cutting Tools
for Composite and Aerospace Materials

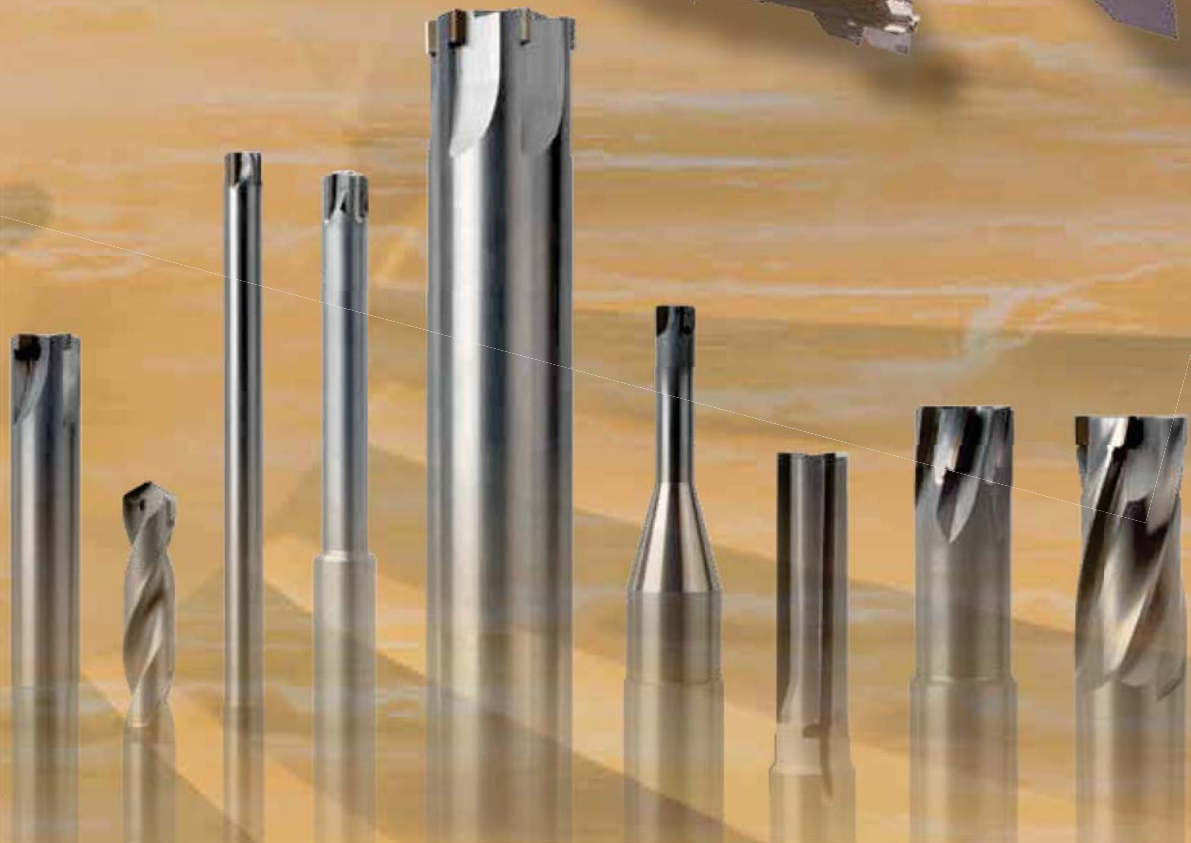































Standard and highly complex PCD special tools

Guhring's PCD tool range includes drills, milling cutters and reamers, as well as tools with interchangeable inserts. Additionally, Guhring develops, designs and produces customer specific special tools for highly complex machining tasks. Some examples are PCD-tipped finishing reamers for the machining of valve seats in the automotive industry, or combination tools enabling different machining operations with one single tool.



PCD and diamond coated carbide end mills and routers are well suited for machining abrasive materials that are common in the aerospace industry. Carbon fiber reinforced polymers (CFRP composites) are lightweight and high strength materials but their woven fibers and multi-layer construction are challenging for traditional cutting materials. The Diamond-Tech line of milling cutters offers a solution for these specialized applications. Guhring also designs and builds application specific cutters for CFRP and other composite materials.



Standard	Tooth profile	Helix angle	No. of Flutes	Length	Tool description	Tool material Surface finish	Gurthing no.	Gurthing no.	Diameter Range	Page
							HA	HB		
DL 100 X2 - High performance PCD end mill for aluminum and composites						PCD				
Inch	--	0°				Bright	3867		1/4 - 3/4	69
Inch	--	0°				Bright	3870		1/2 - 1	69
Coolant fed high performance PCD end mill for aluminum and composites						PCD				
Metric	--	0°				Bright	5492		4 - 20	70
Metric	--	0°				Bright	5493		4 - 20	70
Metric	--	0°				Bright	5495		14 - 20	71
Metric	--	0°				Bright	5496		14 - 20	71
CR 100 Carbide Routers - diamond coated for composite materials						Carbide				
Metric	--	0°				Diamond	6717		4 - 16	73
Metric	--	0°				Diamond	6718		6 - 16	73
Metric	--	0°				Diamond	6719		4 - 16	73
Metric	--	0°				Diamond	6720		4 - 16	73

FRACTIONAL

DL 100 X2 End Mills

2-flute, center cutting, PCD Tipped



Includes Series
INCH
3867

TYPE **N**

NUMBER of TEETH **2**

SHANK **HA**

d_1 tolerance h10
 d_2 tolerance h6
 See table on page 150

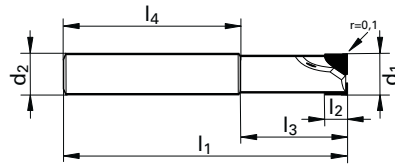

Diameter	Shank Diameter	OAL	LOC	No. of Flutes	EDP No.	Series Number
(d1) Frac	(d2) Frac	(l1) Frac	(l2) Frac			
1/4	0.250	2.50	0.75	2	9038670006350	3867
3/8	0.375	3.00	0.75	2	9038670009520	3867
1/2	0.500	3.00	1.00	2	9038670012700	3867
3/4	0.750	4.00	1.00	2	9038670019050	3867

FRACTIONAL

DL 100 X2 End Mills

3-flute, center cutting, PCD Tipped



Includes Series
INCH
3870

TYPE **N**

NUMBER of TEETH **3**

SHANK **HA**

d_1 tolerance h10
 d_2 tolerance h6
 See table on page 150

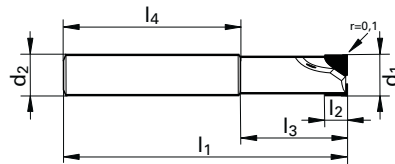

Diameter	Shank Diameter	OAL	LOC	No. of Flutes	EDP No.	Series Number
(d1) Frac	(d2) Frac	(l1) Frac	(l2) Frac			
1/2	0.50	3.00	0.50	3	9038700012700	3870
3/4	0.75	3.00	0.50	3	9038700019050	3870
1	1.00	4.00	1.00	3	9038700025400	3870

DL 100 X2 End Mills

2-flute, center cutting, PCD Tipped

Includes Series

METRIC

5492

5493

TYPE

N

d₁ tolerance h10
d₂ tolerance h6
See table on page 150

NUMBER of TEETH



2

SHANK

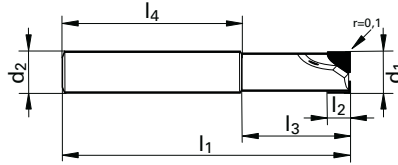

Diameter	Shank Diameter	OAL	LOC			No. of Flutes	EDP No.	Series Number
(d1) mm	(d2) mm	(l1) mm	(l2) mm	*(l3) mm	(l4) mm			
4.0	6.0	51.0	6.0	15.0	36.0	2	9054920004000	5492
4.0	6.0	70.0	6.0	15.0	55.0	2	9054930004000	5493
5.0	6.0	51.0	8.0	15.0	36.0	2	9054920005000	5492
5.0	6.0	70.0	8.0	15.0	55.0	2	9054930005000	5493
6.0	6.0	57.0	8.0	21.0	36.0	2	9054920006000	5492
6.0	6.0	75.0	8.0	21.0	54.0	2	9054930006000	5493
8.0	8.0	63.0	8.0	27.0	36.0	2	9054920008000	5492
8.0	8.0	63.0	12.0	27.0	36.0	2	9054920008001	5492
8.0	8.0	100.0	8.0	27.0	73.0	2	9054930008000	5493
8.0	8.0	100.0	12.0	27.0	73.0	2	9054930008001	5493
10.0	10.0	72.0	8.0	32.0	40.0	2	9054920010000	5492
10.0	10.0	72.0	16.0	32.0	40.0	2	9054920010001	5492
10.0	10.0	100.0	8.0	32.0	68.0	2	9054930010000	5493
10.0	10.0	100.0	16.0	32.0	68.0	2	9054930010001	5493
12.0	12.0	83.0	8.0	38.0	45.0	2	9054920012000	5492
12.0	12.0	83.0	16.0	38.0	45.0	2	9054920012001	5492
12.0	12.0	100.0	8.0	38.0	62.0	2	9054930012000	5493
12.0	12.0	100.0	16.0	38.0	62.0	2	9054930012001	5493
14.0	14.0	83.0	8.0	38.0	45.0	2	9054920014000	5492
14.0	14.0	83.0	16.0	38.0	45.0	2	9054920014001	5492
14.0	14.0	100.0	8.0	38.0	62.0	2	9054930014000	5493
14.0	14.0	100.0	16.0	38.0	62.0	2	9054930014001	5493
16.0	16.0	100.0	12.0	52.0	48.0	2	9054920016000	5492
16.0	16.0	100.0	20.0	52.0	48.0	2	9054920016001	5492
16.0	16.0	150.0	12.0	52.0	98.0	2	9054930016000	5493
16.0	16.0	150.0	20.0	52.0	98.0	2	9054930016001	5493
18.0	18.0	100.0	12.0	52.0	48.0	2	9054920018000	5492
18.0	18.0	100.0	20.0	52.0	48.0	2	9054920018001	5492
18.0	18.0	125.0	12.0	52.0	73.0	2	9054930018000	5493
18.0	18.0	125.0	20.0	52.0	73.0	2	9054930018001	5493
18.0	18.0	150.0	20.0	52.0	98.0	2	9054930018002	5493
18.0	18.0	150.0	12.0	52.0	98.0	2	9054930018003	5493
20.0	20.0	100.0	12.0	52.0	48.0	2	9054920020000	5492
20.0	20.0	100.0	20.0	52.0	48.0	2	9054920020001	5492
20.0	20.0	150.0	12.0	50.0	100.0	2	9054930020000	5493
20.0	20.0	150.0	20.0	50.0	100.0	2	9054930020001	5493

* Indicates reduced neck style

DL 100 X2 End Mills

3-flute, center cutting, Coolant Fed, PCD Tipped

Includes Series

METRIC

5495

5496



TYPE **N**

NUMBER of TEETH **3**

SHANK **HA**

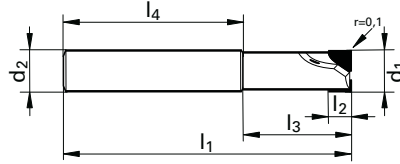

d₁ tolerance h10
 d₂ tolerance h6
 See table on page 150

Diameter	Shank Diameter	OAL	LOC			No. of Flutes	EDP No.	Series Number
(d1) mm	(d2) mm	(l1) mm	(l2) mm	*(l3) mm	(l4) mm			
14.0	14.0	83.0	8.0	38.0	45.0	3	9054950014000	5495
14.0	14.0	83.0	16.0	38.0	45.0	3	9054950014001	5495
14.0	14.0	100.0	8.0	38.0	62.0	3	9054960014000	5496
14.0	14.0	100.0	16.0	38.0	62.0	3	9054960014001	5496
16.0	16.0	100.0	12.0	52.0	48.0	3	9054950016000	5495
16.0	16.0	100.0	20.0	52.0	48.0	3	9054950016001	5495
16.0	16.0	150.0	12.0	52.0	98.0	3	9054960016000	5496
16.0	16.0	150.0	20.0	52.0	98.0	3	9054960016001	5496
18.0	18.0	100.0	12.0	52.0	48.0	3	9054950018000	5495
18.0	18.0	100.0	20.0	52.0	48.0	3	9054950018001	5495
18.0	18.0	150.0	12.0	52.0	98.0	3	9054960018000	5496
18.0	18.0	150.0	20.0	52.0	98.0	3	9054960018001	5496
20.0	20.0	100.0	12.0	50.0	50.0	3	9054950020000	5495
20.0	20.0	100.0	20.0	50.0	50.0	3	9054950020001	5495
20.0	20.0	150.0	12.0	50.0	100.0	3	9054960020000	5496
20.0	20.0	150.0	20.0	50.0	100.0	3	9054960020001	5496

* Indicates reduced neck style

CR 100 Carbide Routers

Diamond coated, multi-flute design for composite materials

Carbide Slotting Router Features:

- For slot and periphery milling in composite materials
- Capable of roughing and finishing in one pass
- Extremely rigid design minimizes deflection and vibration
- Flute geometry promotes shearing action, minimizes delamination and burrs
- Multiple flutes for maximum material removal, non center cutting
- 0.006" chamfer for micro-edge protection and extended tool life

Plunging Carbide Router Features:

- 118° drill point allows for plunging operations, can also be used for slotting and periphery milling
- Multiple flutes for maximum material removal
- Extremely rigid design minimizes deflection and vibration
- Flute geometry promotes shearing action, minimizes delamination and burrs



CR 100 Carbide Routers

Includes Series

METRIC

6717

6718

6719

6720

for fiber-reinforced plastics

TYPE

N

d₁ tolerance h10
d₂ tolerance h6
See table on page 150

SHANK

HA

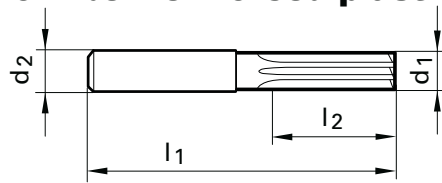

Diameter	Shank Diameter	OAL	LOC	No. of Flutes	EDP No.	Series Number
(d1) mm	(d2) mm	(l1) mm	(l2) mm			
4.0	6.0	57.0	10.0	6	9067170004000	6717
6.0	6.0	65.0	15.0	8	9067170006000	6717
8.0	8.0	75.0	20.0	10	9067170008000	6717
10.0	10.0	80.0	25.0	12	9067170010000	6717
12.0	12.0	93.0	32.0	14	9067170012000	6717
16.0	16.0	108.0	32.0	14	9067170016000	6717

Multi-flute slotting router



Diameter	Shank Diameter	OAL	LOC	No. of Flutes	EDP No.	Series Number
(d1) mm	(d2) mm	(l1) mm	(l2) mm			
6.0	6.0	70.0	24.0	8	9067180006000	6718
8.0	8.0	80.0	32	10	9067180008000	6718
10.0	10.0	90.0	40.0	12	9067180010000	6718
12.0	12.0	110.0	48.0	14	9067180012000	6718
16.0	16.0	130.0	64.0	14	9067180016000	6718

Multi-flute slotting router - Coolant fed



Diameter	Shank Diameter	OAL	LOC	No. of Flutes	EDP No.	Series Number
(d1) mm	(d2) mm	(l1) mm	(l2) mm			
4.0	6.0	57.0	10.0	6	9067190004000	6719
6.0	6.0	65.0	15.0	8	9067190006000	6719
8.0	8.0	75.0	20.0	10	9067190008000	6719
10.0	10.0	80.0	25.0	12	9067190010000	6719
12.0	12.0	93.0	32.0	14	9067190012000	6719
16.0	16.0	108.0	32.0	14	9067190016000	6719

Multi-flute plunging router



Diameter	Shank Diameter	OAL	LOC	No. of Flutes	EDP No.	Series Number
(d1) mm	(d2) mm	(l1) mm	(l2) mm			
4.0	4.0	55.0	12.0	6	9067200004000	6720
6.0	6.0	65.0	18.0	8	9067200006000	6720
8.0	8.0	75.0	24.0	10	9067200008000	6720
10.0	10.0	80.0	30.0	12	9067200010000	6720
12.0	12.0	93.0	36.0	14	9067200012000	6720
16.0	16.0	108.0	48.0	14	9067200016000	6720

Multi-flute plunging router











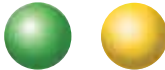







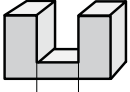

TECH-LINE MATERIAL SPECIFIC





Tool Selection Guide

Steel		<p>Free Machining & Low Carbon Steels - up to 28 HRc Examples: 1006, 1008, 1015, 1018, 1020, 1022, 1025, 1117, 1140, 1141, 11L08, 11L14, 1213, 12L13, 12L14, 1215, 1330</p> <p>Medium Carbon & High Carbon Steels, Alloy Steels & Easy to Machine Tool Steels - up to 38 HRc Examples: 1030, 1035, 1040, 1045, 1050, 1052, 1055, 1060, 1085, 1095, 1541, 1551, 9255, 2515, 3135, 3415, 4130, 4137, 4140, 4150, 4320, 4340, 4520, 5015, 5115, 5120, 5132, 5140, 5155, 6150, 8620, 9262, 9840, 52100, O1, O2, O6, S2, W1 to W310</p>
Stainless Steel		<p>Stainless Steel - Easy to Machine up to 28 HRc Examples: 430F, 301, 303, 410, 416 Annealed, 420F, 430, 430F</p> <p>Stainless Steel - Moderately Difficult up to 28 HRc Examples: 301, 302, 303 High Tensile, 304, 304L, 305, 420, 15-5PH, 17-4PH, 17-7PH</p> <p>Stainless Steel - Difficult to Machine over 28 HRc Examples: 302B, 304B, 309, 310, 316, 316B, 316L, 316Ti, 317, 317L, 321, PH13-8MO, Nitronic</p>
Tool Steel & High Tensile Steels		<p>Tool Steels & Die Steels up to 44 HRc Examples: O7, M1, M2, M3, M4, M7, T1, T2, T4, T5, T8, T15, A2, A3, A6, A7, H10, H11, H12, H13, H19, H21, L3, L6, L7, P2, P20, S1, S5, S7, 52100, A 128, D2, D3, D4, D5, D7</p> <p>Hardened Steels up to 54 HRc Examples: Carbon and Alloy Steels, Tool & Die Steels</p> <p>Hardened Steels up to 60 HRc Examples: Carbon and Alloy Steels, Tool & Die Steels</p>
Cast Iron		<p>Cast Iron - Gray CG up to 180 HB 30 Examples: ASTM A48, CLASS 20, 25, 30, 35, SAE J431C, GRADES G1800, G3000, G3500, GG 10, 15, 20, 25, 30, 35, 40</p> <p>Cast Iron - Ductile & Malleable CGI above 180 HB 30 Examples: 60-40-18, 65-45-12, D4018, D4512, D5506, 32510, 35108, M3210, M4504, M5503, 250, 300, 350, 400, 450</p>
Aluminum		<p>Aluminum, Al-wrought alloys, Al-alloys Examples: 2024, 6061, 7075, 1050, 6351, 5005, 2017, 7075</p> <p>Aluminum-cast alloys Examples: High Silicon - A380, A390, Castings, 3.2131 G-AISI5Cu1, 3.2153 G-AISI7Cu3, 3.2573 G-AISI9, 3.2581 G-AISI12, 3.2583 G-AISI12Cu, - G-AISI12CuNiMg</p>
Titanium & Nickel Alloys		<p>High-Temperature Alloys Examples: Nimonic, Inconel, Monel, Hastelloy</p> <p>Titanium Alloys Examples: 6Al-4V, 5Al-2.5 Sn, 6Al-2Sn-4Zr-6Mo, 3Al-8V-6Cr4Mo-4Zr, 10V-2Fe-3Al, 13V-11Cr-3Al</p>
Hardened Materials		<p>Hardened Steels up to 54 HRc Examples: Carbon and Alloy Steels, Tool & Die Steels</p> <p>Hardened Steels up to 60 HRc Examples: Carbon and Alloy Steels, Tool & Die Steels</p>

Application			Slot drilling  1 x d	Roughing  0.3-0.8 x d	Finishing  > 0.1 x d	Super finishing  0.1 x d
Material/ Application group	Hardness tensile strength	Example material	Rigid conditions:  - good cooling - short-chipping	Unstable conditions:  - standard cooling - medium- to long-chipping	Finishing: 	
Steel 	up to 28 HRc	1045 / 5115	Aero-Tech Series #3713 Page 85	Rough-Tech 48 Series #3188 Page 99	Finish-Tech 50 Series #3179 Page 103	
	above 28 HRc	4140	Aero-Tech Series #3173 Page 85	Aero-Rough 48 Series #3097 Page 95		
Stainless steel 	up to 28 HRc	304 / 303	Aero-Tech Series #3713 Page 85	Aero-Rough 48 Series #3097 Page 95		
	above 28 HRc	316Ti	Aero-Tech Series #3173 Page 85	Aero-Rough 48 Series #3097 Page 95		
Cast iron 	up to 180 HB 30	Gray Cast	Aero-Tech Series #3713 Page 85	Aero-Rough 48 Series #3097 Page 95		
	above 180 HB 30	GGG / GGT / GGv ductile	Aero-Tech Series #3173 Page 85	Aero-Rough 56 Series #3098 Page 96		
Aluminium 	up to 3% Si	Wrought Alloys	Alumi-Tech Series #3174 Page 89	Rough-Tech ALU Series #3184 Page 93	Alumi-Tech Series #3177 Page 91	
	above 3% Si	Cast Alloys	Aero-Tech Series #3713 Page 85	Rough-Tech ALU Series #3184 Page 93	Alumi-Tech Series #3177 Page 91	
Ti- special alloys 	Ti-basis	TiAl6V4 Inconel 625	Aero-Tech Series #3713 Page 85	Aero-Rough 56 Series #3098 Page 96	Finish-Tech 50 Series #3179 Page 103	
	Ni-basis	Inconel 728	Aero-Tech Series #3713 Page 85	Aero-Rough 48 Series #3098 Page 96		
Hardened steel H	up to 52 HRC	H11	Aero-Tech Series #3713 Page 85	Aero-Rough 56 Series #3098 Page 96		
	above 52 HRC	D2	—	Rough-Tech 56 Series #3189 Page 101		

Type	Helix angle	Number of teeth	Length	Tool description	Tool material Surface finish	Gurthing no.		Unit	Diameter Range	Page
						HA	HB			
GH 100 U / AERO-TECH end mills (3-fluted)					carbide					
NH	45°	3			FIREX®	3086		Inch	1/16 - 1/2	85
NH	45°	3			FIREX®	3540	3729	Metric	3 - 20	86
NH	45°	3			Bright	3172		Inch	1/8 - 1	85
NH	45°	3			FIREX®	3173		Inch	1/8 - 1	85
NH	45°	3			Bright	3203		Metric	2 - 20	86
NH	45°	3			FIREX®	3741		Metric	2 - 20	86
ALUMI-TECH end mills (2-fluted) for aluminum					carbide					
W	45°	2			Bright	3310	3126	Metric	3 - 20	90
W	45°	2			Bright	3309	3059	Metric	3 - 20	90
W	45°	2			Bright	3174		Inch	1/8 - 1	89
W	45°	2			Super-A™	3874		Inch	1/8 - 1	89
W	45°	2			Bright	3358		Metric	5 - 16	90
W	45°	2			Bright	3175		Inch	1/4 - 5/8	89
W	45°	2			Super-A™	3875		Inch	1/4 - 5/8	89

Type	Helix angle	Number of teeth	Length	Tool description	Tool material Surface finish	Gurthing no.	Gurthing no.	Unit	Diameter Range	Page
						HA	HB			
GA 200 A / ALUMI-TECH LR end mills (3-fluted) with corner radius					carbide					
W	45°	3			Bright	3177		Inch	1/4 - 3/4	91
W	45°	3			Super-A™	3877		Inch	1/4 - 3/4	91
W	45°	3			Bright	3367		Metric	6 - 20	91
GS 100 A / ROUGH-TECH ALU end mills, coarse tooth					carbide					
WR	30°	3			Bright	3184		Inch	1/4 - 1	93
WR	30°	3			Super-A™	3884		Inch	1/4 - 1	93
WR	30°	3			Bright		3127	Metric	6 - 25	93
WR	30°	3			Bright		3364	Metric	6 - 20	93
RS 100 U / AERO-ROUGH 48 end mills					carbide					
NF	30°	4/5			FIREX®	3097		Inch	1/4 - 1	95
NF	30°	4/5			FIREX®	3887	3888	Metric	6 - 25	95
RS 100 F / AERO-ROUGH 56 end mills					carbide					
NF	45°	5/6			FIREX®	3098		Inch	1/4 - 1	96
NF	45°	5/6			FIREX®	3889	3890	Metric	6 - 25	96

Type	Helix angle	Number of teeth	Length	Tool description	Tool material Surface finish	Gurthing no.	Gurthing no.	Unit	Diameter Range	Page
						HA	HB			
GS 100 U / ROUGH-TECH 48 end mills, fine tooth					carbide					
NRf	30°	4/5			Bright	3186		Inch	1/4 - 1	99
NRf	30°	4/5			FIREX®	3188		Inch	1/4 - 1	99
NRf	30°	4/5			Super-A™	3886		Inch	1/4 - 1	99
NRf	30°	4/5			Bright		3204	Metric	6 - 25	99
NRf	30°	4/5			FIREX®		3723	Metric	6 - 25	99
NRf	30°	4			FIREX®		3365	Metric	6 - 20	99
GS 100 H / ROUGH-TECH 56 end mills, fine tooth					carbide					
HR	20°	4			FIREX®	3189		Inch	1/4 - 3/4	101
HR	20°	4			FIREX®		3682	Metric	6 - 20	101
HR	20°	4			FIREX®	3190		Inch	1/4 - 3/4	101
GH 100 H / FINISH-TECH 62 multi-flute end mills					carbide					
H	55°	6/8			FIREX®	3182		Inch	1/4 - 3/4	107
H	55°	6/8			FIREX®	3715		Metric	3 - 20	108
H	55°	6/8			FIREX®	3183		Inch	1/4 - 3/4	107
H	55°	6/8			FIREX®	3716		Metric	3 - 20	108

Type	Helix angle	Number of teeth	Length	Tool description	Tool material Surface finish	Gurhing no.	Gurhing no.	Unit	Diameter Range	Page
						HA	HB			
GH 100 U / FINISH TECH 50					carbide					
NH	45°	6-10			Bright	3178		Inch	1/4 - 1	103
NH	45°	6-10			FIREX®	3179		Inch	1/4 - 1	103
NH	45°	6-10			Bright	3311	3019	Metric	3 - 25	105
NH	45°	6-10			FIREX®	3689	3047	Metric	3 - 20	104
NH	45°	6/8			FIREX®	3091		Inch	1/4 - 3/4	103
NH	45°	6/8			nano-Si®	3084	3084	Inch	1/4 - 3/4	106
NH	45°	6/8			Bright	3112		Metric	6 - 20	105
NH	45°	6/8			FIREX®	3563		Metric	6 - 20	104
NH	45°	6/8			Bright	3180		Inch	1/4 - 3/4	103
NH	45°	6/8			FIREX®	3181		Inch	1/4 - 3/4	103
NH	45°	6/8			Bright	3312	3313	Metric	6 - 20	105
NH	45°	6/8			FIREX®	3691	3693	Metric	6 - 20	104
GF 500 T HSC-profile cutters with Torus form					carbide					
N	30°	2			TiAlN	3856		Metric	2 - 12	117
N	30°	2			TiAlN	3859		Metric	2 - 12	117
N	30°	2			TiAlN	3865		Metric	6 - 12	117
N	30°	2			TiAlN	3863		Metric	4 - 12	117
N	30°	2			TiAlN	3860		Metric	2 - 8	117

Type	Helix angle	Number of teeth	Length	Tool description	Tool material Surface finish	Gurthing no. HA	Gurthing no. HB	Unit	Diameter Range	Page
GF 500 B HSC-Ball nose profile cutters					carbide					
N	30°	2			TiAlN	3848		Metric	2 - 12	116
N	30°	2			TiAlN	3854		Metric	6 - 12	116
N	30°	2			TiAlN	3855		Metric	6 - 12	116
N	30°	2			TiAlN	3866		Metric	4 - 12	116
N	30°	2			TiAlN	3849		Metric	2 - 12	116
N	30°	2			TiAlN	3853		Metric	2 - 8	116
GF 300 T / TRACE-TECH hard profile cutters with Torus grind					carbide					
H	30°	4			FIREX®	3192		Inch	3/16 - 5/8	113
H	30°	4			FIREX®	3362		Metric	6 - 16	113
GF 300 B / TRACE-TECH ball nose hard profile cutters					carbide					
H	30°	2			FIREX®	3101		Inch	1/8 - 1/2	111
H	30°	2			FIREX®	3359		Metric	.5 - 16	112
H	30°	2			FIREX®	3191		Inch	1/8 - 5/8	111
H	30°	2			FIREX®	3360		Metric	3 - 16	112

GUHRING

Reconditioning Facilities

Brookfield Distribution Center and Reconditioning Facility

1445 Commerce Avenue
Brookfield, WI 53045
Tel (262) 784-6730 (800) 776-6170
Fax (262) 784-9096



California Distribution Center and Reconditioning Facility

15581 Computer Ln
Huntington Beach, CA 92649
Tel (714) 841-3582
Fax (800) 877-7202



Connecticut Reconditioning Facility

121 W Dudley Town Rd.
Bloomfield, CT 06002
Tel (860) 216-5948
Fax (860) 519-5819



Michigan Manufacturing and Reconditioning Facility

29550 W.K. Smith Rd. Suite B
New Hudson, MI 48165
Tel (248) 486-3783
Fax (248) 486-0046



All four Guhring Reconditioning Facilities have coating capabilities as well.

AERO-TECH / GH 100 U

high-performance end mills

The new design Guhring GH 100 U end mills offer the ultimate pre-requisite for a cost-efficient, optimal machining of general steels, high-alloyed steels, CrNi steels as well as stainless steels and titanium-alloys up to 50 HRC.

All GH 100 U end mills excel thanks to their micro-corner protection combined with a reinforced and corrected minor cutting edge. This design considerably reduces the wear at the cutting edges allowing a higher feed rate as well as improved tool life.

Micro-corner protection and corrected reinforced cutting edge = optimal stability



GH 100 U end mills (3-fluted) excel further thanks to their optimized flute geometry, achieving ultimate machining efficiency especially for slot milling and roughing operations. Paired with a very high spiral, optimal chip evacuation is achieved while reducing vibration. The advantages:

- reduced wear
- high feed rates possible
- optimal chip evacuation
- can be applied for roughing and finishing



Material	Alloyed Steel		Tool Steel		Cast iron		Stainless steel		Aluminium		Ti-special alloys		H	
	up to 28Hrc	over 28 Hrc	up to 180 HB 30	over 180 HB 30	up to 28 HRC	over 28 HRC	up to 3% Si	over 3% Si	Ti-based	Ni-based	up to 52 HRC	over 52 HRC		
Aero-Tech	○	●	○	●	○	●	○	●	○	○	○	○		
Alumi-Tech	○							●	●					
Rough-Tech ALU	○							●	●					
Aero-Rough 48	●	●	●	○	●	○	○	○	○	○	○	○		
Aero-Rough 56	○	●	●	●	○	○				●	○	●	○	
Rough-Tech 48	●	●	●	○	●	○	○	○	○	○	○	○		
Rough-Tech 56	○	●	●	●					○	●	●	○		
Finish-Tech 50	○	●	●	●	●	●	○	●	●	●	●	●		
Finish-Tech 62			○	●						○	●	●		
GF 500	○	●	●	●	○	○			●	●	●	●		
GF 300		○	○	●					○	○	●	●		
Uni-Pro (all)	●	○	●	○	○	●	●	○	○	●				

● = optimal suitability

○ = limited suitability

AERO-TECH GH100 U

3-flute

Includes Series

INCH

3086

3172

3173

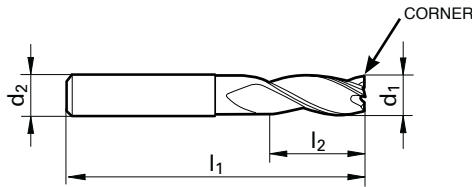

TYPE

NH

HELIX ANGLE

45°

NUMBER of TEETH

3

d₁ tolerance h10
d₂ tolerance h6
See table on page 150

Diameter	Shank Diameter	OAL	LOC	Corner	HA		HA	
					EDP No. FIREX® Coated	Series Number	EDP No. Bright Finish	Series Number
(d1) Frac	(d2) Frac	(l1) Frac	(l2) Frac	Chamfer Inch				
1/16	1/8	1 1/2	1/8	0.001	9030860015900	3086		
1/8	1/8	1 1/2	3/8	0.002	9031730031700	3173	9031720031700	3172
1/8	1/8	2	1/4	0.002	9030860031700	3086		
3/16	3/16	2	3/8	0.002	9030860047600	3086		
3/16	3/16	2	5/8	0.002	9031730047600	3173	9031720047600	3172
1/4	1/4	2	1/2	0.004	9030860063500	3086		
1/4	1/4	2 1/2	3/4	0.004	9031730063500	3173	9031720063500	3172
5/16	5/16	2	1/2	0.004	9030860079400	3086		
5/16	5/16	2 1/2	13/16	0.004	9031730079400	3173	9031720079400	3172
3/8	3/8	2	5/8	0.004	9030860095200	3086		
3/8	3/8	2 1/2	1	0.004	9031730095200	3173	9031720095200	3172
7/16	7/16	2 1/2	5/8	0.006	9030860111100	3086		
7/16	7/16	2 3/4	1	0.006	9031730111100	3173	9031720111100	3172
1/2	1/2	2 1/2	5/8	0.006	9030860127000	3086		
1/2	1/2	3	1	0.006	9031730127000	3173	9031720127000	3172
5/8	5/8	3 1/2	1 1/4	0.006	9031730158700	3173	9031720158700	3172
3/4	3/4	4	1 1/2	0.006	9031730190500	3173	9031720190500	3172
1	1	4	1 1/2	0.012	9031730254000	3173	9031720254000	3172

AERO-TECH GH100 U

3-flute

Includes Series

METRIC
3203
3540
3729
3741

TYPE	NH
HELIX ANGLE	45°
NUMBER of TEETH	3

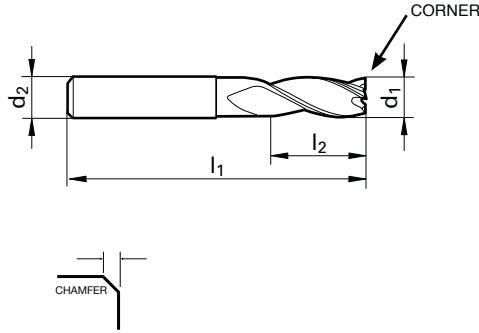

d_1 tolerance h10
 d_2 tolerance h6
 See table on page 150

Diameter	Shank Diameter	OAL	LOC	Chamfer mm	HA		HB		HA	
					EDP No. FIREX® Coated	Series Number	EDP No. FIREX® Coated	Series Number	EDP No. Bright Finish	Series Number
2.0	2.0	32	6	0.05	9037410020000	3741			9032030020000	3203
2.5	2.5	32	7	0.05	9037410025000	3741			9032030025000	3203
3.0	3.0	38	7	0.05	9037410030000	3741			9032030030000	3203
3.0	6.0	50	4	0.05	9035400030000	3540	9037290030000	3729		
3.5	3.5	50	7	0.05	9037410035000	3741			9032030035000	3203
4.0	4.0	50	8	0.05	9037410040000	3741			9032030040000	3203
4.0	6.0	54	5	0.05	9035400040000	3540	9037290040000	3729		
4.5	4.5	50	8	0.05	9037410045000	3741			9032030045000	3203
5.0	5.0	50	10	0.05	9037410050000	3741			9032030050000	3203
5.0	6.0	54	6	0.05	9035400050000	3540	9037290050000	3729		
5.5	5.5	57	10	0.05	9037410055000	3741			9032030055000	3203
6.0	6.0	54	7	0.05	9035400060000	3540	9037290060000	3729		
6.0	6.0	57	10	0.05	9037410060000	3741			9032030060000	3203
6.5	6.5	60	13	0.10	9037410065000	3741			9032030065000	3203
7.0	8.0	58	8	0.10	9035400070000	3540	9037290070000	3729		
7.0	7.0	60	13	0.10	9037410070000	3741			9032030070000	3203
7.5	7.5	63	16	0.10	9037410075000	3741			9032030075000	3203
8.0	8.0	58	9	0.10	9035400080000	3540	9037290080000	3729		
8.0	8.0	63	16	0.10	9037410080000	3741			9032030080000	3203
8.5	8.5	67	16	0.10	9037410085000	3741			9032030085000	3203
9.0	10.0	66	10	0.10	9035400090000	3540	9037290090000	3729		
9.0	9.0	67	16	0.10	9037410090000	3741			9032030090000	3203
9.5	9.5	72	19	0.10	9037410095000	3741			9032030095000	3203
10.0	10.0	66	11	0.10	9035400100000	3540	9037290100000	3729		
10.0	10.0	72	19	0.10	9037410100000	3741			9032030100000	3203
11.0	11.0	83	22	0.15	9037410110000	3741			9032030110000	3203
12.0	12.0	73	12	0.15	9035400120000	3540	9037290120000	3729		
12.0	12.0	83	22	0.15	9037410120000	3741			9032030120000	3203
13.0	13.0	83	22	0.15	9037410130000	3741			9032030130000	3203
14.0	14.0	75	14	0.15	9035400140000	3540	9037290140000	3729		
14.0	14.0	83	22	0.15	9037410140000	3741			9032030140000	3203
15.0	15.0	92	26	0.15	9037410150000	3741			9032030150000	3203
16.0	16.0	82	16	0.15	9035400160000	3540	9037290160000	3729		
16.0	16.0	92	26	0.15	9037410160000	3741			9032030160000	3203
18.0	18.0	84	18	0.15	9035400180000	3540	9037290180000	3729		
18.0	18.0	92	26	0.15	9037410180000	3741			9032030180000	3203
20.0	20.0	92	20	0.15	9035400200000	3540	9037290200000	3729		
20.0	20.0	104	32	0.15	9037410200000	3741			9032030200000	3203

GUHRING

E-Learning

Product Info

Videos

How To's

Product Demos

Tutorials

Catalog Info

Everything you need to know about Guhring products,
and more.

www.guhring.com/ELearning/

High metal removal end mills ALUMI-TECH GA 200 A: The specialist for machining aluminium

This innovative tool was developed specifically for the machining of integrated aluminum components and is suitable for roughing and slot milling as well as finishing operations.



Special features:

- radial coolant exit (64° angle) for optimal chip evacuation (series #3367)
- radius geometry with continuous helix-radius-correction
- reduced neck ground for collision reduction

Seamless radius area provides high form and contour accuracy

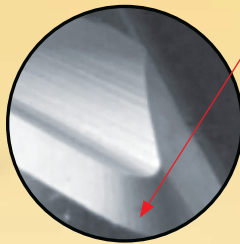

Material	Alloyed Steel	Tool Steel	Cast iron	Stainless steel	Aluminium	Ti-special alloys	H					
	up to 28HRC	over 28 HRC	up to 180 HB 30	over 180 HB 30	up to 28 HRC	over 28 HRC	up to 3% Si	over 3% Si	Ti-based	Ni-based	up to 52 HRC	over 52 HRC
Aero-Tech	○	●	○	●	○	●	○	○	○	○	○	○
Alumi-Tech	○					●	●					
Rough-Tech ALU	○					●	●					
Aero-Rough 48	●	●	●	○	●	○	○	○	○	○		
Aero-Rough 56	○	●	●	●	○	○			●	○	●	○
Rough-Tech 48	●	●	●	○	●	○	○	○	○	○		
Rough-Tech 56	○	●	●	●					○	●	●	○
Finish-Tech 50	○	●	●	●	●	○	●	●	●	●	●	
Finish-Tech 62			○	●					○	●	●	●
GF 500	○	●	●	●	○	○			●	●	●	
GF 300		○	○	●					○	○	●	●
Uni-Pro (all)	●	○	●	○	○	●	○	○	○	●		

● = optimal suitability

○ = limited suitability

ALUMI-TECH GA 200 A

2-flute

Includes Series

INCH
3174
3175
3874
3875



TYPE

W

HELIX ANGLE

45°

NUMBER of TEETH

2

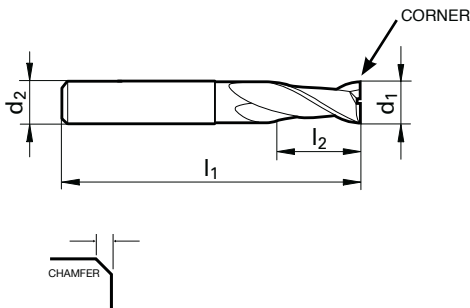

d₁ tolerance h10
d₂ tolerance h6
See table on page 150

Diameter	Shank Diameter	OAL	LOC	Corner		HA	HA		
(d1) Frac	(d2) Frac	(l1) Frac	(l2) Frac	Chamfer Inch	Flutes	EDP No. Bright Finish	Series Number	EDP No. Super-A	Series Number
1/8	1/8	1 1/2	7/16	0.001	2	9031740031700	3174	9038740031700	3874
3/16	3/16	2	9/16	0.001	2	9031740047600	3174	9038740047600	3874
1/4	1/4	2 1/2	3/4	0.002	2	9031740063500	3174	9038740063500	3874
1/4	1/4	3	1 1/8	0.002	2	9031750063500	3175	9038750063500	3875
5/16	5/16	2 1/2	13/16	0.002	2	9031740079400	3174	9038740079400	3874
3/8	3/8	2 1/2	7/8	0.002	2	9031740095200	3174	9038740095200	3874
3/8	3/8	3	1 1/8	0.002	2	9031750095200	3175	9038750095200	3875
7/16	7/16	2 3/4	1	0.004	2	9031740111100	3174	9038740111100	3874
1/2	1/2	3	1	0.004	2	9031740127000	3174	9038740127000	3874
1/2	1/2	4 1/2	2	0.004	2	9031750127000	3175	9038750127000	3875
9/16	9/16	3 1/2	1 1/8	0.004	2	9031740142900	3174	9038740142900	3874
5/8	5/8	3 1/2	1 1/4	0.004	2	9031740158700	3174	9038740158700	3874
5/8	5/8	5	2 1/4	0.004	2	9031750158700	3175	9038750158700	3875
3/4	3/4	4	1 1/2	0.004	2	9031740190500	3174	9038740190500	3874
1	1	4	1 1/2	0.008	2	9031740254000	3174	9038740254000	3874

ALUMI-TECH GA 200 A

Bright Finish, 2-flute

Includes Series

METRIC
3059
3126
3309
3310
3358



TYPE	W
HELIX ANGLE	45°
NUMBER of TEETH	2

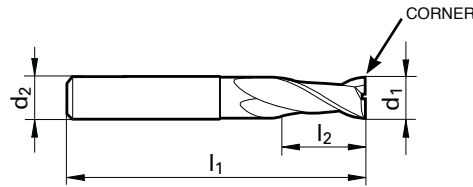

d₁ tolerance h10
d₂ tolerance h6
See table on page 150



Diameter	Shank Diameter	OAL	LOC	Corner	Flutes	HA		HB	
						EDP No.	Series Number	EDP No.	Series Number
3.0	6.0	50	4	0.03	2	9033100030000	3310	9031260030000	3126
3.0	6.0	57	7	0.03	2	9033090030000	3309	9030590030000	3059
4.0	6.0	54	5	0.03	2	9033100040000	3310	9031260040000	3126
4.0	6.0	57	8	0.03	2	9033090040000	3309	9030590040000	3059
5.0	6.0	54	6	0.03	2	9033100050000	3310	9031260050000	3126
5.0	6.0	57	10	0.03	2	9033090050000	3309	9030590050000	3059
5.0	5.0	75	30	0.03	2	9033580050000	3358		
6.0	6.0	54	7	0.03	2	9033100060000	3310	9031260060000	3126
6.0	6.0	57	10	0.03	2	9033090060000	3309	9030590060000	3059
6.0	6.0	75	30	0.03	2	9033580060000	3358		
8.0	8.0	58	9	0.05	2	9033100080000	3310	9031260080000	3126
8.0	8.0	63	16	0.05	2	9033090080000	3309	9030590080000	3059
8.0	8.0	100	40	0.05	2	9033580080000	3358		
10.0	10.0	66	11	0.05	2	9033100100000	3310	9031260100000	3126
10.0	10.0	72	19	0.05	2	9033090100000	3309	9030590100000	3059
10.0	10.0	100	40	0.05	2	9033580100000	3358		
12.0	12.0	73	12	0.10	2	9033100120000	3310	9031260120000	3126
12.0	12.0	83	22	0.10	2	9033090120000	3309	9030590120000	3059
12.0	12.0	150	45	0.10	2	9033580120000	3358		
14.0	14.0	75	14	0.10	2	9033100140000	3310	9031260140000	3126
14.0	14.0	83	22	0.10	2	9033090140000	3309	9030590140000	3059
16.0	16.0	82	16	0.10	2	9033100160000	3310	9031260160000	3126
16.0	16.0	92	26	0.10	2	9033090160000	3309	9030590160000	3059
16.0	16.0	150	65	0.10	2	9033580160000	3358		
18.0	18.0	84	18	0.10	2	9033100180000	3310	9031260180000	3126
18.0	18.0	92	26	0.10	2	9033090180000	3309	9030590180000	3059
20.0	20.0	92	20	0.10	2	9033100200000	3310	9031260200000	3126
20.0	20.0	104	32	0.10	2	9033090200000	3309	9030590200000	3059

ALUMI-TECH GA 200 A

3-flute

Includes Series

INCH

3177

3877



TYPE **W**

HELIX ANGLE **45°**

NUMBER of TEETH **3**

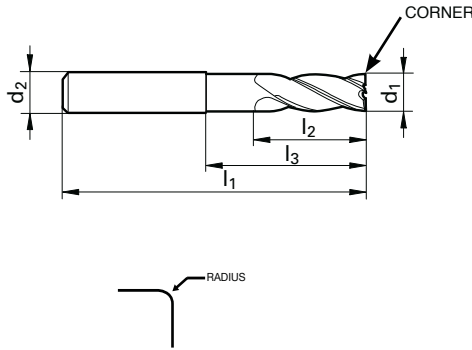

d₁ tolerance h10
d₂ tolerance h6
See table on page 150

Diameter	Shank Diameter	OAL	LOC	Reach	Corner		HA	HA		
(d1) Frac	(d2) Frac	(l1) Frac	(l2) Frac	*(l3) Inch	Radius Inch	Flutes	EDP No. Bright Finish	Series Number	EDP No. Super-A	Series Number
1/4	1/4	3	3/8	1 1/2	0.010	3	9031770063500	3177	9038770063500	3877
5/16	5/16	3	7/16	1 1/2	0.013	3	9031770079400	3177	9038770079400	3877
3/8	3/8	3	9/16	1 1/2	0.015	3	9031770095200	3177	9038770095200	3877
1/2	1/2	4 1/2	3/4	2 3/4	0.020	3	9031770127000	3177	9038770127000	3877
5/8	5/8	5	7/8	3	0.025	3	9031770158700	3177	9038770158700	3877
3/4	3/4	5	1	3	0.030	3	9031770190500	3177	9038770190500	3877

* Indicates reduced neck style

METRIC

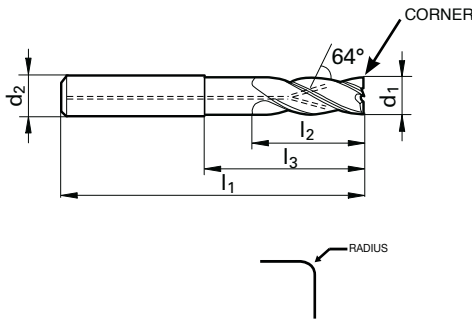

Includes Series

METRIC

3367

*Coolant through

Diameter	Shank Diameter	OAL	LOC	Reach	Corner		HA
(d1) mm	(d2) mm	(l1) mm	(l2) mm	*(l3) mm	Radius mm	Flutes	EDP No. Series Number
6.0	6.0	57	10	21	1.0	3	9033670060000 3367
8.0	8.0	63	16	27	1.0	3	9033670080000 3367
10.0	10.0	72	19	32	1.5	3	9033670100000 3367
12.0	12.0	83	22	38	1.5	3	9033670120000 3367
16.0	16.0	92	26	44	2.0	3	9033670160000 3367
20.0	20.0	104	32	54	2.5	3	9033670200000 3367

* Indicates reduced neck style

ROUGH-TECH ALU / GS 100 A roughing cutters for aluminum, alloys and soft steel

GS 100 roughing cutters excel primarily thanks to their general purpose application possibilities enabling almost any combination of cutting depth (DOC) and cutting width (WOC). In comparison to roughing/finishing cutters with a flat knuckle-type geometry, the considerably lower power requirement ensures a reliable and economical machining process especially with less powerful machines. Thanks to its round knuckle-type geometry with a staggered pitch angle (see illustration) the feed engagement is spread across the full length of the cutting edge even with less rigid workpiece clamping conditions or long tool neck lengths. In spite of a lower tooth feed rate compared to flat knuckle-types a high rate of metal removal is achieved.



GS 100 A: special geometry for aluminum:

- The 3-flute, 30° RH helix GS 100 A is suitable for the machining of aluminum, aluminum-alloys and other soft materials up to 700 N/mm².

Advantages at a glance:

- reduced power requirement and cutting pressure
- suitable for less powerful and less stable machines
- suitable for less favorable workpiece and tool clamping conditions
- high metal removal rate thanks to the utilization of the complete cutting edge length

In comparison with conventional tools, GS 100 A roughing cutters with internal cooling excel with considerably longer tool life and higher feed rates as well as increased feed engagement widths and depths. Guhring milling cutters with radial coolant exits at 64° provide particular protection to the sensitive corners. The specifically aimed coolant exits completely prevent built-up edges and ensure complete chip evacuation, especially with deep pockets and channels.



Material	Alloyed Steel	Tool Steel	Cast iron	Stainless steel	Aluminium	Ti-special alloys	H					
Hardness tensile strength	up to 28HRC	over 28 HRC	up to 180 HB 30	over 180 HB 30	up to 28 HRC	over 28 HRC	up to 3% Si	over 3% Si	Ti-based	Ni-based	up to 52 HRC	over 52 HRC
Rough-Tech ALU	○					●	●					

● = optimal suitability

○ = limited suitability

FRACTIONAL

ROUGH-TECH ALU GS100 A

Bright Finish, rougher, 3-flute

Includes Series

INCH

3184

3884



TYPE **WR**

HELIX ANGLE **30°**

NUMBER of TEETH **3**

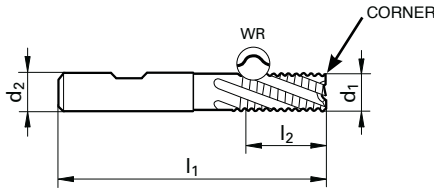

d_1 tolerance h10
 d_2 tolerance h6
 See table on page 150

Diameter	Shank Diameter	OAL	LOC	Corner		HA		HA	
(d1) Frac	(d2) Frac	(l1) Frac	(l2) Frac	Chamfer Inch	Flutes	EDP No. Bright Finish	Series Number	EDP No. Super-A	Series Number
1/4	1/4	2 1/2	3/4	0.012	3	9031840063500	3184	9038840063500	3884
5/16	5/16	2 1/2	3/4	0.012	3	9031840079400	3184	9038840079400	3884
3/8	3/8	2 1/2	7/8	0.012	3	9031840095200	3184	9038840095200	3884
1/2	1/2	3	1	0.020	3	9031840127000	3184	9038840127000	3884
5/8	5/8	3 1/2	1 1/4	0.020	3	9031840158700	3184	9038840158700	3884
3/4	3/4	4	1 5/8	0.020	3	9031840190500	3184	9038840190500	3884
1	1	4	1 3/4	0.031	3	9031840254000	3184	9038840254000	3884

METRIC

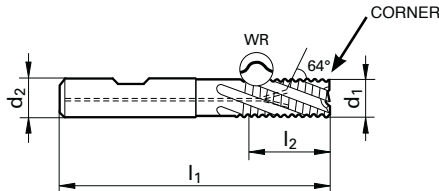

Includes Series

METRIC

3127

*3364

*Coolant through

Diameter	Shank Diameter	OAL	LOC	Corner		HB		HB	
(d1) Frac	(d2) Frac	(l1) Frac	(l2) Frac	Chamfer Inch	Flutes	EDP No.	Series Number	EDP No. Coolant Through	Series Number
6.0	6.0	57	10	0.30	3	9031270060000	3127	9033640060000	3364
8.0	8.0	63	16	0.30	3	9031270080000	3127	9033640080000	3364
10.0	10.0	72	19	0.30	3	9031270100000	3127	9033640100000	3364
12.0	12.0	83	22	0.50	3	9031270120000	3127	9033640120000	3364
14.0	14.0	83	22	0.50	3	9031270140000	3127		
16.0	16.0	92	26	0.50	3	9031270160000	3127	9033640160000	3364
18.0	18.0	92	26	0.50	3	9031270180000	3127		
20.0	20.0	104	32	0.50	3	9031270200000	3127	9033640200000	3364
25.0	25.0	121	45	0.80	3	9031270250000	3127		

AERO-ROUGH / RS 100 U/F - Roughing geometry for optimal efficiency



RS 100 high-performance roughing cutters benefit from a completely new roughing geometry, considerably reducing surface finish wear thanks to its unequal spacing. The result is a drastic increase in tool life compared to conventional round knuckle-type geometries and an improvement in the surface finish quality of the workpiece, so that in many applications finishing operations are unnecessary and the machining cost per workpiece is vastly reduced. In addition, the tool excels with a much reduced power requirement in comparison to tools without chip breaking geometry. Two types of RS 100 high-performance roughing cutters are available: The 4-flute, 30° RH spiral RS 100 U is suitable for the machining of all standard steels. With a new 5 to 6 flute geometry and a spiral angle increased to 45°, RS 100 F possesses a considerably increased core diameter and is suitable for roughing/finishing operations with a width of cut up to 0.25 x D in all general purpose steels and tough materials.

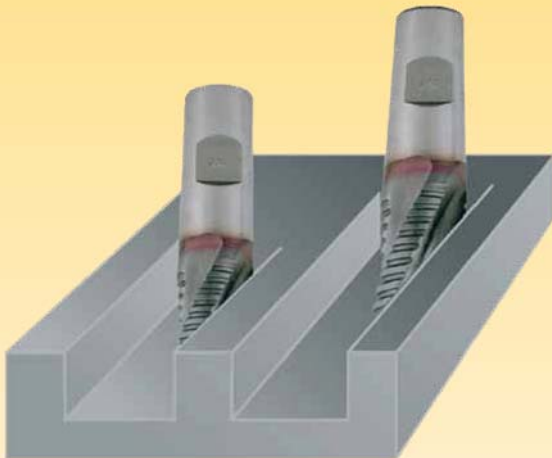

Advantages at a glance:

- increased tool life in comparison to milling cutters with round knuckle-type teeth
- increased feed rate thanks to new edge wear protection
- improved workpiece surface finish
- reduced power requirement compared to smooth cutting milling cutters

Material	Alloyed Steel		Tool Steel		Cast iron		Stainless steel		Aluminium		Ti-special alloys		H	
	up to 28HRC	over 28 HRC	up to 180 HB 30	over 180 HB 30	up to 28 HRC	over 28 HRC	up to 3% Si	over 3% Si	Ti-based	Ni-based	up to 52 HRC	over 52 HRC		
Aero-Rough 48	●	●	●	○	●	○	○	○	○	○	○	○	○	○
Aero-Rough 56	○	●	●	●	○	○				●	○	●	○	○

● = optimal suitability ○ = limited suitability

Comparison overview:

Type	NR round knuckle-type	NF flat knuckle-type (old)	RS 100 U&F (new)
Perform. index	100%	65%	120%
Workpiece Surface finish	Ra = 9-10 µm	Ra = 6-7 µm	Ra = 2-3 µm
Tool life index	100%	100%	140%

FRACTIONAL

AERO-ROUGH 48 RS100 U

FIREX® Coated, rougher, **4/5-flute**

Includes Series

INCH

3097



TYPE

NF

HELIX ANGLE

30°

NUMBER of TEETH

4/5

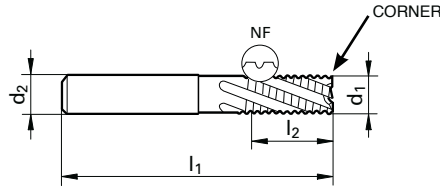

d₁ tolerance h10
d₂ tolerance h6
See table on page 150

Diameter	Shank Diameter	OAL	LOC	Corner		HA	
(d1) Frac	(d2) Frac	(l1) Frac	(l2) Frac	Chamfer Inch	Flutes	EDP No.	Series Number
1/4	1/4	2 1/2	3/4	0.012	4	9030970063500	3097
5/16	5/16	2 1/2	13/16	0.012	4	9030970079400	3097
3/8	3/8	2 1/2	7/8	0.012	4	9030970095200	3097
1/2	1/2	3	1	0.020	4	9030970127000	3097
5/8	5/8	3 1/2	1 1/4	0.020	4	9030970158700	3097
3/4	3/4	4	1 5/8	0.020	4	9030970190500	3097
1	1	4	1 3/4	0.031	5	9030970254000	3097

METRIC

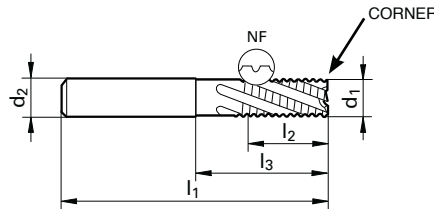

Includes Series

METRIC

3887

3888

Diameter	Shank Diameter	OAL	LOC	Reach	Corner		HA		HB	
(d1) mm	(d2) mm	(l1) mm	(l2) mm	*(l3) mm	Chamfer mm	Flutes	EDP No.	Series Number	EDP No.	Series Number
6.0	6.0	57	13	21	0.30	4	9038870060000	3887	9038880060000	3888
8.0	8.0	63	19	27	0.30	4	9038870080000	3887	9038880080000	3888
10.0	10.0	72	22	32	0.30	4	9038870100000	3887	9038880100000	3888
12.0	12.0	83	26	38	0.50	4	9038870120000	3887	9038880120000	3888
14.0	14.0	83	26	38	0.50	4	9038870140000	3887	9038880140000	3888
16.0	16.0	92	32	44	0.50	4	9038870160000	3887	9038880160000	3888
18.0	18.0	92	32	44	0.50	4	9038870180000	3887	9038880180000	3888
20.0	20.0	104	38	54	0.50	4	9038870200000	3887	9038880200000	3888
25.0	25.0	121	45	65	0.60	5	9038870250000	3887	9038880250000	3888

* Indicates reduced neck style

AERO-ROUGH 56 RS100 F

FIREX® Coated, rougher, 5/6-flute

Includes Series

INCH

3098

TYPE **NF**

HELIX ANGLE **45°**

NUMBER of TEETH **5/6**

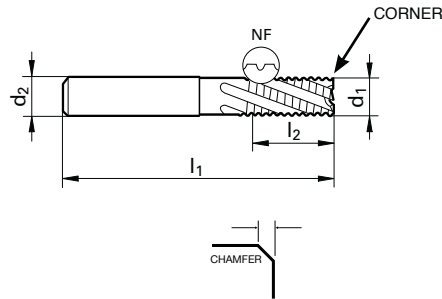

d_1 tolerance h10
 d_2 tolerance h6
 See table on page 150

Diameter	Shank Diameter	OAL	LOC	Corner		HA	
(d1) Frac	(d2) Frac	(l1) Frac	(l2) Frac	Chamfer Inch	Flutes	EDP No.	Series Number
1/4	1/4	2 1/2	3/4	0.012	5	9030980063500	3098
5/16	5/16	2 1/2	13/16	0.012	5	9030980079400	3098
3/8	3/8	2 1/2	7/8	0.012	5	9030980095200	3098
1/2	1/2	3	1	0.020	5	9030980127000	3098
5/8	5/8	3 1/2	1 1/4	0.020	6	9030980158700	3098
3/4	3/4	4	1 5/8	0.020	6	9030980190500	3098
1	1	4	1 3/4	0.031	6	9030980254000	3098

METRIC

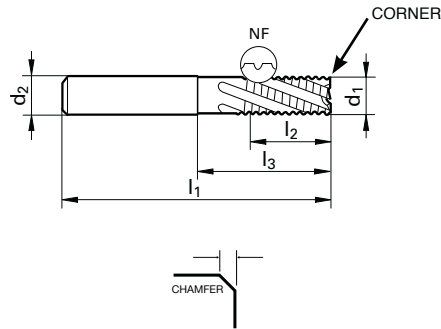

Includes Series

METRIC

3889

3890

Diameter	Shank Diameter	OAL	LOC	Reach			HA		HB	
(d1) mm	(d2) mm	(l1) mm	(l2) mm	*(l3) mm	Chamfer mm	Flutes	EDP No.	Series Number	EDP No.	Series Number
6.0	6.0	57	13	21	0.30	5	9038890060000	3889	9038900060000	3890
8.0	8.0	63	19	27	0.30	5	9038890080000	3889	9038900080000	3890
10.0	10.0	72	22	32	0.30	5	9038890100000	3889	9038900100000	3890
12.0	12.0	83	26	38	0.50	5	9038890120000	3889	9038900120000	3890
14.0	14.0	83	26	38	0.50	5	9038890140000	3889	9038900140000	3890
16.0	16.0	92	32	44	0.50	6	9038890160000	3889	9038900160000	3890
18.0	18.0	92	32	44	0.50	6	9038890180000	3889	9038900180000	3890
20.0	20.0	104	38	54	0.50	6	9038890200000	3889	9038900200000	3890
25.0	25.0	121	45	65	0.60	6	9038890250000	3889	9038900250000	3890

* Indicates reduced neck style

Guhring Navigator:

Guhring Navigator is a step by step program that allows you to find the perfect Guhring tool for your machining task.

Guhring Navigator allows you to specify the material you are cutting and tool features you desire. The ending search result displays the ideal tool(s), speeds and feeds as well as other key information.

Stop flipping through a catalog to find the right tool and let Guhring Navigator do the work for you!

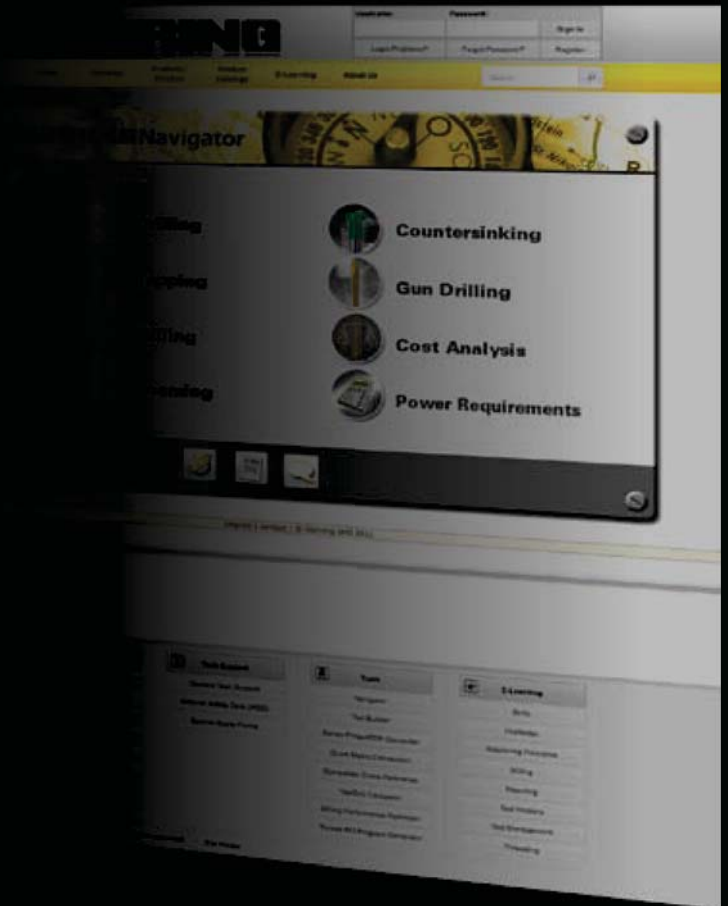

www.GUHRING.com

ROUGH-TECH 48 GS 100 U

roughing cutters for materials < 48 HRC

GS 100 roughing cutters offer extensive general purpose application possibilities. These roughers have a unique round knuckle-type tooth profile which requires less HP than traditional flat knuckle-type end mills.

The unique geometry also has a staggered pitch angle (see illustration), spreading the feed engagement across the full length of the cutting edge and allowing for a high rate of metal removal.

GS 100 U: special geometry for materials < 48 HRC

- The 4-flute GS 100 U with its 30° RH spiral and fine knuckle-type teeth is suitable for the machining of all general steels up to 48 HRC, high-alloyed steels as well as titanium or chrome nickel alloys.

GS 100 H: special geometry for materials < 56 HRC

- The GS 100 F 5- and 6-flute end mill has a 45° right hand spiral with the NF style knuckle design suitable for machining high tensile steels up to 56 HRC hardness.

Advantages at a glance:

- reduced power requirement and cutting pressure
- suitable for less powerful and less stable machines
- suitable for less favorable workpiece and tool clamping conditions
- high metal removal rate thanks to the utilization of the complete cutting edge length

Guhring milling cutters with radial coolant exits at 64° (series #3365) provide particular protection to the sensitive corners. The specifically aimed coolant exits completely prevent built-up edges and ensure complete chip evacuation, especially with deep pockets and channels.



Material	Alloyed Steel	Tool Steel	Cast iron		Stainless steel		Aluminium		Ti-special alloys		H	
	up to 28Hrc	over 28 HRC	up to 180 HB 30	over 180 HB 30	up to 28 HRC	over 28 HRC	up to 3% Si	over 3% Si	Ti-based	Ni-based	up to 52 HRC	over 52 HRC
Aero-Tech	○	●	○	●	○	●	○	●	○	○	○	
Alumi-Tech	○						●	●				
Rough-Tech ALU	○						●	●				
Aero-Rough 48	●	●	●	○	●	○	○	○	○	○		
Aero-Rough 56	○	●	●	●	○	○			●	○	●	○
Rough-Tech 48	●	●	●	○	●	○	○	○	○	○		
Rough-Tech 56	○	●	●	●					○	●	●	○
Finish-Tech 50	○	●	●	●	●	●	○	●	●	●	●	
Finish-Tech 62			○	●						○	●	●
GF 500	○	●	●	●	○	○			●	●	●	
GF 300		○	○	●					○	○	●	●
Uni-Pro (all)	●	○	●	○	○	●	●	○	○	●		

● = optimal suitability

○ = limited suitability

FRACTIONAL

ROUGH-TECH 48 GS100 U

rougner, **4/5-flute**

Includes Series

INCH
3186
3188
3886



TYPE	NRf
HELIX ANGLE	30°
NUMBER of TEETH	4/5

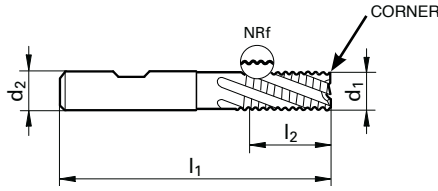

d₁ tolerance h10
d₂ tolerance h6
See table on page 150



Diameter	Shank Diameter	OAL	LOC	Corner		HA		HA		HA	
(d1) Frac	(d2) Frac	(l1) Frac	(l2) Frac	Chamfer Inch	Flutes	EDP No. Bright Finish	Series Number	EDP No. FIREX®	Series Number	EDP No. Super-A	Series Number
1/4	1/4	2 1/2	3/4	0.012	4	9031860063500	3186	9031880063500	3188	9038860063500	3886
5/16	5/16	2 1/2	3/4	0.012	4	9031860079400	3186	9031880079400	3188	9038860079400	3886
3/8	3/8	2 1/2	7/8	0.012	4	9031860095200	3186	9031880095200	3188	9038860095200	3886
1/2	1/2	3	1	0.020	4	9031860127000	3186	9031880127000	3188	9038860127000	3886
5/8	5/8	3 1/2	1 1/4	0.020	4	9031860158700	3186	9031880158700	3188	9038860158700	3886
3/4	3/4	4	1 5/8	0.020	4	9031860190500	3186	9031880190500	3188	9038860190500	3886
1	1	4	1 3/4	0.031	5	9031860254000	3186	9031880254000	3188	9038860254000	3886

METRIC

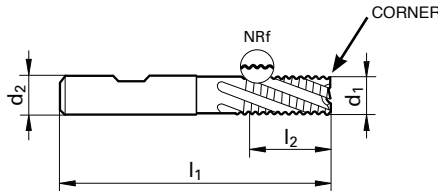

Includes Series

METRIC
3204
3723
*3365

*Coolant through

Diameter	Shank Diameter	OAL	LOC	Corner		HB		HB		HB	
(d1) mm	(d2) mm	(l1) mm	(l2) mm	Chamfer mm	Flutes	EDP No. Bright Finish	Series Number	EDP No. FIREX®	Series Number	EDP No. FIREX® Coolant Through	Series Number
6.0	6.0	57	13	0.30	4	9032040060000	3204	9037230060000	3723	9033650060000	3365
8.0	8.0	63	19	0.30	4	9032040080000	3204	9037230080000	3723	9033650080000	3365
10.0	10.0	72	22	0.30	4	9032040100000	3204	9037230100000	3723	9033650100000	3365
12.0	12.0	83	26	0.50	4	9032040120000	3204	9037230120000	3723	9033650120000	3365
14.0	14.0	83	26	0.50	4	9032040140000	3204	9037230140000	3723		
16.0	16.0	92	32	0.50	4	9032040160000	3204	9037230160000	3723	9033650160000	3365
18.0	18.0	92	32	0.50	4	9032040180000	3204	9037230180000	3723		
20.0	20.0	104	38	0.50	4	9032040200000	3204	9037230200000	3723	9033650200000	3365
25.0	25.0	121	45	0.60	5	9032040250000	3204	9037230250000	3723		

ROUGH-TECH 56 GS 100 H roughing cutters for materials < 54 HRC



GS 100 roughing cutters excel primarily thanks to their general purpose application possibilities enabling almost any combination of cutting depth (DOC) and cutting width (WOC). In comparison to roughing/finishing cutters with a flat knuckle-type geometry, the considerably lower power requirement ensures a reliable and economical machining process especially with less powerful machines.

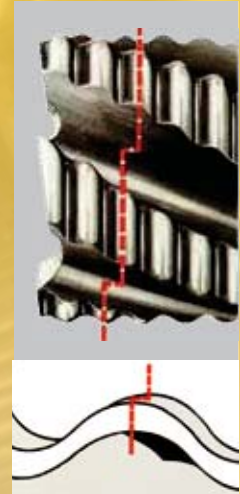

GS 100 H: special geometry for materials < 54 HRC:

- GS 100 H excels in the machining of difficult-to-machine materials over 1000 N/mm², cast iron and grey cast iron as well as hardened materials up to approximately 52 to 54 HRC thanks to its 20° helix and its small rake angle.

Advantages at a glance:

- reduced power requirement and cutting pressure
- suitable for less powerful and less stable machines
- suitable for less favorable workpiece and tool clamping conditions
- high metal removal rate thanks to the utilisation of the complete cutting edge length

Material	Alloyed Steel	Tool Steel	Cast iron		Stainless steel	Aluminium	Ti-special alloys		H			
Hardness tensile strength	up to 28HRC	over 28 HRC	up to 180 HB 30	over 180 HB 30	up to 28 HRC	over 28 HRC	up to 3% Si	over 3% Si	Ti-based	Ni-based	up to 52 HRC	over 52 HRC
Rough-Tech 48	●	●	●	○	●	○	○	○	○	○		
Rough-Tech 56	○	●	●	●					○	●	●	○

● = optimal suitability

○ = limited suitability

FRACTIONAL

ROUGH-TECH 56 GS100 H

FIREX® Coated, rougher, **4-flute**

Includes Series

INCH

3189

3190



TYPE

HR

HELIX ANGLE



NUMBER of TEETH

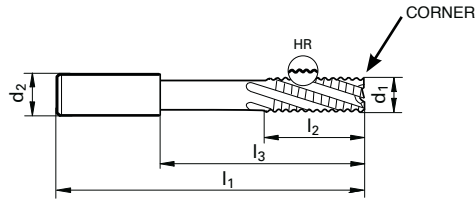

d_1 tolerance h10
 d_2 tolerance h6
 See table on page 150

Diameter	Shank Diameter	OAL	LOC	Reach	Corner		HA	
(d1) Frac	(d2) Frac	(l1) Frac	(l2) Frac	*(l3) Frac	Chamfer Inch	Flutes	EDP No.	Series Number
1/4	1/4	2 1/2	3/4		0.012	4	9031890063500	3189
1/4	1/4	3	3/4	1 1/2	0.012	4	9031900063500	3190
5/16	5/16	2 1/2	3/4		0.012	4	9031890079400	3189
5/16	5/16	3	7/8	1 1/2	0.012	4	9031900079400	3190
3/8	3/8	2 1/2	7/8		0.012	4	9031890095200	3189
3/8	3/8	3	7/8	1 1/2	0.012	4	9031900095200	3190
1/2	1/2	3	1		0.020	4	9031890127000	3189
1/2	1/2	4 1/2	1	2 3/4	0.020	4	9031900127000	3190
5/8	5/8	3 1/2	1 1/4		0.020	4	9031890158700	3189
5/8	5/8	5	1 1/4	3	0.020	4	9031900158700	3190
3/4	3/4	4	1 5/8		0.020	4	9031890190500	3189
3/4	3/4	5	1 1/2	3	0.020	4	9031900190500	3190

* Indicates reduced neck style

METRIC

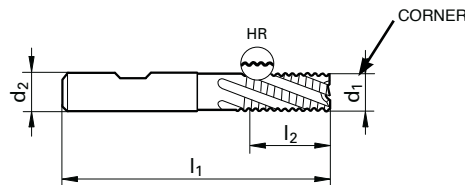

Includes Series

METRIC

3682

Diameter	Shank Diameter	OAL	LOC	Corner		HB	
(d1) mm	(d2) mm	(l1) mm	(l2) mm	Chamfer mm	Flutes	EDP No.	Series Number
6.0	6.0	57	13	0.30	4	9036820060000	3682
8.0	8.0	63	19	0.30	4	9036820080000	3682
10.0	10.0	72	22	0.30	4	9036820100000	3682
12.0	12.0	83	26	0.50	4	9036820120000	3682
16.0	16.0	92	32	0.50	4	9036820160000	3682
20.0	20.0	104	38	0.50	4	9036820200000	3682

FINISH-TECH 50 GH 100 H high-performance end mills for hard milling and superfine finishing



Guhring's hard milling cutters optimally satisfy the requirements for time- and cost-saving machining of hardened workpieces. Different geometries as well as the carbide grade with its high hardness and toughness are optimally adapted for the various milling operations.

Subsequently, Guhring's hard milling cutters achieve highest contour accuracy for cutting depths up to 4xD. Furthermore, milling cutters with full or corner radii are especially suitable for roughing or finishing operations in 3D HSC machining of forms and forging dies.

Advantages:

- application up to 62 HRC
- superior tool rigidity
- high contour accuracy of radii
- excellent surface finish

Micro-corner protection and corrected reinforced cutting edge = optimal stability

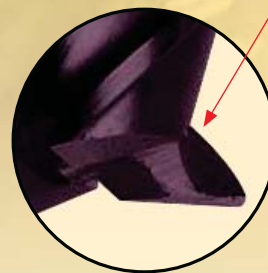

Material	Alloyed Steel	Tool Steel	Cast iron		Stainless steel		Aluminium		Ti-special alloys		H		
	up to 28HRC	over 28 HRC	up to 180 HB 30	over 180 HB 30	up to 28 HRC	over 28 HRC	up to 3% Si	over 3% Si	Ti-based	Ni-based	up to 62 HRC	over 52 HRC	
Finish-Tech 62			○	●							○	●	●

● = optimal suitability

○ = limited suitability

Finish-Tech 50 GH100 U

6/8/10-flute

Includes Series

INCH
3091
3179
3181
3178
3180



TYPE **NH**

HELIX ANGLE **45°**

NUMBER of TEETH **6/8/10**

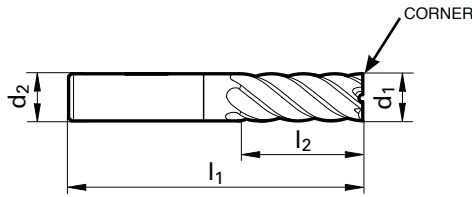

d₁ tolerance h10
 d₂ tolerance h6
 See table on page 150

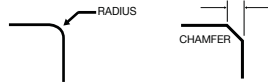

Diameter	Shank Diameter	OAL	LOC	Corner		Flutes	HA		HA	
				Radius Inch	Chamfer Inch		EDP No. FIREX® Coated	Series Number	EDP No. Bright Finish	Series Number
1/4	1/4	2 1/2	3/4	0.015		6	9030910063520	3091		
1/4	1/4	2 1/2	3/4	0.031		6	9030910063540	3091		
1/4	1/4	2 1/2	3/4	0.062		6	9030910063560	3091		
1/4	1/4	2 1/2	3/4		0.004	6	9031790063500	3179	9031780063500	3178
1/4	1/4	3	1 1/8		0.004	6	9031810063500	3181	9031800063500	3180
5/16	5/16	2 1/2	13/16	0.015		6	9030910079420	3091		
5/16	5/16	2 1/2	13/16	0.031		6	9030910079440	3091		
5/16	5/16	2 1/2	13/16	0.062		6	9030910079460	3091		
5/16	5/16	2 1/2	7/8		0.004	6	9031790079400	3179	9031780079400	3178
5/16	5/16	3	1 1/8		0.004	6	9031810079400	3181	9031800079400	3180
3/8	3/8	2 1/2	1	0.015		6	9030910095220	3091		
3/8	3/8	2 1/2	1	0.031		6	9030910095240	3091		
3/8	3/8	2 1/2	1	0.062		6	9030910095260	3091		
3/8	3/8	2 1/2	7/8		0.004	6	9031790095200	3179	9031780095200	3178
3/8	3/8	3	1 1/8		0.004	6	9031810095200	3181	9031800095200	
1/2	1/2	3	1	0.015		6	9030910127020	3091		
1/2	1/2	3	1	0.031		6	9030910127040	3091		
1/2	1/2	3	1	0.062		6	9030910127060	3091		
1/2	1/2	3	1	0.090		6	9030910127070	3091		
1/2	1/2	3	1		0.006	6	9031790127000	3179	9031780127000	3178
1/2	1/2	4 1/2	2		0.006	6	9031810127000	3181	9031800127000	3180
5/8	5/8	3 1/2	1 1/4	0.031		6	9030910158740	3091		
5/8	5/8	3 1/2	1 1/4	0.062		6	9030910158760	3091		
5/8	5/8	3 1/2	1 1/4	0.090		6	9030910158770	3091		
5/8	5/8	3 1/2	1 1/4		0.006	6	9031790158700	3179	9031780158700	3178
5/8	5/8	5	2 1/4		0.006	6	9031810158700	3181	9031800158700	3180
3/4	3/4	4	1 1/2	0.031		8	9030910190540	3091		
3/4	3/4	4	1 1/2	0.062		8	9030910190560	3091		
3/4	3/4	4	1 1/2	0.090		8	9030910190570	3091		
3/4	3/4	4	1 1/2	0.125		8	9030910190590	3091		
3/4	3/4	4	1 1/2		0.006	8	9031790190500	3179	9031780190500	3178
3/4	3/4	5	2 1/4		0.006	8	9031810190500	3181	9031800190500	3180
1	1	4	1 1/2		0.012	10	9031790254000	3179	9031780254000	3178

Finish-Tech 50 GH100 U

6/8/10-flute, FIREX® Coated

Includes Series

METRIC

3047

3563

3693

3689

3691



TYPE **NH**

HELIX ANGLE **45°**

NUMBER of TEETH **6/8/10**

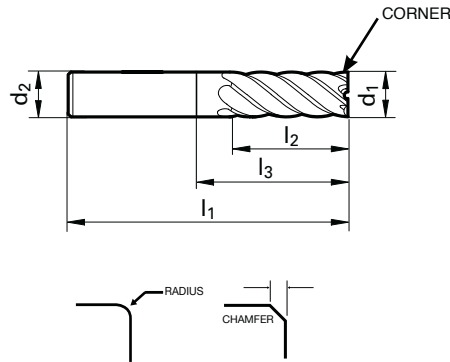

d₁ tolerance h10
d₂ tolerance h6
See table on page 150

Diameter	Shank Diameter	OAL	LOC	Reach	Corner			Flutes	HA		HB	
					Radius mm	Chamfer mm	EDP No.		Series Number	EDP No.	Series Number	
3.0	6.0	57	8			0.05	6	9036890030000	3689			
4.0	6.0	57	11			0.05	6	9036890040000	3689			
5.0	6.0	57	13			0.05	6	9036890050000	3689			
6.0	6.0	57	13	21	0.5		6	9035630060050	3563			
6.0	6.0	57	13	21	1.0		6	9035630060100	3563			
6.0	6.0	57	13			0.05	6	9036890060000	3689	9030470060000	3047	
6.0	6.0	75	30			0.05	6	9036910060000	3691	9036930060000	3693	
8.0	8.0	63	19	27	0.5		6	9035630080050	3563			
8.0	8.0	63	19	27	1.0		6	9035630080100	3563			
8.0	8.0	63	19	27	1.5		6	9035630080150	3563			
8.0	8.0	63	19	27	2.0		6	9035630080200	3563			
8.0	8.0	63	19			0.10	6	9036890080000	3689	9030470080000	3047	
8.0	8.0	100	40			0.10	6	9036910080000	3691	9036930080000	3693	
10.0	10.0	72	22	32	0.5		6	9035630100050	3563			
10.0	10.0	72	22	32	1.0		6	9035630100100	3563			
10.0	10.0	72	22	32	1.5		6	9035630100150	3563			
10.0	10.0	72	22	32	2.0		6	9035630100200	3563			
10.0	10.0	72	22			0.10	6	9036890100000	3689	9030470100000	3047	
10.0	10.0	100	40			0.10	6	9036910100000	3691	9036930100000	3693	
12.0	12.0	83	26	38	0.5		6	9035630120050	3563			
12.0	12.0	83	26	38	1.0		6	9035630120100	3563			
12.0	12.0	83	26	38	1.5		6	9035630120150	3563			
12.0	12.0	83	26	38	2.0		6	9035630120200	3563			
12.0	12.0	83	26			0.15	6	9036890120000	3689	9030470120000	3047	
12.0	12.0	150	45			0.15	6	9036910120000	3691	9036930120000	3693	
14.0	14.0	83	26			0.15	6	9036890140000	3689	9030470140000	3047	
16.0	16.0	92	32	44	1.0		6	9035630160100	3563			
16.0	16.0	92	32	44	1.5		6	9035630160150	3563			
16.0	16.0	92	32	44	2.0		6	9035630160200	3563			
16.0	16.0	92	32			0.15	6	9036890160000	3689	9030470160000	3047	
16.0	16.0	150	65			0.15	6	9036910160000	3691	9036930160000	3693	
18.0	18.0	92	32			0.15	8	9036890180000	3689	9030470180000	3047	
20.0	20.0	104	38	54	1.0		8	9035630200100	3563			
20.0	20.0	104	38	54	1.5		8	9035630200150	3563			
20.0	20.0	104	38	54	2.0		8	9035630200200	3563			
20.0	20.0	104	38			0.15	8	9036890200000	3689	9030470200000	3047	
20.0	20.0	150	65			0.15	8	9036910200000	3691	9036930200000	3693	
25.0	25.0	121	45			0.20	10	9036890250000	3689	9030470250000	3047	

* Indicates reduced neck style

Finish-Tech 50 **GH100 U**

6/8/10-flute, Bright Finish

Includes Series

METRIC

3019

3112

3311

3312

3313



TYPE

NH

HELIX ANGLE



NUMBER of TEETH

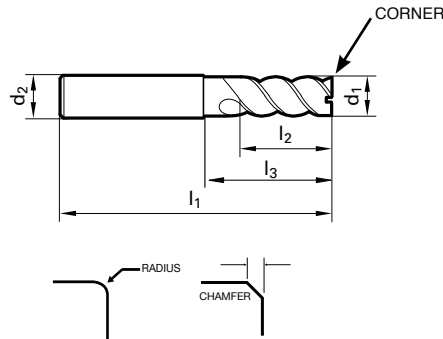

d_1 tolerance h10
 d_2 tolerance h6
 See table on page 150

Diameter	Shank Diameter	OAL	LOC	Reach	Corner		Flutes	HA		HB	
					Radius mm	Chamfer mm		EDP No.	Series Number	EDP No.	Series Number
3.0	6.0	57	8			0.05	6	9033110030000	3311		
4.0	6.0	57	11			0.05	6	9033110040000	3311		
5.0	6.0	57	13			0.05	6	9033110050000	3311		
6.0	6.0	57	13	21	0.5		6	9031120060050	3112		
6.0	6.0	57	13	21	1.0		6	9031120060100	3112		
6.0	6.0	57	13			0.05	6	9033110060000	3311	9030190060000	3019
6.0	6.0	75	30			0.05	6	9033120060000	3112	9033130060000	3313
8.0	8.0	63	19	27	0.5		6	9031120080050	3112		
8.0	8.0	63	19	27	1.0		6	9031120080100	3112		
8.0	8.0	63	19	27	1.5		6	9031120080150	3112		
8.0	8.0	63	19	27	2.0		6	9031120080200	3112		
8.0	8.0	63	19			0.10	6	9033110080000	3311	9030190080000	3019
8.0	8.0	100	40			0.10	6	9033120080000	3312	9033130080000	3313
10.0	10.0	72	22	32	0.5		6	9031120100050	3112		
10.0	10.0	72	22	32	1.0		6	9031120100100	3112		
10.0	10.0	72	22	32	1.5		6	9031120100150	3112		
10.0	10.0	72	22	32	2.0		6	9031120100200	3112		
10.0	10.0	72	22			0.10	6	9033110100000	3311	9030190100000	3019
10.0	10.0	100	40			0.10	6	9033120100000	3312	9033130100000	3313
12.0	12.0	83	26	38	0.5		6	9031120120050	3112		
12.0	12.0	83	26	38	1.0		6	9031120120100	3112		
12.0	12.0	83	26	38	1.5		6	9031120120150	3112		
12.0	12.0	83	26	38	2.0		6	9031120120200	3112		
12.0	12.0	83	26			0.15	6	9033110120000	3311	9030190120000	3019
12.0	12.0	150	45			0.15	6	9033120120000	3312	9033130120000	3313
14.0	14.0	83	26			0.15	6	9033110140000	3311	9030190140000	3019
16.0	16.0	92	32	44	1.0		6	9031120160100	3112		
16.0	16.0	92	32	44	1.5		6	9031120160150	3112		
16.0	16.0	92	32	44	2.0		6	9031120160200	3112		
16.0	16.0	92	32			0.15	6	9033110160000	3311	9030190160000	3019
16.0	16.0	150	65			0.15	6	9033120160000	3312	9033130160000	3313
18.0	18.0	92	32			0.15	8	9033110180000	3311	9030190180000	3019
20.0	20.0	104	38	54	1.0		8	9031120200100	3112		
20.0	20.0	104	38	54	1.5		8	9031120200150	3112		
20.0	20.0	104	38	54	2.0		8	9031120200200	3112		
20.0	20.0	104	38			0.15	8	9033110200000	3311	9030190200000	3019
20.0	20.0	150	65			0.15	8	9033120200000	3312	9033130200000	3313
25.0	25.0	121	45			0.20	10	9033110250000	3311	9030190250000	3019

* Indicates reduced neck style

Finish-Tech 50 GH100 U

nano-Si[®] coated, 6-flute

Includes Series
INCH
3084



TYPE	NH
HELIX ANGLE	45°
NUMBER of TEETH	6/8

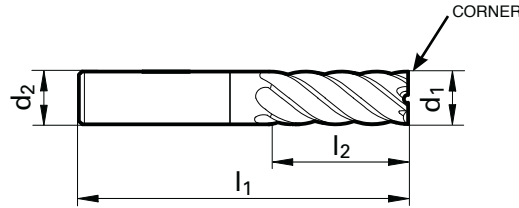

d₁ tolerance h10
d₂ tolerance h6
See table on page 150

Diameter	Shank Diameter	OAL	LOC	Corner		HA	
(d1) mm	(d2) mm	(l1) mm	(l2) mm	Chamfer mm	Flutes	EDP No.	Series Number
1/4	1/4	2 1/2	3/4	0.004	6	9030840063500	3084
5/16	5/16	2 1/2	7/8	0.004	6	9030840079400	3084
3/8	3/8	2 1/2	7/8	0.004	6	9030840095200	3084
1/2	1/2	3	1	0.006	6	9030840127000	3084
5/8	5/8	3 1/2	1 1/4	0.006	6	9030840158700	3084
3/4	3/4	4	1 1/2	0.006	8	9030840190500	3084

ULTRA-HARD COATING!



nano-Si[®]

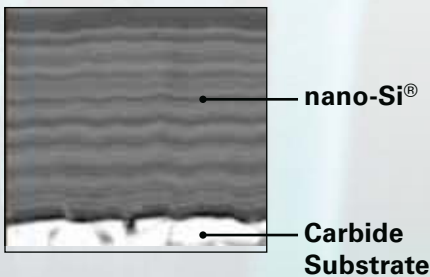

Gühring's coatings research department has developed a new nano multi-layer coating for nickel base materials and hardened materials that require high surface hardness coatings. Called nano-Si[®], this TiAlSiN (titanium aluminum silicon nitride) based coating is designed to yield similar performance to diamond-like coatings without the restrictions on the host base material substrate. With a hardness value of 5,500 (HV 0.05), nano-Si[®] stands up to the most abrasive applications. The oxidation, or maximum useful operating temperature, is over 1,470° F, which is similar to high temperature coatings such as FIREX[®] or TiAlN.

Test results in milling inconel have shown a 35% increase in tool life compared to a comparable TiAlN based multi-layer coating using the same operating parameters. Similar results were found when machining cast iron and hardened steels over 52HRc.

No other coating can provide this high hardness property while still retaining the toughness required in drilling and milling applications.

FINISH-TECH 62 GH100 H

FIREX® Coated, **6/8-flute**

Includes Series

INCH

3182

3183



TYPE

H

HELIX ANGLE

55°

NUMBER of TEETH

6/8

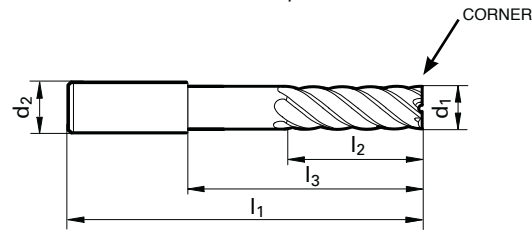

d₁ tolerance h10
d₂ tolerance h6
See table on page 150

Diameter	Shank Diameter	OAL	LOC	Reach	Corner	HA		
(d1) Frac	(d2) Frac	(l1) Frac	(l2) Frac	*(l3) Frac	Chamfer Inch	Flutes	EDP No.	Series Number
1/4	1/4	2 1/2	3/4		0.004	6	9031820063500	3182
1/4	1/4	3	3/4	1 1/2	0.004	6	9031830063500	3183
5/16	5/16	2 1/2	7/8		0.004	6	9031820079400	3182
5/16	5/16	3	7/8	1 1/2	0.004	6	9031830079400	3183
3/8	3/8	2 1/2	7/8		0.004	6	9031820095200	3182
3/8	3/8	3	7/8	1 1/2	0.004	6	9031830095200	3183
1/2	1/2	3	1		0.006	6	9031820127000	3182
1/2	1/2	4 1/2	1	2 3/4	0.006	6	9031830127000	3183
5/8	5/8	3 1/2	1 1/4		0.006	6	9031820158700	3182
5/8	5/8	5	1 1/4	3	0.006	6	9031830158700	3183
3/4	3/4	4	1 1/2		0.006	8	9031820190500	3182
3/4	3/4	5	1 1/2	3	0.006	8	9031830190500	3183

* Indicates reduced neck style

FINISH-TECH 62 GH100 H

FIREX® Coated, **6/8-flute**

Includes Series

METRIC

3715

3716

TYPE	H
HELIX ANGLE	55°
NUMBER of TEETH	6/8

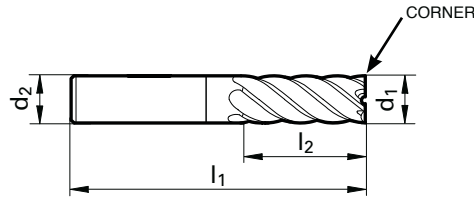

d₁ tolerance h10
d₂ tolerance h6
See table on page 150

Diameter	Shank Diameter	OAL	LOC	Corner		HA	
(d1) mm	(d2) mm	(l1) mm	(l2) mm	Chamfer mm	Flutes	EDP No.	Series Number
3.0	6.0	57	8	0.05	6	90 3715 003 0000	3715
4.0	6.0	57	11	0.05	6	90 3715 004 0000	3715
5.0	6.0	57	13	0.05	6	90 3715 005 0000	3715
6.0	6.0	57	13	0.05	6	90 3715 006 0000	3715
6.0	6.0	75	30	0.05	6	90 3716 006 0000	3716
8.0	8.0	63	19	0.10	6	90 3715 008 0000	3715
8.0	8.0	100	40	0.10	6	90 3716 008 0000	3716
10.0	10.0	72	22	0.10	6	90 3715 010 0000	3715
10.0	10.0	150	40	0.10	6	90 3716 010 0000	3716
12.0	12.0	83	26	0.15	6	90 3715 012 0000	3715
12.0	12.0	150	45	0.15	6	90 3716 012 0000	3716
14.0	14.0	83	26	0.15	6	90 3715 014 0000	3715
16.0	16.0	92	32	0.15	6	90 3715 016 0000	3715
16.0	16.0	150	65	0.15	6	90 3716 016 0000	3716
18.0	18.0	92	32	0.15	8	90 3715 018 0000	3715
20.0	20.0	104	38	0.15	8	90 3715 020 0000	3715
20.0	20.0	150	65	0.15	8	90 3716 020 0000	3716

DID YOU KNOW GUHRING HAS TOOL HOLDERS?

Guhring offers a complete line of tool holders and clamping systems.

FEATURING:

TSG 3000

Thermo Secure Gold 3000
High-End Shrink Fit Chuck

Up until now one couldn't tell a chuck's temperature. With the optical temperature indicator on Guhring Thermo Secure Gold 3000 chucks, this source of danger is a thing of the past.

A red ring signals:

Attention, hot! Risk of burning!

The chuck has a temperature above 113° F.

When the temperature drops below 113° F, the ring turns blue.

The chuck can now be held without danger.

With a shrink fitted tool optimal clamping is now achieved.



GF 300 B and GF 300 T: Ball nose and Torus end mills for high performance milling in materials < 62 HRC



Reduced neck ground for collision reduction

High wear protection thanks to radius geometry with constant rake angle and continuous spiral.

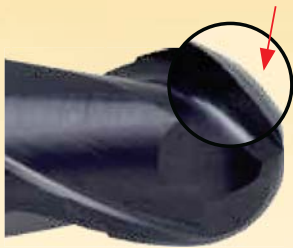

Seamless radius area provides high form and contour accuracy.

The die and mold industry places ever higher demands on milling cutters – primarily with regard to accuracy and tool life. Therefore, Guhring’s cutting tool program now includes radius milling cutters that are perfectly adapted to satisfy these demands and provide optimal machining results thanks to application orientated geometries, carbide grades and coatings. The advantages are especially high form and contour accuracy of the workpiece, minimal wear and therefore excellent tool life.

The special features of Guhring’s ball nose milling cutters are:

- outside diameter and the radius is ground in one-pass
- radius point geometry with constant helix-radius-correction
- reduced neck ground for collision reduction with protruding edges

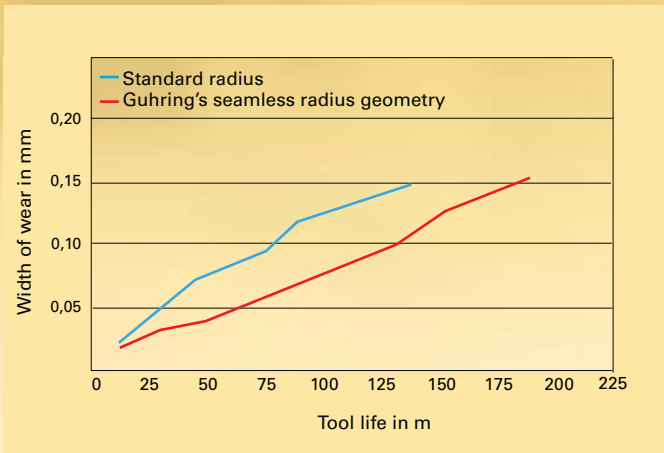

Wear comparison: Guhring’s seamless radius geometry reduces wear and provides a considerably longer tool life in comparison with tools ground with conventional full radius.

Material	Alloyed Steel	Tool Steel	Cast iron		Stainless steel		Aluminium		Ti-special alloys		H	
	up to 28Hrc	over 28 Hrc	up to 180 HB 30	over 180 HB 30	up to 28 Hrc	over 28 Hrc	up to 3% Si	over 3% Si	Ti-based	Ni-based	up to 52 HRC	over 52 HRC
GF 500	○	●	●	●	○	○			●	●	●	
GF 300		○	○	●					○	○	●	●

● = optimal suitability

○ = limited suitability

GF300 B

Ball nose, FIREX® Coated, **2-flute**

Includes Series

INCH

3101

3191



TYPE	H
HELIX ANGLE	30°
NUMBER of TEETH	2

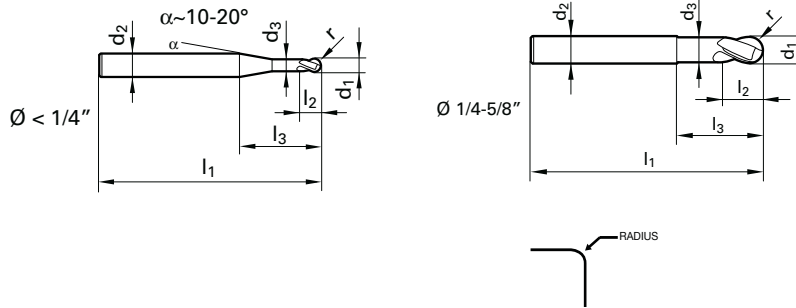

d₁ tolerance h8
d₂ tolerance h6
See table on page 150

Diameter	Shank Diameter		OAL	LOC	Reach	Corner	HA	
(d1) Frac	(d2) Frac	(d3) Inch	(l1) Frac	(l2) Frac	*(l3) Frac	Radius Inch	EDP No.	Series Number
1/8	1/4	0.113	2	1/8	1/2	0.063	9031010031700	3101
1/8	1/4	0.113	2 1/2	1/8	1	0.063	9031910031700	3191
3/16	1/4	0.176	2	3/16	1/2	0.094	9031010047600	3101
3/16	1/4	0.176	2 1/2	3/16	1	0.094	9031910047600	3191
1/4	1/4	0.238	2	1/4	11/16	0.125	9031010063500	3101
1/4	1/4	0.238	3	1/4	1 1/2	0.125	9031910063500	3191
5/16	5/16	0.300	2	5/16	1 3/16	0.156	9031010079400	3101
5/16	5/16	0.300	3	5/16	1 1/2	0.156	9031910079400	3191
3/8	3/8	0.363	2 1/2	3/8	1 3/16	0.188	9031010095200	3101
3/8	3/8	0.363	3	3/8	1 1/2	0.188	9031910095200	3191
1/2	1/2	0.480	3	1/2	1 7/16	0.250	9031010127000	3101
1/2	1/2	0.480	4 1/2	1/2	2 3/4	0.250	9031910127000	3191
5/8	5/8	0.605	5	5/8	3	0.313	9031910158700	3191

* Indicates reduced neck style

GF300 B

Ball nose, FIREX® Coated, 2-flute

Includes Series

METRIC

3359

3360

TYPE **H**

HELIX ANGLE **30°**

NUMBER of TEETH **2**

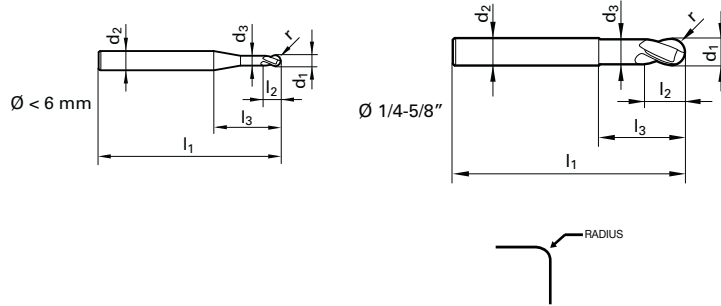

d_1 tolerance h8
 d_2 tolerance h6
 See table on page 150

Diameter	Shank Diameter		OAL	LOC	Reach	Corner	HA	
(d1) mm	(d2) mm	(d3) mm	(l1) mm	(l2) mm	* (l3) mm	Radius mm	EDP No.	Series Number
0.5	3.0	0.4	38	1	10	0.25	9033590005000	3359
0.8	3.0	0.7	38	1	10	0.40	9033590008000	3359
1.0	3.0	0.9	38	2	10	0.50	9033590010000	3359
1.5	3.0	1.4	38	2	10	0.75	9033590015000	3359
2.0	6.0	1.9	57	3	21	1.00	9033590020000	3359
3.0	6.0	2.7	57	5	21	1.50	9033590030000	3359
3.0	6.0	2.7	75	5	39	1.50	9033600030000	3360
4.0	6.0	3.7	57	6	21	2.00	9033590040000	3359
4.0	6.0	3.1	75	6	39	2.00	9033600040000	3360
5.0	6.0	4.7	57	8	21	2.50	9033590050000	3359
5.0	6.0	4.7	75	8	39	2.50	9033600050000	3360
6.0	6.0	5.7	57	9	21	3.00	9033590060000	3359
6.0	6.0	5.7	75	9	39	3.00	9033600060000	3360
8.0	8.0	7.7	63	12	27	4.00	9033590080000	3359
8.0	8.0	7.7	100	12	64	4.00	9033600080000	3360
10.0	10.0	9.5	72	15	32	5.00	9033590100000	3359
10.0	10.0	9.5	100	15	60	5.00	9033600100000	3360
12.0	12.0	11.5	83	18	38	6.00	9033590120000	3359
12.0	12.0	11.5	150	18	105	6.00	9033600120000	3360
16.0	16.0	15.5	92	24	44	8.00	9033590160000	3359
16.0	16.0	15.5	150	24	102	8.00	9033600160000	3360

* Indicates reduced neck style

GF300 T

Torus form, FIREX® Coated, 4-flute

Includes Series

INCH

3192



TYPE

H

HELIX ANGLE

30°

NUMBER of TEETH

4

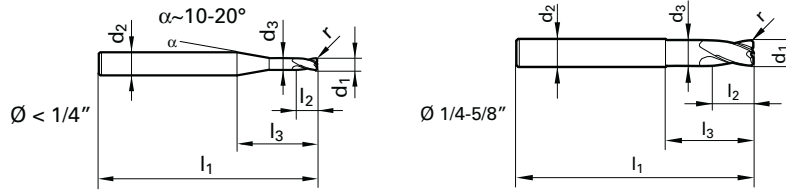

d_1 tolerance h8
 d_2 tolerance h6
 See table on page 150

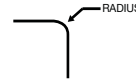

Diameter	Shank Diameter		OAL	LOC	Reach		Corner	HA	
(d1) Frac	(d2) Frac	(d3) Inch	(l1) Frac	(l2) Frac	*(l3) Frac	(l4) Frac	Radius Inch		EDP No. Series Number
3/16	1/4	0.175	2 1/2	3/16	3/4	1	0.008		9031920047600 3192
1/4	1/4	0.230	3	1/4	1 1/2		0.010		9031920063500 3192
5/16	5/16	0.292	3	5/16	1 1/2		0.013		9031920079400 3192
3/8	3/8	0.355	3	3/8	1 1/2		0.013		9031920095200 3192
1/2	1/2	0.480	4 1/2	1/2	2 3/4		0.020		9031920127000 3192
5/8	5/8	0.605	5	5/8	3		0.025		9031920158700 3192

* Indicates reduced neck style

METRIC

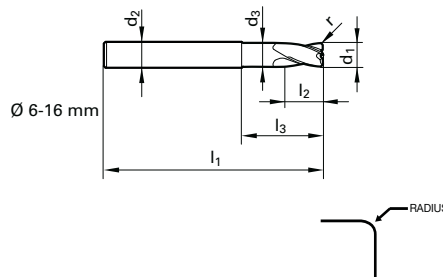

Includes Series

METRIC

3362

Diameter	Shank Diameter		OAL	LOC	Reach	Corner	HA	
(d1) Frac	(d2) Frac	(d3) Inch	(l1) Frac	(l2) Frac	*(l3) Frac	Radius Inch		EDP No. Series Number
6.0	6.0	5.7	75	9	39	1.0		9033620060000 3362
8.0	8.0	7.7	100	12	64	1.0		9033620080000 3362
10.0	10.0	9.5	100	15	60	1.5		9033620100000 3362
12.0	12.0	11.5	150	18	105	1.5		9033620120000 3362
16.0	16.0	15.5	150	24	102	2.0		9033620160000 3362

* Indicates reduced neck style

GF 500 HSC Trace Milling Cutters with ball nose or Torus form -

GF 500 HSC (High Speed Cutting) trace milling cutters are suitable for all roughing, finishing as well as fine finishing operations under HSC conditions in the mould and die industry. The range of application includes all general steels as well as high-alloyed steels but also hardened materials from 40 to 54 HRC.

The new web thinning form provides optimal chip evacuation as well as stability. In addition, the extremely close tolerances on radius and diameter ensure a very high contour accuracy on the workpiece, improving tool life considerably. A completely new grinding process produces considerably smoother cutting edges and flutes and also results in a clear increase in tool life. GF 500 B HSC ball nose trace milling cutters and GF 500 T HSC trace milling cutters with Torus form are both available with different lengths. The combination of the new geometries with reinforced shanks as well as reduced neck diameters allows extremely high feed rates and also provides high rigidity and optimal collision protection even for increased cutting depths.

Advantages at a glance:

- accurate tolerances on diameter
- close radius tolerances
- radius grind with constant helix correction
- straight and radius areas ground in one pass
- grinding process for highest Surface finish finishes

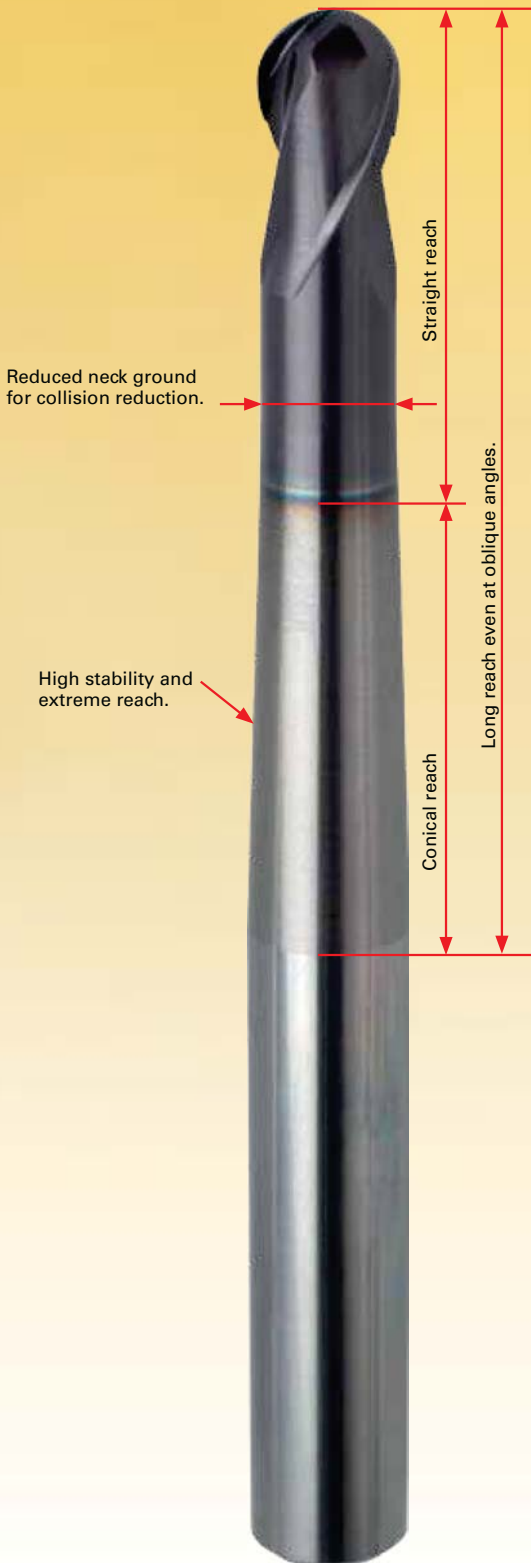

Optimal wear protection thanks to radius grind with constant rake angle and continuous helix.

Seamless radius area provides high form and contour accuracy.

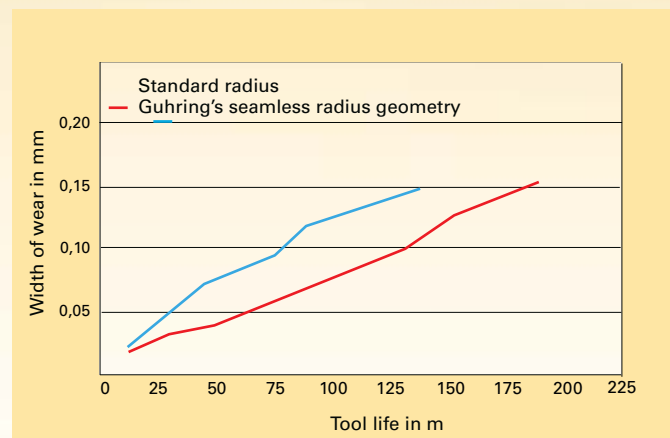

Pic. 1: Wear comparison
Guhring's seamless radius geometry reduces wear and provides a considerably longer tool life in comparison with tools ground with conventional full radius.

For highest accuracy in the mold and die industry

GF 500 milling cutters benefit from considerably smoother cutting edges and flutes produced by a completely new grinding process. It results in a reduction in crumbling of the cutting edges and therefore increases tool life. In addition, wear is extremely even, allowing more economical and frequent regrinding of the tools and providing further cost advantages.

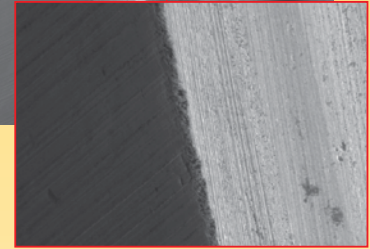
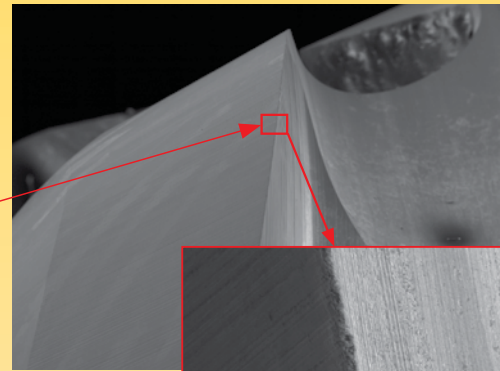

GF 500 cutting edge, produced with the new Guhring grinding process

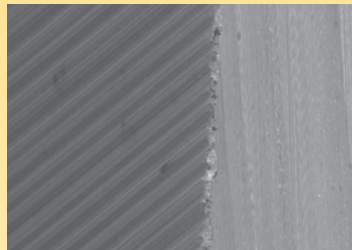

Cutting edge of the competitor tool, produced by conventional grinding process

As well as high Surface finish qualities, close radius tolerances are achieved. Subsequently, GF 500 milling cutters offer very high form accuracy as well as considerable tool life increases up to 60 % in comparison to conventional tools.

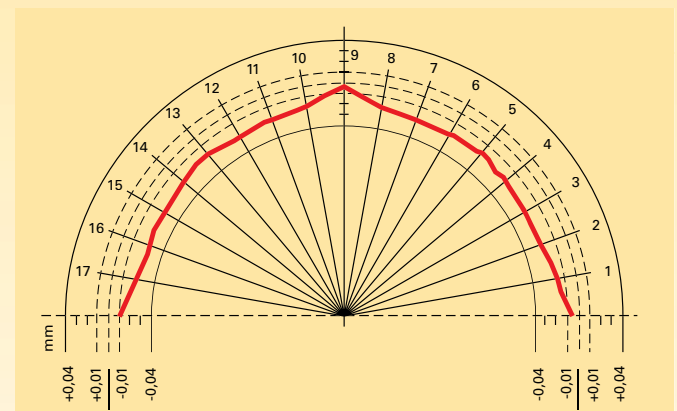

Radius accuracy of competitor tool
(± 0.05 mm, $\pm 0.002''$)

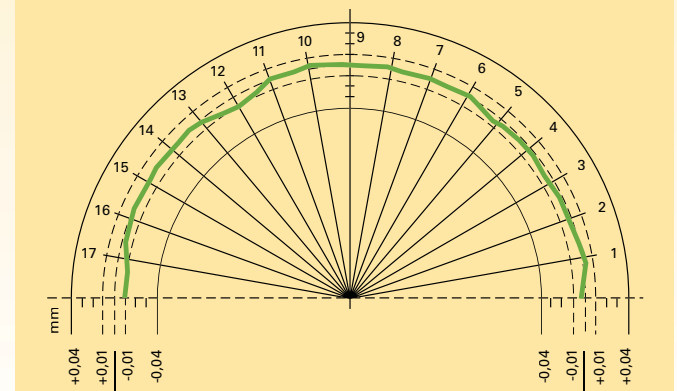

GF 500 radius tolerance
(± 0.01 mm, $\pm 0.0004''$)

Material	Alloyed Steel	Tool Steel	Cast iron	Stainless steel	Aluminium	Ti-special alloys	H				
	up to 28HRC	over 28 HRC		up to 180 HB 30	over 180 HB 30	up to 28 HRC		over 28 HRC	up to 3% Si	over 3% Si	Ti-based
GF 300		○	○	●				○	○	●	●

● = optimal suitability

○ = limited suitability

GF500 B

β° Ball nose, TiALN Coated, 2-flute

Includes Series

METRIC

3848

3849

3853

3854

3855

3866

TYPE **N**

HELIX ANGLE **30°**

NUMBER of TEETH **2**

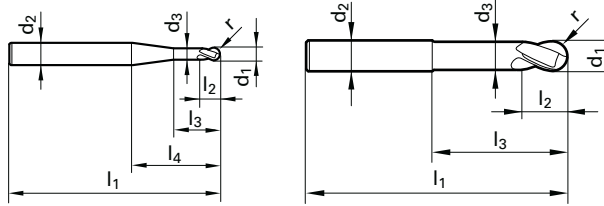
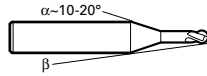

d_1 tolerance h8
 d_2 tolerance h6
 See table on page 150

Diameter	Shank Diameter		OAL	LOC	Reach		Corner	Collision Angle	HA	
(d1) mm	(d2) mm	(d3) mm	(l1) mm	(l2) mm	*(l3) mm	(l4) mm	Radius Inch	β°		EDP No. Series Number
2.0	6.0	1.8	57	3	6.2	20	1.0	5.7		9038480020000 3848
2.0	6.0	1.8	80	3	8	40	1.0	2.9		9038490020000 3849
2.0	6.0	1.8	80	3	8	40	1.0	1.0		9038530020000 3853
3.0	6.0	2.8	57	3.5	8.4	20	1.5	4.3		9038480030000 3848
3.0	6.0	2.8	80	3.5	12	40	1.5	2.2		9038490030000 3849
3.0	6.0	2.8	80	3.5	12	40	1.5	1.0		9038530030000 3853
4.0	6.0	3.8	57	4	9.4	20	2.0	2.9		9038480040000 3848
4.0	6.0	3.8	80	4	20	40	2.0	1.4		9038490040000 3849
4.0	4.0		80	8			2.0			9038660040000 3866
4.0	6.0	3.8	100	4	20	60	2.0	1.0		9038530040000 3853
5.0	6.0	4.7	80	5	25	40	2.5	0.7		9038490050000 3849
6.0	6.0	5.6	57	6	20		3.0			9038480060000 3848
6.0	6.0		57	12			3.0			9038540060000 3854
6.0	6.0	5.6	80	6	45		3.0			9038550060000 3855
6.0	8.0	5.6	100	6	25	60	3.0	1.0		9038490060000 3849
6.0	6.0		100	12			3.0			9038660060000 3866
6.0	8.0	5.6	120	6	25	80	3.0	1.0		9038530060000 3853
8.0	8.0	7.6	63	7	26		4.0			9038480080000 3848
8.0	8.0		63	16			4.0			9038540080000 3854
8.0	8.0	7.6	100	7	65		4.0			9038550080000 3855
8.0	8.0		100	16			4.0			9038660080000 3866
8.0	10.0	7.6	120	7	30	75	4.0	0.8		9038490080000 3849
8.0	10.0	7.6	150	7	20	105	4.0	0.6		9038530080000 3853
10.0	10.0	9.6	72	8	30		5.0			9038480100000 3848
10.0	10.0		72	20			5.0			9038540100000 3854
10.0	10.0		100	20			5.0			9038660100000 3866
10.0	12.0	9.6	120	8	30	70	5.0	0.8		9038490100000 3849
10.0	10.0	9.6	120	8	80		5.0			9038550100000 3855
12.0	12.0	11.5	83	10	35		6.0			9038480120000 3848
12.0	12.0		83	24			6.0			9038540120000 3854
12.0	12.0	11.5	120	10	75		6.0			9038550120000 3855
12.0	12.0		120	24			6.0			9038660120000 3866
12.0	16.0	11.5	150	10	35	100	6.0	1.2		9038490120000 3849

* Indicates reduced neck style

GF500 T

Torus form, TiALN Coated, 2-flute

Includes Series

METRIC
3856
3859
3860
3863
3865



TYPE	N
HELIX ANGLE	30°
NUMBER of TEETH	2

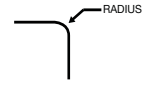
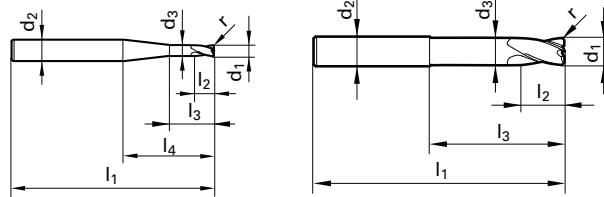

d₁ tolerance h8
d₂ tolerance h6
See table on page 150

Diameter	Shank Diameter		OAL	LOC	Reach		Corner	Collision Angle	HA	
(d1) mm	(d2) mm	(d3) mm	(l1) mm	(l2) mm	*(l3) mm	(l4) mm	Radius Inch	β°		EDP No. Series Number
2.0	6.0	1.8	57	3	6.2	20	0.5	5.7		9038560020000 3856
2.0	6.0	1.8	80	3	8	40	0.5	2.9		9038590020000 3859
2.0	6.0	1.8	80	3	8	40	0.5	1.0		9038600020000 3860
3.0	6.0	2.8	57	3.5	8.4	20	0.5	4.3		9038560030000 3856
3.0	6.0	2.8	80	3.5	12	40	0.5	2.2		9038590030000 3859
3.0	6.0	2.8	80	3.5	12	40	0.5	1.0		9038600030000 3860
4.0	6.0	3.8	57	4	9.4	20	1.0	2.9		9038560040000 3856
4.0	6.0	3.8	80	4	20	40	1.0	1.4		9038590040000 3859
4.0	4.0		80	8			0.5			9038630040000 3863
4.0	6.0	3.8	100	4	20	60	0.5	1.0		9038600040000 3860
6.0	6.0	5.6	57	6	20		2.0			9038560060000 3856
6.0	6.0	5.6	80	6	45		2.0			9038650060000 3865
6.0	8.0	5.6	100	6	25	60	2.0	1.0		9038590060000 3859
6.0	6.0		100	12			1.0			9038630060000 3863
6.0	8.0	5.6	120	6	25	80	1.0	1.0		9038600060000 3860
8.0	8.0	7.6	63	7	26		2.0			9038560080000 3856
8.0	8.0	7.6	100	7	65		2.0			9038650080000 3865
8.0	8.0		100	16			1.0			9038630080000 3863
8.0	10.0	7.6	120	7	30	75	2.0	0.8		9038590080000 3859
8.0	10.0	7.6	150	7	20	105	1.0	0.6		9038600080000 3860
10.0	10.0	9.6	72	8	30		3.0			9038560100000 3856
10.0	10.0		100	20			1.0			9038630100000 3863
10.0	12.0	9.6	120	8	30	70	3.0	0.8		9038590100000 3859
10.0	12.0	9.6	120	8	70		3.0			9038650100000 3865
12.0	12.0	11.5	83	10	35		4.0			9038560120000 3856
12.0	12.0	11.5	120	10	75		4.0			9038650120000 3865
12.0	12.0		120	24			1.5			9038630120000 3863
12.0	16.0	11.5	150	10	35	100	4.0	1.2		9038590120000 3859

* Indicates reduced neck style

PRO-LINE

GENERAL PURPOSE SOLUTIONS

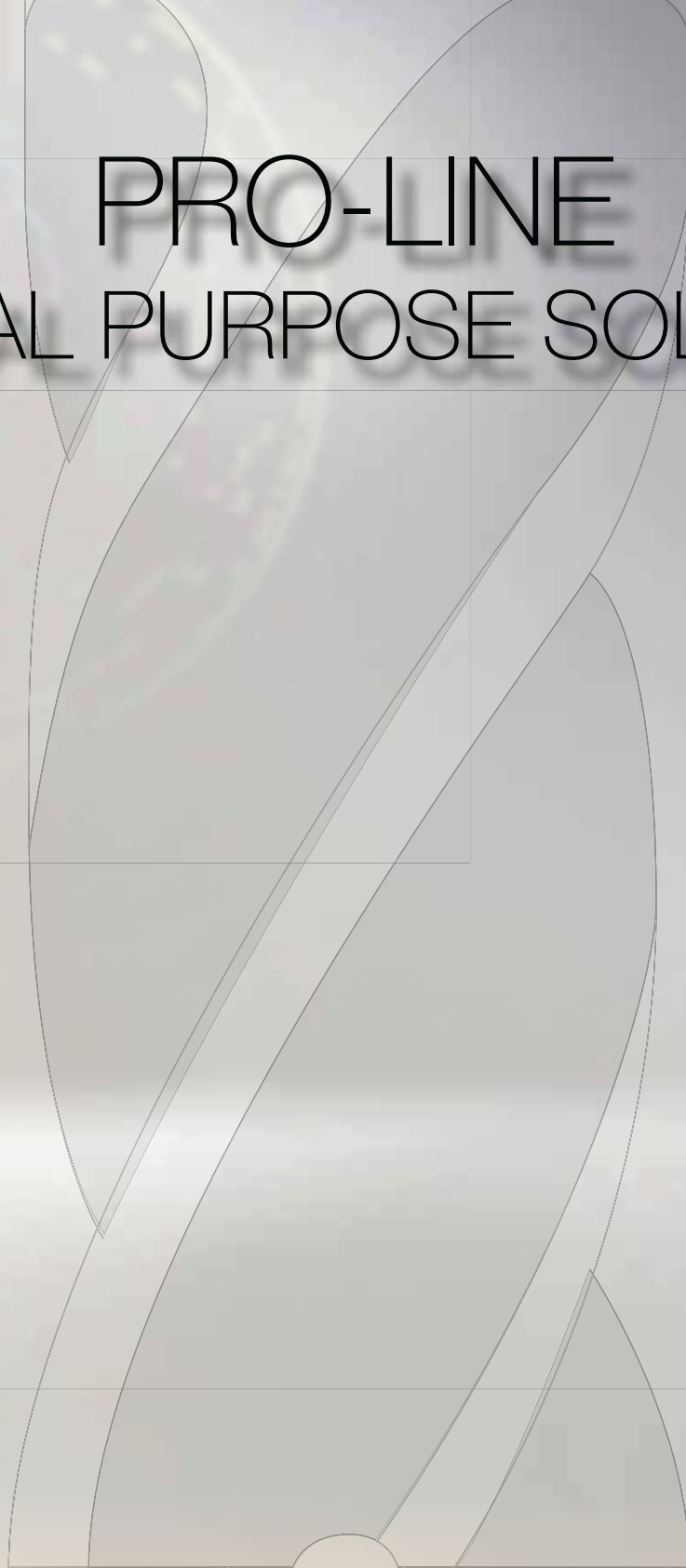



Type	Helix angle	Number of teeth	Length	Tool description	Tool material Surface finish	Gurthing no.	Gurthing no.	Unit	Diameter Range	Page
						HA	HB			
UNI PRO end mills (2-fluted)					carbide					
N	30°	2			FIREX®	3092		Inch	1/16 - 3/4	126
N	30°	2			FIREX®	3633	3634	Metric	2 - 20	128
N	30°	2			Bright	3146		Inch	1/16 - 1	126
N	30°	2			Bright	3303		Metric	2 - 20	128
N	30°	2			FIREX®	3148		Inch	1/16 - 1	126
N	30°	2			FIREX®	3676		Metric	2 - 20	128
N	30°	2			Super-AT™	3846		Inch	1/16 - 1	126
N	30°	2			Bright	3147		Inch	1/8 - 1	126
N	30°	2			FIREX®	3149		Inch	1/8 - 1	126
N	30°	2			Super-AT™	3847		Inch	1/8 - 1	126
N	30°	2			Bright	3011		Metric	3 - 20	128
N	30°	2			FIREX®	3021		Metric	3 - 20	128

Type	Helix angle	Number of teeth	Length	Tool description	Tool material Surface finish	Gurthing no.	Gurthing no.	Unit	Diameter Range	Page
						HA	HB			
UNI PRO end mills (2-fluted) with corner radius					carbide					
N	30°	2			FIREX®	3087		Inch	1/8 - 1/2	126
N	30°	2			Bright	3106		Metric	6 - 20	128
N	30°	2			FIREX®	3561		Metric	6 - 20	128
N	30°	2			FIREX®	3088		Inch	1/8 - 1/2	126
UNI PRO end mills (3-fluted)					carbide					
N	30°	3			FIREX®	3558	3719	Metric	2 - 16	131
N	30°	3			Bright	3168		Inch	1/8 - 1	130
N	30°	3			Bright	3307		Metric	2 - 20	131
N	30°	3			FIREX®	3170		Inch	1/8 - 1	130
N	30°	3			Super-A™	3868		Inch	1/8 - 1	130
N	30°	3			FIREX®	3677		Metric	2 - 20	131
N	30°	3			Bright	3169		Inch	3/16 - 1	130
N	30°	3			FIREX®	3171		Inch	3/16 - 1	130
N	30°	3			Super-A™	3869		Inch	3/16 - 1	130
N	30°	3			Bright	3314		Metric	3 - 20	131
N	30°	3			FIREX®	3680		Metric	3 - 20	131

Type	Helix angle	Number of teeth	Length	Tool description	Tool material Surface finish	Gurhing no. HA	Gurhing no. HB	Unit	Diameter Range	Page
UNI PRO end mills (4-fluted)					carbide					
N	30°	4			FIREX®	3093		Inch	1/16 - 3/4	133
N	30°	4			FIREX®	3637	3721	Metric	2 - 20	136
N	30°	4			Bright	3150		Inch	1/16 - 1	133
N	30°	4			FIREX®	3153		Inch	1/16 - 1	133
N	30°	4			Super-AT™	3850		Inch	1/16 - 1	133
N	30°	4			Bright	3304		Metric	4 - 20	136
N	30°	4			FIREX®	3678		Metric	4 - 20	136
N	30°	4			Bright	3152		Inch	1/8 - 1	133
N	30°	4			FIREX®	3156		Inch	1/8 - 1	133
N	30°	4			Super-AT™	3852		Inch	3/16 - 1	133
N	30°	4			Bright	3151		Inch	1/6 - 1	133
N	30°	4			FIREX®	3155		Inch	1/4 - 1	133
N	30°	4			Super-AT™	3851		Inch	3/16 - 1	133
N	30°	4			Bright	3012		Metric	3 - 20	136
N	30°	4			FIREX®	3023		Metric	3 - 20	136
UNI PRO "R" end mills (4-fluted) with corner radius					carbide					
N	30°	4			FIREX®	3089		Inch	1/8 - 1/2	133
N	30°	4			Bright	3111		Metric	6 - 20	136
N	30°	4			FIREX®	3562		Metric	6 - 20	136
N	30°	4			FIREX®	3090		Inch	1/4 - 1/2	133

Type	Helix angle	Number of teeth	Length	Tool description	Tool material Surface finish	Gurhing no. HA	Gurhing no. HB	Unit	Diameter Range	Page
UNI PRO ball nose end mills (2-fluted)					carbide					
N	30°	2			Bright	3157		Inch	1/16 - 1	138
N	30°	2			FIREX®	3159		Inch	1/16 - 1	138
N	30°	2			Super-A™	3857		Inch	1/16 - 3/4	138
N	30°	2			Bright	3308	3024	Metric	.5 - 20	139
N	30°	2			FIREX®	3679	3049	Metric	.5 - 20	139
N	30°	2			Bright	3158		Inch	1/8 - 3/4	138
N	30°	2			FIREX®	3160		Inch	1/8 - 3/4	138
N	30°	2			Super-A™	3858		Inch	1/8 - 3/4	138
N	30°	2			Bright	3014		Metric	3 - 12	139
N	30°	2			FIREX®	3030		Metric	3 - 12	139

Type	Helix angle	Number of teeth	Length	Tool description	Tool material Surface finish	Gurhing no. HA	Gurhing no. HB	Unit	Diameter Range	Page
UNI PRO ball nose end mills (4-fluted)					carbide					
N	30°	4			Bright	3161		Inch	1/16 - 1	140
N	30°	4			FIREX®	3165		Inch	1/16 - 1	140
N	30°	4			Super-A™	3861		Inch	1/16 - 3/4	140
N	30°	4			Bright	3306		Metric	4 - 20	141
N	30°	4			FIREX®	3727		Metric	4 - 20	141
N	30°	4			Bright	3164		Inch	1/8 - 3/4	140
N	30°	4			FIREX®	3167		Inch	1/8 - 3/4	140
N	30°	4			Super-A™	3864		Inch	1/8 - 3/4	140
N	30°	4			Bright	3162		Inch	3/16 - 3/4	140
N	30°	4			FIREX®	3166		Inch	3/16 - 5/8	140
N	30°	4			Super-A™	3862		Inch	3/16 - 5/8	140
N	30°	4			Bright	3015		Metric	3 - 12	141
N	30°	4			FIREX®	3043		Metric	3 - 12	141

Quality Tools Need Quality Holders

GUHRING OFFERS A COMPLETE
LINE OF TOOL HOLDERS AND
CLAMPING SYSTEMS



Uni-Pro 2-flute

Includes Series

INCH

3146

3147

3148

3092

3087

3149

3088

3846

3847



TYPE	N
HELIX ANGLE	30°
NUMBER of TEETH	2

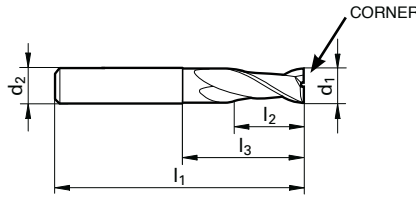

d₁ tolerance h10
d₂ tolerance h6
See table on page 150



Diameter	Shank Diameter	OAL	LOC	Corner		HA		HA		HA	
				Radius Inch	Chamfer Inch	EDP No. Bright Finish	Series Number	EDP No. FIREX® Coated	Series Number	EDP No. Super-A Coated	Series Number
1/16	1/8	1 1/2	3/16		0.001	9031460015900	3146	9031480015900	3148	9038460015900	3846
1/16	1/8	2	1/8		0.001			9030920015900	3092		
5/64	1/8	1 1/2	1/4		0.001	9031460019800	3146	9031480019800	3148		
3/32	1/8	1 1/2	9/32		0.002	9031460023800	3146	9031480023800	3148	9038460023800	3846
7/64	1/8	1 1/2	3/8		0.002	9031460027800	3146	9031480027800	3148		
1/8	1/8	1 1/2	3/8		0.002	9031460031700	3146	9031480031700	3148	9038460031700	3846
1/8	1/8	1 1/2	3/8	0.015				9030870031720	3087		
1/8	1/8	1 1/2	3/8	0.031				9030870031740	3087		
1/8	1/8	2	1/4		0.002			9030920031700	3092		
1/8	1/8	2	1/2		0.002	9031470031700	3147	9031490031700	3149	9038470031700	3847
1/8	1/8	2	1/2	0.015				9030880031720	3088		
1/8	1/8	2	1/2	0.031				9030880031740	3088		
9/64	3/16	2	1/2		0.002	9031460035700	3146	9031480035700	3148		
5/32	3/16	2	1/2		0.002	9031460039700	3146	9031480039700	3148	9038460039700	3846
11/64	3/16	2	5/8		0.002	9031460043700	3146	9031480043700	3148		
3/16	3/16	2	3/8		0.002			9030920047600	3092		
3/16	3/16	2	5/8		0.002	9031460047600	3146	9031480047600	3148	9038460047600	3846
3/16	3/16	2	5/8	0.015				9030870047620	3087		
3/16	3/16	2	5/8	0.031				9030870047640	3087		
3/16	3/16	2	5/8	0.062				9030870047660	3087		
3/16	3/16	2 1/2	3/4		0.002	9031470047600	3147	9031490047600	3149	9038470047600	3847
13/64	1/4	2 1/2	5/8		0.002	9031460051600	3146	9031480051600	3148		
7/32	1/4	2 1/2	5/8		0.002	9031460055600	3146	9031480055600	3148	9038460055600	3846
15/64	1/4	2 1/2	3/4		0.002	9031460059500	3146	9031480059500	3148		
1/4	1/4	2	1/2		0.004			9030920063500	3092		
1/4	1/4	2 1/2	3/4		0.004	9031460063500	3146	9031480063500	3148	9038460063500	3846
1/4	1/4	2 1/2	3/4	0.015				9030870063520	3087		
1/4	1/4	2 1/2	3/4	0.031				9030870063540	3087		
1/4	1/4	2 1/2	3/4	0.062				9030870063560	3087		
1/4	1/4	3	1 1/8		0.004	9031470063500	3147	9031490063500	3149	9038470063500	3847
1/4	1/4	3	1 1/8	0.015				9030880063520	3088		
1/4	1/4	3	1 1/8	0.031				9030880063540	3088		
1/4	1/4	3	1 1/8	0.062				9030880063560	3088		
17/64	5/16	2 1/2	3/4		0.004	9031460067500	3146	9031480067500	3148		
9/32	5/16	2 1/2	3/4		0.004	9031460071400	3146	9031480071400	3148	9038460071400	3846
19/64	5/16	2 1/2	13/16		0.004	9031460075400	3146	9031480075400	3148		
5/16	5/16	2	1/2		0.004			9030920079400	3092		
5/16	5/16	2 1/2	13/16		0.004	9031460079400	3146	9031480079400	3148	9038460079400	3846
5/16	5/16	2 1/2	13/16	0.015				9030870079420	3087		
5/16	5/16	2 1/2	13/16	0.031				9030870079440	3087		
5/16	5/16	2 1/2	13/16	0.062				9030870079460	3087		

Continued on next page

Uni-Pro 2-flute

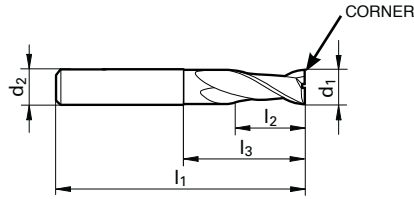

Diameter	Shank Diameter	OAL	LOC	Corner		HA		HA		HA	
				Radius Inch	Chamfer Inch	EDP No. Bright Finish	Series Number	EDP No. FIREX® Coated	Series Number	EDP No. Super-A Coated	Series Number
(d1) Frac	(d2) Frac	(l1) Frac	(l2) Frac								
5/16	5/16	3	1 1/8		0.004	9031470079400	3147	9031490079400	3149	9038470079400	3847
21/64	3/8	2 1/2	1		0.004	9031460083300	3146	9031480083300	3148		
11/32	3/8	2 1/2	1		0.004	9031460087300	3146	9031480087300	3148	9038460087300	3846
23/64	3/8	2 1/2	1		0.004	9031460091300	3146	9031480091300	3148		
3/8	3/8	2	5/8		0.004			9030920095200	3092		
3/8	3/8	2 1/2	1	0.015				9030870095220	3087		
3/8	3/8	2 1/2	1	0.031				9030870095240	3087		
3/8	3/8	2 1/2	1	0.062				9030870095260	3087		
3/8	3/8	2 1/2	1		0.004	9031460095200	3146	9031480095200	3148	9038460095200	3846
3/8	3/8	3	1 1/8	0.015				9030880095220	3088		
3/8	3/8	3	1 1/8	0.031				9030880095240	3088		
3/8	3/8	3	1 1/8	0.062				9030880095260	3088		
3/8	3/8	3	1 1/8		0.004	9031470095200	3147	9031490095200	3149	9038470095200	3847
25/64	7/16	2 1/2	1		0.004	9031460099200	3146	9031480099200	3148		
13/32	7/16	2 3/4	1		0.006	9031460103200	3146	9031480103200	3148	9038460103200	3846
27/64	7/16	2 3/4	1		0.006	9031460107200	3146	9031480107200	3148		
7/16	7/16	2 1/2	5/8		0.006			9030920111100	3092		
7/16	7/16	2 3/4	1		0.006	9031460111100	3146	9031480111100	3148	9038460111100	3846
7/16	7/16	4 1/2	2		0.006	9031470111100	3147	9031490111100	3149	9038470111100	3847
29/64	1/2	3	1		0.006	9031460115100	3146	9031480115100	3148		
15/32	1/2	3	1		0.006	9031460119100	3146	9031480119100	3148	9038460119100	3846
31/64	1/2	3	1		0.006	9031460123000	3146	9031480123000	3148		
1/2	1/2	2 1/2	5/8		0.006			9030920127000	3092		
1/2	1/2	3	1	0.015				9030870127020	3087		
1/2	1/2	3	1	0.031				9030870127040	3087		
1/2	1/2	3	1	0.062				9030870127060	3087		
1/2	1/2	3	1		0.006	9031460127000	3146	9031480127000	3148	9038460127000	3846
1/2	1/2	4 1/2	2	0.015				9030880127020	3088		
1/2	1/2	4 1/2	2	0.031				9030880127040	3088		
1/2	1/2	4 1/2	2	0.062				9030880127060	3088		
1/2	1/2	4 1/2	2		0.006	9031470127000	3147	9031490127000	3149	9038470127000	3847
9/16	9/16	3 1/2	1 1/8		0.006	9031460142900	3146	9031480142900	3148	9038460142900	3846
5/8	5/8	3	3/4		0.006			9030920158700	3092		
5/8	5/8	3 1/2	1 1/4		0.006	9031460158700	3146	9031480158700	3148	9038460158700	3846
5/8	5/8	5	2 1/4		0.006	9031470158700	3147	9031490158700	3149	9038470158700	3847
11/16	3/4	4	1 3/8		0.006	9031460174600	3146	9031480174600	3148	9038460174600	3846
3/4	3/4	3	1		0.006			9030920190500	3092		
3/4	3/4	4	1 1/2		0.006	9031460190500	3146	9031480190500	3148	9038460190500	3846
3/4	3/4	5	2 1/4		0.006	9031470190500	3147	9031490190500	3149	9038470190500	3847
1	1	4	1 1/2		0.012	9031460254000	3146	9031480254000	3148	9038460254000	3846
1	1	5	2 1/4		0.012	9031470254000	3147	9031490254000	3149	9038470254000	3847

Uni-Pro 2-flute

Includes Series

METRIC
3303
3011
3106
3676
3633
3021
3561
3634



TYPE	N
HELIX ANGLE	30°
NUMBER of TEETH	2

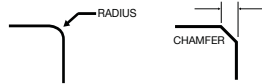
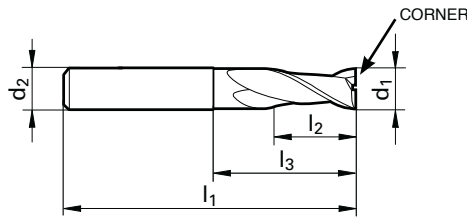

Dia. (d1) mm	Shank Dia. (d2) mm	OAL (l1) mm	LOC (l2) mm	Reach *(l3) mm	Corner		HA		HA		HB	
					Radius mm	Chamfer mm	EDP No. Bright Finish	Series Number	EDP No. FIREX® Coated	Series Number	EDP No. FIREX® Coated	Series Number
2.0	2.0	32	6			0.05	9033030020000	3303	9036760020000	3676		
2.0	6.0	50	3			0.05			9036330030000	3633		
2.5	2.5	32	7			0.05	9033030025000	3303	9036760025000	3676		
2.5	6.0	50	3			0.05			9036330030000	3633		
3.0	3.0	38	7			0.05	9033030030000	3303	9036760030000	3676		
3.0	6.0	50	4			0.05			9036330030000	3633		
3.0	3.0	75	20			0.05	9030110030000	3011	9030210030000	3021		
3.5	3.5	50	7			0.05	9033030035000	3303	9036760035000	3676		
4.0	4.0	50	8			0.05	9033030040000	3303	9036760040000	3676		
4.0	6.0	54	5			0.05			9036330040000	3633		
4.0	4.0	75	25			0.05	9030110040000	3011	9030210040000	3021		
4.5	4.5	50	8			0.05	9033030045000	3303	9036760045000	3676		
5.0	5.0	50	10			0.05	9033030050000	3303	9036760050000	3676		
5.0	6.0	54	6			0.05			9036330050000	3633		
5.0	5.0	75	30			0.05	9030110050000	3011	9030210050000	3021		
5.5	5.5	57	10			0.05	9033030055000	3303	9036760055000	3676		
6.0	6.0	54	7			0.05			9036330060000	3633	9036340060000	3634
6.0	6.0	57	10			0.05	9033030060000	3303	9036760060000	3676		
6.0	6.0	57	10	21	0.5		9031060060050	3106	9035610060050	3561		
6.0	6.0	57	10	21	1.0		9031060060100	3106	9035610060100	3561		
6.0	6.0	75	30			0.05	9030110060000	3011	9030210060000	3021		
6.5	8.0	58	8			0.10			9036330065000	3633		
6.5	6.5	60	13			0.10	9033030065000	3303	9036760065000	3676		
7.0	7.0	60	13			0.10	9033030070000	3303	9036760070000	3676		
7.5	7.5	63	16			0.10	9033030075000	3303	9036760075000	3676		
8.0	8.0	58	9			0.10			9036330080000	3633	9036340080000	3634
8.0	8.0	63	16	27	0.5		9031060080050	3106	9035610080050	3561		
8.0	8.0	63	16	27	1.0		9031060080100	3106	9035610080100	3561		
8.0	8.0	63	16	27	1.5		9031060080150	3106	9035610080150	3561		
8.0	8.0	63	16	27	2.0		9031060080200	3106	9035610080200	3561		
8.0	8.0	63	16			0.10	9033030080000	3303	9036760080000	3676		
8.0	8.0	100	40			0.10	9030110080000	3011	9030210080000	3021		
8.5	8.5	67	16			0.10	9033030085000	3303	9036760085000	3676		
9.0	9.0	67	16			0.10	9033030090000	3303	9036760090000	3676		
9.5	9.5	72	19			0.10	9033030095000	3303	9036760095000	3676		
10.0	10.0	66	11			0.10			9036330100000	3633	9036340100000	3634
10.0	10.0	72	19	32	0.5		9031060100050	3106	9035610100050	3561		
10.0	10.0	72	19	32	1.0		9031060100100	3106	9035610100100	3561		
10.0	10.0	72	19	32	1.5		9031060100150	3106	9035610100150	3561		
10.0	10.0	72	19	32	2.0		9031060100200	3106	9035610100200	3561		
10.0	10.0	72	19			0.10	9033030100000	3303	9036760100000	3676		

* Indicates reduced neck style

Continued on next page

Uni-Pro 2-flute

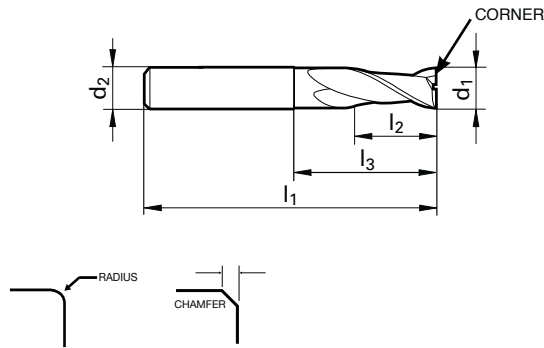

Dia. (d1) mm	Shank Dia. (d2) mm	OAL (l1) mm	LOC (l2) mm	Reach *(l3) mm	Corner		HA		HA		HB	
					Radius mm	Chamfer mm	EDP No. Bright Finish	Series Number	EDP No. FIREX® Coated	Series Number	EDP No. FIREX® Coated	Series Number
10.0	10.0	100	40			0.10	9030110100000	3011	9030210100000	3021		
11.0	11.0	83	22			0.15	9033030110000	3303	9036760110000	3676		
12.0	12.0	73	12			0.15			9036330120000	3633	9036340120000	3634
12.0	12.0	83	22	38		0.5	9031060120050	3106	9035610120050	3561		
12.0	12.0	83	22	38		1.0	9031060120100	3106	9035610120100	3561		
12.0	12.0	83	22	38		1.5	9031060120150	3106	9035610120150	3561		
12.0	12.0	83	22	38		2.0	9031060120200	3106	9035610120200	3561		
12.0	12.0	83	22				9033030120000	3303	9036760120000	3676		
12.0	12.0	150	45				9030110120000	3011	9030210120000	3021		
13.0	13.0	83	22				9033030130000	3303	9036760130000	3676		
14.0	14.0	75	14						9036330140000	3633		
14.0	14.0	83	22				9033030140000	3303	9036760140000	3676		
14.0	14.0	150	45				9030110140000	3011	9030210140000	3021		
14.0	16.0	150	65				9030110140010	3011	9030210140010	3021		
15.0	15.0	92	26				9033030150000	3303	9036760150000	3676		
16.0	16.0	82	16						9036330160000	3633	9036340160000	3634
16.0	16.0	92	26	44		1.0	9031060160100	3106	9035610160100	3561		
16.0	16.0	92	26	44		1.5	9031060160150	3106	9035610160150	3561		
16.0	16.0	92	26	44		2.0	9031060160200	3106	9035610160200	3561		
16.0	16.0	92	26				9033030160000	3303	9036760160000	3676		
16.0	16.0	150	65				9030110160000	3011	9030210160000	3021		
18.0	18.0	84	18						9036330180000	3633		
18.0	18.0	92	26				9033030180000	3303	9036760180000	3676		
18.0	18.0	150	65				9030110180000	3011	9030210180000	3021		
18.0	20.0	150	65				9030110180010	3011	9030210180010	3021		
20.0	20.0	92	20						9036330200000	3633	9036340200000	3634
20.0	20.0	104	32	54		1.0	9031060200100	3106	9035610200100	3561		
20.0	20.0	104	32	54		1.5	9031060200150	3106	9035610200150	3561		
20.0	20.0	104	32	54		2.0	9031060200200	3106	9035610200200	3561		
20.0	20.0	104	32				9033030200000	3303	9036760200000	3676		
20.0	20.0	150	65				9030110200000	3011	9030210200000	3021		

* Indicates reduced neck style

Uni-Pro 3-flute

Includes Series

INCH
3168
3169
3170
3171
3868
3869



TYPE	N
HELIX ANGLE	30°
NUMBER of TEETH	3

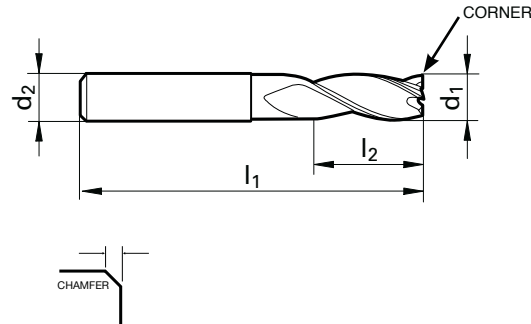

d₁ tolerance h10
 d₂ tolerance h6
 See table on page 150

Diameter (d1) Frac	Shank Diameter (d2) Frac	OAL (l1) Frac	LOC (l2) Frac	Corner Chamfer Inch	HA		HA		HA	
					EDP No. Bright Finish	Series Number	EDP No. FIREX® Coated	Series Number	EDP No. Super-A Coated	Series Number
1/8	1/8	1 1/2	3/8	0.002	9031680031700	3168	9031700031700	3170	9038680031700	3868
3/16	3/16	2	5/8	0.002	9031680047600	3168	9031700047600	3170	9038680047600	3868
3/16	3/16	3	1 1/4	0.002	9031690047600	3169	9031710047600	3171	9038690047600	3869
1/4	1/4	2 1/2	3/4	0.004	9031680063500	3168	9031700063500	3170	9038680063500	3868
1/4	1/4	4	1 5/8	0.004	9031690063500	3169	9031710063500	3171	9038690063500	3869
5/16	5/16	2 1/2	13/16	0.004	9031680079400	3168	9031700079400	3170	9038680079400	3868
5/16	5/16	4	1 5/8	0.004	9031690079400	3169	9031710079400	3171	9038690079400	3869
3/8	3/8	3	1	0.004	9031680095200	3168	9031700095200	3170	9038680095200	3868
3/8	3/8	4	1 5/8	0.004	9031690095200	3169	9031710095200	3171	9038690095200	3869
7/16	7/16	2 3/4	1	0.006	9031680111100	3168	9031700111100	3170	9038680111100	3868
7/16	7/16	5	2	0.006	9031690111100	3169	9031710111100	3171	9038690111100	3869
1/2	1/2	3	1	0.006	9031680127000	3168	9031700127000	3170	9038680127000	3868
1/2	1/2	6	3	0.006	9031690127000	3169	9031710127000	3171	9038690127000	3869
9/16	9/16	3 1/2	1 1/8	0.006	9031680142900	3168	9031700142900	3170	9038680142900	3868
5/8	5/8	3 1/2	1 1/4	0.006	9031680158700	3168	9031700158700	3170	9038680158700	3868
5/8	5/8	6	3	0.006	9031690158700	3169	9031710158700	3171	9038690158700	3869
3/4	3/4	4	1 1/2	0.006	9031680190500	3168	9031700190500	3170	9038680190500	3868
3/4	3/4	6	3	0.006	9031690190500	3169	9031710190500	3171	9038690190500	3869
1	1	4	1 1/2	0.012	9031680254000	3168	9031700254000	3170	9038680254000	3868
1	1	6	3	0.012	9031690254000	3169	9031710254000	3171	9038690254000	3869

Uni-Pro 3-flute

Includes Series

METRIC
3307
3314
3558
3677
3680
3719



TYPE	N
HELIX ANGLE	30°
NUMBER of TEETH	3

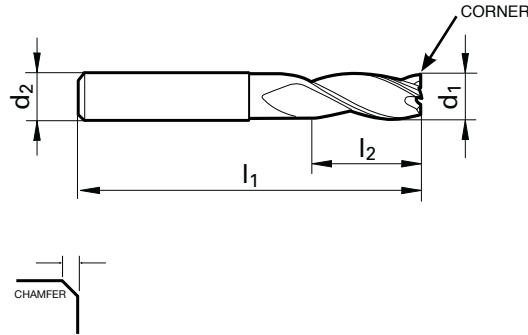

d₁ tolerance h10
 d₂ tolerance h6
 See table on page 150

Dia. (d1) mm	Shank Dia. (d2) mm	OAL (l1) mm	LOC (l2) mm	Corner Chamfer mm	HA		HA		HB	
					EDP No. Bright Finish	Series Number	EDP No. FIREX® Coated	Series Number	EDP No. FIREX® Coated	Series Number
2.0	2.0	32	6	0.05	9033070020000	3307	9036770020000	3677		
2.0	6.0	50	3	0.05			9035580020000	3558	9037190020000	3719
2.5	2.5	32	7	0.05	9033070025000	3307	9036770025000	3677		
2.5	6.0	50	3	0.05			9035580025000	3558	9037190025000	3719
3.0	3.0	38	7	0.05	9033070030000	3307	9036770030000	3677		
3.0	6.0	50	4	0.05			9035580030000	3558	9037190030000	3719
3.0	3.0	75	20	0.05	9033140030000	3314	9036800030000	3680		
3.5	6.0	50	4	0.05			9035580035000	3558	9037190035000	3719
3.5	3.5	50	7	0.05	9033070035000	3307	9036770035000	3677		
4.0	4.0	50	8	0.05	9033070040000	3307	9036770040000	3677		
4.0	6.0	54	5	0.05			9035580040000	3558	9037190040000	3719
4.0	4.0	75	25	0.05	9033140040000	3314	9036800040000	3680		
4.5	4.5	50	8	0.05	9033070045000	3307	9036770045000	3677		
5.0	5.0	50	10	0.05	9033070050000	3307	9036770050000	3677		
5.0	6.0	54	6	0.05			9035580050000	3558	9037190050000	3719
5.0	5.0	75	30	0.05	9033140050000	3314	9036800050000	3680		
5.5	5.5	57	10	0.05	9033070055000	3307	9036770055000	3677		
6.0	6.0	54	7	0.05			9035580060000	3558	9037190060000	3719
6.0	6.0	57	10	0.05	9033070060000	3307	9036770060000	3677		
6.0	6.0	75	30	0.05	9033140060000	3314	9036800060000	3680		
6.5	6.5	60	13	0.10	9033070065000	3307	9036770065000	3677		
7.0	8.0	58	8	0.10			9035580070000	3558	9037190070000	3719
7.0	7.0	60	13	0.10	9033070070000	3307	9036770070000	3677		
7.5	7.5	63	16	0.10	9033070075000	3307	9036770075000	3677		
8.0	8.0	58	9	0.10			9035580080000	3558	9037190080000	3719
8.0	8.0	63	16	0.10	9033070080000	3307	9036770080000	3677		
8.0	8.0	100	40	0.10	9033140080000	3314	9036800080000	3680		
8.5	8.5	67	16	0.10	9033070085000	3307	9036770085000	3677		
9.0	9.0	67	16	0.10	9033070090000	3307	9036770090000	3677		
9.5	9.5	72	19	0.10	9033070095000	3307	9036770095000	3677		
10.0	10.0	66	11	0.10			9035580100000	3558	9037190100000	3719
10.0	10.0	72	19	0.10	9033070100000	3307	9036770100000	3677		
10.0	10.0	100	40	0.10	9033140100000	3314	9036800100000	3680		
11.0	11.0	83	22	0.15	9033070110000	3307	9036770110000	3677		
12.0	12.0	73	12	0.15			9035580120000	3558	9037190120000	3719
12.0	12.0	83	22	0.15	9033070120000	3307	9036770120000	3677		
12.0	12.0	150	45	0.15	9033140120000	3314	9036800120000	3680		
13.0	13.0	83	22	0.15	9033070130000	3307	9036770130000	3677		
14.0	14.0	83	22	0.15	9033070140000	3307	9036770140000	3677		
15.0	15.0	92	26	0.15	9033070150000	3307	9036770150000	3677		

Continued on next page

Uni-Pro 3-flute

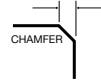
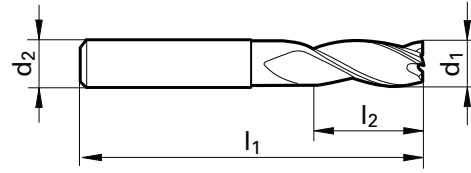

Dia.	Shank Dia.	OAL	LOC	Corner	HA		HA		HB	
(d1) mm	(d2) mm	(l1) mm	(l2) mm	Chamfer mm	EDP No. Bright Finish	Series Number	EDP No. FIREX® Coated	Series Number	EDP No. FIREX® Coated	Series Number
16.0	16.0	82	16	0.15			9035580160000	3558	9037190160000	3719
16.0	16.0	92	26	0.15	9033070160000	3307	9036770160000	3677		
16.0	16.0	150	65	0.15	9033140160000	3314	9036800160000	3680		
18.0	18.0	92	26	0.15	9033070180000	3307	9036770180000	3677		
20.0	20.0	104	32	0.15	9033070200000	3307	9036770200000	3677		
20.0	20.0	150	65	0.15	9033140200000	3314	9036800200000	3680		

Uni-Pro 4-flute

Includes Series



INCH
3089
3090
3093
3150
3151
3152
3153
3155
3156
3850
3851
3852

TYPE	N
HELIX ANGLE	30°
NUMBER OF TEETH	4

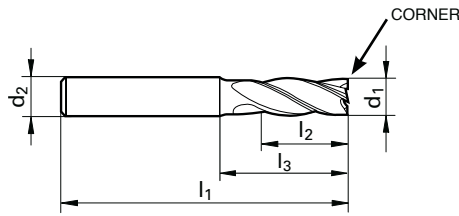

d₁ tolerance h10
d₂ tolerance h6
See table on page 150

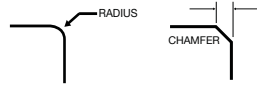

Diameter (d1) Frac	Shank Diameter (d2) Frac	OAL (l1) Frac	LOC (l2) Frac	Corner		Flutes	HA		HA		HA	
				Radius Inch	Chamfer Inch		EDP No. Bright Finish	Series	EDP No. FIREX® Coated	Series	EDP No. Super-A Coated	Series
1/16	1/8	1 1/2	3/16		0.001	4	9031500015900	3150	9031530015900	3153	9038500015900	3850
1/16	1/8	2	1/8		0.001	4			9030930015900	3093		
5/64	1/8	1 1/2	1/4		0.001	4	9031500019800	3150	9031530019800	3153		
3/32	1/8	1 1/2	9/32		0.002	4	9031500023800	3150	9031530023800	3153	9038500023800	3850
7/64	1/8	1 1/2	3/8		0.002	4	9031500027800	3150	9031530027800	3153		
1/8	1/8	1 1/2	3/8		0.002	4	9031500031700	3150	9031530031700	3153	9038500031700	3850
1/8	1/8	1 1/2	3/8	0.015		4			9030890031720	3089		
1/8	1/8	1 1/2	3/8	0.031		4			9030890031740	3089		
1/8	1/8	2	1/4		0.002	4			9030930031700	3093		
1/8	1/8	2	1/2		0.002	4	9031520031700	3152	9031560031700	3156	9038520031700	3852
9/64	3/16	2	1/2		0.002	4	9031500035700	3150	9031530035700	3153		
5/32	3/16	2	1/2		0.002	4	9031500039700	3150	9031530039700	3153	9038500039700	3850
11/64	3/16	2	5/8		0.002	4	9031500043700	3150	9031530043700	3153		
3/16	3/16	2	3/8		0.002	4			9030930047600	3093		
3/16	3/16	2	5/8	0.015		4			9030890047620	3089		
3/16	3/16	2	5/8	0.031		4			9030890047640	3089		
3/16	3/16	2	5/8	0.062		4			9030890047660	3089		
3/16	3/16	2	5/8		0.002	4	9031500047600	3150	9031530047600	3153	9038500047600	3850
3/16	3/16	2 1/2	3/4		0.002	4	9031520047600	3152	9031560047600	3156	9038520047600	3852
3/16	3/16	3	1 1/4		0.002	4	9031510047600	3151	9031550047600	3155	9038510047600	3851
13/64	1/4	2 1/2	5/8		0.002	4	9031500051600	3150	9031530051600	3153		
7/32	1/4	2 1/2	5/8		0.002	4	9031500055600	3150	9031530055600	3153	9038500055600	3850
15/64	1/4	2 1/2	3/4		0.002	4	9031500059500	3150	9031530059500	3153		
1/4	1/4	2	1/2		0.004	4			9030930063500	3093		
1/4	1/4	2 1/2	3/4	0.015		4			9030890063520	3089		
1/4	1/4	2 1/2	3/4	0.031		4			9030890063540	3089		
1/4	1/4	2 1/2	3/4	0.062		4			9030890063560	3089		
1/4	1/4	2 1/2	3/4		0.004	4	9031500063500	3150	9031530063500	3153	9038500063500	3850
1/4	1/4	3	1 1/8		0.004	4	9031520063500	3152	9031560063500	3156	9038520063500	3852
1/4	1/4	4	1 5/8	0.015		4			9030900063520	3090		
1/4	1/4	4	1 5/8	0.031		4			9030900063540	3090		
1/4	1/4	4	1 5/8	0.062		4			9030900063560	3090		
1/4	1/4	4	1 5/8		0.004	4	9031510063500	3151	9031550063500	3155	9038510063500	3851
17/64	5/16	2 1/2	3/4		0.004	4	9031500067500	3150	9031530067500	3153		
9/32	5/16	2 1/2	3/4		0.004	4	9031500071400	3150	9031530071400	3153	9038500071400	3850
19/64	5/16	2 1/2	13/16		0.004	4	9031500075400	3150	9031530075400	3153		
5/16	5/16	2	1/2		0.004	4			9030930079400	3093		
5/16	5/16	2 1/2	13/16		0.004	4	9031500079400	3150	9031530079400	3153	9038500079400	3850
5/16	5/16	2 1/2	13/16	0.015		4			9030890079420	3089		

Continued on next page

Uni-Pro 4-flute

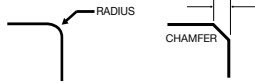
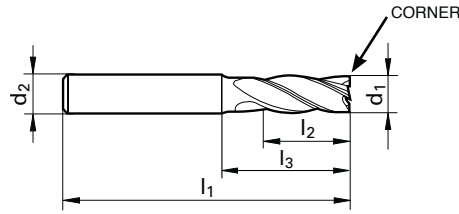

Diameter	Shank Diameter	OAL	LOC	Corner		Flutes	HA		HA		HA	
				Radius Inch	Chamfer Inch		EDP No. Bright Finish	Series	EDP No. FIREX® Coated	Series	EDP No. Super-A Coated	Series
5/16	5/16	2 1/2	13/16	0.031		4			9030890079440	3089		
5/16	5/16	2 1/2	13/16	0.062		4			9030890079460	3089		
5/16	5/16	3	1 1/8		0.004	4	9031520079400	3152	9031560079400	3156	9038520079400	3852
5/16	5/16	4	1 5/8		0.004	4	9031510079400	3151	9031550079400	3155	9038510079400	3851
21/64	3/8	2 1/2	1		0.004	4	9031500083300	3150	9031530083300	3153		
11/32	3/8	2 1/2	1		0.004	4	9031500087300	3150	9031530087300	3153	9038500087300	3850
23/64	3/8	2 1/2	1		0.004	4	9031500091300	3150	9031530091300	3153		
3/8	3/8	2	5/8		0.004	4			9030930095200	3093		
3/8	3/8	2 1/2	1	0.015		4			9030890095220	3089		
3/8	3/8	2 1/2	1	0.031		4			9030890095240	3089		
3/8	3/8	2 1/2	1	0.062		4			9030890095260	3089		
3/8	3/8	2 1/2	1		0.004	4	9031500095200	3150	9031530095200	3153	9038500095200	3850
3/8	3/8	3	1 1/8		0.004	4	9031520095200	3152	9031560095200	3156	9038520095200	3852
3/8	3/8	4	1 5/8	0.015		4			9030900095220	3090		
3/8	3/8	4	1 5/8	0.031		4			9030900095240	3090		
3/8	3/8	4	1 5/8	0.062		4			9030900095260	3090		
3/8	3/8	4	1 5/8		0.004	4	9031510095200	3151	9031550095200	3155	9038510095200	3851
25/64	7/16	2 1/2	1		0.004	4	9031500099200	3150	9031530099200	3153		
13/32	7/16	2 3/4	1		0.006	4	9031500103200	3150	9031530103200	3153	9038500103200	3850
27/64	7/16	2 3/4	1		0.006	4	9031500107200	3150	9031530107200	3153		
7/16	7/16	2 1/2	5/8		0.006	4			9030930111100	3093		
7/16	7/16	2 3/4	1		0.006	4	9031500111100	3150	9031530111100	3153	9038500111100	3850
7/16	7/16	4 1/2	2		0.006	4	9031520111100	3152	9031560111100	3156	9038520111100	3852
7/16	7/16	5	2		0.006	4	9031510111100	3151	9031550111100	3155	9038510111100	3851
29/64	1/2	3	1		0.006	4	9031500115100	3150	9031530115100	3153		
15/32	1/2	3	1		0.006	4	9031500119100	3150	9031530119100	3153	9038500119100	3850
31/64	1/2	3	1		0.006	4	9031500123000	3150	9031530123000	3153		
1/2	1/2	2 1/2	5/8		0.006	4			9030930127000	3093		
1/2	1/2	3	1	0.015		4			9030890127020	3089		
1/2	1/2	3	1	0.031		4			9030890127040	3089		
1/2	1/2	3	1	0.062		4			9030890127060	3089		
1/2	1/2	3	1		0.006	4	9031500127000	3150	9031530127000	3153	9038500127000	3850
1/2	1/2	4 1/2	2		0.006	4	9031520127000	3152	9031560127000	3156	9038520127000	3852
1/2	1/2	6	3	0.015		4			9030900127020	3090		
1/2	1/2	6	3	0.031		4			9030900127040	3090		
1/2	1/2	6	3	0.062		4			9030900127060	3090		
1/2	1/2	6	3		0.006	4	9031510127000	3151	9031550127000	3155	9038510127000	3851
9/16	9/16	3 1/2	1 1/8		0.006	4	9031500142900	3150	9031530142900	3153	9038500142900	3850
5/8	5/8	3	3/4		0.006	4			9030930158700	3093		

Continued on next page

Uni-Pro 4/6-flute

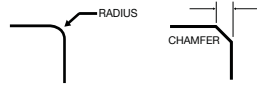
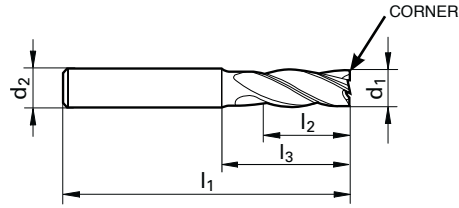

Diameter	Shank Diameter	OAL	LOC	Corner		Flutes	HA		HA		HA	
				Radius Inch	Chamfer Inch		EDP No. Bright Finish	Series	EDP No. FIREX® Coated	Series	EDP No. Super-A Coated	Series
(d1) Frac	(d2) Frac	(l1) Frac	(l2) Frac									
5/8	5/8	3 1/2	1 1/4		0.006	4	9031500158700	3150	9031530158700	3153	9038500158700	3850
5/8	5/8	5	2 1/4		0.006	4	9031520158700	3152	9031560158700	3156	9038520158700	3852
5/8	5/8	6	3		0.006	4	9031510158700	3151	9031550158700	3155	9038510158700	3851
11/16	3/4	4	1 3/8		0.006	4	9031500174600	3150	9031530174600	3153	9038500174600	3850
3/4	3/4	3	1		0.006	4			9030930190500	3093		
3/4	3/4	4	1 1/2		0.006	4	9031500190500	3150	9031530190500	3153	9038500190500	3850
3/4	3/4	5	2 1/4		0.006	4	9031520190500	3152	9031560190500	3156	9038520190500	3852
3/4	3/4	6	3		0.006	4	9031510190500	3151	9031550190500	3155	9038510190500	3851
1	1	4	1 1/2		0.012	6	9031500254000	3150	9031530254000	3153	9038500254000	3850
1	1	5	2 1/4		0.012	6	9031520254000	3152	9031560254000	3156	9038520254000	3852
1	1	6	3		0.012	6	9031510254000	3151	9031550254000	3155	9038510254000	3851

Uni-Pro 4-flute

Includes Series

METRIC
3012
3023
3111
3304
3562
3637
3678
3721



TYPE	N
HELIX ANGLE	30°
NUMBER of TEETH	4

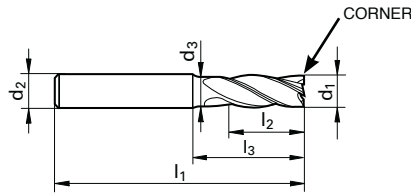

d₁ tolerance h10
d₂ tolerance h6
See table on page 150



Dia. (d1) mm	Shank Dia. (d2) mm	OAL (l1) mm	LOC (l2) mm	Reach *(l3) mm	Corner		HA		HA		HB		
					Radius mm	Chamfer mm	EDP No. Bright Finish	Series Number	EDP No. FIREX® Coated	Series Number	EDP No. FIREX® Coated	Series Number	
2.0	6.0	50	4			0.05				9036370020000	3637	9037210020000	3721
3.0	6.0	50	5			0.05				9036370030000	3637	9037210030000	3721
3.0	3.0	75	20			0.05	9030120030000	3012		9030230030000	3023		
4.0	4.0	50	11			0.05	9033040040000	3304		9036780040000	3678		
4.0	6.0	54	8			0.05				9036370040000	3637	9037210040000	3721
4.0	4.0	75	25			0.05	9030120040000	3012		9030230040000	3023		
4.5	4.5	50	11			0.05	9033040045000	3304		9036780045000	3678		
5.0	5.0	50	13			0.05	9033040050000	3304		9036780050000	3678		
5.0	6.0	54	9			0.05				9036370050000	3637	9037210050000	3721
5.0	5.0	75	30			0.05	9030120050000	3012		9030230050000	3023		
6.0	6.0	54	10			0.05				9036370060000	3637	9037210060000	3721
6.0	6.0	57	13	21	0.5		9031110060050	3111		9035620060050	3562		
6.0	6.0	57	13	21	1.0		9031110060100	3111		9035620060100	3562		
6.0	6.0	57	13				9033040060000	3304		9036780060000	3678		
6.0	6.0	75	30				9030120060000	3012		9030230060000	3023		
7.0	7.0	60	16				9033040070000	3304		9036780070000	3678		
7.5	7.5	63	16				9033040075000	3304		9036780075000	3678		
8.0	8.0	58	12							9036370080000	3637	9037210080000	3721
8.0	8.0	63	19	27	0.5		9031110080050	3111		9035620080050	3562		
8.0	8.0	63	19	27	1.0		9031110080100	3111		9035620080100	3562		
8.0	8.0	63	19	27	1.5		9031110080150	3111		9035620080150	3562		
8.0	8.0	63	19	27	2.0		9031110080200	3111		9035620080200	3562		
8.0	8.0	63	19				9033040080000	3304		9036780080000	3678		
8.0	8.0	100	40				9030120080000	3012		9030230080000	3023		
9.0	9.0	67	19				9033040090000	3304		9036780090000	3678		
10.0	10.0	66	14							9036370100000	3637	9037210100000	3721
10.0	10.0	72	22	32	0.5		9031110100050	3111		9035620100050	3562		
10.0	10.0	72	22	32	0.8		9031110100080	3111		9035620100080	3562		
10.0	10.0	72	22	32	1.0		9031110100100	3111		9035620100100	3562		
10.0	10.0	72	22	32	1.5		9031110100150	3111		9035620100150	3562		
10.0	10.0	72	22	32	2.0		9031110100200	3111		9035620100200	3562		
10.0	10.0	72	22				9033040100000	3304		9036780100000	3678		
10.0	10.0	100	40				9030120100000	3012		9030230100000	3023		
11.0	11.0	83	26				9033040110000	3304		9036780110000	3678		
12.0	12.0	73	16							9036370120000	3637	9037210120000	3721
12.0	12.0	83	26	38	0.5		9031110120050	3111		9035620120050	3562		
12.0	12.0	83	26	38	0.8		9031110120080	3111		9035620120080	3562		
12.0	12.0	83	26	38	1.0		9031110120100	3111		9035620120100	3562		
12.0	12.0	83	26	38	1.5		9031110120150	3111		9035620120150	3562		
12.0	12.0	83	26	38	2.0		9031110120200	3111		9035620120200	3562		

* Indicates reduced neck style

Continued on next page

Uni-Pro 4-flute

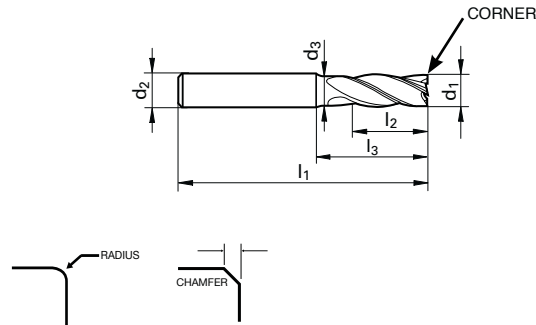

Dia.	Shank Dia.	OAL	LOC	Reach	Corner		HA		HA		HB		
					Radius mm	Chamfer mm	EDP No. Bright Finish	Series Number	EDP No. FIREX® Coated	Series Number	EDP No. FIREX® Coated	Series Number	
12.0	12.0	83	26			0.15		9033040120000	3304	9036780120000	3678		
12.0	12.0	150	45			0.15		9030120120000	3012	9030230120000	3023		
13.0	13.0	83	26			0.15		9033040130000	3304	9036780130000	3678		
14.0	14.0	75	18			0.15				9036370140000	3637	9037210140000	3721
14.0	14.0	83	26			0.15		9033040140000	3304	9036780140000	3678		
14.0	14.0	150	45			0.15		9030120140000	3012	9030230140000	3023		
15.0	15.0	92	32			0.15		9033040150000	3304				
16.0	16.0	82	22			0.15				9036370160000	3637	9037210160000	3721
16.0	16.0	92	32	44	1.0			9031110160100	3111	9035620160100	3562		
16.0	16.0	92	32	44	1.5			9031110160150	3111	9035620160150	3562		
16.0	16.0	92	32	44	2.0			9031110160200	3111	9035620160200	3562		
16.0	16.0	92	32			0.15		9033040160000	3304	9036780160000	3678		
16.0	16.0	150	65			0.15		9030120160000	3012	9030230160000	3023		
18.0	18.0	84	24			0.15				9036370180000	3637	9037210180000	3721
18.0	18.0	92	32			0.15		9033040180000	3304	9036780180000	3678		
18.0	16.0	150	65			0.15		9030120180000	3012	9030230180000	3023		
20.0	20.0	92	26			0.15				9036370200000	3637	9037210200000	3721
20.0	20.0	104	38	54	1.0			9031110200100	3111	9035620200100	3562		
20.0	20.0	104	38	54	1.5			9031110200150	3111	9035620200150	3562		
20.0	20.0	104	38	54	2.0			9031110200200	3111	9035620200200	3562		
20.0	20.0	104	38			0.15		9033040200000	3304	9036780200000	3678		
20.0	20.0	150	65			0.15		9030120200000	3012	9030230200000	3023		

* Indicates reduced neck style

Uni-Pro 2-flute

Ball nose

TYPE	N
HELIX ANGLE	30°
NUMBER of TEETH	2

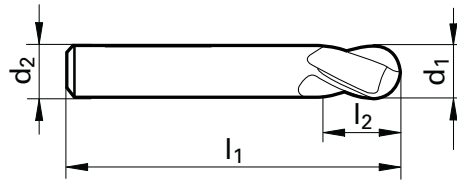

Includes Series
INCH
3157
3158
3159
3160
3857
3858

d₁ tolerance h10
 d₂ tolerance h6
 See table on page 150

Diameter	Shank Diameter	OAL	LOC	HA		HA		HA	
				EDP No. Bright Finish	Series Number	EDP No. FIREX® Coated	Series Number	EDP No. Super-A Coated	Series Number
1/16	1/8	1 1/2	3/16	9031570015900	3157	9031590015900	3159	9038570015900	3857
5/64	1/8	1 1/2	1/4	9031570019800	3157	9031590019800	3159		
3/32	1/8	1 1/2	1/4	9031570023800	3157	9031590023800	3159		
7/64	1/8	1 1/2	3/8	9031570027800	3157	9031590027800	3159		
1/8	1/8	1 1/2	3/8	9031570031700	3157	9031590031700	3159	9038570031700	3857
1/8	1/8	2	1/2	9031580031700	3158	9031600031700	3160	9038580031700	3858
9/64	3/16	2	1/2	9031570035700	3157	9031590035700	3159		
5/32	3/16	2	1/2	9031570039700	3157	9031590039700	3159		
11/64	3/16	2	5/8	9031570043700	3157	9031590043700	3159		
3/16	3/16	2	5/8	9031570047600	3157	9031590047600	3159	9038570047600	3857
3/16	3/16	2 1/2	3/4	9031580047600	3158	9031600047600	3160	9038580047600	3858
13/64	1/4	2 1/2	5/8	9031570051600	3157	9031590051600	3159		
7/32	1/4	2 1/2	5/8	9031570055600	3157	9031590055600	3159		
15/64	1/4	2 1/2	3/4	9031570059500	3157	9031590059500	3159		
1/4	1/4	2 1/2	3/4	9031570063500	3157	9031590063500	3159	9038570063500	3857
1/4	1/4	3	1 1/8	9031580063500	3158	9031600063500	3160	9038580063500	3858
17/64	5/16	2 1/2	3/4	9031570067500	3157	9031590067500	3159		
9/32	5/16	2 1/2	3/4	9031570071400	3157	9031590071400	3159		
19/64	5/16	2 1/2	13/16	9031570075400	3157	9031590075400	3159		
5/16	5/16	2 1/2	13/16	9031570079400	3157	9031590079400	3159	9038570079400	3857
5/16	5/16	3	1 1/8	9031580079400	3158	9031600079400	3160	9038580079400	3858
21/64	3/8	2 1/2	13/16	9031570083300	3157	9031590083300	3159		
11/32	3/8	2 1/2	1	9031570087300	3157	9031590087300	3159		
23/64	3/8	2 1/2	1	9031570091300	3157	9031590091300	3159		
3/8	3/8	2 1/2	1	9031570095200	3157	9031590095200	3159	9038570095200	3857
3/8	3/8	3	1 1/8	9031580095200	3158	9031600095200	3160	9038580095200	3858
25/64	7/16	2 3/4	1	9031570099200	3157	9031590099200	3159		
13/32	7/16	2 3/4	1	9031570103200	3157	9031590103200	3159		
27/64	7/16	2 3/4	1	9031570107200	3157	9031590107200	3159		
7/16	7/16	2 3/4	1	9031570111100	3157	9031590111100	3159	9038570111100	3857
7/16	7/16	4 1/2	2	9031580111100	3158	9031600111100	3160	9038580111100	3858
29/64	1/2	3	1	9031570115100	3157	9031590115100	3159		
15/32	1/2	3	1	9031570119100	3157	9031590119100	3159		
31/64	1/2	3	1	9031570123000	3157	9031590123000	3159		
1/2	1/2	3	1	9031570127000	3157	9031590127000	3159	9038570127000	3857
1/2	1/2	4 1/2	2	9031580127000	3158	9031600127000	3160	9038580127000	3858
9/16	9/16	3 1/2	1 1/8	9031570142900	3157	9031590142900	3159	9038570142900	3857
5/8	5/8	3 1/2	1 1/4	9031570158700	3157	9031590158700	3159	9038570158700	3857
5/8	5/8	5	2 1/4	9031580158700	3158	9031600158700	3160	9038580158700	3858
3/4	3/4	4	1 1/2	9031570190500	3157	9031590190500	3159	9038570190500	3857
3/4	3/4	5	2 1/4	9031580190500	3158	9031600190500	3160	9038580190500	3858
1	1	4	1 1/2	9031570254000	3157	9031590254000	3159		

Uni-Pro 2-flute

Ball nose

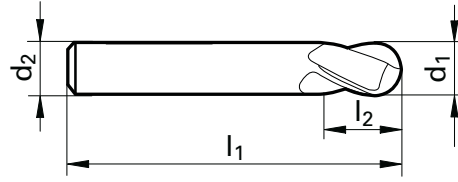
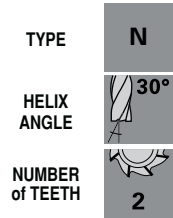

Includes Series	
METRIC	
	3014
	3024
	3030
	3049
	3308
	3679

d_1 tolerance h10
 d_2 tolerance h6
 See table on page 150

Dia. (d1) mm	Shank Dia. (d2) mm	OAL (l1) mm	LOC (l2) mm	Reach *(l3) mm	HA		HA		HB		HB	
					EDP No. Bright Finish	Series Number	EDP No. FIREX® Coated	Series Number	EDP No. Bright Finish	Series Number	EDP No. FIREX® Coated	Series Number
0.5	3.0	38	1		9033080005000	3308	9036790005000	3679				
0.8	3.0	38	1		9033080008000	3308	9036790008000	3679				
1.0	3.0	38	2		9033080010000	3308	9036790010000	3679				
1.5	3.0	38	3		9033080015000	3308	9036790015000	3679				
2.0	6.0	57	6		9033080020000	3308	9036790020000	3679				
3.0	6.0	57	7		9033080030000	3308	9036790030000	3679	9030240030000	3024	9030490030000	3049
3.0	3.0	75	20		9030140030000	3014	9030300030000	3030				
4.0	6.0	57	8		9033080040000	3308	9036790040000	3679	9030240040000	3024	9030490040000	3049
4.0	4.0	75	25		9030140040000	3014	9030300040000	3030				
5.0	6.0	57	10		9033080050000	3308	9036790050000	3679	9030240050000	3024	9030490050000	3049
5.0	5.0	75	30		9030140050000	3014	9030300050000	3030				
6.0	6.0	57	10		9033080060000	3308	9036790060000	3679	9030240060000	3024	9030490060000	3049
6.0	6.0	75	30		9030140060000	3014	9030300060000	3030				
8.0	8.0	63	16		9033080080000	3308	9036790080000	3679	9030240080000	3024	9030490080000	3049
8.0	8.0	100	40		9030140080000	3014	9030300080000	3030				
10.0	10.0	72	19		9033080100000	3308	9036790100000	3679	9030240100000	3024	9030490100000	3049
10.0	10.0	100	40		9030140100000	3014	9030300100000	3030				
12.0	12.0	83	22		9033080120000	3308	9036790120000	3679	9030240120000	3024	9030490120000	3049
12.0	12.0	150	45		9030140120000	3014	9030300120000	3030				
14.0	14.0	83	22		9033080140000	3308	9036790140000	3679	9030240140000	3024	9030490140000	3049
16.0	16.0	92	26		9033080160000	3308	9036790160000	3679	9030240160000	3024	9030490160000	3049
18.0	18.0	92	26		9033080180000	3308	9036790180000	3679	9030240180000	3024	9030490180000	3049
20.0	20.0	104	32		9033080200000	3308	9036790200000	3679	9030240200000	3024	9030490200000	3049

* Indicates reduced neck style

Uni-Pro 4-flute

Ball nose

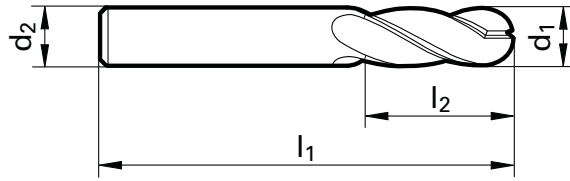

Includes Series	
INCH	
3161	
3162	
3164	
3165	
3166	
3167	
3861	
3862	
3864	

TYPE	N
HELIX ANGLE	30°
NUMBER of TEETH	4

d₁ tolerance h10
 d₂ tolerance h6
 See table on page 150

Diameter	Shank Diameter	OAL	LOC	HA		HA		HA	
				EDP No. Bright Finish	Series Number	EDP No. FIREX® Coated	Series Number	EDP No. Super-A Coated	Series Number
1/16	1/8	1 1/2	3/16	90 3161 001 5900	3161	90 3165 001 5900	3165	9038610015900	3861
5/64	1/8	1 1/2	1/4	90 3161 001 9800	3161	90 3165 001 9800	3165		
3/32	1/8	1 1/2	1/4	90 3161 002 3800	3161	90 3165 002 3800	3165		
7/64	1/8	1 1/2	3/8	90 3161 002 7800	3161	90 3165 002 7800	3165		
1/8	1/8	1 1/2	3/8	90 3161 003 1700	3161	90 3165 003 1700	3165	9038610031700	3861
1/8	1/8	2	1/2	90 3164 003 1700	3164	90 3167 003 1700	3167	9038640031700	3864
9/64	3/16	2	1/2	90 3161 003 5700	3161	90 3165 003 5700	3165		
5/32	3/16	2	1/2	90 3161 003 9700	3161	90 3165 003 9700	3165		
11/64	3/16	2	5/8	90 3161 004 3700	3161	90 3165 004 3700	3165		
3/16	3/16	2	5/8	90 3161 004 7600	3161	90 3165 004 7600	3165	9038610047600	3861
3/16	3/16	2 1/2	3/4	90 3164 004 7600	3164	90 3167 004 7600	3167	9038640047600	3864
3/16	3/16	3	1 1/4	90 3162 004 7600	3162	90 3166 004 7600	3166	9038620047600	3862
13/64	1/4	2 1/2	5/8	90 3161 005 1600	3161	90 3165 005 1600	3165		
7/32	1/4	2 1/2	5/8	90 3161 005 5600	3161	90 3165 005 5600	3165		
15/64	1/4	2 1/2	3/4	90 3161 005 9500	3161	90 3165 005 9500	3165		
1/4	1/4	2 1/2	3/4	90 3161 006 3500	3161	90 3165 006 3500	3165	9038610063500	3861
1/4	1/4	3	1 1/8	90 3164 006 3500	3164	90 3167 006 3500	3167	9038640063500	3864
1/4	1/4	4	1 5/8	90 3162 006 3500	3162	90 3166 006 3500	3166	9038620063500	3862
17/64	5/16	2 1/2	3/4	90 3161 006 7500	3161	90 3165 006 7500	3165		
9/32	5/16	2 1/2	3/4	90 3161 007 1400	3161	90 3165 007 1400	3165		
19/64	5/16	2 1/2	13/16	90 3161 007 5400	3161	90 3165 007 5400	3165		
5/16	5/16	2 1/2	13/16	90 3161 007 9400	3161	90 3165 007 9400	3165	9038610079400	3861
5/16	5/16	3	1 1/8	90 3164 007 9400	3164	90 3167 007 9400	3167	9038640079400	3864
5/16	5/16	4	1 5/8	90 3162 007 9400	3162	90 3166 007 9400	3166	9038620079400	3862
21/64	3/8	2 1/2	1	90 3161 008 3300	3161	90 3165 008 3300	3165		
11/32	3/8	2 1/2	1	90 3161 008 7300	3161	90 3165 008 7300	3165		
23/64	3/8	2 1/2	1	90 3161 009 1300	3161	90 3165 009 1300	3165		
3/8	3/8	2 1/2	1	90 3161 009 5200	3161	90 3165 009 5200	3165	9038610095200	3861
3/8	3/8	3	1 1/8	90 3164 009 5200	3164	90 3167 009 5200	3167	9038640095200	3864
3/8	3/8	4	1 5/8	90 3162 009 5200	3162	90 3166 009 5200	3166	9038620095200	3862
25/64	7/16	2 3/4	1	90 3161 009 9200	3161	90 3165 009 9200	3165		
13/32	7/16	2 3/4	1	90 3161 010 3200	3161	90 3165 010 3200	3165		
27/64	7/16	2 3/4	1	90 3161 010 7200	3161	90 3165 010 7200	3165		
7/16	7/16	2 3/4	1	90 3161 011 1100	3161	90 3165 011 1100	3165	9038610111100	3861
7/16	7/16	4 1/2	2	90 3164 011 1100	3164	90 3167 011 1100	3167	9038640111100	3864
7/16	7/16	5	2	90 3162 011 1100	3162	90 3166 011 1100	3166	9038620111100	3862
29/64	1/2	3	1	90 3161 011 5100	3161	90 3165 011 5100	3165		
15/32	1/2	3	1	90 3161 011 9100	3161	90 3165 011 9100	3165		
31/64	1/2	3	1	90 3161 012 3000	3161	90 3165 012 3000	3165		
1/2	1/2	3	1	90 3161 012 7000	3161	90 3165 012 7000	3165	9038610127000	3861

Continued on next page

Uni-Pro 4-flute

Ball nose

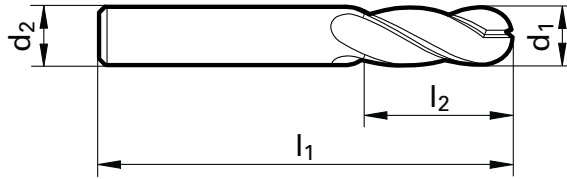

Diameter	Shank Diameter	OAL	LOC	HA		HA		HA	
(d1) Frac	(d2) Frac	(l1) Frac	(l2) Frac	EDP No. Bright Finish	Series Number	EDP No. FIREX® Coated	Series Number	EDP No. Super-A Coated	Series Number
1/2	1/2	4 1/2	2	90 3164 012 7000	3164	90 3167 012 7000	3167	9038640127000	3864
1/2	1/2	6	3	90 3162 012 7000	3162	90 3166 012 7000	3166	9038620127000	3862
9/16	9/16	3 1/2	1 1/8	90 3161 014 2900	3161	90 3165 014 2900	3165	9038610142900	3861
5/8	5/8	3 1/2	1 1/4	90 3161 015 8700	3161	90 3165 015 8700	3165	9038610158700	3861
5/8	5/8	5	2 1/4	90 3164 015 8700	3164	90 3167 015 8700	3167	9038640158700	3864
5/8	5/8	6	3	90 3162 015 8700	3162	90 3166 015 8700	3166	9038620158700	3862
3/4	3/4	4	1 1/2	90 3161 019 0500	3161	90 3165 019 0500	3165	9038610190500	3861
3/4	3/4	5	2 1/4	90 3164 019 0500	3164	90 3167 019 0500	3167	9038640190500	3864
3/4	3/4	6	3	90 3162 019 0500	3162	90 3166 019 0500	3166	9038620190500	3862
1	1	4	1 1/2	90 3161 025 4000	3161	90 3165 025 4000	3165		

METRIC

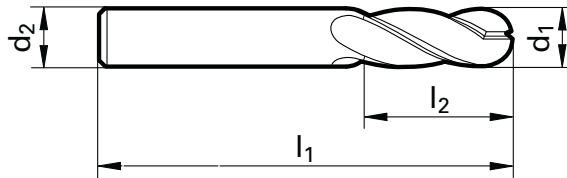

Diameter	Shank Diameter	OAL	LOC	Reach	HA		HA	
(d1) mm	(d2) mm	(l1) mm	(l2) mm	*(l3) mm	EDP No. Bright Finish	Series Number	EDP No. FIREX® Coated	Series Number
3.0	3.0	75	20		90 3015 003 0000	3015	90 3043 003 0000	3043
4.0	4.0	50	11		90 3306 004 0000	3306	90 3727 004 0000	3727
4.0	4.0	75	25		90 3015 004 0000	3015	90 3043 004 0000	3043
5.0	5.0	50	13		90 3306 005 0000	3306	90 3727 005 0000	3727
5.0	5.0	75	30		90 3015 005 0000	3015	90 3043 005 0000	3043
6.0	6.0	57	13		90 3306 006 0000	3306	90 3727 006 0000	3727
6.0	6.0	75	30		90 3015 006 0000	3015	90 3043 006 0000	3043
8.0	8.0	63	19		90 3306 008 0000	3306	90 3727 008 0000	3727
8.0	8.0	100	40		90 3015 008 0000	3015	90 3043 008 0000	3043
10.0	10.0	72	22		90 3306 010 0000	3306	90 3727 010 0000	3727
10.0	10.0	100	40		90 3015 010 0000	3015	90 3043 010 0000	3043
12.0	12.0	83	26		90 3306 012 0000	3306	90 3727 012 0000	3727
12.0	12.0	150	45		90 3015 012 0000	3015	90 3043 012 0000	3043
14.0	14.0	83	26		90 3306 014 0000	3306	90 3727 014 0000	3727
16.0	16.0	92	32		90 3306 016 0000	3306	90 3727 016 0000	3727
18.0	18.0	92	32		90 3306 018 0000	3306	90 3727 018 0000	3727
20.0	20.0	104	38		90 3306 020 0000	3306	90 3727 020 0000	3727

* Indicates reduced neck style

Includes Series
METRIC
3015
3043
3306
3727

TECHNICAL SECTION



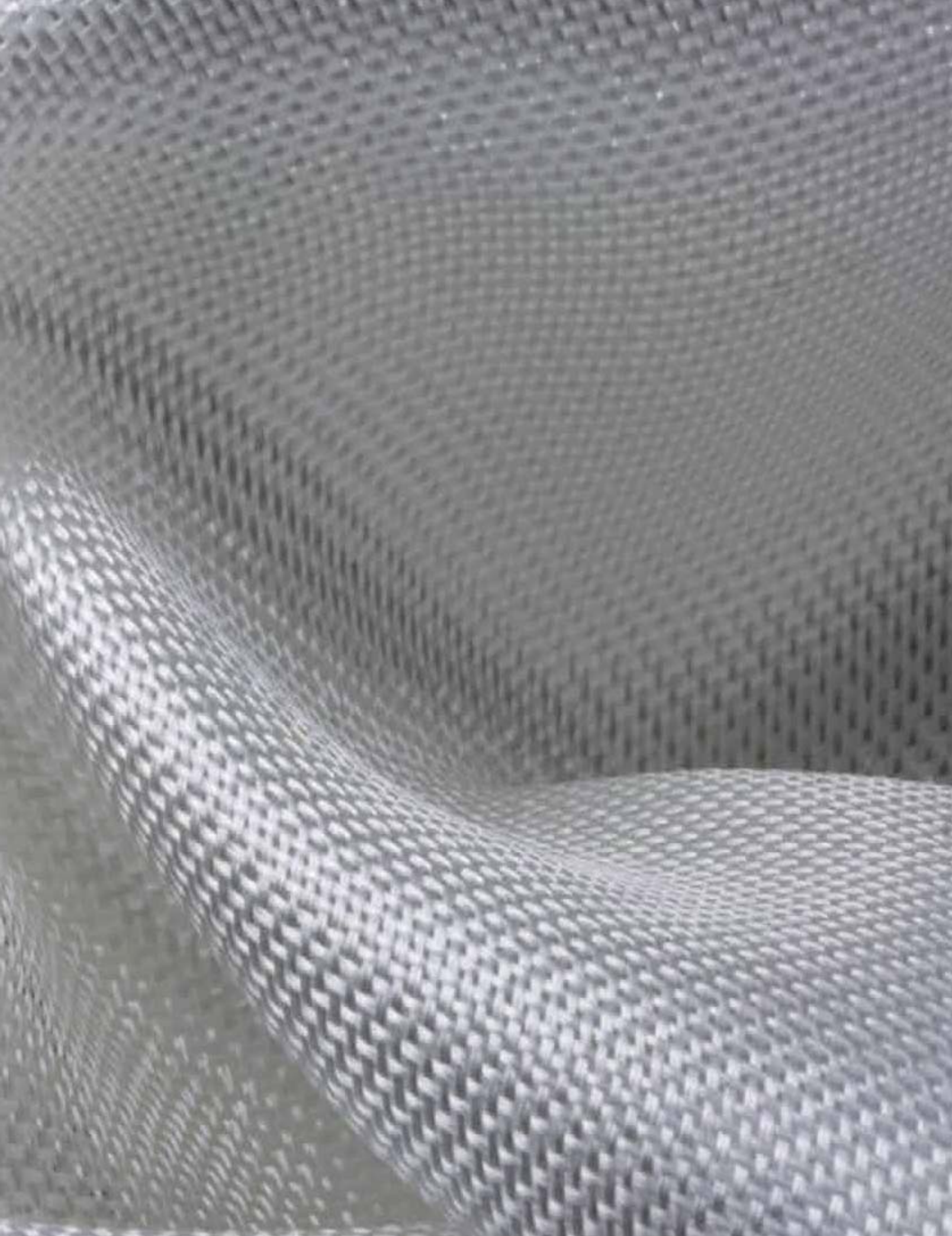

Definitions and angles

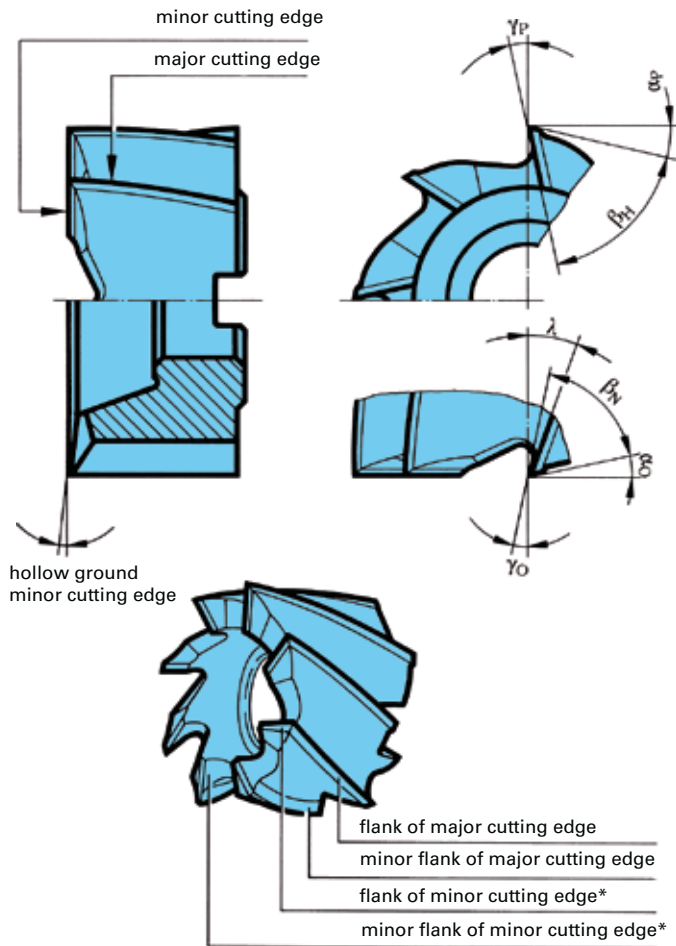

α_P = clearance angle, major cutting edge
 β_H = lip angle, major cutting edge
 γ_P = rake angle, major cutting edge

α_O = clearance angle, minor cutting edge
 β_N = lip angle, minor cutting edge
 γ_O = rake angle, minor cutting edge

λ = spiral angle

*) minor cutting edges do not cut in the direction of feed

Transition angle α and collision angle β with tools $d_1 < d_2$, tapered, dependent on flute and total length.

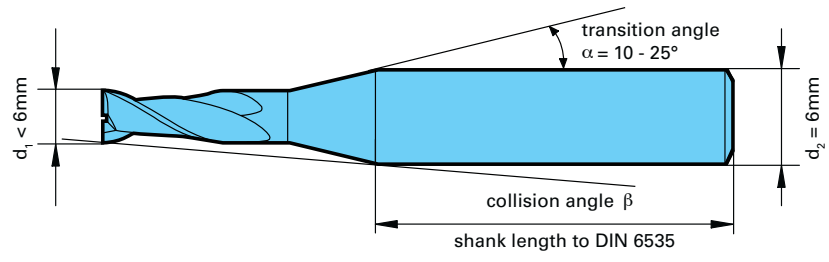

chamfer is measured axially

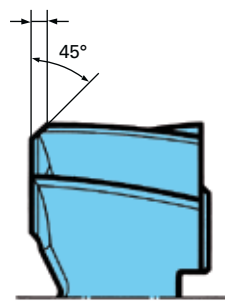

Milling Formulas - INCH Values

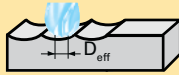
Symbol	Description		Formula
SFM	Surface Feet / Minute		$SFM = \frac{RPM \times D}{3.82}$
RPM	Revolutions / Minute		$RPM = \frac{SFM \times 3.82}{D}$
IPT	Feed / Tooth		$IPT = \frac{IPM}{z \times RPM}$
IPM	Inches / Minute		$IPM = IPT \times RPM \times z$
D _(eff)	Effective Diameter		$D(eff) = 2 \times \sqrt{R^2 - (R - D_1)^2}$

Symbol key: D = tool diameter (in.) z = no. of flutes R = radius D₁ = DOC (ap)

Milling Formulas - METRIC Values

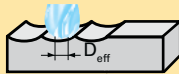
Symbol	Description		Formula
Vc	Surface Meters / Minute		$Vc = \frac{\pi \times D \times n}{1000}$
n	Revolutions / Minute		$n = \frac{Vc \times 1000}{\pi \times D}$
fz	Feed / Tooth		$fz = \frac{vf}{n \times z}$
Vf	Millimeters / Minute		$vf = (n) \times (z) \times (fz)$
D(eff)	Effective Diameter		$D(eff) = 2 \times \sqrt{D \times ap - ap^2}$

Symbol key: π = 3.1416 D = tool diameter (mm) z = no. of flutes ap = depth of cut

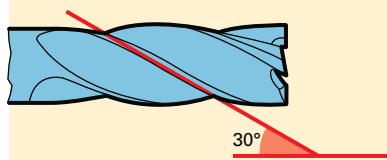

Type N Quick spiral with 30° helical pitch, suitable for finish milling structural, case hardened and heat-treatable steels as well as short-chipping non-ferrous metals and materials up to

- 1200·N/mm²·tensile strength applying high speed steel milling cutters
- 1600·N/mm²·tensile strength applying solid carbide milling cutters

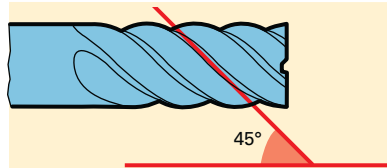

Type NH Quick spiral with high 45° helical pitch, suitable for super fine finishing high-alloyed materials and grey cast iron up to appr.

- 1600·N/mm²·tensile strength

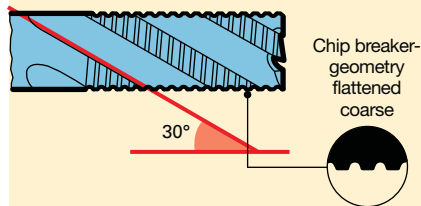

Type NF Flat knuckle-type teeth/quick spiral, produces short chips and improved smoother surface quality in comparison to type NR or NRf. Suitable for milling standard materials up to appr.

- 1200·N/mm²·tensile strength applying high speed steel milling cutters
- 1600·N/mm²·tensile strength applying solid carbide milling cutters

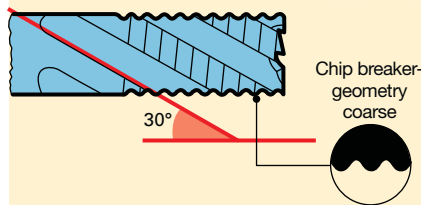

Type NR Standard knuckle-type teeth, produces short chips and good chip evacuation. Suitable for milling standard materials up to appr.

- 1000·N/mm²·tensile strength applying high speed steel milling cutters
- 1200·N/mm²·tensile strength applying solid carbide milling cutters

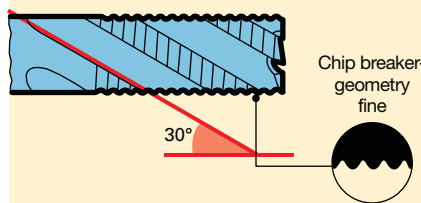

Type NRf Fine knuckle-type teeth, produces short chips and good chip evacuation. Better feed rates possible than with type NR. Suitable for milling materials with a high tensile strength up to appr.

- 1400·N/mm²·tensile strength applying high speed steel milling cutters
- 1600·N/mm²·tensile strength applying solid carbide milling cutters

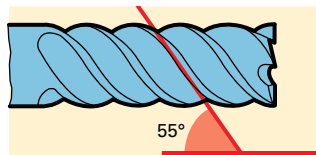

Type H Quick spiral with high 55° helical pitch, suitable for super-fine finishing as well as HSC* machining of all hardened materials and chilled cast iron up to appr.

- 62·HRC hardness

* High Speed Cutting

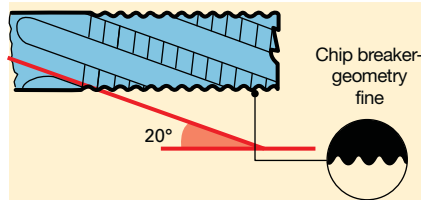

Type HR Fine knuckle-type teeth, produces short chips with good chip evacuation. Suitable for milling hardened materials as well as grey and chilled cast iron with up to appr.

- 56 HRC hardness

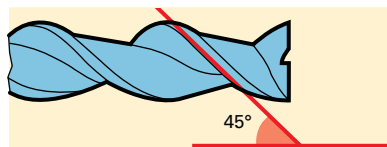

Type W Quick spiral with 45° helical pitch, suitable for finish milling soft materials such as aluminium, Al-alloys and non-ferrous metals up to appr.

- 600 N/mm² tensile strength

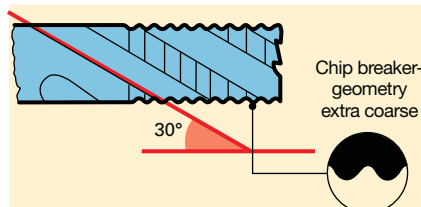

Type WR Coarse knuckle-type teeth, produces short chips with good chip evacuation. Suitable for milling aluminium, non-ferrous metals as well as soft steels up to appr.

- 600 N/mm²·tensile strength.

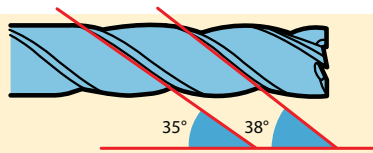

**RF 100 U
(type N)**

35°/38° helix. Suitable for slotting, roughing and finishing steel, high-alloyed steel and hardened steel up to
 • 1600 N/mm² tensile strength (48 HRC)

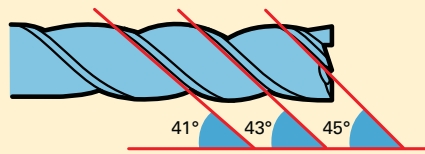

**RF 100 U
(type N)
3-fluted**

41°/43°/45° helix. Suitable for slotting, roughing and finishing steel, high-alloyed steel and hardened steel up to
 • 1400 N/mm² tensile strength (44 HRC)
 3-fluted suitable for extreme cutting depths

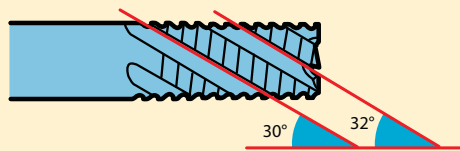

**RF 100 U/HF
(type HF)**

30°/32° helix and roughing geometry. Suitable for slotting and roughing with large cutting widths and depths in steel, high-alloyed steel and hardened steel up to
 • 1600 N/mm² tensile strength (48 HRC)

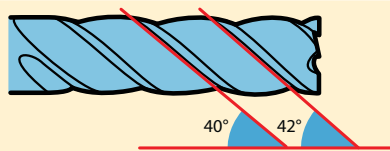

**RF 100 F
(type NH)**

40°/42° helix. Suitable for slotting, roughing and finishing soft and tough steels as well as other long-chipping materials up to
 • 850 N/mm² tensile strength (25 HRC)

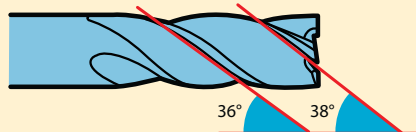

**RF 100 VA
(type N)**

36°/38° helix. Suitable for slotting, roughing and finishing VA steels and stainless materials

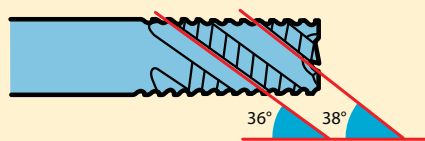

**RF 100 VA/NF
(type NF)**

36°/38° helix and roughing geometry. Suitable for slotting and roughing VA steels and stainless materials

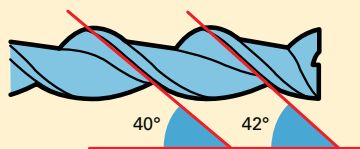

**RF 100 A
(type W)**

40°/42° helix. Suitable for slotting, roughing and finishing aluminium and Al-alloys as well as long-chipping materials and non-ferrous metals

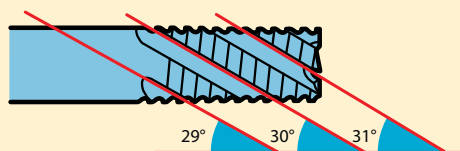

**RF 100 A/WF
(type WF)**

29°/30°/31° helix and roughing geometry. Suitable for slotting and roughing aluminium and Al-alloys

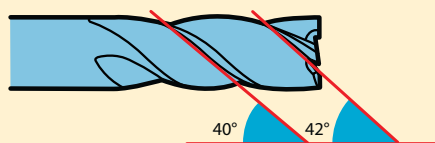

**RF 100 H
(type H)**

40°/42° helix and progressive core diameter. Suitable for roughing up to 1xD in materials up to 54 HRC, for finishing over the entire cutting edge length in materials up to 60 HRC. With HPC strategy suitable for roughing materials > 60 HRC.

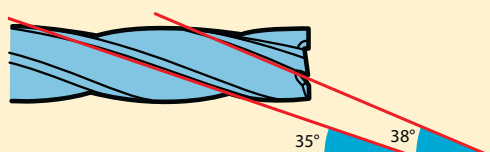

**RF 100 Ti
(type N)**

35°/38° helix with corner radius. Suitable for slotting and roughing of titanium alloys

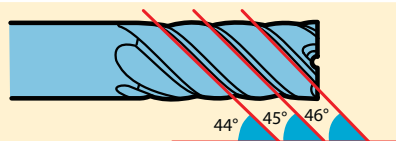

**RF 100 SF
(type NH)**

44°/45°/46° helix. Suitable for HSC super fine finishing for semi-roughing with feed widths up to max. 0.3xD and HPC roughing over the entire cutting edge length for standard steels, cast iron, non-ferrous metals and high-alloyed materials

Comparison of Hardness

Tens. strength (N/mm ²)	HRC	HB30	HV10
240		71	75
255		76	80
270		81	85
285		86	90
305		90	95
320		95	100
335		100	105
350		105	110
370		109	115
385		114	120
400		119	125
415		124	130
430		128	135
450		133	140
465		138	145
480		143	150
495		147	155
510		152	160
530		157	165
545		162	170
560		166	175
575		171	180
595		176	185
610		181	190
625		185	195
640		190	200
660		195	205
675		199	210
690		204	215
705		209	220
720		214	225
740		219	230
755		223	235
770		228	240
785		233	245
800	22	238	250
820	23	242	255
835	24	247	260
860	25	255	268
870	26	258	272
900	27	266	280
920	28	273	287

Tens. strength (N/mm ²)	HRC	HB30	HV10
940	29	278	293
970	30	287	302
995	31	295	310
1020	32	301	317
1050	33	311	327
1080	34	319	336
1110	35	328	345
1140	36	337	355
1170	37	346	364
1200	38	354	373
1230	39	363	382
1260	40	372	392
1300	41	383	403
1330	42	393	413
1360	43	402	423
1400	44	413	434
1440	45	424	446
1480	46	435	458
1530	47	449	473
1570	48	460	484
1620	49	472	497
1680	50	488	514
1730	51	501	527
1790	52	517	544
1845	53	532	560
1910	54	549	578
1980	55	567	596
2050	56	584	615
2140	57	607	639
2180	58	622	655
	59		675
	60		698
	61		720
	62		745
	63		773
	64		800
	65		829
	66		864
	67		900
	68		940

Tolerances to DIN ISO 286

		Nominal diameter range in µm/tolerances in µm										
		from 1 up to 3	over 3 up to 6	over 6 up to 10	over 10 up to 18	over 18 up to 30	over 30 up to 50	over 50 up to 80	over 80 up to 120	over 120 up to 180	over 180 up to 250	
Tolerances: Position and Grade	Shafts	h 6	0	0	0	0	0	0	0	0	0	0
			-6	-8	-9	-11	-13	-16	-19	-22	-25	-29
		h 7	0	0	0	0	0	0	0	0	0	0
			-10	-12	-15	-18	-21	-25	-30	-35	-40	-46
		h 8	0	0	0	0	0	0	0	0	0	0
			-14	-18	-22	-27	-33	-39	-46	-54	-63	-72
		h 9	0	0	0	0	0	0	0	0	0	
			-25	-30	-36	-43	-52	-62	-74	-87	-100	-115
		h 10	0	0	0	0	0	0	0	0	0	0
			-40	-48	-58	-70	-84	-100	-120	-140	-160	-185
		e 8*	-14	-20	-25	-32	-40	-50	-60	-72	-85	-100
			-28	-38	-47	-59	-73	-89	-106	-126	-148	-172

*Milling cutters to tolerance e8 produce key slots to tolerance P9 with one cut.

General notes

All the cutting rate recommendations specified in this catalog are standard values valid exclusively for new tools or tools re-ground to Guhring specifications. Pre-requisites are stable machines, optimal cooling, optimal tool clamping and maximum concentricity of the tool and the machine

spindle. Our recommended cutting rates must be reduced if the conditions deviate. The values may also be adjusted to influence Surface finish quality, machining rate or tool life.

1. Workpiece clamping

Loss of tool life or tool breakage through unstable clamping

- improve workpiece clamping

Alternative:

- reduce feed
- reduce cutting width or depth

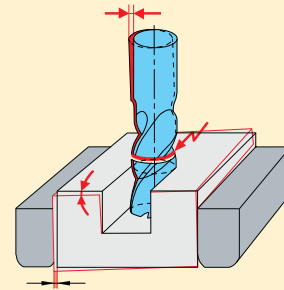

2. Tool clamping

Loss of tool life or tool breakage through unstable, worn or too small/long/thin tool holder

- apply new or larger tool holder or holder with increased clamping force and increased concentricity

Alternative:

- reduce cutting rates
- reduce clamping length
- apply tool with smaller diameter
- check clamping screws for wear

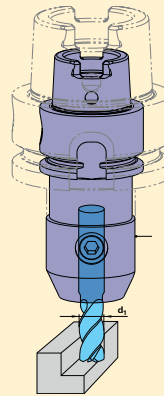

3. Surface finish quality

Excessive peak-to-valley height R_a/R_z at the tool Surface finish through excessive feed rates or vibrations

- improve workpiece clamping and tool clamping (see points 1 and 2)

Alternative:

- reduce feed and feed rate
- increase cutting speed

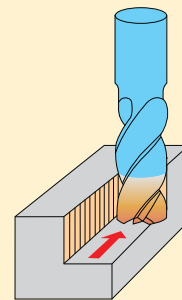

4. Vibrations

High tool wear, insufficient workpiece Surface finish quality and insufficient dimensional accuracy through vibration

- improve workpiece and tool clamping (see points 1 and 2)
- increase tooth feed, because the chip centre thickness is too small
- modify speed
- modify milling strategy, i.e. select alternative cutting distribution
- change tool selection, i.e. reduce no. of teeth or spiral

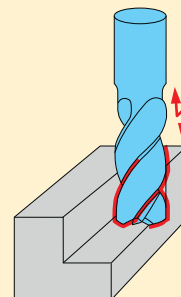

5. Chip congestion/cooling

Significant reduction in tool life, chipping on cutting edges, edge build-up of flutes through insufficient chip evacuation

- select milling cutters with internal cooling

Alternative:

- peripheral cooling via GM 300 chuck
- increase volume flow
- adjust coolant flow
- apply compressed air cooling (according to tool and material)
- reduce feed rate
- modify cutting distribution
- select end mill with fewer flutes

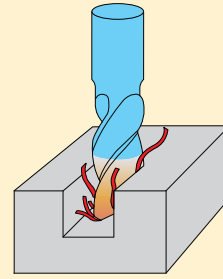

6. Pecking when drilling

Significant reduction in tool life as well as chipping of cutting edges through insufficient chip evacuation and thermal stresses

- select milling cutter with internal cooling with drilling depths $> 0.5 \times D$ pecking in stages

Alternative:

- peripheral cooling via GM 300 chuck
- increase volume flow
- adjust coolant flow
- reduce feed rate

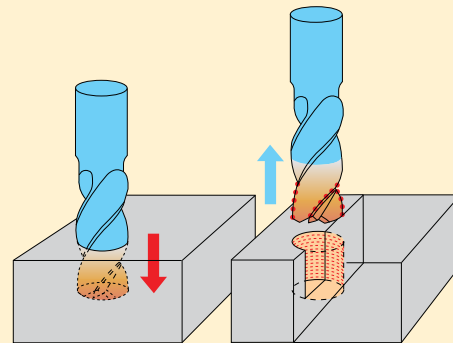

7. Thermal influence on materials

Through welding or torch cutting, the material characteristics at the parting line do not correspond with the specified material class

- reduce cutting rates
- select tool for materials with a higher tensile strength

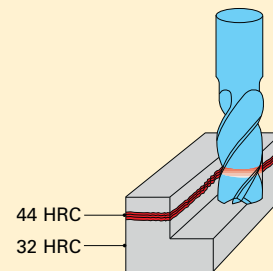

8. Entry in hardened materials

For entering materials over 44 HRC, reduce the feed rate IPT in accordance with the illustration on the right

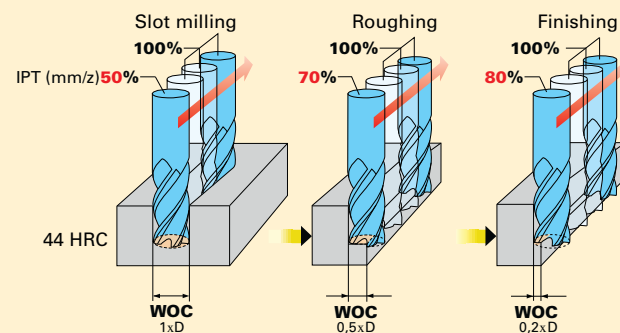

Troubleshooting

9. Loss in tool life with interrupted cutting

Significant loss in tool life through interrupted cutting (especially with milling angles of 90°)

- modify cutting distribution
- reduce feed rate for entry and exit
- reduce approach angle

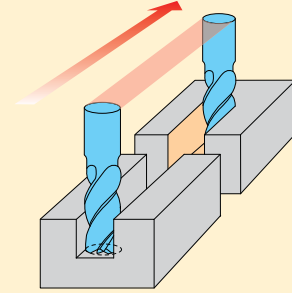

10. Feed rate adjustment: Modifying the cutting depth

- when modifying the cutting depth DOC, the feed rate must be reduced in accordance with the illustration on the right
- cutting speed or revolutions remain unchanged up to cutting depths of 3 x D, must only be adapted over 3 x D

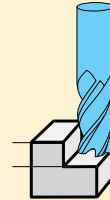

DOC = 1 x D
IPT = 100 %

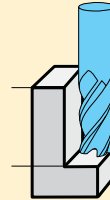

DOC = 2 x D
IPT = 50 %

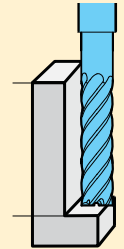

DOC = 3 x D
IPT = 25 %

11. Plunging strategies

for drilling:

- reduce feed rate IPT
- additional pecking for drilling depths > 0.5 x D or transition to radial machining

Attention: Danger of breakage through abrupt load increase!

Ramping up to 15° (preferred):

- reduction in feed rate IPT not required

Ramping between 15° and 30°:

- reduce feed rate IPT in accordance with the illustration on the right

Helical plunging:

- for helical plunging on a milling cycle, we recommend a feed of 0.1 to 0.2 per cycle (0.100" - 0.200")
- reduce feed rate IPT in accordance with the illustration on the right
- select preferred hole diameter 1.8 x D

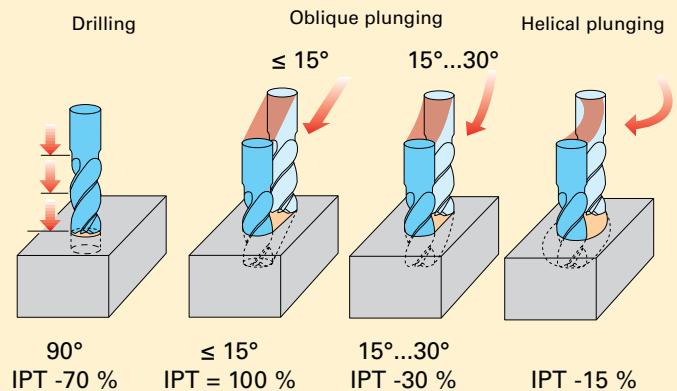

12. Copy milling

For cutting depths $DOC < 0.5 \times D$, the engaged effective diameter D_{eff} must be applied to calculate the speed. With the spindle not engaged, the effective diameter is calculated according to the illustration below. To increase tool life, we recommend machining with tilted spindle. The tilt angle must be taken into account when calculating the effective diameter D_{eff} .

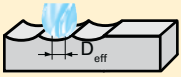

$$D_{(eff)} = 2 \cdot \sqrt{D \cdot DOC - DOC^2}$$

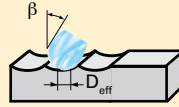

$$D_{(eff)} = D \cdot \sin \left[\beta + \arccos \left(\frac{D - 2DOC}{D} \right) \right]$$

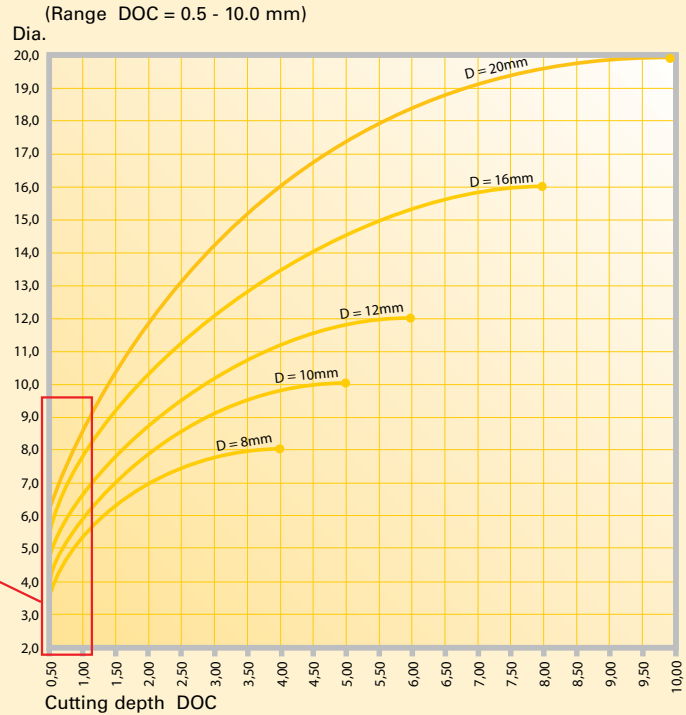
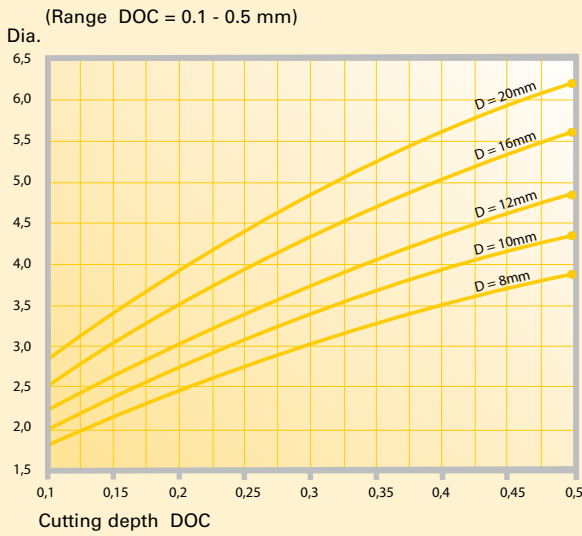

Modifying the cutting width WOC results in improved Surface finish quality of the workpiece (reduced peak-to-valley height)

$$R_{th} = \frac{D}{2} - \sqrt{\frac{D^2 - WOC^2}{4}}$$

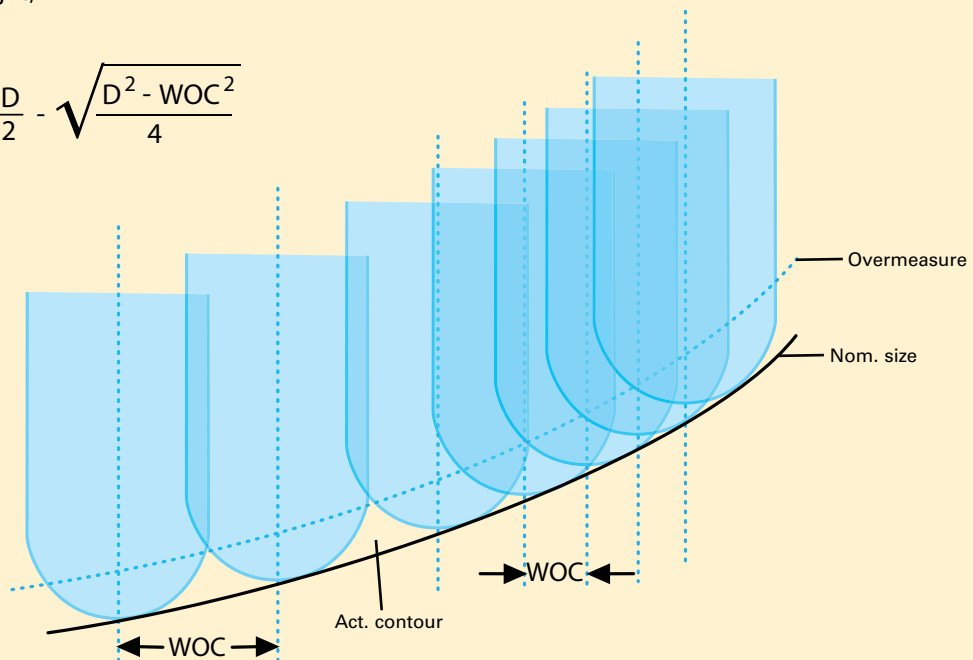

FEEDS & SPEEDS FOR ALL RF100 (variable helix) Normal & Rougher

$$RPM = \frac{SFM}{d_1} \times 3.82 \quad IPM = \text{No. of teeth} \times IPT \times RPM$$

Example - Adjusting SFM and IPT for
1/2" diameter end mill, WOC .050", material 1018

SFM **IPT**
WOC / d1 = xx% WOC 10%
.050 / .500 = 10% 10% = 1.8 IPT multiplier
WOC = 10% IPT .0026 x 1.8 = .0047
SFM = 1350 **IPT = .0047**

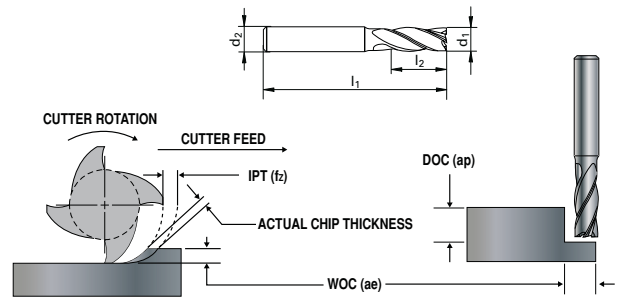

If surface finish is the priority use IPT from table with no adjustment for chip thinning. Use SFM for 10% radial width of cut.

Material	Color Code	Hardness	RF100	Surface Feet per Minute - SFM					Feed Rate Inch per Tooth - IPT							
				Radial Width of Cut WOC (ae)					d1 End Mill Diameter							
				5%	10%	30%	50%	100% Slotting	1/8	1/4	5/16	3/8	1/2	5/8	3/4	1
				2.3	1.8	1.1	1	1	Multiply IPT x this factor based on WOC							
Free Machining & Low Carbon Steels 1006, 1008, 1015, 1018, 1020, 1022, 1025, 1117, 1140, 1141, 11L08, 11L14, 1213, 12L13, 12L14, 1215, 1330	GREEN	up to 28 HRc	F VA SF	1700	1350	750	425	425	.0006	.0014	.0018	.0022	.0026	.0030	.0040	.0047
Medium Carbon & High Carbon Steels, Alloy Steels & Easy to Machine Tool Steels 1030, 1035, 1040, 1045, 1050, 1052, 1055, 1060, 1085, 1095, 1541, 1551, 9255, 2515, 3135, 3415, 4130, 4137, 4140, 4150, 4320, 4340, 4520, 5015, 5115, 5120, 5132, 5140, 5155, 6150, 8620, 9262, 9840, 52100, O1, O2, O6, S2, W1 to W310	GREEN RED	28 to 38 HRc	U F SF	900	625	350	275	275	.0006	.0014	.0018	.0022	.0026	.0030	.0040	.0047
Tool Steels & Die Steels O7, M1, M2, M3, M4, M7, T1, T2, T4, T5, T8, T15, A2, A3, A6, A7, H10, H11, H12, H13, H19, H21, L3, L6, L7, P2, P20, S1, S5, S7, 52100, A 128, D2, D3, D4, D5, D7	RED	28 to 44 HRc	U U SF	550	450	300	200	200	.0005	.0012	.0015	.0018	.0022	.0026	.0034	.0038
Hardened Steels Carbon and Alloy Steels, Tool & Die Steels	H H	Up to 54 HRc 54 to 60 HRc	U SF H	325 200					.0003 .0002	.0007 .0004	.0010 .0007	.0012 .0010	.0015 .0012	.0020 .0017	.0024 .0020	.0030 .0025
Stainless Steel - Easy to Machine 430F, 301, 303, 410, 416 Annealed, 420F, 430, 430F	BLUE	Up to 28 HRc	VA VA SF	1050	725	400	325	325	.0006	.0014	.0018	.0022	.0026	.0030	.0040	.0047
Stainless Steel - Moderately Difficult 301, 302, 303 High Tensile, 304, 304L, 305, 420, 15-5PH, 17-4PH, 17-7PH	BLUE	up to 28 HRc	VA VA SF	650	450	250	200	200	.0005	.0012	.0015	.0018	.0022	.0026	.0030	.0037
Stainless Steel - Difficult to Machine 302B, 304B, 309, 310, 316, 316B, 316L, 316Ti, 317, 317L, 321, PH13-8MO, Nitronic	BLUE	over 28 HRc	VA/F VA/F SF	600	400	225	175	175	.0005	.0010	.0012	.0016	.0018	.0024	.0028	.0037
High-Temperature Alloys Nimonic, Inconel, Monel, Hastelloy	GRAY	up to 42 HRc	Ti/F VA SF	120	120	120	100	100	.0003	.0007	.0010	.0012	.0015	.0020	.0024	.0030
Titanium Alloys 6Al-4V, 5Al-2.5 Sn, 6Al-2Sn-4Zr-6Mo, 3Al-6V-6Cr-4Mo-4Zr, 10V-2Fe-3Al, 13V-11Cr-3Al	GRAY	up to 42 HRc	Ti/U VA SF	350	300	250	150	150	.0005	.0012	.0015	.0018	.0022	.0028	.0035	.0040
Cast Iron - Gray CG ASTM A48, CLASS 20, 25, 30, 35, SAE J431C, GRADES G1800, G3000, G3500, GG 10, 15, 20, 25, 30, 35, 40	WHITE	up to 240 HB 30	F U SF	1300	1100	750	375	375	.0006	.0014	.0018	.0022	.0026	.0030	.0040	.0047
Cast Iron - Ductile & Malleable CGI 60-40-18, 65-45-12, D4018, D4512, D5506, 32510, 35108, M3210, M4504, M5503, 250, 300, 350, 400, 450	WHITE	over 240 HB 30	U VA SF	900	625	400	275	275	.0006	.0014	.0018	.0022	.0026	.0030	.0040	.0047
Aluminum, Al-wrought alloys, Al-alloys 2024, 6061, 7075, 1050, 6351, 5005, 2017, 7075	BLACK	up to 3% Si	A	1500	1500	1500	1000	1000	.0010	.0023	.0029	.0035	.0045	.0058	.0068	.0090
Aluminum-cast alloys High Silicon - A380, A390, Castings, 3.2131 G-ALSi-5Cu1, 3.2153 G-ALSi7Cu3, 3.2573 G-ALSi9, 3.2581 G-ALSi12, 3.2583 G-ALSi12Cu, - G-ALSi12CuNiMg	BLACK	over 3% Si	A	1500	1500	1200	700	700	.0008	.0018	.0023	.0028	.0036	.0046	.0054	.0072
Magnesium Alloys	PURPLE	—	A F SF	2100	1500	800	650	650	.0006	.0015	.0019	.0022	.0029	.0037	.0044	.0058
Non-ferrous Copper Alloys, Brass, Bronze	BROWN	up to 28 HRc	A F SF	1500	1000	575	450	450	.0005	.0010	.0014	.0018	.0021	.0028	.0033	.0046

FEEDS & SPEEDS FOR ALL Tech Line - Normal & Rougher

$$RPM = \frac{SFM}{d_1} \times 3.82 \quad IPM = \text{No. of teeth} \times IPT \times RPM$$

Example - Adjusting SFM and IPT for
 1/2" diameter end mill, WOC .050", material 1018

SFM **IPT**
 WOC / d1 = xx% WOC 10%
 .050 / .500 = 10% 10% = 1.8 IPT multiplier
 WOC = 10% IPT .0026 x 1.8 = .0047
SFM = 1350 **IPT = .0047**

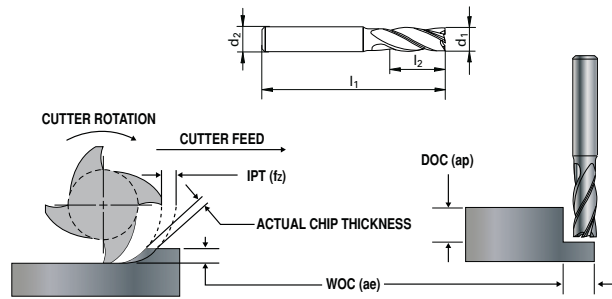

If surface finish is the priority use IPT from table with no adjustment for chip thinning. Use SFM for 10% radial width of cut.

Material	Color Code	Hardness	Tech-Line	Surface Feet per Minute - SFM					Feed Rate Inch per Tooth - IPT							
				Radial Width of Cut WOC (ae)					d1 End Mill Diameter							
				5%	10%	30%	50%	100% Slotting	1/8	1/4	5/16	3/8	1/2	5/8	3/4	1
				2.3	1.8	1.1	1	1	Multiply IPT x this factor based on WOC							
Free Machining & Low Carbon Steels 1006, 1008, 1015, 1018, 1020, 1022, 1025, 1117, 1140, 1141, 11L08, 11L14, 1213, 12L13, 12L14, 1215, 1330	GREEN	up to 28 HRc	GH 100 U RS 100 U GS 100 U	1700	1350	750	425	425	.0005	.0013	.0016	.0020	.0023	.0027	.0036	.0042
Medium Carbon & High Carbon Steels, Alloy Steels & Easy to Machine Tool Steels 1030, 1035, 1040, 1045, 1050, 1052, 1055, 1060, 1085, 1095, 1541, 1551, 9255, 2515, 3135, 3415, 4130, 4137, 4140, 4150, 4320, 4340, 4520, 5015, 5115, 5120, 5132, 5140, 5155, 6150, 8620, 9262, 9840, 52100, O1, O2, O6, S2, W1 to W310	GREEN RED	28 to 38 HRc	GH 100 U RS 100 U GS 100 U	900	625	350	275	275	.0005	.0013	.0016	.0020	.0023	.0027	.0036	.0042
Tool Steels & Die Steels O7, M1, M2, M3, M4, M7, T1, T2, T4, T5, T8, T15, A2, A3, A6, A7, H10, H11, H12, H13, H19, H21, L3, L6, L7, P2, P20, S1, S5, S7, 52100, A 128, D2, D3, D4, D5, D7	RED	28 to 44 HRc	GH 100 U RS 100 F GS 100 H	550	450	300	200	200	.0005	.0011	.0014	.0016	.0020	.0023	.0031	.0034
Hardened Steels Carbon and Alloy Steels, Tool & Die Steels	H H	up to 54 HRc 54 to 60 HRc	GH 100 U GS 100 H GH 100 H	325 200	0 0	0 0	0 0	0	.0003 .0002	.0006 .0004	.0009 .0006	.0011 .0009	.0014 .0011	.0018 .0015	.0022 .0018	.0027 .0023
Stainless Steel - Easy to Machine 430F, 301, 303, 410, 416 Annealed, 420F, 430, 430F	BLUE	up to 28 HRc	GH 100 U RS 100 U GS 100 U	1050	725	400	325	325	.0005	.0013	.0016	.0020	.0023	.0027	.0036	.0042
Stainless Steel - Moderately Difficult 301, 302, 303 High Tensile, 304, 304L, 305, 420, 15-5PH, 17-4PH, 17-7PH* 28 HRc	BLUE	up to 28 HRc	GH 100 U RS 100 U GS 100 U	650	450	250	200	200	.0005	.0011	.0014	.0016	.0020	.0023	.0027	.0033
Stainless Steel - Difficult to Machine 302B, 304B, 309, 310, 316, 316B, 316L, 316Ti, 317, 317L, 321, PH13-8MO, Nitronic* 28 HRc	BLUE	over 28 HRc	GH 100 U RS 100 U GS 100 U	600	400	225	175	175	.0005	.0009	.0011	.0014	.0016	.0022	.0025	.0033
High-Temperature Alloys Nimonic, Inconel, Monel, Hastelloy	GRAY	up to 42 HRc	GH 100 U GH 100 H RS 100 F	120	120	120	100	100	.0003	.0006	.0009	.0011	.0014	.0018	.0022	.0027
Titanium Alloys 6Al-4V, 5Al-2.5 Sn, 6Al-2Sn-4Zr-6Mo, 3Al-8V-6Cr4Mo-4Zr, 10V-2Fe-3Al, 13V-11Cr-3Al	GRAY	up to 42 HRc	GH 100 U RS 100 U RS 100 F	350	300	250	150	150	.0005	.0011	.0014	.0016	.0020	.0025	.0032	.0036
Cast Iron - Gray CG ASTM A48, CLASS 20, 25, 30, 35, SAE J431C, GRADES G1800, G3000, G3500, GG 10, 15, 20, 25, 30, 35, 40	WHITE	up to 240 HB 30	GH 100 U GS 100 H RS 100 F	1300	1100	750	375	375	.0005	.0013	.0016	.0020	.0023	.0027	.0036	.0042
Cast Iron - Ductile & Malleable CGI 60-40-18, 65-45-12, D4018, D4512, D5506, 32510, 35108, M3210, M4504, M5503, 250, 300, 350, 400, 450	WHITE	over 240 HB 30	GH 100 U RS 100 F GH 100 H	900	625	400	275	275	.0005	.0013	.0016	.0020	.0023	.0027	.0036	.0042
Aluminum, Al-wrought alloys, Al-alloys 2024, 6061, 7075, 1050, 6351, 5005, 2017, 7075	BLACK	up to 3% Si	GA 200 A GS 100 A GH 100 U	1500	1500	1500	1000	1000	.0009	.0021	.0026	.0032	.0041	.0052	.0061	.0081
Aluminum-cast alloys High Silicon - A380, A390, Castings, 3.2131 G-AISI-5Cu1, 3.2153 G-AISI7Cu3, 3.2573 G-AISI9, 3.2581 G-AISI12, 3.2583 G-AISI12Cu, - G-AISI12CuNiMg	BLACK	over 3% Si	GA 200 A GS 100 A GH 100 U	1500	1500	1200	700	700	.0007	.0017	.0021	.0025	.0032	.0042	.0049	.0065
Magnesium Alloys	PURPLE	-	GA 200 A GS 100 A GH 100 U	2100	1500	800	650	650	.0006	.0013	.0017	.0020	.0026	.0033	.0039	.0052
Non-ferrous Copper Alloys, Brass, Bronze	BROWN	up to 28 HRc	GH 100 U GH 100 U GS 100 A	1500	1000	575	450	450	.0005	.0009	.0013	.0016	.0019	.0025	.0030	.0041

FEEDS & SPEEDS FOR ALL Uni-Pro

Normal

$$RPM = \frac{SFM}{d_1} \times 3.82 \quad IPM = \text{No. of teeth} \times IPT \times RPM$$

Example - Adjusting SFM and IPT for

1/2" diameter end mill, WOC .050", material 1018

SFM
WOC / d1 = xx%
.050 / .500 = 10%
WOC = 10%
SFM = 1350

IPT
WOC 10%
10% = 1.8 IPT multiplier
IPT .0026 x 1.8 = .0047
IPT = .0047

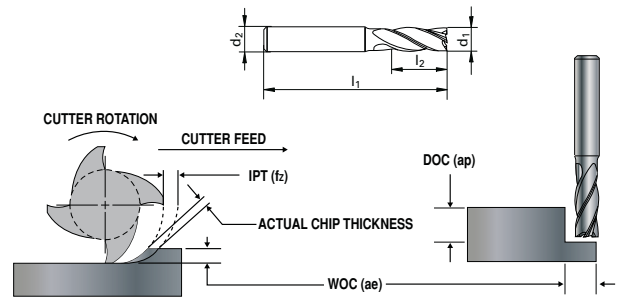

If surface finish is the priority use IPT from table with no adjustment for chip thinning. Use SFM for 10% radial width of cut.

Material	Color Code	Hardness	Uni-Pro	Surface Feet per Minute - SFM					Feed Rate Inch per Tooth - IPT							
				Radial Width of Cut WOC (ae)					d1 End Mill Diameter							
				5%	10%	30%	50%	100% Slotting	1/8	1/4	5/16	3/8	1/2	5/8	3/4	1
				2.3	1.8	1.1	1	1	Multiply IPT x this factor based on WOC							
Free Machining & Low Carbon Steels 1006, 1008, 1015, 1018, 1020, 1022, 1025, 1117, 1140, 1141, 11L08, 11L14, 1213, 12L13, 12L14, 1215, 1330	GREEN	up to 28 HRc		1275	1013	563	319	319	.0005	.0011	.0014	.0017	.0020	.0023	.0030	.0035
Medium Carbon & High Carbon Steels, Alloy Steels & Easy to Machine Tool Steels 1030, 1035, 1040, 1045, 1050, 1052, 1055, 1060, 1085, 1095, 1541, 1551, 9255, 2515, 3135, 3415, 4130, 4137, 4140, 4150, 4320, 4340, 4520, 5015, 5115, 5120, 5132, 5140, 5155, 6150, 8620, 9262, 9840, 52100, O1, O2, O6, S2, W1 to W310	GREEN RED	28 to 38 HRc		675	469	263	206	206	.0005	.0011	.0014	.0017	.0020	.0023	.0030	.0035
Tool Steels & Die Steels O7, M1, M2, M3, M4, M7, T1, T2, T4, T5, T8, T15, A2, A3, A6, A7, H10, H11, H12, H13, H19, H21, L3, L6, L7, P2, P20, S1, S5, S7, 52100, A 128, D2, D3, D4, D5, D7	RED	28 to 44 HRc		413	338	225	150	150	.0004	.0009	.0011	.0014	.0017	.0020	.0026	.0029
Hardened Steels Carbon and Alloy Steels, Tool & Die Steels	H H	up to 54 HRc		244	0	0	0	0	.0002	.0005	.0008	.0009	.0011	.0015	.0018	.0023
		54 to 60 HRc		150	0	0	0	0	.0002	.0003	.0005	.0008	.0009	.0013	.0015	.0019
Stainless Steel - Easy to Machine 430F, 301, 303, 410, 416 Annealed, 420F, 430, 430F	BLUE	up to 28 HRc		788	544	300	244	244	.0005	.0011	.0014	.0017	.0020	.0023	.0030	.0035
Stainless Steel - Moderately Difficult 301, 302, 303 High Tensile, 304, 304L, 305, 420, 15-5PH, 17-4PH, 17-7PH* 28 HRc	BLUE	up to 28 HRc		488	338	188	150	150	.0004	.0009	.0011	.0014	.0017	.0020	.0023	.0028
Stainless Steel - Difficult to Machine 302B, 304B, 309, 310, 316, 316B, 316L, 316Ti, 317, 317L, 321, PH13-8MO, Nitronic* 28 HRc	BLUE	over 28 HRc		450	300	169	131	131	.0004	.0008	.0009	.0012	.0014	.0018	.0021	.0028
High-Temperature Alloys Nimonic, Inconel, Monel, Hastelloy	GRAY	up to 42 HRc		90	90	90	75	75	.0002	.0005	.0008	.0009	.0011	.0015	.0018	.0023
Titanium Alloys 6Al-4V, 5Al-2.5 Sn, 6Al-2Sn-4Zr-6Mo, 3Al-8V-6Cr4Mo-4Zr, 10V-2Fe-3Al, 13V-11Cr-3Al	GRAY	up to 42 HRc		263	225	188	113	113	.0004	.0009	.0011	.0014	.0017	.0021	.0026	.0030
Cast Iron - Gray CG ASTM A48, CLASS 20, 25, 30, 35, SAE J431C, GRADES G1800, G3000, G3500, GG 10, 15, 20, 25, 30, 35, 40	WHITE	up to 240 HB 30		975	825	563	281	281	.0005	.0011	.0014	.0017	.0020	.0023	.0030	.0035
Cast Iron - Ductile & Malleable CGI 60-40-18, 65-45-12, D4018, D4512, D5506, 32510, 35108, M3210, M4504, M5503, 250, 300, 350, 400, 450	WHITE	over 240 HB 30		675	469	300	206	206	.0005	.0011	.0014	.0017	.0020	.0023	.0030	.0035
Aluminum, Al-wrought alloys, Al-alloys 2024, 6061, 7075, 1050, 6351, 5005, 2017, 7075	BLACK	up to 3% Si		1125	1125	1125	750	750	.0008	.0017	.0022	.0026	.0034	.0044	.0051	.0068
Aluminum-cast alloys High Silicon - A380, A390, Castings, 3.2131 G-ALSI-5Cu1, 3.2153 G-ALSI7Cu3, 3.2573 G-ALSI9, 3.2581 G-ALSI12, 3.2583 G-ALSI12Cu, - G-ALSI12CuNiMg	BLACK	over 3% Si		1125	1125	900	525	525	.0006	.0014	.0017	.0021	.0027	.0035	.0041	.0054
Magnesium Alloys	PURPLE	-		1575	1125	600	488	488	.0005	.0011	.0014	.0017	.0022	.0028	.0033	.0043
Non-ferrous Copper Alloys, Brass, Bronze	BROWN	up to 28 HRc		1125	750	431	338	338	.0004	.0008	.0011	.0013	.0016	.0021	.0025	.0035

a_e = Width of cut

a_p = Depth of cut

$$\text{RPM} = V_c \times 1000 / (3.14 \times d_1)$$

$$\text{mm/min} = f_z \times z \times \text{RPM}$$

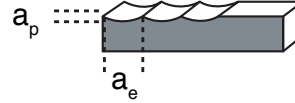
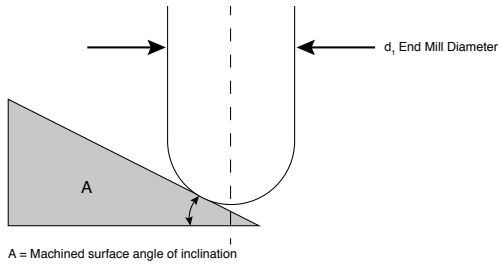

- 1 - Roughing = surface milling, machined surface angle A less than 15°.
- 2 - Finishing = contour milling, machined surface angle A between 15° and 90°.
- 3 - Reduce feeds and speeds 20% for tool projection greater than 5xD.
- 4 - Use d1 to calculate RPM (do not use effective diameter).
- 5 - ALL VALUES IN METRIC.

		d1 End Mill Diameter							
		2	3	4	6	8	10	12	16
Roughing A < 15°	ap	0.14	0.21	0.28	0.60	0.80	1.00	1.20	1.60
	ae	0.60	0.90	1.20	1.80	2.40	3.00	3.60	4.80
Finishing A > 15°	ap	0.10	0.15	0.20	0.30	0.40	0.50	0.60	0.80
	ae	0.04	0.06	0.08	0.12	0.16	0.20	0.24	0.32

Material	Color Code	Hardness	HSC	Type of Cut	Cutting Speed m/min (Vc)	Feed / tooth fz (mm/z)							
						2	3	4	6	8	10	12	16
Free Machining & Low Carbon Steels 1006, 1008, 1015, 1018, 1020, 1022, 1025, 1117, 1140, 1141, 11L08, 11L14, 1213, 12L13, 12L14, 1215, 1330	GREEN	up to 28 HRc	GF 500	Roughing	300	0.03	0.05	0.07	0.11	0.15	0.18	0.19	0.24
			GF 500	Finishing	275	0.06	0.07	0.09	0.11	0.12	0.13	0.14	0.14
Medium Carbon & High Carbon Steels, Alloy Steels & Easy to Machine Tool Steels 1030, 1035, 1040, 1045, 1050, 1052, 1055, 1060, 1085, 1095, 1541, 1551, 9255, 2515, 3135, 3415, 4130, 4137, 4140, 4150, 4320, 4340, 4520, 5015, 5115, 5120, 5132, 5140, 5155, 6150, 8620, 9262, 9840, 52100, O1, O2, O6, S2, W1 to W310	GREEN RED	28 to 38 HRc	GF 500	Roughing	300	0.03	0.05	0.06	0.09	0.13	0.16	0.17	0.21
			GF 500	Finishing	275	0.06	0.07	0.09	0.11	0.12	0.13	0.14	0.14
Tool Steels & Die Steels O7, M1, M2, M3, M4, M7, T1, T2, T4, T5, T8, T15, A2, A3, A6, A7, H10, H11, H12, H13, H19, H21, L3, L6, L7, P2, P20, S1, S5, S7, 52100, A128, D2, D3, D4, D5, D7	RED	28 to 44 HRc	GF 500	Roughing	275	0.03	0.05	0.06	0.09	0.13	0.16	0.17	0.21
			GF 500	Finishing	250	0.06	0.07	0.09	0.11	0.12	0.13	0.14	0.14
Hardened Steels Carbon and Alloy Steels, Tool & Die Steels	H	up to 54 HRc	GF 500	Roughing	225	0.03	0.04	0.06	0.09	0.12	0.14	0.15	0.18
			GF 500	Finishing	215	0.05	0.06	0.08	0.11	0.12	0.13	0.13	0.14
	H	54 to 60 HRc	GF 500	Roughing	170	0.02	0.04	0.05	0.08	0.10	0.13	0.14	0.16
			GF 500	Finishing	185	0.05	0.06	0.08	0.10	0.11	0.12	0.13	0.13
Stainless Steel - Easy to Machine 430F, 301, 303, 410, 416 Annealed, 420F, 430, 430F	BLUE	up to 28 HRc	GF 500	Roughing	275	0.03	0.05	0.07	0.11	0.15	0.18	0.19	0.24
			GF 500	Finishing	225	0.06	0.07	0.09	0.11	0.12	0.13	0.14	0.14
Stainless Steel - Moderately Difficult 301, 302, 303 High Tensile, 304, 304L, 305, 420, 15-5PH, 17-4PH, 17-7PH* 28 HRc	BLUE	up to 28 HRc	GF 500	Roughing	225	0.03	0.05	0.07	0.11	0.15	0.18	0.19	0.24
			GF 500	Finishing	200	0.06	0.07	0.09	0.11	0.12	0.13	0.14	0.14
Stainless Steel - Difficult to Machine 302B, 304B, 309, 310, 316, 316B, 316L, 316Ti, 317, 317L, 321, PH13-8MO, Nitronic	BLUE	over 28 HRc	GF 500	Roughing	225	0.03	0.05	0.06	0.09	0.13	0.16	0.17	0.21
			GF 500	Finishing	175	0.06	0.07	0.09	0.11	0.12	0.13	0.14	0.14
High-Temperature Alloys Nimonic, Inconel, Monel, Hastelloy	GRAY	up to 42 HRc	GF 500	Roughing	100	0.03	0.05	0.06	0.09	0.13	0.16	0.17	0.21
			GF 500	Finishing	50	0.06	0.07	0.09	0.11	0.12	0.13	0.14	0.14
Titanium Alloys 6Al-4V, 5Al-2.5 Sn, 6Al-2Sn-4Zr-6Mo, 3Al-8V-6Cr4Mo-4Zr, 10V-2Fe-3Al, 13V-11Cr-3Al	GRAY	up to 42 HRc	GF 500	Roughing	150	0.03	0.05	0.06	0.09	0.13	0.16	0.17	0.21
			GF 500	Finishing	75	0.06	0.07	0.09	0.11	0.12	0.13	0.14	0.14
Cast Iron - Gray CG ASTM A48, CLASS 20, 25, 30, 35, SAE J431C, GRADES G1800, G3000, G3500, GG 10, 15, 20, 25, 30, 35, 40	WHITE	up to 240 HB 30	GF 500	Roughing	275	0.03	0.05	0.07	0.11	0.15	0.18	0.19	0.24
			GF 500	Finishing	200	0.06	0.07	0.09	0.11	0.12	0.13	0.14	0.14
Cast Iron - Ductile & Malleable CGI 60-40-18, 65-45-12, D4018, D4512, D5506, 32510, 35108, M3210, M4504, M5503, 250, 300, 350, 400, 450	WHITE	over 240 HB 30	GF 500	Roughing	275	0.03	0.05	0.07	0.11	0.15	0.18	0.19	0.24
			GF 500	Finishing	200	0.06	0.07	0.09	0.11	0.12	0.13	0.14	0.14
Aluminum, Al-wrought alloys, Al-alloys 2024, 6061, 7075, 1050, 6351, 5005, 2017, 7075	BLACK	up to 3% Si											
Aluminum-cast alloys High Silicon - A380, A390, Castings, 3.2131 G-ALSi5Cu1, 3.2153 G-ALSi7Cu3, 3.2573 G-ALSi9, 3.2581 G-ALSi12, 3.2583 G-ALSi12Cu, - G-ALSi12CuNiMg	BLACK	over 3% Si											
Magnesium Alloys	PURPLE	-											
Non-ferrous Copper Alloys, Brass, Bronze	BROWN	up to 28 HRc											

FEEDS & SPEEDS FOR ALL HSC GF500 T & GF300 T Torus

- 1 - Roughing = surface milling, machined surface angle A equals 0°.
- 2 - Finishing = contour milling, machined surface angle A between 0° and 90°.
- 3 - Reduce feeds and speeds 20% for tool projection greater than 5xD.
- 4 - ALL VALUES IN METRIC.

$$RPM = Vc \times 1000 / (3.14 \times d1)$$

$$mm/min = fz \times z \times RPM$$

Roughing feed / tooth can be increased when ap / radius is less than 25% -
 Example - series 3856 10.000 diameter x 3.00 radius.

Roughing table ap = .75

End mill radius = 3.00

.75 / 3.00 = 25%

Multiply table roughing feed / tooth by 2.

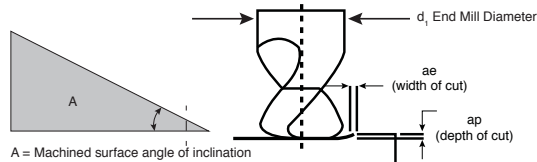

		d, End Mill Diameter							
		2	3	4	6	8	10	12	16
Roughing A < 15°	ap	0.14	0.21	0.28	0.42	0.60	0.75	1.00	1.36
	ae	1.16	1.74	2.32	3.48	5.52	6.50	8.52	11.52
Finishing A > 15°	ap	0.05	0.08	0.10	0.15	0.20	0.30	0.40	0.50
	ae	0.04	0.06	0.08	0.12	0.16	0.20	0.24	0.32

Material	Color Code	Hardness	HSC	Type of Cut	Cutting Speed m/min (Vc)	fz (mm/z) EXPRESSED AS % OF TOOL DIAMETER							
						2	3	4	6	8	10	12	16
Free Machining & Low Carbon Steels 1006, 1008, 1015, 1018, 1020, 1022, 1025, 1117, 1140, 1141, 11L08, 11L14, 1213, 12L13, 12L14, 1215, 1330	GREEN	up to 28 HRc	GF 500	Roughing	175	0.03	0.04	0.05	0.05	0.07	0.10	0.12	0.15
			GF 500	Finishing	300	0.03	0.04	0.05	0.05	0.07	0.10	0.12	0.15
Medium Carbon & High Carbon Steels, Alloy Steels & Easy to Machine Tool Steels 1030, 1035, 1040, 1045, 1050, 1052, 1055, 1060, 1085, 1095, 1541, 1551, 9255, 2515, 3135, 3415, 4130, 4137, 4140, 4150, 4320, 4340, 4520, 5015, 5115, 5120, 5132, 5140, 5155, 6150, 8620, 9262, 9840, 52100, O1, O2, O6, S2, W1 to W310	GREEN RED	28 to 38 HRc	GF 500	Roughing	150	0.03	0.04	0.05	0.05	0.07	0.10	0.12	0.15
			GF 500	Finishing	250	0.03	0.04	0.05	0.05	0.07	0.10	0.12	0.15
Tool Steels & Die Steels O7, M1, M2, M3, M4, M7, T1, T2, T4, T5, T8, T15, A2, A3, A6, A7, H10, H11, H12, H13, H19, H21, L3, L6, L7, P2, P20, S1, S5, S7, 52100, A 128, D2, D3, D4, D5, D7	RED	28 to 44 HRc	GF 500	Roughing	150	0.03	0.04	0.05	0.05	0.07	0.10	0.12	0.15
			GF 500	Finishing	225	0.03	0.04	0.05	0.05	0.07	0.10	0.12	0.15
Hardened Steels Carbon and Alloy Steels, Tool & Die Steels	H	up to 54 HRc	GF 500	Roughing	125	0.02	0.03	0.04	0.04	0.05	0.07	0.08	0.10
			GF 500	Finishing	150	0.03	0.04	0.05	0.05	0.07	0.10	0.12	0.15
	H	54 to 60 HRc	GF 300	Roughing	75	0.02	0.03	0.04	0.04	0.05	0.07	0.08	0.10
			GF 300	Finishing	110	0.03	0.03	0.04	0.05	0.05	0.07	0.10	0.12
Stainless Steel - Easy to Machine 430F, 301, 303, 410, 416 Annealed, 420F, 430, 430F	BLUE	up to 28 HRc	GF 500	Roughing	180	0.03	0.04	0.05	0.05	0.07	0.10	0.12	0.15
			GF 500	Finishing	300	0.03	0.04	0.05	0.05	0.07	0.10	0.12	0.15
Stainless Steel - Moderately Difficult 301, 302, 303 High Tensile, 304, 304L, 305, 420, 15-5PH, 17-4PH, 17-7PH* 28 HRc	BLUE	up to 28 HRc	GF 500	Roughing	110	0.02	0.03	0.04	0.04	0.05	0.07	0.08	0.10
			GF 500	Finishing	150	0.03	0.03	0.04	0.05	0.05	0.07	0.10	0.12
Stainless Steel - Difficult to Machine 302B, 304B, 309, 310, 316, 316B, 316L, 316Ti, 317, 317L, 321, PH13-8MO, Nitronic	BLUE	over 28 HRc	GF 500	Roughing	80	0.02	0.03	0.04	0.04	0.05	0.07	0.08	0.10
			GF 500	Finishing	130	0.03	0.03	0.04	0.05	0.05	0.07	0.10	0.12
High-Temperature Alloys Nimonic, Inconel, Monel, Hastelloy	GRAY	up to 42 HRc	GF 500	Roughing	40	0.01	0.02	0.03	0.04	0.04	0.05	0.07	0.08
			GF 500	Finishing	60	0.02	0.03	0.03	0.04	0.05	0.06	0.08	0.09
Titanium Alloys 6Al-4V, 5Al-2.5 Sn, 6Al-2Sn-4Zr-6Mo, 3Al-8V-6Cr4Mo-4Zr, 10V-2Fe-3Al, 13V-11Cr-3Al	GRAY	up to 42 HRc	GF 500	Roughing	90	0.02	0.03	0.04	0.04	0.05	0.07	0.08	0.10
			GF 500	Finishing	125	0.03	0.03	0.04	0.05	0.05	0.07	0.10	0.12
Cast Iron - Gray CG ASTM A48, CLASS 20, 25, 30, 35, SAE J431C, GRADES G1800, G3000, G3500, GG 10, 15, 20, 25, 30, 35, 40	WHITE	up to 240 HB 30	GF 500	Roughing	200	0.03	0.04	0.05	0.05	0.07	0.10	0.12	0.15
			GF 500	Finishing	350	0.03	0.04	0.05	0.05	0.07	0.10	0.12	0.15
Cast Iron - Ductile & Malleable CGI 60-40-18, 65-45-12, D4018, D4512, D5506, 32510, 35108, M3210, M4504, M5503, 250, 300, 350, 400, 450	WHITE	over 240 HB 30	GF 500	Roughing	175	0.03	0.04	0.05	0.05	0.07	0.10	0.12	0.15
			GF 500	Finishing	275	0.03	0.04	0.05	0.05	0.07	0.10	0.12	0.15
Aluminum, Al-wrought alloys, Al-alloys 2024, 6061, 7075, 1050, 6351, 5005, 2017, 7075	BLACK	up to 3% Si											
Aluminum-cast alloys High Silicon - A380, A390, Castings, 3.2131 G-AISI5Cu1, 3.2153 G-AISI7Cu3, 3.2573 G-AISI9, 3.2581 G-AISI12, 3.2583 G-AISI12Cu, - G-AISI12CuNiMg	BLACK	over 3% Si											
Magnesium Alloys	PURPLE	-											
Non-ferrous Copper Alloys, Brass, Bronze	BROWN	up to 28 HRc											

GUHRING Series No. Index

	Guhring Select	Description	Type	Surface Finish	Page
3011		UNI PRO extra long length end mills (2-fluted), metric	N	Bright	128
3012		UNI PRO XL end mills (4-fluted), metric	N	Bright	136
3014		UNI PRO extra long length ball nose end mills (2-fluted), metric	N	Bright	139
3015		UNI PRO XL ball nose end mills (4-fluted), metric	N	Bright	141
3019		FINISH-TECH / GH 100 U standard length multi-flute end mills, metric	NH	Bright	105
3021		UNI PRO extra long length end mills (2-fluted), metric	N	FIREX®	128
3023		UNI PRO XL end mills (4-fluted), metric	N	FIREX®	136
3024		UNI PRO standard length ball nose end mills (2-fluted), metric	N	Bright	139
3030		UNI PRO XL ball nose end mills (2-fluted), metric	N	FIREX®	139
3043		UNI PRO XL ball nose end mills (4-fluted), metric	N	FIREX®	141
3047		FINISH-TECH / GH 100 U standard length multi-flute end mills, metric	NH	FIREX®	104
3049		UNI PRO standard length ball nose end mills (2-fluted), metric	N	FIREX®	139
3053		RF 100 VA variable helix end mills (4-fluted)	VA	nano-Si®	42
3059		ALUMI-TECH standard length end mills (2-fluted), metric	W	Bright	90
3060		RF 100 VA/NF variable helix end mills (4-fluted)	VA/NF	nano-Si®	49
3077		RF 100 A standard length variable helix end mills for aluminum	W	Bright	53
3078		RF 100 F standard length variable helix end mills for materials < 30 HRC	NH	FIREX®	39
3079	✓	RF 100 U standard length variable helix end mills, corner radius, for materials < 54 HRC	N	FIREX®	27
3080		RF 100 VA standard length variable helix end mills for stainless steels	N	nano-A™	41
3081		RF 100 VA/NF standard length variable helix roughing-finishing end mills for stainless steels	NF	nano-A™	47
3082		RF 100 U/HF standard length variable helix roughing-finishing end mills, for materials < 54 HRC	HF	FIREX®	34
3084		FINISH-TECH 50 / GH 100 U end mills (6-fluted)	NH	nano-Si®	106
3086		AERO-TECH / GH 100 U stub length end mills (3-fluted)	NH	FIREX®	85
3087		UNI PRO "R" standard length end mills (2-fluted), corner radius	N	FIREX®	126
3088		UNI PRO "R" long length end mills (2-fluted), corner radius	N	FIREX®	126
3089		UNI PRO "R" standard length end mills (4-fluted), corner radius	N	FIREX®	133
3090		UNI PRO "R" XL end mills (4-fluted), corner radius	N	FIREX®	133
3091		FINISH-TECH 50 / GH 100 U standard length multi-flute end mills, corner radius	NH	FIREX®	103
3092		UNI PRO stub length end mills (2-fluted)	N	FIREX®	126
3093		UNI PRO stub length end mills (4-fluted)	N	FIREX®	133
3095		RF 50 stub length variable flute end mills (4-fluted)	N	FIREX®	37
3096		RF 50 standard length variable flute end mills (4-fluted)	N	FIREX®	37
3097		AERO-ROUGH 48 / RS 100 U standard length end mills	NF	FIREX®	95
3098		AERO-ROUGH 56 / RS 100 F standard length end mills	NF	FIREX®	96
3099	✓	RF 100 U stub length variable helix end mills for materials < 54 HRC	N	FIREX®	27
3100	✓	RF 100 U standard length variable helix end mills for materials < 54 HRC	N	FIREX®	27
3101		TRACE-TECH / GF 300 B standard length ball nose	H-HSC	FIREX®	111
3106		UNI PRO "R" standard length end mills (2-fluted), corner radius	N	Bright	128
3111		UNI PRO "R" standard length end mills (4-fluted), corner radius	N	Bright	136
3112		GH 100 U standard length multi-flute end mills, corner radius, metric	NH	Bright	105
3113	✓	RF 100 U stub length variable helix end mills for materials < 54 HRC	N	FIREX®	27
3114	✓	RF 100 U standard length variable helix end mills for materials < 54 HRC	N	FIREX®	27
3115		RF 100 SF standard length 6-flute variable helix end mills for materials < 54 HRC	NH	FIREX®	63
3126		ALUMI-TECH standard length end mills (2-fluted), metric	W	Bright	90
3127		ROUGH-TECH ALU / GS 100 A standard length end mills, coarse tooth, metric	WR	Bright	93
3146		UNI PRO standard length end mills (2-fluted)	N	Bright	126
3147		UNI PRO long length end mills (2-fluted)	N	Bright	126
3148		UNI PRO standard length end mills (2-fluted)	N	FIREX®	126
3149		UNI PRO long length end mills (2-fluted)	N	FIREX®	126
3150		UNI PRO standard length end mills (4-fluted)	N	Bright	133
3151		UNI PRO XL end mills (4-fluted)	N	Bright	133
3152		UNI PRO long length end mills (4-fluted),	N	Bright	133
3153		UNI PRO standard length end mills (4-fluted)	N	FIREX®	133
3155		UNI PRO XL end mills (4-fluted)	N	FIREX®	133
3156		UNI PRO long length end mills (4-fluted)	N	FIREX®	133
3157		UNI PRO standard length ball nose end mills (2-fluted)	N	Bright	138
3158		UNI PRO long length ball nose end mills (2-fluted)	N	Bright	138
3159		UNI PRO standard length ball nose end mills (2-fluted)	N	FIREX®	138
3160		UNI PRO long length ball nose end mills (2-fluted)	N	FIREX®	138
3161		UNI PRO standard length ball nose end mills (4-fluted)	N	Bright	140
3162		UNI PRO XL ball nose end mills (4-fluted)	N	Bright	140

GUHRING Series No. Index

	Guhring Select	Description	Type	Surface Finish	Page
3164		UNI PRO long length ball nose end mills (4-fluted)	N	Bright	140
3165		UNI PRO standard length ball nose end mills (4-fluted)	N	FIREX®	140
3166		UNI PRO XL ball nose end mills (4-fluted)	N	FIREX®	140
3167		UNI PRO long length ball nose end mills (4-fluted)	N	FIREX®	140
3168		UNI PRO standard length end mills (3-fluted)	N	Bright	130
3169		UNI PRO XL end mills (3-fluted)	N	Bright	130
3170		UNI PRO standard length end mills (3-fluted)	N	FIREX®	130
3171		UNI PRO XL end mills (3-fluted)	N	FIREX®	130
3172		AERO-TECH / GH 100 A standard length end mills (3-fluted)	NH	Bright	85
3173		AERO-TECH / GH 100 U standard length end mills (3-fluted)	NH	FIREX®	85
3174		ALUMI-TECH standard length end mills (2-fluted)	W	Bright	89
3175		ALUMI-TECH long length end mills (2-fluted)	W	Bright	89
3177		ALUMI-TECH / GA 200 A long length end mills (3-fluted)	W	Bright	91
3178		FINISH-TECH / GH 100 U standard length multi-flute end mills	NH	Bright	103
3179		FINISH-TECH / GH 100 U standard length multi-flute end mills	NH	FIREX®	103
3180		FINISH-TECH / GH 100 U long length multi-flute end mills	NH	Bright	103
3181		FINISH-TECH / GH 100 U long length multi-flute end mills	NH	FIREX®	103
3182		FINISH-TECH / GH 100 H standard length multi-flute end mills	H	FIREX®	103
3183		FINISH-TECH / GH 100 H long length multi-flute end mills	H	FIREX®	107
3184		ROUGH-TECH ALU / GS 100 A standard length end mills, coarse tooth	WR	Bright	93
3186		ROUGH-TECH 48 / GS 100 U standard length end mills, fine tooth	NRF	Bright	99
3188		ROUGH-TECH 48 / GS 100 U standard length end mills, fine tooth	NRF	FIREX®	99
3189		ROUGH-TECH 54 / GS 100 H standard length end mills, fine tooth	HR	FIREX®	101
3190		ROUGH-TECH 54 / GS 100 H long length end mills, fine tooth	HR	FIREX®	101
3191		TRACE-TECH / GF 300 B long length ball nose	H-HSC	FIREX®	111
3192		TRACE-TECH / GF 300 T long length cutters, Torus	H-HSC	FIREX®	113
3202		RF 100 A standard length variable helix end mills for aluminum, metric	W	Bright	53
3203		AERO-TECH / GH 100 U standard length end mills (3-fluted), metric	NH	Bright	86
3204		ROUGH-TECH 48 / GS 100 U standard length end mills, fine tooth, metric	NRF	Bright	99
3303		UNI PRO standard length end mills (2-fluted)	N	Bright	128
3304		UNI PRO standard length end mills (4-fluted)	N	Bright	136
3306		UNI PRO standard length ball nose end mills (4-fluted), metric	N	Bright	141
3307		UNI PRO standard length end mills (3-fluted), metric	N	Bright	131
3308		UNI PRO standard length ball nose end mills (2-fluted), metric	N	Bright	139
3309		ALUMI-TECH standard length end mills (2-fluted), metric	W	Bright	90
3310		ALUMI-TECH standard length end mills (2-fluted), metric	W	Bright	90
3311		FINISH-TECH / GH 100 U standard length multi-flute end mills, metric	NH	Bright	105
3312		FINISH-TECH / GH 100 U XL multi-flute end mills, metric	NH	Bright	105
3313		FINISH-TECH / GH 100 U XL multi-flute end mills, metric	NH	Bright	105
3314		UNI PRO XL end mills (3-fluted), metric	N	Bright	131
3319		RF 100 A standard length variable helix end mills for aluminum, metric	W	Bright	53
3358		ALUMI-TECH long length end mills (2-fluted), metric	W	Bright	90
3359		TRACE-TECH / GF 300 B standard length ball nose, metric	H-HSC	FIREX®	112
3360		TRACE-TECH / GF 300 B XL ball nose, metric	H-HSC	FIREX®	112
3362		TRACE-TECH / GF 300 T XL hard profile cutters, Torus, metric	H-HSC	FIREX®	113
3364		ROUGH-TECH ALU / GS 100 A standard length, coolant fed end mills, coarse tooth, metric	WR	Bright	93
3365		ROUGH-TECH 48 / GS 100 U standard length, coolant fed end mills, fine tooth, metric	NRF	FIREX®	99
3366		RF 100 F standard length variable helix end mills, coolant through, for materials < 30 HRC, metric	NH	FIREX®	39
3367		ALUMI-TECH / GA 200 A standard length, coolant fed end mills (3-fluted), metric	W	Bright	91
3468		RF 100 A/WF standard length variable helix rougher for aluminum, metric	WF	Bright	51
3469		RF 100 A/WF standard length variable helix rougher for aluminum, metric	WF	Bright	51
3470		RF 100 A/WF long length variable helix rougher for aluminum, metric	WF	Bright	51
3471		RF 100 A/WF long length variable helix rougher for aluminum, metric	WF	Bright	51
3472		RF 100 A 3-Flute variable helix end mills	W	Bright	55
3473		RF 100 A 3-Flute variable helix end mills, metric	W	Bright	55
3498		RF 100 Ti standard length variable helix end mills, corner radius, for titanium alloys, metric	N	Super-A™	58
3499		RF 100 Ti standard length variable helix end mills, corner radius, for titanium alloys, metric	N	Super-A™	58
3507		RF 100 U/HF standard lgth variable helix roughing-finishing end mills, for materials < 54 HRC, metric	HF	FIREX®	35
3508		RF 100 U/HF standard lgth variable helix roughing-finishing end mills, for materials < 54 HRC, metric	HF	FIREX®	35
3509		RF 100 U/HF long length variable helix roughing-finishing end mills, for materials < 54 HRC, metric	HF	FIREX®	35

GUHRING Series No. Index

	Guhring Select	Description	Type	Surface Finish	Page
3522		RF 100 U/HF long length variable helix roughing-finishing end mills, for materials < 54 HRC, metric	HF	FIREX®	35
3540		AERO-TECH / GH 100 U stub length end mills (3-fluted), metric	NH	FIREX®	86
3558		UNI PRO stub length end mills (3-fluted), metric	N	FIREX®	131
3561		UNI PRO "R" standard length end mills (2-fluted), corner radius, metric	N	FIREX®	128
3562		UNI PRO "R" standard length end mills (4-fluted), corner radius, metric	N	FIREX®	136
3563		GH 100 U standard length multi-flute end mills, corner radius, metric	NH	FIREX®	104
3598		RF 100 U/HF extra long variable helix roughing-finishing end mills, for materials < 54 HRC, metric	HF	FIREX®	35
3600		RF 100 U/HF extra long variable helix roughing-finishing end mills, for materials < 54 HRC, metric	HF	FIREX®	35
3627	✓	RF 100 U long length variable helix end mills for materials < 54 HRC, metric	N	FIREX®	29
3629		RF 100 F standard length variable helix end mills for materials < 30 HRC, metric	NH	FIREX®	39
3630		RF 100 F standard length variable helix end mills for materials < 30 HRC, metric	NH	FIREX®	39
3631		RF 100 SF standard length 6-flute variable helix end mills for materials < 54 HRC, metric	NH	FIREX®	63
3632		RF 100 SF standard length 6-flute variable helix end mills for materials < 54 HRC, metric	NH	FIREX®	63
3633		UNI PRO stub length end mills (2-fluted), metric	N	FIREX®	128
3634		UNI PRO stub length end mills (2-fluted), metric	N	FIREX®	128
3637		UNI PRO stub length end mills (4-fluted), metric	N	FIREX®	136
3667		UNI PRO end mills (3-fluted), metric	N	FIREX®	131
3676		UNI PRO standard length end mills (2-fluted), metric	N	FIREX®	128
3677		UNI PRO standard length end mills (3-fluted), metric	N	FIREX®	131
3678		UNI PRO standard length end mills (4-fluted), metric	N	FIREX®	136
3679		UNI PRO standard length ball nose end mills (2-fluted), metric	N	FIREX®	139
3680		UNI PRO XL end mills (3-fluted), metric	N	FIREX®	131
3682		ROUGH-TECH 54 / GS 100 H standard length end mills, fine tooth, metric	HR	FIREX®	101
3689		FINISH-TECH / GH 100 U standard length multi-flute end mills, metric	NH	FIREX®	104
3691		FINISH-TECH / GH 100 U XL multi-flute end mills, metric	NH	FIREX®	104
3693		FINISH-TECH / GH 100 U XL multi-flute end mills, metric	NH	FIREX®	104
3696		RF 100 VA/NF standard lgth variable helix roughing/finishing end mills for stainless steels, metric	NF	nano-A™	48
3715		FINISH-TECH / GH 100 H standard length multi-flute end mills, metric	H	FIREX®	108
3716		FINISH-TECH / GH 100 H long length multi-flute end mills, metric	H	FIREX®	108
3718		RF 100 VA/NF standard lgth variable helix roughing/finishing end mills for stainless steels, metric	NF	nano-A™	48
3719		UNI PRO stub length end mills (3-fluted), metric	N	FIREX®	131
3721		UNI PRO stub length end mills (4-fluted), metric	N	FIREX®	136
3723		ROUGH-TECH 48 / GS 100 U standard length end mills, fine tooth, metric	NRF	FIREX®	99
3727		UNI PRO standard length ball nose end mills (4-fluted), metric	N	FIREX®	141
3729		AERO-TECH / GH 100 U stub length end mills (3-fluted), metric	NH	FIREX®	86
3731	✓	RF 100 U stub length variable helix end mills for materials < 54 HRC, metric	N	FIREX®	29
3732	✓	RF 100 U standard length variable helix end mills for materials < 54 HRC, metric	N	FIREX®	29
3733		RF 100 VA/NF long length variable helix roughing/finishing end mills for stainless steels, metric	NF	nano-A™	48
3736	✓	RF 100 U standard length variable helix end mills for materials < 54 HRC, metric	N	FIREX®	29
3741		AERO-TECH / GH 100 U standard length end mills (3-fluted), metric	NH	FIREX®	86
3800		RF 100 VA standard length variable helix end mills for stainless steels, metric	N	nano-A™	43
3803		RF 100 VA standard length variable helix end mills for stainless steels, metric	N	nano-A™	43
3804		RF 100 VA stub length variable helix end mills for stainless steels, metric	N	nano-A™	43
3805		RF 100 VA stub length variable helix end mills for stainless steels, metric	N	nano-A™	43
3806		RF 100 VA long length variable helix end mills for stainless steels, metric	N	nano-A™	43
3807		RF 100 VA long length variable helix end mills for stainless steels, metric	N	nano-A™	43
3837	✓	RF 100 U long length variable helix end mills w/reduced neck for materials < 54 HRC, metric	N	FIREX®	29
3838	✓	RF 100 U long length variable helix end mills w/reduced neck for materials < 54 HRC, metric	N	FIREX®	29
3839	✓	RF 100 U long length variable helix end mills for materials < 54 HRC, metric	N	FIREX®	29
3846		UNI PRO standard length end mills (2-fluted)	N	Super-A™	126
3847		UNI PRO long length end mills (2-fluted)	N	Super-A™	126
3848		GF 500 B HSC standard length ball nose profile cutters, metric	N-HSC	TiAlN	116
3849		GF 500 B HSC XL ball nose profile cutters, metric	N-HSC	TiAlN	116
3850		UNI PRO standard length end mills (4-fluted)	N	Super-A™	133
3851		UNI PRO XL end mills (4-fluted)	N	Super-A™	133
3852		UNI PRO end mills (4-fluted), long length	N	Super-A™	133
3853		GF 500 B HSC XL ball nose profile cutters, metric	N-HSC	TiAlN	116
3854		GF 500 B HSC standard length ball nose profile cutters, metric	N-HSC	TiAlN	116
3855		GF 500 B HSC long length ball nose profile cutters, metric	N-HSC	TiAlN	116
3856		GF 500 T HSC standard length profile cutters with Torus form, metric	N-HSC	TiAlN	117

GUHRING Series No. Index

	Guhring Select	Description	Type	Surface Finish	Page
		UNI PRO standard length ball nose end mills (2-fluted)	N	Super-A™	138
		UNI PRO long length ball nose end mills (2-fluted)	N	Super-A™	138
		GF 500 T HSC XL profile cutters with Torus form, metric	N-HSC	TiAlN	117
		GF 500 T HSC XL profile cutters with Torus form, Metric	N-HSC	TiAlN	117
		Uni-Pro 4-flute, ball nose	N	Bright	140
		Uni-Pro 4-flute, ball nose	N	Super-A™	140
		GF500 T 2-flute, Torus form	N	TiAlN	117
		Uni-Pro 4-flute, ball nose	N	Super-A™	140
		GF500 T 2-flute, Torus form, Metric	N	TiAlN	117
		GF500 B 2-flute, Ball nose, Metric	N	TiAlN	116
		DL 100 X2 Center cutting end mills (2-flute)	N	PCD Tipped	69
		Uni-Pro 3-flute	N	Super-A™	130
		Uni-Pro 3-flute	N	Super-A™	130
		DL 100 X2 Center cutting end mills (3-flute)	N	PCD Tipped	69
	✓	RF 100 U 4-Flute, Variable helix, Metric	N	FIREX®	29
	✓	RF 100 U 4-Flute, Variable helix, Metric	N	FIREX®	29
	✓	RF 100 U 4-Flute, Variable helix, Metric	N	FIREX®	29
		GA 200 A 2-flute, ALUMI-TECH	W	Super-A™	89
		GA 200 A 2-flute, ALUMI-TECH	W	Super-A™	89
		RF 100 Ti 4-flute, Variable helix	N	Super-A™	57
		GA 200 A 3-flute, ALUMI-TECH	W	Super-A™	91
		GS 100 A 3-flute, ROUGH-TECH ALU, rougher	WR	Bright	93
		RF 100 VA/NF, Variable helix rougher, 4-flute	NF	nano-A™	48
		GS100 U 4/5-flute, ROUGH-TECH 48, rougher	NF	Super-A™	99
		RS 100 U 4/5-flute, AERO-ROUGH 48, rougher, Metric	NF	FIREX®	95
		RS 100 U 4/5-flute, AERO-ROUGH 48, rougher, Metric	NF	FIREX®	95
		RS 100 F 5/6-flute, AERO-ROUGH 56, rougher, Metric	NF	FIREX®	96
		RS 100 F 5/6-flute, AERO-ROUGH 56, rougher, Metric	NF	FIREX®	96
	✓	RF 100 U 3-Flute, Variable helix, Metric	N	FIREX®	33
	✓	RF 100 U 3-Flute, Variable helix, Metric	N	FIREX®	33
	✓	RF 100 U 3-Flute, Variable helix, Metric	N	FIREX®	33
	✓	RF 100 U 3-Flute, Variable helix, Metric	N	FIREX®	33
		RF 100 H 4-Flute, Variable helix, Metric	H	TiAlN	65
		RF 100 H 4-Flute, Variable helix, Metric	H	TiAlN	65
		RF 100 S/F 5-Flute, Variable helix, Metric	NH	FIREX®	62
		RF 100 S/F 5-Flute, Variable helix, Metric	NH	FIREX®	62
		RF 100 U 4-Flute, Variable helix	N	FIREX®	27
		RF 100 U 4-Flute, Variable helix	N	FIREX®	27
		RF 100 U 4-Flute, Variable helix	N	FIREX®	27
		RF 100 U 4-Flute, Variable helix	N	FIREX®	27
		RF 100 U 3-Flute, Variable helix	N	FIREX®	32
		RF 100 U 3-Flute, Variable helix	N	FIREX®	32
		RF 100 U/HF 4-Flute, Variable helix rougher	HF	FIREX®	34
		RF 100 VA 4-Flute, Variable helix square,	N	nano-A™	41
		RF 100 VA 4-Flute, Variable helix square,	N	nano-A™	41
		RF 100 VA 4-Flute, Variable helix square,	N	nano-A™	41
		RF 100 VA 4-Flute, Variable helix square,	N	nano-A™	41
		RF 100 VA 4-Flute, Variable helix ball nose	N	nano-A™	45
		RF 100 VA/NF 4-flute, Variable helix rougher	NF	nano-A™	47
		RF 100 S/F 5-flute, Variable helix	NF	FIREX®	61
		RF 100 S/F 5-flute, Variable helix	NF	FIREX®	61
		RF 100 A 4-Flute, Variable helix	W	Bright	54
		RF 100 A/WF 4-Flute, Variable helix	WF	Bright	51
		DL 100 X2 Center cutting end mills (2-flute)	N	PCD Tipped	70
		DL 100 X2 Center cutting end mills (2-flute)	N	PCD Tipped	70
		RF 100 VA 4-Flute, Variable helix square, Metric	N	nano-A™	43
		RF 100 VA 4-Flute, Variable helix square, Metric	N	nano-A™	43
		RF 100 A 3-Flute, Variable helix	W	Bright	55
		RF 100 A 3-Flute, Variable helix	W	Bright	55
		RF 100 U 4-Flute, Variable helix	N	FIREX®	29

	Guhring Select	Description	Type	Surface Finish	Page
6707		RF 100 VA 4-Flute, Variable helix ball nose, Metric	N	nano-A™	45
6708		RF 100 VA 4-Flute, Variable helix ball nose, Metric	N	nano-A™	45
6709		RF 100 S/F 5-Flute, Variable helix	NH	FIREX®	62
6710		RF 100 S/F 5-Flute, Variable helix	NH	FIREX®	62
6717		CR 100 multi-flute slotting carbide router	—	Diamond	73
6718		CR 100 multi-flute slotting carbide router, coolant fed	—	Diamond	73
6719		CR 100 multi-flute plunging carbide router	—	Diamond	73
6720		CR 100 multi-flute plunging carbide router	—	Diamond	73

DRILLING

TAPPING/
THREADMILLING/
FLUTELESS TAPPING

MILLING

REAMING

PCD/PCBN



SPECIAL TOOLING
SOLUTIONS

COUNTERSINKING/
DE-BURRING

MODULAR TOOLING
SYSTEMS

TOOL RECONDITIONING SERVICE

GUHRING

The Tool Company

Guhring, Inc. Main Office

P.O. Box 643, Brookfield, WI 53008-0643

Shipping Address

1445 Commerce Avenue

Brookfield, WI 53045

Tel (262) 784-6730 (800) 776-6170

Fax (262) 784-9096

**West Coast Distribution Center and
Reconditioning Facility**

15581 Computer Ln
Huntington Beach, CA 92649

Reconditioning Facility

121 W Dudley Town Rd.
Bloomfield, CT 06002

Manufacturing and

Reconditioning Facility

29550 W.K. Smith Rd. Suite B
New Hudson, MI 48165

Guhring Corporation

20 Steckle Place, Unit #14

Kitchener, ON N2E 2C3

Tel (519) 748-9664 (800) 463-5555

Fax (519) 748-2954