

Measuring and control technology for
the production of

High voltage cables

SIKORA
Technology To Perfection



Content

Introduction	3	5 X-RAY 6000 PRO	13
1 ULTRATEMP 6000	4	Measurement of the wall thickness, concentricity, diameter and ovality of single and multi-layer products	
Ultrasonic measurement system for polyethylene melts		6 SPARK 2000 BS	15
2 X-RAY 8000 ADVANCED/NXT	5	Alternating current (AC) spark tester	
X-ray measuring systems for MV, HV and EHV cables in CCV, VCV and MDCV lines		7 ECOCONTROL 6000/1000/600	16
3 LASER Series 2000	9	Premium processor systems with 22", 15" or 8.4" TFT color monitor and touch screen operation	
LASER Series 2000 XY models for efficient 2-axis diameter measurement		8 REMOTE 6000/DISPLAY 2000	18
LASER Series 2000 T models for efficient 3-axis diameter measurement		Standard display and control device/ Basic display device	
LASER Series 2000 S/R models for the efficient measurement of sector and round cables			
4 LASER Series 6000	11		
High-end diameter measuring in the area of Non Destructive Testing (NDT)			

Systems for length measurement are available upon request.

For information on SIKORA's product portfolio regarding inspection, analysis and sorting devices in the area of plastics, please refer to our catalog "Systems for inspection, sorting and analysis of XLPE and PP material".

Introduction

SIKORA AG is a leading manufacturer and supplier of innovative online measuring, control, inspection, analysis and sorting technology for the wire and cable, hose and tube, sheet, optical fiber and plastics industries. Worldwide, users of these measuring devices benefit from an increasing manufacturing quality, profitability and efficiency. Modern laser and X-ray technologies measure product parameters such as diameter, ovality, wall thickness and concentricity precisely and reliably.

Continuous control of production data is the basis for a repeatable process and helps to avoid wall thickness oversizes and allows a more efficient material usage. Every micrometer of insulation material that can be saved by the use of measuring and control technology makes production more economic and saves increasingly scarce resources.

SIKORA is headquartered in Bremen, Germany. Since 1973, the high-quality devices have been developed and manufactured at this site. When it comes to service and sales, SIKORA is globally active with subsidiaries in Brazil, China, France, India, Italy, Japan, Korea, Malaysia, Mexico, Poland, Russia, Turkey, Ukraine, the United Arab Emirates and the USA. In cooperation with more than 30 local representatives worldwide, SIKORA serves all customer demands for optimum quality control and productivity. In addition, international service locations assure fast and reliable customer support on site, any time.

Since 1993, SIKORA has met the requirements of DIN EN ISO 9001. The certification confirms SIKORA's focus on continuous improvement. Customer satisfaction is the primary objective.

Innovation, technological know-how, quality and service are the four pillars of SIKORA's company philosophy. A strong research and development team continuously works on the development of new technologies enabling manufacturers of high voltage cables to increase process reliability, efficiency and the ecological balance of their production lines.

Measuring technology for the high voltage cable production

Manufacturing of high voltage cables requires compliance with high-quality standards and numerous specifications. Today, cable manufacturers aim at producing economically and therefore, choose measuring devices, which are used in their lines for quality control. Specifically for the energy market, SIKORA has developed efficient and innovative technologies that assure quality during the complete production process. The measuring and control devices are suitable for application in CCV, VCV, MDCV* and sheathing lines.

* CCV (Catenary Continuous Vulcanization), VCV (Vertical Continuous Vulcanization), MDCV (Mitsubishi Dainichi Continuous Vulcanization)

1 ULTRATEMP 6000 – Ultra-strong temperature measurement

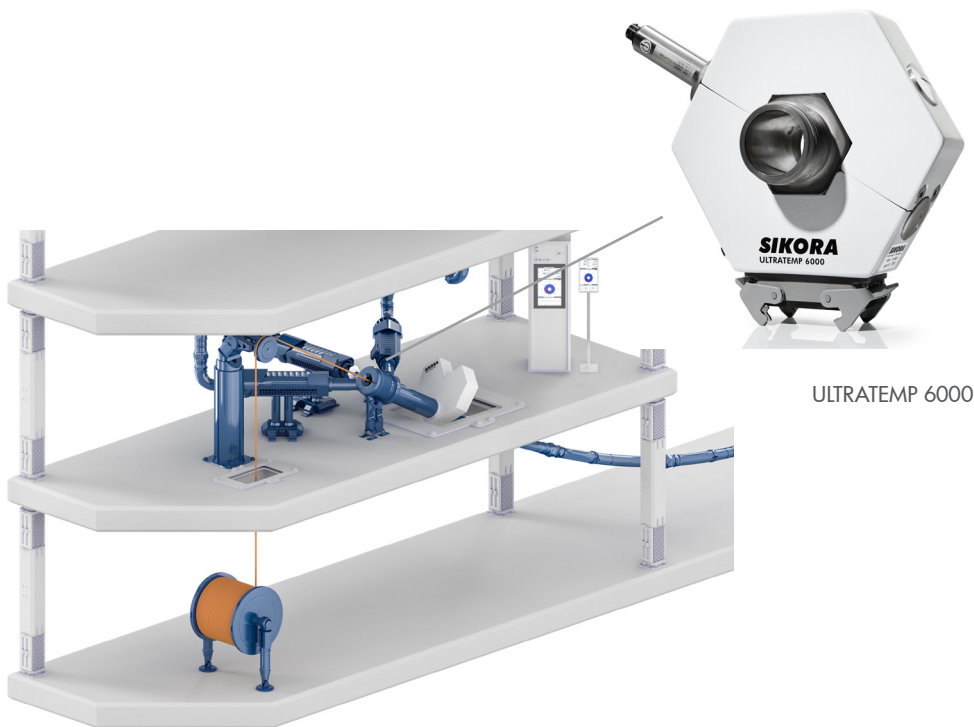

Ultrasonic temperature measurement system for polyethylene melts

The ULTRATEMP 6000 is an ultrasonic temperature measuring device for reliable measurement of polyethylene melts. The melt temperature of the polyethylene, which is used for insulation of cables, is extremely critical. A few degrees decide between a homogeneous and thus, optimum melt and the risk of unmelted or burned material.

The ULTRATEMP 6000 is a temperature measuring system, which continuously measures the temperature of the polyethylene melt precisely, directly in the mechanical flow channel between the extruder and crosshead. Therefore, it is an essential tool for longer production runs. It operates on a non-contact basis. Early cross-linking after screens, which may lead to ambers and scorches in the polyethylene material, are avoided by using the ULTRATEMP 6000.

The high measuring rate allows a fast response time and registers small temperature variations. The system does not influence the melt flow properties as the ultrasonic sensors are positioned outside of the flow channel. Therefore, melt shear heating effects do not occur.

The ULTRATEMP 6000 contributes to process optimization and costs reduction in CCV or VCV lines.

Typical features

- Maximization of the extruder output through optimum melt temperature
- Elimination of “scorches” and early cross-linking in the extruder head
- Non-contact, no melt shear heating effects

Technical Data ULTRATEMP 6000

Measuring Principle

Non-contact, non-invasive temperature measurement based on ultrasonic technology

Measuring Range

+ 100 to + 180 °C

Accuracy

< ± 1 °C deviation

Interfaces

Serial interface RS485, setup and diagnosis interface RS232
Optional: Profibus-DP, analog output

Power Supply

115 - 230 V AC ± 10 %, 50/60 Hz

2 X-RAY 8000 ADVANCED/NXT – Two perfect possibilities to control the quality of cables in CV lines



X-RAY 8000 ADVANCED

Typical features X-RAY 8000 NXT

- More than 1,500 X-RAY 8000 systems sold worldwide
- 8-point display of wall thickness and concentricity for three insulation layers
- XLL (eXtra Long Life) gate controlled X-ray tubes for highest reliability and long life
- Ceramic windows at the bottom, for a reliable long-term operation without cleaning, combined with NTX (NonToxic X-ray) windows (none Beryllium) at the top
- Unique Multi-Sensor-Technology
- Fast centering of the crosshead and optimum quality and process control
- No calibration, no warm-up

Additional features X-RAY 8000 ADVANCED

- Faster recording of measuring data by a factor of up to 10 directly after starting up the line enables an immediate control
- Optimization of the start-up process
- Ensurance of the highest cable quality at maximum material and cost savings

X-ray measuring systems for MV, HV and EHV cables in CCV, VCV and MDCV lines

The manufacturing of medium, high and extra-high voltage cables in CV lines is extremely demanding with regards to process control and process stability in order to fulfill the required high quality standards. Therefore, a continuous monitoring and control of the product parameters are necessary for a stable process.

X-RAY 8000 NXT – An invention of SIKORA that decisively shapes the high voltage cable production

The X-RAY 8000 NXT is a proven tool that became globally an industrial standard for quality control at the production of medium, high and extra-high voltage cables in CCV, VCV and MDCV lines. It convinces by precise and reliable measurements of concentricity, wall thickness, diameter and ovality as well as by controlling cables with up to three layers. Today there are more than 1,500 X-RAY 8000 systems at customer locations worldwide assuring online quality control.

The X-RAY 8000 NXT convinces with its Multi-Sensor-Technology (MST). The MST guarantees, in combination with two high speed scanners, accurate and reliable measurements of medium, high voltage and extra-high voltage cables, even when the cable is vibrating. Furthermore, due to the MST, every scan of the two scanners provides four measuring values, ensuring an extremely high accuracy.

X-RAY 8000 ADVANCED – While others still measure, we already control

With the X-RAY 8000 ADVANCED, SIKORA offers a system with state-of-the-art High Speed Technology (HST) that is tailored to the requirements of Industry 4.0. It represents an advanced alternative to the successful and established X-RAY 8000 NXT. The system – equipped with 16 measuring sensors – measures the diameter, wall thickness and eccentricity by a factor of up to 10 faster than the X-RAY 8000 NXT, and thus, is predestined for an efficient control.

Excellent are the advantages resulting from the centering as each change of the centering screws is immediately registered and visualized. The four times greater number of measuring points, compared to the NXT system, simultaneously leads to a measurement almost without delay and an immediate control. Both factors optimize the process and ensure the highest quality of the cables, at maximum material and cost savings.

The High Speed Technology (HST) is the latest innovation from SIKORA. The focus is on efficiency enhancement due to a fast centering and an automatic control of the product parameters. The basis for this are quick and reliable measuring values with the HST. For a fast update of the scan data, the system optimizes the scanning time by automatically adapting the scan path to the cable diameter.

Design

SIKORA's X-RAY 8000 devices consist of two components: the scanner unit and the control cabinet. Typically, the scanner unit is installed in the moving part of the telescopic tube, directly after the crosshead. Measuring values for centering and control are therefore, immediately available.

Integrated into the scanner unit are two high-speed scanners, which provide an X-ray picture of the cable from perpendicular directions.

The control cabinet includes an industrial PC for the analysis of the scan picture. The control of the scanner motors and the high voltage supply are safely located in the control cabinet. In this position, these components are not exposed to the high temperatures.

Analysis

All measuring values are calculated directly from the X-ray picture by regression analysis. This concept provides measuring values of the highest accuracy and repeatability, requires no calibration, no fine tuning, no warm-up period and no pre-setting for the absorption parameter of the different insulating materials.

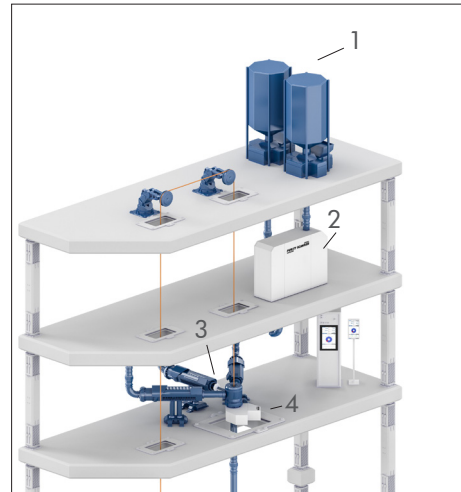
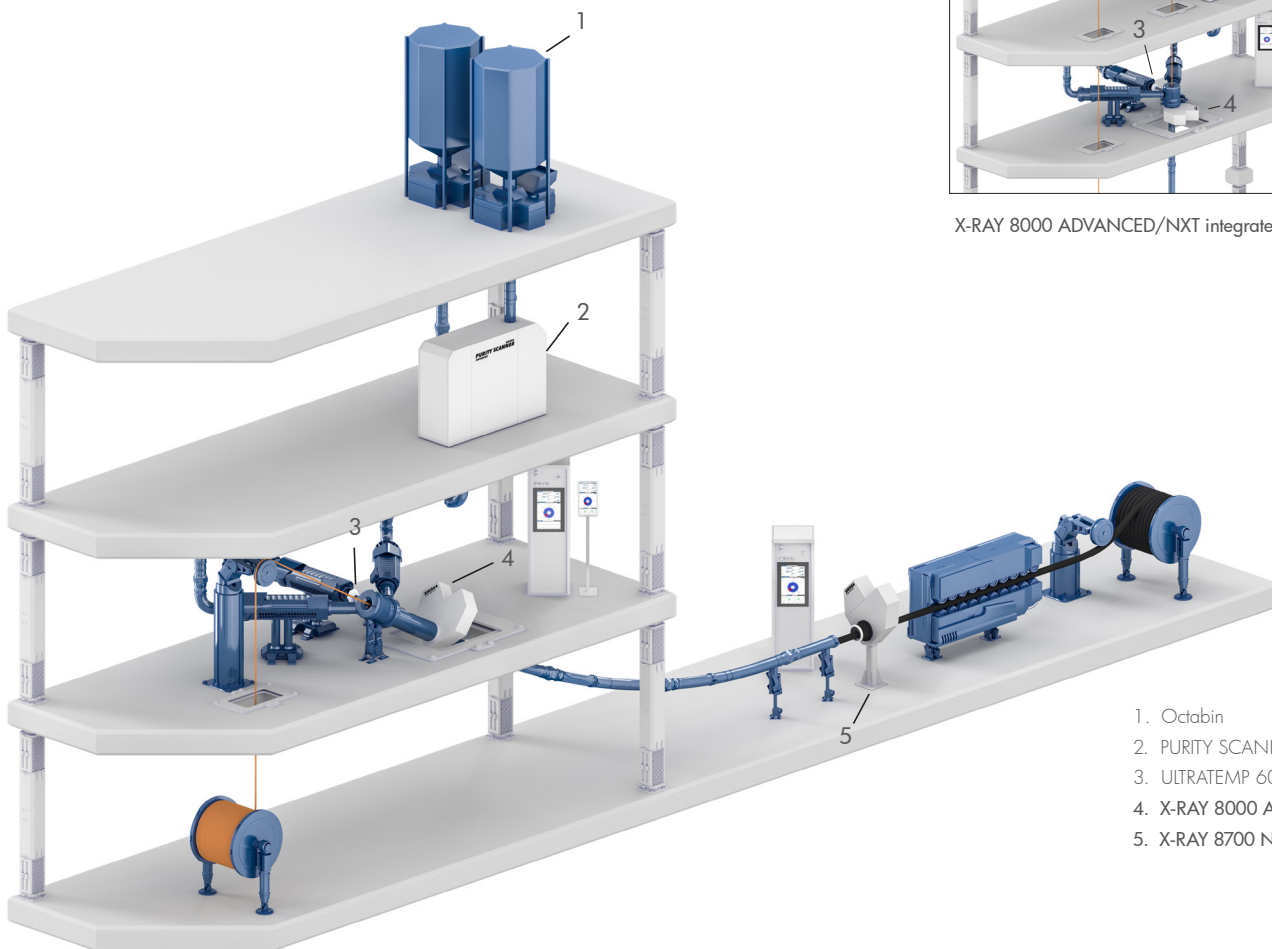

X-RAY 8000 ADVANCED/NXT integrated in a VCV line

- 1. Octabin
- 2. PURITY SCANNER ADVANCED
- 3. ULTRATEMP 6000 (p. 4)
- 4. X-RAY 8000 ADVANCED/NXT
- 5. X-RAY 8700 NXT

X-RAY 8000 ADVANCED/NXT integrated in a CCV line

Integration of the X-RAY 8000 ADVANCED/NXT in the production line

With the X-RAY 8000 ADVANCED/NXT, visions are transferred into advantages. The X-ray based measuring systems, installed in the moving part of the telescopic tube directly after the crosshead, provide efficiency on the highest level. They are applicable for steam and nitrogen lines and measure the wall thickness of all three insulation layers, the concentricity, diameter and ovality of XLPE and EPR insulated cables. Immediately after starting up the line, the measuring values are available for centering and control.

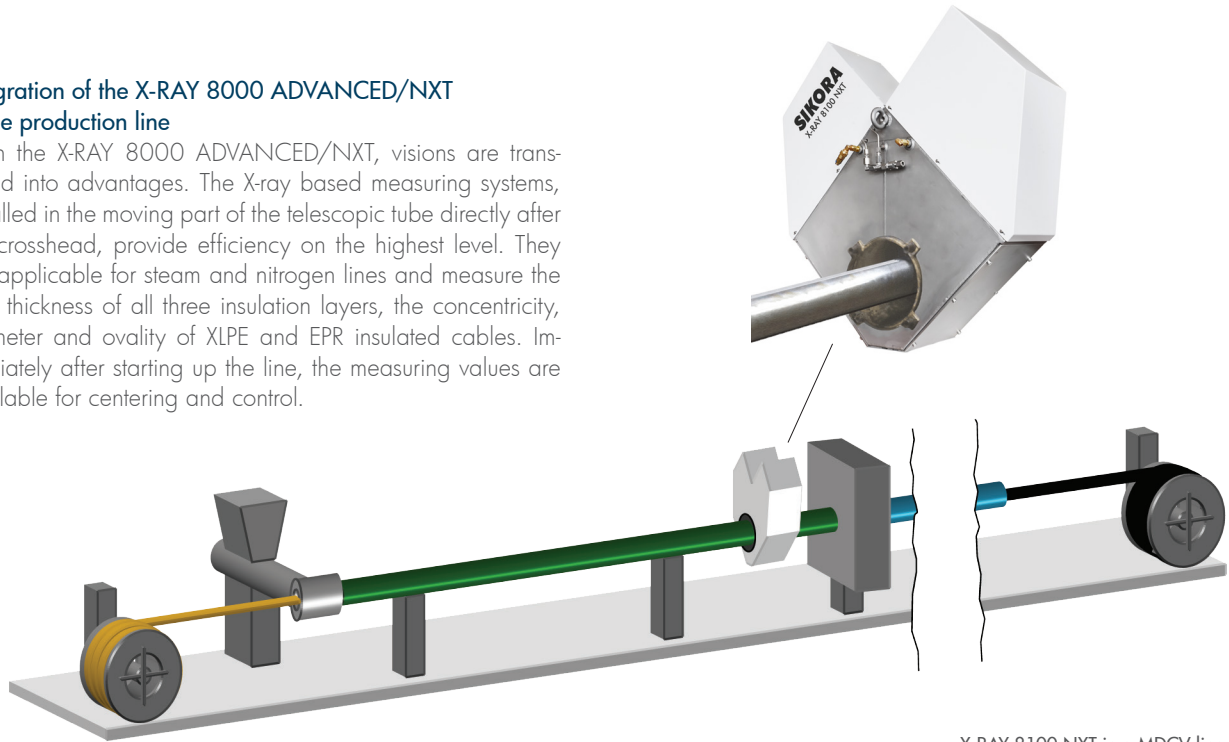

X-RAY 8100 NXT in a MDCV line

X-RAY 8000 ADVANCED/NXT in MDCV lines

For the measurement of the wall thickness, concentricity, diameter and ovality of high voltage cables in an MDCV line, SIKORA recommends the X-RAY 8100 ADVANCED/NXT.

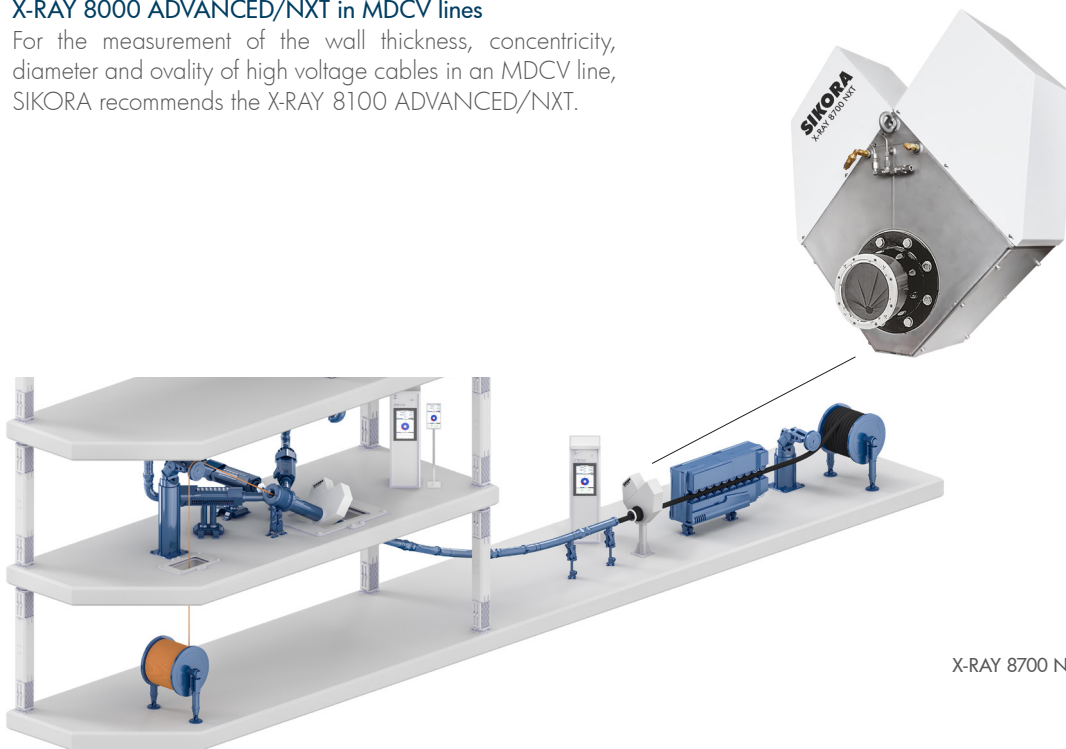

X-RAY 8700 NXT at the end of a CCV line

X-RAY 8700 NXT provides measuring values of the final product and documents the product quality

While the X-RAY 8000 ADVANCED/NXT provides information for a fast centering of the crosshead and an automatic control, the X-RAY 8700 NXT measures the final product dimensions (diameter, wall thickness, eccentricity) at the end of the production line. It is applicable for cables with solid and stranded as well as milliken conductors with single, double

or triple layer insulation. The combination of the X-RAY 8000 ADVANCED/NXT at the beginning with the X-RAY 8700 NXT at the end of the line offers a precise determination of the shrinkage values for all three insulation layers. This assures an optimum in process control.

8-point display of the wall thickness and eccentricity

The wall thickness, eccentricity, diameter and ovality are clearly visualized on a TFT monitor. An 8-point display of the wall thickness and a color highlighting of the eccentricity, together with numerical information on its angle and size, guarantee optimum process stability.

Information is displayed both numerically and graphically. The display includes a length related trend display of all values together with a graphic for the distribution curves on the single values and a comprehensive statistic with min/max value as well as average and standard deviation.



X-RAY 8000 NXT monitor image on the SIKORA ECOCONTROL 6000

NTX window (NonToxic X-ray window) and XLL X-ray tubes (eXtra Long Life)

The masterpiece of fine engineering is the use of ceramic and NTX windows (NonToxic X-ray window), which separate the scanners from the pressure of the CV line. The surface of the windows does not react with any by-products resulting from the cross-linking of the polyethylene material. As a result, the windows remain permanently clean. Thus, all systems of the X-RAY 8000 family are equipped with XLL X-ray tubes (eXtra Long Life) that contribute to a long operation time with consistent accuracy and reliability.

Technical Data

X-RAY 8000 ADVANCED/NXT

Measuring Principle

X-ray with Multi-Sensor-Technology

Application*

MV, HV, EHV cables with XLPE, EPR, EPDM, HYPALON insulation etc.

Gauge Head

Product Diameter

X-RAY 8000 ADVANCED/NXT for CCV lines	10 - 92, 130, 168 mm
X-RAY 8000 ADVANCED/NXT for VCV lines	10 - 140, 205 mm
X-RAY 8700 NXT at the end of MDCV, CCV, VCV lines	10 - 94, 145, 180 mm
X-RAY 8100 ADVANCED/NXT for MDCV lines	on demand

Accuracy

Wall thickness: $\pm 15 \mu\text{m}$, $\pm 0.02 \%$ deviation
Diameter: $\pm 5 \mu\text{m}$, $\pm 0.02 \%$ deviation

Display

22" monitor with touch screen

Interfaces (Optional)

RS485, USB, OPC DA/UA, LAN, Profinet IO, Ethernet/IP, Profibus-DP, analog outputs, digital inputs and outputs

Power Supply

230 V AC, $\pm 10 \%$, 50/60 Hz

* SIKORA also offers a product portfolio regarding inspection, analysis and sorting devices in the area of plastics. For further details, please refer to our catalog "Systems for inspection, sorting and analysis of XLPE and PP material".

3 LASER Series 2000 – Efficient diameter control at any time



LASER Series 2000

LASER Series 2000 XY models
for efficient 2-axis diameter measurement
LASER Series 2000 T models
for efficient 3-axis diameter measurement
LASER Series 2000 S/R models
for the efficient measurement of sector and round cables

Typical features

- Highest precision and reliability
- No moving parts
- No calibration
- Availability: 99.8 %

With the gauge heads of the LASER Series 2000, SIKORA offers high-quality laser technology for efficient diameter measurement, meeting the increasing demands of the cable sector in regard to quality and productivity. High precision, reliability and continuous functionality are the outstanding features of the dual and triple-axis gauge heads. Due to their functional design, the systems can easily be integrated into any production line.

The technique behind these gauge heads is a state-of-the-art CCD line sensor technology with a high pixel resolution, combined with laser diodes as light sources and intelligent powerful analysis software. The outstanding feature of the non-contact and non-destructive measuring technology is the extremely high single value precision, which is an important aspect for the calculation of the standard deviation. The short exposure time assures reliable readings at all common line speeds.



Swivel gauge head function

The LASER Series 2000 gauges are free from moving parts and have a nearly unlimited life time. Even after years of operation, the devices measure as accurately as on the day of delivery. The optical measuring principle, without any moving parts, ensures an availability of 99.8 %. Calibration or maintenance procedures are not necessary.

Specific measuring systems for every application

LASER Series 2000 XY

With the LASER Series 2000 XY, SIKORA offers efficient gauge heads for a precise diameter measurement in two planes. Innovative regarding the laser and the CCD sensor – the diameter measurement based on diffraction analysis sets highlights. This technology does neither require rotating mirrors nor optical components, is absolutely maintenance-free, does not require any calibration and offers the highest precision during the operation.

LASER Series 2000 T

The LASER Series 2000 T models are 3-axis gauge heads for precise diameter and ovality measurement that leave nothing to be desired. The focus of the 3-axis gauge heads is on defining the ovality of a product. An oval is defined by five tangents, and therefore, by using three measuring axes (six tangents on the oval) not only the min/max value of the oval, but also the orientation of the oval is defined.

LASER Series 2000 S/R

The LASER Series 2000 S/R (Sector cable/Round cable) is most suitable for the precise measurement of the height of

straight and prespiralled sector conductors as well as for round cables. The fascinating 5-axis concept of the S/R heads requires no rotation of the gauge head, and thus, no maintenance. Typically, one of the S/R gauge heads is installed before and after the extruder, whereby the average wall thickness is calculated, based on the two diameter values. For a perfection in wall thickness control, the two gauge heads are combined with the processor system ECOCONTROL 6000.

Intelligent design

Interesting is the design of the LASER Series 2000 devices for protection against contamination. The smaller gauge heads are equipped with a unique and proven multi-slot protection. The gauge heads for larger measuring ranges as well as all triple-axis and S/R devices are open at the bottom, which prevents water and dirt from falling into the measuring area.

A special feature of the larger models and 3-axis measuring heads is the swiveling gauge head design, allowing the head to be moved up and out of the extrusion line. The measuring heads are free from wearing parts, remain highly precise throughout their lifespan and do not require any calibration or maintenance.

Interfaces + Industry 4.0

The LASER Series 2000 gauges offer a maximum of flexibility regarding the interfaces and are therefore, designed for the use under the aspect of "Industry 4.0". You find an interesting range of display and control units for data collection and automatic control such as the ECOCONTROL 6000 on page 16.

Technical Data LASER Series 2000

Product Name	Product Diameter	Accuracy*	Repeatability	Exposure Time
LASER 2050 XY/T	0.5 - 50 mm	± 2.5 µm	± 0.5 µm	0.2 µs
LASER 2100 XY/T	1.0 - 100 mm	± 5.0 µm	± 1.0 µm	0.2 µs
LASER 2200 XY	5.0 - 190 mm	± 10.0 µm	± 2.0 µm	0.2 µs
LASER 2300 XY	50 - 300 mm	± 20.0 µm	± 4.0 µm	0.2 µs
LASER 2500 XY	50 - 500 mm	± 50.0 µm	± 10.0 µm	0.2 µs
LASER 2050 S/R	1.0 - 35 mm (sector)	± 20 µm	± 4.0 µm	0.2 µs
	0.5 - 50 mm (round)	± 2.5 µm	± 0.5 µm	
LASER 2100 S/R	1.0 - 35 mm (sector)	± 20 µm	± 4.0 µm	0.2 µs
	1.0 - 100 mm (round)	± 5.0 µm	± 1.0 µm	
Measuring Rate				
500/sec/axis (higher measuring rates on demand)				
Interfaces				
Serial interface RS485, setup and diagnosis interface RS232 Optional: analog output or alternatively industrial fieldbus (e.g. Profinet IO, EtherNet/IP, Profibus-DP, CANopen, DeviceNet, OPC UA)				
Power Supply				
100 - 240 V AC ± 10 %, 50/60 Hz				

* ± 0.01 % of the measured value

4 LASER Series 6000 – A milestone in diameter measurement



LASER 6080 XY

LASER 6080 XY for high-end diameter measuring in the area of Non Destructive Testing (NDT)

No other diameter gauge head attracts as much attention as the models of the LASER Series 6000. The LASER 6080 XY combines a variety of new technological features for a diameter measurement with impressive precision and reliability for sustainable improvement of the productivity and reproducibility of production processes regarding Industry 4.0.

Up to 2,500 measurements per second per axis, all with extremely high single value precision, enable an optimum line control and provide reliable statistical data.

Integrated display in the gauge head

The device includes an integrated LCD display that provides the operator with diameter values at one glance, directly at the measuring device.

Lump detector function

The high measuring rate of the diameter device also permits the detection of lumps and neckdowns. With the two-in-one system, investment costs are reduced. In addition, there is more space in the line as both functions are integrated into one gauge head.

Typical features

- Innovative CCD line sensor technology combined with pulse controlled laser diodes
- Impressive precision
- 2,500 measurements per second per axis
- Integrated LCD display
- Integrated lump detection function
- Universal interface module for all connections
- Optimum installation and protection of the connection cables
- Two-year warranty

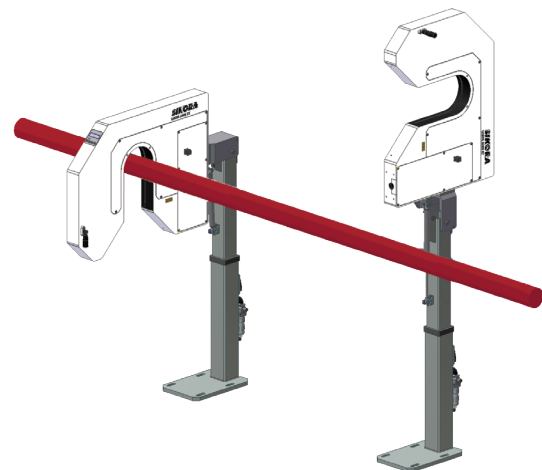

Swivel gauge head function

Functionality in perfection

A special feature of the LASER Series 6000 is the swivel type gauge head. Conveniently, the gauge head can be moved up and out of the line during production changes. The measuring heads are open at the bottom to prevent dirt and water from falling into the measuring area. The feeding of the connection cables to the interface module is protected against water, dirt and mechanical influences, directly in the gauge head stand.

The opening range of the gauge is twice as large as the measuring range, for an easy and safe passage of the product and possible joints.

Interfaces + Industry 4.0

A universal interface module is directly integrated into the gauge head for any connections such as RS485, RS232, Profibus-DP or alternatively an industrial fieldbus such as Profinet IO, EtherNet/IP, CANopen, DeviceNet or OPC UA. With these interfaces, the device series is best equipped under the aspect of "Industry 4.0".

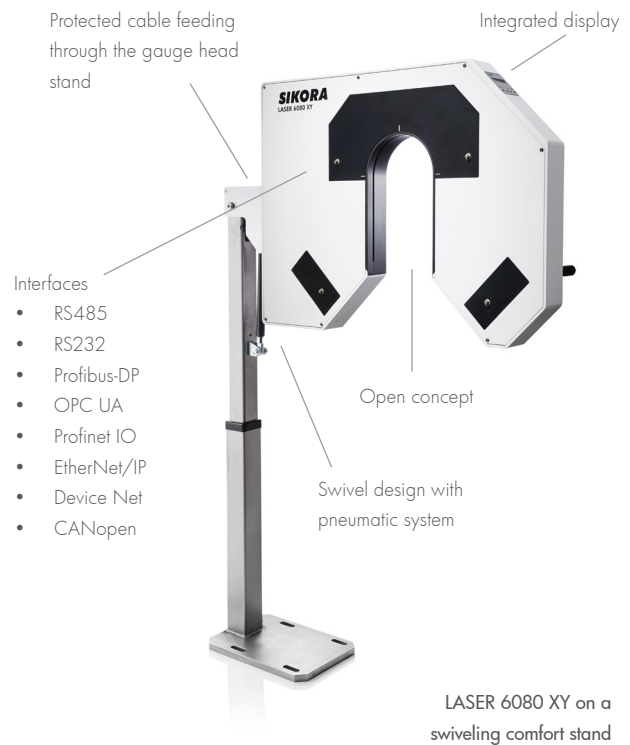

Technical Data LASER Series 6000

Product Name	Product Diameter	Accuracy*	Repeatability	Exposure Time
LASER 6080 XY	1.0 - 78 mm	± 1.0 µm	± 0.5 µm	0.2 µs
Measuring Rate				
2,500 measurements/sec/axis				
Interfaces				
RS485, RS232, LAN Optional: Analog output or alternatively industrial fieldbus (e.g. Profinet IO, EtherNet/IP, Profibus-DP, CANopen, DeviceNet, OPC UA)				
Power Supply				
100 - 240 V AC ± 10 %, 50/60 Hz				

* ± 0.01 % of the measured value

5 X-RAY 6000 PRO – Intelligent partner in high voltage lines or during the production of cables

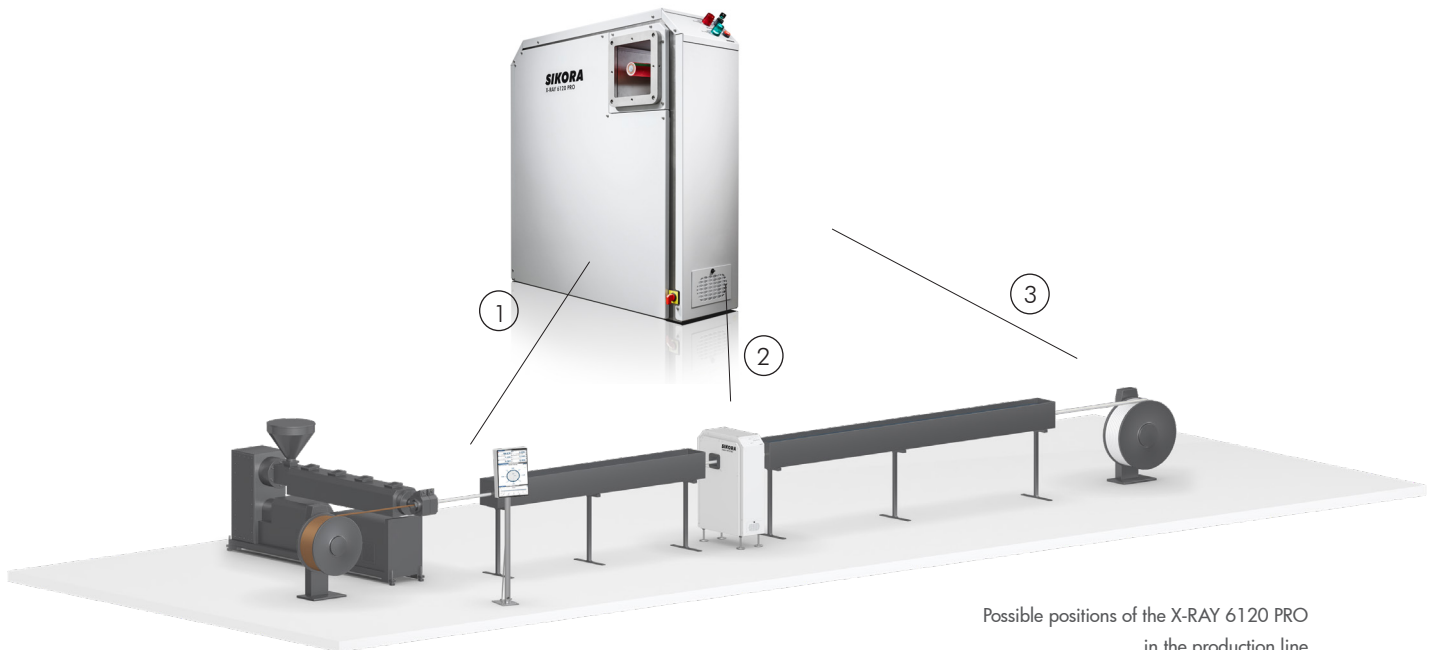

Possible positions of the X-RAY 6120 PRO in the production line

Measurement of the wall thickness, concentricity, diameter and ovality of single and multi-layer products

For quality control of cables in jacketing lines, the X-RAY 6000 PRO continuously ensures compliance with requested cable specifications regarding wall thickness, concentricity, diameter and ovality.

Sheathing lines

In sheathing lines, the X-RAY 6000 PRO is typically installed between two cooling trough sections. In this position, the device measures the outer jacket of the cable. An additional diameter gauge head is positioned at the end of the production line, combined with a Hot-Cold-Control, considers the shrinkage of the diameter.

X-RAY 6000 PRO for single and multi-layer products

The X-RAY 6000 PRO measures the wall thickness, concentricity, diameter and ovality of up to three different cable layers. Typically, it is used at tandem extrusion lines.

Safety

Concerns on the safety of X-ray devices are arbitrary, as the radiation is of no relevance because of the low energy. A human is exposed to a much higher radiation on a flight from New York to Frankfurt.

Typical features X-RAY 6000 PRO

- Measurement of the wall thickness, concentricity, diameter and ovality of up to three different material layers
- Automatic control of the line speed or extruder rpm under consideration of the minimum values
- Selectable measuring rate from 1 to 3 Hz (optional 10/25 Hz)
- 22" TFT monitor (vertical), or 15" monitor (horizontal)
- Intuitive touch screen operation
- No calibration

Display and control device ECOCONTROL 6000

The X-RAY 6000 PRO includes as a standard the display and control device ECOCONTROL 6000 with a vertically arranged 22" TFT monitor. It can be mounted on a separate stand or remotely integrated into the control cabinet of the line. The ECOCONTROL 6000 is conveniently and intuitively operated via touch screen.

Features of the ECOCONTROL 6000 at one glance:

- Line presentation with pictograms of the connected devices
- Display of the single values and eccentricity of the wall thickness incl. highlighting of the min. wall thickness in color
- Length related trend diagram with zoom function for all values
- Statistics with the minimum/maximum/mean value, standard deviation, Cp and CpK values
- Reel and length related data storage

The ECOCONTROL 6000 is most efficiently used with the automatic control of the line speed or extruder rpm under consideration of the minimum values.

Quality assurance and significant cost savings

From the very first day of operation the X-RAY 6000 PRO assures a continuous online quality control during cable production. An offline quality control is no longer necessary. Simultaneously, the system reduces the wall thickness to the smallest permissible value by taking into account the statistical fluctuation. Quality assurance and the reduction of material usage lead to a significant increase of productivity, repeatable processes and cost savings.



The production data of the X-RAY 6000 PRO is clearly displayed on the vertical 22" wide-screen monitor ECOCONTROL 6000

Technical Data X-RAY 6000 PRO

Measuring Principle

Non-contact with latest X-ray technology

Product Name	Diameter*	Accuracy
X-RAY 6020 PRO	0.65 - 15 mm	5 µm
X-RAY 6035 PRO	5.0 - 30 mm	5 µm
X-RAY 6070 PRO	6.0 - 65 mm	10 µm
X-RAY 6120 PRO	10 - 110 mm	10 µm
X-RAY 6200 PRO	20 - 180 mm	20 µm
X-RAY 6300 PRO	30 - 270 mm	30 µm

* Larger and smaller measuring ranges on demand

Measuring Rate

1 to 3 Hz (optional 10 Hz/25** Hz)

Interfaces

RS232, USB

Optional: LAN, industrial fieldbus (e.g. Profinet IO, EtherNet/IP, Profibus-DP, CANopen, DeviceNet), OPC DA/UA

Power Supply

100 - 240 V AC ± 10 %, 50/60 Hz

** For X-RAY 6035 PRO and X-RAY 6070 PRO

6 SPARK 2000 BS – Successful without breakdowns



SPARK 2000 BS

Alternating current spark tester (AC)

During the extrusion process of wires and cables, their insulation is inspected by high voltage spark testers to detect possible insulation faults and record them length-relatedly, at an early stage. For testing, the dry cable runs through the sturdy bead chain electrode of the spark tester and is exposed to the selected test voltage. This allows for quality control and ensures that only faultless cables are delivered.

SIKORA offers eight models of the SPARK 2000 BS, covering the diameter range from 1 to 200 mm. For all systems, the test voltage is continuously adjustable from 1.6 to 35 kV.

The sturdy electrode and the electronic box of the SPARK 2000 BS form one integral unit that is easy to install in new or existing lines. Optionally, the SPARK 2000 BS can be combined with the display and control device REMOTE 6000.

The REMOTE 6000 includes a display, a keypad for the setting of the test voltage, a fault counter and allows for a length related recording of the detected spark faults.

The spark tester conforms to approved test standards (AS, BS, CS, CENELEC, EN, UL, VDE) and safety regulations (as demanded by DIN/VDE 0800, IEC 479-1).

Typical features

- Reliable fault detection
- Controlled test voltage
- Fulfills all important test and safety standards

Technical Data SPARK 2000 BS

Measuring Principle	
Test device with bead chain electrode	
Gauge Head	Product Diameter
SPARK 2030 BS	1 - 30 mm
SPARK 2060 BS	1 - 60 mm
SPARK 2075 BS	1 - 75 mm
SPARK 2100 BS	1 - 100 mm
SPARK 2120 BS	1 - 120 mm
SPARK 2140 BS	1 - 140 mm
SPARK 2170 BS	1 - 170 mm
SPARK 2200 BS	1 - 200 mm
Interfaces	
RS485, RS232, electrically isolated contact, analog input and output test voltage Optional: Profibus-DP	
Test Voltage	
1,6...25 kV (30/35 kV optional)	
Power Supply	
100 - 240 V AC, ± 10 %, 50/60 Hz	

7 Partner of the measuring systems – Premium processor systems



ECOCONTROL 6000
with 22" monitor



ECOCONTROL 1000
with 15" monitor



ECOCONTROL 600
with 8.4" monitor

Premium processor systems with 22", 15" or 8.4" TFT color monitor and touch screen operation

Three ECOCONTROL processor systems form the SIKORA premium segment of display and control devices. Intelligent software technology, clear arrangements and easy usability are their appealing characteristics.

Choose the extremely innovative and powerful ECOCONTROL 6000, the unique ECOCONTROL 1000 or the smart ECOCONTROL 600. Each of these display and control systems exceeds all expectations in their class.

The innovative display of the line including pictograms of the connected devices provides a unique overview, while the numeric and graphic display of the measuring values, trend diagrams and statistics fulfill every wish regarding process visualization.

The 22", 15" and 8.4" TFT monitors and the intuitive touch screen control of the ECOCONTROL 6000, 1000 and 600 processor systems represent an intelligent and cutting edge technology.

Software packages (optional)

Automatic diameter/wall thickness control

In combination with the control module SET POINT, the ECOCONTROL systems deliver quality assurance and cost reduction. They ensure a continuous, automatic control of the diameter or wall thickness to the nominal value by controlling either the line speed or the extruder rpm.

Hot/Cold Module HC 2000 (ECOCONTROL 6000/1000)

With the Hot/Cold Module HC 2000, the material shrinkage is continuously calculated and considered automatically for the control of the diameter and/or wall thickness.

FFT analysis

Optionally, the ECOCONTROL 6000 visualizes periodical variations of the product parameter from an FFT analysis of the measuring values. This software package was developed with the support of competent partners within the industry. The FFT analysis leads to transparency of the processes, shows risks, that are caused e.g. by variations of the diameter, and indicates potential causes.

Technical Data ECOCONTROL

6000

1000

600

Display			
TFT color monitor	22" (vertical) (alternatively 15", horizontal)	15"	8.4"
Inputs/Outputs			
Serial interface RS485 for the connection to measuring devices	8*	4*	1
Electrically isolated digital inputs for the connection to testing devices	8*	4*	4*
Analog inputs 16 Bit, ± 10 V (bipolar)	8*	4*	-
Analog outputs 16 Bit, ± 10 V (bipolar)	8*	4*	-
Contact outputs for tolerance and status messages (max. 30 V, max. 0.5 A)	8*	4*	4*
Communication interface via RS232 or LAN	1*	1*	1*
Interface for printer	1*	1*	1*
Electrically isolated input for rotary pulse generators (0/15 V)	1	1*	1*
Electrically isolated interface module for control of the diameter (HC 2000)	1*	1*	-
USB customer interface	1	1	1
Industrial fieldbus (e.g. Profinet IO, EtherNet/IP, Profibus-DP, CANopen, DeviceNet)	Yes*	No	No
LAN interface (selectable OPC DA2/UA/SuiteLink)	1*	1*	1*
Wi-Fi	1*	-	-
Data Storage			
	SSD	SSD	External media*
Power Supply			
	100 - 240 V AC ± 10 %, 50/60 Hz		

* Depending on the equipment

Data storage

The data storage on a SSD medium is a standard for the ECOCONTROL 6000 and 1000. For the ECOCONTROL 600, an external media storage (USB, optional LAN) is available. Time, length or reel related production reports are available for each of the three ECOCONTROL devices (6000, 1000 and 600).

VIRTUAL 2000 – Intelligent software concept

The virtual gauge technology is suitable for all applications, which require a fast wall thickness control, but due to line configuration or the product structure, a diameter or wall thickness measurement directly after the extruder is not possible. Only

after the cooling section, that is to say in greater distance from the cross head, the real measurement is done by this technology.

The basis of the design is the simple, but sophisticated idea that an extrusion model knows the volume output of the extruder in its different operating conditions to predict with the highest accuracy the value of the produced cold wall thickness of a cable. The volume output is recorded once in a user friendly way by the ECOCONTROL 6000 in combination with the measuring device.

8 REMOTE 6000/DISPLAY 2000 – Visualization and control of production data



Standard display and control device REMOTE 6000

The REMOTE 6000 is the standard display and control device, universally applicable for all SIKORA diameter measuring devices, lump detectors and spark testers. The measuring values are displayed on a six-digit, 25 mm high, clear LED display. It is suitable for panel mounting or for assembly on the gauge head. The REMOTE 6000 includes a product library for up to 50 cable recipes. Nominal values and tolerances can easily be recalled.

Control

In combination with the control module SET POINT, an automatic control of the line speed or extruder rpm assures optimum process control and cost savings.

Interfaces

A serial interface for the connection to an external computer is standard for the collection of data or PLC line control. An Ethernet interface for PLC connection is optionally available.

LASER Series 2000/6000 with the REMOTE 6000

The REMOTE 6000 can be combined with a diameter gauge head of the LASER Series 2000/6000. The average diameter value of the connected measuring device is clearly shown on the LED display. Via a control key, the average diameter of the measuring axis x, y or the ovality is selectable on the display.

SPARK 2000 with the REMOTE 6000

Combined with the SPARK 2000, the REMOTE 6000 serves as a device for the display and setting of parameters such as the nominal test voltage. User-friendly symbols and numeric displays clearly show the current test voltage and the number of breakdowns.

Typical features REMOTE 6000

- Large, clearly arranged display and keypad
- Easy installation at any distance from the measuring head
- Automatic control module SET POINT (optional)
- Serial interface for the connection to a measuring head or a PC (optional)

Basic display device DISPLAY 2000

Interesting is the DISPLAY 2000, a display device for the combination with the SIKORA diameter measuring devices of the LASER Series 2000/6000, that shows the diameter and ovality of the measured product. It is suitable for installation in a control cabinet or at the gauge head.

Especially for applications that require a connection of the measuring system to the line control via a Profibus interface or whenever a clearly visible second display is requested, the DISPLAY 2000 is a reasonable and inexpensive supplement.

Typical features DISPLAY 2000

- Digital display
- Selectable monitoring parameter (diameter, ovality)
- Installation at any distance from the gauge head
- Serial interface for the connection to a gauge head

Technical Data REMOTE 6000

Measuring Value Display

Digital, 6-digit e.g. 000.000 ... 500.000 mm

Display Update

Programmable, factory setting 1/sec

Nominal Value/Tolerance Selection

Via keypad (operation guided via a 4-digit LED display)

Product Storage

Up to 50 product types, comfortable programming via the diagnosis software

Tolerance Message/Control Action

- In clear text on LED display
- 4 potential-free contact outputs (optional)

Interfaces

RS485 (gauge head), USB (for service)
Optional: LAN/Ethernet+UDP

Power Supply

100 - 240 V AC \pm 10 %, 50/60 Hz

Technical Data DISPLAY 2000

5-Digit Display

Digit height of 25 mm
The bright, big figures are easy to read even from a distance of 12 m

Interfaces

(Bi-directional serial interface) RS485

Power Supply

100 - 240 V AC \pm 10 %, 50/60 Hz

For your precise notes:

SIKORA

Technology To Perfection

SIKORA AG (Headquarters)

Bruchweide 2
28307 Bremen
Germany

Ph.: +49 421 48900 0
email: sales@sikora.net



Brazil

sales@sikora-brazil.com



China

sales@sikora-china.com



France

sales@sikora-france.com



India

sales@sikora-india.com



Italy

sales@sikora-italia.com



Japan

sales@sikora-japan.com



Korea

sales@sikora-korea.com



Malaysia

sales@sikora-sea.com



Mexico

sales@sikora-mexico.com



Poland

sales@sikora-poland.com



Russia

sales@sikora-russia.com



Turkey

sales@sikora-turkey.com



Ukraine

sales@sikora-ukraine.com



United Arab Emirates

sales@sikora-uae.com



USA

sales@sikora-usa.com

www.sikora.net



Certified according to
DIN EN ISO 9001

Technical data is subject to change