



Öhlins Front Fork

Motocross and Enduro

Owner's Manual



ADVANCED SUSPENSION TECHNOLOGY



Öhlins Headquarters Upplands Väsby, Sweden

Öhlins Racing AB - The Story

It was the 1970's, a young man named Kenth Öhlin spent most of his spare time pursuing his favourite sport: motocross.

Being a careful observer, Kenth's attention was continuously drawn to one specific detail - motocross bikes had more engine power than their suspension could handle. It was not long before Kenth realised that better performance could be achieved by improved wheel suspension.

Öhlins Racing was established in 1976, and just two years later the company won its first World Championship title. Despite being in the business for almost 40 years, the search for perfection and new functions is still the main focus of the company.

Congratulations! You are now the owner of an Öhlins product. More than two hundred World Championships and other major world titles are definitive proof that Öhlins shock absorbers offer outstanding performance and reliability.

Every product has gone through rigorous testing and engineers have spent thousands of hours, doing their very best to use every possible experience from our almost 40 years within the racing sport.

The product that you now have in your possession is pure racing breed that is built to withstand.

By installing this product on your vehicle you have made a clear statement... you are a serious rider with a focus on getting the maximal handling ability and outstanding feedback from your vehicle. Along comes the fact that your Öhlins product will be a long lasting friend, delivering the very best of comfort and performance every time you go for a ride. Go explore!

SAFETY PRECAUTIONS

General Warnings

Note!

The shock absorber/front fork/steering damper is an important part of the vehicle and will affect the stability.

Note!

Read and ensure you understand the information in this manual and other technical documents provided by Öhlins, before using the product.

Note!

Öhlins Racing AB can not be held responsible for any damage to the shock absorber/front fork/steering damper, vehicle, other property or injury to persons, if the instructions for mounting, usage and maintenance are not followed exactly.

Warning!

After installing the Öhlins product, take a test ride at low speed to ensure your vehicle has maintained stability.

Warning!

If the suspension makes an abnormal noise, or the function is irregular, or if you notice any leakage from the product, stop the vehicle immediately and return the product to an Öhlins dealer.

Warning!

The product warranty shall only apply if the product has been operated and maintained in accordance with recommendations in this manual. If you have any questions regarding usage, service, inspection and/or maintenance please contact Öhlins.

Note!

When working with the Öhlins product, always read the vehicle service manual.

Note!

This manual shall be considered as a part of the product and shall accompany the product throughout its life cycle.

SAFETY SYMBOLS

In this manual, mounting instructions and other technical documents, important information concerning safety is distinguished by the following symbols:



The Safety Alert Symbol means: Warning! Your safety is involved.

Warning!

The Warning Symbol means: Failure to follow warning instructions can result in severe or fatal injury to anyone working with, inspecting or using this product, or to bystanders.

Caution!

The Caution Symbol means: Special precautions must be taken to avoid damage to this product.

Note!

The Note Symbol indicates information that is important regarding procedures.

Product Specific Warnings

Warning!

This product was developed and designed exclusively for a specific vehicle model and shall only be installed on the intended vehicle model in its original condition as delivered from the vehicle manufacturer.

CONTENTS

| | |
|---------------------------------------|----|
| Safety precautions | 3 |
| Tools | 4 |
| 1 Install the Öhlins front fork | 5 |
| 2 Change spring..... | 7 |
| 3 Setup | 9 |
| 4 Measure the spring preload | 10 |
| 5 Adjustments | 11 |
| 7 Oil level..... | 12 |
| 8 Inspection and maintenance | 13 |

TOOLS

Tools needed to install the Öhlins Front Fork

See your vehicle service manual for proper instructions regarding removing and installing the front fork.

Tools needed for Öhlins Front Fork Service

| Tool | | Note |
|----------------------------|----------|------------------------|
| Fork Cap Tool | 50mm | octagon |
| Socket | 12mm | for Öhlins shaft end |
| Pliers | | for security snapping |
| Plug | 01890-01 | |
| Bushing removal tool | 01702-04 | with top part 01702-13 |
| Bushing/Seal mounting tool | 01799-04 | |

1 INSTALL THE ÖHLINS FRONT FORK

⚠ Warning!

We strongly recommend to let an Öhlins dealer install this product.

⚠ Warning!

If you work with a lifted vehicle, make sure that it is safely supported to prevent it from tipping over.

👁 Note!

When you work with this product, see the vehicle service manual for vehicle specific procedures and important data.

👁 Note!

Before you install this product clean the vehicle.

1

Place the motorcycle on a work stand so that the rear wheel barely touches the ground.

2

Remove the front wheel, plastic fork leg protectors and the brake caliper.

3

Measure the distance from the top of the upper triple clamp to the center of the front wheel axel, see figure.

Note measure

| | |
|----------------------|--|
| Fork height position | |
|----------------------|--|

4

Loosen the upper triple clamp screws.

5

Loosen the lower triple clamp screws.

6

Remove the fork legs from the vehicle.

👁 Note!

On some models you must install the Öhlins triple clamps provided in the kit. Refer to the vehicle service manual for instructions of how to remove the upper and lower triple clamp. You must remove the OEM steering stem and steering bearing from the OEM lower triple clamp and install them on the Öhlins triple clamp.

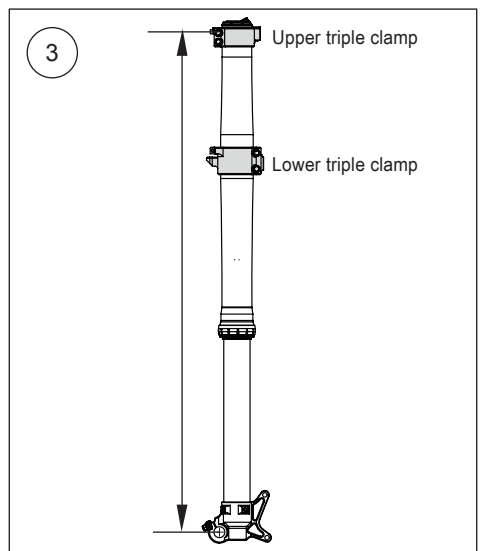
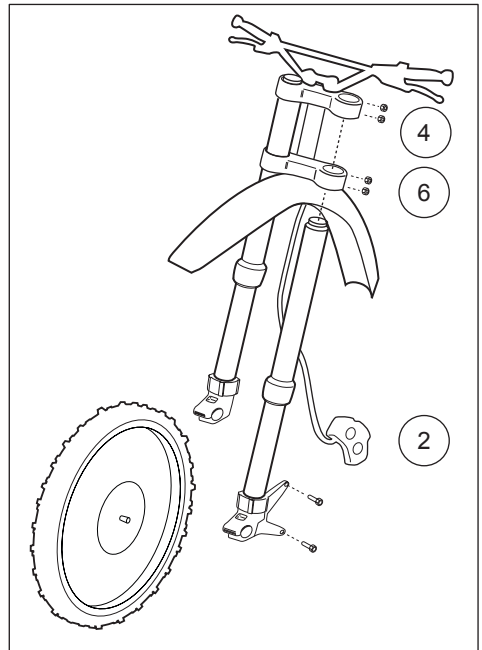

1 INSTALL THE ÖHLINS FRONT FORK

⚠ Warning!

We strongly recommend to let an Öhlins dealer remove and install the steering stem.

7

Refer to the vehicle service manual for instructions of how to install the lower and the upper triple clamp and how to get the correct steering bearing free play.

8

Install the fork legs into the triple clamps. Use, to start with, the same height position as measured in step 3. Rotate the fork legs in the triple clamps to get access to the adjusters in the fork leg top cap. We recommend to rotate the adjuster access point towards the rear of the motorcycle, the "Ö"-logo readable from riding position.

9

Place the upper fork leg sticker and insert the lower plastic fork leg protectors. Refer to the vehicle service manual to tighten the top and bottom triple clamp bolts to correct torque.

👉 Caution!

It is very important to tighten the triple clamps to the correct torque, refer to the vehicle service manual.

10

Install the brake caliper and the front wheel. Tighten the brake caliper bolts. Tighten the front wheel nut and the left side fork bottom screws. Make sure front fork legs are parallel before you tighten the right side fork bottom screws. Refer to the vehicle service manual to tighten the brake caliper and the front wheel axle to correct torque. Tighten the fork bottom M8 to maximum 15 Nm.

⚠ Warning!

Do not over tighten the fork bottom M8 screws.

11

Make sure that all removed parts are installed correctly, refer to the instructions in the vehicle service manual.

2 CHANGE SPRING

Note!

Loosen, do not remove, the top cap from the outer tube when the fork leg is still fixed by the lower triple clamp.

1

Remove the original fork legs, see chapter 1, steps 1-6.

2

Unscrew the top cap from the outer tube.

3

Use a pair of pliers to remove the security snapping at the bottom of the fork. Turn clockwise to loosen the bottom end of the cartridge kit.

4

Insert the plug (01890-01) into the fork bottom. The plug will keep the oil in the fork while you change the spring.

5

Remove the cartridge kit from the fork leg, change the spring. Note the plastic preload washer/s, if any.

Note!

Place the preload washer/s below the spring, at the bottom end of the fork leg.

6

Install the cartridge kit into the fork leg and push out the plug (01890-01).

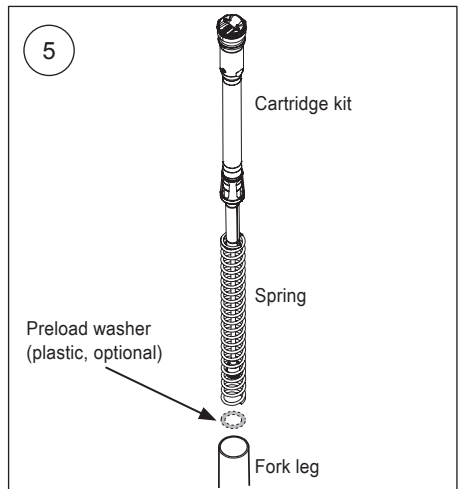
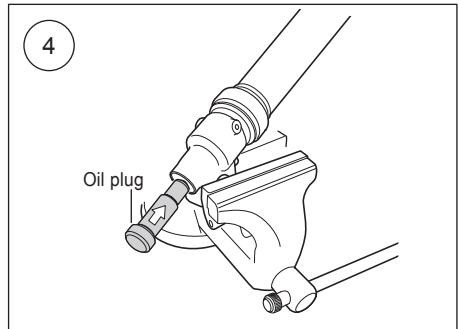
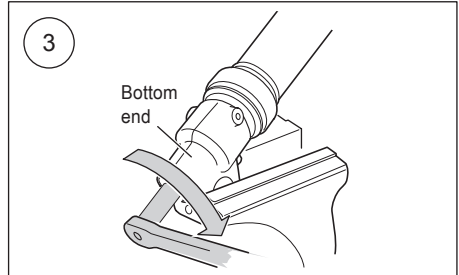
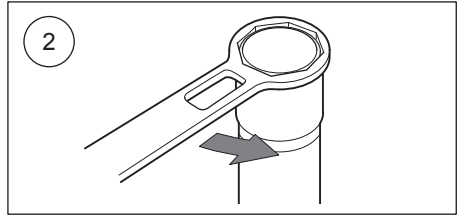

2 CHANGE SPRING

7

Apply some grease on the threads of the plug.

8

Tighten the shaft end counter clockwise into the fork bottom, tighten to 18 Nm.

9

Insert the security snap-ring.

10

Use a 50 mm octagon Fork Cap Tool to gently tighten the Öhlins fork top cap, tighten to maximum 10 Nm.

11

Install the front fork and all other removed parts according to chapter 1, steps 7-11.

Note!

Make sure to tighten the triple clamps to the correct torque.

Note!

Make sure to install all removed parts as they were before.

Note!

If you, after you have changed the spring, experience problems like bottoming or that the front fork works far down in the stroke, this may be caused by loss of oil when you changed the spring. Add Öhlins Front fork fluid in steps of 10 ml at a time until the symptoms are gone.

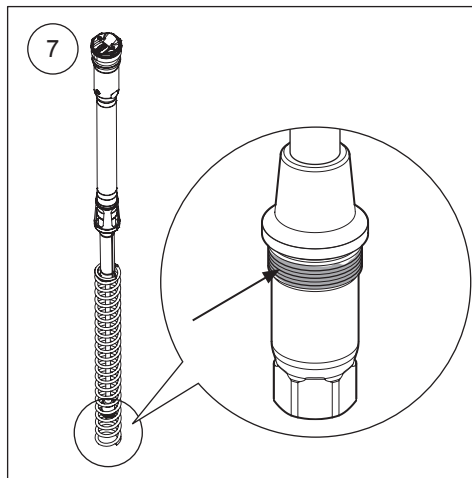

3 SETUP

Check sag and ride height

1

Work on a flat surface. Put the motorcycle on a workstand so that both wheels are off the ground and the suspension is unloaded.

2

Mark, for example with a piece of tape, a point immediately above the rear wheel axle.

3 Measure R1

Measure the distance from the marked point to a fixed point, for example the wheel axle.

4 Measure R2

Put the motorcycle on the ground so that the rear suspension is slightly compressed. Repeat the measurement process.

5 Measure R3

Sit on the motorcycle in normal riding position, properly outfitted in your riding gear. Repeat the measurement process.

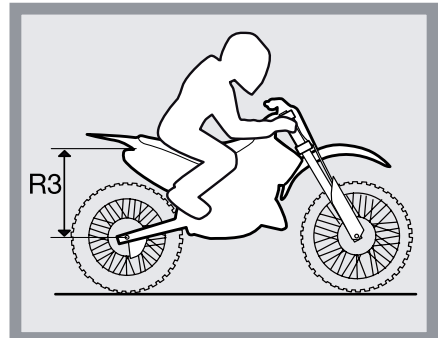
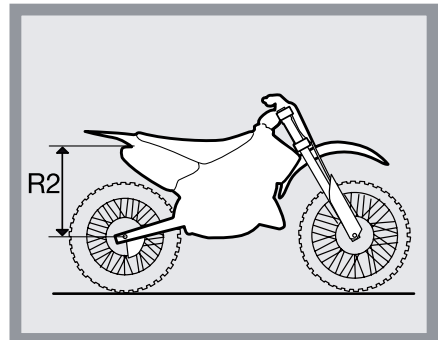
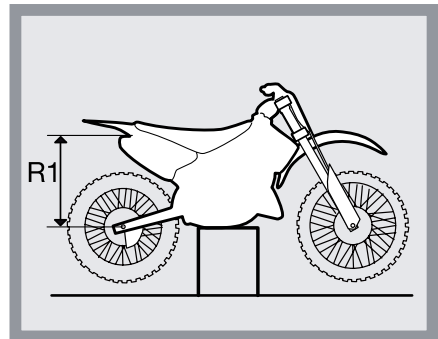

Note measures

| | |
|----|--|
| R1 | |
| R2 | |
| R3 | |

Recommended measures

See the recommended free sag and ride height measures in the Öhlins Mounting Instructions for the shock absorber or in the vehicle service manual.

If the ride height still differs from the recommendations, you may need to change spring, contact an Öhlins dealer for advice.

⚠ Warning!

Incorrect spring rate may produce a fork angle that is too steep or too flat. This in turn can lead to a tendency for over- and understeering, which could seriously affect the handling characteristics of the motorcycle.

4 MEASURE THE SPRING PRELOAD

Fork springs may differ in length. Thus we recommend to measure the preload on each fork leg and install the required preload washers to get the correct measure.

Preload less than 0 mm will make the fork springs loose when the front wheel is off the ground, which can increase the risk of wear inside the fork.

Front Forks MY 2014

Recommended minimum spring preload: 4 mm

⚠ Caution!

Preload washers must be placed below the spring, otherwise they will restrict oil flow and the fork may break.

Measure the spring preload according to the steps 1-5 and see the figure below:

1 Measure A

Fork outer tube slid down to stop

MY ≤2013: Fork outer tube slid down to stop and cartridge left with full length. The internal gas pressure extends the cartridge.

MY 2014 (MX only): The internal spring will prevent the gas pressure from extending the cartridge, thus you must extend the cartridge with your hand 0-4 mm.

2
Measure B

3
Measure C

4
Calculate preload:

$$\text{Preload} = B - A - C$$

| | Note measure |
|-----------------|--------------|
| A | |
| B | |
| C | |
| Preload B-A-C = | |

5
For recommended preload refer to the setup data in the Mounting Instructions or contact an Öhlins dealer for advice. To adjust the preload you add or remove washers below the spring.

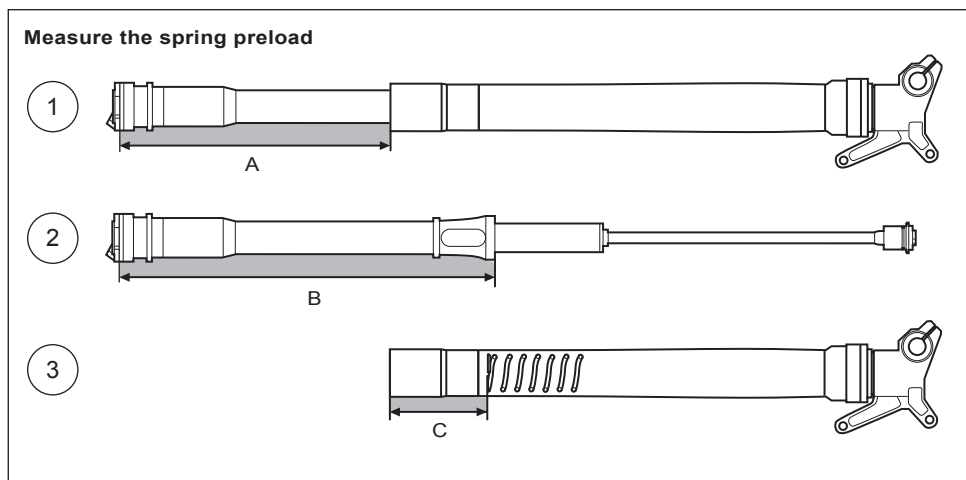

5 ADJUSTMENTS

Compression damping adjuster

Use a 3 mm Allen key to adjust the compression adjuster.

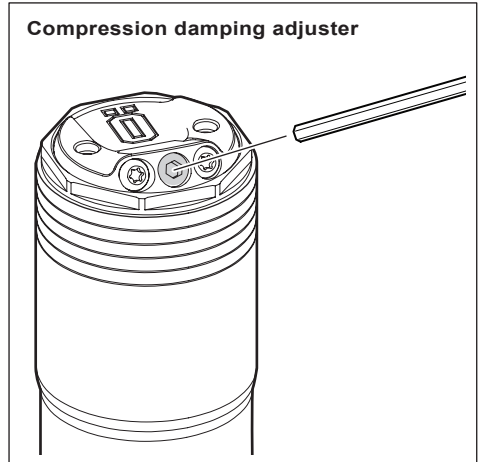

Rebound damping adjuster

Use a 3 mm Allen key to turn the rebound adjuster at the bottom of the fork leg.

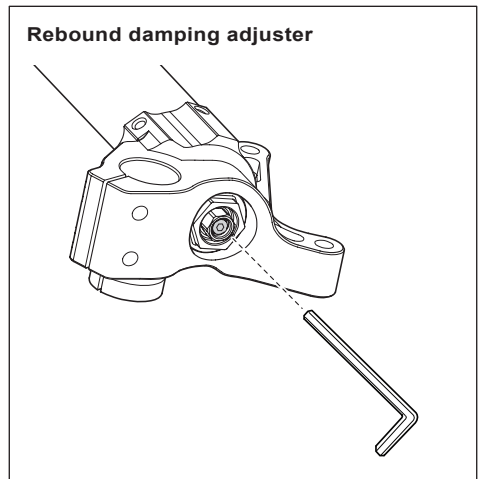

To set

The adjusters have a normal right hand thread. Turn the damping adjusters gently clockwise to fully closed (pos. zero [0]). To open, turn counter clockwise, and count the clicks until you reach the recommended number. For recommended clicks see the Setup data in the Mounting instructions or contact an Öhlins dealer for advice.

Caution!

Turn the adjusters gently not to damage delicate sealing surfaces.

7 OIL LEVEL

To set the oil level

Proper oil level is a balance between sufficient bottoming resistance and comfort. Higher oil level will give better bottoming resistance, but might reduce comfort over smaller bumps.

Bottoming issues

Increase oil level in steps of 10 ml until unpleasant bottoming no longer occurs, or until comfort on rest of the track becomes too harsh.

Harsh fork

Decrease the oil level in steps of 10 ml to gain comfort until harshness no longer occurs or bottoming resistance gets too low.

Additionally, lower oil level will let the fork dive longer into the stroke during braking before additional damping effect stiffens up the stroke, see position C in the figure below.

Very fast riders might appreciate the additional damping from a higher oil level on all parts of the track, as this keeps the fork running higher in the stroke, withstanding their additional forces due to their higher velocities.

👁 Note!

If the fork leaks, make sure to service the fork immediately, since small amounts of oil have a great influence on the performance. We highly recommend to have an Öhlins dealer service the fork. When you drain the fork, it is very important to let all oil drain out to get a proper oil level in the fork after service.

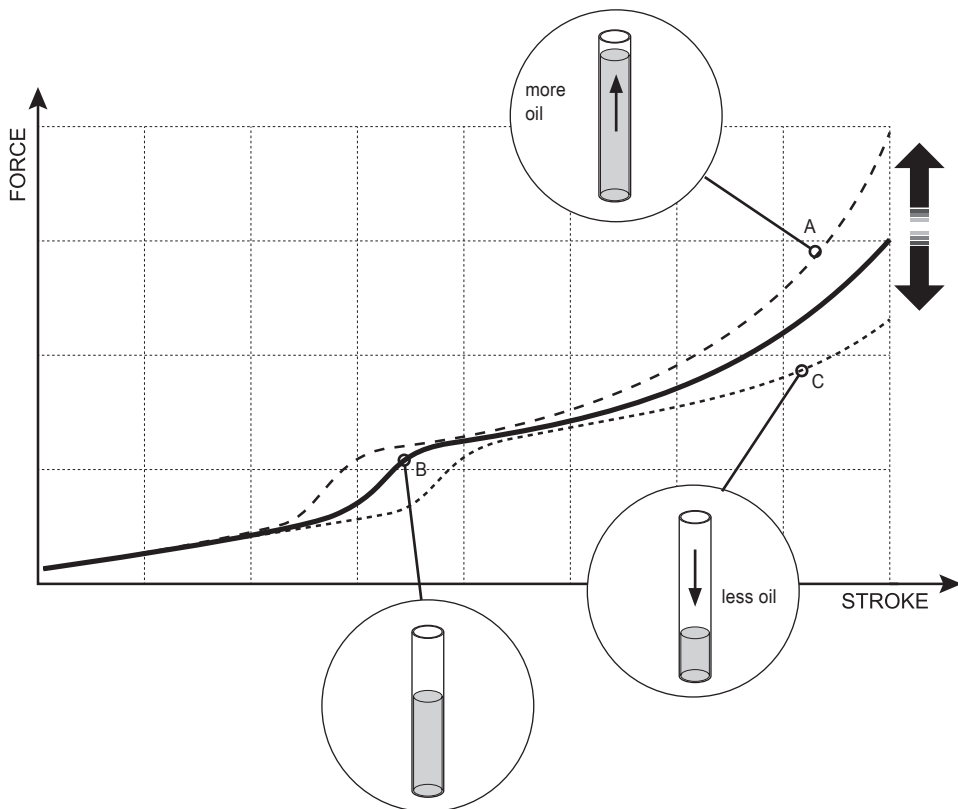

8 INSPECTION AND MAINTENANCE

Preventive maintenance and regular inspection reduces the risk of poor performance. If there is any need for additional service, please contact an Öhlins dealer.

Breather plug

Aerate the front fork at regular intervals:

1. Place the motorcycle on a work stand so that the front wheel is off the ground.
2. Loosen the Breather plug to release too much pressure in the front fork. Make sure to tighten the breather plug after.

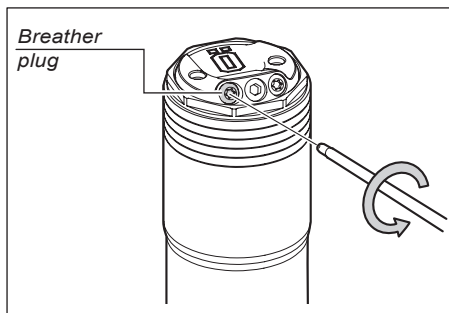

Clean the scrapers

The scrapers protect the fork tube from dust and dirt. After some use dirt may end up behind the scrapers. If this dirt is not removed the oil sealing rings may start to leak.

How to clean:

1. Lift the scrapers out of the outer tubes with a screwdriver and slide them down.
2. Clean the scrapers, the outer tubes and the inner tubes.
3. Lubricate the inner surface with a thin layer of Öhlins grease (00159-01) and Öhlins Front Fork Fluid (01309-01), leave the outside dry. Insert the scrapers into the outer tubes.

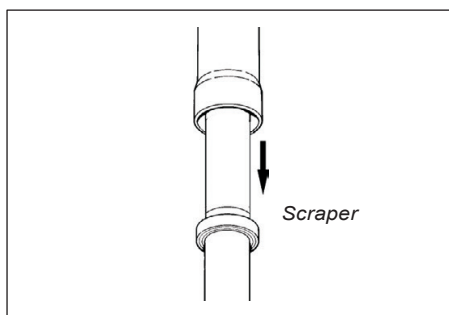

Inspect and/or replace seals and bushings

Disassemble

1

Disassemble the fork leg, see chapter 2, steps 1-4.

2

Remove the cartridge, spring and plastic preload washers, drain the front fork from all fluid.

3

Use a screwdriver to gently remove scraper and the seal circlip.

Note!

The fork legs have one fixed bushing and one sliding bushing. Be careful when you disassemble the fork legs, use bushing removal tool (01702-04).

8 INSPECTION AND MAINTENANCE

4

Fasten the fork legs horizontally in a vice with soft jaws. Apply heat with a heat gun to warm up the outer tube where the bushings are located.

5

To remove the bushings; Install the bushing removal tool (01702-04) at the top of the outer tube. Separate the inner tube from outer tube. Rotate the tool to press out the the inner tube with seals and bushings.

6

Remove the seals and bushings and examine them for wear and damage. Replace if needed.

⚠ Caution!

When you remove and install scraper and oil seal use thin plastic tape on the edges of the inner tube to prevent damage to the seals.

Assemble

7

Apply a thin layer of Öhlins grease (00159-01) and Öhlins Front Fork Fluid (01309-01) on the sealing surface of the scraper ring and the fork seal. Leave the outer surface of the scraper ring dry. Install the scraper ring, circlip, oil seal, support ring and the bushing on the inner tube.

8

Fasten the outer tube in a vice with soft jaws. Install the inner tube. Use bushing/seal mounting tool (01799-04) to install the lower bushing.

👁 Note!

Apply heat with a heat gun to warm up the outer tube before you install the bushings.

9

Use bushing/seal mounting tool (01799-04), flip it around to install the seal in the outer tube. Install the circlip and the scraper.

⚠ Caution!

Make sure to insert the circlip correctly into the groove of the outer tube.

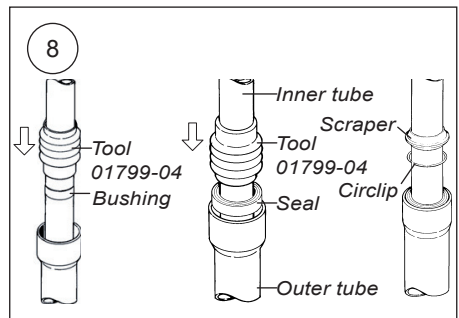
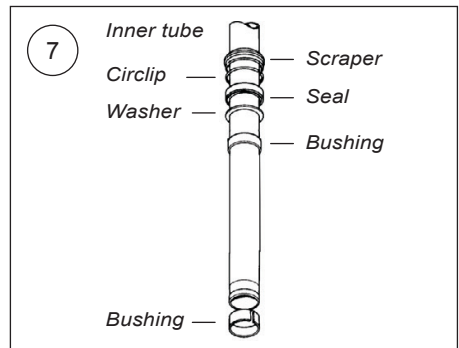
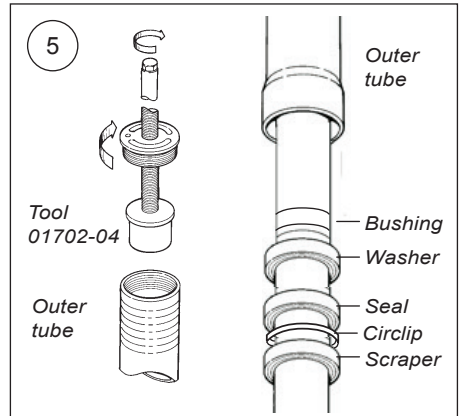
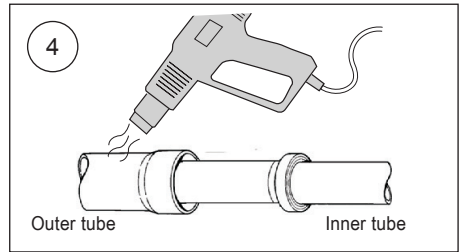

8 INSPECTION AND MAINTENANCE

Remove and inspect the cartridge, and check pressure

1

Disassemble the fork leg, see chapter 2, steps 1-4.

2

Remove the cartridge and examine for wear or damage, replace parts if needed.

Caution!

When you compress the damper cartridge fully, fluid might escape from top cap side hole.

3

Check pressure (not MY 2014, see note): Compress the cartridge fully. When you release the internal pressure should push back the cartridge to full length distinct stop.

Note!

Please note that you can not check pressure on MY 2014 products. Contact Öhlins for more information. Gas pressure check and procedures require special knowledge and tools.

Warning!

We strongly advice to let an Öhlins dealer perform service on the damper cartridge.

4

Follow the instructions from previous chapters to install the front fork to the vehicle.

Maintenance intervals

Do not use strong solvents, such as brake cleaner to clean the front fork. This will dry out the seals and the tubes and cause friction or leakage.

After every race

Clean externally and spray with an all-purpose oil after washing with detergent. Examine externally for damage.

Every 20 hours

Disassemble the fork and examine all parts for wear and damage, replace if needed.

Disposal

Hand over discarded Öhlins products to an approved Öhlins dealer for proper disposal.

Maintenance intervals

| | After brake-in | Every race | Every 20 hrs | As required |
|------------------------------|----------------|------------|--------------|-------------|
| Inspect and adjust | x | x | - | x |
| Clean and lubricate scrapers | x | x | - | - |
| Replace seal and scraper | - | - | - | x |
| Replace oil | x | - | x | - |
| Replace bushings | - | - | x | x |
| Service damper cartridge | - | - | x | x |

Your Öhlins retailer:

Öhlins Racing AB
Box 722
SE-194 27, Upplands Väsby
Sweden

Phone: +46 (0)8 590 025 00
Fax: +46 (0)8 590 025 80
www.ohlins.com



www.ohlins.com