

Home Care Provider Setup Instructions

Always use these instructions along with the User Manual when assembling or adjusting this equipment.

REMstar® CPAP System

This CPAP System is intended only for the treatment of adult Obstructive Sleep Apnea.



System Contents

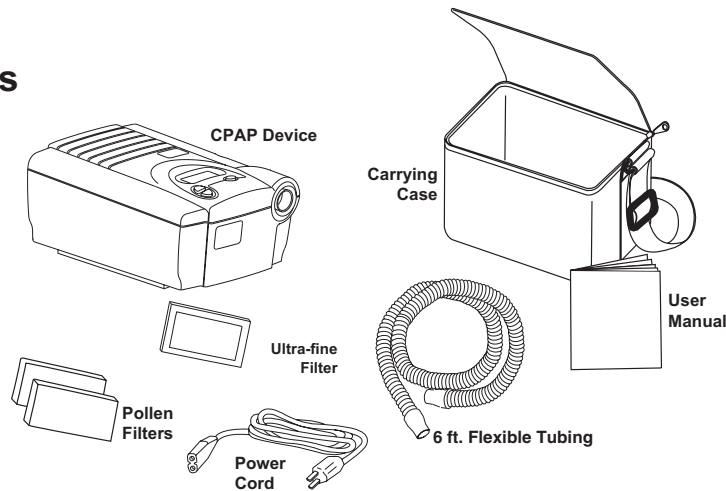

Symbols

Display Screen

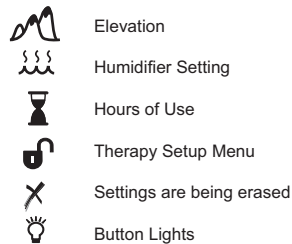

Control Buttons

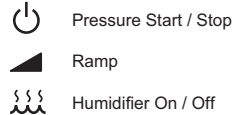

Device Label

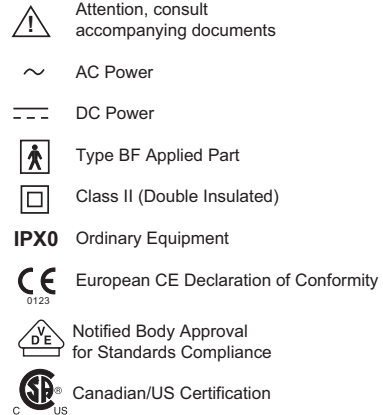

Specifications

AC Power Consumption:

100 - 240 VAC, 50/60 Hz, 1.0 A max.

DC Power Consumption:

12 VDC, 3.0 A max.

Pressure Increments:

4.0 to 20.0 cm H₂O (in 1.0 cm H₂O increments)

Degree of Protection Against Ingress of Water:

IPX0 Ordinary Equipment

Mode of Operation: Continuous

Type of Protection Against Electric Shock:

Class II Equipment

Degree of Protection Against Electric Shock:

Type BF Applied Part

Pressure Display Accuracy: +/- (0.15 + 4% of actual reading)

Sound Pressure Level: <30 dB(A)

Maximum Flow: 35 LPM

Warnings & Cautions

CAUTION!

Indicates the possibility of damage to the device.

- *US federal law restricts this device to sale by or on the order of a physician.*

WARNING!

Indicates the possibility for injury to the user or the operator.

- *This device is intended for adult use only.*
- *This device is not intended for life support.*
- *CPAP devices have the potential to induce rebreathing of exhaled air.*

To reduce this potential, observe the following:

- *Use Respironics circuit accessories.*
- *Do not wear the mask and headgear for more than a few minutes while the unit is not operating.*
- *Do not block or try to seal the vent holes in the exhalation port.*

As with most CPAP devices, at low CPAP pressures, some exhaled gas (CO₂) may remain in the mask and be rebreathed.

- *Do not use this device if the room temperature is warmer than 95° F (35° C). If this device is used at room temperatures warmer than 95° F (35° C), the temperature of the airflow may exceed 106° F (41° C). This could cause irritation to the patient's airway.*
- *This equipment is not suitable for use in the presence of a flammable anesthetic mixture with air or with oxygen or nitrous oxide.*
- *If you notice any unexplained changes in the performance of this device, if it is making unusual or harsh sounds, if it has been dropped or mishandled, or if the enclosure is broken, discontinue use. Contact Respironics Customer Service Department and replace any damaged parts before continuing use.*
- *To avoid electrical shock, disconnect the power cord before cleaning. DO NOT immerse the REMstar in any fluids.*

Contraindications

When assessing the relative risks and benefits of using this equipment, the clinician should understand that this device can deliver pressures up to 20 cm H₂O. In the event of certain fault conditions, a maximum pressure of 30 cm H₂O is possible. Studies have shown that the following pre-existing conditions may contraindicate the use of CPAP therapy for some patients:

- Bullous Lung Disease
- Pneumothorax
- Pneumocephalus has been reported in a patient using nasal Continuous Positive Airway Pressure. Caution should be used when prescribing CPAP for susceptible patients such as those with: cerebral spinal fluid (CSF) leaks, abnormalities of the cribriform plate, prior history of head trauma, and/or pneumocephalus. (Chest 1989; 96:1425-1426)
- Pathologically Low Blood Pressure

The use of CPAP therapy may be temporarily contraindicated if a patient exhibits signs of a sinus or middle ear infection. Not for use with patients whose upper airways are bypassed. Should your patient have any of these conditions, a physician will determine if CPAP therapy is appropriate.

WARNING!

Do not connect any equipment to the REMstar unless recommended by Respironics or the doctor. Verify that an exhalation port is present to exhaust CO₂ from the circuit. If circuit accessories, other than those recommended by Respironics, are connected to the REMstar, pressures must be verified. Use of these accessories may alter the pressure received, reducing the effectiveness of treatment.

Respironics Accessories

When using accessories, always follow the instructions enclosed with the accessories.

Recommended Patient Circuit

1. Respironics nasal mask with integrated exhalation port (or Respironics mask with separate exhalation port such as the Whisper Swivel® II)
2. Respironics 6 ft. (1.83 m) x 22 mm I.D. flexible tubing
3. Respironics headgear (not shown)

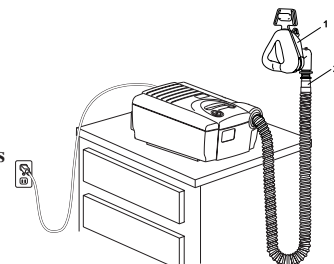

WARNING!

If this device is used for multiple persons (e.g., rental devices), a low-resistance, main flow bacteria filter should be installed in-line between the device and the circuit tubing. Pressures must be verified when alternate or optional accessories are in place.

DC Power

The Respironics DC Power Cord can be used to operate this device in a stationary recreational vehicle, boat, or motor home. The Respironics DC Battery Adapter Cable (when used with the Respironics DC Power Cord) enables the device to be operated from a 12 VDC free-standing battery.

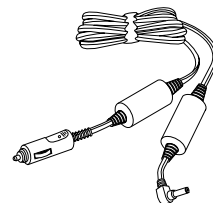

Humidifiers

The Respironics REMstar Heated Humidifier and Pass-over Humidifier are available for use with this device. The humidifiers may reduce nasal dryness and irritation by adding moisture (and heat if applicable) to the airflow. **When using other humidifiers, verify that the delivered pressure is correct and that proper therapy is being delivered. DC power cannot be used to operate the heated humidifier.**

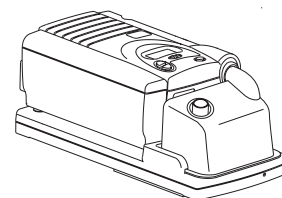

Oxygen

Oxygen may be added at the mask connection. Please note the warnings listed below when using oxygen with this device.

WARNING!

The oxygen supply must comply with the local regulations for medical oxygen.

WARNING!

A Respironics Pressure Valve (Part number 302418) must be placed in-line with the patient circuit.

WARNING!

Turn this device on before turning the oxygen on. Turn the oxygen off before turning this device off. This will prevent oxygen accumulation in the device.

WARNING!

*Oxygen accelerates fires. Keep this device and the oxygen container away from heat, open flames, any oily substance, or other sources of ignition. **DO NOT** smoke in the area near this device or the oxygen container.*

WARNING!

When administering fixed-flow supplemental oxygen, the O₂ concentration may not be constant. The inspired oxygen concentration will vary depending on the CPAP settings, patient breathing pattern, and leak rate. Substantial leaks around the mask may reduce the inspired oxygen concentration to less than the expected concentrations. Appropriate patient monitoring should be implemented.

System Setup

Filters

Install the filters.

CAUTION!

The pollen filter must be in place at all times when the REMstar is operating. The white ultra-fine filter is optional and can be used in addition to the pollen filter. The ultra-fine filter is recommended for people who are sensitive to tobacco smoke or other small particles.

1. If you are using the ultra-fine filter, place one of the pollen filters over the ultra-fine filter.
2. Insert the filter(s) into the filter area on the back of the REMstar. An extra filter is included for the patient's convenience.

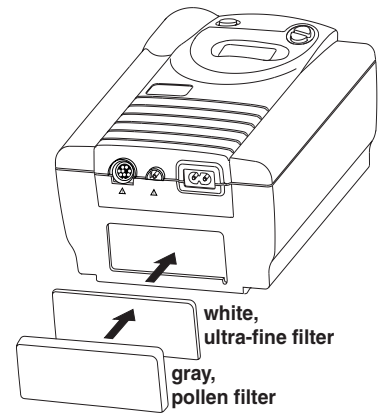

CAUTION!

If this device has been exposed to either very hot or very cold temperatures, allow it to adjust to room temperature before beginning the following setup procedures.

Control Panel

Display Screen: All device settings will appear here.

Pressure Start/Stop Button: Use this button to turn start or stop the airflow. DO NOT start the airflow until the circuit tubing is connected.

Humidifier Button: Use this button when the optional REMstar Heated Humidifier has been prescribed. This button will turn the humidifier on/off and control the heat setting. Follow the instructions included with the humidifier.

Ramp Button: Use this button to start the ramp cycle (which lowers the airflow pressure).

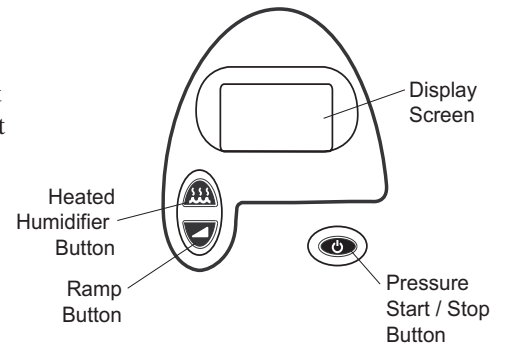

Ramp

The ramp pressure and time settings are fixed. When the airflow is turned on and the ramp button is pressed, the airflow pressure will decrease to 4 cm H₂O and then will gradually increase (ramp) up to the prescribed pressure setting over the next 20 minutes.

IMPORTANT!

When the device is in the Therapy Setup Menu, the humidifier and ramp buttons operate as up and down keys to change the settings. The pressure start/stop button will take you to the next screen.



Therapy Setup Menu

1. Plug the pronged end of the power cord into an electrical outlet. To enter the Therapy Setup Menu, hold the ramp and pressure start/stop buttons down while plugging the power cord into the device. The airflow will automatically start, and the display screen will show the current elevation setting and the unlock symbol.

IMPORTANT!

Prescribed therapy settings can be set only using the Therapy Setup Menu. To prevent patients from tampering with the settings, do not reveal the directions to access the Therapy Setup Menu.

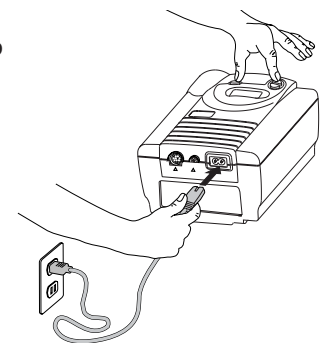

Elevation Setting

- a. **The elevation setting will appear.** *The patient also has access to this setting in the Patient Setup Menu.*

Lo or 1 = less than 2,500 ft. (< 762 m)
 M or 2 = 2,500 to 5,000 ft. (762 m to 1524 m)
 Hi or 3 = 5,001 to 7,500 ft. (1525 m to 2286 m)

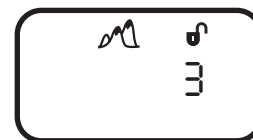

NOTE: *Elevations of 7,500 ft. (2,286 m) may affect the accuracy of the pressure. Verify the pressure settings with a water column manometer.*

To change the setting, press the ramp or humidifier button until the correct setting appears.

Press the pressure start/stop button to go to the next setting.

Pressure Setting

- b. **The CPAP pressure setting will appear.**

Range: 4 to 20 cm H₂O (in 1 cm H₂O increments)

To change the setting, press the ramp or humidifier button until the correct pressure appears.

Press the pressure start/stop button to go to the next setting.

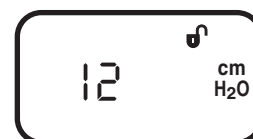

Fine Adjustment Setting

- c. **The CPAP fine adjustment setting will appear.** This setting allows you to calibrate the device so that the pressure setting can be verified with a manometer. *Range: -1.5 to 1.5 cm H₂O (in approximately 0.1 cm H₂O increments)*

If you do not want to calibrate the device, press and release the pressure start/stop button to go to the next setting.

If you do want to calibrate the device, follow the directions below:

1. Connect the patient circuit to the REMstar. Make sure there is an exhalation leak in the circuit.
2. Zero the manometer, and connect the manometer at the patient mask. Make sure the pressure has stabilized for at least 60 seconds.
3. If the pressure setting is not the same as the manometer reading, press and release the ramp or humidifier button to change the setting.

Press the pressure start/stop button to go to the next setting.



Reset Device Usage Hours

- d. **The REMstar stores and displays device usage hours and blower hours.**

Blower Hours Time is the total number of hours the REMstar has been in use. This total includes factory testing time. When the power cord is plugged in, this total will appear for a few seconds. This total cannot be reset to zero.

Device Usage Hours is the total number of hours the patient has run the REMstar. This total will appear on the display screen whenever the airflow is turned off. (The power cord must be plugged in.) For multiple patient use, this total can be reset to zero in the therapy setup menu.

To erase the totals and go back to zero, press and hold the ramp or humidifier button. An "X" will appear under the hourglass symbol. Hold the button down until the "X" disappears.



System Setup & Service

Button Lights

- e. **The button lights setting will appear.** This setting allows you to have the lights behind the buttons turned on or off while the airflow is turned on. (The lights will always be on when the airflow is off.) *The patient also has access to this setting in the Patient Setup Menu.*

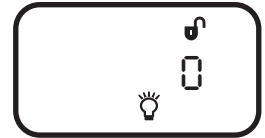

I = on

O = off

To change the setting, press the ramp or humidifier button.

Exit Settings

- f. **The settings are complete.** To repeat the settings, press the pressure start/stop button.
To exit the Therapy Setup Menu, hold the pressure start/stop button down and press the ramp button one time. The airflow will turn off.

2. Final Steps

- a. Follow the instructions in the User Manual to install the filter.
- b. Fill out the information form in the front of the User Manual. Review the User Manual with the patient.

Service

The REMstar system does not require routine servicing. If the REMstar begins to malfunction, refer to the “Troubleshooting” section of the User Manual or contact Respironics, Inc. Repairs and adjustments must be performed only by trained personnel fully acquainted with this equipment. Service performed by unqualified personnel or installation of unauthorized parts could cause personal injury, invalidate the warranty, or result in costly damage.

Disposal

When necessary, dispose of the REMstar and accessories in accordance with local regulations.

If you need product assistance, call

Respironics Customer Service Department

1-800-345-6443 (within the U.S.A and Canada) or 1-724-387-4000



RESPIRONICS®
1001 Murry Ridge Lane
Murrysville, Pennsylvania
15668-8550 USA

RESPIRONICS®
Deutschland
Gewerbestrasse 17
82211 Herrsching Germany



1018876
HM 1/23/04