

Hongkong Zhuhai Macao Bridge Link in China

Stretching the limits of Immersed Tunnelling

Mr. Su Quanke, HZMB Administrative Authority, China, sqk@hzmba.com

Mr. Chen Yue, HZMB Administrative Authority, China, cy@hzmba.com

Mrs. Ying Li : Tunnel Engineering Consultants (TEC), China, y.li@TEC-tunnel.com

Mr. J.C.W.M.(Hans) de Wit : Tunnel Engineering Consultants (TEC), The Netherlands, h.dewit@TEC-tunnel.com

1. Introduction

The construction of the HZMB Immersed Tunnel is scheduled to commence early 2011 as part of more than 50 km Link between Hong Kong, Macao and the Mainland China. It will carry a three-lane dual carriageway with a design speed of 100 km/h and is designed for a 120 year design life. With a length of approximately 6 km the immersed tunnel will become the worlds' longest. To accommodate the passing of 300.000 tons vessels the tunnel will approx. 30 m (tunnel roof) below sea level, being one of the deepest in the world.

2. Immersed tunnel design

2.1 Structural design

The immersed tunnel can be considered as one of the most challenging parts of this project and special in a number of ways. The structural design of the immersed tunnel is determined by various boundary conditions. Since the tunnel has to carry a three lane dual carriageway the spans within the cross section are relatively large with 14.55m. As explained earlier the tunnel is placed deep under the existing seabed to allow for the future deepening of the shipping channel to accommodate passage of 300.000 tons vessels. Until the future navigation channel is dredged, the immersion trench is allowed to fill with sedimentation up to the existing sea bed, which may result in a ground cover on the tunnel of over 20 m. When also taking into account the varying and poor soil conditions at the project location the cross section design in reinforced concrete becomes critical, however still feasible. The option of transverse post tensioning has been studied, but was not preferred due to a more complicated execution of the works.

The geotechnical conditions at the project location are unfavourable and have an significant impact on the immersed tunnel design. Although the immersed tunnel can be applied in relatively poor soil conditions additional measures are required over a large part of the immersed tunnel alignment due to settlement/deformation requirements. In the deep sections the geotechnical conditions are relatively good and additional measures are not required. The immersed tunnel is founded on a gravel bed direct on the existing soil. To limit settlements and more important differential settlements the additional measures have been taken by means of sand replacement, settlement reduction piles and foundation piles.

2.2 Offshore conditions during transport and immersion

The immersed part consists of 33 tunnel elements, of which most have a length of 180 m. With the cross sectional dimensions of 11.5 * 37.95 m the elements will become the largest concrete tunnel elements in the world. The tunnel elements will be built in a construction dock located at some 10 km of the project site, and will be transported and immersed under offshore conditions. During these stages adverse wave conditions may be encountered.

2.3 Artificial Islands

At the transition from the tunnels to the bridge parts artificial islands are constructed. The land reclamation for these islands is carried out in relatively soft soil conditions. For the design the very soft top layers are replaced by sand; the underlying soft layers are treated by means of sand compaction piles. The transition between the artificial island, where extensive land reclamation will take place (loading situation) and the immersed tunnel, where substantial dredging will be carried out (unloading situation), is quite complicated from a design point of view. For the detailed design it has been advised to combine 3D geotechnical modelling with an extensive monitoring to support / confirm design decisions.

2.4 Tunnel Installations and Road Safety

The development of an integral safety concept of a bridge-tunnel link of this size is a true challenge. Especially when three different governments are involved and several design companies have participated in different parts of the project. For the tunnel an integral safety concept has been developed using advanced design approaches resulting in efficient ventilation systems, safety provisions and escape procedures, also taking account the human factor (behaviour and response of the road users). In addition for maximum availability of the tunnel state of the art traffic management systems and tunnel installations will be applied.

2.5 Durability and Operation & Maintenance

The design life of the civil works of the tunnel has been defined as 120 years. Considering the severe marine environment, this can be regarded as a challenging requirement. For the concrete works special studies have been carried out using the Duracrete design method for concrete mixes and concrete covers. In addition an Operation and Maintenance Strategy has been developed that is intended to be in balance with the detailed design, allowing for easy accessibility, inspection and maintenance and therefore results in a maximum availability of the tunnel.

2.6 Conclusions

Over the last decade the fields of application of immersed tunnels have been considerably enlarged. The HZMB Link in China is the latest example, even more stretching the limits and being an example of the wide possibilities of immersed tunnelling.



Fig. 1 Project location

China's Hong Kong Zhuhai Macao Bridge (HZMB) Link Stretching the limits of Immersed Tunnelling

Mr. Su Quanke, HZMB Administrative Authority¹⁾, China, sqk@hzmba.com
Mr. Chen Yue, HZMB Administrative Authority¹⁾, China, cy@hzmba.com
Mrs. Ying Li : Tunnel Engineering Consultants (TEC)²⁾, China, y.li@TEC-tunnel.com
Mr. J.C.W.M.(Hans) de Wit : Tunnel Engineering Consultants (TEC)²⁾, The Netherlands, h.dewit@TEC-tunnel.com

¹⁾ HZMB Administrative Authority is responsible for the development, realisation and operation of the Main Bridge project.

²⁾ Tunnel Engineering Consultant (TEC) provides the HZMB Administrative Authority with international specialist support regarding the design, construction, and operation & maintenance of the tunnel (in-situ and immersed) and the artificial islands

Summary

Currently the Hongkong Zhuhai Macao Bridge Link is under construction. This major infrastructural project can be considered as one of the most challenging projects at this moment in this field of expertise. Especially the tunnel part is extending the possibilities of immersed tunnelling for the near future. The tunnel will be placed at a very deep level, and consequently has to accommodate large water and ground loads. Combined with the varying soft soil conditions and adverse marine environment and taking into account the offshore conditions for transport and immersion, this meant that advanced design approaches were to be applied in order to satisfy the various design requirements, including the 120 years design life. In addition for this project an integral traffic management system and road safety strategy had to be developed, resulting in state of the art safety measures and tunnel installation and traffic systems.

Keywords: Immersed tunnel, foundation treatment, offshore transport and immersion, artificial island, ventilation design, durability, 120 years design life

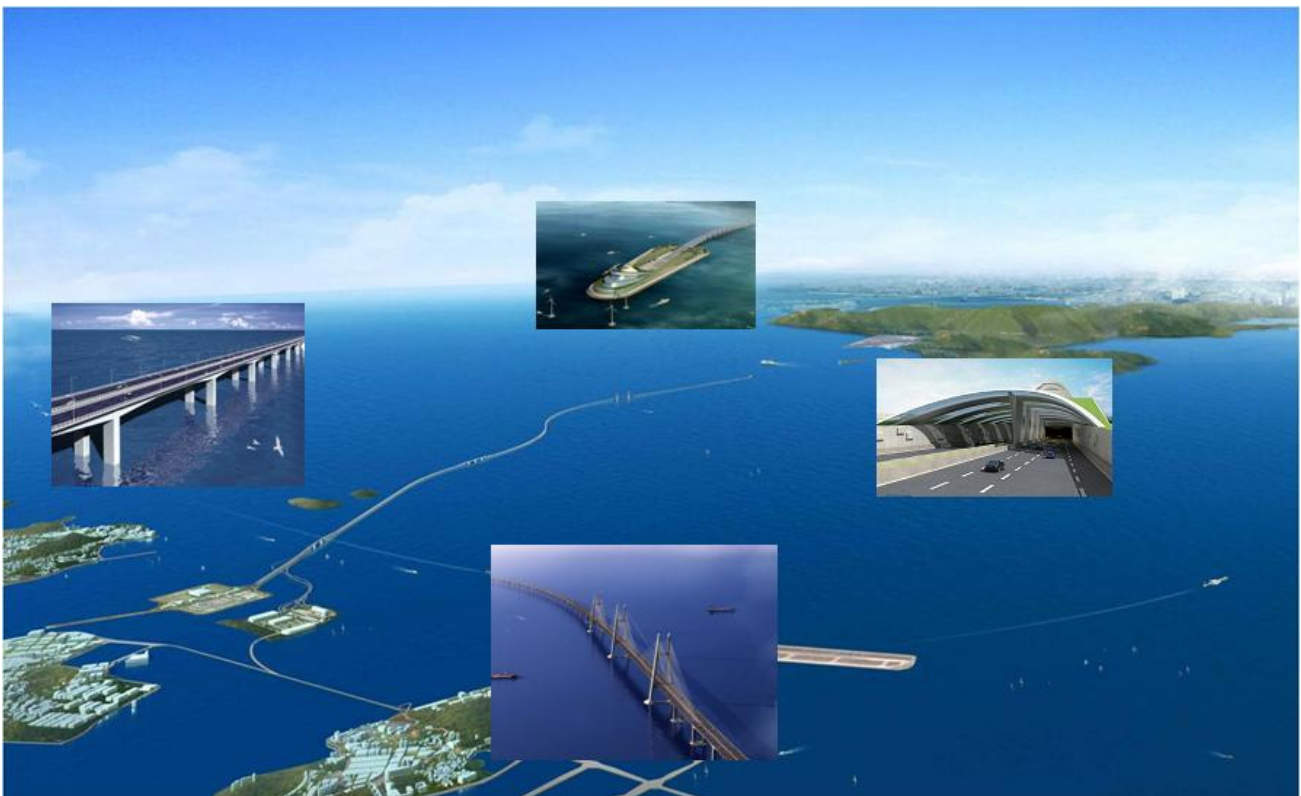

Fig. 1 Project Location

1. Introduction

The Hong Kong – Zhuhai – Macao Bridge (HZMB) Link is one of the largest ever realized. The Link comprises various bridges, causeways, artificial islands and tunnels and measures over 50km in total. The development and realization of the Link involves various projects including the so-called Main Bridge project, the Zhuhai Link Line, the Zhuhai/Macao Boundary Control Facility (BCF) Island (which is under construction since December 2009), the Hong Kong BCF Island and the Hong Kong Link Line (refer Figure 2 for an overview).

The Main Bridge project covers the main offshore section of the HZMB Link, crossing the Pearl River Estuary from the border with Hong Kong to the Zhuhai/Macao BCF. The Main Bridge project includes several causeway sections with various major (cable-stayed) bridges to accommodate passage of sea going vessels. Also included in the Scope of the Main Bridge is the crossing of the main shipping channels at the eastern side of the Pearl River Estuary that are used by 300,000DWT tankers. The crossing of these channels will be realised using a 6-km long immersed tunnel. To accommodate the transition from the bridges to the tunnel, artificial islands will be realised.

The immersed tunnel is a key element of the whole HZMB project, not only because of its relative depth (at some 40m below sea level) and length (some 6km) but also due to the adverse conditions that are present which poses specific challenges to the design of both the immersed tunnel sections and the interfaces with the in-situ tunnel sections that will be realised at the artificial islands. This paper will address the key elements and conditions of the immersed tunnel and the adjoining artificial islands. The information is based on the preliminary design that has been completed in 2010. Realisation of the tunnel and the islands is scheduled to commence in early 2011.

2. Challenging Design of the immersed tunnel

2.1 Introduction

The Main Bridge project has a length of approx. 29.6 km; the tunnel section is 6.75km and the causeways and bridges cover a length of 22.9 km. The two artificial islands that will be constructed for the transition between the bridges and the tunnel are each approx. 625m long.

The tunnel and bridges will accommodate a dual carriageway with 3 traffic lanes in each direction.

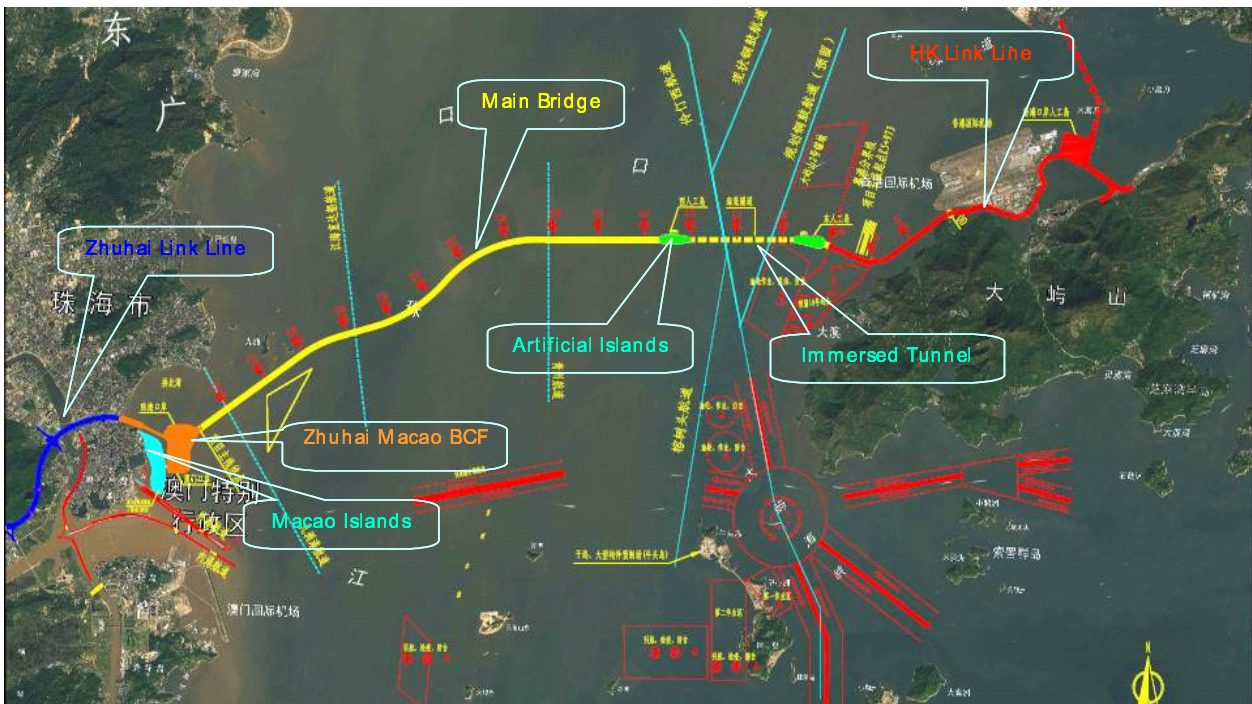

Fig. 2 Plan view of the HZMB Link

The main reasons for selecting the immersed tunnel option (over a bored tunnel option) were the poor geotechnical conditions with related risks and the wide 2*3 lane road layout that had to be accommodated with an adequate operational safety level. It was concluded that a immersed tunnel will perform better than the bored tunnel under these specific circumstances.

As per preliminary design, the immersed tunnel section measures 5.664m, the cut and cover tunnel sections on the eastern and western artificial islands 163m and open ramps on the islands 398m, making the total tunnel length equal some 6.75km.

The tunnel cross section comprises two traffic tubes (a separate tube for each traffic direction) and an escape / service gallery in between the traffic tubes. A plan view and the longitudinal profile and longitudinal section of the tunnel are shown in Fig. 2 and Fig. 3 respectively.

2.2 Structural Design of the tunnel

2.2.1 Special boundary conditions for the tunnel design

Geotechnical conditions

For the structural design of an immersed tunnel the soil-structure interaction is essential. It is of utmost importance for the design to obtain a clear understanding of the geotechnical conditions in order to identify potential risks and to enable identify potential design optimizations. Based upon the available geotechnical data it was concluded that the ground conditions at the project location (tunnel and artificial islands) are relatively poor, whereas the ground profile varies considerably over a relatively short distance.

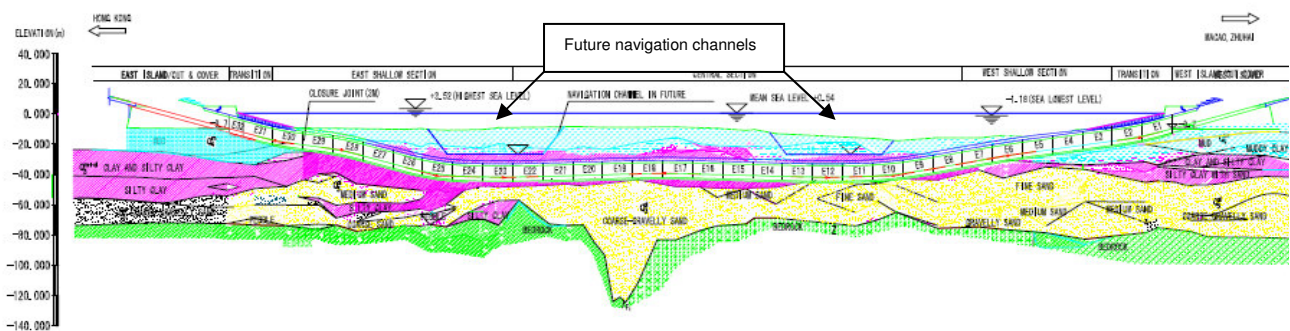

Fig. 3 Indicative geotechnical profile

The seabed level in this area varies between -8m and -15m. Holocene deposits of a thickness from 10-25 m are found below the seabed. These soils consist of muck, mucky clay and mucky clay mixed with sand and can be classified as very soft, highly compressible and normally consolidated. Under the Holocene deposits Late Pleistocene are found, with a thickness that varies between 37m and 102m (locally). The Pleistocene deposits appear to be over consolidated and mainly consist of clay with thin layers of loose to medium dense silty sand, silty clay and sand and gravel. The sand and gravel generally underlay the cohesive soils. Underneath the Pleistocene deposits rock / granite is encountered.

Accidental loads

For the HZMB tunnel a number of accidental loads had to be considered, such as:

- Explosion / implosion in one traffic tube; a static equivalent load of 100kPa is taken into account
- A sunken ship load representing a general cargo ship, resulting in a uniform load of 95kPa
- A fallen anchor load, based upon a 300.000DWT oil tanker (weight anchor 22 ton, impact velocity 9 m/s), resulting in a 133kPa distributed load acting on the tunnel roof over an area with a radius of approx. 6m
- Extreme high water and wave; high tide level with return period of 1000 years is approx. +4.2m
- Seismic events

Special attention has been given to the seismic events. Immersed tunnels have been built with success in areas with severe seismic activity. Earthquakes can impose deformations and section forces (shear forces and bending moments) to the tunnel in both transverse and longitudinal direction, as well as axial differential movements and rotations in the tunnel joints. The project area can be considered as an area with light to moderate seismic activity. Based upon the codes and Seismic Assessment report the main seismic cases to be considered are as follows:

- Design earthquake 1 (may take place several times during the tunnel design life time), with a 63% exceeding probability in 120 years; corresponding with a Peak Ground Acceleration (PGA) of 52.9cm/sec^2 . This load case is considered in SLS/ULS and has to be accommodated by the tunnel without any damage.
- Design earthquake 2, with a 10% exceeding probability in 120 years (return period 1140 years); corresponding with a Peak Ground Acceleration (PGA) of 147.5cm/sec^2 . This load case is considered as an accidental load. A level of minor repairable damage is acceptable for this kind of seismic event.

2.2.2 Structural Design in transverse direction

Although the structural design is developed integrally and interactively, in the following sections the design is described in the two main directions, the transverse and the longitudinal direction.

As indicated earlier the structural tunnel design includes special features, of which a number will be described below. The dimensions of the cross section structure are determined by the following aspects:

- (1) Large spans due to road design
Since the tunnel has to accommodate a three lane dual carriageway, the cross section of the tunnel includes relatively large spans, i.e. distance between the walls, of 14.55 m
- (2) Water depth
The tunnel is placed at a deep level (29 m below the lowest design sea level) to allow the future passage of 300.000 tons oil tankers. The two future navigation channels will have a total width of 2.810 m (see figure 3), whereas the tunnel roof will be at -30.18m.
- (3) Ground cover on the tunnel
Since the navigation channels will only be dredged in the future the immersion trench is allowed to fill with sedimentation up to the existing sea bed level, which means a ground cover that can exceed 20 m.
- (4) Ground conditions
The ground conditions are relatively poor. Over a considerable part of the tunnel alignment cohesive soils exist with time dependent settlements next to the tunnel due to the back fill and sedimentation exceeding the original stress level (loading situation) and time dependent heave below the tunnel base, where the stresses stay below the original stress level (unloading situation). This means that various relatively adverse ground support scenarios had to be considered e.g. in which the ground support at the outer walls may be absent (see figure 4). To overcome / reduce these geotechnical complications, ground improvement has to be carried out over a large part of the tunnel alignment (see section 2.3).
- (5) Ability to float
The fact that the tunnel element must be able to float during transport and immersion stages implies that there are limitations to the structural dimensions as they determine most of the weight of the (floating) tunnel.

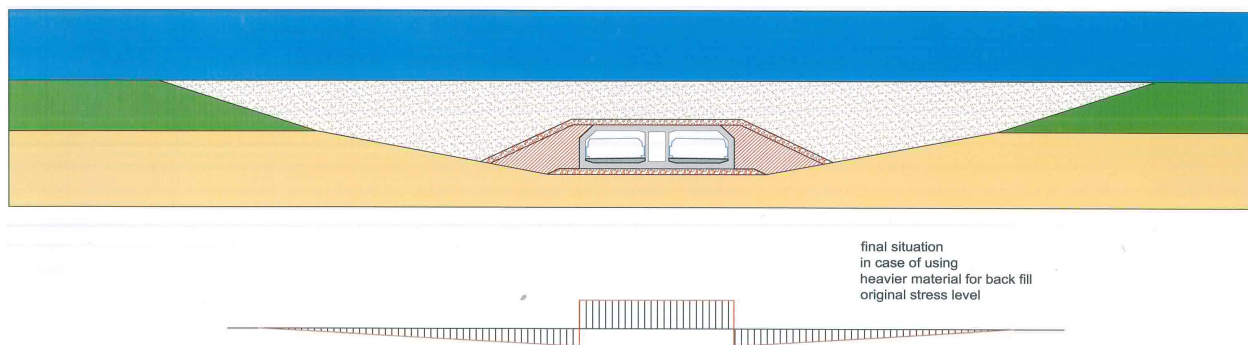

Fig. 4 Indicative stress levels at cross section

The combination of the above aspects means that the limits of feasibility of the conventional reinforced concrete option are close by. Various studies have therefore been carried out in which

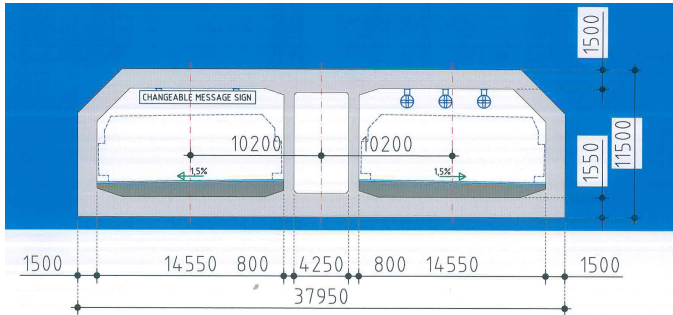

Fig. 5 Cross section of tunnel element

the conventional reinforced option was compared to an option with post tensioning in transverse direction (in roof and base slab). Finally it was concluded that the conventional reinforced option was still feasible under the conditions and was preferred because of its favourable construction aspects. For the post tensioning option a lot of temporary provisions would have to be made and a relatively complicated rebar detailing around the anchorages would be required. The dimensions of the tunnel cross-section when considering the conventional reinforced option are shown in figure 5.

2.2.3 Structural design in longitudinal direction

For the longitudinal design of concrete immersed tunnels in general two options can be distinguished: the segmental tunnel and the monolithic tunnel.

In case of a monolithic tunnel the individual tunnel elements are continuous. Between the various concrete pours construction joints are provided capable of absorbing normal and shear forces and bending moments.

In case of a segmental tunnel a tunnel element consists of several segments of 20-25 m. The joints between the segments (segment joints) allow for deformations in longitudinal direction and rotations in both the horizontal and vertical plane. Shear keys are provided in the joints to avoid discontinuous displacements over the joints in both horizontal and vertical direction. In order to make the segment joints watertight provisions are required (e.g. rubber water stops). The segmental tunnel option is widely used in Europe.

In the table below a general comparison is made between the monolithic and segmental tunnel.

Table 1 Comparison element types

Aspect	Element type	
	Monolithic tunnel (rigid)	Segmental tunnel (flexible)
Longitudinal reinforcement	Large amount	Minor
Crack control	Not easy to control (waterproofing membrane required)	Easy to control (artificial cooling may be required - staged construction)
Temporary prestress (transport and immersion)	No	Yes
Differential settlement / uneven tunnel support	- introduction of internal forces (large bending moments and shear forces) - large variations can be accommodated - for large variations in soil properties shear key design in immersion joint may be critical - limitation element length	- good adaptability - introduction of shear forces in segment joints - for large variations in soil properties shear key design in immersion and segments joints may be critical
Variation in surcharge loads - ground loads, sunken ship loads etc.	- introduction of internal forces (large bending moments and shear forces) - large variations can be accommodated - for large variations in surcharge loads shear key design in immersion joint may be critical - limitation element length	- good adaptability - introduction of shear forces in segment joints - for large variations in surcharge loads shear key design in immersion and segments joints may be critical
Seismic events	Moderate to heavy earthquakes can be accommodated. Additional requirements in immersion joints may be required.	Small to moderate earthquakes can be accommodated. Additional requirements in immersion and segment joints may be required.
Number of elements / element length (number of elements = number of influences on navigation channels)	47 pieces / 125 m	33 pieces / 180 m

For the design in longitudinal direction both the segmental option and monolithic option were thoroughly studied. The reason was that a straightforward selection for the longitudinal design was not obvious, since both options had advantages and disadvantages under the given particular

project conditions. The following aspects were considered:

- (1) Geotechnical conditions (including variation)
- (2) Surcharge loads (magnitude and variation)
- (3) Accidental loads such as seismic events and sunken ships
- (4) Internal forces (bending moment, shear forces etc.)
- (5) Construction cost

As indicated earlier the geotechnical conditions vary along the alignment and can be described as moderate to relatively soft. In the table below the influence of the foundation stiffness and variation is presented in general terms.

Table 2 Influence of tunnel foundation / sub ground

Tunnel Structure	Tunnel foundation		
	Soft Foundation (little variation)	Soft Foundation (large variation)	Stiff foundation (any variation)
Monolithic tunnel (rigid)	Follow settlements	Support on hard points	Foundation bed is governing
	Large settlements	Large average settlements	Small settlements
	Small joint rotations	Small joint rotations	Small joint rotations
	Small bending moments	Large bending moments	Small bending moments
Segmental tunnel (flexible)	Follow settlements	Follow settlements	Foundation bed is governing
	Large settlements	Large uneven settlements	Small settlements
	Small joint rotations	Large joint rotations	Small joint rotations
	Small shear key loads	Large shear key loads	Small shear key loads

To improve the settlement behaviour and to limit the internal forces in both the segmental and monolithic tunnel option soil improvement was required over a considerable part of the tunnel (see section 2.3).

Based upon the various studies that have been carried out it was concluded that the segmental tunnel was more economical and feasible given the adverse geotechnical and surcharge conditions and able to absorb the design forces due to the seismic events. Especially the heavy longitudinal reinforcement, the waterproofing membranes and the larger number of transport and immersion operations caused higher cost for the monolithic tunnel option.

For the segmental tunnel the joints are identified as the most critical items. Several designs have been considered. In all design options heavy steel or concrete shear keys were required. For water tightness purposes a double seal was selected. Shear keys are situated in the outer walls to accommodate the impact of variation in tunnel support and surcharge and seismic loads. In the roof and base slab shear keys are applied to absorb the horizontal seismic shear forces.

The immersion joint between the different tunnel elements is provided with a traditional Gina and Omega layout for water tightness and with a shear key arrangement similar to the segment joints. To accommodate the joint movements related to the seismic events a large Gina gasket is used and post tensioning cables are provided.

2.3 Foundation design

The structure - soil interaction is one of the governing factors in immersed tunnel design. The foundation design of an immersed tunnel involves the foundation bed that is installed between the tunnel structure and the original soils.

The foundation bed is required because dredging accuracies generally do not meet the structural limitations related to uneven tunnel support and differential settlements. A foundation bed can be installed after a tunnel element is placed, in which case a sand flow bed is realised (mainly for river crossings, no seismic effects). In this case the tunnel

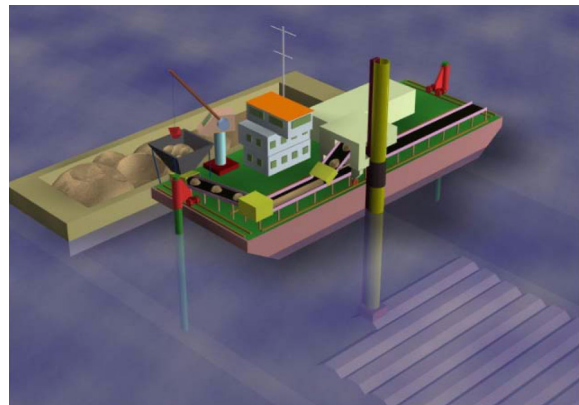

Fig. 6 Gravel bed installation

element is first placed on temporary supports that are removed afterwards. An option that is most applied in case of an offshore tunnel and when moderate or heavy seismic events need to be considered is a gravel bed. A gravel bed can be installed in berms and with a high accuracy from a pontoon (by means of fall pipes) in advance of the tunnel element immersion (figure 6). This method is applied at the Oresund tunnel and the Busan Geoje tunnel and is also considered for the HZMB tunnel.

As indicated in section 2.2.2. ground treatment is required over a considerable part of the tunnel alignment. The objective of the ground treatment is to improve the foundation conditions for the tunnel. In this way the settlements and differential settlements can be limited and therefore also the internal forces in the tunnel. In addition ground treatment is applied to promote smooth transition from one tunnel part (e.g. piled cut and cover tunnel at the islands) to the other (e.g. immersed tunnel). Two design approaches were adopted for this project:

- (1) Improvement of the ground properties in terms of strength and stiffness and to increase the uniform behaviour of the ground.
 - Replacement of soft soils by means of sandy gravels or gravel
 - Settlement Reduction Piles in soft cohesive layers (no end bearing!)
 - Cement deep mixing piles in soft cohesive layers
 - Sand compaction piles
- (2) Foundation piles on bearing ground layers in case the ground is too weak or too unpredictable (close to the artificial islands where large reclamations are carried out – see section 2.4)

In table 3 and figure 7 the various types of ground treatment are presented that are proposed for this project.

Table 3 Ground treatments applied at HZMB tunnel

Section	Section at island head	Western transition section	Western slope section	Middle section	Eastern transitional section	Section at island head
Corresponding elements (180 m)	E1	E2-E3	E4-E6	E7-E24	E25-E32	E33
Treatment method	Driven piles (end bearing)	Settlement reduction pile(driven)	Sand replacement	Direct foundation	Settlement reduction pile(driven)	Driven piles (end bearing)

The soil investigation used for the current design was relatively limited. Based upon this investigation, design assumptions had to be made that in most cases can be considered as safe upper bound approaches. That means that it is likely that optimizations are possible in the ground treatment design (resulting in saving construction costs and relaxation on the project schedule), but that at the same time it is still possible that additional measures are necessary if assumptions made appear to be too optimistic.

In the next (Detailed Design) phase an extensive soil investigation is planned that is supposed to provide a better insight of the soil profile and properties, that will make it possible to assess the risks involved in a better way and introduce design optimizations, where relevant. Amongst others, the geotechnical investigation will include Cone Penetration Tests, Standard Penetration Tests and Vane Shear Tests, Borehole testing to get (undisturbed) samples for laboratory tests and soil classifications etc. The investigation will be more concentrated in areas where most uncertainties exist (e.g. transition area between the immersed tunnel and the artificial islands). In this way the geotechnical conditions and variation can be determined more accurately and the design can be modified / optimized accordingly.

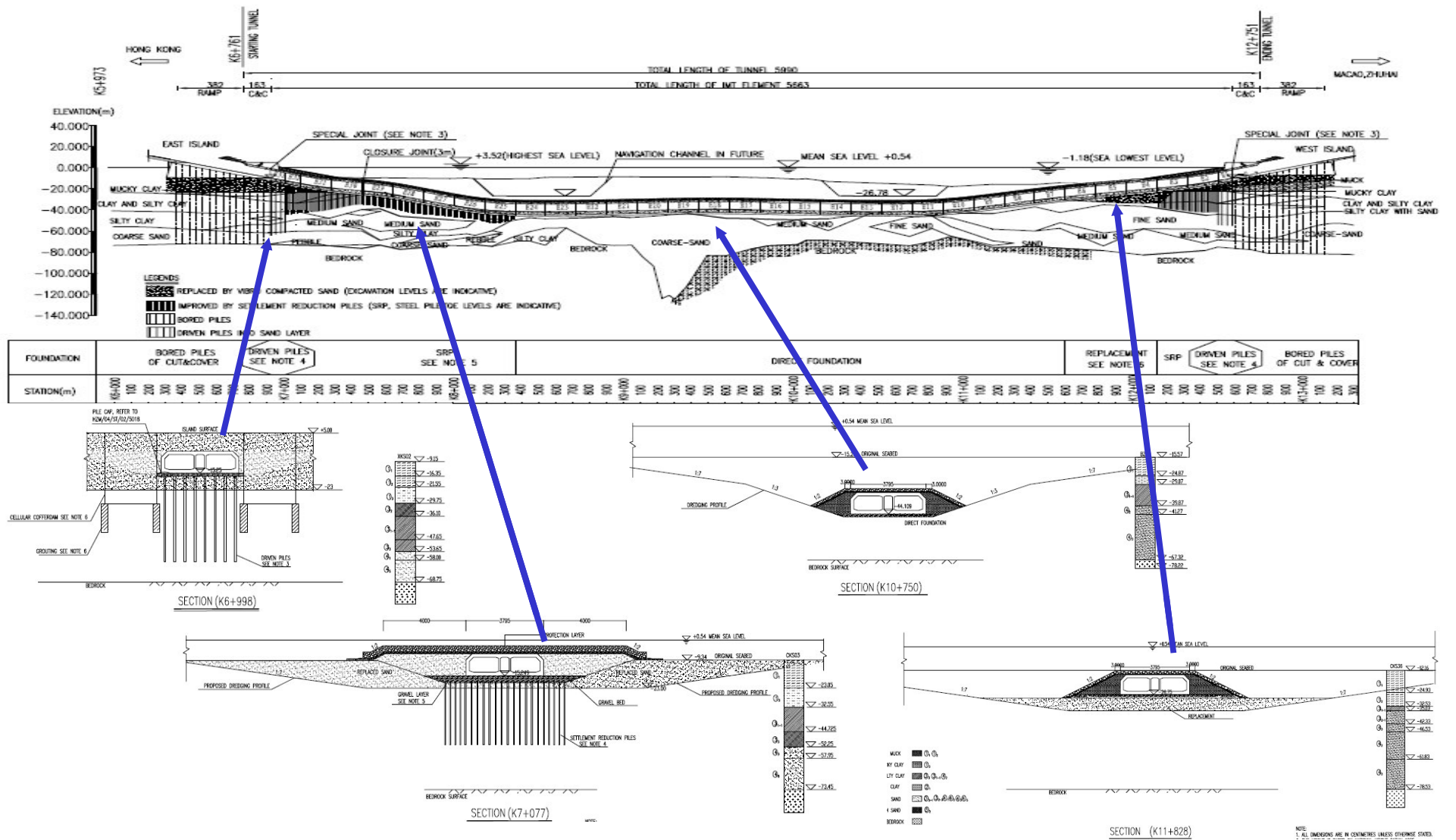

Fig. 7 Ground treatment along tunnel alignment

2.4 Transport and immersion

2.4.1 introduction

The immersed tunnel elements (180*38*10m) for this project are currently the largest ones in the world, which has to be transported afloat and immersed in offshore conditions. The transport and immersions stages are essential for the tunnel element design and this implies that the risks that are involved need to be identified and assessed and that preventive or corrective measures have to be defined in an early stage. In the passed project phase serious attention has been paid to this important part of the immersed tunnel design, since it can influence design decisions and construction progress significantly. Therefore it is very important to apply a risk based approach in making the design decisions. This amongst others includes the selection of the tunnel element production location, the element type selection (monolithic, segmental), the acceptable design wave and wind climate conditions and many others. Constant considerations between costly measures and acceptable risk levels have to take place. As an example can be mentioned the approach of having a very costly tunnel element that basically can accommodate any wave and wind climate or have the more economical tunnel element that is suitable for a more limited spectrum of wave climates, but extended with a reliable weather and wave climate forecast model.

2.4.2 Production facility of the tunnel elements

The location of the production facility of tunnel elements is very important since the transport distance and the possible wave and wind conditions are important to the design in terms of feasibility, risks and construction costs. Therefore potential casting facilities have been identified and studied. One of the most favourable locations is Guishan Island only approx. 10 km away from the project location (see figure 8). However, the island is relatively isolated and supply of power, fresh water and raw material is a point of attention, the distance is quite small and the available water depth sufficient for the transport of tunnel elements with a draught of over 10 m.

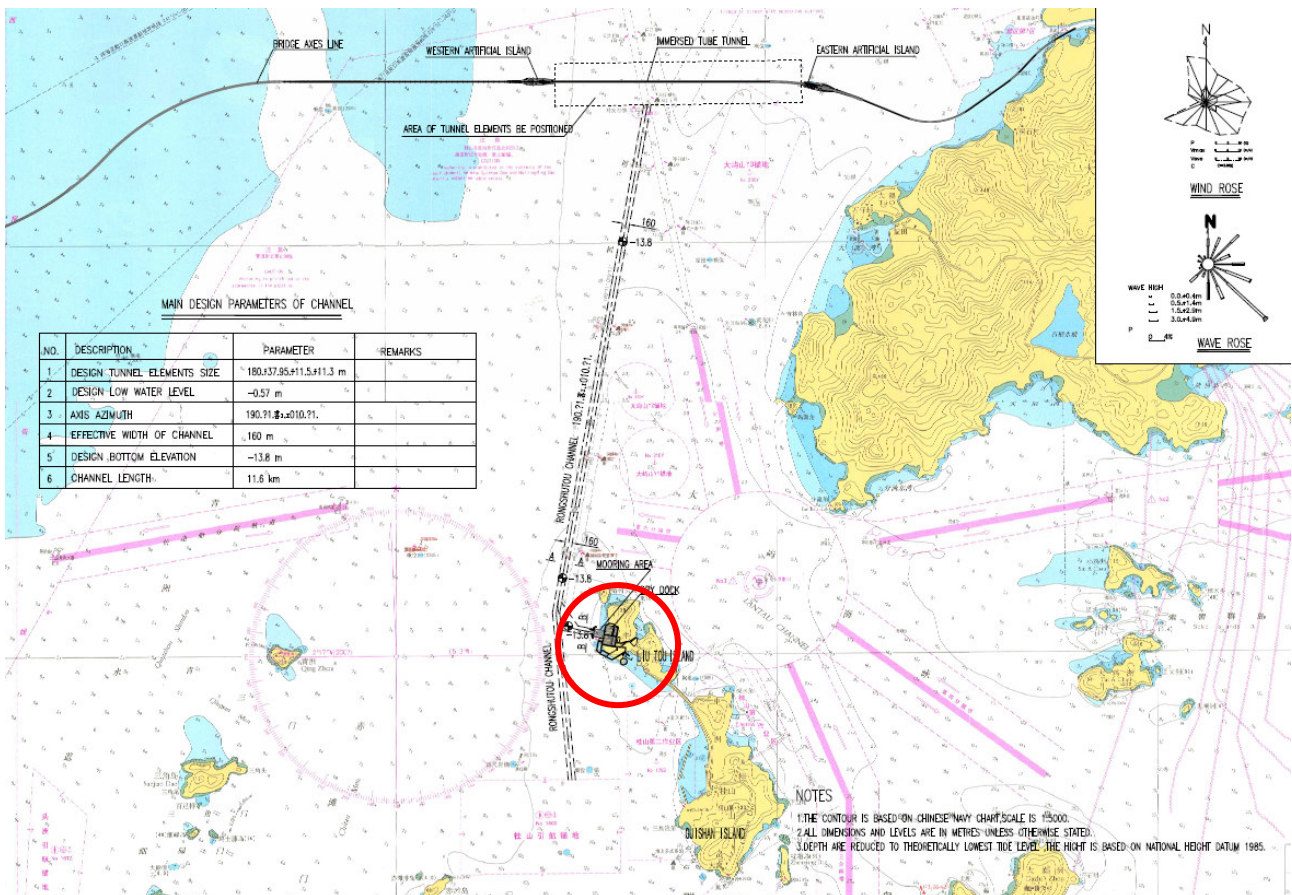

Fig. 8 Location of Fabrication Facility at Guishan Island

For the production of the elements both the traditional dry dock method and the factory method using full sectional casting (as applied the Oresund tunnel between Denmark and Sweden) were studied.

2.4.3 Design forces during transport and immersion

For the transport and immersion design of the immersed tunnel elements it is very important to have a clear view of what design forces (bending and torsional moments, shear and normal forces) have to be accommodated for the transport and immersion stages and how vertical stability (e.g. sinking, uplift) can be guaranteed during all construction phases. Since there is a large dependency on the shape and dimensions of the tunnel elements, the local wave and wind conditions, the water depths during transport and at the immersion location and since dynamic influences are involved in depth studies need to be carried out. As was done for similar projects, for the HZMB tunnel it was decided to develop an advanced numerical model in combination with physical model test. In the first stage the numerical model is used to identify critical design issues. This information can be used to define and set up the physical model test programs in the second stage. Thereafter the numerical models can be validated against the test results and used for various parametric studies (e.g. variation in wave conditions) and alternative execution stages. In this way the design forces envelopes and the stability parameters can be determined, that can be used for the transport and immersions design. In figure 9 the physical model test for a transport and immersion stage are shown.

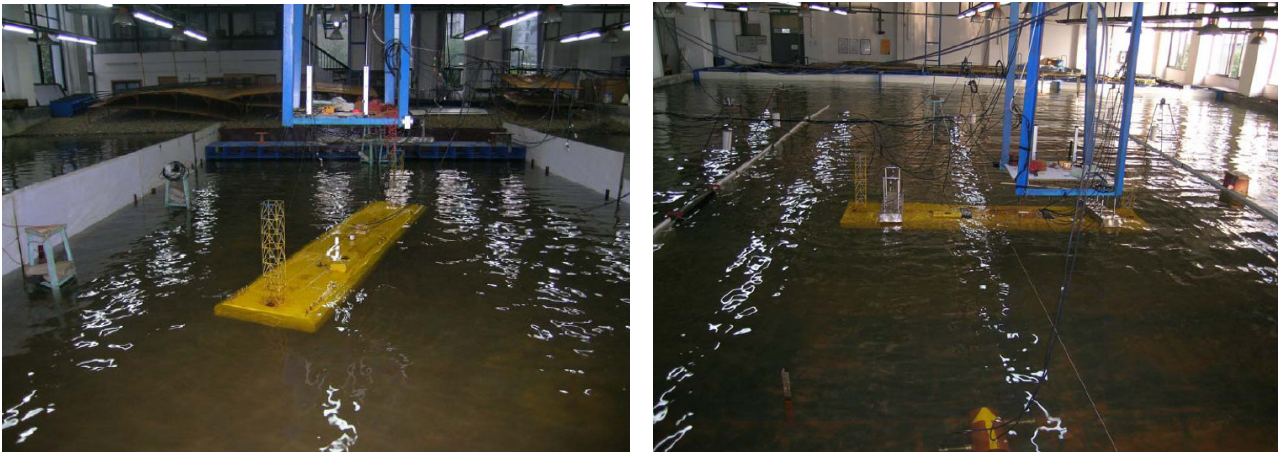

Fig. 9 Physical model test of transport and immersion phase

2.4.4 Design philosophy for transport and immersions / Wave, current, weather forecasting

Developing an optimal transport and immersion design means that a balance needs to be obtained between structural capacity (quality), acceptable risks and costs. A tunnel element that is required to accommodate (practically) all wave and weather conditions may be structurally not feasible or extremely costly. Therefore a design philosophy will be applied in which use is made of a decision model based upon a wave forecast system, in which numerous wave data are collected. More location related data can be collected by means of wave riders. With these data and the weather forecast a go / no go decision can be made for every transport and immersion operation, thus limiting risks and enabling design optimization. This approach was successfully applied at Busan Geoje in South Korea (see figure 10).



Fig. 10 Transport and immersion Busan Geoje (Photo Mergor)

3. Artificial Islands and transition to tunnel

3.1 Introduction

In the HZMB Link the transition between the bridges and the immersed tunnel will be realized by means of artificial islands. The islands are approximately 625 m long and 160 m wide. In the (architectural) design and shape of the islands account has to be made for environmental impact (islands located in reserve of the protected white dolphin), navigation aspects (islands are at the boundary of the main navigation channels), aviation aspects (close to Hong Kong Airport), hydraulic blocking effects in the Pearl River Delta, etc. At the islands also the technical service buildings for the tunnel are located. In figure 11 the general lay out of the islands is presented.



Fig. 11 Impression of artificial island and tunnel entrance

3.2 General design concept of artificial islands

As for the tunnel the geotechnical conditions for the construction of the artificial islands is not very favourable (also see section 2.2.1). Since large land reclamations and extensive back fill operations are involved the geotechnical design is quite delicate in order to meet the settlement/deformation requirements that were defined. Therefore the following concept has been developed:

- Excavate soft top layers of mud
- Sand compaction piles to improve underlying cohesive layers (depending on back fill levels)
- In fill with coarse sand to be compacted
- Formation of the sea defence walls consisting of rock or stone layers and revetments of doloses
- Install circular sheet piles walls or diaphragm walls as retaining structure for the cut and cover tunnels (on some locations also to serve as part of the sea defence in the final phase)
- Construct cut and cover tunnel founded on bored piles
- Finishing works

A typical cross section to explain the basic principles is presented in figure 12.

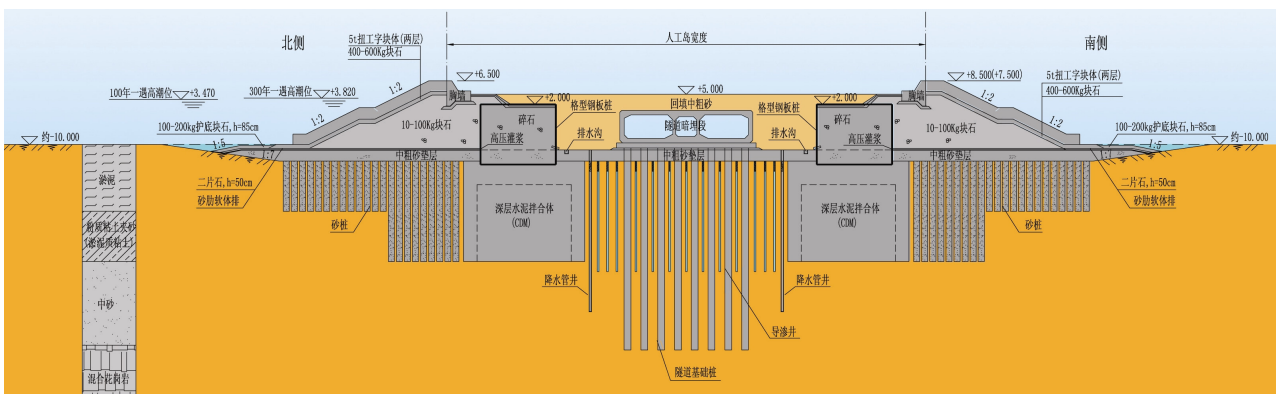

Fig. 12 Typical cross section of artificial island and cut & cover tunnel

Following the general schedule of the project, to avoid delay in tunnel construction, the west artificial island will be constructed in two stages. First a small island will be constructed including a part of the cut & cover tunnel, capable to receive the first immersed tunnel element. Afterwards the larger remaining part the island will be constructed. The east island will be constructed in one phase only since connection with the immersed tunnel will be made by one of the last tunnel elements to be immersed.

3.3 Interface issues tunnel and islands

The area of the artificial islands is very complex from a geotechnical point of view. Large land reclamations in combination with ground improvements (artificial islands) are carried out close to large excavations with ground improvements (trench excavation of the tunnel) but scheduled in different periods of the project program and with a considerable mutual influence. And as explained earlier the ground conditions are not very favourable and subject to time dependent behaviour. The transition area between the immersed tunnel section and artificial islands/cut & cover sections can therefore be considered as very complicated.

Due to the large reclamations in the area of the islands significant settlements can be expected, that will develop with time. For the foundation of the cut & cover tunnel account has to be made for this situation. For the immersed tunnel process, first large dredging operations have to be carried out, followed by the immersion of the tunnel element, back fill next to and on top of the tunnel and a sedimentation process gradually filling up the trench. Due to the dredging operations heave of the sub ground will occur, that will be reduced in time by the subsequent construction operations adding weight again, eventually resulting in settlements. In addition the immersed tunnel will experience only a part of this process, since a part of the heave have already occurred before the tunnel elements are placed.

It can be concluded that complicated 3D geotechnical processes will take place in the sub ground and that they are subject to time effects, related to the construction process. The prediction of these processes is difficult even with state of the art 3D geotechnical FE models. And however the immersed tunnel is capable to deal with differential settlements, the kind of settlement and related differential settlements that are expected to be involved, are considered to be critical. Therefore it was decided to apply robust design solutions in which a smooth transition from the island cut & cover tunnel section to the immersed tunnel section is implemented. This involves:

- A cut & cover tunnel founded on bored piles in / on the deep rock. In this way the tunnel has become independent from the settlements due to the reclamation works;
- The first elements of the immersed sections will be founded on steel piles penetrating the bearing sand layers (above the rock);
- Adjacent immersed tunnel section will be direct founded, however, the soft soils will be treated with settlement reducing or levelling measures such as settlement reduction piles or sand replacement;
- The middle part of the immersed tunnel will be direct founded on the sub ground.

The proposed design solutions are detailed in a way (e.g. pile tunnel connections) that account is made for the construction conditions. Indeed, large part of the works has to be carried out off shore, under which conditions larger construction tolerances have to be accommodated.

For the detailed design phase it has been advised to develop a state of the art 3D FE model in which the transition area is considered, taking into account the various construction stages. This model is supposed to be verified and validated by means of an extensive monitoring program during construction. This will enable the Designer to make more reliable predictions with the progress of the works. These information can be used to confirm design decisions or to make adjustments / optimizations (however, on a limited scale) in both the design and construction (i.e. back analysis).

4. Various items

4.1 Tunnel installations / tunnel safety

4.1.1 General

The length of the sub-sea tunnel, which stands at +6km, poses specific challenges while considering tunnel safety. The depth and location of the tunnel make it not feasible to introduce a ventilation shaft in the middle of the tunnel section requiring development of a concept well beyond current experience.

The HZMB needs an integrated safety concept for the whole of the project, and specifically so for the immersed tunnel. This is a very important prerequisite for the governments of three regions; i.e. to accept, maintain and control the appropriate safety level of the project. Safety is very critical to the tunnel design; safety design concept should be consistent and integral from the very beginning.

As with any project, safety does not only relate to the structural element, such as the tunnel, but also to all other elements within the system, such as vehicles, drivers and the (tunnel) operations, that for example include the emergency response procedures.

For the HZMB project organisation, it is the design of the tunnel (and other structural elements of the Link) that can be influenced, as well as the support systems in the tunnel and the operational procedures. Through the designs, the preconditions for safety will be made.

4.1.2 Outline of safety concept

Obviously, safety is best served by having as few accidents as possible. But since prevention cannot be perfect, adequate response to incidents and accidents is equally important. Upon occurrence of an accident / incident, the drivers and passengers should be able to move away from the accident spot to a safe environment as quickly as possible. Emergency services must have optimal access to the tunnel and accident / incident location to help control or preferably terminate the accident and if required to rescue victims. Traffic must be immediately prevented from entering the tunnel, in order to limit the number of cars and people involved in the accident/incident, and to make sure that the routes of egress and access can be used safely.

Making a tunnel safe involves 6 functional areas, which are related and partially overlapping. They are:

1. Prevention of incidents and accidents
2. Monitoring and detection
3. Control of accidents and direct consequences
4. Self rescue
5. Emergency services' response
6. Traffic management

Only the totality of these 6 areas produces sufficient safety.

This concept has been applied in the development of the Preliminary Design for the HZMB project in general and that for the tunnel in specific.

4.1.3 From an outline to a project specific safety concept

For the HZMB Main Bridge project, following steps have been taken to transform the outline safety concept into a project specific safety concept.

1. As the first step in the development of the project specific safety concept, the objectives for each of the functional areas introduced above, have been defined.
2. As a second step, the basic ideas of how to meet the objectives has been stated in global terms on a system level.

3. From these ideas, the elements involved in meeting the objectives for the functional areas have been identified and the requirements of the elements that are within the project scope specified.
4. Each of these elements has been developed to its specification and during this process the totality of the system has been validated against the initial safety objectives.

Elements outside of the project scope, that are relevant to the functional areas, have been treated as external conditions.

4.1.4 Tunnel safety design elements

The HZMB tunnel specific safety concept has been further transformed into specific elements that will be implemented in the tunnel. These include:

- Jet-fan induced longitudinal tunnel ventilation
- Independent smoke extract ventilation
- Foam-mist fire extinguishing system or sprinkler system
- Escape doors from each of the two traffic tubes to the emergency escape tube at intervals of 90m
- Traffic information system
- Emergency power supply,
- Emergency lighting,
- Emergency escape guiding,
- Accident communication,
- Structural passive fire protection systems, and
- A tunnel monitoring and fire alarm system which receives and processes alarm signals, including automatic alarm signals from special fire detector (linear temperature-sensing detector), and manual alarm buttons located in the tunnel.

After an extensive study a ventilation concept has been selected with longitudinal ventilation in the operational phase (jet fans supported by natural ventilation induced by the piston effect and enhanced by the traffic). In case of a fire a parallel smoke extraction system will be activated using a semi transverse ventilation system including a separate smoke extraction cell (located above the escape cell) combined with an additional system like foam mist fire extinguishing system or a sprinkler system.

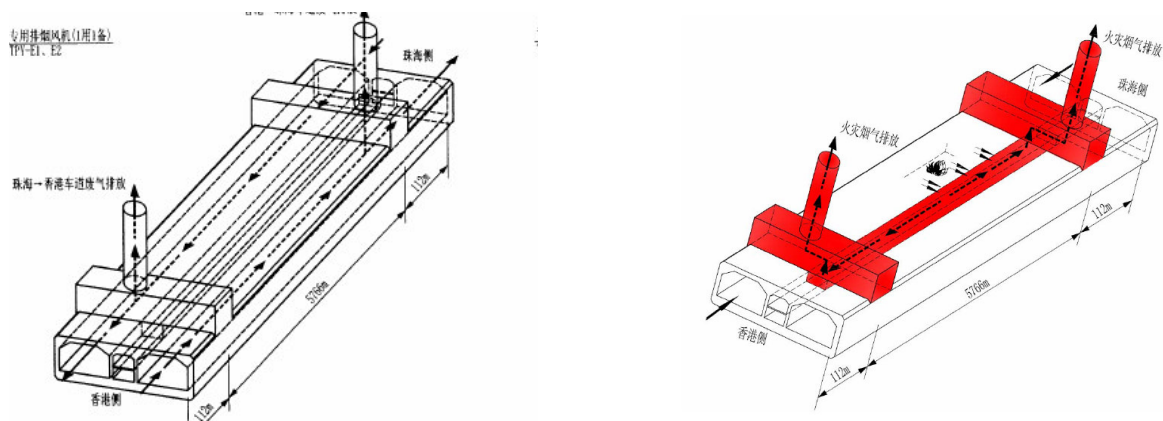

Fig. 13 Ventilation principle in operational phase and in case of a fire

4.2 Durability

4.2.1 The challenges at HZMB Main Bridge project

The design service life of main work of this project is 120 years, which is the first ever specified for such extended period for infrastructure in mainland China. Consequently there are no existing codes or standards available for reference.

Due to the natural condition and engineering structure of the HZMB project, it is located in very

corrosive environment. Potential corrosive factors include: (1) Strong chloride ion corrosion in sea water, (2) high water pressure on the immersed tunnel concrete structure under more than 40m water depth, (3) possible chemical corrosion of sulphate and magnesium salt exist in sea water and sea soil as well as salt crystallization corrosion; (4) carbonation of concrete structure caused by environment and emissions of vehicles.

4.2.2 Design approach

In general, the composition, material characteristics, casting quality, and resulting chloride ion impermeability of the immersed tunnel concrete are very important for guaranteeing the durability. The durability is a very comprehensive requirement which covers various aspects of the whole project. Specially dedicated durability design criterion that include crack control criterion and concrete production technology need to be made for this project. In absence of suitable Chinese Codes & Standards, use has been made of field experience and of Codes from Europe and America.

As part of the HZMB Main Bridge project, special durability related studies have been carried out that used the European DURACRETE and FIB “Model code” as their bases.

In addition, use has been made of the results of the marine durability investigation programme at the South China Zhanjiang Harbour, which is in progress for some 20 years already. At this facility, environmental (corrosion-related) conditions are present that compare well with those at the HZMB.

Using the factual data from the investigation programme, a durability model parameter probability statistic analysis which related to the environment factors, material performances and construction factors has been made. This resulted in a distribution set for several model parameters, such as concrete cover, surface chloride ion concentration, critical concentration and chloride ion diffusion coefficient, and other. It allowed also for the calculation of the partial coefficient of various parameters of durability models at certain targeted reliable index level. Subsequently, it determined the input parameters of a durability design model that has certain target reliability, and finally established a three-element quantitative relation among “Design service life—Cover thickness— Concrete chloride ion diffusion coefficient”.

This durability design method which based on actual environment and material deterioration model is proven to be technically reliable and the derived durability control index by this method for accommodating 120 years actual service life is sufficiently accurate.

Even though the design has produced a configuration that will meet the 120 year life time, it is obvious that the actual life time expectancy will be created during the construction stage. Inadequate concrete compaction, reinforcement designs that hamper the flow of concrete, off-specification concrete mixes, all contribute to sub-design life time expectancy. This has also been recognised by the HZMB Administrative Authority and several actions have been taken to limit the likelihood of occurrence of such sub-quality activities.

4.3 Inspection and maintenance strategy to obtain maximum operation availability

A good tunnel inspection and maintenance strategy (including structure and equipment) is an essential part of the (detailed) design that ensures realization of durability of this project. At the same time, it is also one of the basic three means for guaranteeing the construction goals of this project: “provide excellent service for user”. Therefore the inspection and maintenance strategy of this project should embody the full service lifetime concept to guide the design, and prioritizes to preventive maintenance and takes high efficiency and safe operation as goals.

During the preliminary design phase, the designs have been verified against accessibility, inspectability, maintainability and replaceability. For permanent works, i.e. those that are not replaceable, the design should meet 120-year design life while for others a shorter design life period could be used where the element should be replaced; i.e. depending on the optimal life cycle cost solution.

For the maintenance strategy both conventional and preventive maintenance elements have been considered. An essential element in the development of the strategy is the probabilistic

maintenance or risk driven maintenance assessment.

During the development of the designs a vast amount of monitoring systems has been integrated. These systems not only include those for monitoring of the tunnel control elements that include heat detectors, smoke detectors and other, as well as elements for monitoring the environmental conditions such as wind, temperature, wave climate, etc, monitoring the structural health of the link, i.e. stresses, forces, etc in and between the different elements, and monitoring the operational characteristics of the vast amount of mechanical and electrical installations in the link in general and the tunnel in specific (running hours, output, etc).

5. Finally

The HZMB immersed tunnel design is confronted with new challenges considering its' length, the adverse local conditions (subground, marine environment) and the required design life time of 120 years. New approaches and advanced design and construction techniques have been applied to meet all project requirements. For that reason it can be concluded that this project is stretching the limits of immersed tunnelling. In addition for this project new approaches and philosophies have been developed in terms tunnel safety and tunnel systems / installations and in term of operation and maintenance with regard to a maximum operational availability of the Link.

Currently the construction of the artificial islands and the immersed tunnel is being prepared by the selected Contractor. The works are being carried out following a Design & Construct Contract, which is new on this scale in Chinese Infrastructure projects; another challenge. The preliminary design as described in this paper was used as a reference design for the tender process.

Without any doubt more will be reported about this interesting project in the years to come, when construction is taking place.

References

- [1] HZMB Preliminary design reports , 2010
- [2] HZMB Preliminary design review reports , 2010