

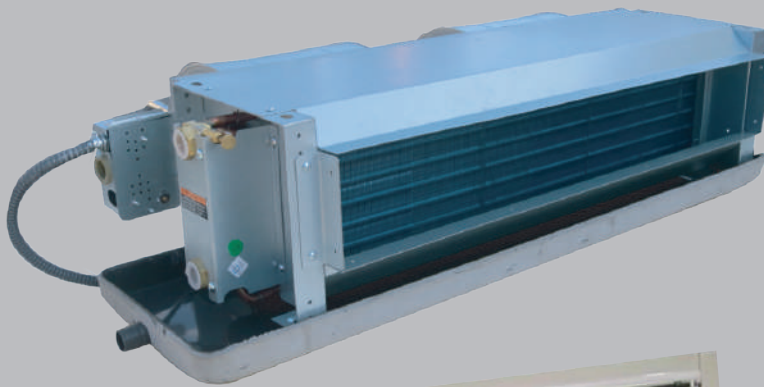

# Horizontal Type

Chilled Water Fan Coil Unit



CA-FCU H-202002

For years, DAIKIN has been providing the society with multiple types of high quality air handling systems and has made remarkable achievements in related fields. Integrating the advanced air conditioner manufacturing technology and process of DAIKIN, DAIKIN fan coil units showcase more compact structure, more convenient installation and maintenance, more efficient performance and lower noises, and have been widely used in public buildings, hospitals, office buildings, hotels, high-end residences, etc.

In this community, DAIKIN is renowned for its complete product series, covering the full range of air-conditioning, purifying and refrigeration equipment. More importantly, DAIKIN boasts the most complete fan coil series and realizes product experience covering units, valves and controls. It is easier to use for customers.



Galaxy SOHO (Beijing)







Palm Jumeirah (Dubai, UAE)

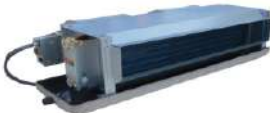

White Swan Hotel (Guangzhou)

## Product Lineup

Airflow range (CMH×100)			0	5	10	15	20	25	30	35	40	45	50	55
	Low ESP standard unit	FWW-VC	340~2380CMH		2220~13000W		DCBL option							
	Mid ESP standard unit	FWW-C	390~3020CMH		2200~16200W									
		FWW-F	360~2960CMH		2622~18000W									
		FWW-H	360~2000CMH		2130~10380W									
	High ESP standard unit	FUW-A	1500~5000CMH		7000~38000W <sup>(2)</sup>									
	District cooling unit	FWW-DA	390~3280CMH		2087~14422W									
	District cooling unit	FWW-AA	340~2380CMH		2125~13744W									
Cooling capacity range (kW)			0	5	10	15	20	~ 40						

Page	Unit model	Coil	Rated ESP	ESP range <sup>(3)</sup>	Appication power supply
Page 4	FWW-VC	2-pipe, 3 rows	12/30/50Pa	0~70Pa	220-240V-/50 Hz (AC) 220-240V-/50[60]Hz (DC)
Page 9	FWW-C	2-pipe, 3 rows	60/80Pa	40~100Pa	220-240V~/50Hz 115V~/60Hz 208-230V~/60Hz
Page 10	FWW-F	2-pipe, 4 rows	60/80Pa	40~100Pa	
Page 11	FWW-H	4-pipe, 3+1 rows	60/80Pa	40~100Pa	
Page 14	FWW-DA	2-pipe, 4 rows	50Pa	40~100Pa	220-240V~/50Hz
Page 18	FWW-AA	2-pipe, 4 rows	0Pa	0Pa	220-240V~/50Hz
Page 21	FUW-A	2-pipe, 4/6 rows	70/100/120/150Pa <sup>(1)</sup>	49~200Pa	220-240V~/50Hz 208-230V~/60Hz

**Remark:** <sup>(1)</sup> means different model have different rated ESP, pls refer to detailed catalogue.

<sup>(2)</sup> cooling capacity is based on return air condition.

<sup>(3)</sup> the ESP range is for H speed of the whole series, different model and speed have differnt ESP range, pls refer to detailed selection software.

## Product Structure

GENERAL

FWW-VC

FWW-C/F/H

FWW-DA

FWW-AA

FUW-A

WIRING

INSTALLATION

### Centrifugal impeller

The centrifugal double-suction fan featuring high-efficiency wide-impeller and forward-curved multi-blade is adopted to implement low speed, large air flow and low noise.



### High-efficiency motor

High efficiency and energy saving, powerful, stable and quiet operation; configuration of the international brand NSK bearing, ensuring efficient, safe and maintenance-free operation.



### Plastic-coated metal hose

The cable protection pipe for the motor uses plastic-coated metal hose; the plastic-coated metal hose is light in weight and well flexible, with outstanding barrier property; The hose is resistant to corrosion, wear and high temperature; it has good insulation property and can better protect safety in use.

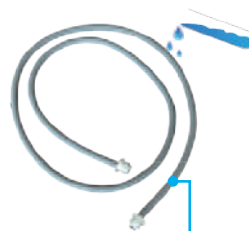

### Smart control (option)

Several types of thermostats options are offered to comply with 2-pipe and 4-pipe system, they are widely used for industrial, commercial and residential buildings, please refer to thermostat's catalog for detailed information.

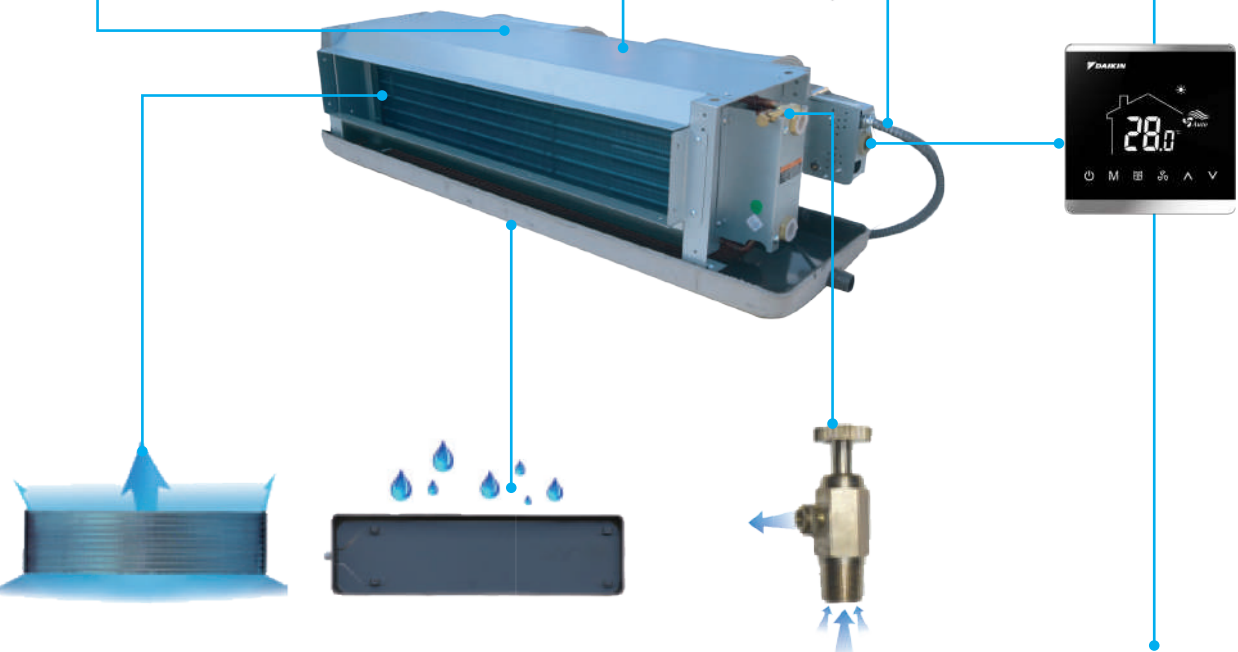

### High-efficiency heat exchanger

Formed using high quality copper tubes and highly efficient hydrophilic aluminum fins through mechanical expansion joint to reduce heat resistance; Quasi counterflow fan coil design enables through heat exchange between air and water to guarantee high efficiency in heat exchange.



### New self-slope drain pan

The self-slope structure design ensures quick drainage of condensate water; with spray on both sides for anti-corrosion, the tray surface is cleaner; the integrated design is adopted to avoid cold bridges.

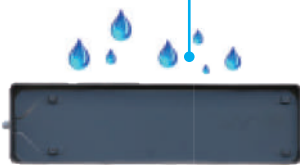

### Manual air vent valve

The unit is configured with manual air vent valve for convenient operation, quicker discharge, and easier installation. The valve is placed at the highest point to guarantee thorough discharging of air in the system and ensure the heat exchange effect.

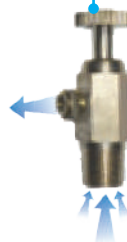

### Brand-new DCBL FCU

FWW-VC series can be equipped with DC motor, featuring higher efficiency and lower power consumption. With a new control board, unit can not only achieve stepless adjustment of the fan speed and water valve, but also can be connected to centralized BMS control system. Meanwhile, field wiring is more simple and delicate wired controller is optional.

# Nomenclature

## Ceiling Concealed Unit FWW-VC

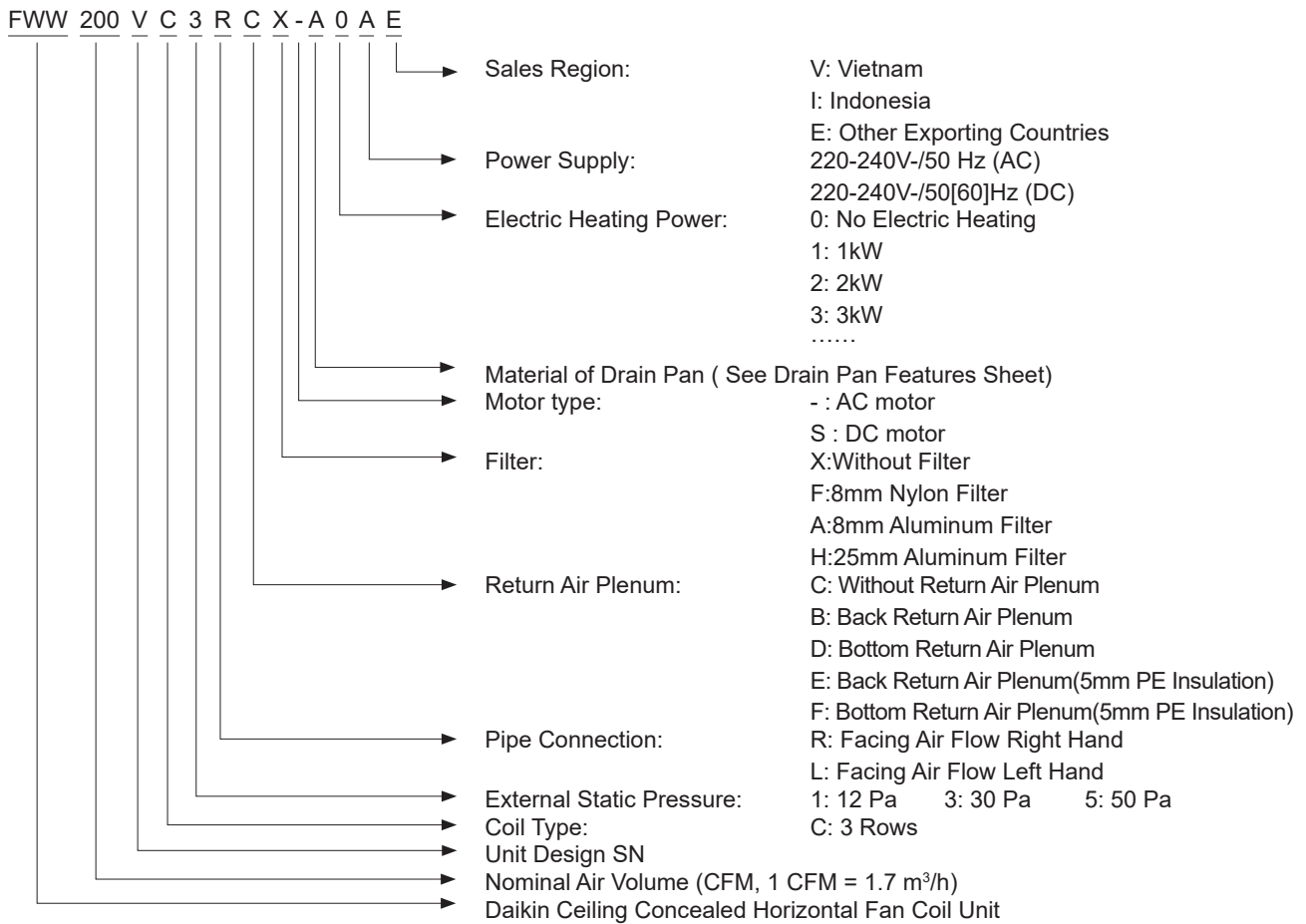

### Drain Pan Features Sheet

Code	Material	Length	Insulation
A	standard	standard	7mm PE
B	standard	+100mm	7mm PE
E	SUS	standard	7mm PE
F	SUS	+100mm	7mm PE
K	standard	standard	6mm class"0" armaflex
P	standard	+100mm	6mm class"0" armaflex
L	SUS	standard	6mm class"0" armaflex
Q	SUS	+100mm	6mm class"0" armaflex

### Electric Heating Power

Option	1.0 kW	2.0kW	3.0kW	4.0kW	5.0kW
FWW200VC	•				
FWW300VC	•				
FWW400VC		•	•		
FWW500VC		•	•		
FWW600VC		•	•		
FWW700VC		•	•		
FWW800VC			•	•	•
FWW1000VC			•	•	•
FWW1200VC			•	•	•
FWW1400VC			•	•	•

**Note:** The power supply of electric heater is 220-240V~/50(60)Hz.

# Technical Specifications

## Ceiling Concealed Unit FWW-VC (AC)

### Standard Unit/2-pipe/3 Rows

		MODEL	FWW200VC	FWW300VC	FWW400VC	FWW500VC	FWW600VC	FWW700VC	FWW800VC	FWW1000VC	FWW1200VC	FWW1400VC	
Performance													
Air flow	High	m <sup>3</sup> /h	340	510	680	850	1020	1170	1360	1700	2040	2380	
		CFM	200	300	400	500	600	688	800	1000	1200	1400	
	Medium	m <sup>3</sup> /h	279	418	530	640	790	900	1115	1350	1600	1952	
		CFM	164	246	312	376	465	529	656	794	941	1148	
	Low	m <sup>3</sup> /h	170	255	340	425	510	585	680	850	1020	1190	
		CFM	100	150	200	250	300	344	400	500	600	700	
External static pressure	Pa	12,30,50											
	in.wg	0.05,0.12,0.20											
Total cooling capacity	W	2220	3300	4260	5050	5820	6600	8200	9300	11190	13000		
	Btu/h	7575	11260	14536	17231	19859	22520	27980	31733	38182	44358		
Sensible cooling capacity	W	1380	2220	2770	3400	4000	4550	5500	6500	7700	9200		
	Btu/h	4709	7575	9452	11601	13649	15525	18767	22179	26273	31392		
Water flow rate	m <sup>3</sup> /h	0.38	0.57	0.73	0.87	1	1.13	1.41	1.59	1.92	2.23		
	USGPM	1.67	2.51	3.21	3.83	4.4	4.98	6.2	7	8.45	9.82		
Water pressure drop	kPa	25	21	30	30	32	35	32	40	35	50		
	in.wg.	0.1	0.1	0.1	0.1	0.1	0.1	0.1	0.2	0.2	0.2		
	Pa	32	43	56	73	93	112	130	147	183	221		
Rated power input (W)	12Pa	High	29	37	49	64	81	100	116	134	159	209	
		Medium	22	28	37	46	66	80	92	114	127	173	
		Low	39	53	70	84	102	118	142	169	206	245	
	30Pa	High	36	45	58	73	93	108	132	160	204	226	
		Medium	27	34	46	55	75	88	105	141	164	193	
		Low	46	62	80	95	114	131	168	200	237	291	
	50Pa	High	39	52	75	86	107	111	146	191	216	280	
		Medium	29	43	68	70	91	99	118	171	195	256	
		Low	0.15	0.2	0.26	0.34	0.43	0.52	0.61	0.7	0.86	1.12	
	Rated running current (A)	12Pa	High	0.14	0.17	0.23	0.3	0.38	0.46	0.54	0.68	0.74	0.96
			Medium	0.11	0.13	0.17	0.22	0.31	0.37	0.43	0.55	0.59	0.8
			Low	0.18	0.24	0.33	0.38	0.49	0.56	0.65	0.8	1	1.19
30Pa		High	0.17	0.21	0.27	0.34	0.43	0.5	0.61	0.77	0.94	1.04	
		Medium	0.13	0.16	0.22	0.26	0.35	0.41	0.49	0.65	0.76	0.89	
		Low	0.21	0.28	0.37	0.44	0.51	0.6	0.77	0.92	1.09	1.45	
50Pa		High	0.18	0.24	0.35	0.4	0.5	0.51	0.68	0.88	1	1.29	
		Medium	0.14	0.2	0.32	0.33	0.42	0.46	0.55	0.79	0.9	1.18	
		Low	35	36	40.5	41	45	45.5	44.5	48	49	51	
Sound pressure level (dB(A))		12Pa	High	30	29.5	36	37	39.5	41	39	44	45	47.5
			Medium	21	25	25	26	30	30	29	33	34	38
			Low	35	36.5	39	41	43.5	44.5	43.5	46.5	47.5	49.5
	30Pa	High	30.5	30.5	32.5	36.5	38	41.5	36.5	41.5	39.5	42.5	
		Medium	19.5	19.5	21.5	26.5	27.5	30	25.5	30.5	31.5	32.5	
		Low	39	40	42	43.5	45.5	45.5	48	49	50.5		
	50Pa	High	33.5	34.5	40	41.5	39	43	40	45	43.5	46	
		Medium	21.5	23	27	31	28	38	27.5	36.5	37.5	38.5	
		Low	Coil										
	Tube material	Copper											
	Filter withdraw	Side withdraw											
	Back return plenum	8mm nylon / aluminum filter	Bottom withdraw										
Bottom return plenum	8mm nylon / aluminum filter	Hydrophilic aluminum 0.11mm											
Fin material	1.6MPa												
Max. working pressure	Rc 3/4 Female thread												
Cooling water pipe Size	R3/4 Male thread												
Condensation water pipe Size	Fan												
Fan	Galvanized steel double stage impeller centrifugal (blade: forward)												
Type	Quantity												
Quantity	1	2	2	2	2	2	3	3	4	4			
Motor	3 Speed Permanent Split Capacitor Motor												
Type	Quantity												
Quantity	1	1	1	1	1	1	2	2	2	2			
Insulation class	IP20/B												
Net weight (kg)	w/o plenum	9.2	12.2	12.6	14.5	15.3	16.7	24.5	25.9	29.4	32.6		
	c/w plenum	12.2	15.6	16.2	18.4	19.9	21.4	30.3	32.2	36.8	40.6		
Gross weight (kg)	w/o plenum	11.3	14.5	15.1	17.2	18.0	19.5	28.2	29.7	33.8	37.6		
	c/w plenum	14.3	17.9	18.7	21.1	22.6	24.2	34.0	36.0	41.2	45.6		

#### NOTES:

- 1) ALL SPECIFICATIONS ARE SUBJECT TO CHANGE BY THE MANUFACTURER WITHOUT PRIOR NOTICE.
- 2) THE AIR FLOW IS DRY AIR FLOW TESTED ON STANDARD AIR CONDITION WITHOUT WATER IN COIL, THE AIR FLOW OF M/L SPEED IS TESTED WITH THE SAME DUCT OF H SPEED.
- 3) THE COOLING CAPACITY ARE BEING TESTED UNDER FOLLOWING CONDITION:  
H SPEED, ENTERING AIR DB/WB: 27°C/19.5°C, WATER INLET 7°C, WATER OUTLET 12°C
- 4) SOUND PRESSURE LEVEL MEASURED IN SEMI-ANECHOIC ROOM WITH BACKGROUND SOUND PRESSARE LEVEL: 11.5DB(A)  
12PA UNIT: ONE METER FRONT AND ONE METER BELOW THE UNIT, WITH RETURN AIR DUCT;  
30/50PA UNIT: ONE METER BELOW THE UNIT, WITH RETURN AND SUPPLY AIR DUCT.
- 5) ALL PERFORMANCE ARE TESTED UNDER 220V~/50HZ AND WITHOUT PLENUM AND FILTER.
- 6) WHEN THE WATER CONNECT DIRECTION IS CHANGED IN FIELD, THE CAPACITY SHOULD BE REDUCED BY 15%.
- 7) PERFORMANCE OF SPECIFIED CONDITION CAN BE CALCULATED BY OUR SOFTWARE.

# Technical Specifications

## Ceiling Concealed Unit FWW-VC (DCBL)



### Standard Unit/2-pipe/3 Rows

		MODEL	FWW200VC	FWW300VC	FWW400VC	FWW500VC	FWW600VC	FWW700VC	FWW800VC	FWW1000VC	FWW1200VC	FWW200VC	
Performance													
Air flow	High	m³/h	340	510	680	850	1020	1170	1360	1700	2040	2380	
		CFM	200	300	400	500	600	688	800	1000	1200	1400	
	Medium	m³/h	279	418	530	640	790	900	1115	1350	1600	1952	
		CFM	164	246	312	376	465	529	656	794	941	1148	
	Low	m³/h	170	255	340	425	510	585	680	850	1020	1190	
		CFM	100	150	200	250	300	344	400	500	600	700	
External static pressure	Pa	12,30,50											
	in.wg	0.05,0.12,0.20											
Total cooling capacity	W	2220	3300	4260	5050	5820	6600	8200	9300	11190	13000		
	Btu/h	7575	11260	14536	17231	19859	22520	27980	31733	38182	44358		
Sensible cooling capacity	W	1380	2220	2770	3400	4000	4550	5500	6500	7700	9200		
	Btu/h	4709	7575	9452	11601	13649	15525	18767	22179	26273	31392		
Water flow rate	m³/h	0.38	0.57	0.73	0.87	1	1.13	1.41	1.59	1.92	2.23		
	USGPM	1.67	2.51	3.21	3.83	4.4	4.98	6.2	7	8.45	9.82		
Water pressure drop	kPa	25	21	30	30	32	35	32	40	35	50		
	in.wg	0.1	0.1	0.1	0.1	0.1	0.1	0.1	0.2	0.2	0.2		
	High	15	19	33	40	54	67	65	88	114	139		
Rated power input (W)	12Pa	Medium	9	11	19	23	30	42	38	57	68	88	
		Low	5	5	8	9	11	15	15	20	23	29	
		High	21	26	40	51	65	73	80	101	140	166	
	30Pa	Medium	12	15	24	29	38	48	49	68	83	103	
		Low	6	7	9	10	12	17	17	23	27	32	
		High	26	36	49	61	80	90	101	125	173	208	
	50Pa	Medium	16	20	29	36	47	57	59	80	99	121	
		Low	7	8	11	12	14	20	19	26	31	37	
		High	0.14	0.17	0.27	0.33	0.42	0.54	0.54	0.81	0.91	1.13	
	Rated running current (A)	12Pa	Medium	0.11	0.12	0.18	0.22	0.27	0.36	0.35	0.5	0.58	0.76
			Low	0.07	0.07	0.1	0.1	0.11	0.15	0.16	0.2	0.24	0.28
			High	0.19	0.23	0.33	0.41	0.52	0.62	0.68	0.94	1.08	1.34
30Pa		Medium	0.13	0.15	0.22	0.26	0.33	0.4	0.42	0.58	0.69	0.88	
		Low	0.08	0.08	0.11	0.11	0.13	0.17	0.18	0.22	0.27	0.31	
		High	0.23	0.3	0.41	0.5	0.64	0.73	0.83	1.11	1.31	1.6	
50Pa		Medium	0.16	0.19	0.26	0.32	0.4	0.47	0.5	0.67	0.8	1.01	
		Low	0.08	0.09	0.12	0.12	0.14	0.19	0.19	0.25	0.3	0.35	
		High	34	35	38.5	42	44	45.5	44.5	47	48.5	50.5	
Sound pressure level (dB(A))		12Pa	Medium	29	30	33	37	38.5	41	40	41.5	44	45.5
			Low	20.5	20.5	23	25.5	27	28	28.5	29	32	34
			High	34	36	38.5	41	42	43	43	45.5	46	48.5
	30Pa	Medium	29.5	29	32.5	35	38	40	36.5	40	39.5	43	
		Low	20	20.5	21.5	24.5	26.5	29	25.5	28.5	28.5	30.5	
		High	38.5	39	41	43	45	45	45	47	48	50.5	
	50Pa	Medium	33.5	33.5	36	37.5	40.5	41	40	42	42	45	
		Low	23.5	23.5	23.5	25.5	29	31.00	27.5	30.50	30	33	
		High	38.5	39	41	43	45	45	45	47	48	50.5	
	Coil												
	Tube material		Copper										
	Filter withdraw												
Back return plenum	8mm nylon / aluminum filter	Side withdraw											
Bottom return plenum	8mm nylon / aluminum filter	Bottom withdraw											
Fin material													
Max. working pressure		1.6MPa											
Cooling water pipe Size		Rc 3/4 Female thread											
Condensation water pipe Size		R3/4 Male thread											
Fan													
Type		Galvanized steel double stage impeller centrifugal (blade: forward)											
Quantity		1	2	2	2	2	2	3	3	4	4		
Motor													
Type		DC brushless motor											
Quantity		1	1	1	1	1	1	2	2	2	2		
Insulation class		IP44/B											
Net weight (kg)	w/o plenum	11.0	13.6	14.0	15.0	15.9	16.5	25.5	26.2	29.5	31.6		
	c/w plenum	14.1	16.9	17.6	19.0	20.5	21.2	31.3	32.4	36.9	39.6		
Gross weight (kg)	w/o plenum	12.9	15.9	16.4	17.6	18.7	19.2	29.1	29.8	33.4	36.0		
	c/w plenum	15.9	19.0	19.8	21.3	23.0	23.6	34.4	35.5	40.2	43.3		

#### NOTES:

- 1) ALL SPECIFICATIONS ARE SUBJECT TO CHANGE BY THE MANUFACTURER WITHOUT PRIOR NOTICE.
- 2) THE AIR FLOW IS DRY AIR FLOW TESTED ON STANDARD AIR CONDITION WITHOUT WATER IN COIL, THE AIR FLOW OF M/L SPEED IS TESTED WITH THE SAME DUCT OF H SPEED.
- 3) THE COOLING CAPACITY ARE BEING TESTED UNDER FOLLOWING CONDITION:  
H SPEED, ENTERING AIR DB/WB: 27°C/19.5°C, WATER INLET 7°C, WATER OUTLET 12°C
- 4) SOUND PRESSURE LEVEL MEASURED IN SEMI-ANECHOIC ROOM WITH BACKGROUND SOUND PRESSARE LEVEL: 11.5DB(A)  
12PA UNIT: ONE METER FRONT AND ONE METER BELOW THE UNIT,WITH RETURN AIR DUCT;  
30/50PA UNIT: ONE METER BELOW THE UNIT, WITH RETURN AND SUPPLY AIR DUCT.
- 5) ALL PERFORMANCE ARE TESTED UNDER 220V~/50HZ AND WITHOUT PLENUM AND FILTER.
- 6) WHEN THE WATER CONNECT DIRECTION IS CHANGED IN FIELD,THE CAPACITY SHOULD BE REDUCED BY 15%.
- 7) PERFORMANCE OF SPECIFIED CONDITION CAN BE CALCULATED BY OUR SOFTWARE.
- 8) \*UC-HMI328AE WIRED CONTROLLER IS OPTIONAL FOR FWW-VC DCBL.

# Dimensions

## Ceiling Concealed Unit FWW-VC

### Without Plenum

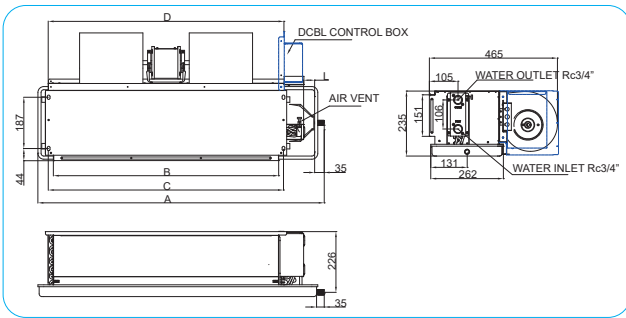

### With Bottom Plenum

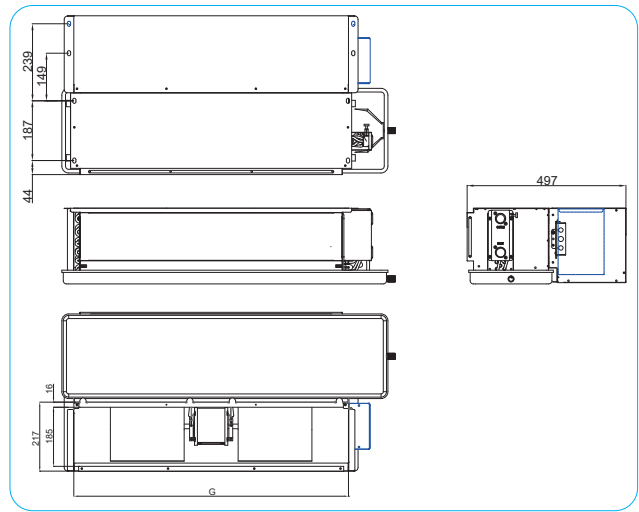

### With Back Plenum

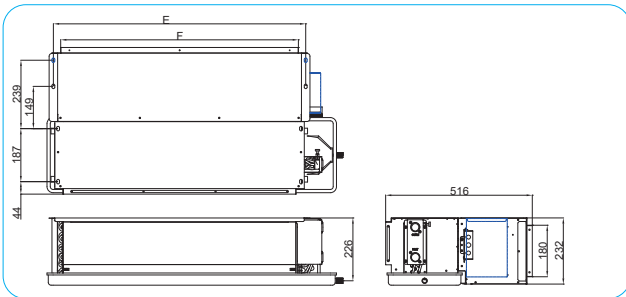

#### Remark:

1. The pipe connection between unit c/w and w/o plenum is the same;
2. Unmarked size of the unit is the same size as unit w/o plenum;
3. The blue line in the figure above is the electric control box of DCBL unit.
4. Above drawing is right hand connection unit.

Model	A		B	C	D	E	F	G	Package dimension (L*H*W) mm				
	Standard drain pan	Extend drain pan							L		Without plenum	With back plenum	With bottom plenum
FWW200VC	625	625+a	402	437	440	472	420	441	40	40+a	641×520×250	641×547×250	641×520×250
FWW300VC	815	815+a	592	627	630	662	610	631	40	40+a	831×520×250	831×547×250	831×520×250
FWW400VC	865	865+a	642	677	680	712	660	681	40	40+a	881×520×250	881×547×250	881×520×250
FWW500VC	945	945+a	722	757	760	792	740	761	40	40+a	961×520×250	961×547×250	961×520×250
FWW600VC	1045	1045+a	822	857	860	892	840	861	40	40+a	1061×520×250	1061×547×250	1061×520×250
FWW700VC	1095	1065+a	872	907	910	942	890	911	40	40+a	1111×520×250	1111×547×250	1111×520×250
FWW800VC	1425	1425+a	1202	1237	1240	1272	1220	1241	40	40+a	1441×520×250	1441×547×250	1441×520×250
FWW1000VC	1475	1475+a	1252	1287	1290	1322	1270	1291	40	40+a	1491×520×250	1491×547×250	1491×520×250
FWW1200VC	1675	1675+a	1452	1487	1490	1522	1470	1491	40	40+a	1691×520×250	1691×547×250	1691×520×250
FWW1400VC	1825	1825+a	1602	1637	1640	1672	1620	1641	40	40+a	1841×520×250	1841×547×250	1841×520×250

- Remark: 1. In the sheet, "a" could be 100/200;  
 2. The size of the outlet of condensate drain is R3/4;  
 3. The hosting hole size is 10x16mm.  
 4. Above package dimension is the dimension of unit c/w stanard drain pan.

## Exploded-View & Part List

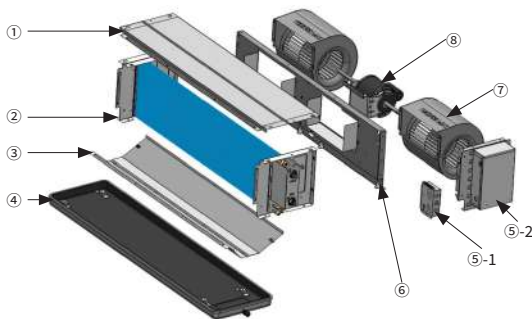

Item	Description
1	Top plate
2	Heat exchanger
3	Deflector
4	Drain pan
5	Control box 5-1: AC FCU 5-2: DCBL FCU
6	Motor plate
7	Fan
8	Motor

Note: it is FWW700VC unit in the figure, without return air box and filter.

## Wired Controller (option)

### Features

- SH-H-M-L-SL-Auto speed
- Mode/Fan speed/Temperature adjustment
- Sensor error alarm / Filter clean reminder
- Intelligent body approaches awakening
- Schedule management
- ESP adjustment



### Specifications\*

Voltage range	12 VDC ± 10%
Working condition	-20°C~55°C, 10%~90%RH (no dew)
Storage condition	-30°C~65°C, 10%~90%RH (no dew)
Temperature display precision	0.5°C
Maximum power consumption	≤2W
Dimensions	88 mm × 88 mm × 14.5 mm

### Purchase code

UC-HMI328AE

Remark: UC-HMI328AE should be equipped with CR1220 battery but does not come with it, the battery needs to be provided by the customer. Please refer to IOM for detailed specification instruction and setting method.

# Nomenclature

## Ceiling Concealed Unit FWW-C/F/H

### FWW-C/H/F Series without Electric Heater

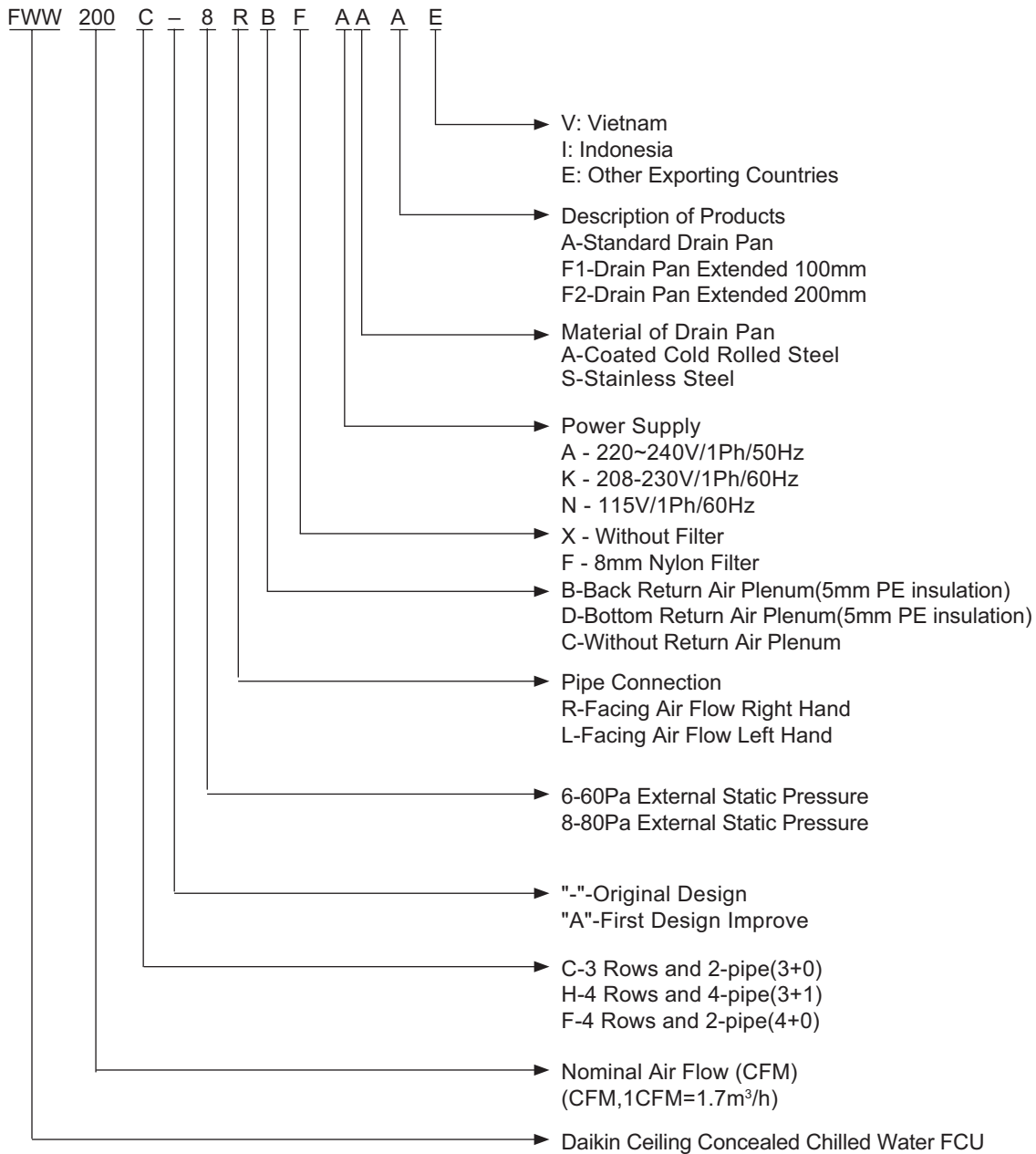



# Nomenclature

## FWW-C Series with Electric Heater

FWW 2 CD 10 - 8 R B F A A A E

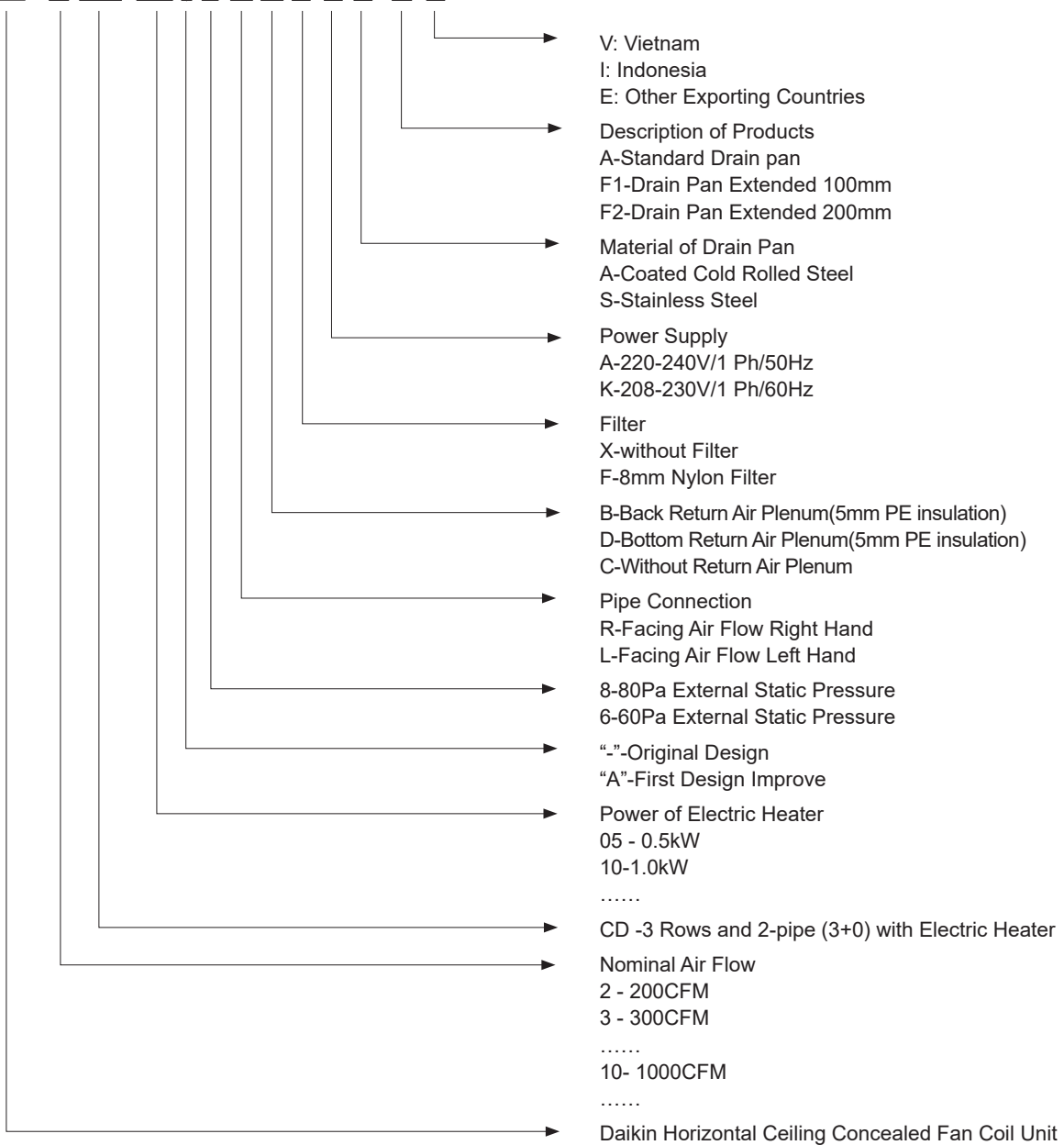

## Electric Heater Power

Option	1.0 kW	2.0kW	3.0kW	4.0kW	5.0kW	6.0kW
FWW2CD	•					
FWW3CD	•	•				
FWW4CD	•	•				
FWW6CD		•	•			
FWW8CD		•	•	•		
FWW10CD			•	•		
FWW12CD			•	•	•	•
FWW14CD				•	•	•
FWW16CD				•	•	•
FWW18CD				•	•	•

**Note:** The power supply of electric heater is 220-240V~/50(60)Hz.

# Technical Specifications

## Ceiling Concealed Unit FWW-C

### Standard Unit/2-pipe/3 Rows

		MODEL	FWW200C	FWW300C	FWW400C	FWW600C	FWW800C	FWW1000C	FWW1200C	FWW1400C	FWW1600C	FWW1800C
Performance												
Air flow	High	m <sup>3</sup> /h	390	530	760	1040	1420	1620	2040	2350	2700	3020
		CFM	229	312	447	612	835	953	1200	1382	1588	1776
	Medium	m <sup>3</sup> /h	260	370	490	780	1090	1140	1500	2050	2430	2780
		CFM	153	218	288	459	641	671	882	1206	1429	1635
	Low	m <sup>3</sup> /h	190	240	340	500	740	830	1020	1550	1830	2180
		CFM	112	141	200	294	435	488	600	912	1076	1282
External static pressure		Pa	60/80									
		in.wg	0.24/0.32									
Total cooling capacity		W	2200	3200	4390	6160	7810	8830	10700	12500	14500	16200
		Btu/h	7507	10919	14979	21019	26649	30129	36510	42651	49476	55277
Sensible cooling capacity		W	1738	2359	3242	4401	6040	6409	7763	9100	10700	11850
		Btu/h	5930	8049	11062	15017	20609	21868	26488	31050	36509	40433
Water flow rate		m <sup>3</sup> /h	0.38	0.55	0.75	1.06	1.34	1.51	1.83	2.14	2.49	2.78
		USGPM	1.67	2.42	3.3	4.67	5.9	6.65	8.06	9.42	10.96	12.24
Water pressure drop		kPa	15	12	22	38	18	21	33	35	37	34
		in.wg.	58	48	86	153	74	84	131	140	148	136
		High	42	44	45	47	49	50	51	51.5	53	53.5
Sound pressure level (dB(A))	60Pa	Medium	38	39	41	43	46	47	48	50	51.5	52
		Low	36	36	38	40	43	44	41	46.5	47.5	49.5
		High	43.9	45	47.4	49.4	49.7	51.6	52.6	52	53.5	54
	80Pa	Medium	42.3	42.2	43	47.4	48	49	50	50.5	52	52.5
		Low	39	39.8	41	42	46	46	47	47	48	50
		High	47.4	48	49	50	51	52	53	54	55	56
Electrical Data												
220-240V~/50Hz	Rated power Input-60Pa (W)	High	47	69	83	149	205	219	271	390	510	564
		Medium	39	58	63	123	185	183	235	354	408	511
		Low	35	47	53	105	163	159	209	249	288	387
	Rated running current-60Pa (A)	High	0.21	0.31	0.38	0.68	0.93	1	1.23	1.78	2.43	2.57
		Medium	0.19	0.29	0.3	0.57	0.84	0.86	1.07	1.61	1.96	2.33
		Low	0.17	0.26	0.26	0.49	0.74	0.74	0.95	1.13	1.38	1.77
	Rated power Input-80Pa (W)	High	51	73	97	157	215	237	281	406	519	590
		Medium	45	60	71	125	193	189	237	368	417	522
		Low	37	51	57	113	175	173	221	257	297	402
	Rated running current-80Pa (A)	High	0.23	0.33	0.44	0.71	0.98	1.08	1.28	1.86	2.57	2.7
		Medium	0.21	0.3	0.33	0.57	0.88	0.87	1.09	1.69	2.09	2.38
		Low	0.18	0.27	0.28	0.52	0.8	0.8	1.01	1.17	1.47	1.84
208-230V~/60Hz	Rated power Input-60Pa (W)	High	75	97	125	175	248	270	335	334	656	835
		Medium	70	89	108	156	218	242	304	288	522	729
		Low	60	75	97	129	182	201	242	214	352	530
	Rated running current-60Pa (A)	High	0.36	0.47	0.6	0.84	1.19	1.3	1.61	1.59	3.43	3.85
		Medium	0.33	0.44	0.55	0.75	1.05	1.16	1.46	1.34	2.68	3.34
		Low	0.29	0.39	0.49	0.63	0.88	0.98	1.2	0.97	1.77	2.41
115V~/60Hz	Rated power Input-80Pa (W)	High	72	107	125	187	253	283	353	-	-	-
		Medium	53	69	93	135	209	211	265	-	-	-
		Low	45	57	81	123	193	187	247	-	-	-
	Rated running current-80Pa (A)	High	0.63	0.93	1.09	1.63	2.2	2.46	3.07	-	-	-
		Medium	0.49	0.67	0.86	1.2	1.84	1.85	2.33	-	-	-
		Low	0.43	0.57	0.76	1.1	1.69	1.7	2.2	-	-	-
Coil												
Tube material		Copper										
Fin material		Hydrophilic aluminum 0.11mm										
Filter withdraw												
Back return plenum	8mm nylon filter	Front withdraw							Side/bottom withdraw			
Bottom return plenum	8 mm nylon filter	Side withdraw										
Max. working pressure		1.6MPa										
Cooling water pipe Size		Rc 3/4 Female thread							Rc 1 Female thread			
Condensation water pipe size		R3/4 Male thread										
Fan												
Type		Galvanized steel double stage impeller centrifugal (blade: forward)										
Quantity		1	2	3	4	2						
Motor												
Type		3 speed permanent split capacitor motor										
Quantity		1	1	2	2	1						
Insulation class		IP20/B										

#### NOTES:

- 1) ALL SPECIFICATIONS ARE SUBJECT TO CHANGE BY THE MANUFACTURER WITHOUT PRIOR NOTICE.
- 2) THE AIR FLOW IS DRY AIR FLOW TESTED ON STANDARD AIR CONDITION WITHOUT WATER IN COIL.
- 3) THE COOLING CAPACITY ARE BEING TESTED UNDER FOLLOWING CONDITION:  
H SPEED, ENTERING AIR DB/WB: 27°C/19.5°C, WATER INLET 7°C, WATER OUTLET 12°C
- 4) SOUND PRESSURE MEASURED AT 1M IN FRONT OF THE UNIT AND 1M BELOW THE VERTICAL CENTER LINE OF THE UNIT, AND TESTED IN SEMI-ANECHOIC ROOM, WITH BACKGROUND SOUND PRESSURE LEVEL: 11.5DB (A).
- 5) ALL PERFORMANCE ARE TESTED UNDER 220V~/50HZ AND WITHOUT PLENUM AND FILTER.
- 6) WHEN THE WATER CONNECT DIRECTION IS CHANGED IN FIELD,THE CAPACITY SHOULD BE REDUCED BY 15%.
- 7) PERFORMANCE OF SPECIFIED CONDITION CAN BE CALCULATED BY OUR SOFTWARE.

# Technical Specifications

## Ceiling Concealed Unit FWW-F

### Standard Unit/2-pipe/4 Rows

		MODEL	FWW200F	FWW300F	FWW400F	FWW600F	FWW800F	FWW1000F	FWW1200F	FWW1400F	FWW1600F	FWW1800F
Performance												
Air flow	High	m <sup>3</sup> /h	360	510	750	1010	1380	1570	2000	2270	2650	2960
		CFM	212	300	441	594	812	924	1176	1335	1559	1741
	Medium	m <sup>3</sup> /h	250	350	470	770	1070	1100	1470	1980	2340	2700
		CFM	147	206	276	453	629	653	865	1165	1376	1588
	Low	m <sup>3</sup> /h	180	230	330	490	720	820	1010	1500	1800	2150
		CFM	106	135	194	288	424	482	594	882	1059	1265
External static pressure		Pa	60/80									
		in.wg	0.24/0.32									
Total cooling capacity		W	2622	3418	5277	7185	8691	10261	12791	13800	16200	18000
		Btu/h	8948	11661	18007	24517	29653	35013	43644	47086	55274	61416
Sensible cooling capacity		W	1783	2406	3536	5047	6365	7297	9382	9600	11460	12700
		Btu/h	6085	8210	12066	17222	21719	24899	32011	32756	39103	43334
Water flow rate		m <sup>3</sup> /h	0.45	0.59	0.9	1.23	1.49	1.76	2.19	2.37	2.78	3.08
		USGPM	1.98	2.6	3.96	5.42	6.56	7.75	9.64	10.44	12.24	13.56
Water pressure drop		kPa	2	6	13	27	9	12	20	35	40	38
		in.wg.	8	24	52	108	36	48	80	140	160	152
Sound pressure level (dB(A))		60Pa	High	42	44	45	47	49	50	51	53	53.5
			Medium	38	39	41	43	46	47	48	51	51.5
			Low	36	36	38	40	43	44	41	48	49
		80Pa	High	43.9	45	47.4	49.4	49.7	51.6	52.6	53	54
			Medium	42.3	42.2	43	47.4	48	49	50	51.5	52.5
			Low	39	39.8	41	42	46	46	47	49	49.5
Electrical Data												
220-240V~/50Hz	Rated power Input-60Pa (W)	High	47	69	83	149	205	219	271	384	498	553
		Medium	39	58	63	123	185	183	235	348	403	501
		Low	35	47	53	105	163	159	209	246	286	382
	Rated running current-60Pa (A)	High	0.21	0.31	0.38	0.68	0.93	1	1.23	1.74	2.42	2.52
		Medium	0.19	0.29	0.3	0.57	0.84	0.86	1.07	1.58	1.94	2.28
		Low	0.17	0.26	0.26	0.49	0.74	0.74	0.95	1.12	1.38	1.74
	Rated power Input-80Pa (W)	High	51	73	97	157	215	237	281	398	510	574
		Medium	45	60	71	125	193	189	237	362	411	508
		Low	37	51	57	113	175	173	221	254	291	394
	Rated running current-80Pa (A)	High	0.23	0.33	0.44	0.71	0.98	1.08	1.28	1.83	2.55	2.62
		Medium	0.21	0.3	0.33	0.57	0.88	0.87	1.09	1.66	2.08	2.32
		Low	0.18	0.27	0.28	0.52	0.8	0.8	1.01	1.16	1.47	1.8
208-230V~/60Hz	Rated power Input-60Pa (W)	High	75	97	125	175	248	270	335	321	653	812
		Medium	70	89	108	156	218	242	304	277	521	709
		Low	60	75	97	129	182	201	242	208	351	519
	Rated running current-60Pa (A)	High	0.36	0.47	0.6	0.84	1.19	1.3	1.61	1.54	3.4	3.74
		Medium	0.33	0.44	0.55	0.75	1.05	1.16	1.46	1.3	2.67	3.26
		Low	0.29	0.39	0.49	0.63	0.88	0.98	1.2	0.95	1.76	2.36
115V~/60Hz	Rated power Input-80Pa (W)	High	72	107	125	187	253	283	353	-	-	-
		Medium	53	69	93	135	209	211	265	-	-	-
		Low	45	57	81	123	193	187	247	-	-	-
	Rated running current-80Pa (A)	High	0.63	0.93	1.09	1.63	2.2	2.46	3.07	-	-	-
		Medium	0.49	0.67	0.86	1.2	1.84	1.85	2.33	-	-	-
		Low	0.43	0.57	0.76	1.1	1.69	1.7	2.2	-	-	-
Coil												
Tube material		Copper										
Fin material		Hydrophilic aluminum 0.11mm										
Filter withdraw												
Back return plenum	8mm nylon filter	Front withdraw							Side/bottom withdraw			
Bottom return plenum	8 mm nylon filter	Side withdraw										
Max. working pressure		1.6MPa										
Cooling water pipe Size		Rc 3/4 Female thread							Rc 1 Female thread			
Condensation water pipe size		R3/4 Male thread										
Fan												
Type		Galvanized steel double stage impeller centrifugal (blade: forward)										
Quantity		1	2	3	4	2						
Motor												
Type		3 speed permanent split capacitor motor										
Quantity		1	1	2	2	1						
Insulation class		IP20/B							IP20/F			

#### NOTES:

- 1) ALL SPECIFICATIONS ARE SUBJECT TO CHANGE BY THE MANUFACTURER WITHOUT PRIOR NOTICE.
- 2) THE AIR FLOW IS DRY AIR FLOW TESTED ON STANDARD AIR CONDITION WITHOUT WATER IN COIL.
- 3) THE COOLING CAPACITY ARE BEING TESTED UNDER FOLLOWING CONDITION:  
H SPEED, ENTERING AIR DB/WB: 27°C/19.5°C, WATER INLET 7°C, WATER OUTLET 12°C
- 4) SOUND PRESSURE MEASURED AT 1M IN FRONT OF THE UNIT AND 1M BELOW THE VERTICAL CENTER LINE OF THE UNIT, AND TESTED IN SEMI-ANECHOIC ROOM, WITH BACKGROUND SOUND PRESSURE LEVEL: 11.5DB (A).
- 5) ALL PERFORMANCE ARE TESTED UNDER 220V~/50HZ AND WITHOUT PLENUM AND FILTER.
- 6) WHEN THE WATER CONNECT DIRECTION IS CHANGED IN FIELD,THE CAPACITY SHOULD BE REDUCED BY 15%.
- 7) PERFORMANCE OF SPECIFIED CONDITION CAN BE CALCULATED BY OUR SOFTWARE.

# Technical Specifications

## Ceiling Concealed Unit FWW-H

### Standard Unit/4-pipe/3+1 Rows

		MODEL	FWW200H	FWW300H	FWW400H	FWW600H	FWW800H	FWW1000H	FWW1200H
Performance									
Air flow	High	m³/h	360	510	750	1010	1380	1570	2000
		CFM	212	300	441	594	812	924	1176
	Medium	m³/h	250	350	470	770	1070	1100	1470
		CFM	147	206	276	453	629	653	865
	Low	m³/h	180	230	330	490	720	820	1010
		CFM	106	135	194	288	424	482	594
External static pressure		Pa	60/80						
		in.wg	0.24/0.32						
Total cooling capacity		W	2130	3100	4260	5980	7580	8570	10380
		Btu/h	7268	10578	14536	20405	25864	29242	35418
Sensible cooling capacity		W	1638	2285	3146	4272	5862	6220	7531
		Btu/h	5589	7798	10735	14578	20002	21224	25696
Cooling water flow rate		m³/h	0.36	0.53	0.73	1.03	1.3	1.47	1.78
		USGPM	1.6	2.33	3.21	4.54	5.72	6.47	7.84
Cooling water pressure drop		kPa	13	11	21	36	17	20	31
		in.wg.	52	44	84	144	68	80	124
Heating capacity		W	1350	2280	3210	4290	5120	6940	8490
		Btu/h	4606	7780	10953	14638	17470	23680	28969
Heating water flow rate		m³/h	0.2	0.2	0.2	0.2	0.2	0.5	0.5
		USGPM	1.1	1.1	1.1	1.1	1.1	2.2	2.2
Sound pressure level (dB(A))	60Pa	High	42	44	45	47	49	50	51
		Medium	38	39	41	43	46	47	48
		Low	36	36	38	40	43	44	41
	80Pa	High	43.9	45	47.4	49.4	49.7	51.6	52.6
		Medium	42.3	42.2	43	47.4	48	49	50
		Low	39	39.8	41	42	46	46	47
Electrical Data									
220-240V~/50Hz	Rated power Input-60Pa (W)	High	47	69	83	149	205	219	271
		Medium	39	58	63	123	185	183	235
		Low	35	47	53	105	163	159	209
	Rated running current-60Pa (A)	High	0.21	0.31	0.38	0.68	0.93	1	1.23
		Medium	0.19	0.29	0.3	0.57	0.84	0.86	1.07
		Low	0.17	0.26	0.26	0.49	0.74	0.74	0.95
	Rated power Input-80Pa (W)	High	51	73	97	157	215	237	281
		Medium	45	60	71	125	193	189	237
		Low	37	51	57	113	175	173	221
	Rated running current-80Pa (A)	High	0.23	0.33	0.44	0.71	0.98	1.08	1.28
		Medium	0.21	0.3	0.33	0.57	0.88	0.87	1.09
		Low	0.18	0.27	0.28	0.52	0.8	0.8	1.01
208-230V~/60Hz	Rated power Input-80Pa (W)	High	75	97	125	175	248	270	335
		Medium	70	89	108	156	218	242	304
		Low	60	75	97	129	182	201	242
	Rated running current-80Pa (A)	High	0.36	0.47	0.6	0.84	1.19	1.3	1.61
		Medium	0.33	0.44	0.55	0.75	1.05	1.16	1.46
		Low	0.29	0.39	0.49	0.63	0.88	0.98	1.2
115V~/60Hz	Rated power Input-80Pa (W)	High	72	107	125	187	253	283	353
		Medium	53	69	93	135	209	211	265
		Low	45	57	81	123	193	187	247
	Rated running current-80Pa (A)	High	0.63	0.93	1.09	1.63	2.2	2.46	3.07
		Medium	0.49	0.67	0.86	1.2	1.84	1.85	2.33
		Low	0.43	0.57	0.76	1.1	1.69	1.7	2.2
Coil									
Tube material		Copper							
Fin material		Hydrophilic aluminum 0.11mm							
Filter withdraw									
Back return plenum	8mm nylon filter	Front withdraw							
Bottom return plenum	8 mm nylon filter	Side withdraw							
Max. working pressure		1.6MPa							
Cooling water pipe size		Rc 3/4 Female thread							
Condensation water pipe size		R3/4 Male thread							
Fan									
Type		Galvanized steel double stage impeller forward centrifugal							
Quantity		1	2	3	4				
Motor									
Type		3 speed permanent split capacitor motor							
Quantity		1	1	2	2				
Insulation class		IP20/B							

#### NOTES:

- 1) ALL SPECIFICATIONS ARE SUBJECT TO CHANGE BY THE MANUFACTURER WITHOUT PRIOR NOTICE.
- 2) THE AIR FLOW IS DRY AIR FLOW TESTED ON STANDARD AIR CONDITION WITHOUT WATER IN COIL.
- 3) THE COOLING CAPACITY ARE BEING TESTED UNDER FOLLOWING CONDITION:  
H SPEED, ENTERING AIR DB/WB: 27°C/19.5°C, WATER INLET 7°C, WATER OUTLET 12°C  
HEATING: H SPEED, ENTERING AIR DB: 21°C, WATER INLET 60°C, WATER OUTLET 50°C
- 4) SOUND PRESSURE MEASURED AT 1M IN FRONT OF THE UNIT AND 1M BELOW THE VERTICAL CENTER LINE OF THE UNIT, AND TESTED IN SEMI-ANECHOIC ROOM, WITH BACKGROUND SOUND PRESSURE LEVEL: 11.5DB (A).
- 5) ALL PERFORMANCE ARE TESTED UNDER 220V~/50HZ AND WITHOUT PLENUM AND FILTER.
- 6) WHEN THE WATER CONNECT DIRECTION IS CHANGED IN FIELD,THE CAPACITY SHOULD BE REDUCED BY 15%.
- 7) PERFORMANCE OF SPECIFIED CONDITION CAN BE CALCULATED BY OUR SOFTWARE.

# Dimensions

## Ceiling Concealed Unit FWW-C/F/H

### FWW200-1200C/F/H

#### Without Plenum

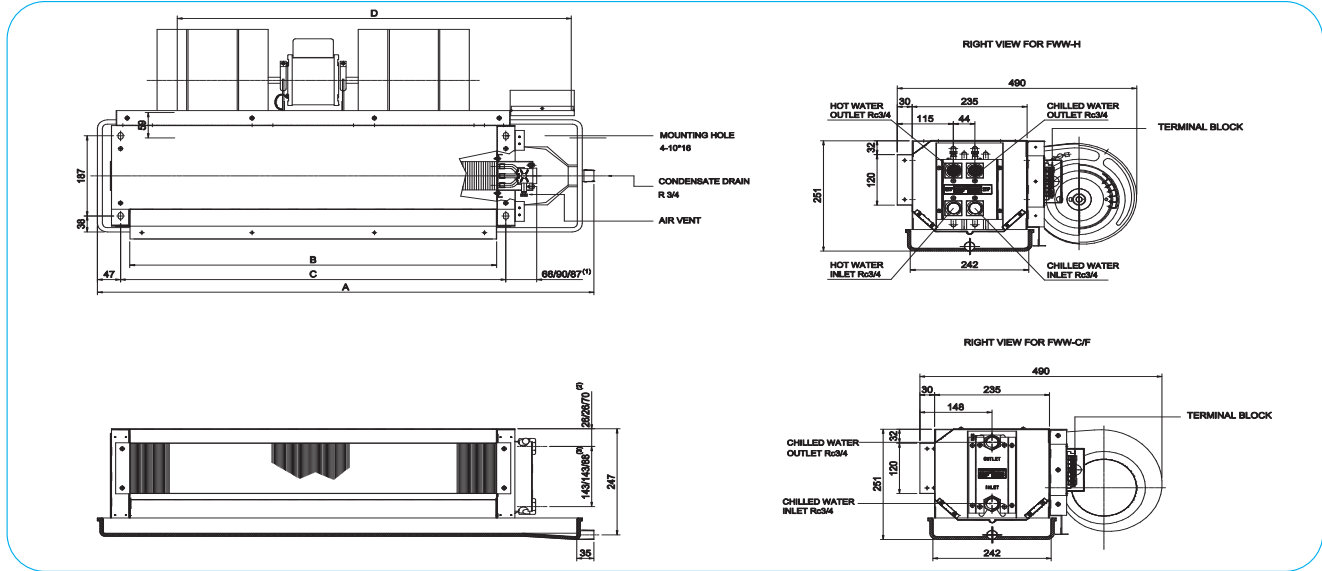

Remark: the three sizes of the dimensions marked (1) (2) (3) are for C/F/H series respectively.

#### With Plenum

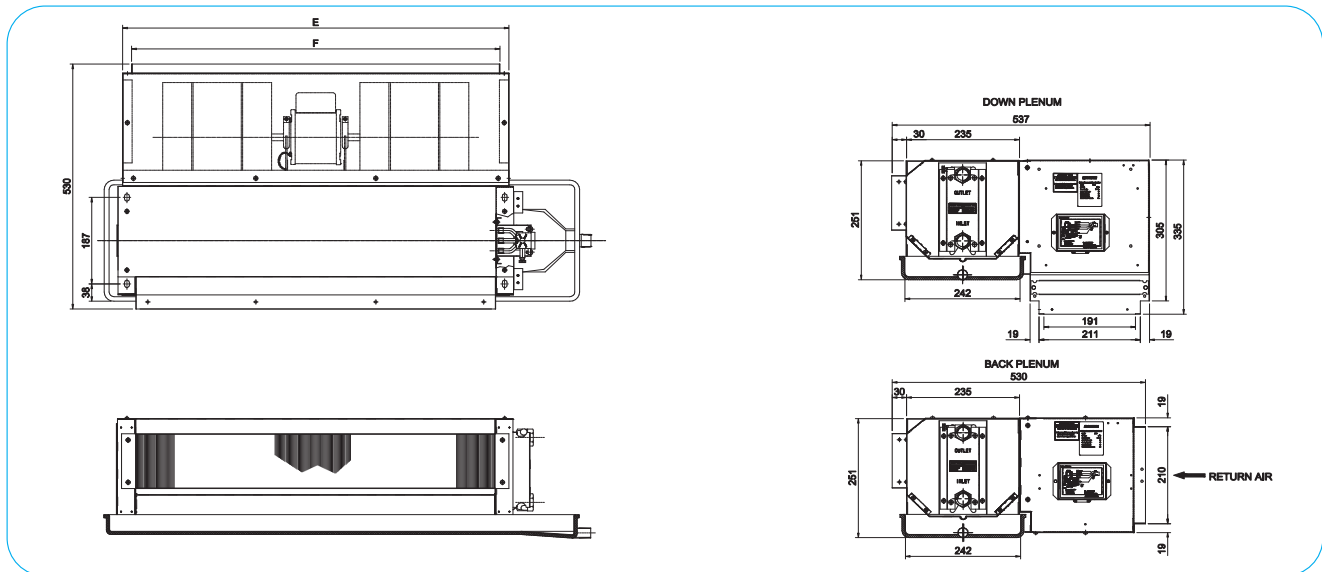

Model	A			B	C	D	E	F	Package dimension (L*W*H)		
	Standard drain pan	100mm extend drain pan	200mm extend drain pan						Without plenum	With back plenum	With bottom plenum
FWW200	714	814	914	448	487	505	507	467	739×535×265	739×559×275	739×565×352
FWW300	884	984	1084	618	657	675	677	637	909×535×265	909×559×275	909×565×352
FWW400	1014	1114	1214	748	787	805	807	767	1039×535×265	1039×559×275	1039×565×352
FWW600	1214	1314	1414	948	987	1005	1007	967	1239×535×265	1239×559×275	1239×565×352
FWW800	1464	1564	1664	1198	1237	1255	1257	1217	1489×535×265	1489×559×275	1489×565×352
FWW1000	1564	1664	1764	1298	1337	1355	1357	1317	1589×535×265	1589×559×275	1589×565×352
FWW1200	1824	1924	2024	1558	1597	1615	1617	1577	1849×535×265	1849×559×275	1849×565×352

Model	Net weight						Unit gross weight					
	3 rows		4 rows		3+1 rows		3 rows		4 rows		3+1 rows	
	Without plenum	With plenum	Without plenum	With plenum	Without plenum	With plenum	Without plenum	With plenum	Without plenum	With plenum	Without plenum	With plenum
FWW200	19	20	20	22	20	22	21.7	22.7	22.7	24.7	22.7	24.7
FWW300	20	24	24	27	24	27	24.8	28.8	26.8	29.8	26.8	29.8
FWW400	26	28	28	31	28	31	29.5	31.5	31.5	34.5	31.5	34.5
FWW600	30	33	32	36	32	36	33.6	36.6	35.6	39.6	35.6	39.6
FWW800	41	44	44	48	44	48	44	47	47	51	47	51
FWW1000	44	47	47	52	47	52	47.8	50.8	50.8	55.8	50.8	55.8
FWW1200	46	50	49	56	49	56	51.2	55.2	54.2	61.2	54.2	61.2

# Dimensions

## Ceiling Concealed Unit FWW-C/F/H

### FWW1400-1800C/F

#### Without Plenum

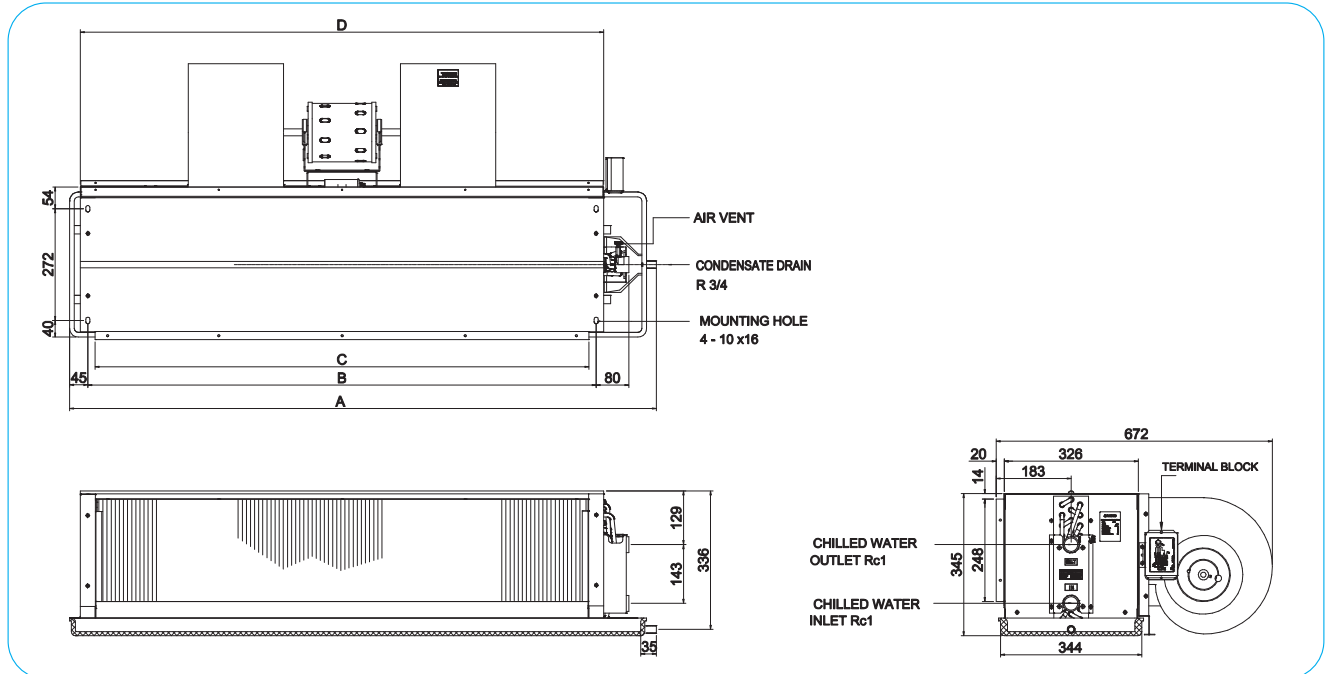

#### With Plenum

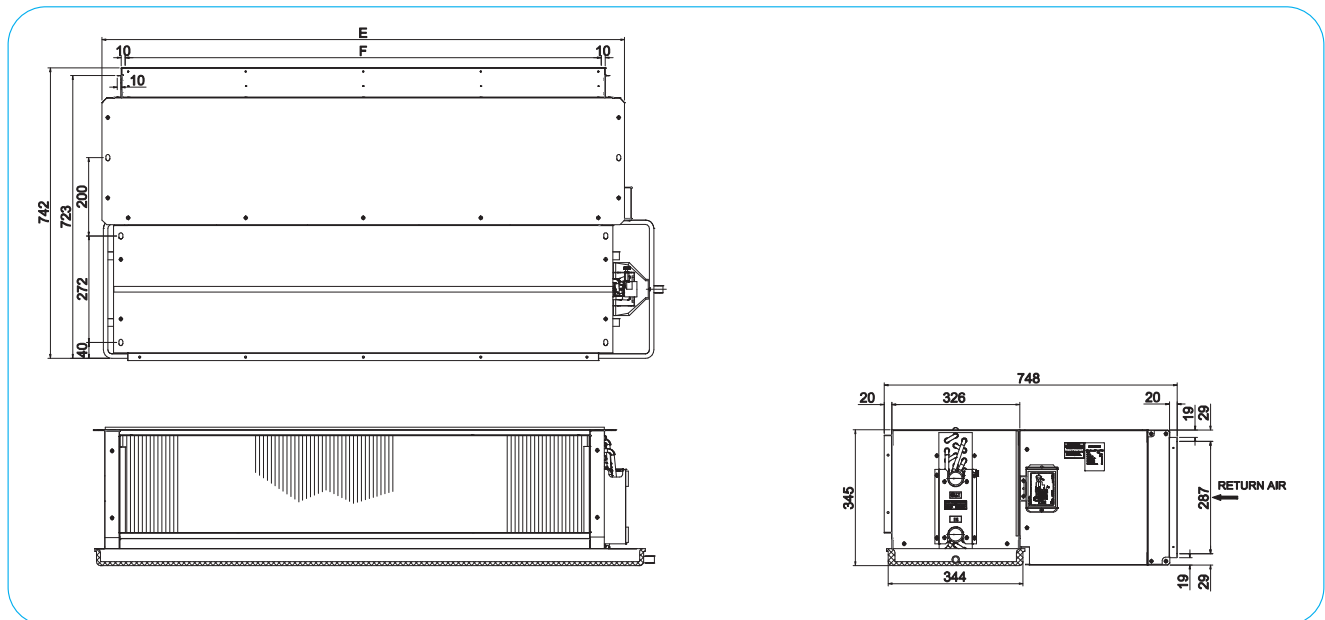

Model	A			B	C	D	E	F	Package dimension (L*H*W)	
	Standard drain pan	100mm extend drain pan	200mm extend drain pan						Without plenum	With back plenum
FWW1400	1195	1295	1395	985	950	1125	1084	965	1220×710×365	1220×775×365
FWW1600	1295	1395	1495	1085	1050	1225	1184	1065	1320×710×365	1320×775×365
FWW1800	1445	1545	1645	1235	1200	1375	1334	1215	1470×710×365	1470×775×365

Model	Net weight				Unit gross weight			
	3 rows		4 rows		3 rows		4 rows	
	Without plenum	With plenum	Without plenum	With plenum	Without plenum	With plenum	Without plenum	With plenum
FWW1400	41.5	51	43.5	53.5	46	54.5	48	57
FWW1600	45	55.5	47.5	58	49.5	58.5	52	61
FWW1800	49	59	51.5	61	54	62.5	56	64.5

# Nomenclature

## Ceiling Concealed Unit for District Cooling FWW-DA

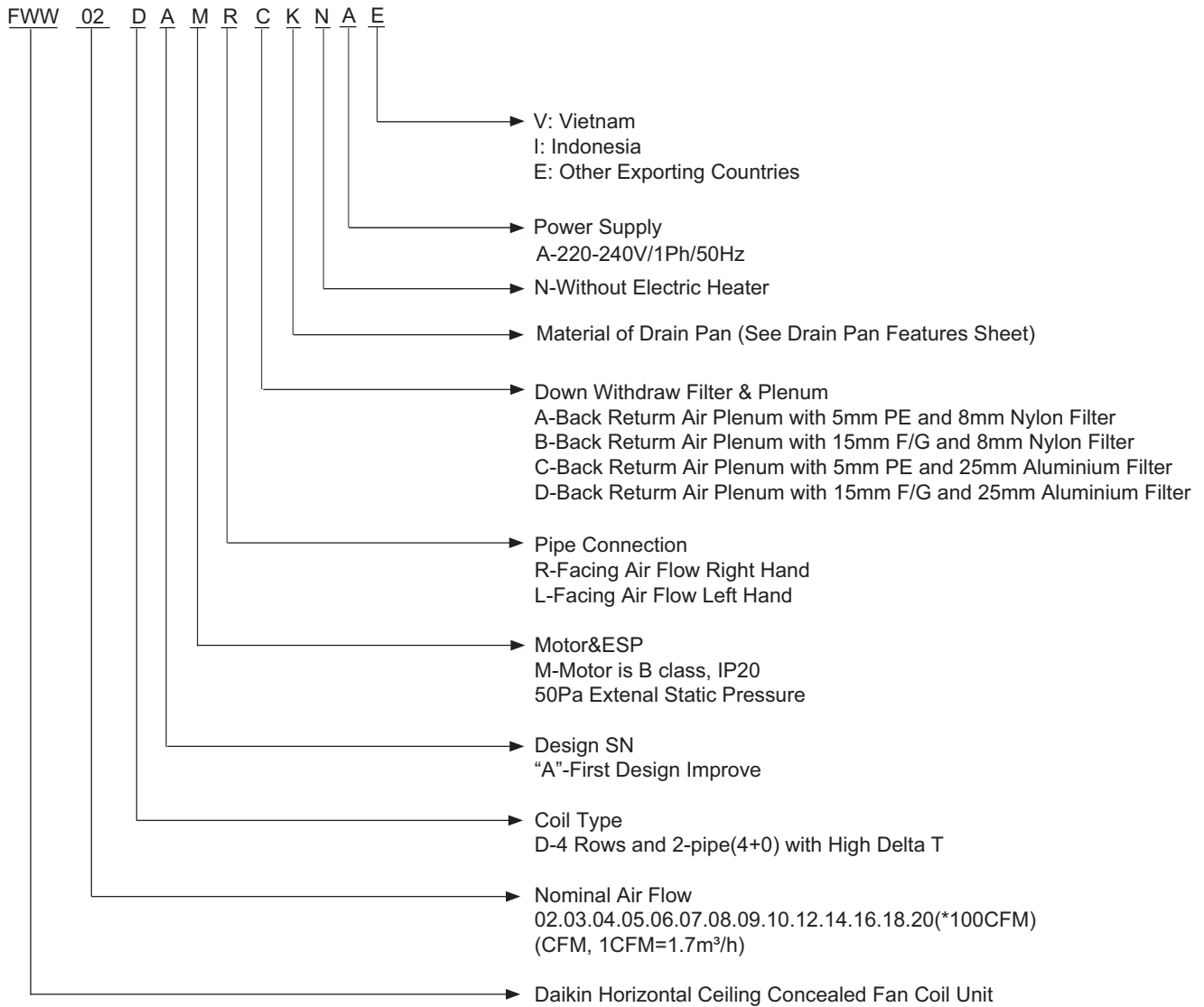

### Drain Pan Features Sheet

Code	Material	Length	Insulation
A	standard	standard	7mm PE
B	standard	+100mm	7mm PE
E	SUS	standard	7mm PE
F	SUS	+100mm	7mm PE
K	standard	standard	6mm class"0" armaflex
P	standard	+100mm	6mm class"0" armaflex
L	SUS	standard	6mm class"0" armaflex
Q	SUS	+100mm	6mm class"0" armaflex

# Technical Specifications



## Ceiling Concealed Unit FWW-DA

### District Cooling Unit/2-pipe/4 Rows

	MODEL	FWW02DA	FWW03DA	FWW04DA	FWW05DA	FWW06DA	FWW07DA	FWW08DA	FWW10DA	FWW12DA	FWW14DA	FWW16DA	FWW18DA	FWW20DA
Air flow (m <sup>3</sup> /h)	High	390	510	650	790	1010	1170	1200	1510	1770	1890	2220	2550	3280
	Medium	370	490	620	750	990	1140	1170	1490	1730	1860	2090	2530	3140
	Low	310	410	520	650	860	1020	1000	1360	1550	1690	1700	2130	2560
ESP (Pa)	High	55	54	56	52	53	54	53	52	53	52	56	53	54
	Medium	50	50	50	50	50	50	50	50	50	50	50	50	50
	Low	35	36	36	38	38	40	40	42	40	41	34	36	33
Total cooling capacity (W)	High	2087	2179	3238	3939	4567	5453	5527	7333	8505	8785	9947	11598	14422
	Medium	2038	2160	3187	3860	4540	5323	5400	7234	8399	8723	9630	11587	14053
	Low	1748	1933	2822	3537	4165	4977	4907	6860	7742	8327	8500	10531	12498
Sensible cooling capacity (W)	High	1473	1512	2184	2677	3285	3859	3944	5178	6064	6311	7309	8468	10647
	Medium	1423	1484	2137	2608	3259	3772	3864	5123	5931	6255	7031	8466	10347
	Low	1201	1307	1856	2354	2954	3504	3461	4807	5396	5902	6072	7550	8988
Water pressure drop (Pa)	High	4.8	5.3	12	18.7	8.7	13	13.4	13.5	18.2	19.4	16.3	22.6	24.3
	Medium	4.7	5.3	11.8	18.2	8.7	12.7	13.1	13.3	17.8	19.1	15.5	22.6	23.4
	Low	4.1	4.7	10.2	16.3	7.9	11.6	11.6	12.4	15.2	17.5	12.8	19.3	19.5
Rated power input (W)	High	62	89	117	122	159	165	177	312	270	324	481	654	690
	Medium	59	83	107	114	142	159	167	285	253	298	436	558	635
	Low	52	67	85	102	124	156	157	239	230	270	390	452	575
Lw outlet duct (dB(A)) <sup>(1)</sup>	High	51	56	57	59	60	61	63	63	64	65	68	69	70
	Medium	50	55	56	58	60	60	62	63	63	65	66	68	69
	Low	46	52	53	55	57	59	59	60	60	63	65	65	66
Lw inlet + rad (dB(A)) <sup>(1)</sup>	High	57	59	60	62	63	64	66	67	67	69	70	72	73
	Medium	56	58	59	61	63	63	66	66	67	68	69	72	72
	Low	52	55	56	58	60	62	63	64	64	65	66	68	69
Sound pressure level (dB(A)) <sup>(2)</sup>	High	42.5	43.5	44	45	47.5	47.5	48	48.5	50.5	51.5	52	53.5	57
	Medium	41.5	43	43	44	46.5	46.5	47.5	48	49.5	51	51	53	56
	Low	37	40	41	42	43.5	44.5	44.5	46.5	47	48	47	49.5	52
Coil														
Tube material	Copper													
Fin material	Hydrophilic aluminum 0.11mm													
Filter withdraw														
25mm aluminum filter	Bottom withdraw													
Max. working pressure	1.6MPa													
Cooling water pipe size	Rc 3/4 Female thread													
Condensation water pipe size	R3/4 Male thread													
Fan														
Type	Galvanized steel double stage impeller forward centrifugal													
Quantity	1	1	2	2	2	2	2	3	4	4	3	3	4	4
Motor														
Type	3 speed permanent split capacitor motor													
Quantity	1	1	1	1	1	1	1	2	2	2	2	2	2	2
Insulation class	IP20/B													

#### NOTES:

- 1) THE AIR FLOW IS DRY AIR FLOW TESTED ON STANDARD AIR CONDITION WITHOUT WATER IN COIL.
- 2) THE COOLING CAPACITY ARE TESTED UNDER FOLLOWING CONDITION:  
ENTERING AIR DB/WB: 24°C DB/18°C, WATER INLET 5.5°C, WATER OUTLET 14.5°C.
- 3) ALL PERFORMANCE ARE TESTED UNDER 220V~/50HZ WITH BACK PLENUM AND 25MM ALUMINUM FILTER.
- 4) WHEN THE WATER CONNECT DIRECTION IS CHANGED IN FIELD, THE CAPACITY SHOULD BE REDUCED BY 15%.
- 5) PERFORMANCE OF SPECIFIED CONDITION CAN BE CALCULATED BY OUR SOFTWARE.
- 6) <sup>(1)</sup>SOUND POWER MEASURED BASED ON EUROVENT STANDARD.
- 7) <sup>(2)</sup>SOUND PRESSURE MEASURED AT 1M IN FRONT OF THE UNIT AND 1M BELOW THE VERTICAL CENTER LINE OF THE UNIT. AND TESTED IN SEMI-ANECHOIC ROOM, WITH BACKGROUND SOUND PRESSURE LEVEL: 11.5DB (A).
- 8) THE CERTIFIED PERFORMANCES, CONDITIONS AND THE CERTIFICATION OF THE SOFTWARE HAVE TO BE VERIFIED IN [WWW.EUROVENT-CERTIFICATION.COM](http://WWW.EUROVENT-CERTIFICATION.COM).



# Dimensions

## Ceiling Concealed Unit FWW-DA

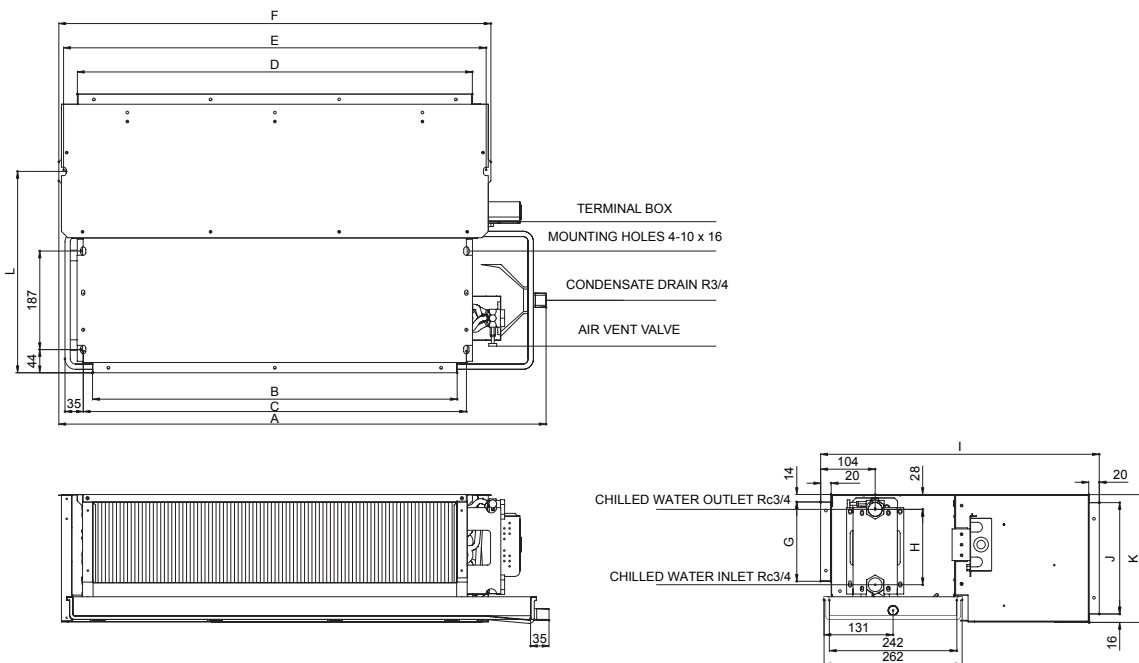

Model	A	B	C	D	E	F	G	H	I	J	K	L	M	Package dimension (L×H×W) mm	Net weight (kg)	Gross weight (kg)
FWW02DA	675	452	487	469	522	540	151	143	529	211	243	382	72	691×560×258	16	19
FWW03DA	675	452	487	469	522	540	151	143	529	211	243	382	72	691×560×258	16	19
FWW04DA	825	592	627	649	702	720	151	143	529	211	243	382	72	841×560×258	21	24
FWW05DA	925	692	727	749	802	820	151	143	529	211	243	382	72	941×560×258	22	25
FWW06DA	995	772	807	789	842	860	151	143	529	211	243	382	72	1011×560×258	24	28
FWW07DA	1095	872	907	889	942	960	151	143	529	211	243	382	72	1111×560×258	28	31
FWW08DA	1095	872	907	889	942	960	151	143	529	211	243	382	72	1111×560×258	28	31
FWW10DA	1425	1202	1237	1219	1272	1290	151	143	529	211	243	382	72	1441×560×258	39	43
FWW12DA	1525	1302	1337	1359	1412	1420	151	143	529	211	243	382	72	1541×560×258	44	48
FWW14DA	1525	1302	1337	1359	1412	1420	151	143	529	211	243	382	72	1541×560×258	44	48
FWW16DA	1425	1202	1237	1239	1289	1307	201	194	599	266	297	413	82	1441×630×312	51	55
FWW18DA	1525	1302	1337	1322	1372	1390	201	194	599	266	297	413	82	1541×630×312	52	58
FWW20DA	1825	1602	1637	1622	1672	1690	201	194	599	266	297	413	82	1841×630×312	62	68

## Exploded-view & Part List

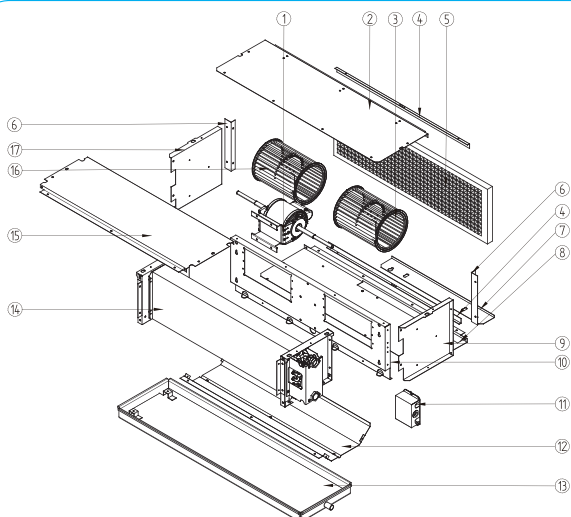

Item	Description
1	Motor
2	Top Panel for Air Return Plenum
3	Blower Left
4	Flange Top/bottom for Air Return Plenum
5	Filter
6	Flange Left/right for Air Return Plenum
7	Filter Cover
8	Bottom Panel for Air Return Plenum
9	Side Panel Right For Air Return Plenum
10	Fan Deck
11	Terminal Box
12	Deflector
13	Drain Pan
14	Coil Assy
15	Top Panel
16	Blower Right
17	Side Panel Left for Air Return Plenum

# Nomenclature

## Ceiling Exposed Unit for District Cooling FWW-AA

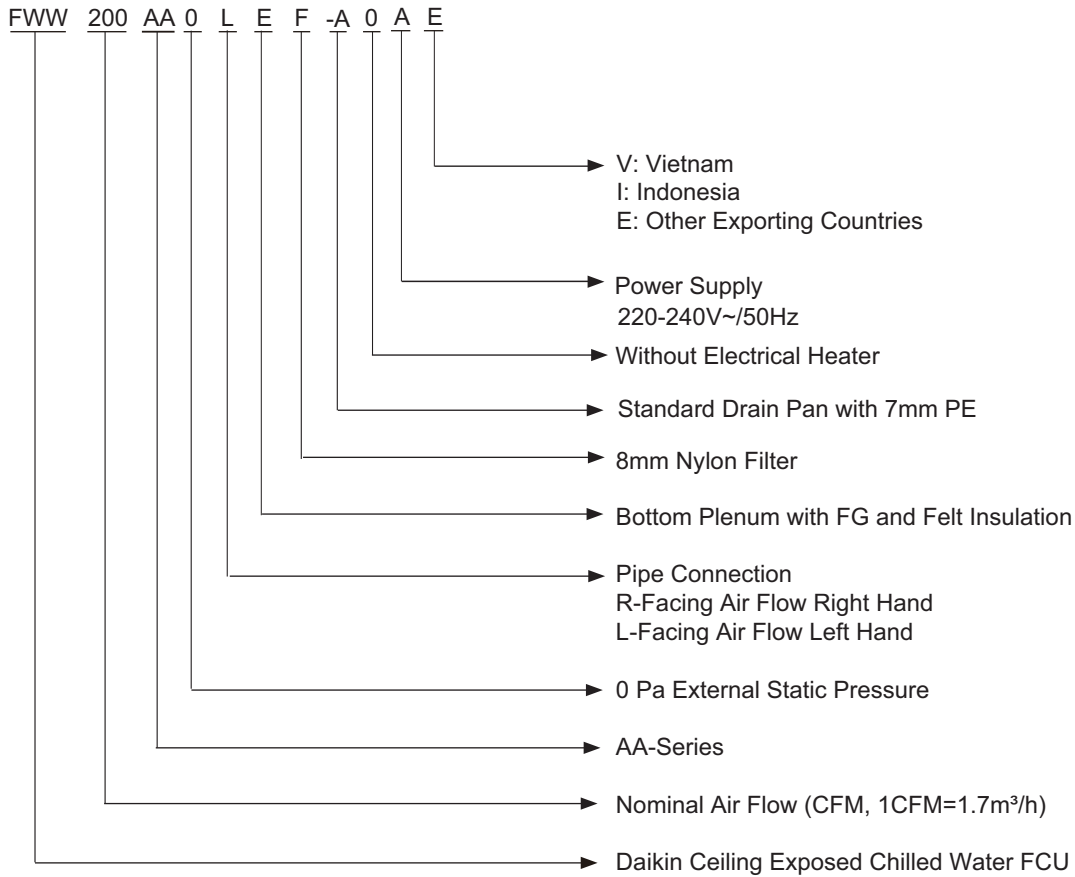

GENERAL

FWW-VC

FWW-C/F/H

FWW-DA

FWW-AA

FUW-A

WIRING

INSTALLATION

# Technical Specifications

## Ceiling Exposed Unit FWW-AA

### District Cooling Unit/2-pipe/4 Rows

MODEL			200AA	300AA	400AA	600AA	800AA	1000AA	1200AA	1400AA
Air flow	High	m <sup>3</sup> /h	340	510	680	1020	1360	1700	2040	2380
	Medium	m <sup>3</sup> /h	279	418	558	836	1115	1394	1673	1952
	Low	m <sup>3</sup> /h	170	255	340	510	680	850	1020	1190
Total cooling capacity		W	2125	3385	4390	6207	8096	10165	11066	13744
Sensible capacity		W	1233	2059	2848	4179	5572	7125	7961	9770
Water flow		m <sup>3</sup> /h	0.21	0.33	0.43	0.6	0.79	0.99	1.07	1.32
Water pressure drop		kPa	5	13	22	16	16	25	20	29
Rated power input		W	39	53	72	107	142	183	217	239
Rated running current		A	0.18	0.24	0.33	0.48	0.65	0.83	0.99	1.09
Sound pressure level	High	dB(A)	36	40	43	46	46	50	50	51
	Medium	dB(A)	32	36	36	42	42	47	47	46
	Low	dB(A)	23	25	29	30	32	38	36	37
Coil										
Tube material		Copper								
Fin material		Hydrophilic aluminum 0.11mm								
Filter withdraw										
Bottom return		8mm nylon filter								
Max. working pressure		Bottom withdraw 1.6MPa								
Cooling water pipe size		Rc 3/4 Female thread								
Condensation water pipe size		R3/4 Male thread								
Fan										
Type		Galvanized steel double stage impeller forward centrifugal								
Quantity		1	2	2	2	3	4	4	4	4
Motor										
Type		3 speed permanent split capacitor motor								
Quantity		1	1	1	1	2	2	2	2	2
Insulation class		IP20/B								

#### NOTES:

- 1) ALL SPECIFICATIONS ARE SUBJECT TO CHANGE BY THE MANUFACTURER WITHOUT PRIOR NOTICE.  
ALL STANDARD UNITS ARE WITH BACK AIR PLENUM AND BOTTOM REMOVAL FILTERS;
- 2) THE AIR FLOW IS TESTED AT 20°C DB WITHOUT WATER IN COIL.
- 3) THE COOLING CAPACITY ARE BEING TESTED UNDER FOLLOWING CONDITION:  
H SPEED, ENTERING AIR DB/WB: 27°C/19.5°C, WATER INLET 5.5°C, WATER OUTLET 14.5°C
- 4) SOUND PRESSURE MEASURED AT 1M IN FRONT OF THE UNIT AND 1M BELOW THE VERTICAL CENTER LINE OF THE UNIT,  
AND TESTED IN SEMI-ANECHOIC ROOM, WITH BACKGROUND SOUND PRESSURE LEVEL: 11.5DB (A).
- 5) ALL PERFORMANCE ARE TESTED UNDER 220V~/50HZ.
- 6) WHEN THE WATER CONNECT DIRECTION IS CHANGED IN FIELD,THE CAPACITY SHOULD BE REDUCED BY 15%.
- 7) FOR MEDIUM SPEED, THE CAPACITY IS ABOUT 87% OF HIGH SPEED.  
FOR LOW SPEED, THE CAPACITY IS ABOUT 60% OF HIGH SPEED.

GENERAL

FWW-VC

FWW-C/F/H

FWW-DA

FWW-AA

FUW-A

WIRING

INSTALLATION

# Technical Specifications

## Ceiling Exposed Unit FWW-AA

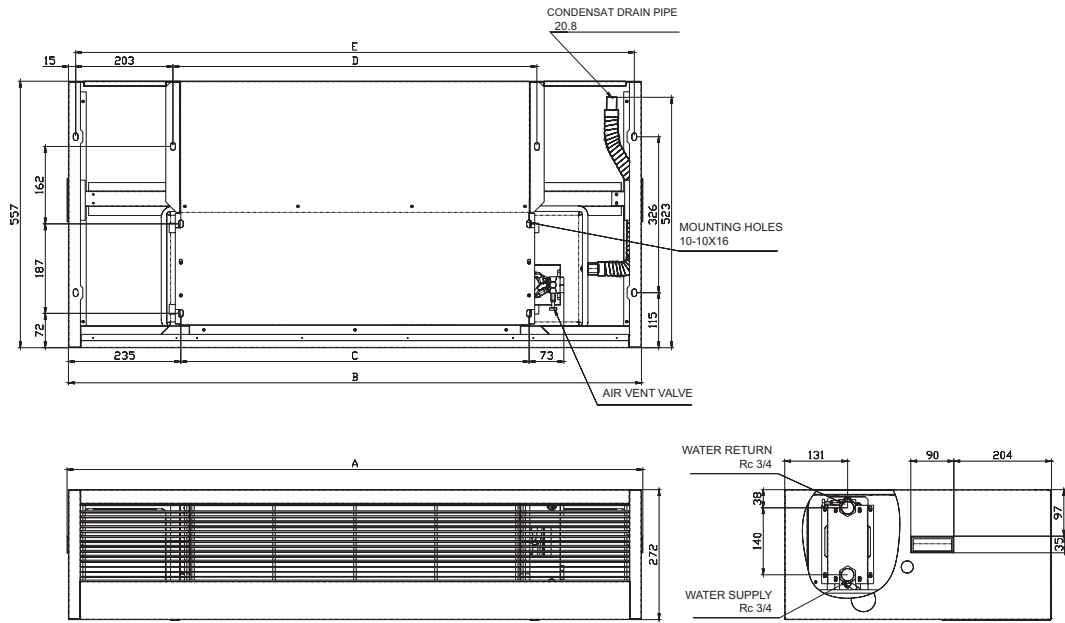

Unit: mm

Unit model	A	B	C	D	E	Package dimension (L×H×W) mm	Net weight (kg)	Gross weight (kg)
FWW200AA	963	957	488	520	927	970×565×300	30	32
FWW300AA	1103	1097	628	660	1067	1110×565×300	35	38
FWW400AA	1203	1197	728	760	1167	1210×565×300	39	42
FWW600AA	1383	1377	908	940	1347	1390×565×300	44	48
FWW800AA	1713	1707	1238	1270	1677	1720×565×300	61	66
FWW1000AA	1813	1807	1338	1370	1777	1820×565×300	66	71
FWW1200AA	2013	2007	1538	1570	1977	2020×565×300	73	78
FWW1400AA	2273	2267	1798	1830	2237	2280×565×300	83	89

## Exploded-View & Part List

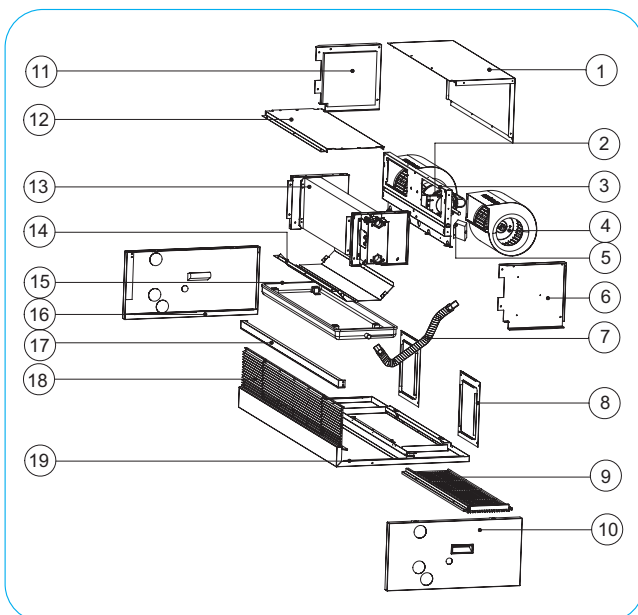

Item	Description
1	Top panel for air return plenum
2	Motor
3	Fan deck
4	Fan
5	Terminal box
6	Right side plate of air return box
7	Condensate drain pipe
8	Back support plate
9	Filter and grille
10	Right side plate
11	Left side plate of return air box
12	Top plate
13	Coil assy
14	Deflector
15	Drain pan
16	Left side plate
17	Front cross beam
18	Air supply grille
19	Bottom panel

# Nomenclature

## High ESP Ceiling Unit FUW-A

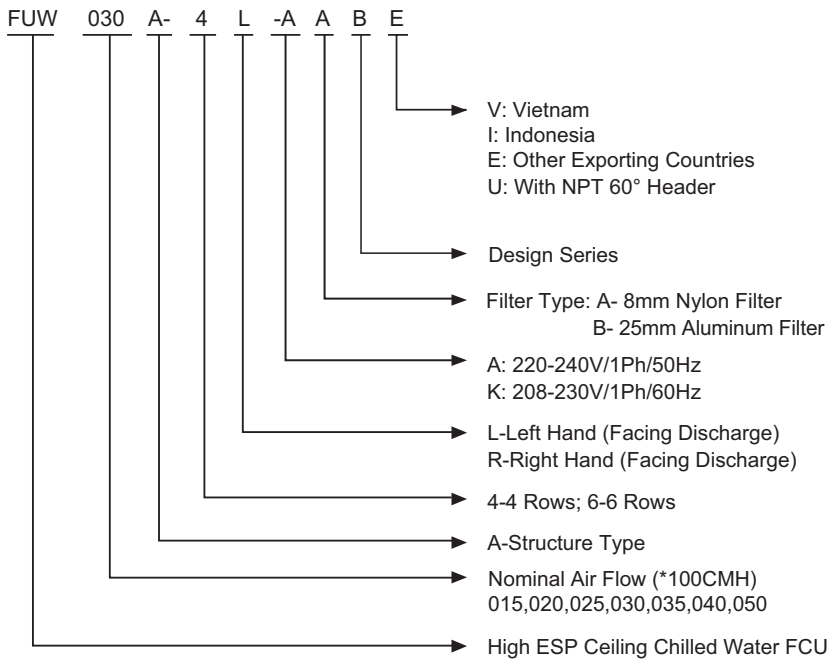

## Exploded-View & Part List

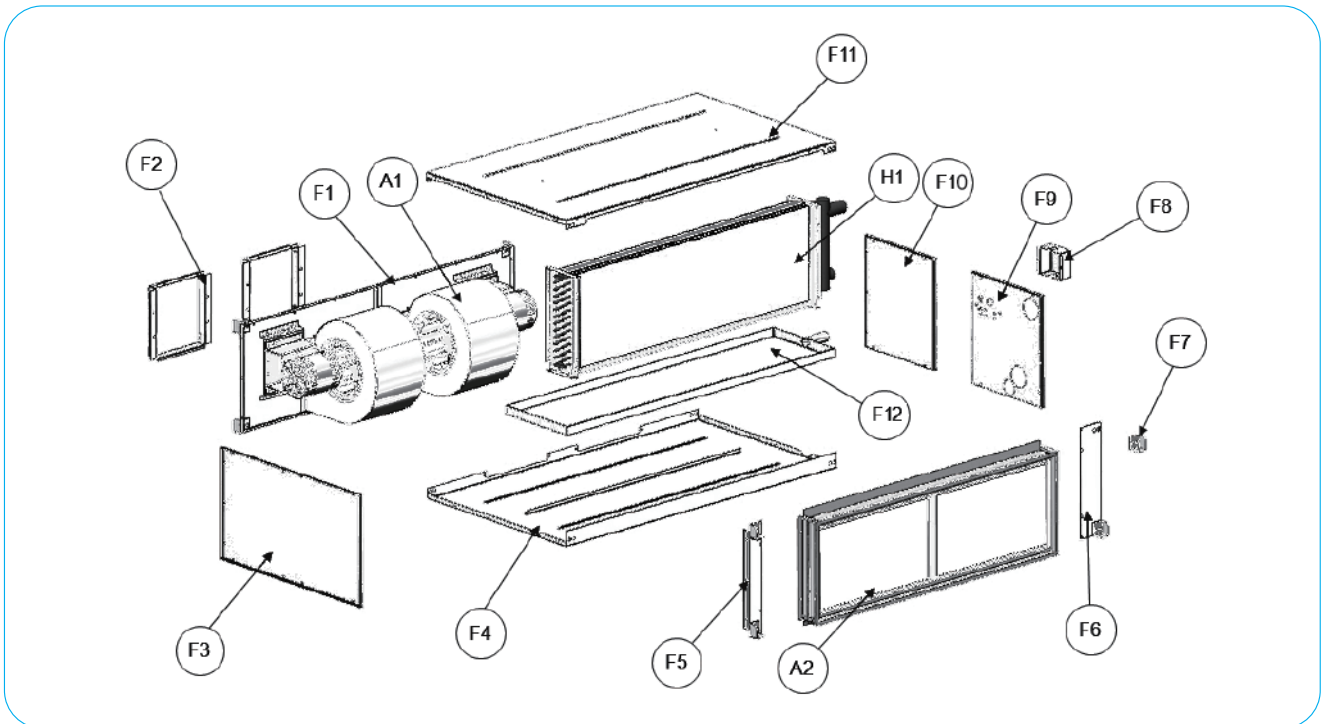

<b>A1</b>	FAN MOTOR ASSY.	<b>F4</b>	BASE PANEL ASSY.	<b>F9</b>	SIDE PANEL DRAIN
<b>A2</b>	FILTER ASSY.	<b>F5</b>	R COIL BAFFLE	<b>F10</b>	SIDE PANEL ACCESS
<b>F1</b>	FRONT PANEL	<b>F6</b>	L COIL BAFFLE	<b>F11</b>	TOP PANEL
<b>F2</b>	COLLAR ASSY.	<b>F7</b>	TOP FIX	<b>F12</b>	DRAIN PAN ASSY.
<b>F3</b>	SIDE PANEL WIDE	<b>F8</b>	TERMINAL BOX	<b>H1</b>	COIL ASSY.

# Technical Specifications

## High ESP Ceiling Unit FUW-A

### Standard Unit/2-pipe/4 or 6 Rows

Model			FUW015A	FUW020A	FUW025A	FUW030A	FUW035A	FUW040A	FUW050A
Nominal air flow		m <sup>3</sup> /h	1500	2000	2500	3000	3500	4000	5000
External static pressure (ESP)		Pa	70	100	100	120	120	150	150
Power supply		V/Ph/Hz	220-240/1/50 208-230/1/60						
Nominal capacity	Cooling	4 Rows(return air)	7	12	13	17	20	23	30
		4 Rows(fresh air)	18	27	33	41	47	53	64
		6 Rows(fresh air)	10	14	18	22	26	30	38
	Heating	4 Rows(return air)	24	33	42	50	57	65	78
		4 Rows(fresh air)	13	19	22	27	32	36	46
		6 Rows(fresh air)	22	30	37	44	52	59	75
Water flow	Cooling	4 Rows(return air)	16	22	27	33	38	44	55
		4 Rows(fresh air)	26	35	43	52	61	70	88
		6 Rows(fresh air)	0.34	0.57	0.64	0.79	0.93	1.08	1.42
	Heating	4 Rows(return air)	0.88	1.29	1.59	1.93	2.25	2.51	3.05
		4 Rows(fresh air)	0.48	0.67	0.86	1.05	1.23	1.43	1.83
		6 Rows(fresh air)	1.15	1.59	2.01	2.38	2.72	3.08	3.72
Water pressure drop	Cooling	4 Rows(return air)	0.31	0.44	0.53	0.64	0.75	0.87	1.1
		4 Rows(fresh air)	0.51	0.72	0.87	1.05	1.23	1.41	1.78
		6 Rows(return air)	0.38	1.51	0.65	0.78	0.91	1.04	1.31
	Heating	6 Rows(fresh air)	0.61	0.83	1.03	1.24	1.45	1.67	2.08
		4 Rows(return air)	1	26	5	9	13	19	37
		4 Rows(fresh air)	7	80	29	46	60	66	77
220-240V~/50Hz	Rated power input	4 Rows	4	8	14	22	33	47	87
		6 Rows	18	37	65	79	87	95	112
		6 Rows(fresh air)	1	14	3	5	8	11	20
	Rated running current	4 Rows	2	34	8	13	19	27	49
		6 Rows	2	4	7	11	16	23	41
		6 Rows(fresh air)	5	10	17	26	38	53	93
208-230V~/60Hz	Rated power input	4 Rows	368	488	977	790	874	1335	1864
		6 Rows	407	680	886	830	916	1450	1646
		6 Rows	1.67	2.25	4.48	3.66	4.13	6.25	8.52
	Rated running current	4 Rows	1.87	3.18	4.07	2.95	4.23	5.54	7.56
		6 Rows	305	455	601	687	833	1060	1220
		6 Rows	307	509	625	765	860	1017	1217
Sound pressure level	4 Rows	1.33	2.01	2.75	2.98	3.89	3.96	5.55	
	6 Rows	1.34	2.22	2.68	3.45	3.91	4.44	5.31	
	High	44.1	50.6	55.7	52.5	53.5	53.6	57	
Structure	Medium	40.7	48	52.2	50.5	52.1	51.5	56	
	Low	37.7	45.1	48.4	48.5	50.2	49.5	54.9	
	Type	Galvanized steel coated with electrostatic spraying. Internal guded with Insulator PE							
Coil	Type	Corrugated aluminum fin mechanically bonded with copper tube							
	Max. working pressure(MPa)	1.6							
	Inlet/outlet pipe	R1½"							
	Condensing water pipe	R¾"							
Filter withdraw	8mm nylon filter	Side withdraw							
	25mm aluminum filter	Side withdraw							
Fan	Type/material	Centrifugal forward curved blower and galvanized steel							
	Fan no.	1				2			
Motor	Type	Single phase capacitor running							
	Quantity	1				2			
	Insulation class	IP20 B							

#### NOTES:

- 1) ALL SPECIFICATIONS ARE SUBJECT TO CHANGE BY THE MANUFACTURER WITHOUT PRIOR NOTICE.
- 2) THE AIR FLOW IS TESTED AT 20°C DB WITHOUT WATER IN COIL.
- 3) THE COOLING CAPACITY ARE BEING TESTED UNDER FOLLOWING CONDITION:  
RETURN AIR COOLING CONDITIONS: 27°C/19.5°C WB; FRESH AIR COOLING CONDITIONS: 34°C DB/28°C WB  
COOLING WATER ENTERING/LEAVING CONDITIONS: 7°C/12°C  
RETURN AIR HEATING CONDITION: 21°C DB; FRESH AIR HEATING CONDITION: 0°C DB;  
HEATING WATER ENTERING/LEAVING CONDITIONS: 60°C/50°C
- 4) SOUND PRESSURE MEASURED AT 1M IN FRONT OF THE UNIT AND 1M BELOW THE VERTICAL CENTER LINE OF THE UNIT, AND TESTED IN SEMI-ANECHOIC ROOM WITH BACKGROUND SOUND PRESSURE LEVEL: 11.5DB(A)
- 5) ALL PERFORMANCE ARE TESTED UNDER 220V~/50HZ AND UNIT COUPLE WITH 8MM NYLEN FILTER.
- 6) THE PARAMETERS ABOVE ARE MEASURED AT THE ALTITUDE OF 0M ABOVE SEA LEVEL, AND MAY VARY WITH THE ALTITUDE.

# Dimensions

## High ESP Ceiling Unit FUW-A

### FUW015A, FUW020A, FUW025A

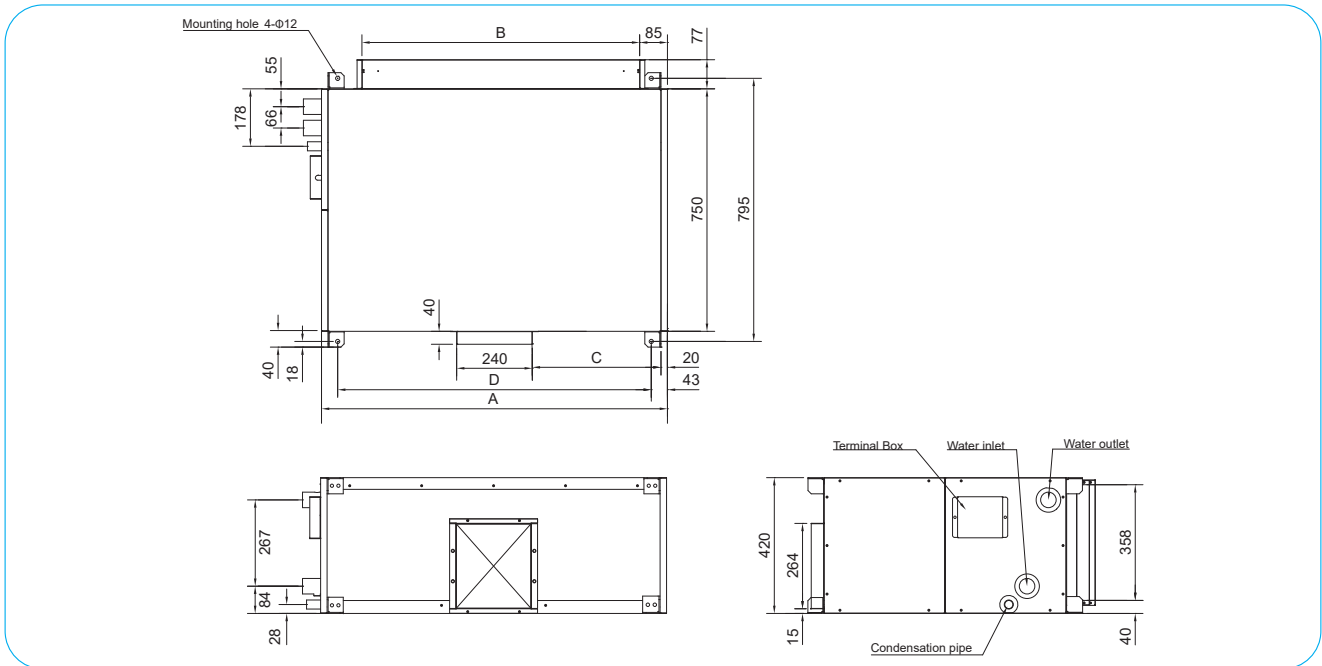

Unit: mm

Model	Dimension	A	B	C	D	Package dimension (L×H×W) mm	Net weight (kg)	
							4 rows	6 rows
FUW015A		750	540	235	667	930×590×930	76	79
FUW020A		910	700	315	827	1090×590×930	80	84
FUW025A		1070	860	395	987	1250×590×930	86	90

### FUW030A, FUW035A, FUW040A, FUW050A

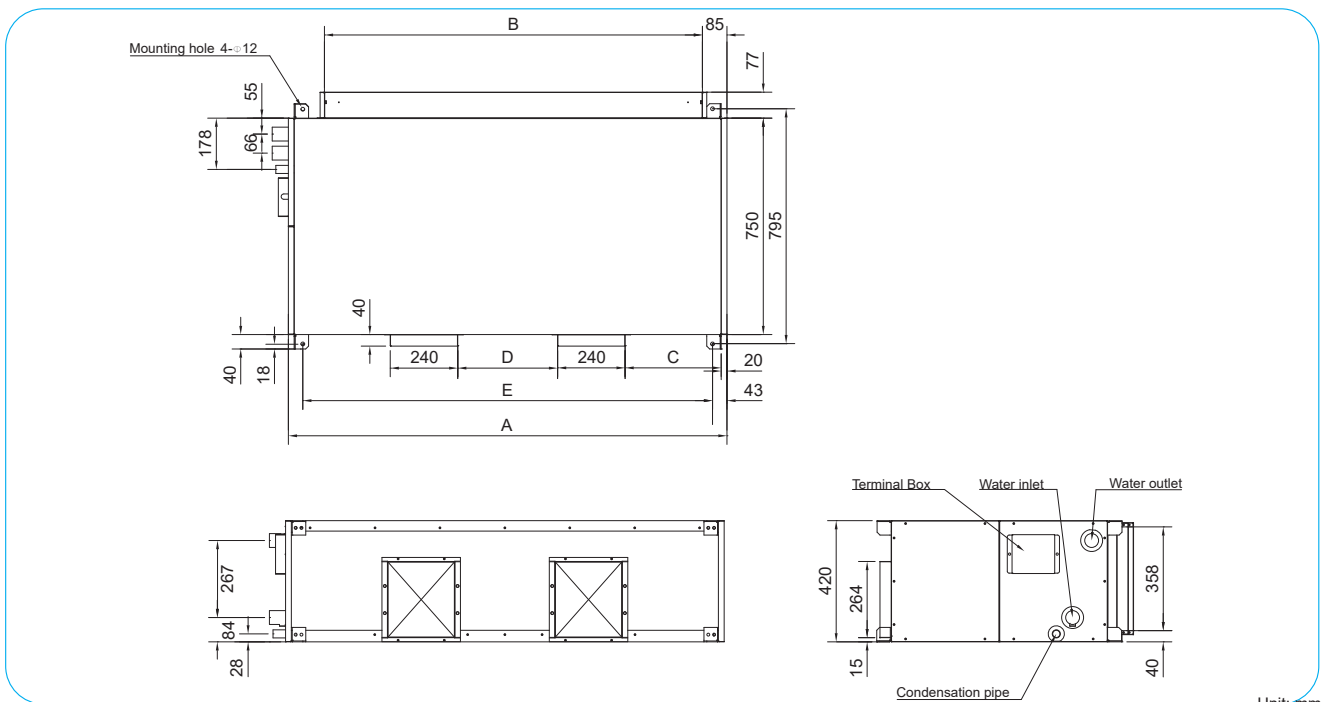

Unit: mm

Model	Dimension	A	B	C	D	E	Package dimension (L×W×H) mm	Net weight (kg)	
								4 rows	6 rows
FUW030A		1220	1010	265	170	1137	1400×590×930	92	96
FUW035A		1370	1160	320	210	1287	1540×590×930	96	101
FUW040A		1520	1310	330	340	1437	1700×590×930	102	107
FUW050A		1850	1640	395	540	1767	2030×590×930	108	113

GENERAL

FWM-VC

FWM-C/F/H

FWM-DA

FWM-AA

FUW-A

WIRING

INSTALLATION

## Electric Heating Box for FUW-A Unit

### Electric Heating Box Power

Electric Box Model	Power Supply	Capacity(kW)	Electric Box Model	Power Supply	Capacity(kW)
FUW-EH-020BOX	220-240V/1Ph/50Hz; 208-230V/1Ph/60Hz	2	FUW-EH-050BOX	220-240V/1Ph/50Hz; 208-230V/1Ph/60Hz	5
FUW-EH-030BOX	220-240V/1Ph/50Hz; 208-230V/1Ph/60Hz	3	FUW-EH-060BOX	220-240V/1Ph/50Hz; 208-230V/1Ph/60Hz	6
FUW-EH-040BOX	220-240V/1Ph/50Hz; 208-230V/1Ph/60Hz	4	FUW-EH-075BOX	220-240V/1Ph/50Hz; 208-230V/1Ph/60Hz	7.5

#### NOTES:

EACH HEATER BOX CAN ONLY BE USED FOR ONE AIR DISCHARGE DUCT.

- 1) FUW015/20/025 - ONLY ONE HEATING BOX IS REQUIRED.
- 2) FUW030/035/040/050 - NEED TO SELECT TWO BOX, AND THE HEATING CAPACITY OF EACH BOX SHOULD BE REQUIRED TOTAL CAPACITY TO DIVIDE BY TWO.

### Dimensions of Electric Heating Box

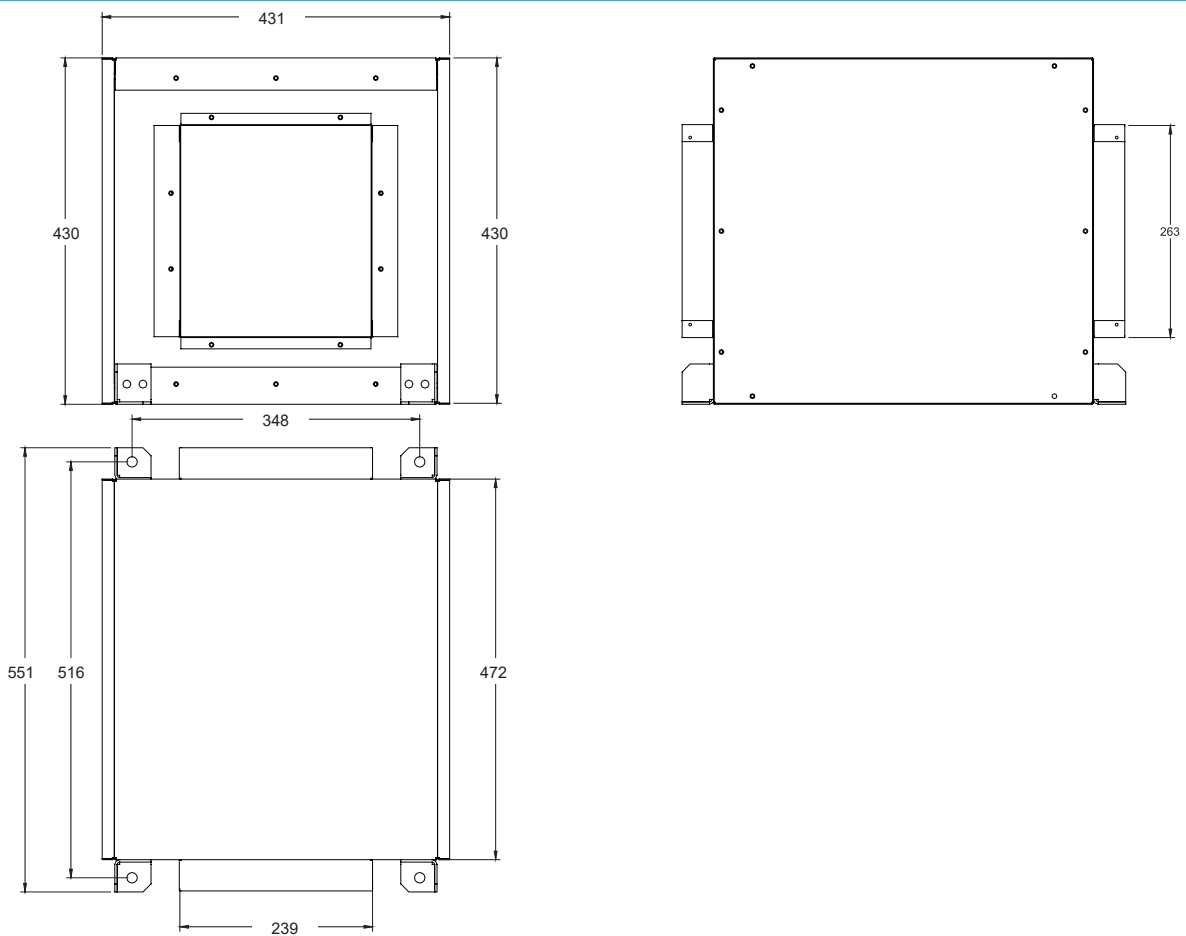

### Scheme of Electric Heating Box Installation

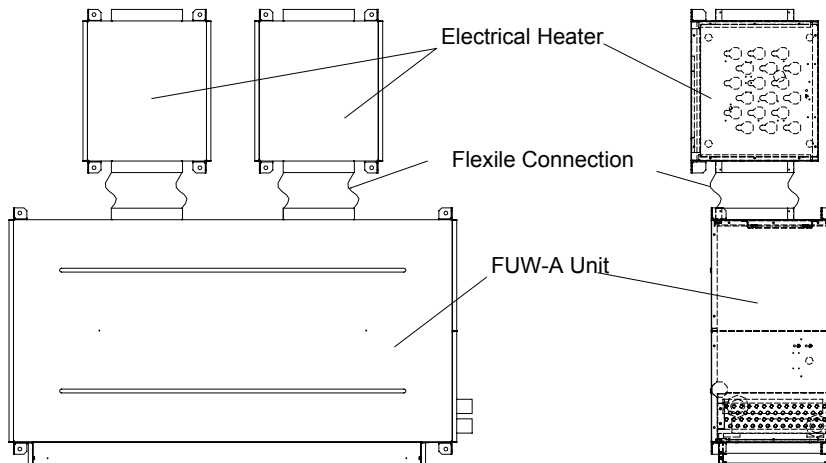



# Wiring

Electrical wiring connection must be done according to the wiring diagram on the unit.  
The unit must be GROUNDED to the earth system of the building.

All field wiring must be installed in accordance with the national wiring regulation and Fire Department regulation

## AC FCU Wiring

MODEL: FWW200~1400VC  
FWW200~1400AA

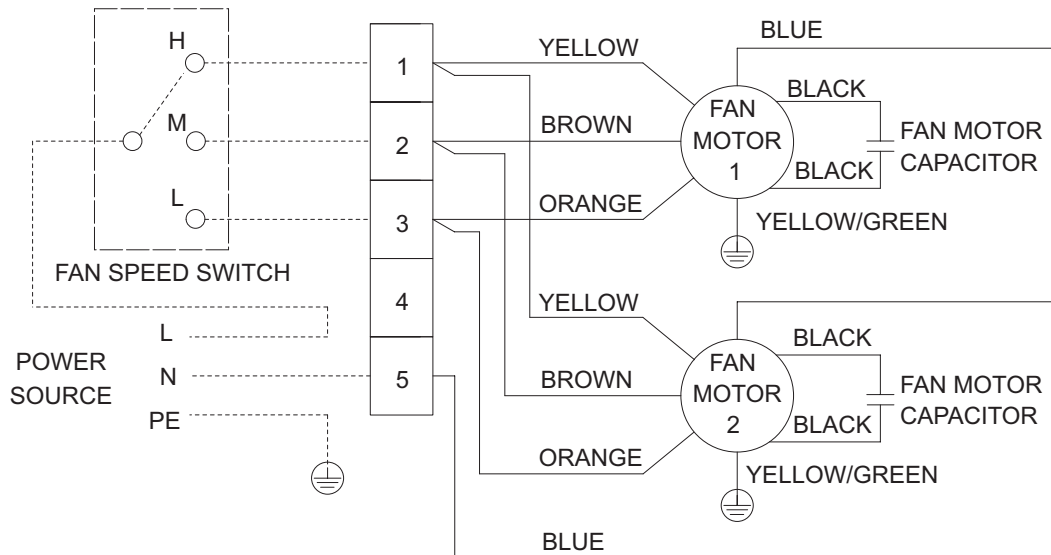

NOTE:

----- FIELD WIRING

FAN MOTOR2 APPLY TO 800~1400 UNITS.

MODEL: FWW200~1200C/F/H  
FWW02~20DA

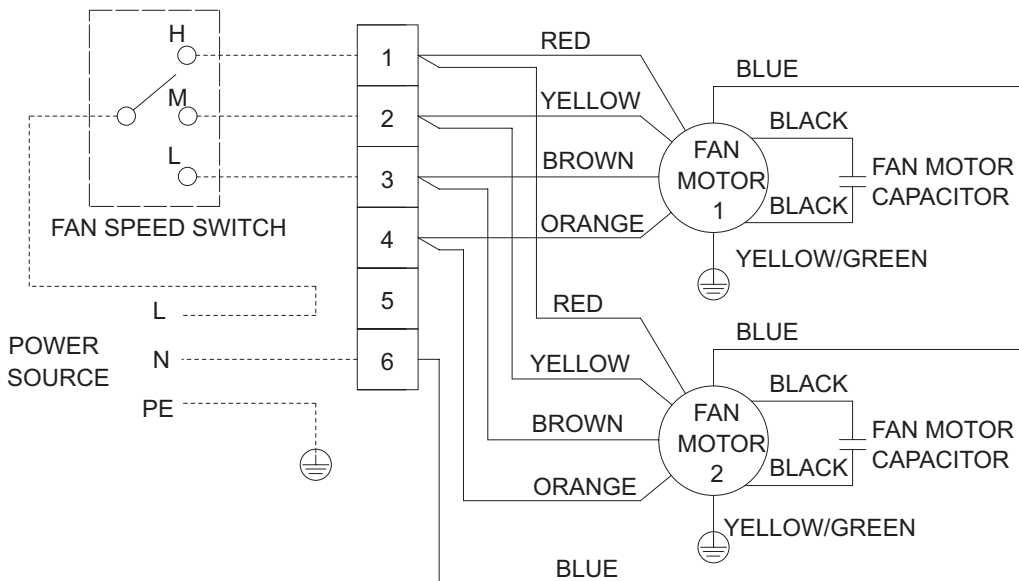

NOTE:

----- FIELD WIRING

1. FAN MOTOR2 APPLY TO FWW 800~1200C/F/H UNITS  
60Pa UNITS: (HIGH,MED,LOW) CONNECT TO (2,3,4)  
80Pa UNITS: (HIGH,MED,LOW) CONNECT TO (1,2,3)
2. FAN MOTOR2 APPLY TO FWW10~16DA UNITS  
(HIGH,MED,LOW) CONNECT TO (1,2,3)

MODEL: FWW1400~1800C/F

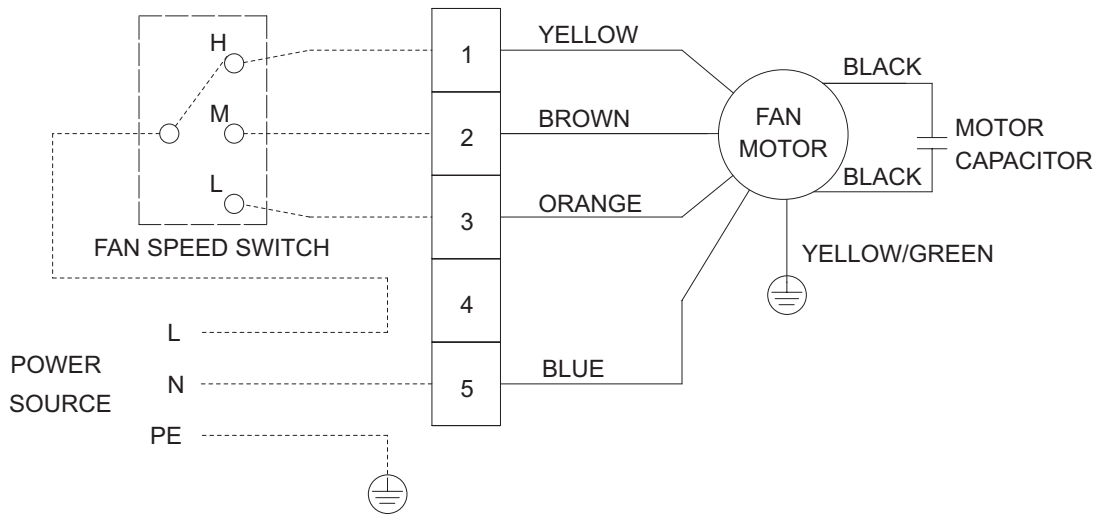

NOTE:

----- FIELD WIRING

MODEL: FUW-A

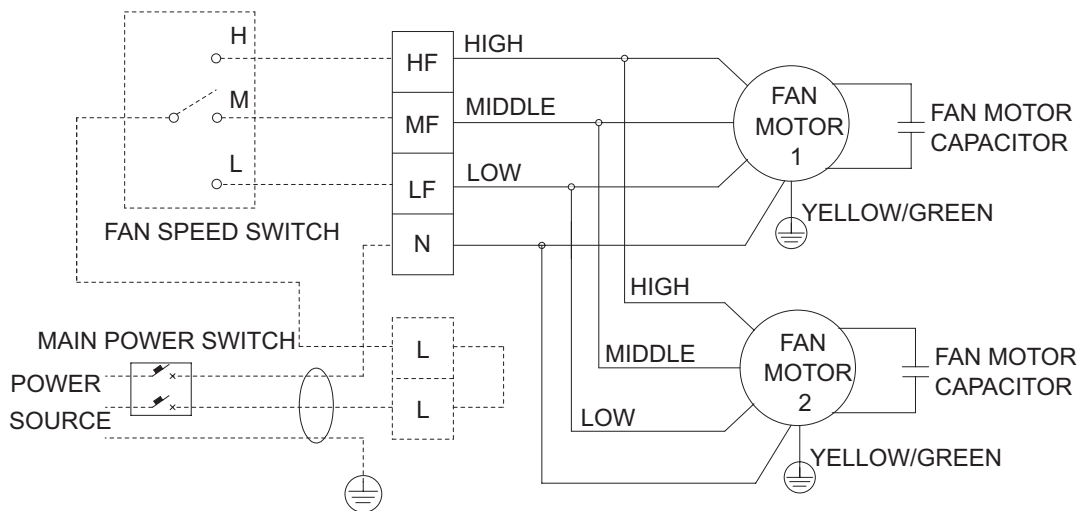

NOTE:

----- FIELD WIRING

FAN MOTOR2 APPLY TO FUW030A/035A/040A/050A UNITS.

LF: FAN SPEED LOW  
 MF: FAN SPEED MIDDLE  
 HF: FAN SPEED HIGH

## DCBL FCU Wiring

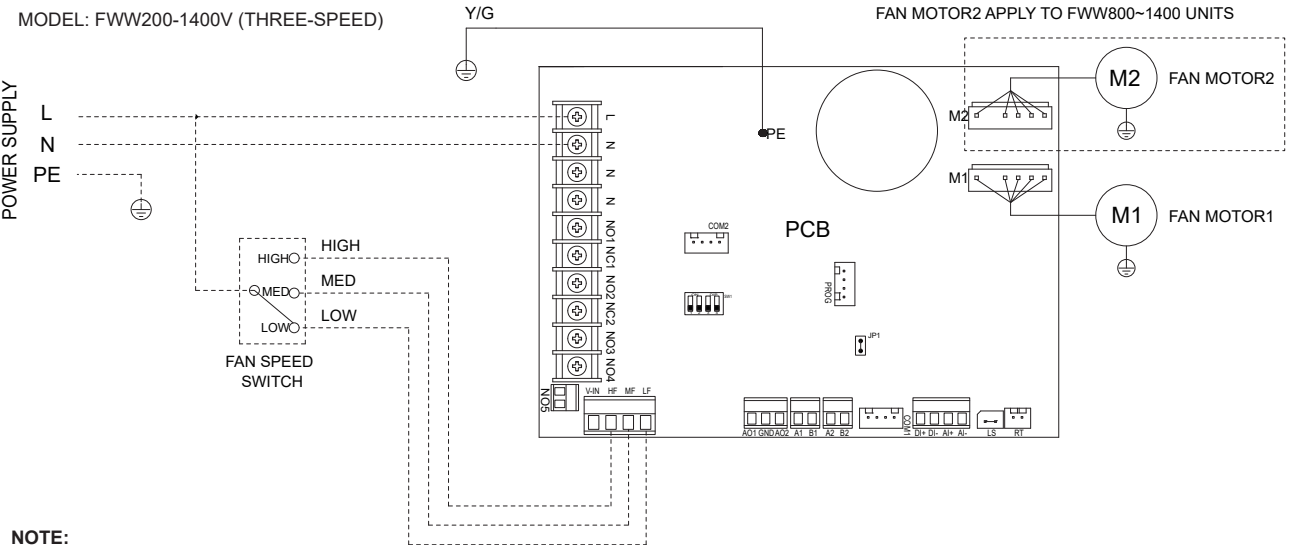

### NOTE:

1. Power cable wiring sequence, please strictly follow the wiring diagram!
2. The PCB board program has been matched with the unit motor and unit static pressure, and it is forbidden to change without authorization.
3. The PCB board black fence terminal block withstands maximum torque  $\leq 0.8\text{N}\cdot\text{M}$ .
4. The unit solenoid valve is controlled by the customer's own wiring during the three-speed control.

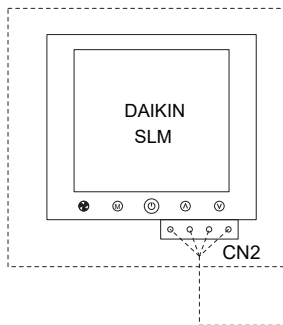
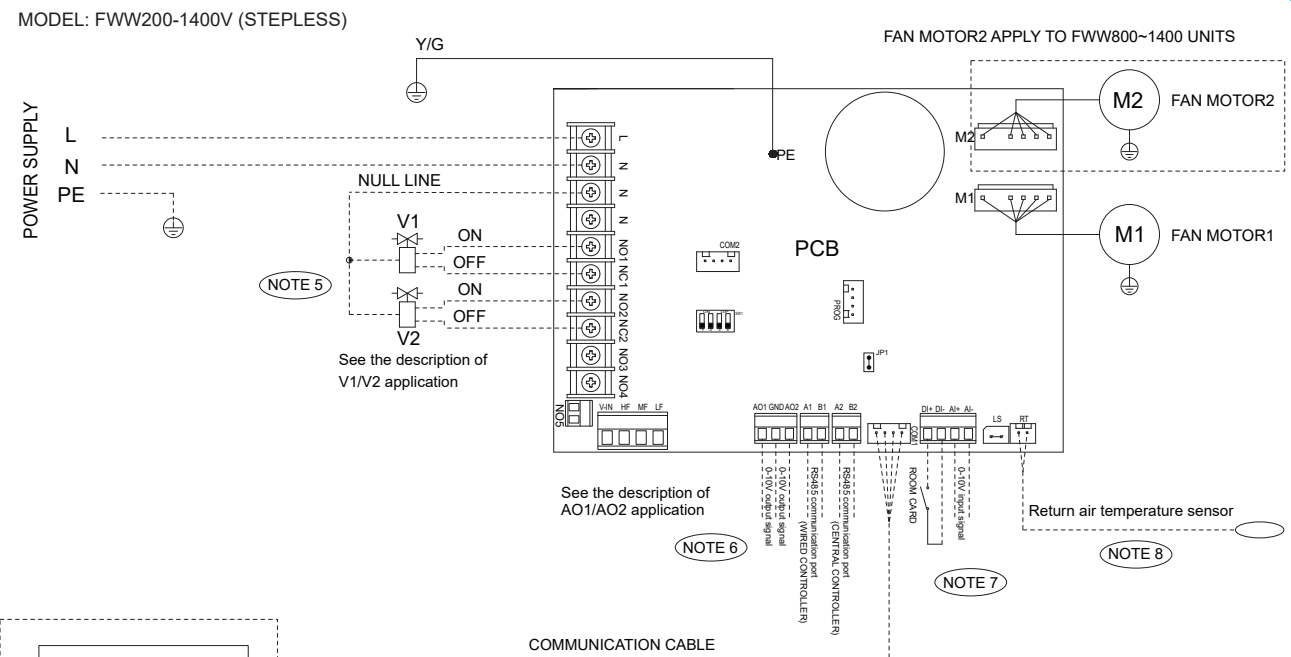

### DESCRIPTION:

1. Unit type solenoid valve/port	Two-pipe	Four-pipe
V1/AO1	Cold/Hot water valve	Cold water valve
V2/AO2	—	Hot water valve

2. LS port is shorted by default;
3. JP1 jumper is closed by default.

### SYMBOL DESCRIPTION:

PCB	DC brushless motor power board
M1/M2	Brushless DC motor

- FACTORY WIRING  
- - - FIELD WIRING

### NOTE:

5. Figure V1 and V2 are the three-line valve mode, NC1 and NC2 ports are not wired when two-line valve is used.
6. AO1 and AO2 are proportional valve ports.
7. When the customer uses 0-10V input signal to control the fan, the PCB solenoid valve control signal port and room card function are invalid.
8. RT port can be connected to return air temperature sensor, which is not standard.

# INSTALLATION

## RECEIVING

All units leaving the factory have been inspected to ensure the shipment of high quality products and reasonable means are utilized to properly pack the fan coil units to protect them in transit.

Carefully inspect all shipments immediately upon delivery. When damage is visible, note this fact on the carrier's freight bill and request that the carrier send a representative to inspect the damage. This may be done by telephone or in person, but should always be confirmed in writing.

The shipment should be unpacked in the presence of the agent so that the damage or loss can be determined. The carrier's agent will make an inspection report and a copy will be given to the consignee for forwarding to the carrier with a formal claim.

## LOCATION

Before installation, please check the following:

There must be enough space for unit installation and maintenance. Please refer to the outline and dimensions and fig.1 for the minimum distance between the unit and obstacle.

In case of installation in free blow, the unit must be installed at a minimum height of 2.5m to avoid contact with the appliance.

Please ensure enough space for piping connection and electrical wiring.

Please make sure that the hanging rods can support weight of the unit.

## INSTALLATION

The unit is designed for concealed ceiling installation.

There are holes on the top of the unit for hanging. Please refer to Fig.1. Fig.2 and Fig.3.

Make sure that the top of the unit is level.

Fig.1

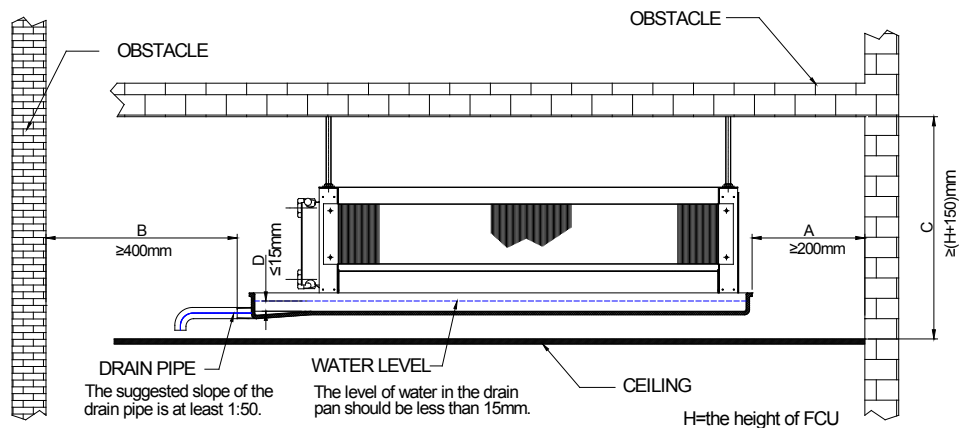
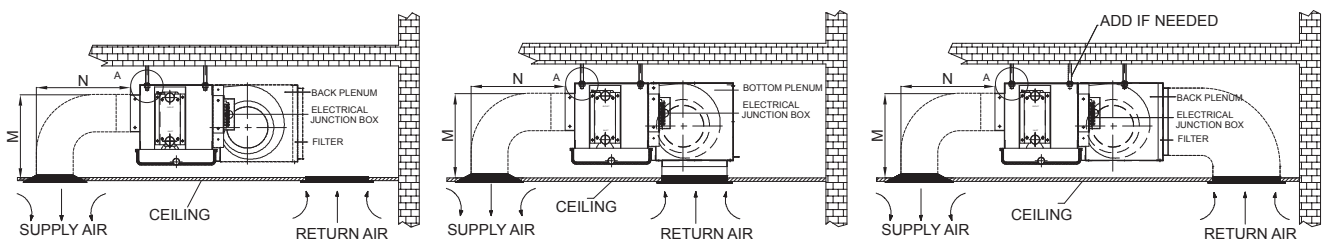

Fig.2



## NOTE:

Dimension M and N was determined by air duct design, air duct should be fire-proof, refer to concerned country national and local regulations.

Circulatory air pressure drop should be approximately equal to the External Static Pressure.

Fig.3 DETAIL A:

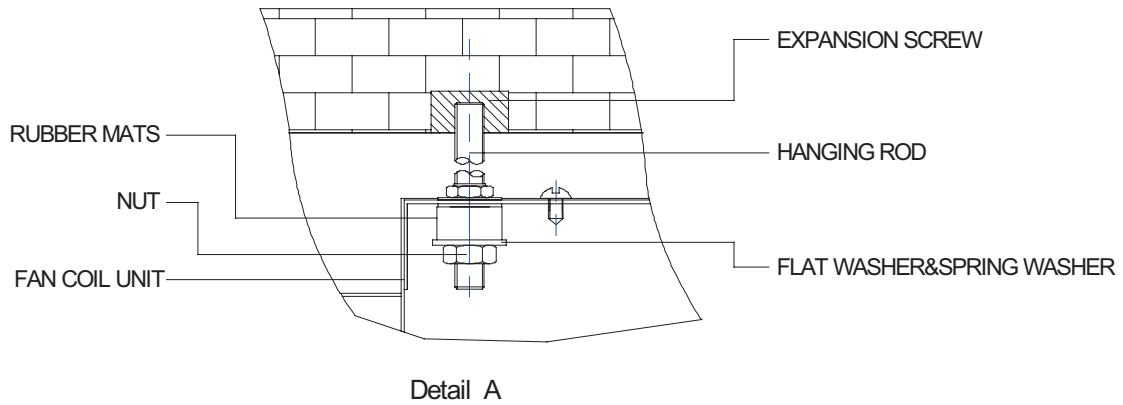

### INSULATION

The insulation design and materials should be complying with local and national codes and regulations. Chilled water pipes and all parts on the pipes should be insulated. It is also necessary to insulate the air duct.

### AIR DUCT CONNECTION

Circulatory air pressure drop should be within External Static Pressure. Galvanized steel air ducts are suitable. Make sure there is no leak of air. Air duct should be fire-proof, refer to concerned country national and local regulations.

### PIPE CONNECTION

Using suitable fittings as water pipe connections with reference to the outline and dimensions. The water inlet is on the bottom while outlet on top. The connection must be concealed with rubberized fabric to avoid leakage. Drain pipe can be PVC or steel. Water filter should be installed in the chiller water pump inlet and evaporator inlet pipes to prevent from block. Use flexible connector tubes to connect the water entering and leaving pipes of the unit. Seal the joint with tape after connection. Keep the wrench near the water entering and leaving pipe during pipeline connection. Fasten the joints slowly at a constant speed. The torque is 110 N•m (11.2 kgf•m) at most. When tools with long arm of force are used, properly set the torque. An excessive torque can deform or even damage the copper pipe and cause leakage. The pipeline connection is shown in the following figure.

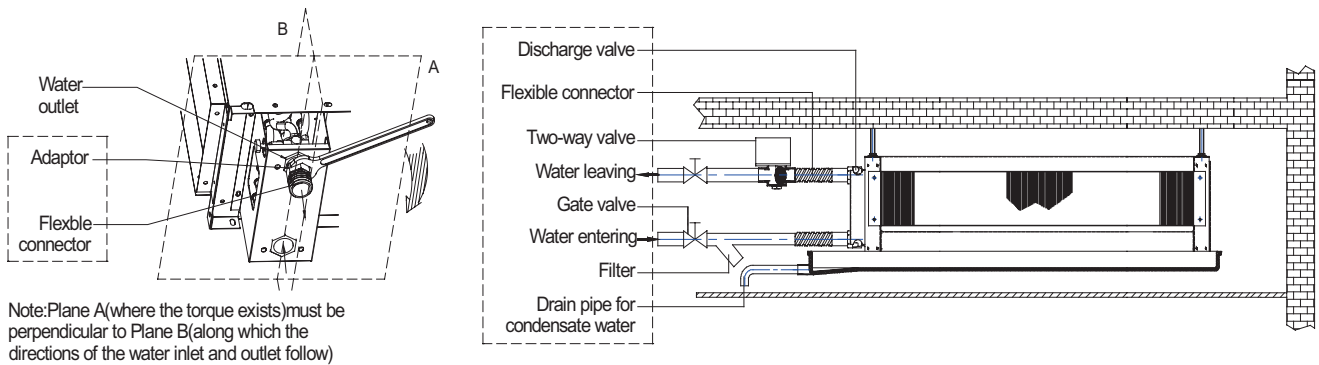

Note: Plane A (where the torque exists) must be perpendicular to Plane B (along which the directions of the water inlet and outlet follow)

Remarks: Customers must prepare devices marked in the dashed box

The suggested slope of the drain pipe is at least 1:50.

Preliminary softening treatment must be taken for water system, aimed to protecting plate exchanger from scaling. In addition, the unsoften water may be scaled on the pipeline, leading to increasing the water resistance, and the water flow and water pump will be impacted.

	Item	Base Value	Tendency	
			Corrosion	Scale Formation
Standard item	pH value (25°C)	6.5 ~ 8.0	○	○
	Conductivity (25°C)	μS/cm	< 800	○
	Cl <sup>-</sup>	mg(Cl <sup>-</sup> )/L	< 200	○
	SO <sup>2-</sup>	mg(SO <sup>2-</sup> )/L	< 200	○
	Acid consumption (pH=4.8)	mg(CaCO <sub>3</sub> )/L	< 100	○
	Full hardness	mg(CaCO <sub>3</sub> )/L	< 200	○
Reference item	Fe	mg(Fe)/L	< 1.0	○
	S <sup>2-</sup>	mg(S <sup>2-</sup> )/L	0	○
	NH <sup>+</sup>	mg(NH <sup>+</sup> )/L	< 1.0	○
	SO <sub>2</sub>	mg(SiO <sub>2</sub> )/L	< 50	○

**Note:** ○ indicates relevant factors that are inclined to corrosion or scale formation.

### WIRING

Wiring connection must be done according to the wiring diagram on the unit.

The unit must be **GROUND**ED well.

An appropriate strain relief device must be used to attach the power wires to the terminal box.

A 5/8" hole is designed on the terminal box for field installation of the strain relief device.

Field wiring must be complied with the national security regulations.

A main switch or other means for disconnection, having a contact separation in all poles, must be incorporated in the fixed wiring in accordance with the relevant local and national legislation.

Unit cannot be parallel connected for electric wiring, or it may cause motor burning.

When unit fan motor stops running and continuous chilled water supply for long may cause unit condensation.

Please install electric valve and thermostat to ensure properly working.

### OPERATING LIMITS

Items	OPERATING LIMITS
Water Circuit	
Maximum water-side pressure	1.6 MPa
Minimum entering water temperature	5°C (cooling) 70°C (heating)
Maximum entering water temperature	16~36°C(cooling) 10~30°C(heating) humidity(<90%)
Recommend operation range	
<b>Power supply</b>	
Operating voltage limits	± 10%
Operating frequency limits	Volt ± 1 Hz

## VALVE KIT

The valve kit is applied for 2-pipe system.

For unit coupled with valve kit, the drain pan should extend 200mm based on standard one.

Pay attention to the connecting direction (L/R) of valve kit when place order.

2-way valve kit can be applied for FWW-VC, FWW-C, FWW-F and FWW-DA series

3-way valve kit can be applied for FWW-VC, FWW-C, FWW-F series and FWW02~14DA model

### Parts

The kit consists of (refer structure figure 0 ~ figure 2):

- **2/3 way valve body** is made of brass, maximum working pressure 1.6MPa.
- **Electric actuator** has the following specifications:
  - Power supply: 220V±10%, 50Hz/60Hz (±2Hz)
  - Activation: ON/OFF
- **Hydraulic kit** for the installation of the valve on the heat exchanger, complete with 2 ball valves for adjusting the water flow and for closing the water circuit when perform maintenance to the unit.
- **Y-strainer** protects unit from impurity, increases the service life and insulating valves.

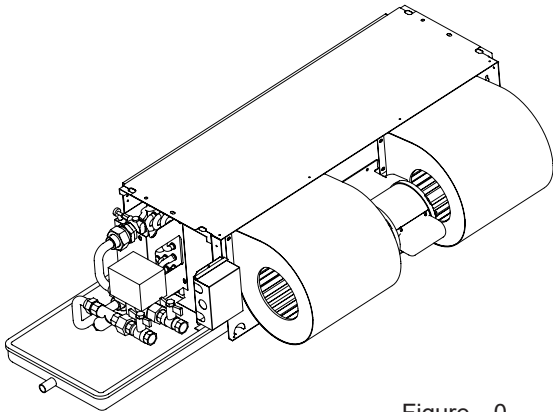

Figure 0

All parts of 2-way valve kit are indicated in the figure 1. ( For right pipe connection unit.)

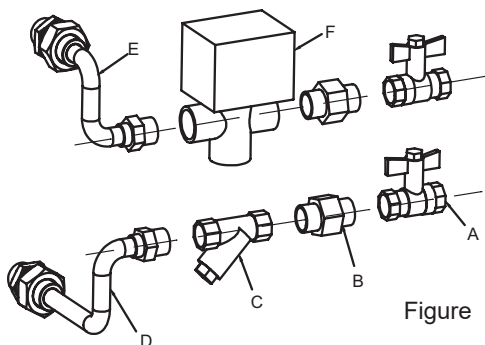

Figure 1

- A Ball valve
- B Brass connector
- C Y-strainer
- D Water inlet pipe
- E Water outlet pipe
- F 2-way valve

All parts of 3-way valve kit are indicated in the figure 2. ( For right pipe connection unit.)

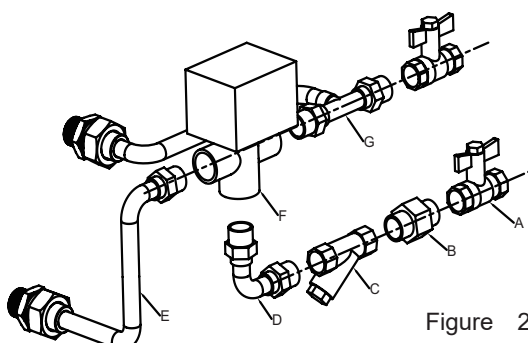

Figure 2

- A Ball valve
- B Brass connector
- C Y-strainer
- D Connector pipe
- E Water inlet pipe
- F 3-way valve
- G Water outlet pipe

## Installation

1. Install the 2-way valve kit as indicated in the pictures of figure 3. (For right pipe connection unit.) As shown as detail A, firstly take apart connector, then install ① to unit with necessary sealing material. Fix ② between ① and ③. At last tighten ③, make sure all of connectors are sealed.
2. Install the 3-way valve kit as indicated in the pictures of figure 4. (For right pipe connection unit.) Detail is as same as 2-way valve unit.
3. The insulation and pipe connection should refer to the details of unit installation.

⚠ The valve kit has been pre-assembled for easy installation.

- Where needed the connections are pre-coated with sealing material.
- The connections are not tightened for easy adjustment.
- After determining the final position of the valve kit, tighten all connections to obtain water tightness.

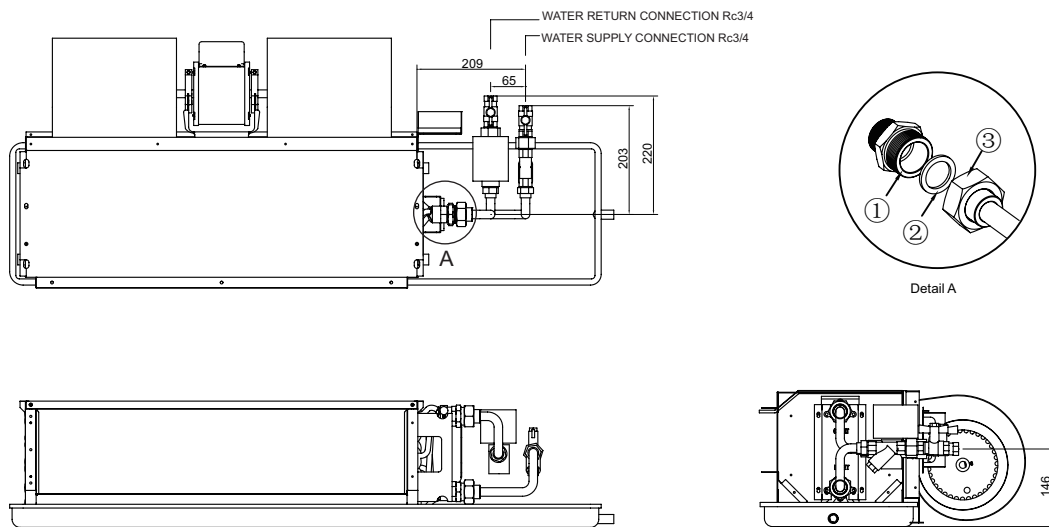

Figure 3 2-Way Valve

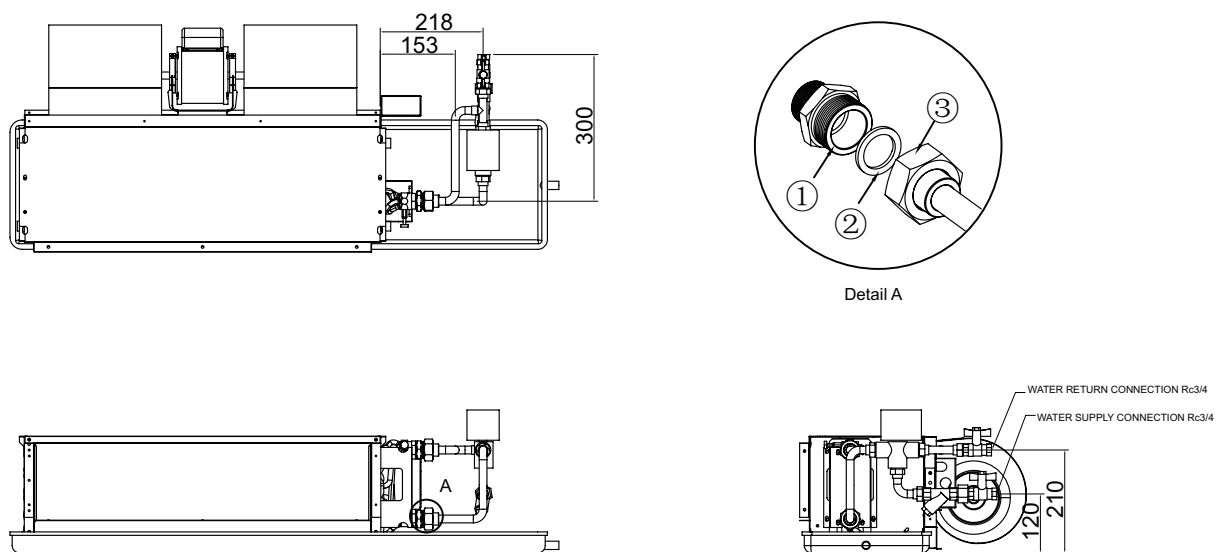

Figure 4 3-Way Valve



4. The flow resistance of the connecting valve/hydraulic kit assembly is obtained from the following formula:

$$\Delta P_w = (Q_w/100K_v)^2$$

$P_w$  is the flow resistance (Pa)

$Q_w$  is the water flow rate (m<sup>3</sup>/h)

$K_v$  is the flow rate identified in the table

Valve Model	DN	Connction Type	Valve Type	$K_v$	Shut-off Pressure Difference (MPa)
MC-FCV3335G	20	Rc3/4"	3-way Valve	3.4	0.18
MC-FCV2334G	20	Rc3/4"	2-way Valve	3.0	0.18

5. Refer to the wiring diagram of the appropriate controller. For connection with the DAIKIN controller, position the water temperature sensor into the appropriate position. Refer to the dedicated controller installation and operation manual.

## Guide Specifications for FWW Unit

### Unit Description

Factory-assembled, horizontal, galvanized casing, ceiling ducted fan coil unit is complete with water coil, fans, motors, drain pan, filters and all required wiring, with full access to internal components.

### Quality Assurance

Each coil is factory tested for leakage at 2.0MPa air pressure with coil submerged in water. Each unit and its moving components (fans and motors) are factory computer-tested and recorded after unit is complete and before it is packed.

### Component Specifications

#### 1. Casing:

Construction is galvanized steel, lined on the inside with PE thermal and acoustical insulation. Return air plenum is lined with PE foam and has a collar for return duct connection. Supply duct connection also has a collar. Removable bottom panel is provided for access to the fan/motor assembly.

#### 2. Coil:

Standard unit is equipped with a 3-rows, 4-rows or 3+1 rows coil for installation in a 2-pipe or 4-pipe system. Coil has seamless copper tubes, slit type fins hydrophilic aluminum bonded to the tubes by mechanical expansion. Each coil has a manual air vent and two water pipe connections with a maximum working pressure of 1.6MPa.

#### 3. Fan:

Direct-driven centrifugal fan wheel has forward-curved blades which are statically and dynamically balanced.

The fan housing and blades are constructed of high quality hot-galvanized steel.

#### 4. Motor:

Fan motor is 3-speed, permanent split-capacitor with ball type bearing and build-in automatic reset thermal overload protection.

#### 5. Drain Pan

The drain pan plate body is constructed of cold-rolled steel by way of integral cupping. Both its sides are sprayed with plastic coating. And its outer wall is lined with PE foam and high quality adhesive by way of integral adhering and pressing. It extends under the full length and width of the coils and is pitched for positive drainage with features of high anti-corrosion, anti-condensation and high fire reluctance.

#### 6. Filter

Filter is with washable type nylon media in 8mm thickness aluminum frame.



**Warning**



- Daikin Industries, Ltd.'s products are manufactured for export to numerous countries throughout the world. Daikin Industries, Ltd. does not have control over which products are exported to and used in a particular country. Prior to purchase, please therefore confirm with your local authorized importer, distributor and/or retailer whether this product conforms to the applicable standards, and is suitable for use, in the region where the product will be used. This statement does not purport to exclude, restrict or modify the application of any local legislation.
- Ask a qualified installer or contractor to install this product. Do not try to install the product yourself. Improper installation can result in water or refrigerant leakage, electrical shock, fire or explosion.
- Use only those parts and accessories supplied or specified by Daikin. Ask a qualified installer or contractor to install those parts and accessories. Use of unauthorized parts and accessories or improper installation of parts and accessories can result in water or refrigerant leakage, electrical shock, fire or explosion.
- Read the User's Manual carefully before using this product. The User's Manual provides important safety instructions and warnings. Be sure to follow these instructions and warnings.

If you have any enquiries, please contact your local importer, distributor and/or retailer.



The air conditioners manufactured by Daikin Industries have received **ISO 9001 series** certification for quality assurance.

Certificate Number. FM 661837



The airconditioning factories of Daikin Industries have received environmental management system standard **ISO 14001** certification.

Certificate Number. EMS80362

### Cautions on product corrosion

1. The units should not be installed in areas where corrosive gases, such as acid gas or alkaline gas, are produced.
2. If the unit is to be installed close to the sea shore, direct exposure to the sea breeze should be avoided. If you need to install the unit close to the sea shore, contact your local distributor.

## DAIKIN MIDDLE EAST & AFRICA FZE

P.O. Box 18674, Jebel Ali Free Zone, Dubai, UAE Tel: +971 (0) 4 815 9300, Fax: +971 (0) 4 815 9311

Email: [info@daikinmea.com](mailto:info@daikinmea.com) Web: [www.daikinmea.com](http://www.daikinmea.com)



Daikin Middle East and Africa