



Every step of the way, Urethane Supply Company has what you need to repair and refinish plastics.



HOT AIR & NITROGEN WELDING SET-UP AND USE GUIDE

A complete guide to setting up your new hot air & nitrogen welding equipment and using it to make the fastest, strongest, and most cost-effective repairs to plastic bumper covers and other parts.

YOU WILL SUCCEED

Introduction

Thank you for your purchase of Urethane Supply Company's hot air welding system. This system allows you to repair plastic parts more quickly and cost-effectively than you can with any other system. Using our nitrogen welding process, your repairs will be of the highest quality—maximizing strength and minimizing comebacks. By investing in this equipment, you have demonstrated a commitment to quality and productivity that will give your shop a leg up on the competition. With the nitrogen welding setup, you will...

- Make repairs faster, which will make you more money on flat rate work
- Make repairs with greater strength so you won't worry about comebacks
- Make repairs that can't be done by your competitors, which will drive more work to your shop
- Demonstrate to your insurance partners that you are committed to the latest technology

This booklet is intended to teach the basics of using the hot air welder and to demonstrate some of the unique repairs that can be done with it. There are always new innovations in products and techniques—not everything can be captured in this booklet. If you are interested in learning the latest techniques, we offer quarterly training seminars at our factory. We also offer on-site consulting and training. Please call us at 800-633-3047 for details.

6053 EZ-Weld Hot Air Welder Setup and Use

1.) Screw in a ¼" male pipe thread fitting into the air inlet in the back panel of the welder that fits the quick-disconnect chucks used in your shop. Attach an air hose to this fitting. Supplied air should be clean—free from water and oil. Water or oil in the air will cause premature failure of the heating element. **Urethane Supply Company DOES NOT warrant the heating elements or any damage resulting from overheating of the elements or from damage caused by water or oil in the air line.**

2.) Turn on the air flow. DO NOT turn on or plug in the power cord until you have a steady flow of air coming from the welder's tip. The heating element must ALWAYS have adequate air flow to prevent it from burning out. Air flow should be set quite low--you're more likely to distort or melt through plastic if the air flow is set high.

3.) Plug in the power cord. Power is turned on and off by pressing the knob. The knob is rotated to the desired temperature setting. Within a few seconds, you should begin to feel some heat and an increased flow of air out of the welder. This is your indication that the welder is working properly. Allow 4-5 minutes for the welder to attain operating temperature. NOTE: The temperature control knob does not have a warning light. Because the light would dim with the rheostat, the element could burn out even if the light were too dim to be visible. Because of this fact, we felt that a light would not help to prevent element failure.

4.) Weld the plastic per instructions listed in this booklet. Again, airflow should be set quite low to prevent overheating, distorting, or blowing holes through the plastic.

5.) When you are finished welding and want to shut the welder off, press the temperature control knob again to turn off the power to the heating element. Let the air continue to flow until the air coming out the tip is at room temperature and you can hold the metal barrel with your bare hand. Proper cool-down of the heating element is the most important aspect of long element life. It's simple—shut the power off first then let the air flow until it is cold!

6053N2 Nitrogen –Air Controller Setup and Use

Making your plastic welds with nitrogen (or an inert gas like argon) will greatly increase the strength of your repairs. This is because air is about 23% oxygen. The oxygen oxidizes, or burns, the melted plastic. This burned plastic causes contamination in the weld which reduces its strength. The "shielding gas" has the same effect on plastic welds as it does on metal welds.

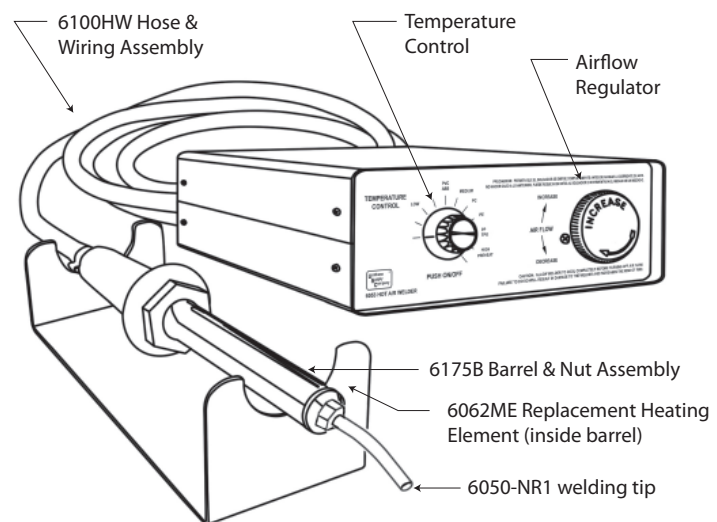

6053 EZ-Weld 2.0 Hot Air Welder - Controls & Replacement Parts

The 6053N2 Nitrogen-Air Controller allows both air and nitrogen to be supplied to your 6053 hot air welder. You can switch the gas to nitrogen when making your welds to achieve the optimum strength. When you're not welding, you can switch the gas to air to save your bottled nitrogen.

1.) To setup your Nitrogen-Air Controller, make a short air hose to connect the outlet of the controller to the inlet of the 6053 welder. Then pipe nitrogen to one side of the inlet and air to the other side. You can get a regulator and nitrogen tank from your local welding supply store. Set the Nitrogen-Air Controller in a convenient place on your workstation that's easily accessed by your technician.

2.) To use the Nitrogen-Air Controller, press down the gold knob in the middle of the box to select "air." Adjust the regulator on the box to set the inlet air pressure between 40-50 psi. Verify that you have airflow out of the welder tip. If you do not, check that the regulator on the welder is open.

3.) Open the regulator on the nitrogen tank and set the outlet pressure to between 50-100 psi. Then on the Nitrogen-Air Controller, adjust the regulator on the nitrogen side with the knob pulled up to "nitrogen" to the same pressure as on the air side, between 40-50 psi. The valve is designed to have balanced pressure on both sides. You'll notice a slight dip in the pressure reading on the side that's selected--adjust the pressure as it flows to match.

4.) Once you have the pressure of the air and nitrogen equalized, pull the gold knob up and verify that you have flow through the welder tip. With the pressures balanced, you should not sense any difference in flow from the tip of the welder except for a slight interruption of the flow as the knob is moved up and down.

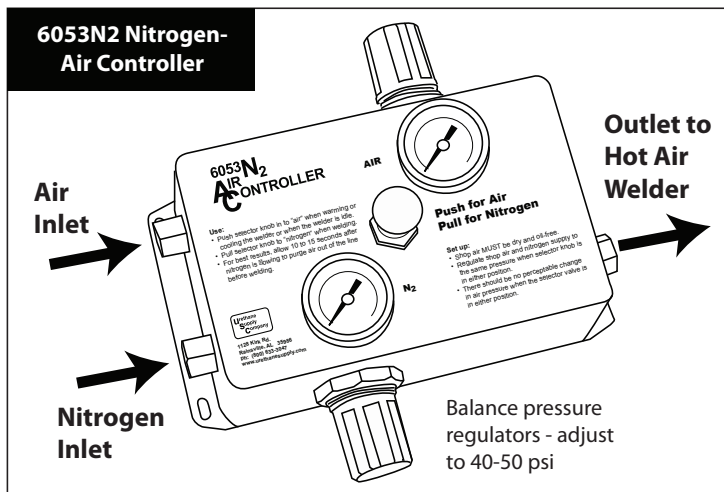
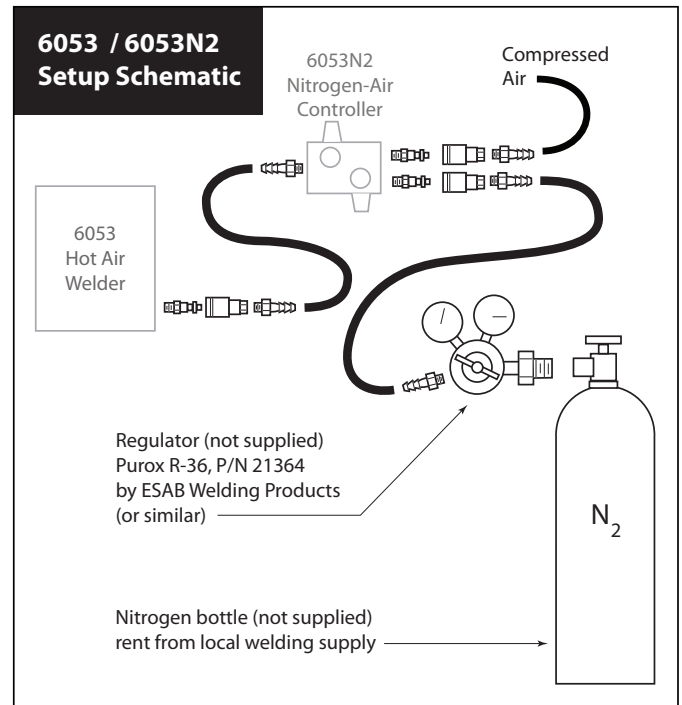

5.) After you've verified gas flow from both the air and nitrogen sides, you can then turn on the power on the 6053 EZ-Weld 2.0 hot air welder and use as described in the previous section. Select "air" as the welder warms up so you don't waste the nitrogen. Make it a habit to switch the flow to nitrogen before you begin welding and back to air when you're finished with your weld. This will minimize the use of your nitrogen gas and assure adequate gas flow to keep from burning out the heating element.

NOTE: One important feature of the design on the 6053N2 Nitrogen-Air Controller is that if the nitrogen bottle runs out of gas while the controller is set on "nitrogen", the air will back-flow through the element, helping to prolong element life. The flow will be reduced, so it's not recommended to run like this for any

amount of time. If you notice that the nitrogen bottle is empty, always push the gold knob down to put the welder back on air while you replenish the nitrogen supply.

Plastic Identification – Can I Use the Hot Air Welder?

The hot air welder can be used on virtually any thermoplastic (melttable plastic). You can't use it on thermoset plastics like polyurethane (PUR) or fiberglass. Use our Mini-Weld airless plastic welder to repair thermoset polyurethane.

About 99% of automotive bumper covers today are made of polypropylene (PP) blends. They are usually black or dark gray on the backside. If you can find an ID symbol on the backside, it will usually say PP, PP+EPDM, TEO, or TPO.

| Type of plastic | Hot air weldable? |
|--|-------------------|
| PP, PP/EPDM, TEO, TPO, TSOP, PE, ABS, PA, PC | YES |
| PUR, SMC, UP, fiberglass | NO |







There are still some late model bumper covers made of PUR. At the time of this writing, these would include Ford Crown Victoria, Chrysler 300 front, Dodge Charger front, and Corvette. These are usually yellow or light gray on the backside. Don't use the hot air welder on these bumpers.

If you identify the bumper as being a PP blend, the hot air welder can be used with any of our PP or TPO welding rods. At the right is a table showing the different dimensions of our plastic rods and strips. More are being developed all the time, so please check our website for the latest information.

If you are welding something other than a bumper cover, identify the type of plastic used and select the rod to match. For example, radiator overflow bottles and ATV fenders are made of polyethylene (PE). Weld these with our polyethylene welding rod. See the table below for a short list of different types of plastics, typical applications, and the proper welding rod for each. If you have any technical questions, please call us at 800-633-3047 for assistance.

Common Thermoplastics and Typical Applications

| Plastic Symbol & Type | Typical Applications | Welding Rod |
|--|---|--------------------------------------|
| ABS | instrument panels, grilles, trim moldings, street bike fairings | ABS (R3) |
| PA - Polyamide, Nylon | radiator tanks, mirrors, door handles, plastic engine parts | PA (R6) |
| PC - Polycarbonate | headlight lenses and housings | PC (R7) |
| PC + ABS blend | door skins, street bike fairings, instrument panels | PC (R7) or ABS (R3) |
| PC + PBT blend (Xenoy) | bumper covers (older Ford, M-B, BMW) | PC (R7) |
| PE - Polyethylene | over-flow tanks, windshield washer bottles, ATV & dirt bike fenders, water storage tanks, kayaks & canoes | PE (R4, R18, R19, R20, R21) |
| PP, PP/EPDM, TPO, TEO, TSOP - Polypropylene Blends | bumper covers, side cladding & trim, filler panels, under-hood parts, interior parts, snowmobile cowls | PP (R2, R5, R13, R14, R15, R16, R17) |
| PPO + PA blend (Noryl GTX) | fenders (GM), exterior trim | PA (R6) |
| PVC - Polyvinyl Chloride | pipe, siding, window frames, gutters, trim | PVC (R9) |

| Types of plastic | Rod Profile |
|-------------------------------|---|
| PP, ABS, PE, PA, PC, PVC, TPO |  1/8" dia. |
| PP, PE |  3/16" dia. |
| PP, PE |  7/16" x 1/16" |
| PP, PE |  3/4" x 1/16" |
| PP, PE |  9/16" x 1/8" |
| PP |  Triangular |

Basic hot air welding process

Welding with hot air involves the coordination of both hands, one controlling the torch and the other feeding the rod. When you weld, you just want to melt the bottom surface of the rod and the top of the bumper. You don't "puddle" the rod like you do in metal welding. This makes for a stronger repair because it leaves the basic structure of the rod intact. When you're making your weld, there will be a small bead of melted plastic at the junction point between the rod and bumper as you make your pass. Remember the four important factors for plastic welding: "T.A.P.S.", an acronym for Temperature, Angle, Pressure, and Speed.

- For **temperature**, set the temperature on the hot air welder's dial to the proper setting. For example, the PP/TPO setting will generate an air flow of about 550°-600°F. This can be adjusted up or down for various thicknesses of plastic, but this is a good starting point.
- An **angle** of 45° between the torch and the bumper is optimum. Aim the stream of hot air a little in front of the rod; for thick rod like the R16, focus the heat back toward the rod.
- Put as much downward **pressure** on the rod as possible to help the rod fuse with the bumper. Keep a steady downward pressure on the rod and keep the rod moving slowly. Don't overheat the rod and let it fold over backwards.
- The **speed** of your weld should be about 4 to 6 inches per minute. With thin rod like the R13, it's difficult to go this slow. With thick rod like the R16, it may go even slower. The important thing is to move steadily while keeping proper downward pressure on the rod and a small bead of melted plastic in front of the rod.

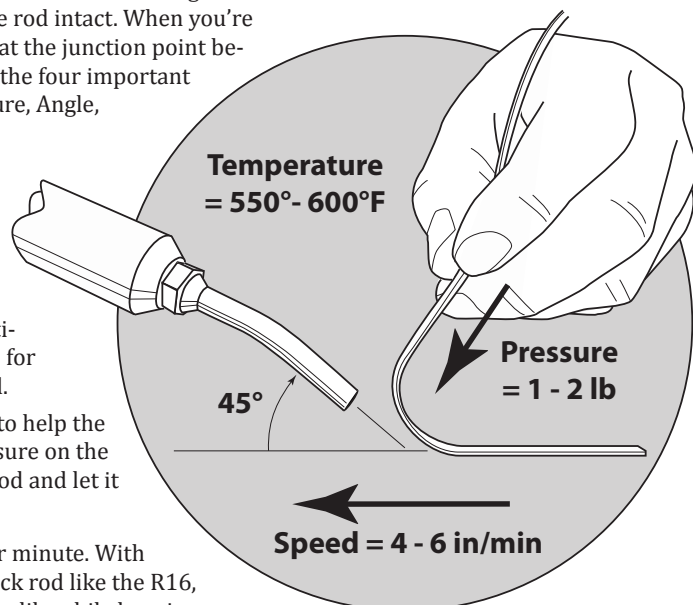

Repairing a cracked bumper

Let's assume you have a cracked PP/TPO bumper. This section will take you through the whole process—cleaning, prepping, and welding. This describes the basic repair technique that can be adapted to other specialty repairs on tabs and mounting holes.

- a. **Clean the bumper before you grind it.** Before you touch the bumper with sandpaper or a die grinder, make sure it's clean first. It's difficult enough to get adhesion to TPO—don't make things more difficult by not cleaning it first. First, clean the entire bumper by washing with 1047 Scuff Magic soap using a red scuff pad as a "sponge" to both spread the soap and scuff the plastic. This will put small sand-scratches into the bumper to help further improve adhesion. Rinse all the soap off and let the bumper dry. Once it's dry, clean the bumper with Urethane Supply 1000 Super Clean plastic cleaner or low VOC alternative. This will remove all solvent-soluble contaminants like silicone, wax, mold release agent, etc. Spray on in a heavy, wet coat, let it sit on the surface for a few seconds, then wipe dry with a clean paper towel before it evaporates. Don't just soak a rag and wipe it around—that only moves the contamination around on the surface and does not remove it.
- b. **Align the Outer (Cosmetic) surface.** Often the plastic has been stretched or distorted in the damaged area. Before you weld, get the crack back as closely as possible. If the plastic is dented or stretched, heat with a heat gun and push the plastic back into position. Once the plastic pieces are lined up, use Urethane Supply's 6481-1 or 6485 aluminium tape on the outer (cosmetic) surface. It's best to line up the outer surface to minimize the need for filler and weld the backside of the crack first.
- c. **Prep the backside of the crack.** If there's any paint over-spray on the backside, remove it first by sanding with 80 or 180 grit sandpaper. Also lightly sand the area the welding rod will be applied to with 80-180 grit paper. Normally, there is no need to v-groove the backside unless you want to sand the repair flush for some reason. Welding flat on the back with a deeper v-groove on the front will help create a stronger repair.
- d. **Weld the backside of the crack.** For maximum strength, it is best to use our R16 or R14 rod on the backside. Both of these rods offer more surface area and/or thicker stock for greater strength. To do the weld, start by focusing the heat of the welder about 1/2" past the crack on a solid part of the bumper. The plastic will start to turn glossy. At this point, stab the end of the ribbon rod down into the plastic and start bending it toward the welder.
- e. **Prep the front side for welding.** After the backside is cool, peel the aluminum tape off the front side. Using a 1/2" ball cutter in a die grinder, grind out a v-groove in the plastic about 1/16" deep and 1/2" wide. You should also put some sanding scratches in the plastic by hitting it with a 50 grit Roloc or 80 grit in a DA. Blow dust free.

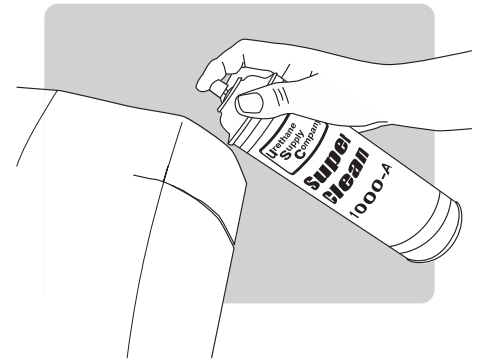

Step A - Cleaning the plastic with 1000-A Super Clean plastic cleaner

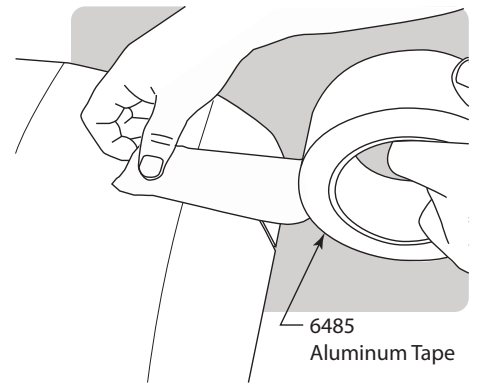

Step B - Aligning the cosmetic outer surface with aluminum tape

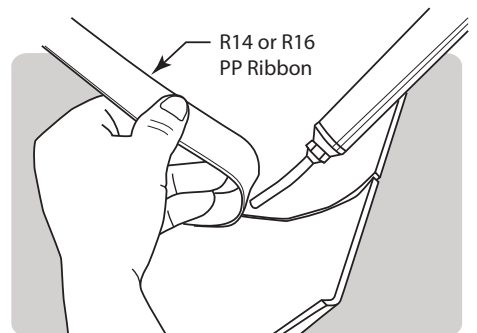

Step D - Welding the backside of the crack with PP ribbon rod

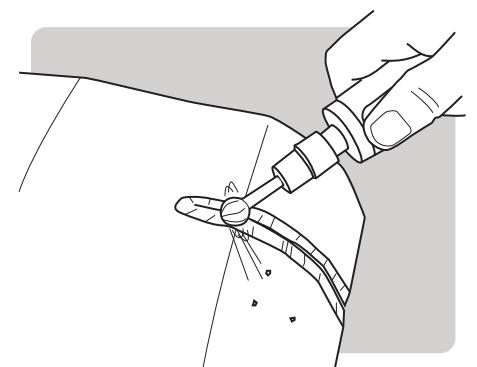

Step E - Preparing the front side for welding by grinding a v-groove

- f. **Weld the front side of the crack.** On the front, it's usually best to use the narrow, thin R13 rod. This will tuck down into the v-groove and retain most of its strength even after it's been sanded flush. Use the same process as on the backside to weld it. However, the R13 will melt and bend much more easily since it's thinner. It's best to focus the heat from the welder a little farther in front of the point where the rod meets the bumper to keep the rod from becoming too weak. You need to apply about a pound of downward pressure on the rod as you do your weld to make sure the rod fuses properly with the bumper.
- g. **Finishing the weld.** Once the weld is completely cool, sand with 50-80 grit paper in a grinder or DA. Be careful not to sand too fast; this will just melt and smear the plastic. It's best to use a sharp, new piece of paper and slow the sander down a bit to keep the plastic from melting. Sometimes the repair may be finished out and feathered with the welding rod, but most often you're going to need some filler to fill in the low spots. Please see our "Book of Plastic Repair" for more information on how to apply filler on plastic parts.

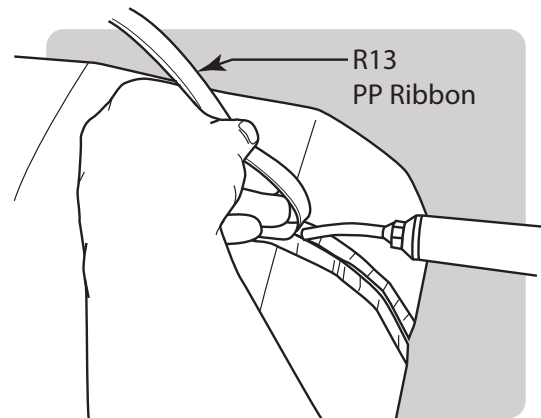

Step F - Welding the front side of the crack with R13 PP ribbon

Welding a broken bumper slot

Because of the strength provided by the nitrogen welding system, you can make strong repairs even when you don't have a lot of surface area to weld to. A perfect example is the slots on the edge of the bumper where the bumper snaps into the quarter panel, like on a Honda bumper. These often seem to break out when the bumper is removed. There's not enough surface area to make a good repair with either a two-part system or with the FiberFlex. Here's how you fix a torn-out bumper slot.

- a. **Clean the plastic first.** Do this every time BEFORE you touch it with sandpaper. Clean the plastic with soap and water first, then with 1000 Super Clean plastic cleaner.
- b. **Taper the edges with sandpaper.** Using 50 to 80 grit sandpaper, remove paint from the area to be welded and taper the ends down to a point on both sides. This will give you enough surface area to stick to when you finish the repair.
- c. **Apply tape to support rod during weld.** Use the 6481-1 or 6485 aluminum body tape underneath the hole to support the melted plastic welding rod. You can also clamp a strip of sheet metal or wood along the edge if that works better. Make sure the edge of the support is at the edge of the plastic so it doesn't interfere with the clamp and leave room between the clamps to use the hand seamer as described in Step F.

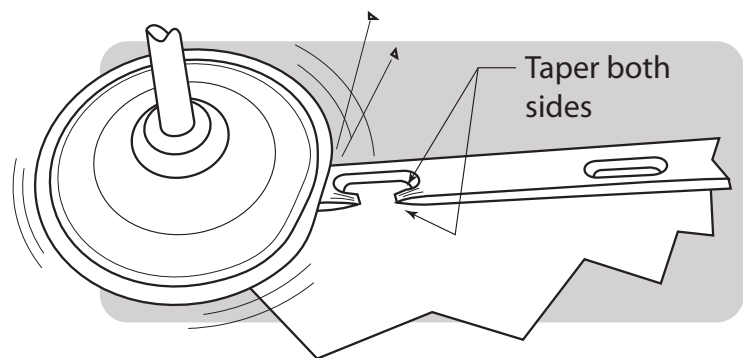

Step B - Tapering the edges of the slot to be repaired with sandpaper. Taper both sides down so the rod has surface area to stick to once sanded.

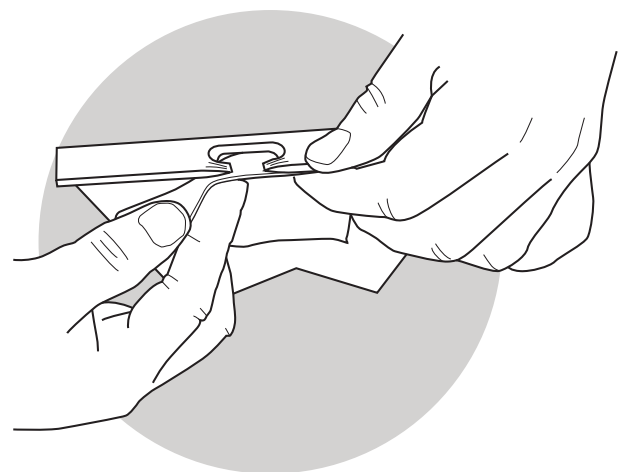

Step C - Applying aluminum tape to support the melted welding rod. You can also clamp a wooden stick underneath to provide extra support.

- d. **Narrow the welding rod to width of bar.** The R13 rod is probably too wide, so cut it down roughly to the width of the bar using scissors or a razor knife. This will help prevent obscuring the slot dimensions.
- e. **Weld across gap with ribbon.** Starting on one side, preheat the bumper about 1/2 inch past the slot using the nitrogen until it turns a bit glossy. Stab the end of the rod down into the plastic and start laying it down as shown. Span across the gap and pick up the process on the other side. Chop off the rod on the other side with the hot welder tip itself. Check our website for videos on how to do this.
- f. **Heat until rod turns clear and mash with hand seamer.** If you're using our white PP ribbon, you can see that it turns clear when it gets to the proper melting temperature. Heat up the ribbon you just laid down with the nitrogen welder until it all turns clear. (If you're using the black rod, heat it until it all turns glossy black). Immediately use our 6145 hand seamer to firmly mash the melted ribbon down into the plastic. This also aligns the repaired section with the rest of the bumper.
- g. **Restore slot dimensions.** Let the weld cool and remove the tape or metal support. Then using a Dremel tool (using the 6120 or 6123 straight burrs), airless plastic welder, or knife, restore the original slot dimensions. This is easier to do when using the white rod as you can see the underlying plastic.
- h. **Weld opposite side.** Repeat the welding process on the opposite side. Usually the tape or metal support is not needed, but it can be helpful. After welding, mash the repaired area flat and straight again using the hand seamer.
- i. **Restore slot dimensions and finish repair.** After letting the weld cool, restore the final dimensions of the slot and bumper edge using a Dremel tool, airless welder, or knife. Finish sand the outer surface with 180 then 320 grit paper to prepare it for paint.

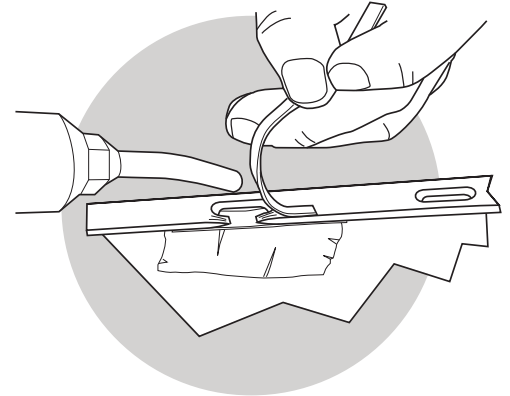

Step E - Welding across the gap with R13 PP rod narrowed to the proper width.

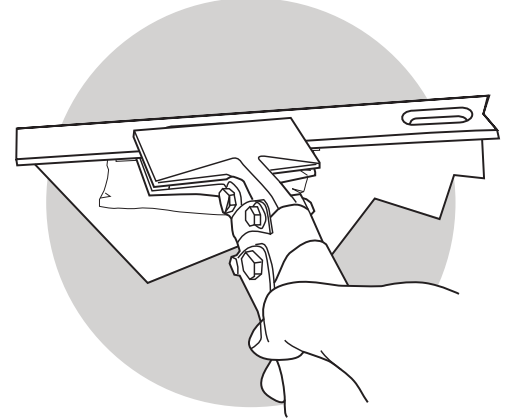

Step F - Mashing the hot plastic flat and impressing it into the bumper with the 6145 hand seamer

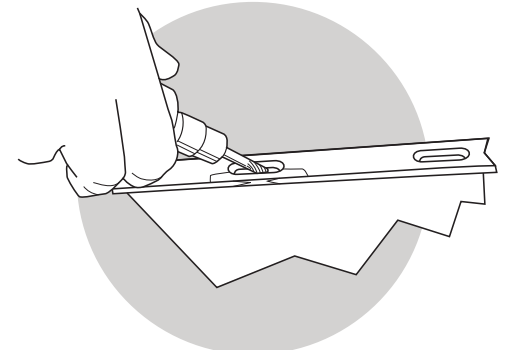

Step I - Restoring slot dimensions with a die grinder and finishing the repair

Recreating a tab with a "living hinge"

Many times you'll see bumpers that have a flexible tab, usually at the bottom of the bumper. These tabs have a "living hinge", which is a thin line in the plastic where it naturally wants to flex. These living hinges are very weak and are easy to tear. You can't repair it at the hinge line because it won't be flexible there anymore. To do this, you need to recreate the tab using our polypropylene sheet using the following method.

- a. **Trace out the tab in the polypropylene sheet.** If you have the old tab, lay it down on the 5010 polypropylene sheet and trace the edges and any holes with a Sharpie. Put a dotted line where the hinge line is supposed to be. Then create a notch back into the bumper about 1/2" deep and extend the tab about 1/2" on each

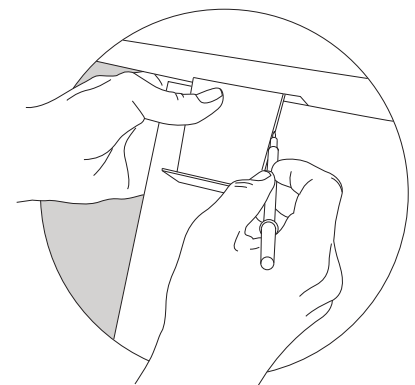

Step A - Tracing out the shape of the tab on the 5010 PP sheet

side of the tab. Cut the tab out of the PP sheet with a jigsaw, and drill out the mounting hole.

- b. **Create hinge line.** To create the hinge line, put the tab in a vise and fold it back and forth several times along the dotted line you drew on the tab. Take it out of the vise, then fold it over double a few times to make it more limber. This is flexible and much stronger than the original bumper's hinge. If there's a hook or fold in the tab, you can create it by folding it in the vise one time.
- c. **Notch back the bumper.** Place the new tab in position on the bumper and mark the cut line on the bumper with a Sharpie. Cut out the notch with a jigsaw.
- d. **Prep the bumper** by removing paint and applying sanding scratches the bumper on the backside.
- e. **Tape the tab in position** using 6481-1 or 6485 aluminum tape on the outer surface.
- f. **Weld the backside of the tab** using R14 or R13 rod. The R14 is much wider and will make a stronger weld. Start by focusing the stream of hot nitrogen about 1/2" beyond the tab until the bumper turns glossy. Stab the rod down and start making your pass using the same technique as described earlier.
- g. **Prep the outer surface** by grinding a shallow v-groove about 3/8" wide along the seam. Feather back paint and put down some sand scratches with 80 grit in a DA. Blow dust free.
- h. **Weld the front side of the bumper** with R13 rod. Lay one strip down along the long seam, then weld each end and wrap the welding rod around the edge. If you have an airless welder, you can melt and burnish everything down and make it easier to sand flush.
- i. **Let cool and finish the repair** by sanding smooth with 80 grit in a DA. Use filler if necessary to fill out any low spots, then sand with 180 and 320 grit to prepare for primer.

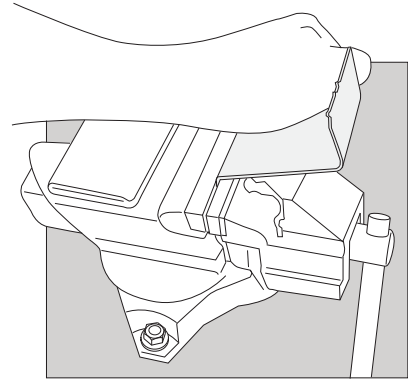

Step B - Create hinge line by bending back-and-forth in a vise

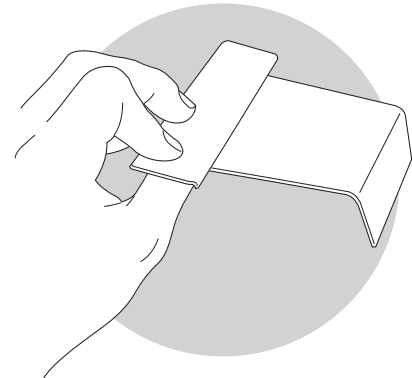

Step B - Create corners by bending once in the vise

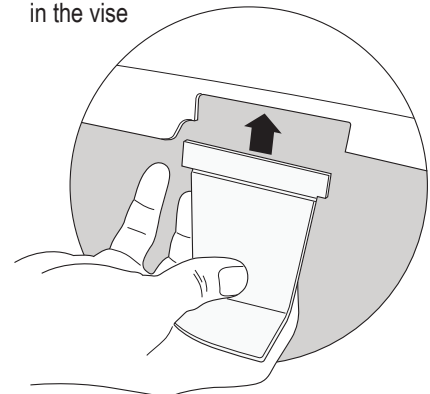

Step C - Notch back into the bumper to mount new tab

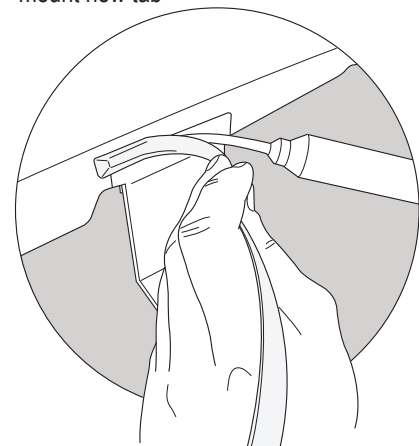

Step F - Weld the tab into place using the R13 or R14 rod

Visit www.urethanesupply.com for videos and other instructional resources. Check out our **YouTube** channel and become a fan on **Facebook** for periodic plastic repair tips.

We are committed to providing the most complete information on plastic repair and refinishing in the industry. Call **800-633-3047** for technical support, Monday through Friday 7:00am - 4:00pm Central.

Urethane Supply Company
1128 Kirk Rd, Rainsville, AL 35986 USA
phone: 256-638-4103 fax: 256-638-8490

