

1 How is heat transferred?

Ideas you need from KS3

How heat is transferred

Heat (thermal energy) always moves from hot places to cold places. This is called heat transfer. Sometimes you want to make it easy for heat to go from one place to another. Sometimes you want to keep heat in one place. So you need to know how heat travels.

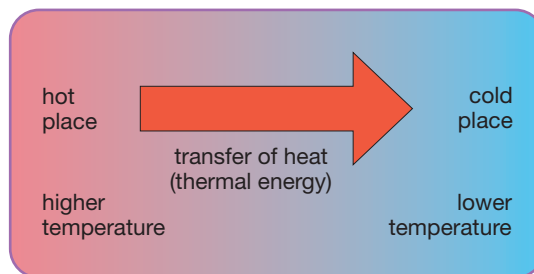

We often use the word 'heat' to mean the same thing as 'thermal energy'.

Radiation

When you stand near to a roaring bonfire, you can feel the heat from the bonfire falling on your face.

This happens because hot objects transfer heat by sending out rays. This method of energy transfer is called radiation.

- 1 What substance is required for heat transfer by radiation?

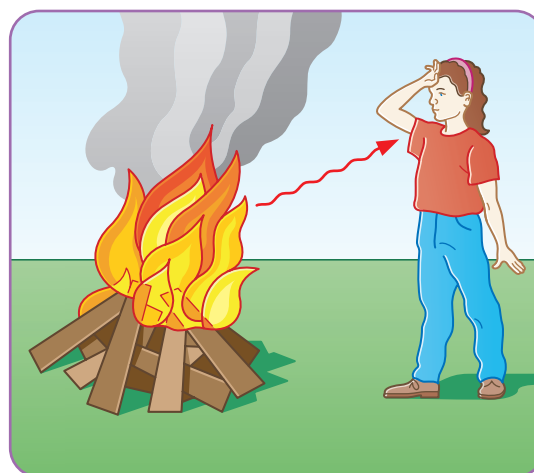

Thermal energy is transferred from the fire to your face by radiation. No substance (solid, liquid or gas) is needed, so the radiation can travel through empty space.

Conduction

If you put a solid between somewhere hot and somewhere cold, heat has to travel through the solid. This is called conduction. There has to be a substance there for conduction to happen.

Heat passes easily through some solids, for example metals. We call these conductors. Other solids conduct heat badly, and we call these insulators.

- 2 Look at the diagrams.

Copy and complete the table.

	Conductor or insulator?	Reason
bottom of pan		It will help transfer heat from the _____ to the _____.
table mat		It will cut down heat transfer from the _____ to the _____ surface.

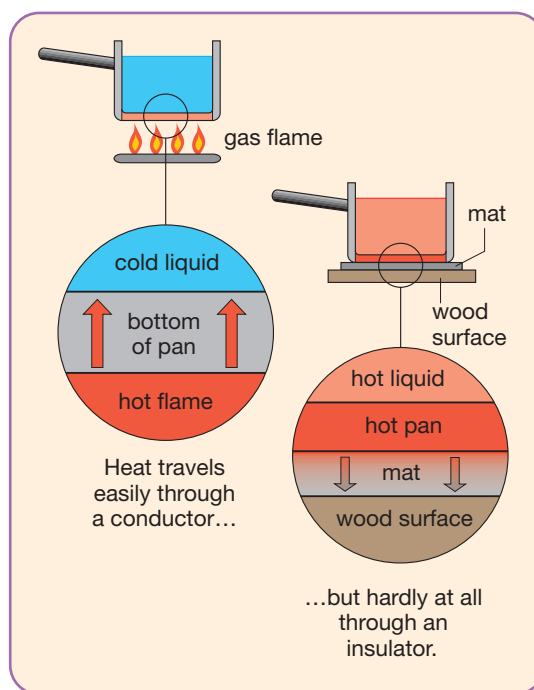

Convection in liquids

The water in a kettle is a liquid. Liquids can flow.

The heating element in an electric kettle is at the bottom, but it still heats up all the water in the kettle.

The diagrams show how it does this.

- 3** Draw one large diagram of the kettle.
 Add arrows to show how hot water rises and cold water falls.
 Label them or colour them in.
 Use red for hot and blue for cold.

Each time the water moves around the kettle it gets a little bit hotter.

Hot liquids move and carry heat with them. This is called convection.

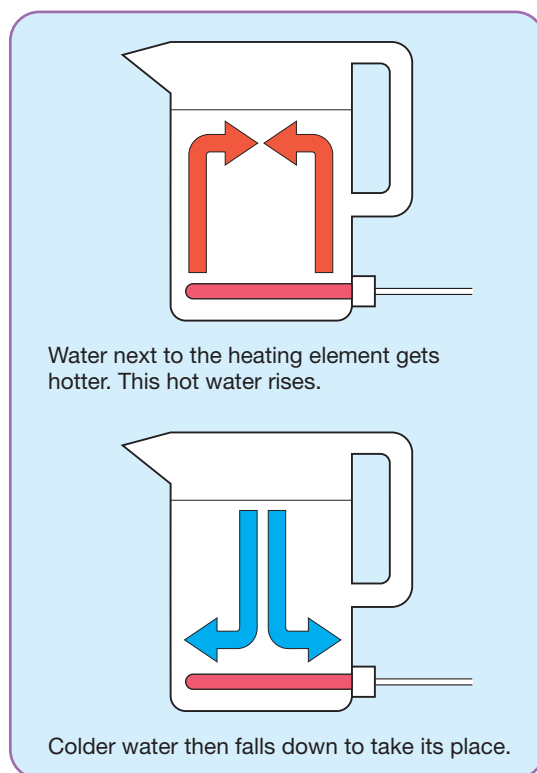

Convection in gases

The air in a room is a gas. Gases can also flow. Heaters are usually near the floor, but the whole of the room gets heated.

The diagrams show how heaters do this.

- 4** Draw one large diagram of the room and heater.
 Draw arrows to show the hot air rising and the cold air falling.
 Label or colour the arrows.

Hot gases, like hot liquids, move around and transfer heat by convection as they do so.

Convection only happens in liquids and gases.

It needs a substance that can flow.

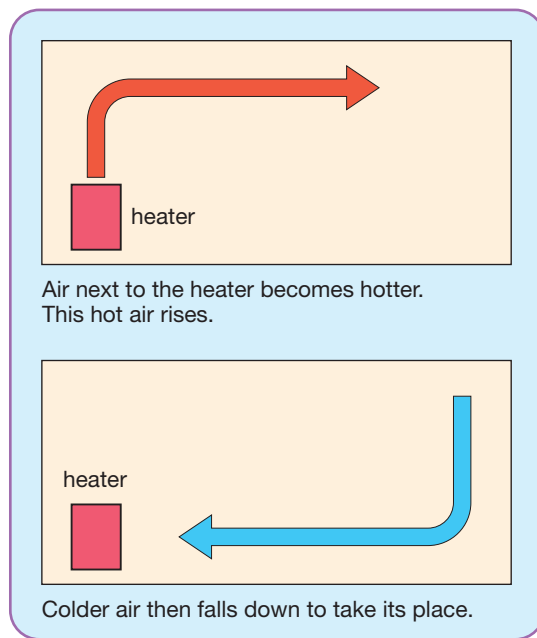

1 How is heat transferred?

1 Thermal radiation

All objects give out energy as **thermal** radiation. This energy travels as infra-red rays. You can't see **infra-red** rays. You can feel infra-red rays from a hot object when they raise the temperature of your skin.

- 1 Look at the diagrams. Then copy and complete the following sentences.

All objects give out _____ radiation.
 The _____ something is, the more radiation it gives out.
 If anything gets hot enough, it gives out _____ rays as well as infra-red rays.

- 2 Why are the horse's eyes, nostrils and mouth the brightest parts on the infra-red image?

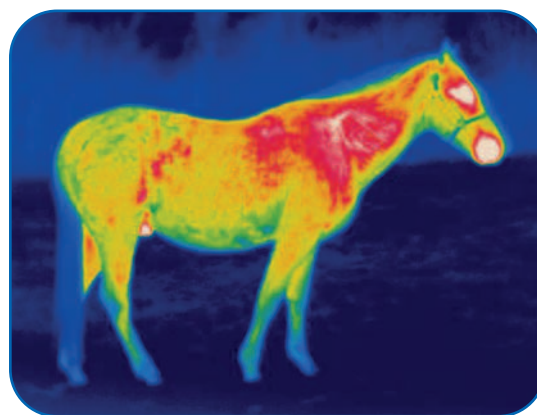
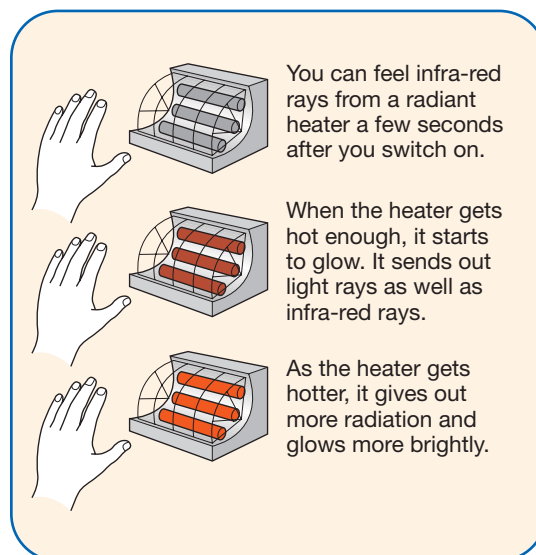

A wildlife photographer uses an infra-red camera to film animals at night. An infra-red camera shows that all objects give out infra-red rays. Hotter objects give out more infra-red rays than cooler ones. These appear brighter on the image.

Energy from the Sun

There is empty **space** between the Sun and us. Because there is no substance to travel through, heat from the Sun can't reach us by conduction or convection. Only radiation can travel through empty space.

Some of the energy travels as light rays that we can see. Some of the energy travels as infra-red rays that we can feel.

- 3 Energy can't be conducted or convected from the Sun to Earth. Explain why not.
- 4 Write down another name for empty space.

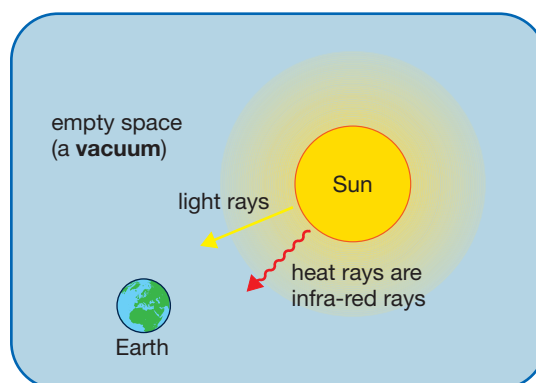

How can you capture the energy in infra-red rays?

Dark, matt (dull) surfaces are good absorbers of infra-red rays. This means that they soak up infra-red radiation very well.

Light, shiny surfaces do not absorb infra-red rays very much. They are good at **reflecting** the rays away from themselves.

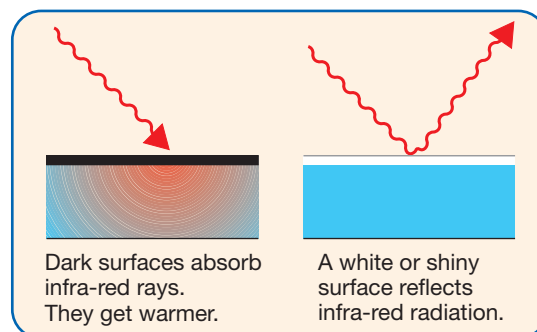

- 5 Look at the pictures below.
 Write a sentence to explain each one.

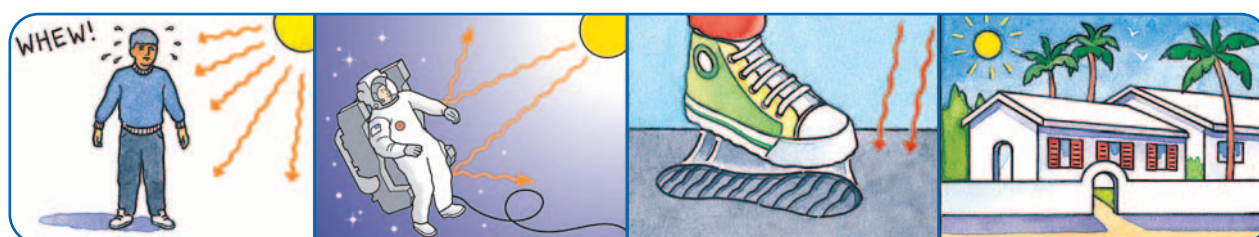

Dark clothes make you feel hot on a sunny day. Astronauts wear shiny suits for space walks. The tar on roads can melt in the summer sun. Houses in hot countries are often white.

What makes a good radiator?

Dark, matt surfaces give out heat very well. We say that they are good emitters of infra-red rays. This means they give out infra-red rays very well.

Light, shiny surfaces don't give out as much radiation as dark surfaces at the same temperature. They are poor emitters of infra-red rays.

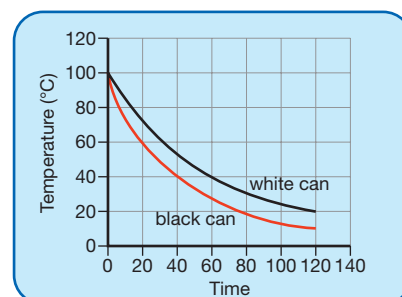
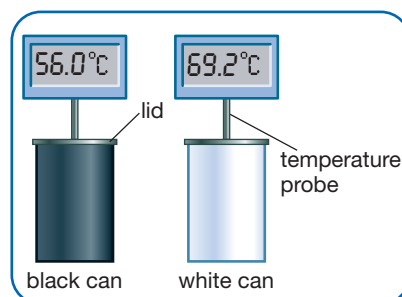

A student uses a temperature probe to record how fast hot water in two metal cans cools. One can is painted black, one white. Otherwise the cans are identical.

- 6 Look at the pictures. Which can cooled faster?
- 7 Explain the difference in the speeds at which the cans cooled.

What you need to remember *Copy and complete using the key words*

Thermal radiation

Infra-red rays can travel through empty _____.

Another name for empty space is a _____.

Heat radiation is also called _____ radiation.

A _____, _____ surface is good at absorbing and emitting infra-red radiation.

A _____, _____ surface is poor at absorbing and emitting infra-red radiation.

Light, shiny surfaces are good at _____ radiation.

The hotter something is, the more _____ energy it radiates.

1 How is heat transferred?

2 Using the Sun's energy

Energy reaches the Earth from the Sun. We can make use of this energy if we trap it or concentrate it.

- 1 Describe two ways of concentrating the energy of sunlight.
- 2 How can we make use of this energy?

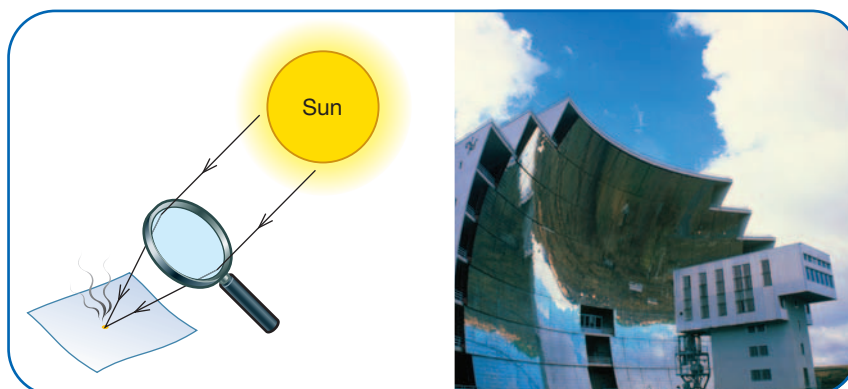

A lens focuses sunlight to a bright spot. The concentrated energy can set fire to paper.

Mirrors on this solar furnace reflect sunlight into a small space. It can produce a temperature of 33 000 °C for scientific experiments.

How can we trap radiation from the Sun?

The diagram shows how a glass window can trap energy from the Sun inside a house.

- 3 Which kind of radiation can pass through glass – high temperature or low temperature?
- 4 Explain how a window traps the Sun's energy in a room.
- 5 Explain how this process can give us lower fuel bills.

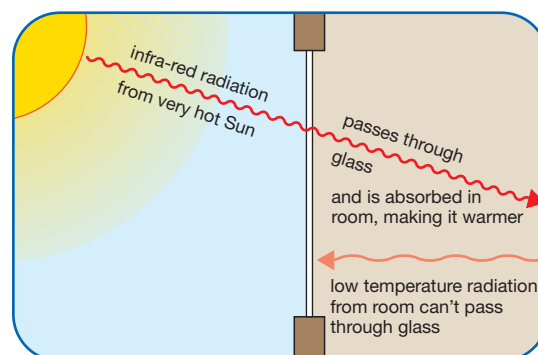

Solar cookers save lives

Refugees in some camps in Africa have no fuel wood. So they've been given solar cookers.

Their water is full of bacteria and must be heated above 65 °C for several minutes to make it safe.

The cooker is made from a curved card sheet. The front surface of the card is painted silver or coated with metal foil. The card concentrates sunlight on a cooking pot at its centre. The pot is made from metal. Its outside surface is blackened.

- 6 Why is the concentrator painted silver or coated with shiny metal foil?
- 7 Why should the cooking pot be black, not white?
- 8 Would this be a good cooker in the UK? Give a reason for your answer.
- 9 What is the advantage of using a metal cooking pot rather than a clay one?

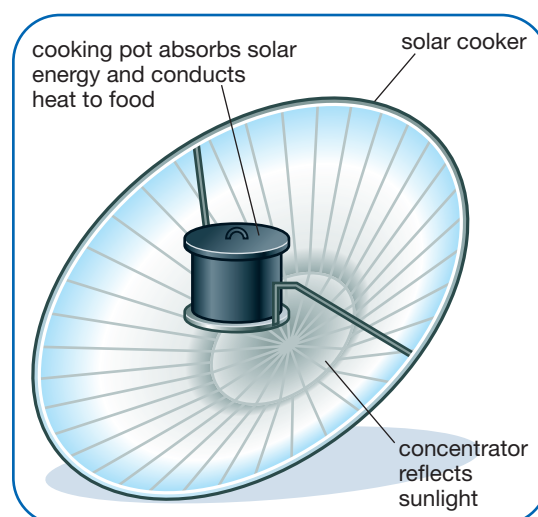

REMEMBER

Light, shiny surfaces are good reflectors and poor emitters.
 Dark, matt surfaces are good absorbers and good emitters.

How does a solar panel work?

Some houses have solar panels on the roof. These use energy radiated by the Sun to heat water. The diagram shows how solar panels work.

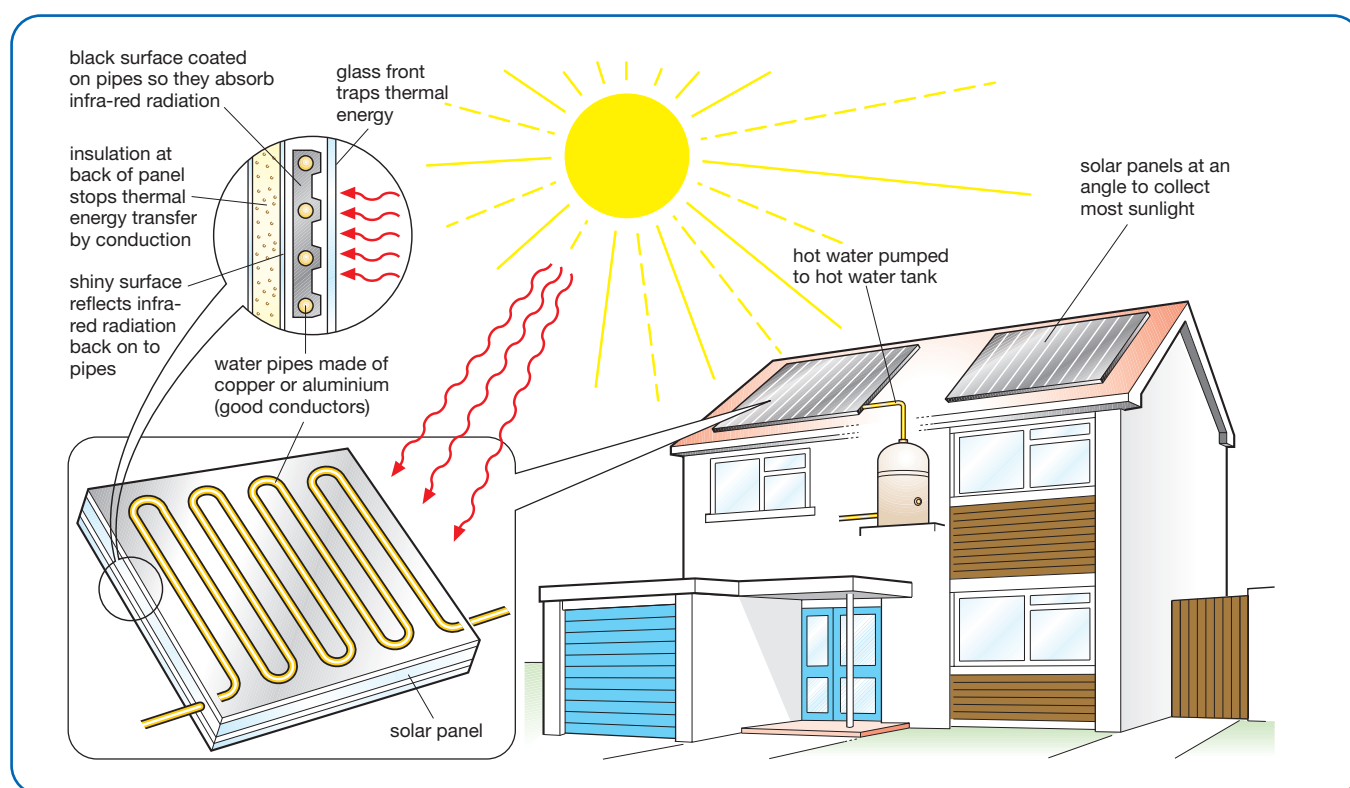

- 10 Look at the diagram. Copy the series of boxes below. Then fill in the missing words.

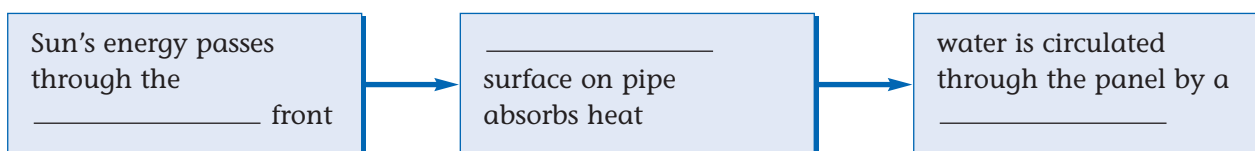

- 11 Why is there a shiny surface behind the water pipes in the solar panel?
- 12 Explain why there is a layer of insulation at the back of the solar panel.

What you need to remember

Using the Sun's energy

There is nothing new for you to remember in this section.

You are using the ideas you have met earlier.

You will sometimes be asked questions like these in tests and examinations.

1 How is heat transferred?

3 Explaining conduction, convection and radiation

Explaining conduction

If you put one end of a metal bar in a flame, heat moves from hot to cold – the far end of the bar soon gets hot too. Heat travels through the metal by **conduction**.

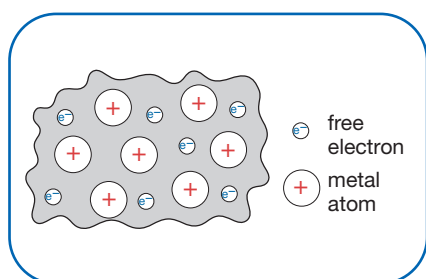

In metals, the electrons that carry electricity can carry heat too. This makes metals good heat conductors.

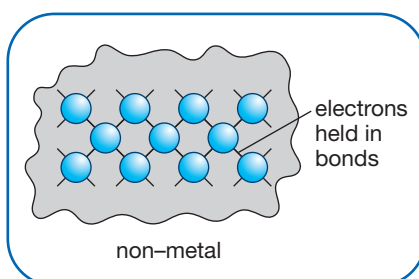

In non-metals such as plastic, wood and oil, all the electrons are held within atoms or molecules. They can't transfer energy, so these substances are poor conductors.

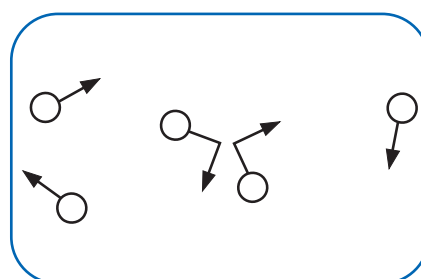

In gases, particles move about and collide with each other. But there are a lot fewer particles in each cm^3 . So gases are poor thermal conductors.

Conduction is the movement of heat from **particle** to particle through a substance. Hot particles move faster than cold particles. They collide with their cooler neighbours and pass on energy.

- 1 How is heat transferred in conduction?
- 2 Why is metal a better conductor than plastic?
- 3 Explain why gases are poor thermal conductors.

Conduction happens in solids, liquids and gases.

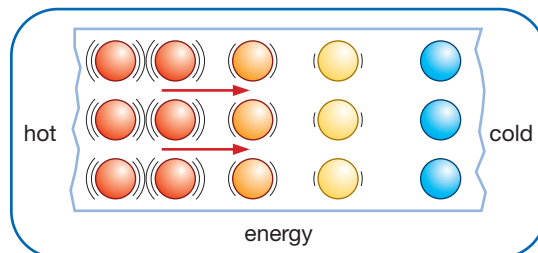

Particles with more energy pass on energy to neighbouring particles by colliding with them.

Explaining convection

Convection happens because **fluids** (liquids and gases) expand when they are warmer. The particles move about faster and take up more space. This means warm fluid is lighter than the same volume of cold fluid. A light fluid floats on top of a heavier one, so hot fluid will float upwards through cold fluid.

- 4 How is heat transferred by convection?
- 5 Why doesn't convection happen in solids?
- 6 Where is the best place to put the heating element in a kettle – at the top or at the bottom? Explain your answer.

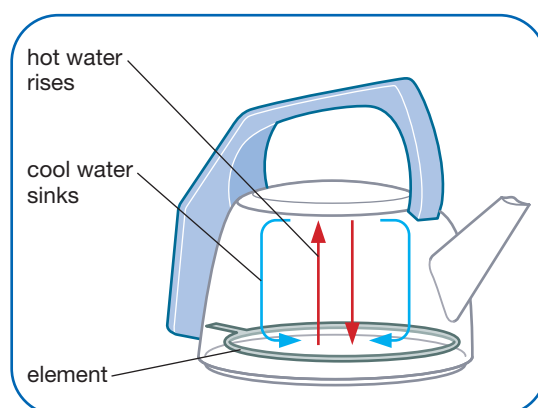

Convection happens in fluids (liquids and gases). Hot water rises and cooler water sinks to take its place. This flow is called a convection current. The convection current carries heat from place to place.



Explaining radiation

Matter is made of particles. Some of the particles have a charge. Heat makes the particles jiggle about. When **charged** particles move like this, they give out electromagnetic **radiation**. The hotter something is, the faster its particles move and the more radiation it emits.

Electromagnetic radiation travels as **waves** through empty space. The radiation from a hot object is absorbed by the charged particles in any object it falls on. In this way, heat is transferred.

- 7 Why is no medium (substance) required for heat transfer by radiation?
- 8 What kind of particles give out and absorb electromagnetic waves?

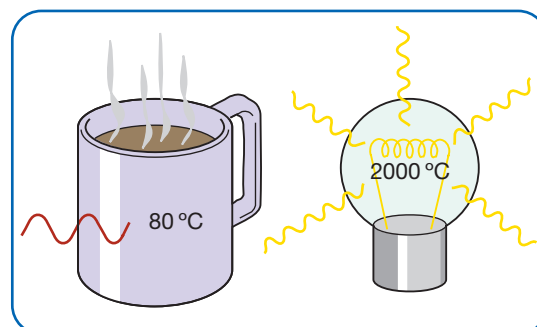

A hot mug emits thermal radiation that you can feel with your skin.

A very hot lamp filament emits light as well as thermal radiation.

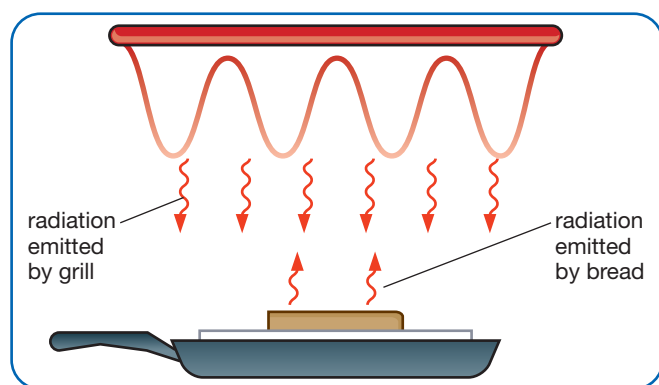

A red-hot grill and a slice of bread both emit and absorb radiation. But the grill emits more radiation than the bread. More heat transfers from the grill to the bread than from the bread to the grill, so the bread heats up.

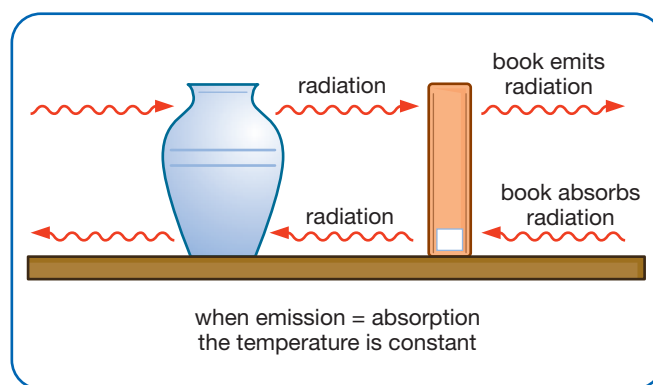

All the objects in this room are at the same temperature. They all emit and absorb infra-red radiation at the same rate. This means there is no overall transfer of energy between them.

- 9 If all the objects in a room are giving out electromagnetic radiation, why do they stay at the same temperature?

What you need to remember *Copy and complete using the key words*

Explaining conduction, convection and radiation

_____ is the transfer of heat from particle to _____ through a material.

_____ is the transfer of heat in _____ by the movement of the particles in a convection current.

_____ is the transfer of heat by electromagnetic _____.

No substance is required between the objects that emit and absorb the radiation.

Radiation is emitted and absorbed by _____ particles.

1 How is heat transferred?

4 What factors affect heat transfer?

Choosing a table mat

A table mat protects a wooden table by reducing conduction from a hot pan to the table surface.

- 1 How do the **dimensions** of the mat affect the rate of heat transfer?
- 2 How does the **material** of the mat affect the rate of heat transfer?

Different materials transfer heat at different rates. We say that a good conductor like copper has a high **conductivity**. An insulator such as cork has a low conductivity.

Material	How many times better the material conducts heat than air
copper	20 000
glass	60
polythene	20
cork	6
air	1

The conductivity of different materials compared with air.

- 3 Which material is the better insulator – cork or polythene?
- 4 Suggest how you could you make a glass table mat as effective as a 3 mm cork table mat.



Why do elephants have big ears?

Elephants' large bodies produce a great deal of waste heat. They must have an effective way of getting rid of this heat.

- 5 Explain how the shape of the elephant's ears helps it get rid of waste heat.
- 6 In what shape container does a hot liquid cool more rapidly?

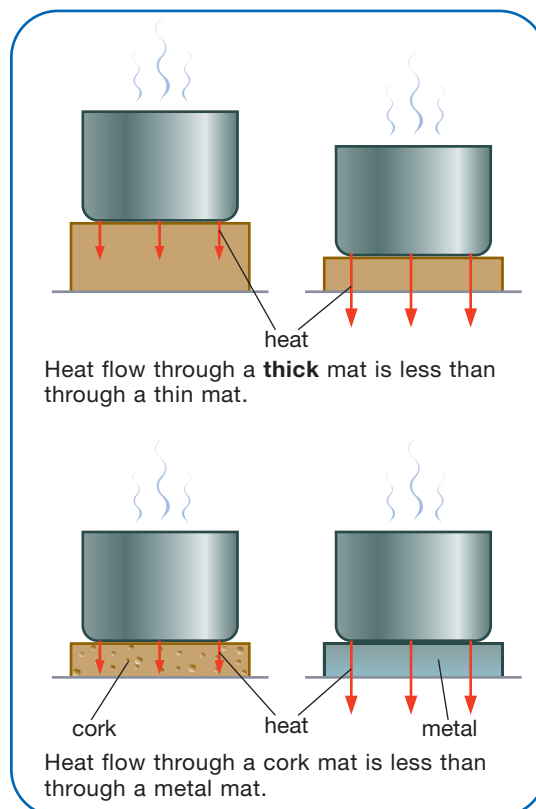

The elephant's ears are well supplied with blood vessels. Their flat shape provides a **large surface area** through which heat can escape.

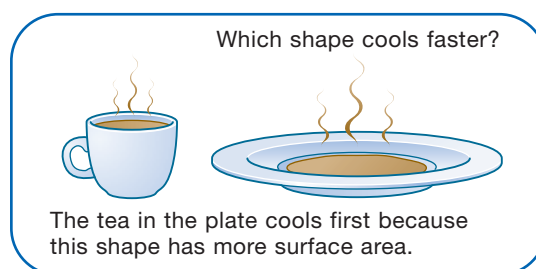

Temperature difference

A hotplate gives out more heat each second when its temperature is high.

Heat transfers from hot to cold at a higher rate if the **temperature difference** is large.

- 7 Why must you increase the power supplied to a hotplate to increase its temperature?
- 8 What are the temperature differences between the room and the insides of the refrigerator and the freezer?
- 9 Explain why a freezer must be better insulated than a refrigerator.

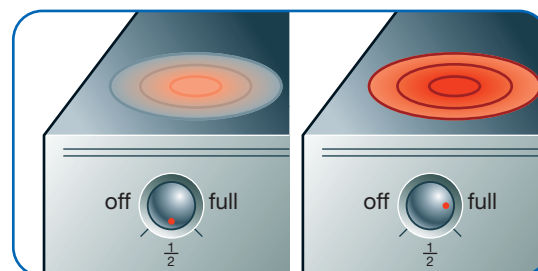

A hotplate on a cooker heats up until the rate it gives out heat exactly balances the electrical power supplied.

When the plate is hotter, it loses heat to the surroundings more rapidly – so more power is needed.

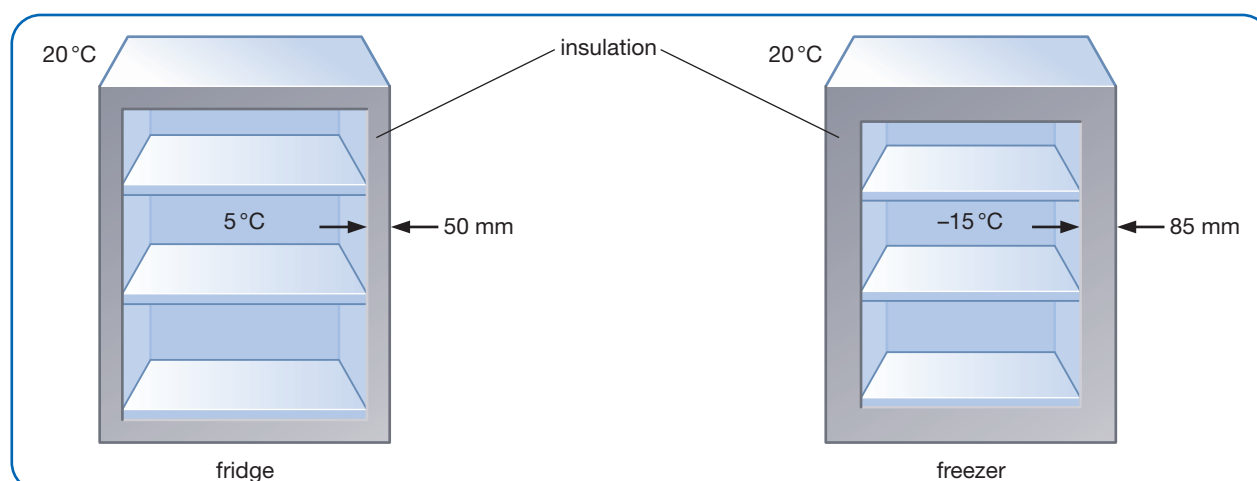

The temperature difference between the inside and the outside is bigger for a freezer than a fridge. The rate of heat flow into the freezer will be bigger. So it will use more power, unless it is provided with better insulation.

What you need to remember *Copy and complete using the key words*

What factors affect heat transfer?

The rate of heat transfer through a material or to and from an object is affected by different factors. These include

- the _____ and shape of an object
- the kind of _____
- the _____ between an object and its surroundings.

A good conductor has a higher _____ than a poor conductor.

A _____ area transfers heat more quickly than a smaller one.

A thin sample transfers heat more quickly than a _____ one.

The higher the temperature difference, the greater the rate of heat transfer.

1 How is heat transferred?

5 Keeping warm outdoors

Choosing a sleeping bag

You need a good sleeping bag and an insulating sleeping mat to keep warm when camping. The bag and the mat reduce heat transfer from your body to the surroundings.

Summer camping

- night-time temperature 10°C
- synthetic fill
- 8 cm 'loft'
- single sleeping mat reduces heat loss to the ground by conduction

Winter camping

- night-time temperature -5°C
- down fill
- 15 cm 'loft'
- hood to prevent heat loss from head
- shiny fabric shell
- double sleeping mat

- 1** Explain why
 - a a down-filled bag is warmer than a similar bag filled with synthetic fibres
 - b 15 cm of insulation is more effective than 8 cm
 - c the inside and outside shells of the winter bag are made from shiny fabric
 - d a double sleeping mat is needed at -5°C.
- 2** Which is the better filling to choose for a sleeping bag in wet conditions? Give a reason for your answer.

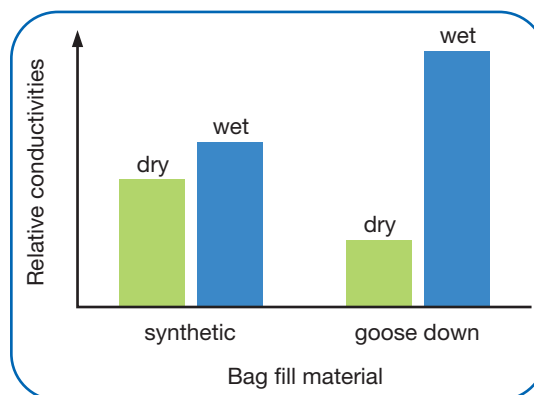

A hot drink

You can keep a drink hot all day in a vacuum flask. Its design prevents heat loss by conduction, convection and radiation.

- 3** Why is the flask made with a vacuum space between the glass walls?
- 4** Why are the inside and outside walls silvered?
- 5** How is heat loss from the liquid surface reduced?
- 6** Explain why heat cannot pass through a vacuum by conduction and convection.

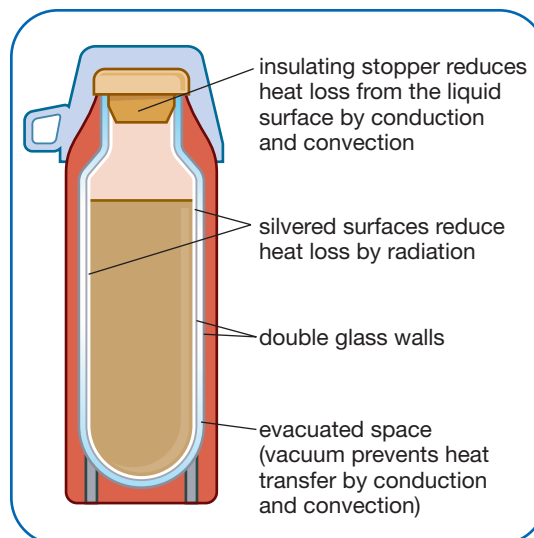

Keeping warm at the end of a race

In a marathon race, runners' bodies produce a lot of heat. They wear light clothes and sweat. This keeps them cool.

When they stop running, the combination of light clothes and wet skin means that they lose heat rapidly. There is a risk of hypothermia (dangerously low body temperature).

To prevent hypothermia, officials wrap the runners in space blankets as they finish.

- 7 Why is the space blanket silvered?
- 8 How does the space blanket reduce heat loss by convection?
- 9 How does it reduce heat loss by conduction?
- 10 Why is a space blanket more effective than a black bin liner?
- 11 Some athletes curl into a ball beneath their space blankets. How does this change their outer surface area? What effect does this have on their rate of heat loss?



When a liquid evaporates, it carries away heat. You can feel the cooling effect when perfume evaporates from your skin. The evaporation of sweat cools the body in the same way.



The silvered inner surface of the blanket reflects radiation back to the runner's body. The silvered outer surface reduces heat loss by radiation. Wrapping the blanket around the body creates a barrier to reduced heat loss by convection. It also traps an insulating layer of air to reduce heat loss by conduction.

What you need to remember

Keeping warm outdoors

There is nothing new for you to remember in this section.

You are using the ideas you met earlier.

You will sometimes be asked questions like these in tests and examinations.

1 How is heat transferred?

6 Reducing heat loss from buildings

We're being robbed of our joules!

All buildings lose heat in various ways.

This costs money and wastes fuel.

- 1 Look at the diagram. Then, copy and complete the table. (A joule (J) is a unit of energy.)

Part of house	Heat lost each second (J)
ceiling	
window glass	
floor	
draughts	
walls	

- 2 Copy and complete the sentences.

Heat moves through walls by _____.

Draughts are caused by _____

_____.

Heat moves up to ceilings by convection and then moves through ceilings by _____.

Heat moves through window glass by _____

_____ and through the floor by

conduction. The biggest loss of heat is through the _____.

_____.

An energy-saving idea

The heat from the back of a radiator is transferred to the wall by radiation. The heat then moves through the wall by conduction. The diagram shows how to reduce this heat loss.

- 3 Copy and complete the sentences.

The shiny surface behind the radiator will _____ the infra-red rays back into the room. Plastic foam in wall cavities prevents heat loss by _____ without increasing heat loss by _____.

The most **effective** method is the one that reduces heat loss by the biggest percentage (%).

- 4 Which method of reducing the heat loss through the wall is the most effective?

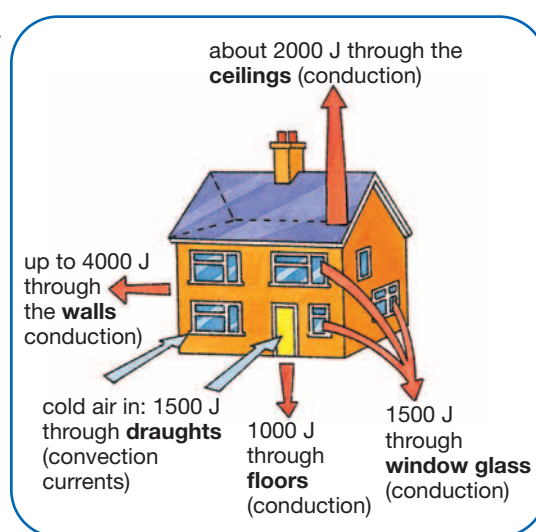

Lots of thermal energy is lost each second from a badly insulated house on a cold day.

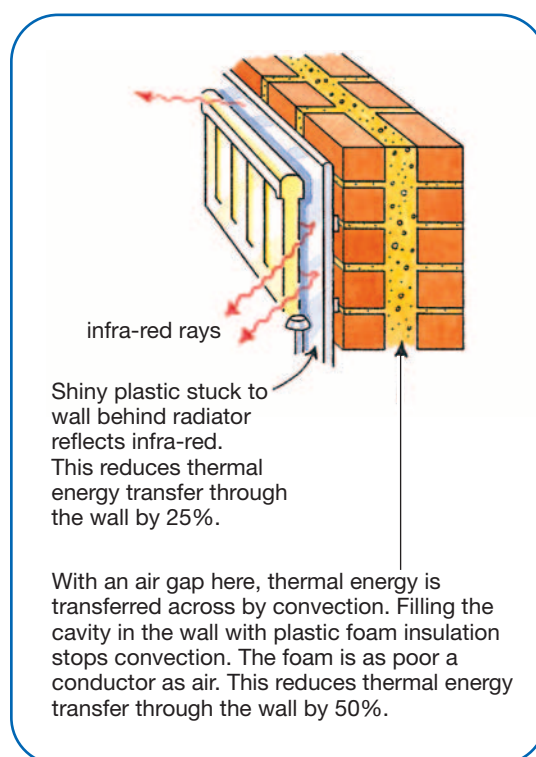

There are several ways to reduce thermal energy loss through a wall.

More ways of reducing energy loss

- 5 Suppose that all the energy-saving ideas on these pages are used in the house shown at the top of page 20.
- Draw a picture of the house and label the heat losses now that it is insulated.
 - What is the total thermal energy loss for the insulated house?
 - How does this compare with the uninsulated house?

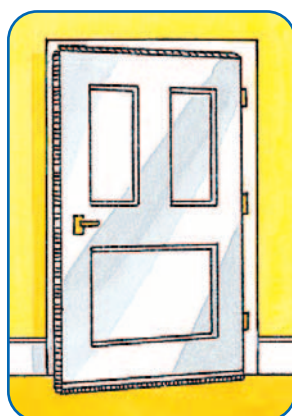

Draught excluders (strips) around doors and windows can save half of the heat lost through draughts.

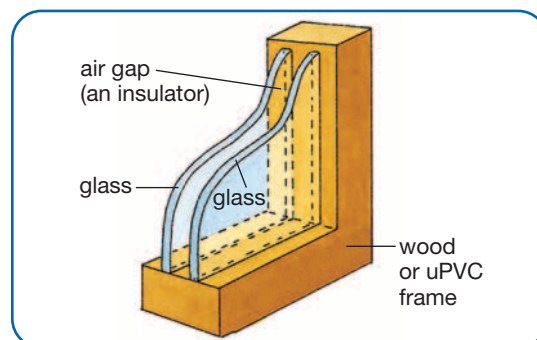

Double glazing can save about half of the thermal energy lost through windows.



Insulating the loft with glass fibre 20 cm thick can save half of the thermal energy lost through the ceiling.

Why do foam and fibres make good insulators?

Air, like all gases, is a very poor **conductor**. But to use it as an insulator, we must stop it moving about.

Look at the diagrams of foam and fibre **insulation**.

- Describe how the air is stopped from moving about in the foam and the fibre insulation.
- Why is it important to stop the air moving about?

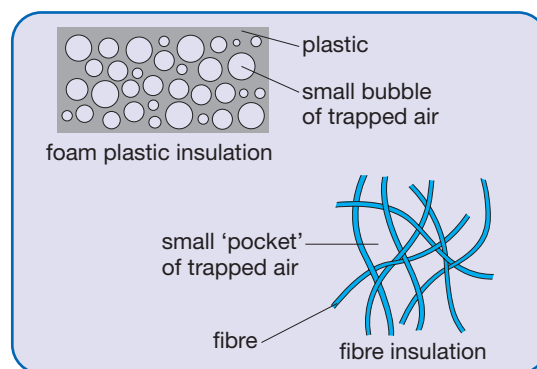

What you need to remember *Copy and complete using the key words*

Reducing heat loss from buildings

Heat can be lost from buildings by conduction through the _____, _____, _____ and _____.

It is also lost by convection because of _____.

You can save heat by _____ the loft, fitting draught excluders, putting in cavity wall insulation and _____.

Some methods reduce the amount of heat loss by a bigger percentage (%) than others. So we say that they are more _____.

Materials that are used for _____ often contain air. This air is trapped so it can't move about. A gas, such as air, is a very poor _____.