



HP 17 Laptop PC
HP 17g Laptop PC
HP 17q Laptop PC

Maintenance and Service Guide

© Copyright 2017, 2108 HP Development Company, L.P.

Bluetooth is a trademark owned by its proprietor and used by HP Inc. under license. Intel, Celeron, and Pentium are trademarks of Intel Corporation in the U.S. and other countries. Windows is either a registered trademark or trademark of Microsoft Corporation in the United States and/or other countries.

In accordance with Microsoft's support policy, HP does not support the Windows 8 or Windows 7 operating system on products configured with Intel and AMD 7th generation and forward processors or provide any Windows 8 or Windows 7 drivers on <http://www.support.hp.com>.

The information contained herein is subject to change without notice. The only warranties for HP products and services are set forth in the express warranty statements accompanying such products and services. Nothing herein should be construed as constituting an additional warranty. HP shall not be liable for technical or editorial errors or omissions contained herein.

Third Edition: April 2018

Second Edition: August 2017

First Edition: April 2017

Document Part Number: 926124-003

Product notice

This guide describes features that are common to most models. Some features may not be available on your computer.

Not all features are available in all editions or versions of Windows. Systems may require upgraded and/or separately purchased hardware, drivers, software or BIOS update to take full advantage of Windows functionality. Windows 10 is automatically updated, which is always enabled. ISP fees may apply and additional requirements may apply over time for updates. Go to <http://www.microsoft.com> for details.

To access the latest user guides or manuals for your product, go to <http://www.hp.com/support>, and select your country. Select **Find your product**, and then follow the on-screen instructions.

Software terms

By installing, copying, downloading, or otherwise using any software product preinstalled on this computer, you agree to be bound by the terms of the HP End User License Agreement (EULA). If you do not accept these license terms, your sole remedy is to return the entire unused product (hardware and software) within 14 days for a full refund subject to the refund policy of your seller.

For any further information or to request a full refund of the price of the computer, please contact your seller.

Safety warning notice

 **WARNING!** To reduce the possibility of heat-related injuries or of overheating the device, do not place the device directly on your lap or obstruct the device air vents. Use the device only on a hard, flat surface. Do not allow another hard surface, such as an adjoining optional printer, or a soft surface, such as pillows or rugs or clothing, to block airflow. Also, do not allow the AC adapter to contact the skin or a soft surface, such as pillows or rugs or clothing, during operation. The device and the AC adapter comply with the user-accessible surface temperature limits defined by the International Standard for Safety of Information Technology Equipment (IEC 60950-1).

Table of contents

1 Product description	1
2 Getting to know your computer	7
Right side	7
Left side	8
Display	9
Keyboard area	10
TouchPad	10
Lights	11
Button	12
Special keys	13
Bottom	14
Labels	15
3 Illustrated parts catalog	17
Computer major components	17
Display assembly subcomponents	22
Miscellaneous parts	24
Mass storage devices	25
4 Removal and replacement procedures preliminary requirements	27
Tools required	27
Service considerations	27
Plastic parts	27
Cables and connectors	27
Drive handling	28
Grounding guidelines	28
Electrostatic discharge damage	28
Packaging and transporting guidelines	29
Workstation guidelines	29
5 Removal and replacement procedures for Customer Self-Repair parts	31
Component replacement procedures	31
Battery	32
Optical drive	34

6 Removal and replacement procedures for Authorized Service Provider parts	37
Component replacement procedures	37
Display subcomponents (bezel, webcam, panel)	37
Bottom cover	41
Hard drive	43
WLAN module	45
RTC battery	47
Memory module	48
Solid-state drive	50
Solid-state drive holder and board	51
Optical drive connector	53
TouchPad click board	54
TouchPad board	55
USB board	56
Speakers	57
Fan	58
Heat sink assembly	59
System board	64
Display assembly	67
Power button board	79
Power connector	80
Top cover/keyboard	81
7 Using Setup Utility (BIOS)	83
Starting Setup Utility (BIOS)	83
Updating Setup Utility (BIOS)	83
Determining the BIOS version	83
Downloading a BIOS update	84
8 Backing up, restoring, and recovering	85
Creating recovery media and backups	85
Creating HP Recovery media (select products only)	85
Using Windows tools	86
Restore and recovery	87
Recovering using HP Recovery Manager	87
What you need to know before you get started	87
Using the HP Recovery partition (select products only)	88
Using HP Recovery media to recover	88
Changing the computer boot order	89
Removing the HP Recovery partition (select products only)	89

9 Using HP PC Hardware Diagnostics (UEFI)	91
Downloading HP PC Hardware Diagnostics (UEFI) to a USB device	92
10 Specifications	93
Computer specifications	93
43.9-cm (17.3-in) display specifications	94
Hard drive specifications	94
M.2 solid-state drive specifications	95
DVD±RW SuperMulti DL Drive specifications	96
11 Power cord set requirements	97
Requirements for all countries	97
Requirements for specific countries and regions	98
12 Recycling	101
Index	103

1 Product description

Category	Description	UMA	Discrete R17M-M1-30 2GB	Discrete R17M-M1-70 2GB	Discrete R17M-M1-70 4GB
Product name	HP 17 Laptop PC	✓	✓	✓	✓
	Model numbers: 17-bs000 – 17-bs099	✓	✓	✓	✓
	HP 17g Laptop PC	✓	✓	✓	✓
	Model numbers: 17-br000 – 17-br099	✓	✓	✓	✓
	HP 17q Laptop PC	✓	✓	✓	✓
	Model numbers: 17-bu000 – 17-bu099	✓	✓	✓	✓
	HP 17 Laptop PC	✓	✓	✓	✓
	Model numbers: 17-bs100 – 17-bs199	✓	✓	✓	✓
	HP 17g Laptop PC			✓	
	Model numbers: 17-br100 – 17-br199			✓	
	HP 17q Laptop PC			✓	
	Model numbers: 17-bu100 – 17-bu199			✓	
	Processors	8th generation Intel® Core™ processors			✓
Intel Core i5-8250U (1.6-GHz, turbo up to 3.4 GHz, 6-MB L3 cache, 2400-MHz, quad, 15W)		✓	✓		✓
7th generation Intel Core processors		✓	✓		✓
Intel Core i7-7500U (2.7-GHz, turbo up to 3.5 GHz, 4-MB L3 cache, 2133-MHz, dual, 15W)		✓	✓		✓
Intel Core i5-7200U (2.5-GHz, turbo up to 3.1 GHz, 3-MB L3 cache, 2133-MHz, dual, 15W)		✓	✓	✓	
Intel Core i3-7100U (2.4-GHz, 3-MB L3 cache, 2133-MHz, dual, 15W)		✓			
Intel Core i3-6006U (2.0-GHz, 3-MB L3 cache, 2133-MHz, dual, 15W)		✓	✓		
Intel Pentium® and Celeron® processors		✓	✓		
Intel Pentium N4200 (1.1-GHz, turbo up to 2.5 GHz, 2-MB L3 cache, 1866-MHz, quad, 6W)		✓	✓		
Intel Pentium N3710 (1.6-GHz, turbo up to 2.56 GHz, 2-MB L3 cache, 1600-MHz, quad, 6W)		✓	✓		
Intel Celeron N3350 (1.1-GHz, turbo up to 2.4 GHz, 2-MB L3 cache, 1866-MHz, quad, 6W)		✓			
Intel Celeron N3060 (1.6-GHz, turbo up to 2.48 GHz, 2-MB L3 cache, 1600-MHz, quad, 6W)		✓			

Category	Description	UMA	Discrete R17M-M1-30 2GB	Discrete R17M-M1-70 2GB	Discrete R17M-M1-70 4GB	
Graphics	Internal graphics			√		
	Intel UHD Graphics 620			√		
	Intel HD Graphics 620	√	√	√	√	
	Intel HD Graphics 520	√	√			
	Intel HD Graphics 505	√	√			
	Intel HD Graphics 405	√	√			
	Intel HD Graphics 500	√				
	Intel HD Graphics 400	√				
	Switchable discrete graphics				√	√
	AMD Radeon™ M530 R17M-M1-70 with 4096 MB or 2048 GB of dedicated video memory				√	√
	AMD Radeon M520 R17M-M1-30 with 2048 MB of dedicated video memory			√		
	Support HD Decode, DX12, and HDMI	√	√	√	√	√
	Support Optimus	√	√	√	√	√
	Panel	16:9 Ultra Wide Aspect Ratio, 43.9-cm (17.3-in), WLED, flat-flat (4.0 mm), eDP	√	√	√	√
HD+, SVA, BrightView, (1600×900); typical brightness: 220 nits (non-touch panel)		√	√	√	√	
HD+, SVA, antiglare (1600×900), typical brightness: 220 nits (non-touch panel)		√	√	√	√	
HD+, UWVA, BrightView, (1920×1080); typical brightness: 220 nits (touch panel)		√	√	√	√	
FHD, UWVA, antiglare (1920×1080), typical brightness: 300 nits (non-touch panel)		√	√	√	√	
Memory	One SODIMM slot - non-customer accessible / non-upgradeable	√	√			
	DDR3L-1600-MHz single channel support	√	√			
	Two SODIMM slots - non-customer accessible / non-upgradeable	√	√	√	√	
	DDR4-2400-MHz dual channel support				√	
	DDR4-2133-MHz dual channel support	√	√	√	√	
	DDR3L-1600-MHz dual channel support	√	√			
	Supports up to 16 GB of system RAM in the following configurations:	√	√	√	√	
	• 16384-MB total system memory (8192×2)	√	√	√	√	
	• 12288-MB total system memory (8192×1) + (4096×1)	√	√	√	√	

Category	Description	UMA	Discrete R17M-M1-30 2GB	Discrete R17M-M1-70 2GB	Discrete R17M-M1-70 4GB
	<ul style="list-style-type: none"> 8192-MB total system memory (8192×1) or (4096×2) 	√	√	√	√
	<ul style="list-style-type: none"> 6144-MB total system memory (4096×1) + (2048×1) 	√	√	√	√
	<ul style="list-style-type: none"> 4096-MB total system memory (4096×1) 	√	√	√	√
Hard drives	Supports 6.35-cm (2.5-in) SATA hard drives in 9.5 mm (.37 in) and 7.2 mm (.28 in) thicknesses	√	√	√	√
	7.2mm/9.5 mm share the same bracket	√	√	√	√
	Single HDD configurations:	√	√	√	√
	2-TB, 5400-rpm, 7.2 mm/9.5 mm	√	√	√	√
	1-TB, 5400-rpm, 7.2 mm/9.5 mm	√	√	√	√
	500-GB, 5400-rpm, 7.2 mm	√	√	√	√
	M.2 SATA-3 solid-state drive:	√	√	√	√
	256-GB	√	√	√	√
	128-GB	√	√	√	√
	M.2 SATA configurations (TLC):	√	√	√	√
	512-GB	√	√	√	√
	256-GB	√	√	√	√
	128-GB	√	√	√	√
	Hard drive + solid-state drive configurations:	√	√	√	√
	1-TB, 5400-rpm, 9.5-mm hard drive + 128-GB M.2 SATA-3 solid-state drive	√	√	√	√
Fixed optical drive	Fixed, serial SATA, 9.0-mm tray load	√	√	√	√
	DVD+/-RW Double-Layer SuperMulti writer	√	√	√	√
	Supports zero power optical drive	√	√	√	√
	Supports M-disc	√	√	√	√
Camera and microphone	HP TrueVision HD	√	√	√	√
	HD camera (fixed, no tilt with activity LED, USB 2.0, BSI sensor, f2.0, 720p by 30 frames per second)	√	√	√	√
	Single digital microphone	√	√	√	√
	HP Camera:	√	√	√	√
	VGA camera, indicator LED, USB 2.0, f2.4, 480p by 30 frames per second	√	√	√	√
	Single digital microphone	√	√	√	√
Audio	HP Audio Control	√	√	√	√
	Dual speakers	√	√	√	√





Category	Description	UMA	Discrete R17M-M1-30 2GB	Discrete R17M-M1-70 2GB	Discrete R17M-M1-70 4GB
Ethernet	Integrated 10/100/1000 network interface card (NIC)	✓	✓	✓	✓
Wireless networking	Integrated wireless with single antenna (M.2/PCIe):	✓	✓	✓	✓
	Compatible with Miracast-certified devices	✓	✓	✓	✓
	Support for the following WLAN formats:	✓	✓	✓	✓
	<ul style="list-style-type: none"> Realtek RTL 8188EE 802.11 bgn 1x1 WiFi Adapter 	✓	✓	✓	✓
	<ul style="list-style-type: none"> Realtek RTL8723DE 802.11 bgn 1x1 WiFi + BT 4.2 Combo Adapter 	✓	✓	✓	✓
	<ul style="list-style-type: none"> Realtek RTL8723BE-VB 802.11bgn 1x1 Wi-Fi + BT4.0 Combo Adapter 	✓	✓	✓	✓
	Integrated wireless with dual antennas (M.2/PCIe):	✓	✓	✓	✓
	Compatible with Miracast-certified devices	✓	✓	✓	✓
	Support for the following WLAN formats:	✓	✓	✓	✓
	<ul style="list-style-type: none"> Intel Dual Band Wireless-AC 3168 802.11 ac 1x1 WiFi + BT 4.2 Combo (non-vPro) Intel Dual Band Wireless-AC 7265 802.11AC 2x2 WiFi + BT 4.2 Combo Adapter (non-vPro) 	✓	✓	✓	✓
External media card	HP Multi-Format Digital Media Card Reader	✓	✓	✓	✓
	Support SD/SDHC/SDXC	✓	✓	✓	✓
	Push-pull insertion/removal	✓	✓	✓	✓
Internal Card	One M.2 slot for WLAN	✓	✓	✓	✓
Ports	HDMI version 1.4 supporting 1920 × 1080 @ 60Hz	✓	✓	✓	✓
	RJ-45 (Ethernet, includes link and activity lights)	✓	✓	✓	✓
	USB 3.0 (2)	✓	✓	✓	✓
	USB 2.0 (1)	✓	✓	✓	✓
	AC Smart Pin adapter plug	✓	✓	✓	✓
	Combo audio jack (headphone/microphone)	✓	✓	✓	✓
Keyboard/ pointing devices	Keyboard (includes numeric keypad)	✓	✓	✓	✓
	Full size textured island-style keyboard	✓	✓	✓	✓
	Full size backlit coat UV paint island-style keyboard	✓	✓	✓	✓
	TouchPad	✓	✓	✓	✓
	Image sensor	✓	✓	✓	✓
	Multitouch gestures enabled	✓	✓	✓	✓
	Taps enabled by default	✓	✓	✓	✓
	Support Modern Trackpad Gestures	✓	✓	✓	✓

Category	Description	UMA	Discrete R17M-M1-30 2GB	Discrete R17M-M1-70 2GB	Discrete R17M-M1-70 4GB
Power requirements	Battery (cylindrical)	√	√	√	√
	4-cell, 41-Whr, li-ion battery	√	√	√	√
	3-cell, 31-Whr, li-ion battery	√			
	AC adapters:	√			
	45 W	√			
	65 W		√	√	√
	65 W EM	√	√	√	√
	90 W			√	
	1 meter power cord (C5)	√	√	√	√
Security	TPM 2.0	√	√	√	√
	Kensington Security Lock	√	√	√	√
Operating system	Preinstalled	√	√	√	√
	Windows 10	√	√	√	√
	For Developed Market (ML):	√	√	√	√
	Windows 10 Home ML	√	√	√	√
	Windows 10 Home Plus ML	√	√	√	√
	For Emerging Market (EM/SL):	√	√	√	√
	Windows 10 Home EM/SL	√	√	√	√
	Windows 10 Home Plus EM/SL	√	√	√	√
	Windows 10 Home Value NB EM/SL	√	√	√	√
	Windows 10 Home Value NB Select Geo EM/SL	√	√	√	√
	For China Market:	√	√	√	√
	CPPP Windows 10 Home High End China Language Edition	√	√	√	√
	CPPP Windows 10 Home China Language Edition	√	√	√	√
	For APJ SEAP Market (EM/SL):	√	√	√	√
	SEAP Windows 10 Home EM/SL	√	√	√	√
	SEAP Windows 10 Home Plus	√	√	√	√
	SEAP Windows 10 Home Value Notebook	√	√	√	√
FreeDOS 2.0	√	√	√	√	
Serviceability	End-user replaceable parts:	√	√	√	√
	AC adapter	√	√	√	√
	Battery	√	√	√	√
	Optical drive	√	√	√	√

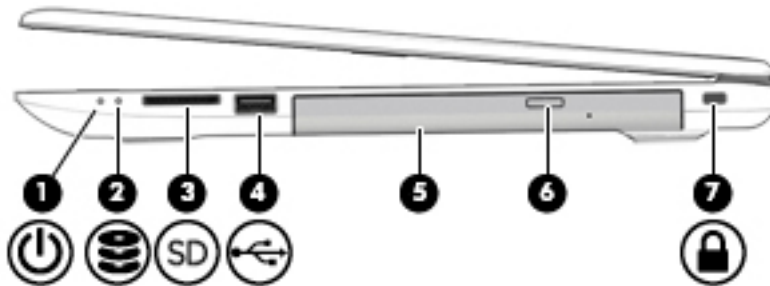
2 Getting to know your computer





Right side

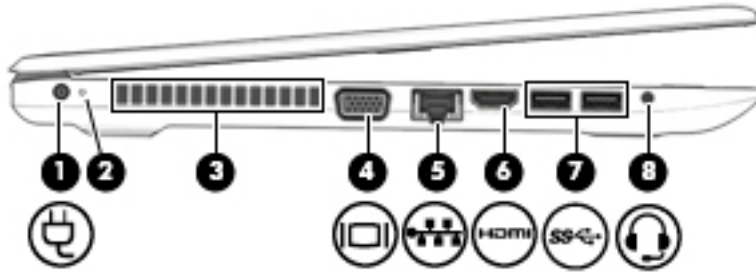

Component	Description
(1)  Power light	<ul style="list-style-type: none">On: The computer is on.Blinking: The computer is in the Sleep state, a power-saving state. The computer shuts off power to the display and other unneeded components.Off: The computer is off or in Hibernation. Hibernation is a power-saving state that uses the least amount of power.
(2)  Drive light	<ul style="list-style-type: none">Blinking white: The hard drive is being accessed.
(3)  SD	<p>Reads optional memory cards that enable you to store, manage, share, or access information.</p> <p>To insert a card:</p> <ol style="list-style-type: none">Hold the card label-side up, with connectors facing the computer.Insert the card into the memory card reader, and then press in on the card until it is firmly seated. <p>To remove a card:</p> <ul style="list-style-type: none">▲ Press in on the card, and then remove it from the memory card reader.
(4)  USB 2.0 port	Connects a USB device, such as a cell phone, camera, activity tracker, or smartwatch, and provides data transfer.
(5) Optical drive	Depending on your computer model, reads an optical disc or reads and writes to an optical disc.
(6) Optical drive eject button	Releases the optical drive disc tray.
(7)  Security cable slot	Attaches an optional security cable to the computer. NOTE: The security cable is designed to act as a deterrent, but it may not prevent the computer from being mishandled or stolen.

Left side



Component	Description
(1) Power connector	Connects an AC adapter.
(2) AC adapter and battery light	<ul style="list-style-type: none"> White: The AC adapter is connected and the battery is fully charged. Blinking white: The AC adapter is disconnected and the battery has reached a low battery level. Amber: The AC adapter is connected and the battery is charging. Off: The battery is not charging.
(3) Vent	Enables airflow to cool internal components. <p>NOTE: The computer fan starts up automatically to cool internal components and prevent overheating. It is normal for the internal fan to cycle on and off during routine operation.</p>
(4)  RJ-45 (network) jack/status lights	Connects a network cable. <ul style="list-style-type: none"> White: The network is connected. Amber: Activity is occurring on the network.
(5)  HDMI port	Connects an optional video or audio device, such as a high-definition television, any compatible digital or audio component, or a high-speed High-Definition Multimedia Interface (HDMI) device.
(6)  USB 3.x SuperSpeed ports (2)	Connect a USB device, such as a cell phone, camera, activity tracker, or smartwatch, and provide high-speed data transfer.
(7)  Audio-out (headphone)/Audio-in (microphone) combo jack	Connects optional powered stereo speakers, headphones, earbuds, a headset, or a television audio cable. Also connects an optional headset microphone. This jack does not support optional standalone microphones. <p>WARNING! To reduce the risk of personal injury, adjust the volume before putting on headphones, earbuds, or a headset. For additional safety information, refer to the <i>Regulatory, Safety, and Environmental Notices</i>.</p> To access this guide: <ul style="list-style-type: none"> ▲ Select the Start button, select HP Help and Support, and then select HP Documentation. <p>NOTE: When a device is connected to the jack, the computer speakers are disabled.</p>

Display

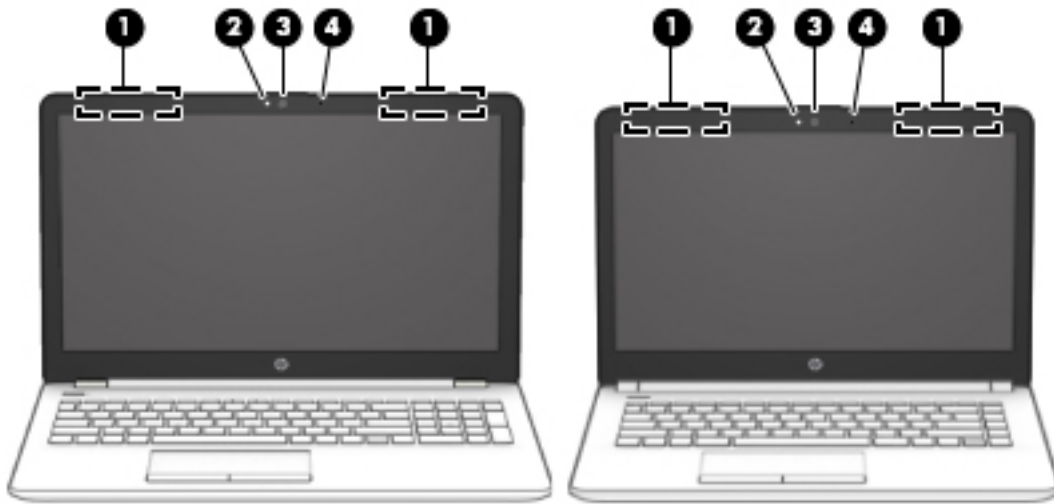

Component	Description
(1) Camera light	On: The camera is in use.
(2) Camera	Allows you to video chat, record video, and record still images.
(3) Internal microphone	Records sound.
(4) WLAN antennas*	Send and receive wireless signals to communicate with wireless local area networks (WLANs).

*The antennas are not visible from the outside of the computer, and antenna location varies. For optimal transmission, keep the areas immediately around the antennas free from obstructions.

For wireless regulatory notices, see the section of the *Regulatory, Safety, and Environmental Notices* that applies to your country or region.

To access this guide:

- ▲ Select the **Start** button, select **HP Help and Support**, and then select **HP Documentation**.

Keyboard area

TouchPad

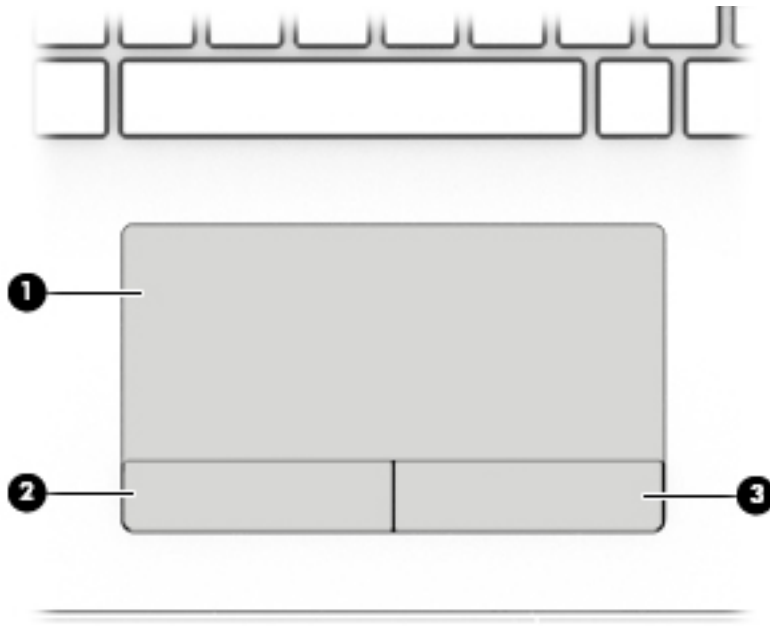

Component		Description
(1)	TouchPad zone	Reads your finger gestures to move the pointer or activate items on the screen.
(2)	Left TouchPad button	Functions like the left button on an external mouse.
(3)	Right TouchPad button	Functions like the right button on an external mouse.

Lights

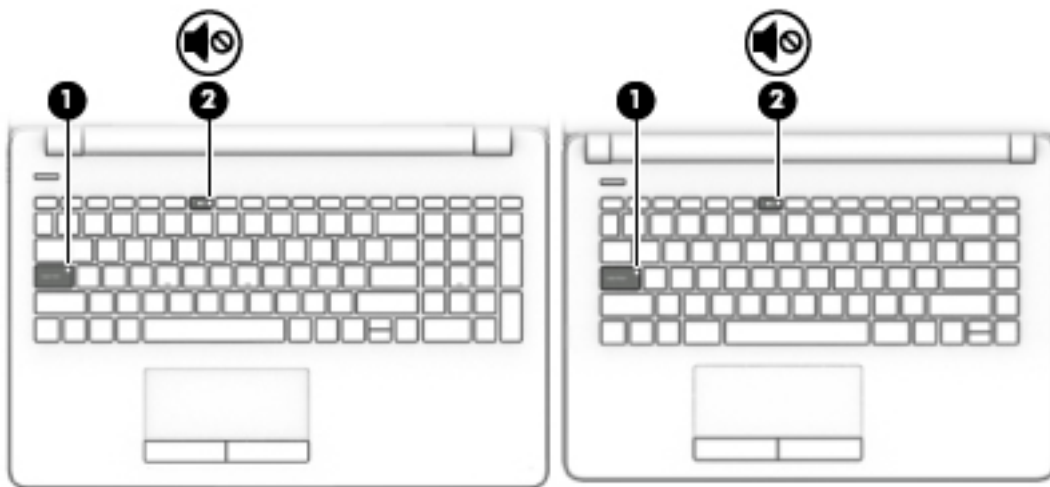

Component	Description
(1) Caps lock light	On: Caps lock is on, which switches the key input to all capital letters.
(2)  Mute light	<ul style="list-style-type: none">• On: Computer sound is off.• Off: Computer sound is on.

Button

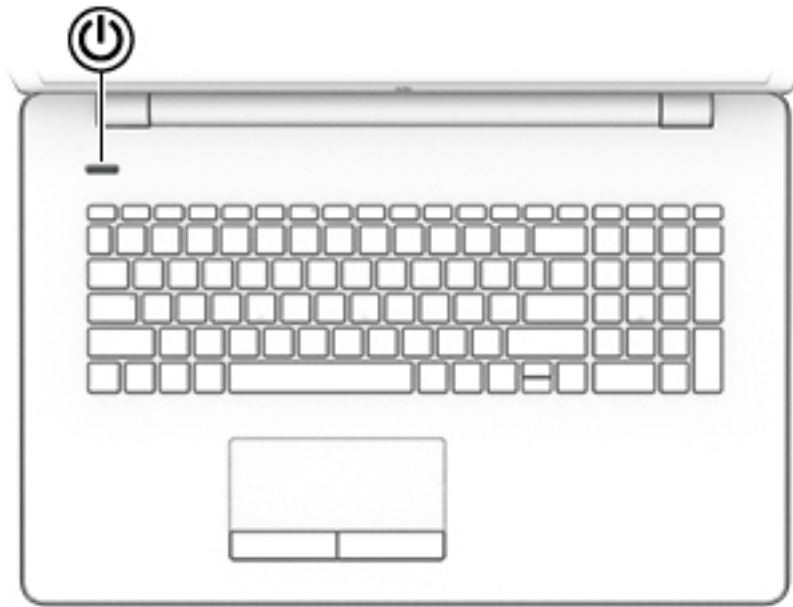

Component	Description
 Power button	<ul style="list-style-type: none">• When the computer is off, press the button to turn on the computer.• When the computer is on, press the button briefly to initiate Sleep.• When the computer is in the Sleep state, press the button briefly to exit Sleep.• When the computer is in Hibernation, press the button briefly to exit Hibernation. <p>CAUTION: Pressing and holding down the power button results in the loss of unsaved information.</p> <p>If the computer has stopped responding and shutdown procedures are ineffective, press and hold the power button down for at least 5 seconds to turn off the computer.</p> <p>To learn more about your power settings, see your power options.</p> <ul style="list-style-type: none">▲ Right-click the Start button, and then select Power Options.

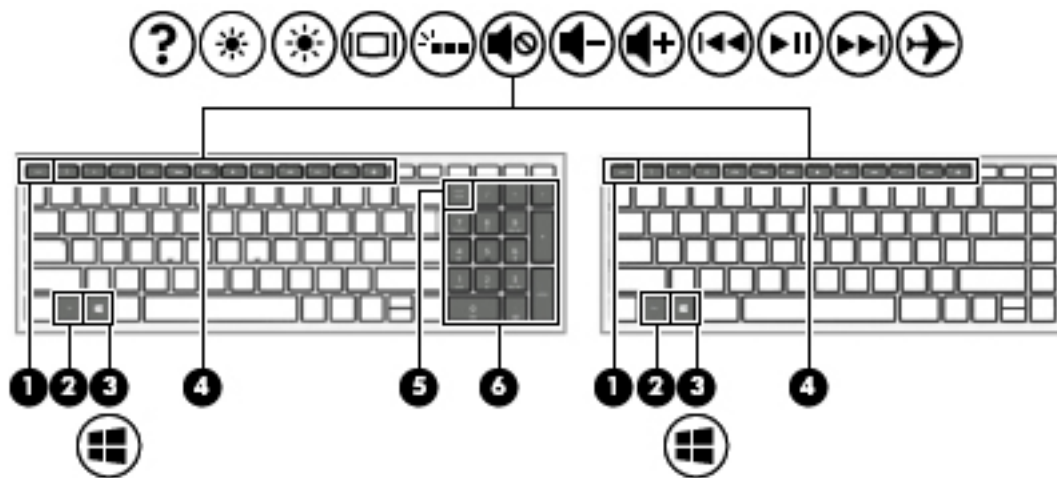

Special keys

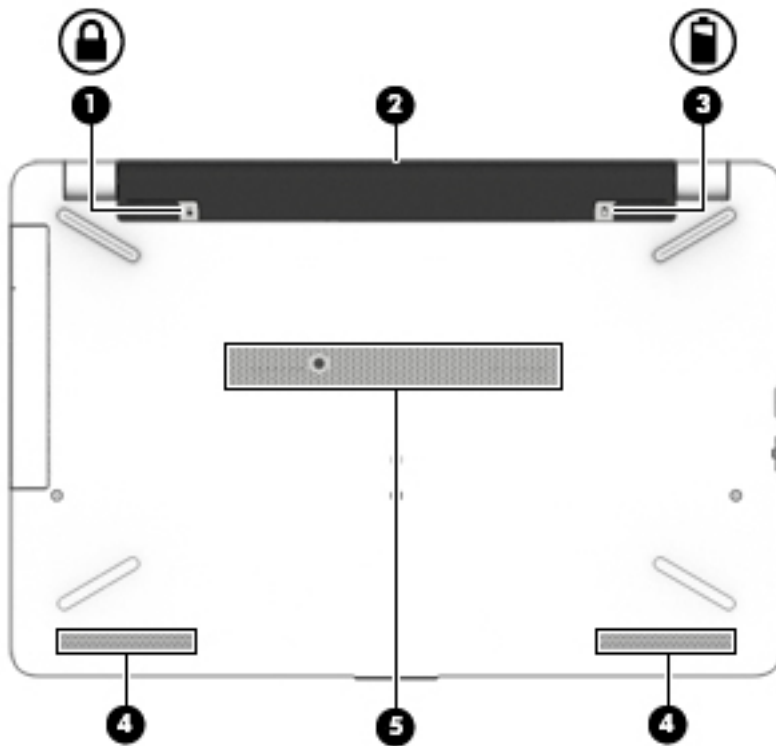

Component	Description
(1) <code>esc</code> key	Displays system information when pressed in combination with the <code>fn</code> key.
(2) <code>fn</code> key	Executes specific functions when pressed in combination with another key.
(3)  Windows key	Opens the Start menu. NOTE: Pressing the Windows key again will close the Start menu.
(4) Action keys	Execute frequently used system functions. NOTE: On select products, the <code>f5</code> action key turns the keyboard backlight feature off or on.
(5) <code>num lock</code> key	Alternates between the navigational and numeric functions on the integrated numeric keypad.
(6) Integrated numeric keypad	A separate keypad to the right of the alphabet keyboard. When <code>num lock</code> is pressed, the keypad can be used like an external numeric keypad. NOTE: If the keypad function is active when the computer is turned off, that function is reinstated when the computer is turned back on.

Bottom



Component		Description
(1)		Speakers Produce sound.
(2)		Battery lock Locks the battery in the battery bay.
(3)		Battery bay Holds the battery.
(4)		Battery release latch Releases the battery.

Labels

The labels affixed to the computer provide information you may need when you troubleshoot system problems or travel internationally with the computer.

IMPORTANT: Check the following locations for the labels described in this section: the bottom of the computer, inside the battery bay, under the service door, or on the back of the display.

- Service label—Provides important information to identify your computer. When contacting support, you will probably be asked for the serial number, and possibly for the product number or the model number. Locate these numbers before you contact support.

Your service label will resemble one of the examples shown below. Refer to the illustration that most closely matches the service label on your computer.

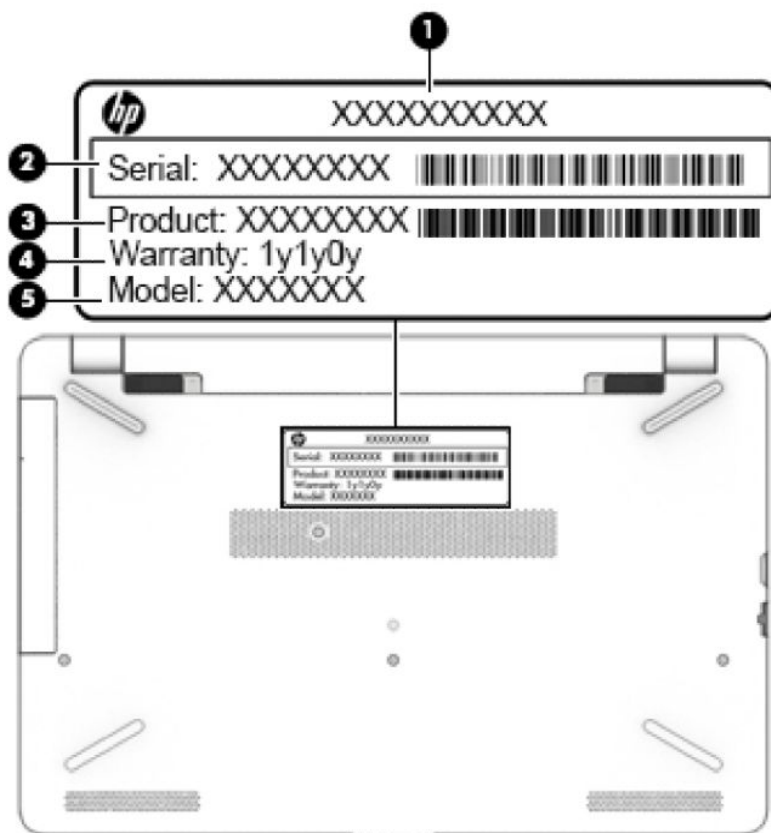

Component

- (1) HP product name
 - (2) Model name
 - (3) Product number
-

Component

(4) Serial number

(5) Warranty period

- Regulatory label(s)—Provide(s) regulatory information about the computer.
- Wireless certification label(s)—Provide(s) information about optional wireless devices and the approval markings for the countries or regions in which the devices have been approved for use.

3 Illustrated parts catalog

Computer major components

 **NOTE:** HP continually improves and changes product parts. For complete and current information on supported parts for your computer, go to <http://partsurfer.hp.com>, select your country or region, and then follow the on-screen instructions.

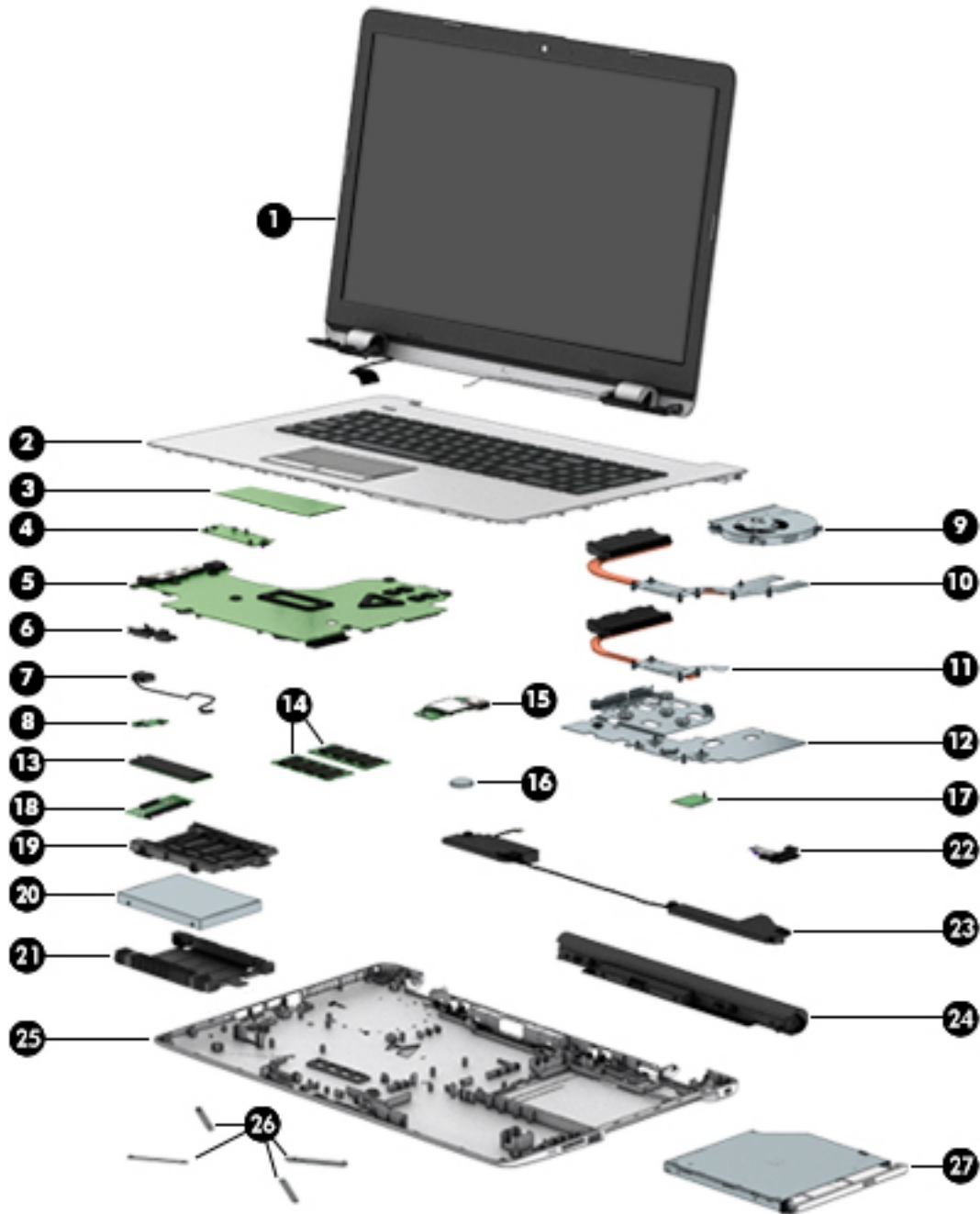

Item	Component	Spare part number
(1)	<p>Display assembly [43.9-cm 17.3-in]</p> <p>NOTE: Displays are only spared at the subcomponent level. For display assembly spare part information, see Display assembly subcomponents on page 22.</p>	
(2)	<p>Top cover/keyboard (includes TouchPad mylar; does not include TouchPad board or TouchPad click board)</p> <p>NOTE: For a detailed list of keyboard country codes, see Top cover/keyboard on page 81.</p>	
	Black	926559-xx1
	Ash silver; not backlit	926560-xx1
	Ash silver; backlit	926562-xx1
	NOTE: Only available in -001 (United States) and -DB1 (French Canada)	
	Snow white	926561-xx1
	Top cover/keyboard - champagne rose, not backlit	934116-001
	Only available in -001 (United States)	
	Top cover/keyboard - champagne rose, backlit	934117-001
	Only available in -001 (United States)	
	Top cover/keyboard - rose gold, not backlit	934118-001
	Only available in -001 (United States)	
	Top cover/keyboard - rose gold, backlit	934119-001
	Only available in -001 (United States)	
	Top cover/keyboard - silk gold, not backlit	L00663-001
	Only available in -001 (United States)	
	Top cover/keyboard - silk gold, backlit	L00664-001
	Only available in -001 (United States)	
(3)	<p>TouchPad board</p> <p>NOTE: The TouchPad board cable is available using spare part number 926518-001. This cable connects from the TouchPad board to the TouchPad click board.</p>	926531-001
(4)	<p>TouchPad click board</p> <p>NOTE: The TouchPad click board cable is available using spare part number 928882-001. This cable connects from the TouchPad click board to the system board.</p>	926530-001
(5)	<p>System board (includes replacement thermal materials)</p> <p>All system boards use the following part numbers:</p> <p>xxxxxx-001: Windows 7 or non-Windows operating system</p> <p>xxxxxx-601: Windows 10</p> <p>For use in models with discrete graphics:</p>	
	<ul style="list-style-type: none"> Intel Core i7-7500U processor and 4 GB of dedicated video memory 	925618-xxx
	<ul style="list-style-type: none"> Intel Core i7-7500U processor and 2 GB of dedicated video memory 	925619-xxx

Item	Component	Spare part number
	<ul style="list-style-type: none"> Intel Core i5-8250U processor and 2 GB of dedicated video memory 	939591-xxx
	<ul style="list-style-type: none"> Intel Core i5-7200U processor and 2 GB of dedicated video memory (M1-70) 	925616-xxx
	<ul style="list-style-type: none"> Intel Core i5-7200U processor and 2 GB of dedicated video memory (M1-30) 	925617-xxx
	<ul style="list-style-type: none"> Intel Core i3-6006U processor and 2 GB of dedicated video memory 	925620-xxx
	<ul style="list-style-type: none"> Intel Pentium N3710 processor and 2 GB of dedicated video memory Intel Pentium N4200 processor and 2 GB of dedicated video memory 	939590-xxx
	<ul style="list-style-type: none"> Intel Pentium N3710 processor and 2 GB of dedicated video memory 	925627-xxx
	For use in models with UMA graphics:	
	<ul style="list-style-type: none"> Intel Core i7-7500U processor 	925623-xxx
	<ul style="list-style-type: none"> Intel Core i5-7200U processor 	925624-xxx
	<ul style="list-style-type: none"> Intel Core i3-7100U processor 	925625-xxx
	<ul style="list-style-type: none"> Intel Core i3-6006U processor 	925626-xxx
	<ul style="list-style-type: none"> Intel Pentium N4200 processor 	939588-xxx
	<ul style="list-style-type: none"> Intel Pentium N3710 processor 	925621-xxx
	<ul style="list-style-type: none"> Intel Celeron N3350 processor 	939589-xxx
	<ul style="list-style-type: none"> Intel Celeron N3060 processor 	925622-xxx
(6)	Display cable frame guide	926539-001
(7)	Power connector cable	810326-010
(8)	Power button board	926529-001
	NOTE: The power button board cable is available using spare part number 926517-001.	
(9)	Fan	926724-001
	Heat sink assembly (includes replacement thermal materials):	
(10)	For use in models with Intel Core processors and discrete graphics	926523-001
(10)	For use in models with Intel Pentium or Celeron processors and discrete graphics	926525-001
(11)	For use in models with a fan and with Intel Core processors and UMA graphics	926522-001
(11)	For use in models without a fan and with Intel Pentium N3710 or Intel Celeron N3060 processors and UMA graphics	926524-001
(12)	For use in models without a fan and with Intel Pentium N4200 or Intel Celeron N3350 processors and UMA graphics	936457-001
(13)	Solid-state drive	
	Value SSD:	
	<ul style="list-style-type: none"> 256 GB 	865902-014
	<ul style="list-style-type: none"> 128 GB 	827560-045
	TLC:	
	<ul style="list-style-type: none"> 512 GB 	763008-016

Item	Component	Spare part number
	<ul style="list-style-type: none"> 256 GB 	760615-044
	<ul style="list-style-type: none"> 128 GB 	759848-025
(14)	Memory module (PC3L, 12800, 1600-MHz)	
	PC3L-1600	
	For use in models with Intel Pentium and Celeron processors	
	<ul style="list-style-type: none"> 8-GB 	693374-005
	<ul style="list-style-type: none"> 4 GB 	691740-005
	PC4-2400	
	For use in models with Intel Core processors	
	<ul style="list-style-type: none"> 8-GB 	862398-855
	<ul style="list-style-type: none"> 4 GB 	862397-855
	<ul style="list-style-type: none"> 2 GB 	864271-855
(15)	USB board	926528-001
	NOTE: The USB board cable is available using spare part number 926516-001.	
(16)	RTC battery	926546-001
(17)	WLAN module	
	Intel Dual Band Wireless-AC 7265 802.11 AC 2x2 WiFi + BT 4.2 Combo Adapter (non-vPro)	793840-005
	Realtek RTL8723DE 802.11 bgn 1x1 WiFi + BT 4.2 Combo Adapter	927230-855
	Realtek RTL 8188EE 802.11 bgn 1x1 WiFi Adapter	927235-855
	Intel Dual Band Wireless-AC 3168 802.11 ac 1x1 WiFi + BT 4.2 Combo	863934-855
(18)	Solid-state drive board	856614-001
(19)	Solid-state drive holder	858260-001
(20)	Hard drive (does not include bracket)	
	2-TB, 5400-rpm, 2.5 inch	912487-855
	1-TB, 5400-rpm, 2.5 inch	676423-855
	500-GB, 5400-rpm, 2.5 inch	683839-855
(21)	Hard drive holder	905974-001
(22)	Optical Drive Connector Cable Kit	926521-001
(23)	Speakers (includes left and right speakers and cable)	926558-001
(24)	Battery	
	4-cell, 41-Whr, 2.8-Ah Li-ion	919701-850
	3-cell, 31-Whr, 2.8-Ah Li-ion	919700-850
(25)	Bottom cover	
	Pike silver	926493-001

Item	Component	Spare part number
	Silk gold	926494-001
	Smoke gray	926495-001
	Marine blue	926496-001
	Amethyst purple	926497-001
	Pale mint	926498-001
	Champagne rose	926499-001
	Jet black	926500-001
	Snow white	926501-001
	Empress red	926502-001
	Rose gold	926503-001
(26)	Rubber Kit (includes front and rear feet)	
	Pike silver	926547-001
	Silk gold	926548-001
	Smoke gray	926549-001
	Marine blue	926550-001
	Amethyst purple	926551-001
	Champagne rose	926552-001
	Jet black	926553-001
	Snow white	926554-001
	Empress red	926555-001
	Rose gold	926556-001
	Pale mint	926557-001
(27)	DVD+/-RW Double-Layer SuperMulti Drive	920417-009

Display assembly subcomponents

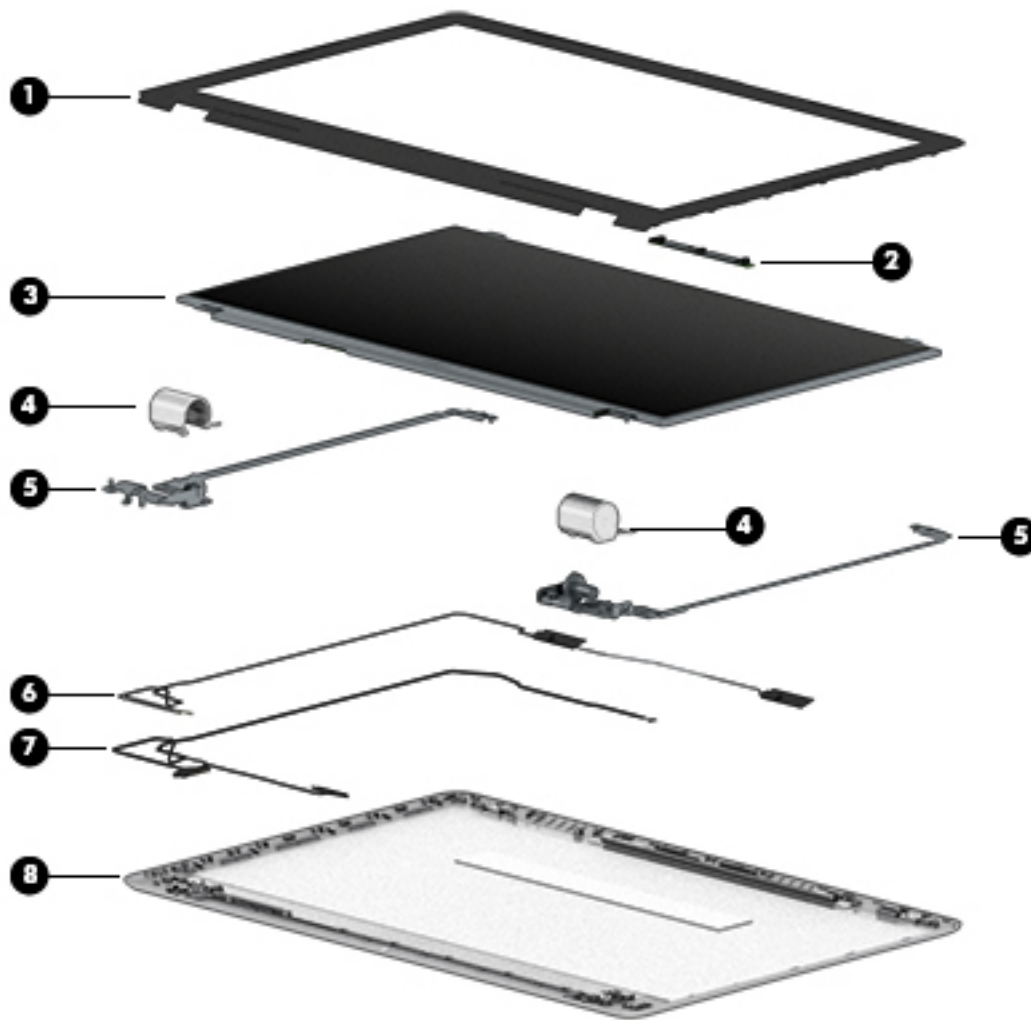

Item	Component	Spare part number
(1)	Display bezel	926504-001
(2)	Webcam/microphone module	
	HD	919471-003
	VGA	919472-003
(3)	Touch control board (includes tape and EMI foil)	926532-001
(4)	Raw display panel (16:9 Ultra Wide Aspect Ratio [43.9-cm 17.3-in])	
	FHD, anti glare, non-touch	798926-011
	HD, Touch On Panel (TOP)	851049-003
	HD+, BrightView, non-touch	851051-005
	HD+, anti glare, non-touch	910136-003
(5)	Hinge covers	

Item	Component	Spare part number
	Left, jet black	926533-001
	Right, jet black	926534-001
	Left, snow white	926535-001
	Right, snow white	926536-001
	Left, pike silver	926537-001
	Right, pike silver	926538-001
	Left, rose gold	926542-001
	Right, rose gold	926543-001
	Left, champagne rose	926544-001
	Right, champagne rose	926545-001
	Left, silk gold	928883-001
	Right, silk gold	928884-001
(6)	Hinges (left and right)	926527-001
(7)	Display cable	
	Touch displays	926520-001
	Non-touch displays	926519-001
(8)	Antennas	
	Dual	926424-001
	Single	926425-001
(9)	Display enclosure	
	For use in non-touch models:	
	• Pike silver	926482-001
	• Silk gold	926483-001
	• Smoke gray	926484-001
	• Marine blue	926485-001
	• Amethyst purple	926486-001
	• Pale mint	926487-001
	• Champagne rose	926488-001
	• Jet black	926489-001
	• Snow white	926490-001
	• Empress red	926491-001
	• Rose gold	926492-001
	• Silk gold	L00661-001
	For use in touch models:	

Item	Component	Spare part number
	• Pike silver	933291-001
	• Silk gold	933292-001
	• Smoke gray	933293-001
	• Marine blue	933294-001
	• Amethyst purple	933295-001
	• Pale mint	933296-001
	• Champagne rose	933297-001
	• Jet black	933298-001
	• Snow white	933299-001
	• Empress red	933300-001
	• Rose gold	933301-001
	• Silk gold	L00662-001

Miscellaneous parts

Component	Spare part number
HP Smart AC adapter	
45-W	741553-850
65-W	710412-001
65-W EM	913691-850
90-W	710413-001
Power cord (3-pin, black, 1.0-m) for use in:	
For use in Australia	920688-011
For use in Denmark	920688-007
For use in Europe	920688-005
For use in India	920688-016
For use in Israel	920688-008
For use in Japan	920688-017
For use in North America	920688-001
For use in the People's Republic of China	920688-014
For use in South Korea	920688-013
For use in Switzerland	920688-009
For use in the United Kingdom	920688-006
Rubber Kit (includes front and rear feet)	

Component	Spare part number
Pike silver	926547-001
Silk gold	926548-001
Smoke gray	926549-001
Marine blue	926550-001
Amethyst purple	926551-001
Champagne rose	926552-001
Jet black	926553-001
Snow white	926554-001
Empress red	926555-001
Rose gold	926556-001
Pale mint	926557-001
Screw Kit	926725-001
HDMI to VGA adapter	701943-001

Mass storage devices

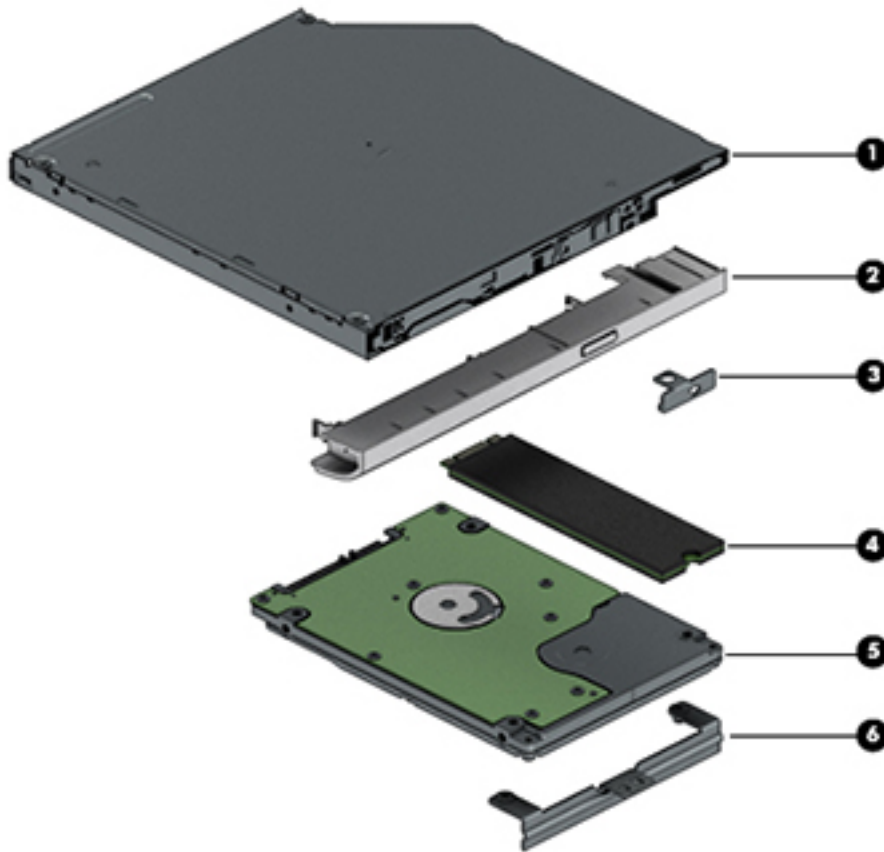

Item	Component	Spare part number
(1)	DVD+/-RW Double-Layer SuperMulti Drive	920417-009
(2)	Optical drive bezel	
	Pike silver	926505-001
	Silk gold	926506-001
	Smoke gray	926507-001
	Marine blue	926508-001
	Amethyst purple	926509-001
	Pale mint	926510-001
	Champagne rose	926511-001
	Jet black	926512-001
	Snow white	926513-001
	Empress red	926514-001
	Rose gold	926515-001
(3)	Optical drive bracket	926526-001
(4)	Hard drive (does not include bracket)	
	2-TB, 5400-rpm, 2.5 inch	912487-855
	1-TB, 5400-rpm, 2.5 inch	676423-855
	500-GB, 5400-rpm, 2.5 inch	683839-855
(5)	Hard drive holder	905974-001
(6)	Solid-state drive holder	858260-001
(7)	Solid-state drive board	856614-001
(8)	Solid-state drive	
	Value SSD:	
	• 256 GB	865902-014
	• 128 GB	827560-045
	TLC:	
	• 512 GB	763008-016
	• 256 GB	760615-044
	• 128 GB	759848-025

4 Removal and replacement procedures preliminary requirements

Tools required

You will need the following tools to complete the removal and replacement procedures:

- Flat-bladed screwdriver
- Magnetic screwdriver
- Phillips P0 and P1 screwdrivers

Service considerations

The following sections include some of the considerations that you must keep in mind during disassembly and assembly procedures.

 **NOTE:** As you remove each subassembly from the computer, place the subassembly (and all accompanying screws) away from the work area to prevent damage.

Plastic parts

 **CAUTION:** Using excessive force during disassembly and reassembly can damage plastic parts. Use care when handling the plastic parts. Apply pressure only at the points designated in the maintenance instructions.

Cables and connectors

 **CAUTION:** When servicing the computer, be sure that cables are placed in their proper locations during the reassembly process. Improper cable placement can damage the computer.

Cables must be handled with extreme care to avoid damage. Apply only the tension required to unseat or seat the cables during removal and insertion. Handle cables by the connector whenever possible. In all cases, avoid bending, twisting, or tearing cables. Be sure that cables are routed in such a way that they cannot be caught or snagged by parts being removed or replaced. Handle flex cables with extreme care; these cables tear easily.

Drive handling

⚠ CAUTION: Drives are fragile components that must be handled with care. To prevent damage to the computer, damage to a drive, or loss of information, observe these precautions:

Before removing or inserting a hard drive, shut down the computer. If you are unsure whether the computer is off or in Hibernation, turn the computer on, and then shut it down through the operating system.

Before handling a drive, be sure that you are discharged of static electricity. While handling a drive, avoid touching the connector.

Before removing a diskette drive or optical drive, be sure that a diskette or disc is not in the drive and be sure that the optical drive tray is closed.

Handle drives on surfaces covered with at least one inch of shock-proof foam.

Avoid dropping drives from any height onto any surface.

After removing a hard drive, an optical drive, or a diskette drive, place it in a static-proof bag.

Avoid exposing an internal hard drive to products that have magnetic fields, such as monitors or speakers.

Avoid exposing a drive to temperature extremes or liquids.

If a drive must be mailed, place the drive in a bubble pack mailer or other suitable form of protective packaging and label the package "FRAGILE."

Grounding guidelines

Electrostatic discharge damage

Electronic components are sensitive to electrostatic discharge (ESD). Circuitry design and structure determine the degree of sensitivity. Networks built into many integrated circuits provide some protection, but in many cases, ESD contains enough power to alter device parameters or melt silicon junctions.

A discharge of static electricity from a finger or other conductor can destroy static-sensitive devices or microcircuitry. Even if the spark is neither felt nor heard, damage may have occurred.

An electronic device exposed to ESD may not be affected at all and can work perfectly throughout a normal cycle. Or the device may function normally for a while, then degrade in the internal layers, reducing its life expectancy.

⚠ CAUTION: To prevent damage to the computer when you are removing or installing internal components, observe these precautions:

Keep components in their electrostatic-safe containers until you are ready to install them.

Before touching an electronic component, discharge static electricity by using the guidelines described in this section.

Avoid touching pins, leads, and circuitry. Handle electronic components as little as possible.

If you remove a component, place it in an electrostatic-safe container.

The following table shows how humidity affects the electrostatic voltage levels generated by different activities.

⚠ CAUTION: A product can be degraded by as little as 700 V.

Typical electrostatic voltage levels			
Event	Relative humidity		
	10%	40%	55%
Walking across carpet	35,000 V	15,000 V	7,500 V
Walking across vinyl floor	12,000 V	5,000 V	3,000 V
Motions of bench worker	6,000 V	800 V	400 V
Removing DIPs from plastic tube	2,000 V	700 V	400 V
Removing DIPs from vinyl tray	11,500 V	4,000 V	2,000 V
Removing DIPs from Styrofoam	14,500 V	5,000 V	3,500 V
Removing bubble pack from PCB	26,500 V	20,000 V	7,000 V
Packing PCBs in foam-lined box	21,000 V	11,000 V	5,000 V

Packaging and transporting guidelines

Follow these grounding guidelines when packaging and transporting equipment:

- To avoid hand contact, transport products in static-safe tubes, bags, or boxes.
- Protect ESD-sensitive parts and assemblies with conductive or approved containers or packaging.
- Keep ESD-sensitive parts in their containers until the parts arrive at static-free workstations.
- Place items on a grounded surface before removing items from their containers.
- Always be properly grounded when touching a component or assembly.
- Store reusable ESD-sensitive parts from assemblies in protective packaging or non-conductive foam.
- Use transporters and conveyors made of antistatic belts and roller bushings. Be sure that mechanized equipment used for moving materials is wired to ground and that proper materials are selected to avoid static charging. When grounding is not possible, use an ionizer to dissipate electric charges.

Workstation guidelines

Follow these grounding workstation guidelines:

- Cover the workstation with approved static-shielding material.
- Use a wrist strap connected to a properly grounded work surface and use properly grounded tools and equipment.
- Use conductive field service tools, such as cutters, screwdrivers, and vacuums.
- When fixtures must directly contact dissipative surfaces, use fixtures made only of static-safe materials.
- Keep the work area free of nonconductive materials, such as ordinary plastic assembly aids and Styrofoam.
- Handle ESD-sensitive components, parts, and assemblies by the case or PCM laminate. Handle these items only at static-free workstations.
- Avoid contact with pins, leads, or circuitry.
- Turn off power and input signals before inserting or removing connectors or test equipment.

Equipment guidelines

Grounding equipment must include either a wrist strap or a foot strap at a grounded workstation.

- When seated, wear a wrist strap connected to a grounded system. Wrist straps are flexible straps with a minimum of one megohm $\pm 10\%$ resistance in the ground cords. To provide proper ground, wear a strap snugly against the skin at all times. On grounded mats with banana-plug connectors, use alligator clips to connect a wrist strap.
- When standing, use foot straps and a grounded floor mat. Foot straps (heel, toe, or boot straps) can be used at standing workstations and are compatible with most types of shoes or boots. On conductive floors or dissipative floor mats, use foot straps on both feet with a minimum of one megohm resistance between the operator and ground. To be effective, the conductive must be worn in contact with the skin.

The following grounding equipment is recommended to prevent electrostatic damage:

- Antistatic tape
- Antistatic smocks, aprons, and sleeve protectors
- Conductive bins and other assembly or soldering aids
- Nonconductive foam
- Conductive tabletop workstations with ground cords of one megohm resistance
- Static-dissipative tables or floor mats with hard ties to the ground
- Field service kits
- Static awareness labels
- Material-handling packages
- Nonconductive plastic bags, tubes, or boxes
- Metal tote boxes
- Electrostatic voltage levels and protective materials

The following table lists the shielding protection provided by antistatic bags and floor mats.

Material	Use	Voltage protection level
Antistatic plastics	Bags	1,500 V
Carbon-loaded plastic	Floor mats	7,500 V
Metallized laminate	Floor mats	5,000 V

5 Removal and replacement procedures for Customer Self-Repair parts

 **CAUTION:** The Customer Self-Repair program is not available in all locations. Installing a part not supported by the Customer Self-Repair program may void your warranty. Check your warranty to determine if Customer Self-Repair is supported in your location.

 **NOTE:** HP continually improves and changes product parts. For complete and current information on supported parts for your computer, go to <http://partsurfer.hp.com>, select your country or region, and then follow the on-screen instructions.

Component replacement procedures

 **NOTE:** Please read and follow the procedures described here to access and replace Customer Self-Repair parts successfully.

 **NOTE:** Details about your computer, including model, serial number, product key, and length of warranty, are on the service tag at the bottom of your computer.

This chapter provides removal and replacement procedures for Customer Self-Repair parts.

Battery

Description	Spare part number
4-cell, 41-Whr, 2.8-Ah Li-ion battery	919701-850
3-cell, 31-Whr, 2.8-Ah Li-ion battery	919700-850

Before disassembling the computer, follow these steps:

1. Shut down the computer. If you are unsure whether the computer is off or in Hibernation, turn the computer on, and then shut it down through the operating system.
2. Disconnect all external devices connected to the computer.
3. Disconnect the power from the computer by first unplugging the power cord from the AC outlet and then unplugging the AC adapter from the computer.

To remove the battery:

1. Position the computer upside down on a flat surface.
2. Lift the computer a few inches off the surface **(1)**.
3. While holding the computer, slide the battery lock latch **(2)** to unlock the battery.
4. While pressing on the outside edge of the battery release latch **(3)**, slide the latch **(4)** to release the battery, and then remove the battery from the computer **(5)**.



NOTE: The battery release latch automatically returns to its original position.

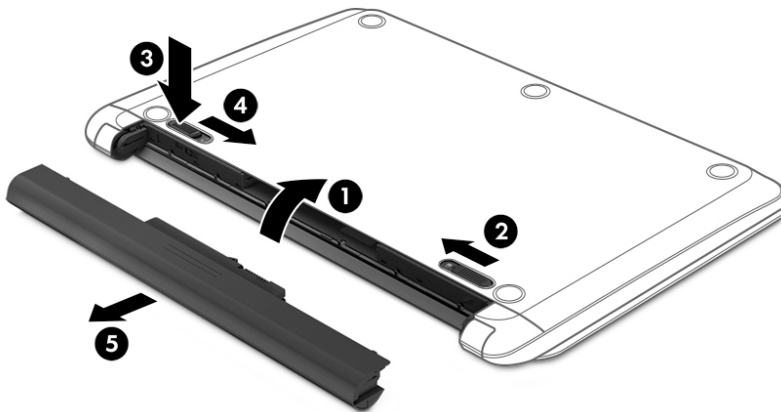

To replace the battery, **align the battery so it is parallel to the rear of the computer**, and then push the battery into the battery bay until it snaps into place **(1)**. Slide the battery lock latch **(2)** to lock the battery.

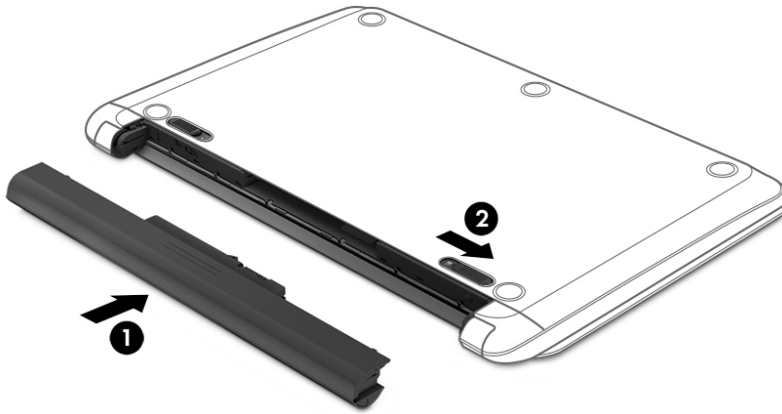

Optical drive

Description	Spare part number
Optical drive (DVD+/-RW Double-Layer SuperMulti)	920417-009
Optical drive bracket	926526-001
Optical drive bezel	
Pike silver	926505-001
Silk gold	926506-001
Smoke gray	926507-001
Marine blue	926508-001
Amethyst purple	926509-001
Pale mint	926510-001
Champagne rose	926511-001
Jet black	926512-001
Snow white	926513-001
Empress red	926514-001
Rose gold	926515-001

Before removing the optical drive, follow these steps:

1. Shut down the computer. If you are unsure whether the computer is off or in Hibernation, turn the computer on, and then shut it down through the operating system.
2. Disconnect all external devices connected to the computer.
3. Disconnect the power from the computer by first unplugging the power cord from the AC outlet and then unplugging the AC adapter from the computer.
4. Remove the battery (see [Battery on page 32](#)).

To remove the optical drive:

1. Remove the Phillips PM2.5×7.5 screw **(1)** that secures the optical drive to the computer.

2. Remove the optical drive **(2)** by sliding it out of the optical drive bay.

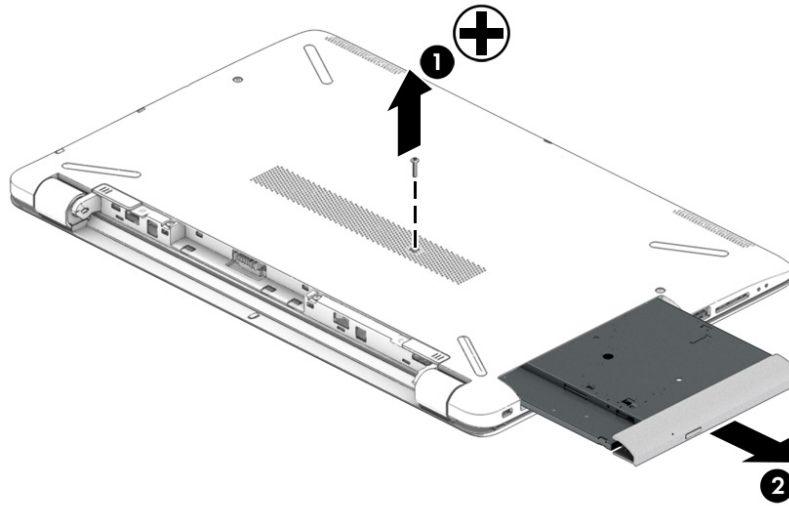

3. If it is necessary to remove the optical drive bezel, insert a paper clip into the release hole **(1)** to disengage the bezel. Press the tab **(2)** to release the bezel from the drive. Rotate the side of the bezel **(3)**, and then remove it **(4)**.

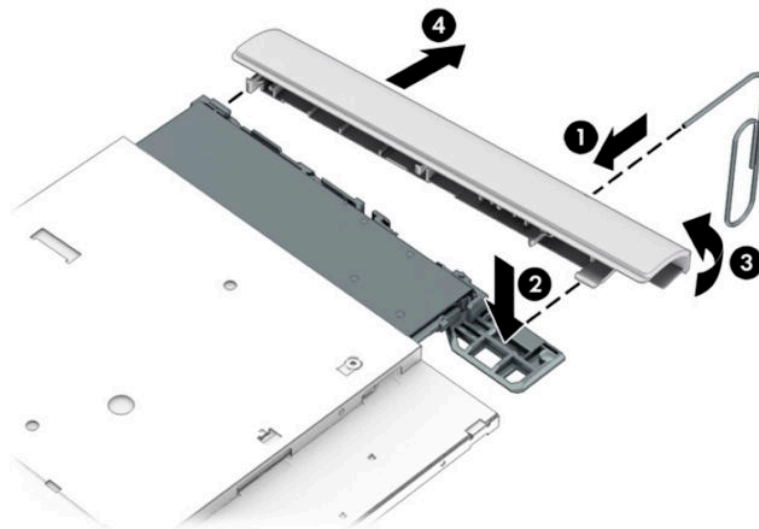

4. If it is necessary to replace the bracket on the rear of the optical drive, remove the Phillips PM2.0×2.5 screw **(1)** that secures the bracket to the drive, and then remove the bracket **(2)**.

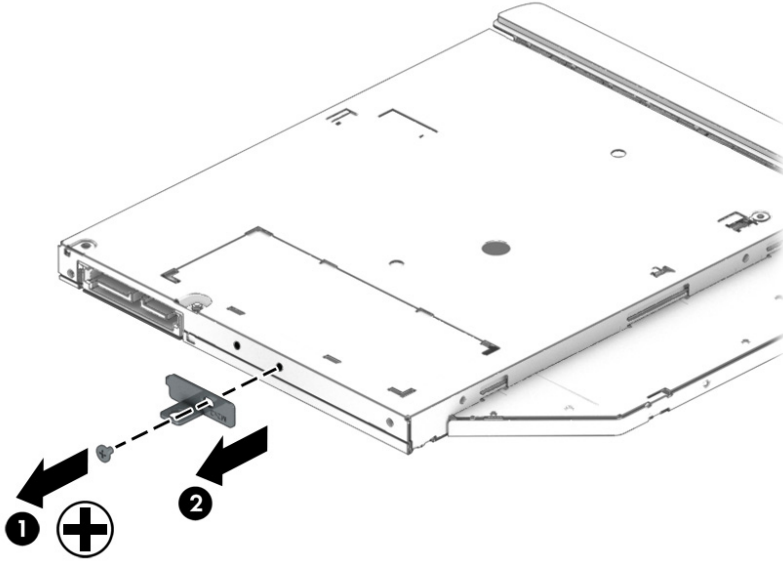

Reverse this procedure to reassemble and install the optical drive.

6 Removal and replacement procedures for Authorized Service Provider parts

 **CAUTION:** Components described in this chapter should only be accessed by an authorized service provider. Accessing these parts can damage the computer or void the warranty.

 **NOTE:** HP continually improves and changes product parts. For complete and current information on supported parts for your computer, go to <http://partsurfer.hp.com>, select your country or region, and then follow the on-screen instructions.

Component replacement procedures

 **NOTE:** Details about your computer, including model, serial number, product key, and length of warranty, are on the service tag at the bottom of your computer.

This chapter provides removal and replacement procedures for Authorized Service Provider only parts.

There are as many as 58 screws that must be removed, replaced, or loosened when servicing Authorized Service Provider only parts. Make special note of each screw size and location during removal and replacement.

Display subcomponents (bezel, webcam, panel)

This section describes removing display subcomponents that do not require that you remove the entire display assembly from the computer. You can remove the display bezel, webcam/microphone module, and display panel while the display assembly is still attached to the computer.

To remove the remaining display subcomponents, you must remove the entire display assembly from the computer. See [Display assembly on page 67](#) for more information about removing the display assembly in its entirety.

Description	Spare part number
Raw display panel	
FHD, anti glare, non-touch	798926-011
HD, Touch On Panel (TOP)	851049-003
HD+, BrightView, non-touch	851051-005
HD+, anti glare, non-touch	910136-003
Display bezel	
	926504-001
Webcam/microphone module	
HD	919471-003
VGA	919472-003

Before removing display subcomponents while the display assembly is still attached to the computer, follow these steps:

1. Shut down the computer. If you are unsure whether the computer is off or in Hibernation, turn the computer on, and then shut it down through the operating system.
2. Disconnect all external devices connected to the computer.
3. Disconnect the power from the computer by first unplugging the power cord from the AC outlet and then unplugging the AC adapter from the computer.
4. Remove the battery (see [Battery on page 32](#)).

To remove the display bezel, webcam/microphone module, and raw display panel:

1. Position the computer upright with the front toward you, and then open it.
2. Flex the inside of the top edge **(1)**, left **(2)** and right sides **(3)**, and the inside of the bottom edge **(4)** of the display bezel until the bezel disengages from the display enclosure.
3. Remove the display bezel **(5)**.



4. To remove the webcam/microphone module:
 - a. Position the display assembly with the top edge toward you.
 - b. Lift to disengage the adhesive that secures the webcam/microphone module to the display **(1)**.

- c. Disconnect the cable **(2)** from the module.

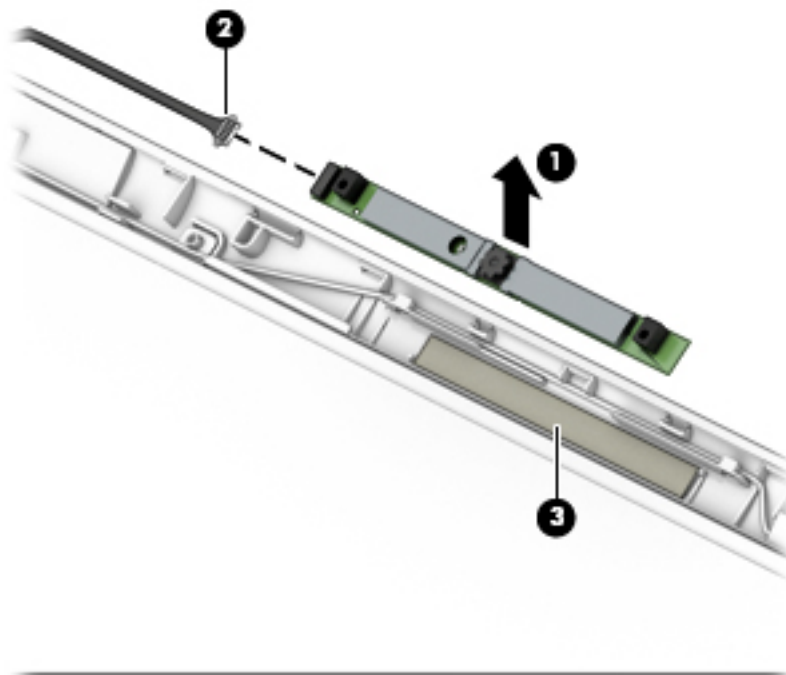

- 5. To remove the display panel:

- a. Remove the four Phillips PM2.0×3.0 screws **(1)** that secure the display panel to the enclosure.



- b. Rotate the display panel onto the keyboard **(1)** to gain access to the display cable connection on the back of the panel.
- c. On the back of the display panel, release the adhesive strip that secures the display panel cable to the display panel **(2)**, and then disconnect the cable **(3)**.

- d. Remove the display panel from the computer.

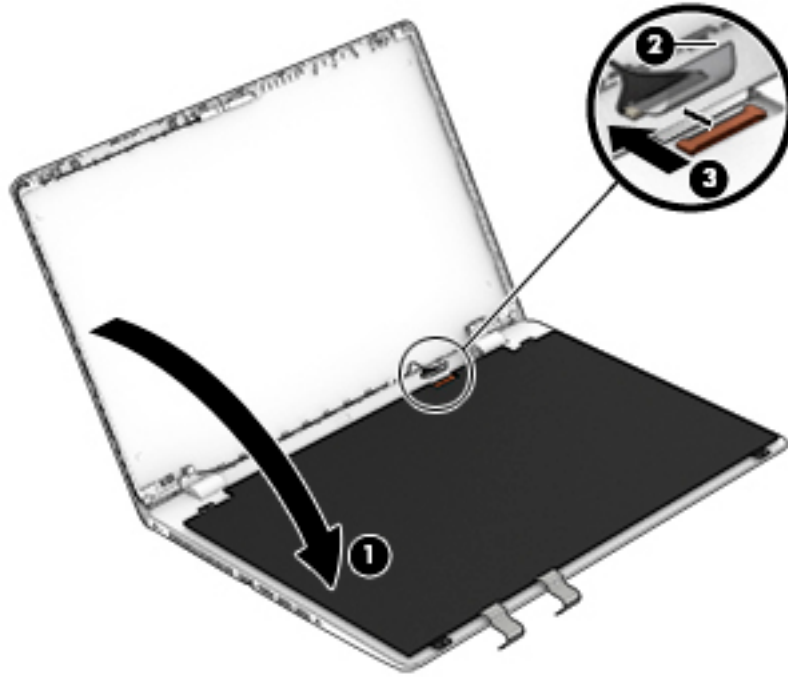

Reverse this procedure to reassemble and install the display bezel, webcam/microphone module, and display panel.

Bottom cover

Description	Spare part number
Bottom cover for use in models of the following colors:	
Pike silver	926493-001
Silk gold	926494-001
Smoke gray	926495-001
Marine blue	926496-001
Amethyst purple	926497-001
Pale mint	926498-001
Champagne rose	926499-001
Jet black	926500-001
Snow white	926501-001
Empress red	926502-001
Rose gold	926503-001

Before removing the bottom cover, follow these steps:

1. Shut down the computer. If you are unsure whether the computer is off or in Hibernation, turn the computer on, and then shut it down through the operating system.
2. Disconnect all external devices connected to the computer.
3. Disconnect the power from the computer by first unplugging the power cord from the AC outlet and then unplugging the AC adapter from the computer.
4. Remove the battery (see [Battery on page 32](#)).
5. Remove the optical drive (see [Optical drive on page 34](#)).

To remove the bottom cover:

1. Position the computer upside down with the front toward you.
2. Remove the four rubber feet **(1)**.
3. Remove the nine Phillips PM PM2.5×7.5 screws **(2)** that secure the bottom cover to the computer.

4. Remove the two Phillips PM PM2.5×14.0 screws (3) that secure the bottom cover to the computer.

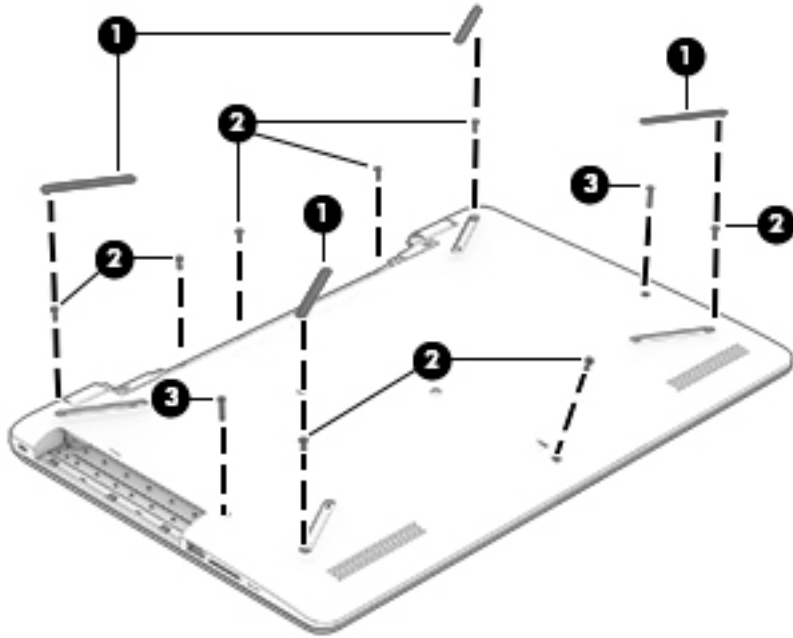

5. Start at the front of the computer and pry to separate the bottom cover from the computer (1). Work your way around prying to disengage the bottom cover from the computer (2), and then remove the cover (3).

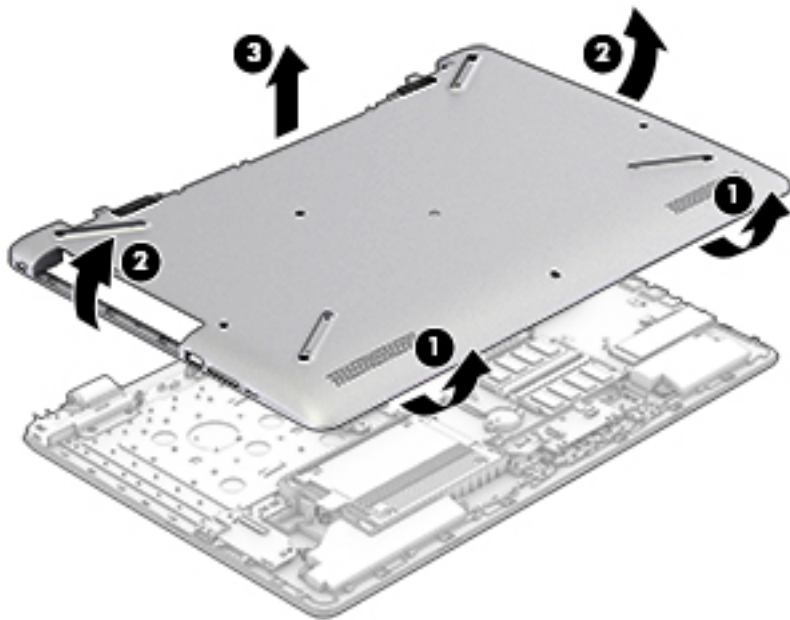

Reverse this procedure to install the bottom cover.

Hard drive



NOTE: The hard drive spare part kit does not include the hard drive cover.

Description	Spare part number
2-TB, 5400-rpm, 2.5 inch	912487-855
1-TB, 5400-rpm, 2.5 inch	676423-855
500-GB, 5400-rpm, 2.5 inch	683839-855
Hard drive holder	905974-001

Before removing the hard drive, follow these steps:

1. Shut down the computer. If you are unsure whether the computer is off or in Hibernation, turn the computer on, and then shut it down through the operating system.
2. Disconnect all external devices connected to the computer.
3. Disconnect the power from the computer by first unplugging the power cord from the AC outlet and then unplugging the AC adapter from the computer.
4. Remove the battery (see [Battery on page 32](#)).
5. Remove the optical drive (see [Optical drive on page 34](#)).
6. Remove the bottom cover (see [Bottom cover on page 41](#)).

To remove the hard drive:

1. Disconnect the USB board cable from the system board and remove it from atop the hard drive.

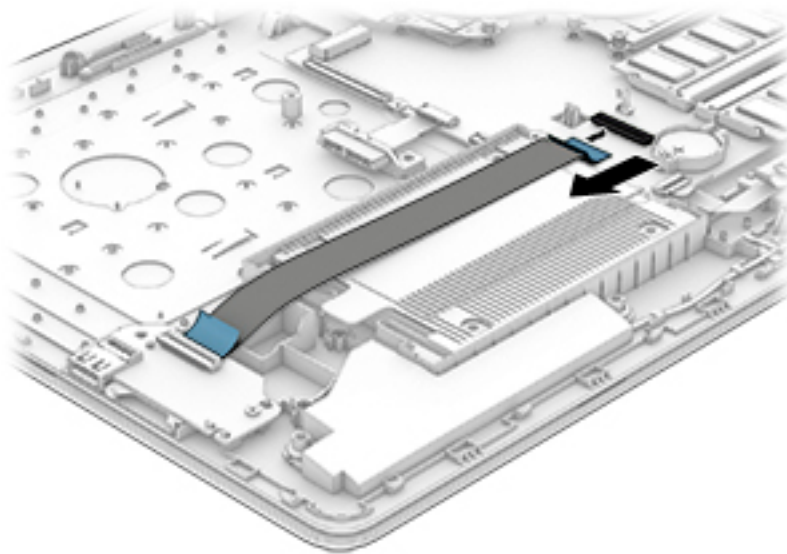

2. Lift the hard drive up, and then pull it away from the connector and remove it from the computer.

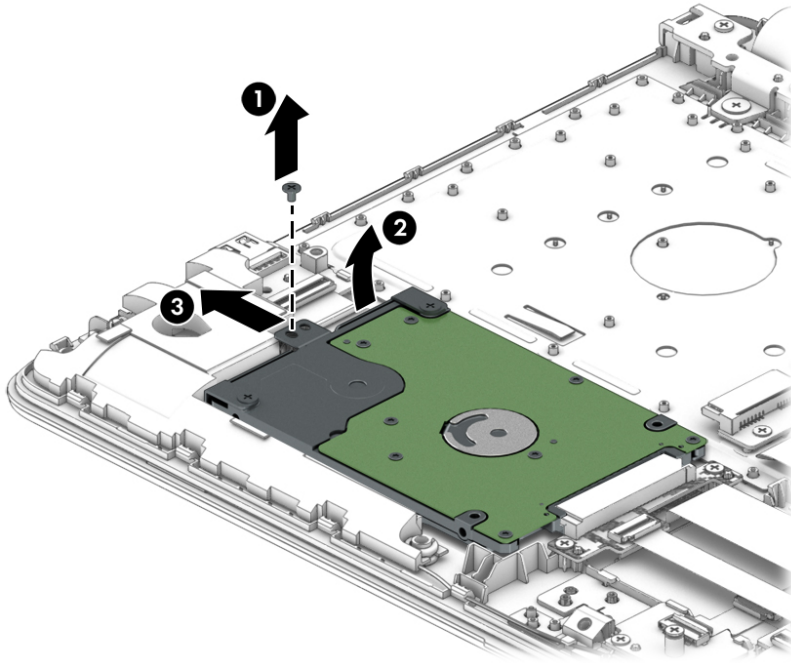

3. To disassemble the hard drive, pull the sides of the cover up and away from the hard drive (1), and then remove the cover from the hard drive (2).

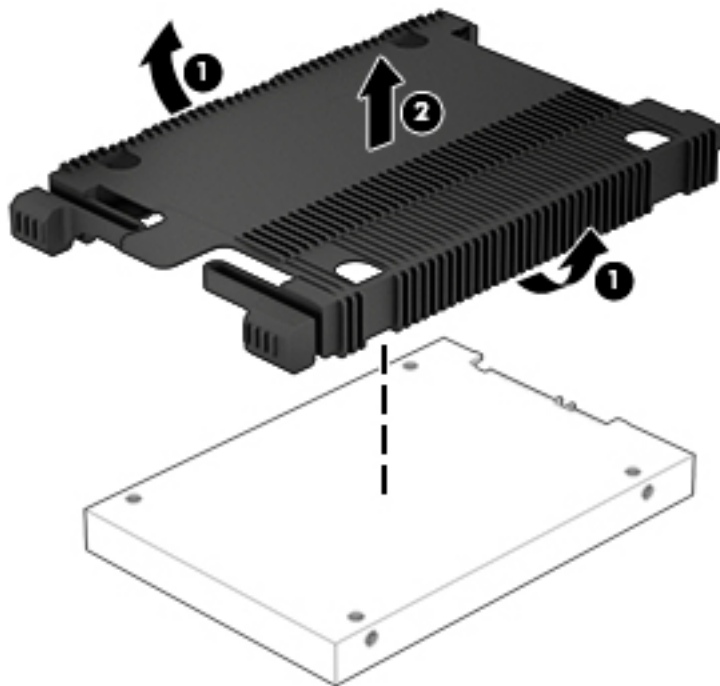

Reverse this procedure to reassemble and install the hard drive.

WLAN module

Description	Spare part number
Intel Dual Band Wireless-AC 7265 802.11 AC 2x2 WiFi + BT 4.2 Combo Adapter (non-vPro)	793840-005
Realtek RTL8723DE 802.11 bgn 1x1 WiFi + BT 4.2 Combo Adapter	927230-855
Realtek RTL 8188EE 802.11 bgn 1x1 WiFi Adapter	927235-855
Intel Dual Band Wireless-AC 3168 802.11 ac 1x1 WiFi + BT 4.2 Combo	863934-855

 **CAUTION:** To prevent an unresponsive system, replace the wireless module only with a wireless module authorized for use in the computer by the governmental agency that regulates wireless devices in your country or region. If you replace the module and then receive a warning message, remove the module to restore device functionality, and then contact support.

Before removing the WLAN module, follow these steps:

1. Shut down the computer. If you are unsure whether the computer is off or in Hibernation, turn the computer on, and then shut it down through the operating system.
2. Disconnect all external devices connected to the computer.
3. Disconnect the power from the computer by first unplugging the power cord from the AC outlet and then unplugging the AC adapter from the computer.
4. Remove the battery (see [Battery on page 32](#)).
5. Remove the optical drive (see [Optical drive on page 34](#)).
6. Remove the bottom cover (see [Bottom cover on page 41](#)).

To remove the WLAN module:

1. Disconnect the WLAN antenna cables **(1)** from the terminals on the WLAN module.



NOTE: The #1 WLAN antenna cable is connected to the WLAN module Main terminal. The #2 WLAN antenna cable is connected to the WLAN module Aux terminal.

2. Remove the Phillips PM2.0×3.0 screw **(2)** that secures the WLAN module to the system board. (The WLAN module tilts up.)

3. Remove the WLAN module by pulling the module away from the slot at an angle (3).

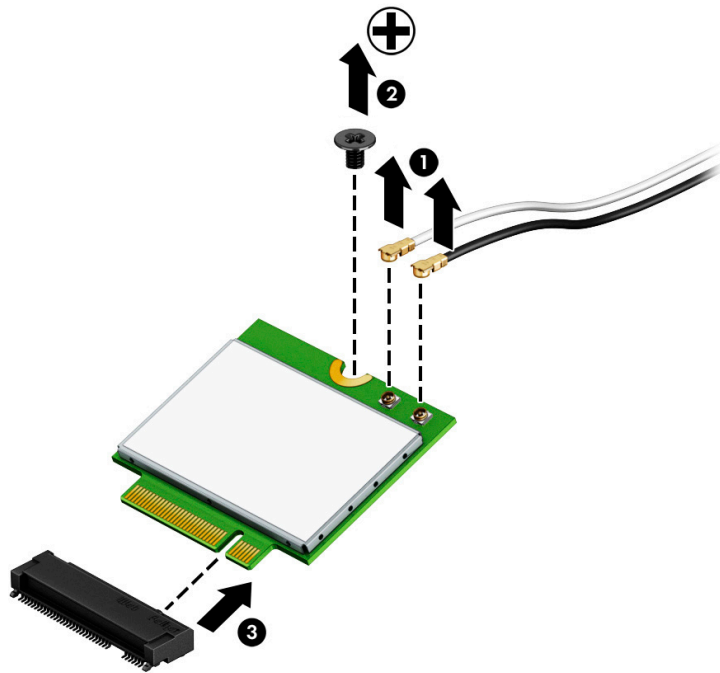

 **NOTE:** If the WLAN antennas are not connected to the terminals on the WLAN module, the protective sleeves must be installed on the antenna connectors, as shown in the following illustration.

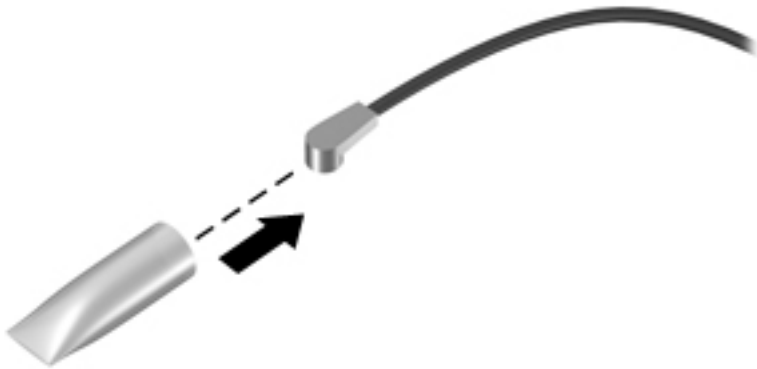

Reverse this procedure to install the WLAN module.

RTC battery

Description	Spare part number
RTC battery	926546-001

Before removing the RTC battery, follow these steps:

1. Shut down the computer. If you are unsure whether the computer is off or in Hibernation, turn the computer on, and then shut it down through the operating system.
2. Disconnect all external devices connected to the computer.
3. Disconnect the power from the computer by first unplugging the power cord from the AC outlet and then unplugging the AC adapter from the computer.
4. Remove the battery (see [Battery on page 32](#)).
5. Remove the optical drive (see [Optical drive on page 34](#)).
6. Remove the bottom cover (see [Bottom cover on page 41](#)).

To remove the RTC battery:

- ▲ Using a thin tool or screwdriver, disengage the battery from the socket **(1)**, and then remove the battery **(2)**.

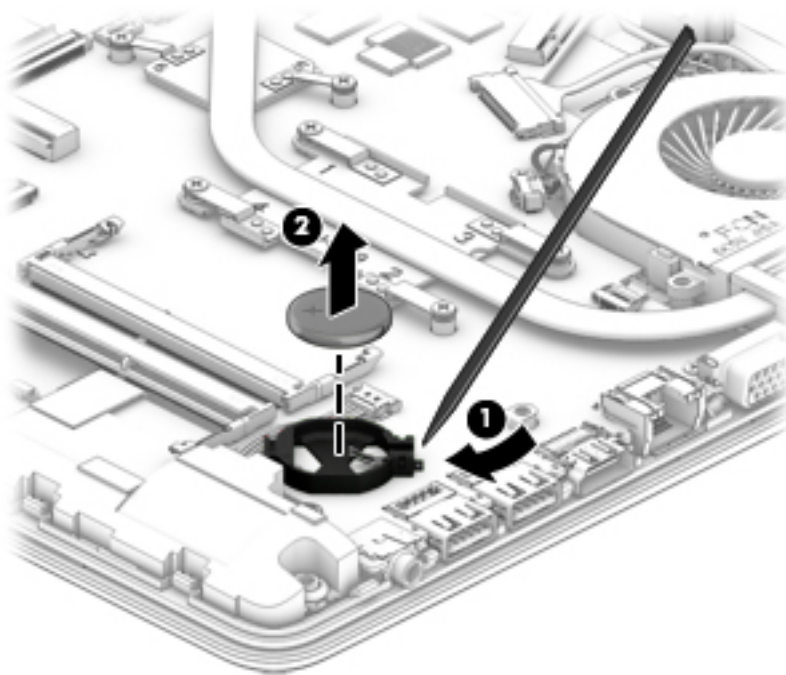

Reverse this procedure to install the RTC battery.

Memory module

Description	Spare part number
Memory module (PC3L-1600)	
For use in models with Intel Pentium and Celeron processors	
8-GB	693374-005
4-GB	691740-005
Memory module (PC4-2400)	
For use in models with Intel Core processors	
8-GB	862398-855
4-GB	862397-855
2-GB	864271-855

Before removing a memory module, follow these steps:

1. Shut down the computer. If you are unsure whether the computer is off or in Hibernation, turn the computer on, and then shut it down through the operating system.
2. Disconnect all external devices connected to the computer.
3. Disconnect the power from the computer by first unplugging the power cord from the AC outlet and then unplugging the AC adapter from the computer.
4. Remove the battery (see [Battery on page 32](#)).
5. Remove the optical drive (see [Optical drive on page 34](#)).
6. Remove the bottom cover (see [Bottom cover on page 41](#)).

To remove a memory module:

1. Spread the retaining tabs **(1)** on each side of the memory module slot to release the memory module. (The memory module tilts up.)

2. Remove the memory module (2) by pulling it away from the slot at an angle.

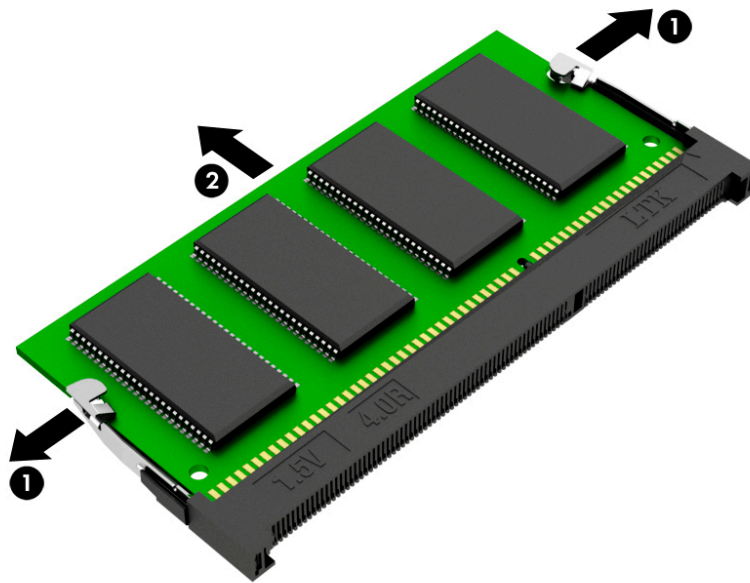

Reverse this procedure to install a memory module.

Solid-state drive

Description	Spare part number
Value SSD:	
256 GB	865902-014
128 GB	827560-045
TLC:	
512 GB	763008-016
256 GB	760615-044
128 GB	759848-025

Before removing the solid-state drive, follow these steps:

1. Turn off the computer. If you are unsure whether the computer is off or in Hibernation, turn the computer on, and then shut it down through the operating system.
2. Disconnect the power from the computer by unplugging the power cord from the computer.
3. Remove the battery (see [Battery on page 32](#)).
4. Remove the optical drive (see [Optical drive on page 34](#)).
5. Remove the bottom cover (see [Bottom cover on page 41](#)).

Remove the solid-state drive:

1. Remove the Phillips PM2.0×2.0 screw **(1)** that secures the drive to the system board.
2. Remove the drive **(2)** by pulling it away from the connector.

 **NOTE:** Solid-state drives are designed with notches to prevent incorrect insertion.

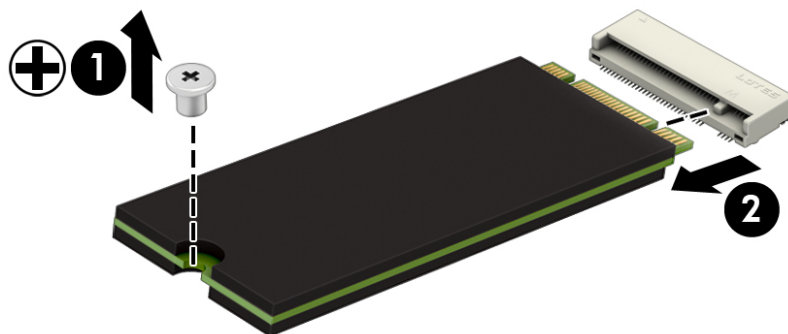

Reverse this procedure to install the solid-state drive.

Solid-state drive holder and board

Description	Spare part number
Solid-state drive holder	858260-001
Solid-state drive board	856614-001

Before removing the solid-state drive holder and board, follow these steps:

1. Shut down the computer. If you are unsure whether the computer is off or in Hibernation, turn the computer on, and then shut it down through the operating system.
2. Disconnect all external devices connected to the computer.
3. Disconnect the power from the computer by first unplugging the power cord from the AC outlet and then unplugging the AC adapter from the computer.
4. Remove the battery (see [Battery on page 32](#)).
5. Remove the optical drive (see [Optical drive on page 34](#)).
6. Remove the bottom cover (see [Bottom cover on page 41](#)).
7. Remove the solid-state drive (see [Solid-state drive on page 50](#)).

To remove the solid-state drive holder and board:

1. Remove the Phillips PM2.0×4.5 screw **(1)** that secures the solid-state drive holder to the computer.
2. Pull the board away from the connector on system board, and then remove the solid-state drive holder and board assembly **(2)**.

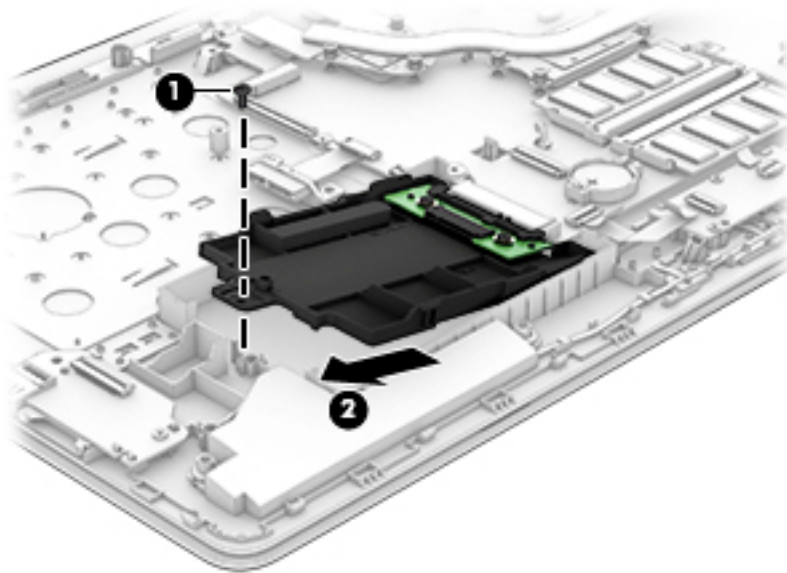

3. To remove the solid-state drive board from the holder, remove the two Phillips PM2.0×4.0 screws **(1)** that secure the board to the holder.

4. Lift the board out of the holder (2).

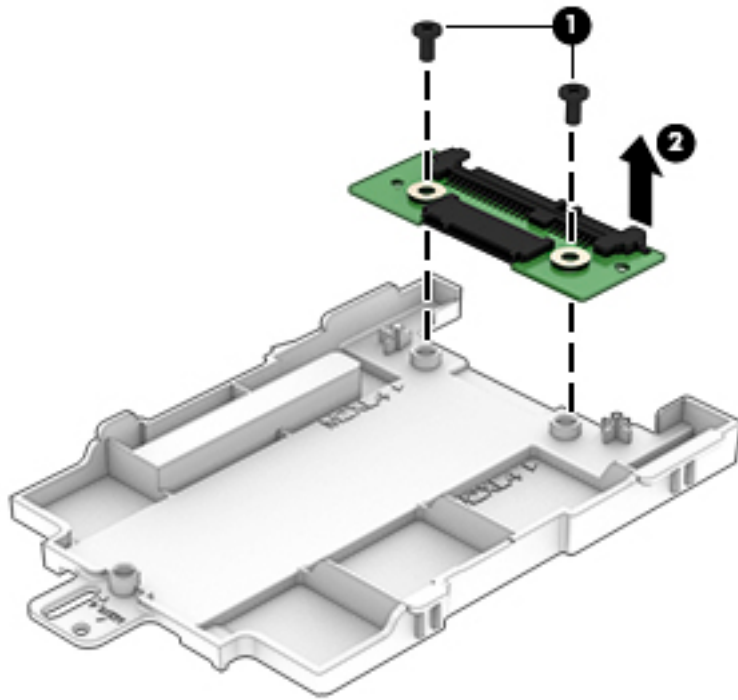

Reverse this procedure to install the solid-state drive holder and board.

Optical drive connector

Description	Spare part number
Optical drive connector	926521-001

Before removing the optical drive connector, follow these steps:

1. Shut down the computer. If you are unsure whether the computer is off or in Hibernation, turn the computer on, and then shut it down through the operating system.
2. Disconnect all external devices connected to the computer.
3. Disconnect the power from the computer by first unplugging the power cord from the AC outlet and then unplugging the AC adapter from the computer.
4. Remove the battery (see [Battery on page 32](#)).
5. Remove the optical drive (see [Optical drive on page 34](#)).
6. Remove the bottom cover (see [Bottom cover on page 41](#)).

To remove the optical drive connector:

1. Disconnect the optical drive connector cable from the system board **(1)**.
2. Remove the Phillips PM2.0×4.0 screw **(2)** that secures the optical drive connector to the computer.
3. Remove the optical drive connector and cable **(3)**.

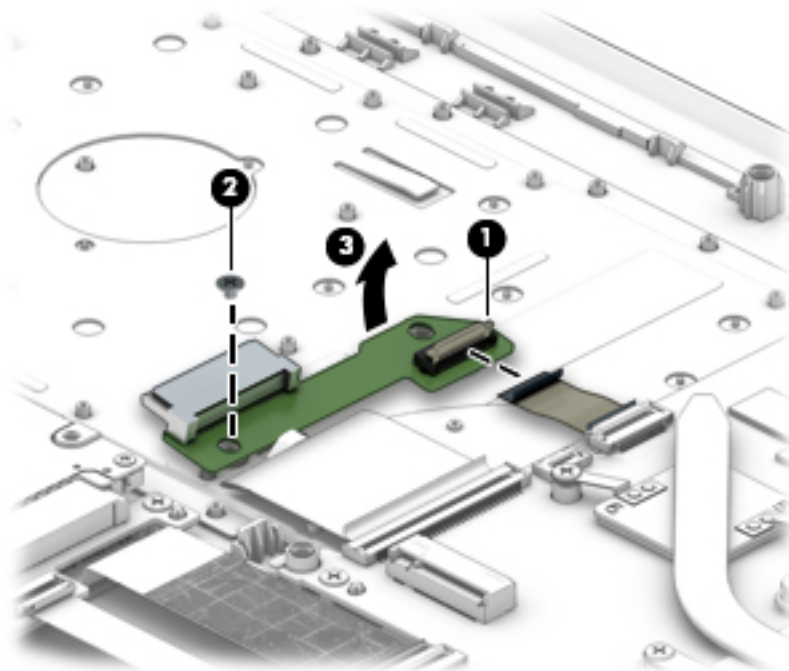

Reverse this procedure to install the optical drive connector.

TouchPad click board

Description	Spare part number
TouchPad click board	926530-001
TouchPad click board cable	928882-001
NOTE: This cable connects from the TouchPad click board to the system board.	
TouchPad cable	926518-001
NOTE: This cable connects from the TouchPad board to the TouchPad click board.	

Before removing the TouchPad click board, follow these steps:

1. Shut down the computer. If you are unsure whether the computer is off or in Hibernation, turn the computer on, and then shut it down through the operating system.
2. Disconnect all external devices connected to the computer.
3. Disconnect the power from the computer by first unplugging the power cord from the AC outlet and then unplugging the AC adapter from the computer.
4. Remove the battery (see [Battery on page 32](#)).
5. Remove the optical drive (see [Optical drive on page 34](#)).
6. Remove the bottom cover (see [Bottom cover on page 41](#)).

To remove the TouchPad click board:

1. Disconnect the TouchPad cable from the TouchPad board **(1)** and the system board cable from the TouchPad click board **(2)**.
2. Remove the three Phillips PM2.0×4.0 screws **(3)** that secure the TouchPad click board to the computer.
3. Remove the board from the computer **(4)**.

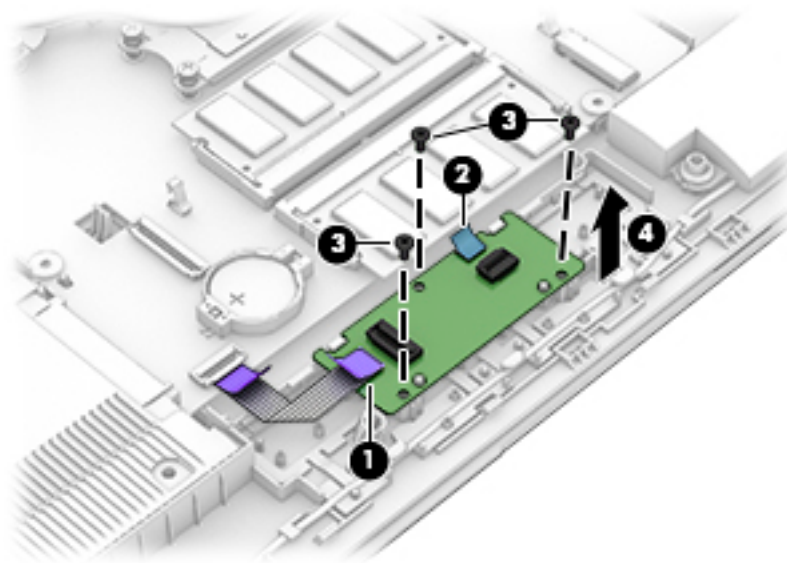

Reverse this procedure to install the TouchPad click board.

TouchPad board

Description	Spare part number
TouchPad board	926531-001
TouchPad cable	926518-001

NOTE: This cable connects from the TouchPad board to the TouchPad click board.

Before removing the TouchPad board, follow these steps:

1. Shut down the computer. If you are unsure whether the computer is off or in Hibernation, turn the computer on, and then shut it down through the operating system.
2. Disconnect all external devices connected to the computer.
3. Disconnect the power from the computer by first unplugging the power cord from the AC outlet and then unplugging the AC adapter from the computer.
4. Remove the battery (see [Battery on page 32](#)).
5. Remove the optical drive (see [Optical drive on page 34](#)).
6. Remove the bottom cover (see [Bottom cover on page 41](#)).

To remove the TouchPad board:

1. Disconnect the TouchPad cable from the TouchPad board **(1)**.
2. Lift the conductive tape **(2)**, and then remove the TouchPad board from the computer **(3)**.

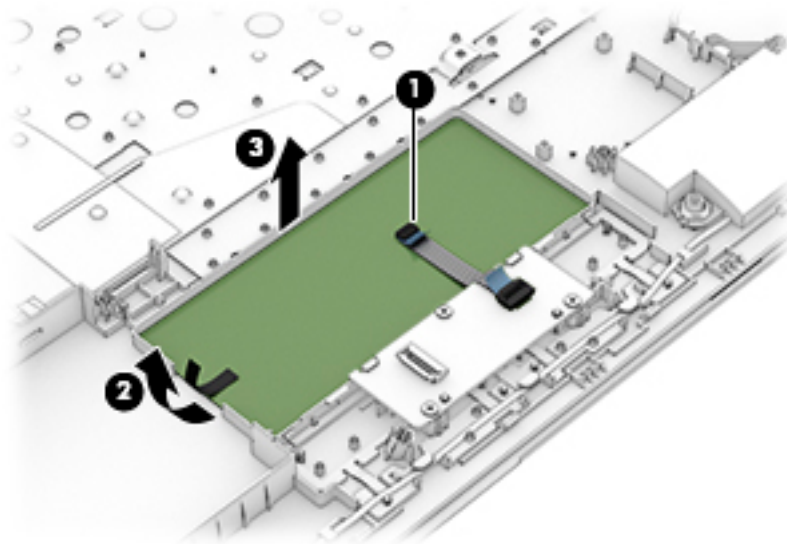

Reverse this procedure to install the TouchPad board.

USB board

Description	Spare part number
USB board	926528-001
USB board cable	926516-001

Before removing the USB board, follow these steps:

1. Shut down the computer. If you are unsure whether the computer is off or in Hibernation, turn the computer on, and then shut it down through the operating system.
2. Disconnect all external devices connected to the computer.
3. Disconnect the power from the computer by first unplugging the power cord from the AC outlet and then unplugging the AC adapter from the computer.
4. Remove the battery (see [Battery on page 32](#)).
5. Remove the optical drive (see [Optical drive on page 34](#)).
6. Remove the bottom cover (see [Bottom cover on page 41](#)).

To remove the USB board:

1. Disconnect the cable from the USB board **(1)**
2. Remove the Phillips PM2.0×4.0 screw **(2)** that secures the USB board to the computer.
3. Remove the USB board from the computer **(3)**.

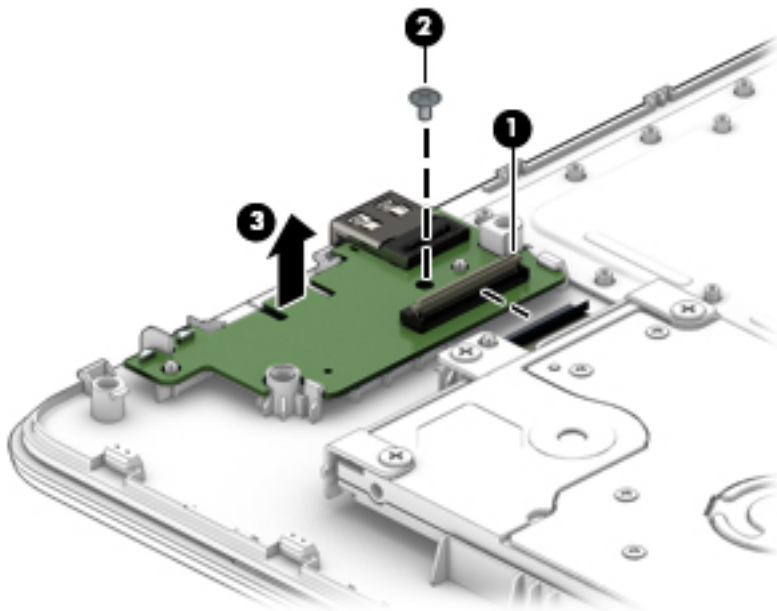

Reverse this procedure to install the USB board.

Speakers

Description	Spare part number
Speakers (includes left and right speakers and cable)	926558-001

Before removing the speakers, follow these steps:

1. Shut down the computer. If you are unsure whether the computer is off or in Hibernation, turn the computer on, and then shut it down through the operating system.
2. Disconnect all external devices connected to the computer.
3. Disconnect the power from the computer by first unplugging the power cord from the AC outlet and then unplugging the AC adapter from the computer.
4. Remove the battery (see [Battery on page 32](#)).
5. Remove the optical drive (see [Optical drive on page 34](#)).
6. Remove the bottom cover (see [Bottom cover on page 41](#)).

To remove the speakers:

1. Disconnect the speaker cable from the system board (1).
2. Remove the cable from the routing path (2).
3. Lift the speakers out of the computer (3).

 **NOTE:** When installing the speakers, make sure the rubber grommets (4) that secure the speakers are correctly installed.

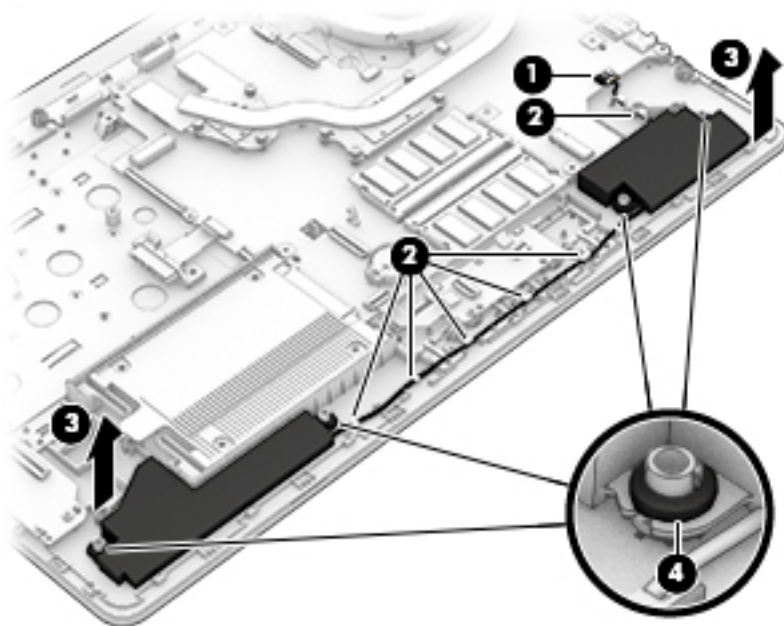

Reverse this procedure to install the speakers.

Fan

Description	Spare part number
Fan	926724-001

Before removing the fan, follow these steps:

1. Shut down the computer. If you are unsure whether the computer is off or in Hibernation, turn the computer on, and then shut it down through the operating system.
2. Disconnect all external devices connected to the computer.
3. Disconnect the power from the computer by first unplugging the power cord from the AC outlet and then unplugging the AC adapter from the computer.
4. Remove the battery (see [Battery on page 32](#)).
5. Remove the optical drive (see [Optical drive on page 34](#)).
6. Remove the bottom cover (see [Bottom cover on page 41](#)).

To remove the fan:

1. Disconnect the fan cable from the system board **(1)**.
2. Remove the Phillips PM2.0×4.0 screw **(2)** that secures the fan to the computer.
3. Lift the fan out of the computer **(3)**.

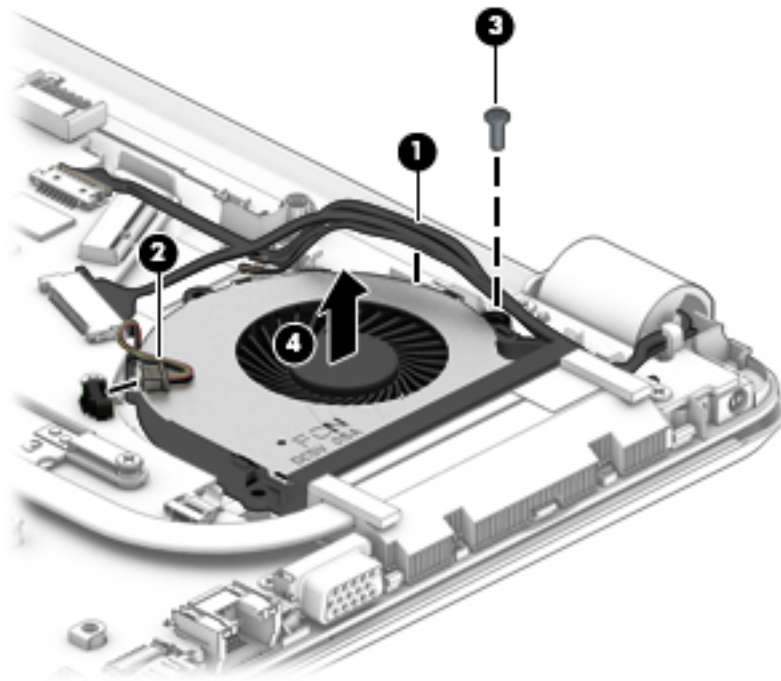

Reverse this procedure to install the fan.

Heat sink assembly



NOTE: The heat sink assembly spare part kit includes replacement thermal materials.

Description	Spare part number
Heat sink assembly for use in models without a fan and with Intel Pentium N4200 or Intel Celeron N3350 processors and UMA graphics	936457-001
Heat sink assembly for use in models with Intel Pentium or Celeron processors and discrete graphics	926525-001
Heat sink assembly for use in models with Intel Core processors and discrete graphics	926523-001
Heat sink assembly for use in models with a fan and with Intel Core processors and UMA graphics	926522-001
Heat sink assembly for use in models without a fan and with Intel Pentium N3710 or Intel Celeron N3060 processors and UMA graphics	926524-001



NOTE: To properly ventilate the computer, allow at least **7.6 cm** (3.0 in) of clearance on the left side of the computer. The computer uses an electric fan for ventilation. The fan is controlled by a temperature sensor and is designed to turn on automatically when high temperature conditions exist. These conditions are affected by high external temperatures, system power consumption, power management/battery conservation configurations, battery fast charging, and software requirements. Exhaust air is displaced through the ventilation grill located on the left side of the computer.

Before removing the heat sink assembly, follow these steps:

1. Shut down the computer. If you are unsure whether the computer is off or in Hibernation, turn the computer on, and then shut it down through the operating system.
2. Disconnect all external devices connected to the computer.
3. Disconnect the power from the computer by first unplugging the power cord from the AC outlet and then unplugging the AC adapter from the computer.
4. Remove the battery (see [Battery on page 32](#)).
5. Remove the optical drive (see [Optical drive on page 34](#)).
6. Remove the bottom cover (see [Bottom cover on page 41](#)).

To remove the heat sink assembly:

1. If you have a model with discrete graphics:
 - a. In the order indicated on the heat sink, loosen the seven Phillips screws **(1)** that secure the heat sink to the system board.

- b. Remove the heat sink **(2)** from the system board.

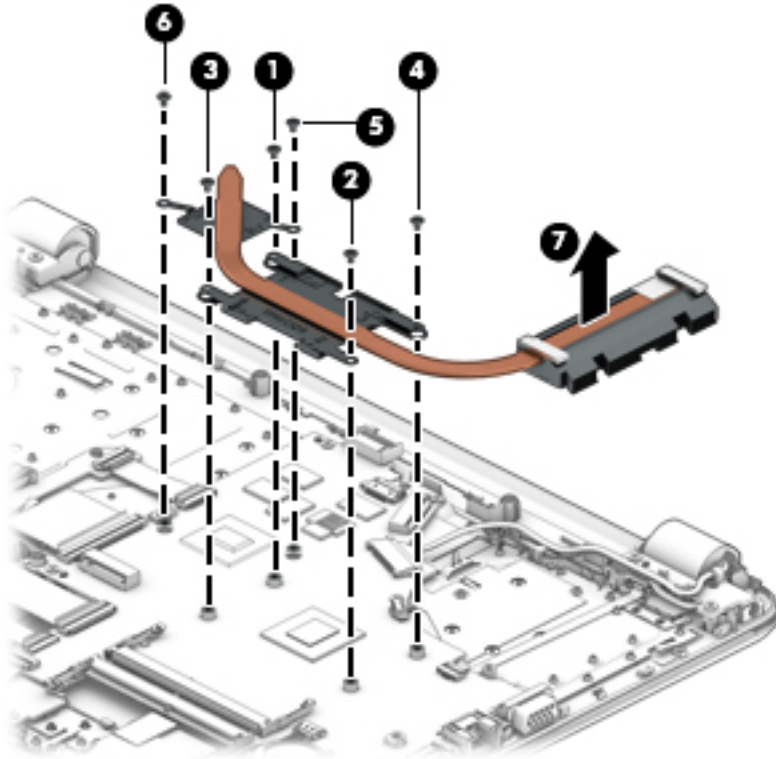

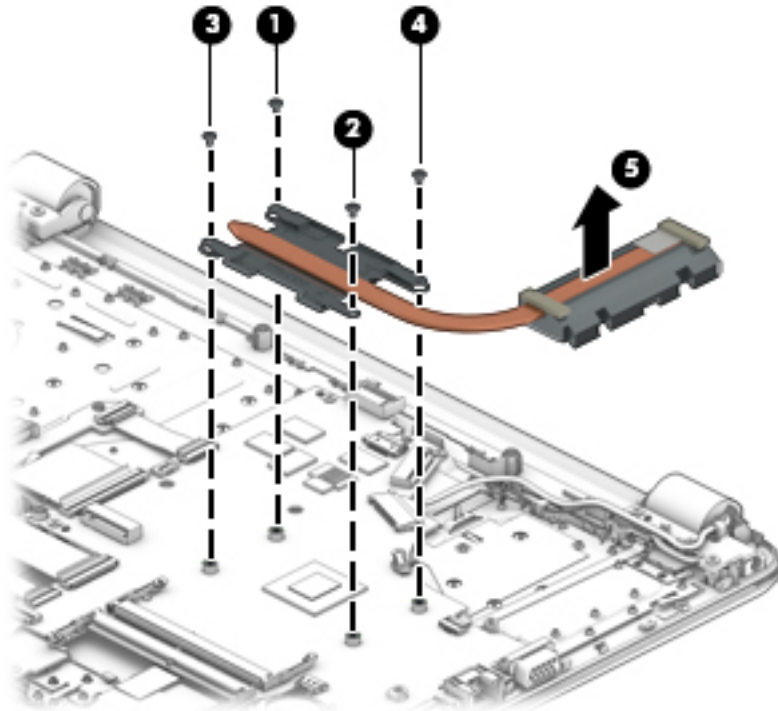

- 2. If you have a model with UMA graphics and fan:
 - a. In the order indicated on the heat sink, loosen the four Phillips screws **(1)** that secure the heat sink to the system board.

- Remove the heat sink **(2)** from the system board.

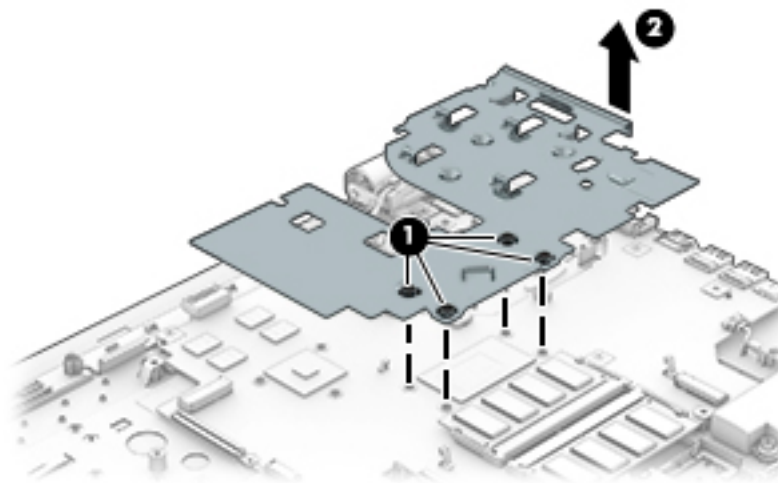

- In the order indicated on the heat sink, loosen the four Phillips screws **(1)** that secure the heat sink to the system board.
 - Remove the heat sink **(2)** from the system board.



 **NOTE:** The thermal material must be thoroughly cleaned from the surfaces of the heat sink and the system board components each time the heat sink is removed. Replacement thermal material is included with the heat sink, processor, and system board spare part kits.

The following illustrations show the replacement thermal material locations.

- **Discrete graphics:** Thermal paste is used on the heat sink (1) (3) and associated system board components (2) (4).

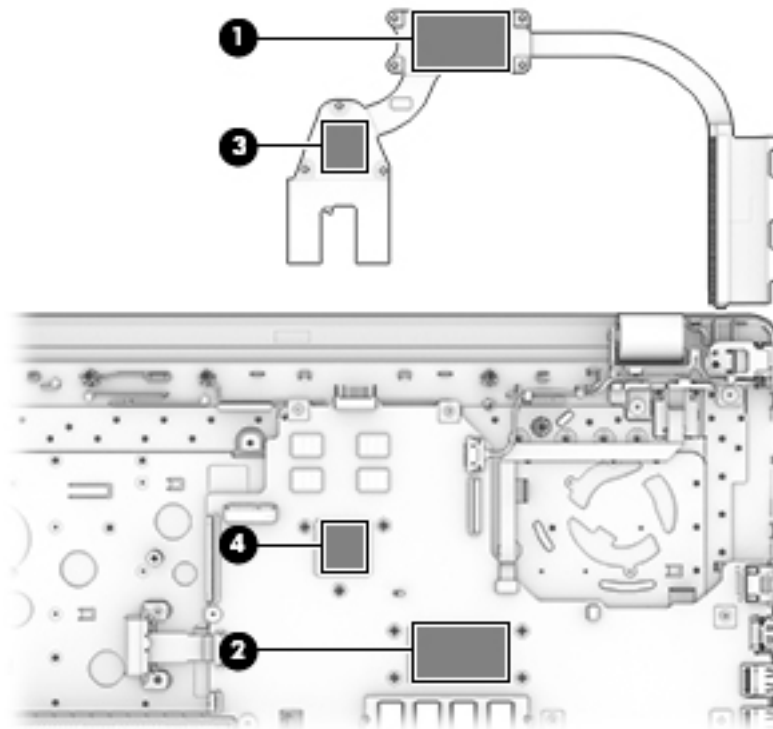

- **UMA graphics on models with fan:** Thermal paste is used on the heat sink (1) and associated system board component (2).

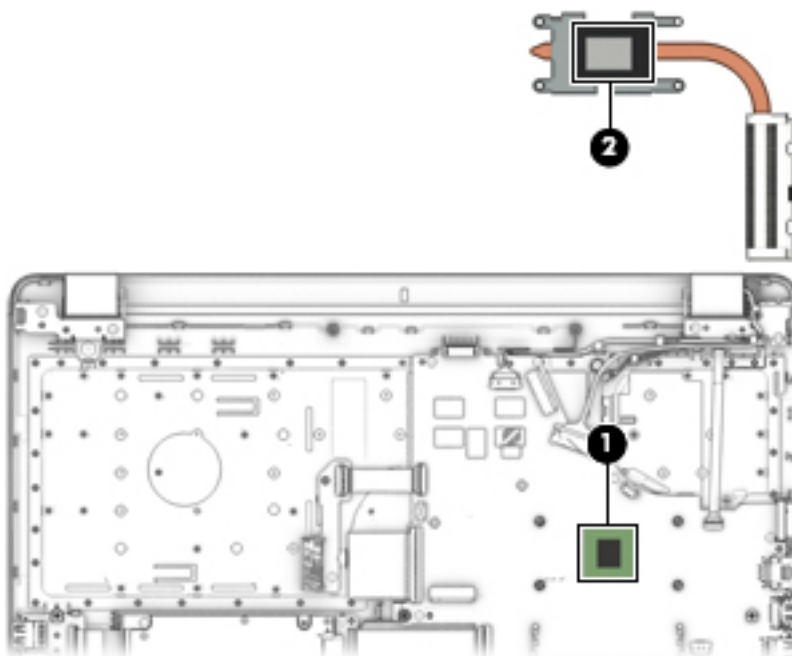

- **UMA graphics on models without fan:** Thermal paste is used on the heat sink **(1)** and associated system board component **(2)**.

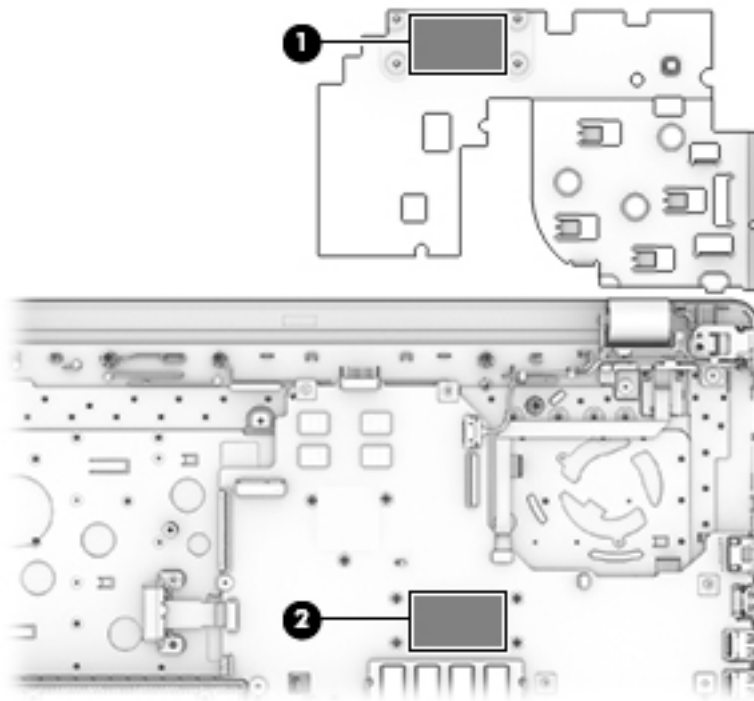

Reverse this procedure to reassemble and install the heat sink assembly.

System board



NOTE: The system board spare part kit includes replacement thermal materials.

Description	Spare part number
System board (includes replacement thermal materials):	
All system boards use the following part numbers:	
xxxxxx-001: Windows 7 or non-Windows operating system	
xxxxxx-601: Windows 10	
For use in models with discrete graphics:	
• Intel Core i7-7500U processor and 4 GB of dedicated video memory	925618-xxx
• Intel Core i7-7500U processor and 2 GB of dedicated video memory	925619-xxx
• Intel Core i7-8250U processor and 2 GB of dedicated video memory	939591-xxx
• Intel Core i5-7200U processor and 2 GB of dedicated video memory (M1-70)	925616-xxx
• Intel Core i5-7200U processor and 2 GB of dedicated video memory (M1-30)	925617-xxx
• Intel Core i3-6006U processor and 2 GB of dedicated video memory	925620-xxx
• Intel Pentium N4200 processor and 2 GB of dedicated video memory	939590-xxx
• Intel Pentium N3710 processor and 2 GB of dedicated video memory	925627-xxx
For use in models with UMA graphics:	
• Intel Core i7-7500U processor	925623-xxx
• Intel Core i5-7200U processor	925624-xxx
• Intel Core i3-7100U processor	925625-xxx
• Intel Core i3-6006U processor	925626-xxx
• Intel Pentium N4200 processor	939588-xxx
• Intel Pentium N3710 processor	925621-xxx
• Intel Celeron N3350 processor	939589-xxx
• Intel Celeron N3060 processor	925622-xxx

Before removing the system board, follow these steps:

1. Shut down the computer. If you are unsure whether the computer is off or in Hibernation, turn the computer on, and then shut it down through the operating system.
2. Disconnect all external devices connected to the computer.
3. Disconnect the power from the computer by first unplugging the power cord from the AC outlet and then unplugging the AC adapter from the computer.
4. Remove the battery (see [Battery on page 32](#)).
5. Remove the optical drive (see [Optical drive on page 34](#)).

6. Remove the bottom cover (see [Bottom cover on page 41](#)).
7. Remove the fan (see [Fan on page 58](#)).

 **NOTE:** When replacing the system board, be sure that the following components are removed from the defective system board and installed on the replacement system board:

- WLAN module (see [WLAN module on page 45](#))
- Memory modules (see [Memory module on page 48](#))
- Solid-state drive (if installed) (see [Solid-state drive on page 50](#))
- Heat sink assembly (see [Heat sink assembly on page 59](#))

To remove the system board:

1. Position the computer upright, and then disconnect the following cables from the system board:

- (1): Power connector cable
- (2): Display cable
- (3): Power button board
- (4): Speaker cable
- (5): TouchPad cable
- (6): Touchpad board cable
- (7): USB board cable
- (8): Optical drive connector cable
- (9): Keyboard cable

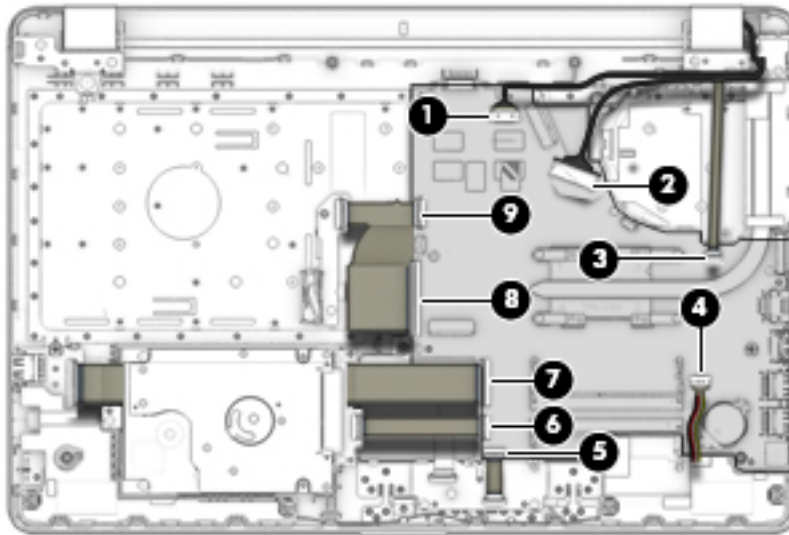

2. Remove the seven Phillips PM2.0×3.0 screws (1) that secure the system board to the computer.
3. Remove the Phillips broadhead PM2.0×2.0 screw (2) that secures the system board to the computer.

4. Lift the system board out of the computer **(3)**.

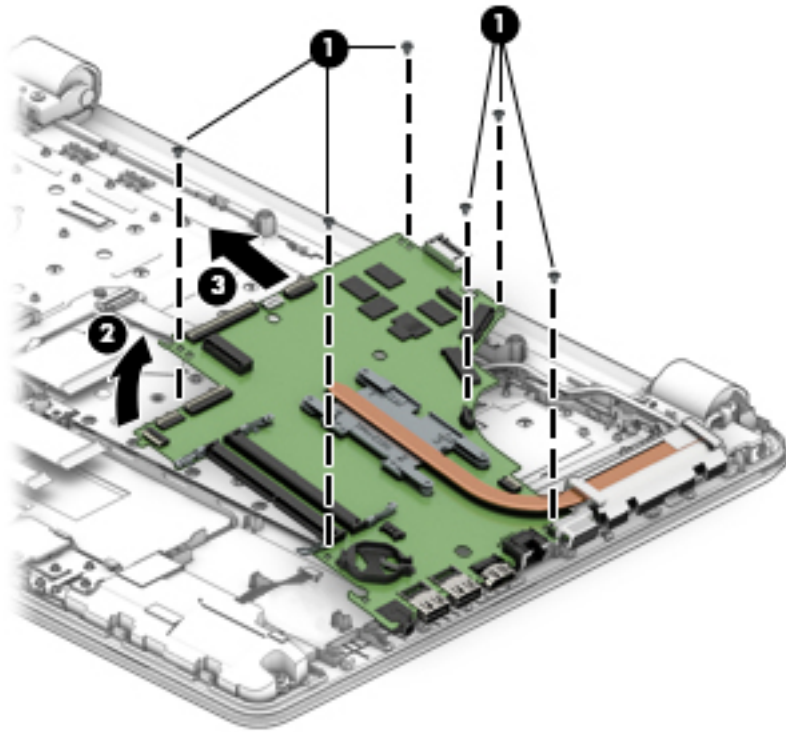

Reverse this procedure to install the system board.

Display assembly

Description	Spare part number
Raw display panel (43.9-cm [17.3-in]; includes screw covers)	
FHD, anti glare, non-touch	798926-011
HD, Touch On Panel (TOP)	851049-003
HD+, BrightView, non-touch	851051-005
HD+, anti glare, non-touch	910136-003
Display bezel	926504-001
Display cable	
Non-touch displays	926519-001
Touch displays	926520-001
Display enclosure for use in non-touch models:	
Pike silver	926482-001
Silk gold	926483-001
Smoke gray	926484-001
Marine blue	926485-001
Amethyst purple	926486-001
Pale mint	926487-001
Champagne rose	926488-001
Jet black	926489-001
Snow white	926480-001
Empress red	926490-001
Rose gold	926491-001
Silk gold	L00661-001
Display enclosure for use in touch models:	
Pike silver	933291-001
Silk gold	933292-001
Smoke gray	933293-001
Marine blue	933294-001
Amethyst purple	933295-001
Pale mint	933296-001
Champagne rose	933297-001
Jet black	933298-001
Snow white	933299-001
Empress red	933300-001

Description	Spare part number
Rose gold	933301-001
Silk gold	L00662-001
Hinges (left and right)	926527-001
Hinge covers	
Left, jet black	926533-001
Right, jet black	926534-001
Left, snow white	926535-001
Right, snow white	926536-001
Left, pike silver	926537-001
Right, pike silver	926538-001
Left, rose gold	926542-001
Right, rose gold	926543-001
Left, champagne rose	926544-001
Right, champagne rose	926545-001
Left, silk gold	928883-001
Right, silk gold	928884-001
Webcam/microphone module	
HD	919471-003
VGA	919472-003
Touch control board (includes tape and EMI foil)	926532-001

Before removing the display assembly, follow these steps:

1. Shut down the computer. If you are unsure whether the computer is off or in Hibernation, turn the computer on, and then shut it down through the operating system.
2. Disconnect all external devices connected to the computer.
3. Disconnect the power from the computer by first unplugging the power cord from the AC outlet and then unplugging the AC adapter from the computer.
4. Remove the battery (see [Battery on page 32](#)).
5. Remove the optical drive (see [Optical drive on page 34](#)).
6. Remove the bottom cover (see [Bottom cover on page 41](#)).
7. Remove the fan (see [Fan on page 58](#)).
8. Remove the heat sink (see [Heat sink assembly on page 59](#)).

To remove the display assembly:

1. Remove the black Mylar tape from near each hinge **(1)**.
2. Disconnect the wireless antenna cables from the WLAN module **(2)**.

3. Disconnect the power connector cable **(3)** and display cable **(4)** from the system board .

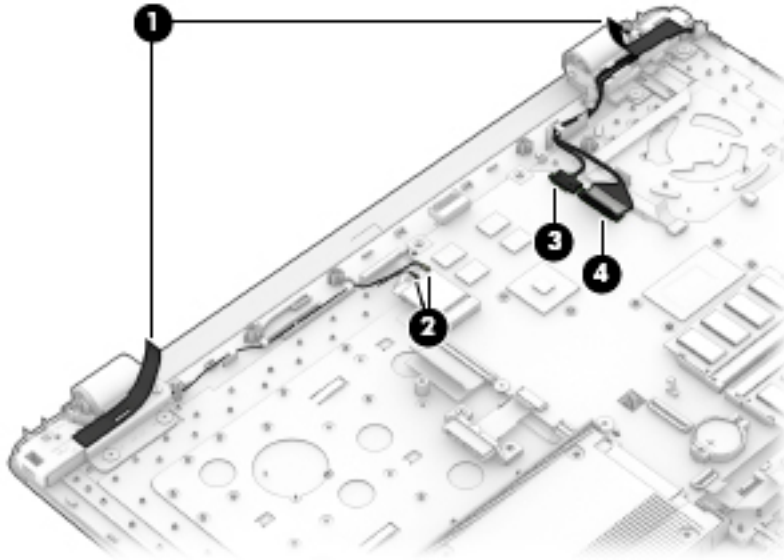

4. Remove the two Phillips PM2.5×5.0 screws **(1)** that secure each hinge to the computer.
5. Remove the two Phillips broadhead PM2.0×2.0 screws **(2)** that secure each hinge to the computer.

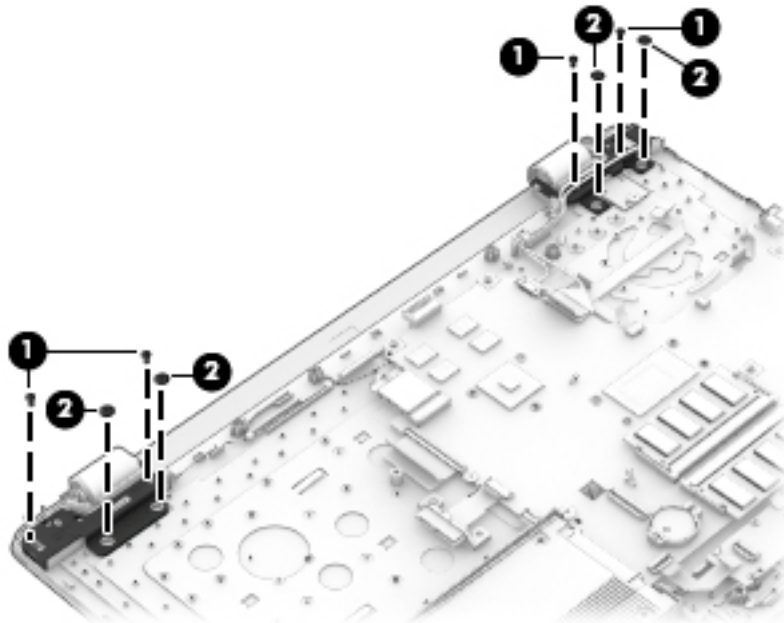

6. Remove the display cable routing guide from the display enclosure.

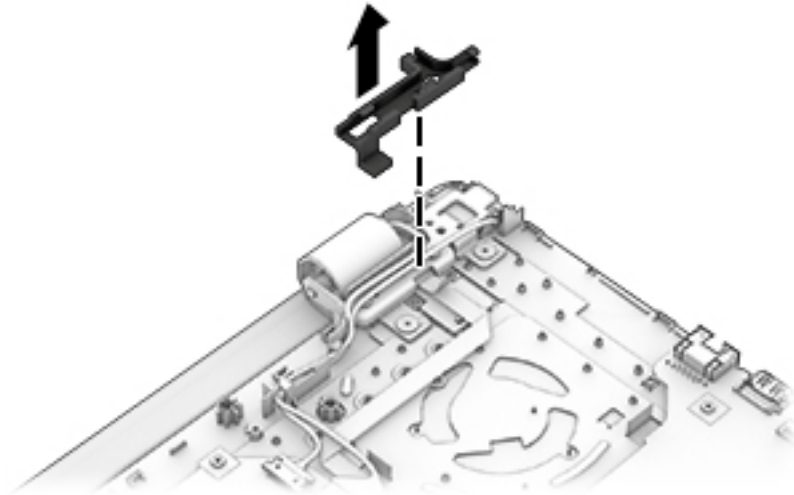

7. Open the display to rotate the hinges upward to an angle (1).
8. Separate the display assembly from the computer (2).

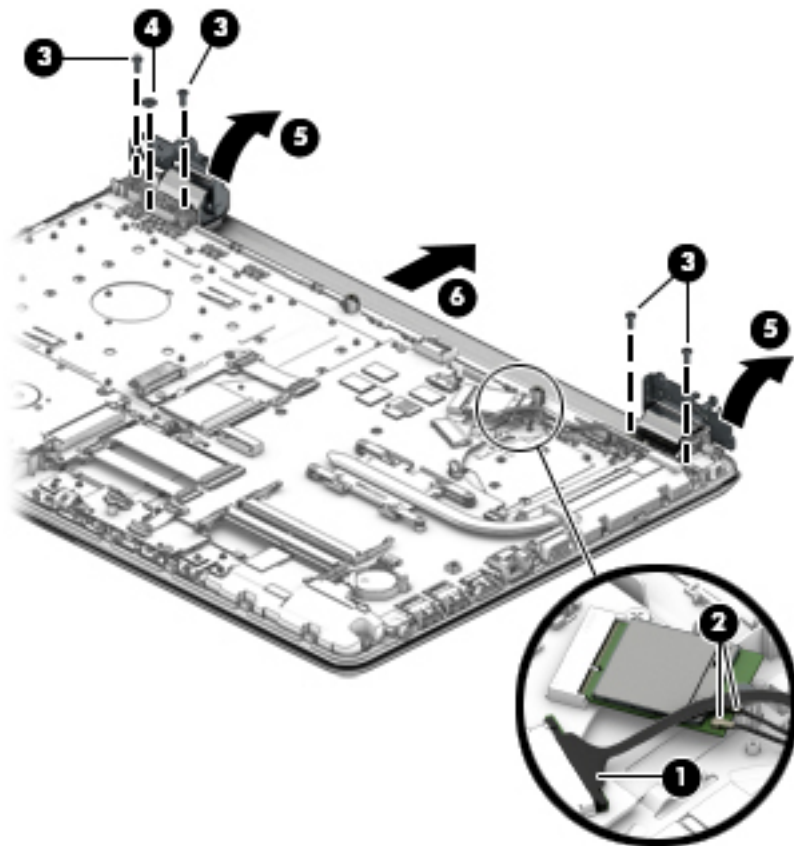

If it is necessary to replace any of the display assembly subcomponents:

1. Flex the inside of the top edge (1), left (2) and right sides (3), and the inside of the bottom edge (4) of the display bezel until the bezel disengages from the display enclosure.

2. Remove the display bezel (5).



NOTE: In this procedure the display will not be connected to the computer as shown in the following image.



3. To remove the webcam/microphone module:

- a. Position the display assembly with the top edge toward you.
- b. Lift to disengage the adhesive that secures the webcam/microphone module to the display (1).

- c. Disconnect the cable **(2)** from the module.

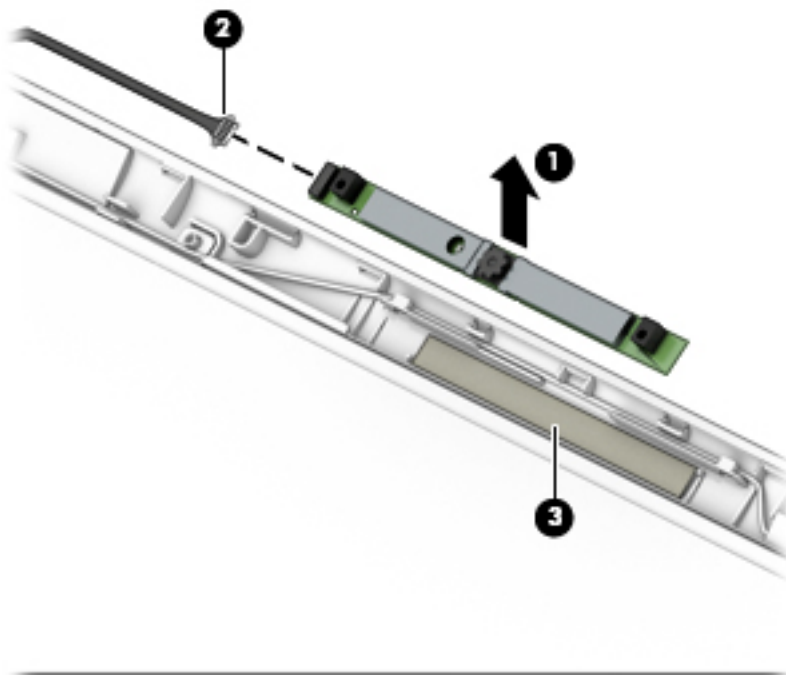

4. To remove the display panel:

- a. Remove the four Phillips PM2.0×3.0 screws that secure the display panel to the enclosure.



NOTE: In this procedure the display will not be connected to the computer as shown in the following image.



- b. Rotate the display panel onto the keyboard **(1)** to gain access to the display cable connection on the back of the panel.

- c. On the back of the display panel, release the adhesive strip that secures the display panel cable to the display panel **(2)**, and then disconnect the cable **(3)**.
- d. Remove the display panel from the computer.

 **NOTE:** In this procedure the display will not be connected to the computer as shown in the following image.

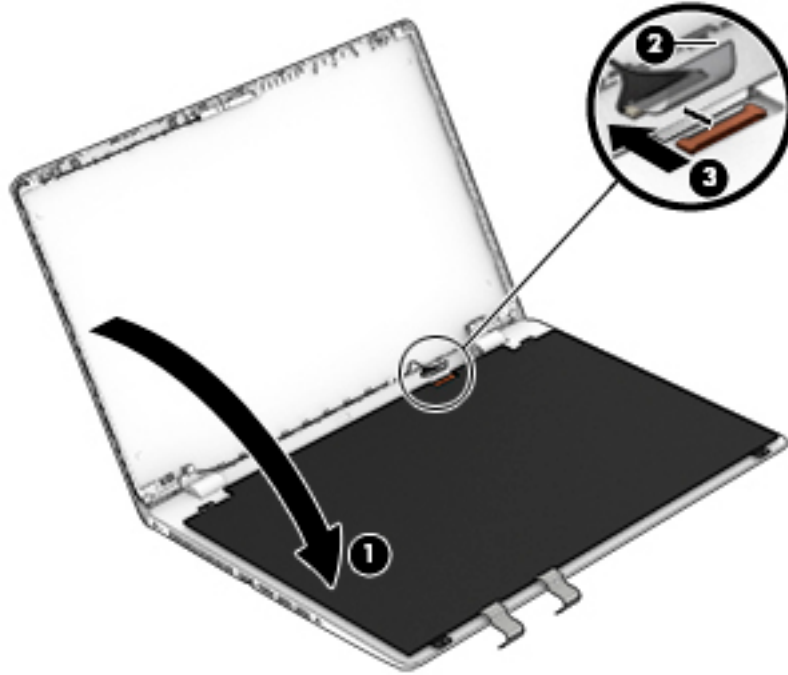

- 5. To remove the touch control board from the display:
 - a. Remove the two Phillips PM2.0×2.0 screws **(1)** that secure the touch control board to the top of the display assembly.
 - b. Lift the board away from the display **(2)** enough to access the cables underneath.

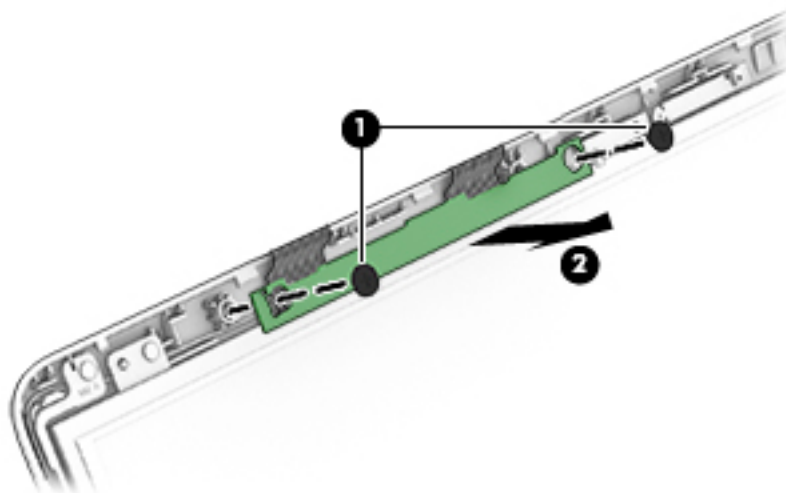

- c. Rotate the board upside down to access the connectors underneath **(1)**.

- d. Disconnect the two cables from the board **(2)(3)**.
- e. Remove the touch control board from the display assembly.

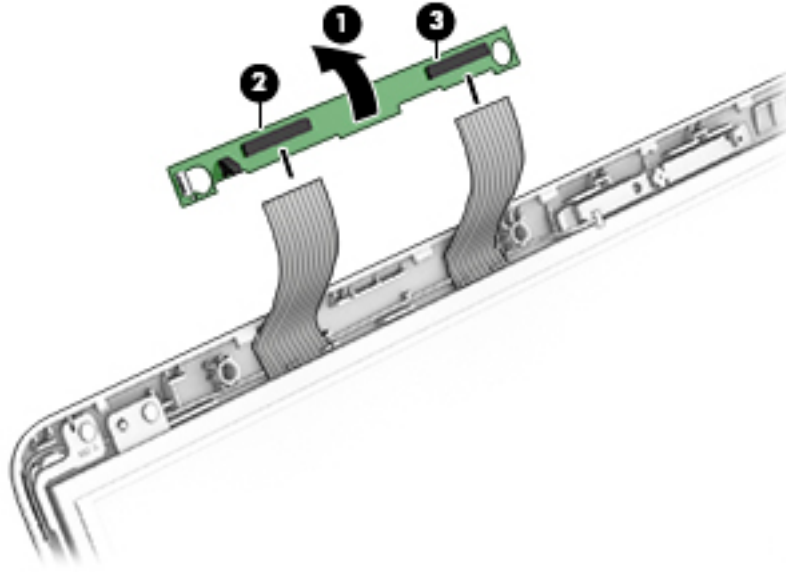

- 6. To remove the display hinge covers:
 - a. Remove the Phillips PM2.0×5.0 screw **(1)** that secures each hinge cover to the display enclosure.
 - b. Slide the right hinge cover toward the right and the left hinge cover toward the left **(2)** to remove them from the display.

- c. For installation, note the routing of the display cable through the left hinge cover **(3)** and display cable through the right hinge cover **(4)**.

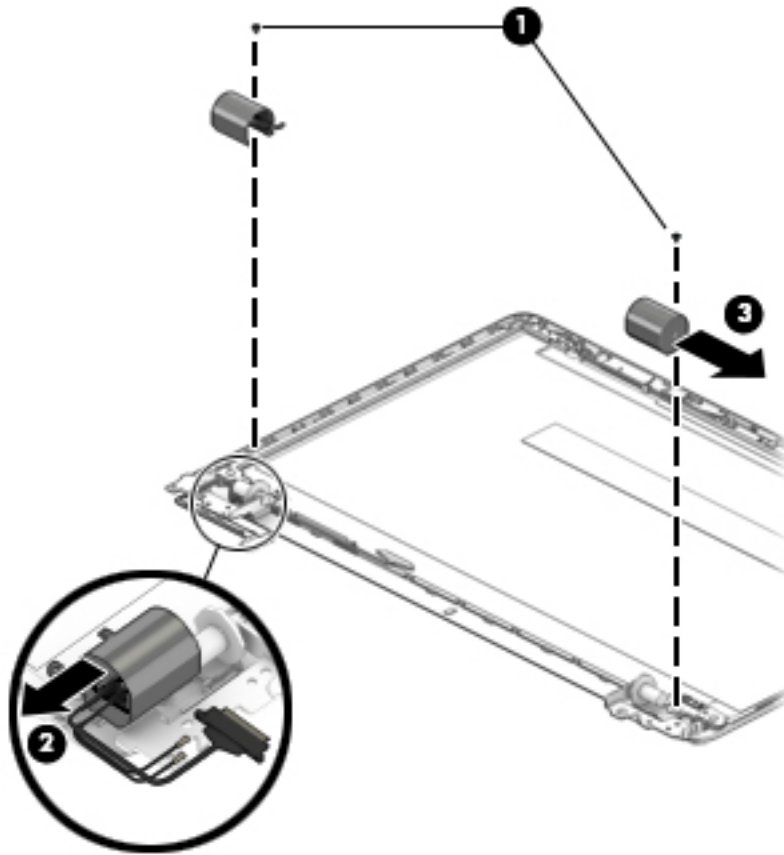

- 7. To remove the display hinges:
 - a. Remove the Phillips PM2.0×3.0 screw **(1)** from the top of each hinge and three Phillips PM2.5×4.0 screws **(2)** from the bottom of each hinge.

- b. Remove the display hinges from the panel (3).

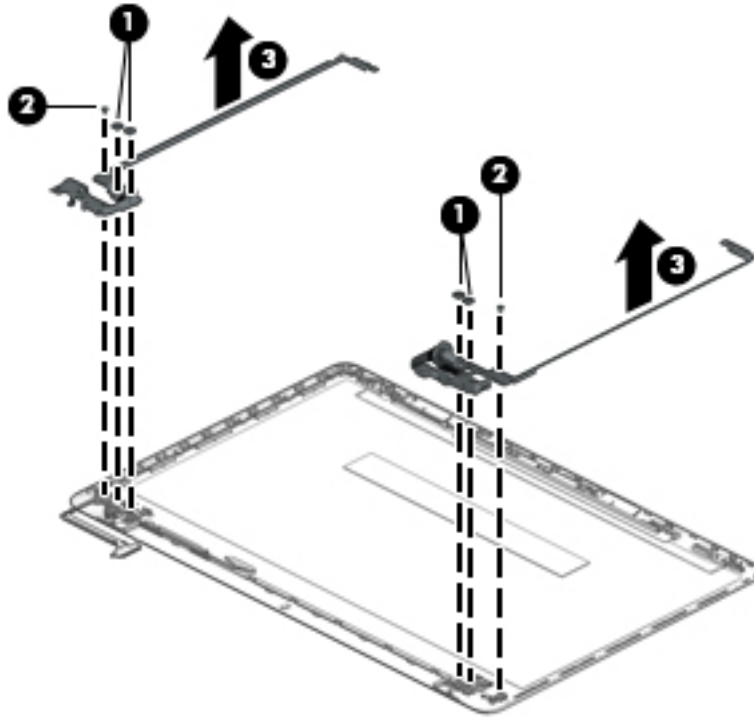

8. To remove the wireless antennas and cables, peel the antennas of the display enclosure (1), release the wireless antenna cables from the clips (2) built into the side of the display enclosure, and then remove the antennas and cables.

 **NOTE:** Number of antennas and transceivers may vary.

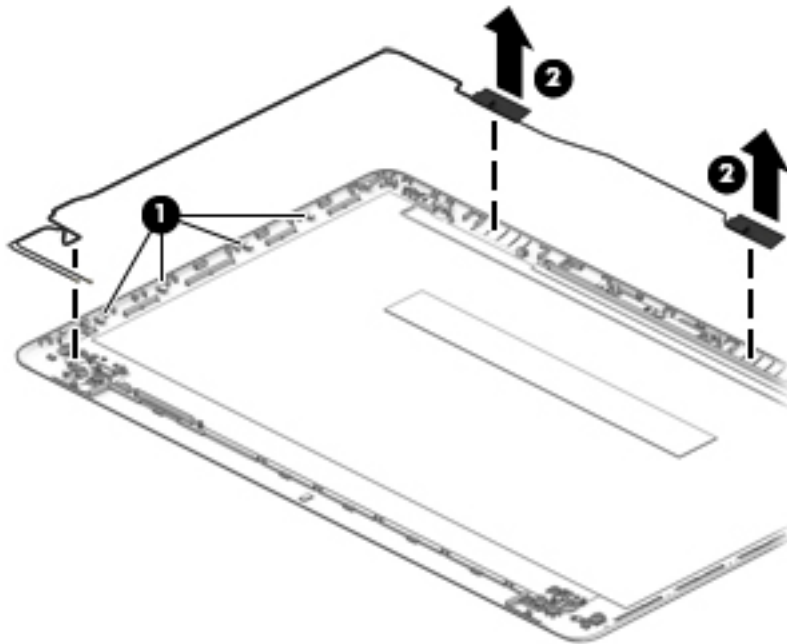

9. To remove the display/webcam cable, lift the cable **(1)** from the clips built into the display panel **(2)**, and then remove the cable from the display.

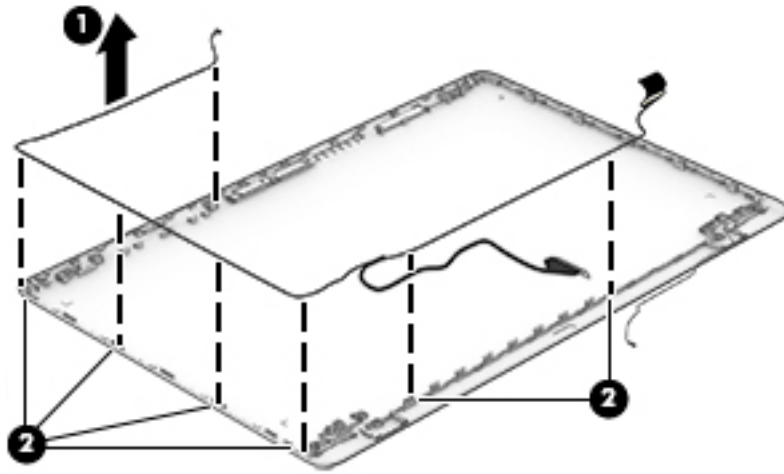

10. If replacing the display enclosure, be sure that the subcomponents (including the webcam/microphone module, the antenna receivers, and all associated cables and hardware) are transferred to the new enclosure.

Reverse this procedure to reassemble and install the display assembly.

When reassembling and reinstalling the display assembly, use the following images to determine how to correctly route the cables in the display. In the following image, note the location to route the antenna cables **(1)** and display/webcam cable routing bracket **(2)**.

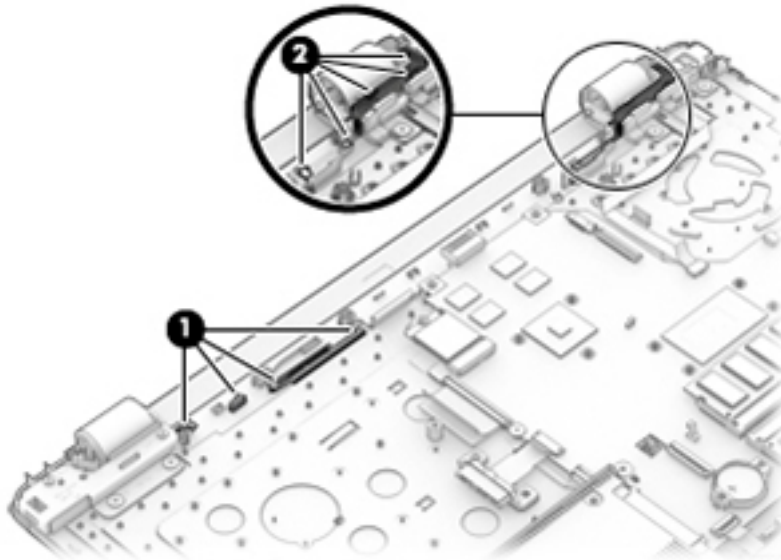

In the following image, note the correctly routed antenna cables **(1)** and display/webcam cable **(2)**.

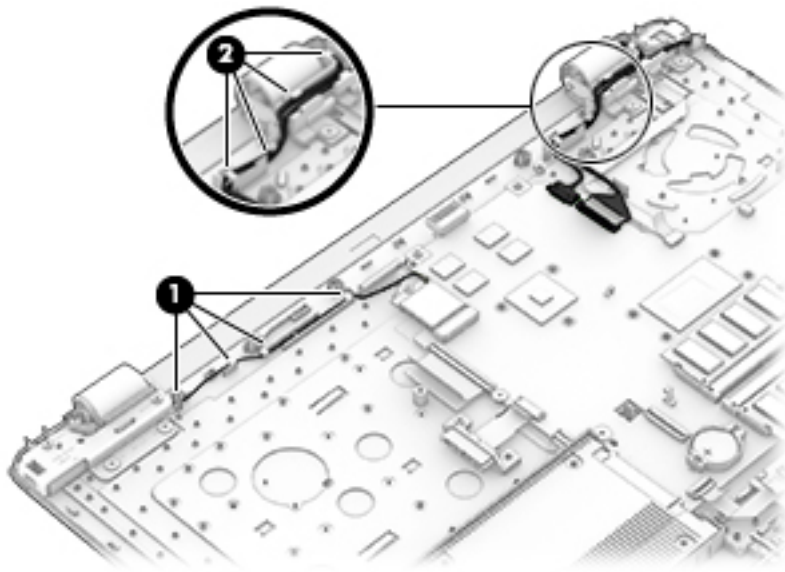

Power button board

Description	Spare part number
Power button board	926529-001
Power button board cable	926517-001

Before removing the power button board, follow these steps:

1. Shut down the computer. If you are unsure whether the computer is off or in Hibernation, turn the computer on, and then shut it down through the operating system.
2. Disconnect all external devices connected to the computer.
3. Disconnect the power from the computer by first unplugging the power cord from the AC outlet and then unplugging the AC adapter from the computer.
4. Remove the battery (see [Battery on page 32](#)).
5. Remove the optical drive (see [Optical drive on page 34](#)).
6. Remove the bottom cover (see [Bottom cover on page 41](#)).
7. Remove the fan/heat sink (see [Heat sink assembly on page 59](#)).
8. Remove the display (see [Display assembly on page 67](#)).

To remove the power button board:

1. Disconnect the cable from the power button board **(1)**.
2. Remove the Phillips PM2.0×2.0 screw **(2)** that secures the board to the computer.
3. Remove the power button board from the computer **(3)**.

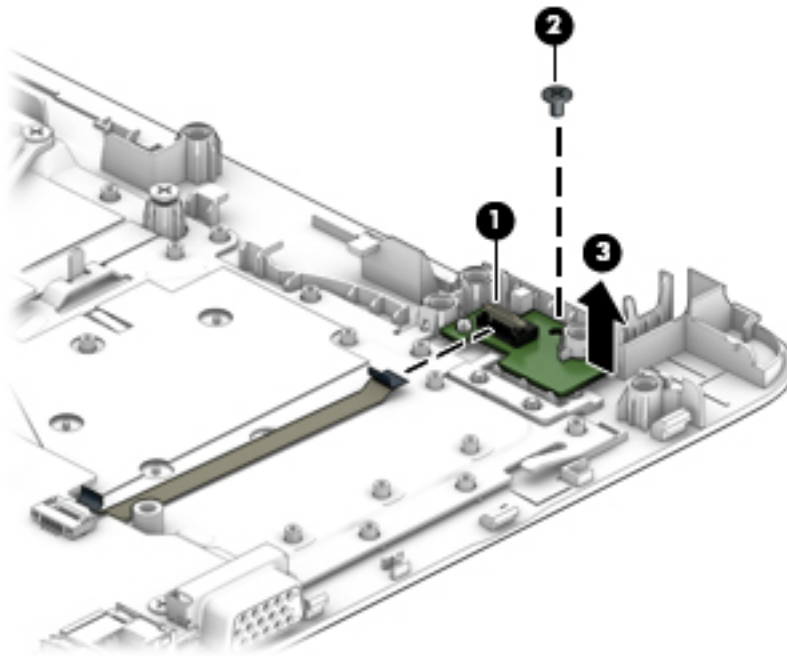

Reverse this procedure to install the power button board.

Power connector

Description	Spare part number
Power connector cable	810326-010

Before removing the power connector cable, follow these steps:

1. Shut down the computer. If you are unsure whether the computer is off or in Hibernation, turn the computer on, and then shut it down through the operating system.
2. Disconnect all external devices connected to the computer.
3. Disconnect the power from the computer by first unplugging the power cord from the AC outlet and then unplugging the AC adapter from the computer.
4. Remove the battery (see [Battery on page 32](#)).
5. Remove the optical drive (see [Optical drive on page 34](#)).
6. Remove the bottom cover (see [Bottom cover on page 41](#)).
7. Remove the fan/heat sink (see [Heat sink assembly on page 59](#)).
8. Remove the display (see [Display assembly on page 67](#)).

To remove the power connector cable:

- ▲ Pull the tabs away from the connector and remove the power connector from the computer.

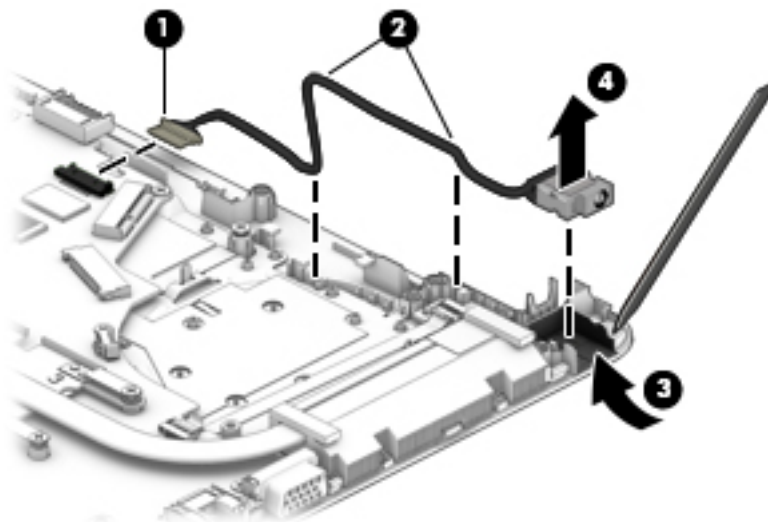

Reverse this procedure to install the power connector cable.

Top cover/keyboard

In this section, the first table provides the main spare part number for the keyboard. The second table provides the country codes.



NOTE: All top cover/keyboard spare part kits include TouchPad mylar. Kits do not include TouchPad board or TouchPad click board.

Description	Spare part number
Top cover/keyboard - black	926559-xx1
Top cover/keyboard - ash silver; not backlit	926560-xx1
Top cover/keyboard - ash silver; backlit	926562-xx1
NOTE: Only available in -001 (United States) and -DB1 (French Canada)	
Top cover/keyboard - snow white	926561-xx1
Top cover/keyboard - champagne rose, not backlit	934116-001
Only available in -001 (United States)	
Top cover/keyboard - champagne rose, backlit	934117-001
Only available in -001 (United States)	
Top cover/keyboard - rose gold, not backlit	934118-001
Only available in -001 (United States)	
Top cover/keyboard - rose gold, backlit	934119-001
Only available in -001 (United States)	
Top cover/keyboard - silk gold, not backlit	L00663-001
Only available in -001 (United States)	
Top cover/keyboard - silk gold, backlit	L00664-001
Only available in -001 (United States)	

For use in country or region	Spare part number	For use in country or region	Spare part number	For use in country or region	Spare part number
Belgium	-A41	Hungary	-211	Slovenia	-BA1
Bulgaria	-261	Israel	-BB1	South Korea	-AD1
Canada	-DB1	Italy	-061	Spain	-071
Czech Republic and Slovakia	-FL1	The Netherlands	-B31	Switzerland	-BG1
Denmark, Finland, and Norway	-DH1	Portugal	-131	Turkey	-141
France	-051	Romania	-271	United Kingdom	-031
Germany	-041	Russia	-251	United States	-001
Greece	-151	Saudi Arabia	-171		

The top cover/keyboard spare part kit includes the keyboard, keyboard cable and the keyboard backlight cable.

The top cover/keyboard spare part remains after all other spare parts have been removed.

7 Using Setup Utility (BIOS)

Setup Utility, or Basic Input/Output System (BIOS), controls communication between all the input and output devices on the system (such as disk drives, display, keyboard, mouse, and printer). Setup Utility (BIOS) includes settings for the types of devices installed, the startup sequence of the computer, and the amount of system and extended memory.

 **NOTE:** To start Setup Utility on convertible computers, your computer must be in notebook mode and you must use the keyboard attached to your notebook.

Starting Setup Utility (BIOS)

 **CAUTION:** Use extreme care when making changes in Setup Utility (BIOS). Errors can prevent the computer from operating properly.

- ▲ Turn on or restart the computer, quickly press **esc**, and then press **f10**.

Updating Setup Utility (BIOS)

Updated versions of Setup Utility (BIOS) may be available on the HP website.

Most BIOS updates on the HP website are packaged in compressed files called *SoftPaqs*.

Some download packages contain a file named *Readme.txt*, which contains information regarding installing and troubleshooting the file.

Determining the BIOS version

To decide whether you need to update Setup Utility (BIOS), first determine the BIOS version on your computer.

To reveal the BIOS version information (also known as *ROM date* and *System BIOS*), use one of these options.

- HP Support Assistant
 1. Type `support` in the taskbar search box, and then select the **HP Support Assistant** app.
– or –
Click the question mark icon in the taskbar.
 2. Select **My PC**, and then select **Specifications**.
- Setup Utility (BIOS)
 1. Start Setup Utility (BIOS) (see [Starting Setup Utility \(BIOS\) on page 83](#)).
 2. Select **Main**, select **System Information**, and then make note of the BIOS version.
 3. Select **Exit**, select **No**, and then follow the on-screen instructions.

To check for later BIOS versions, see [Downloading a BIOS update on page 84](#).

Downloading a BIOS update

 **CAUTION:** To reduce the risk of damage to the computer or an unsuccessful installation, download and install a BIOS update only when the computer is connected to reliable external power using the AC adapter. Do not download or install a BIOS update while the computer is running on battery power, docked in an optional docking device, or connected to an optional power source. During the download and installation, follow these instructions:

- Do not disconnect power from the computer by unplugging the power cord from the AC outlet.
- Do not shut down the computer or initiate Sleep.
- Do not insert, remove, connect, or disconnect any device, cable, or cord.

 **NOTE:** If your computer is connected to a network, consult the network administrator before installing any software updates, especially system BIOS updates.

1. Type `support` in the taskbar search box, and then select the **HP Support Assistant** app.
– or –
Click the question mark icon in the taskbar.
2. Click **Updates**, and then click **Check for updates and messages**.
3. Follow the on-screen instructions.
4. At the download area, follow these steps:
 - a. Identify the most recent BIOS update and compare it to the BIOS version currently installed on your computer. If the update is more recent than your BIOS version, make a note of the date, name, or other identifier. You may need this information to locate the update later, after it has been downloaded to your hard drive.
 - b. Follow the on-screen instructions to download your selection to the hard drive.

Make a note of the path to the location on your hard drive where the BIOS update is downloaded. You will need to access this path when you are ready to install the update.

BIOS installation procedures vary. Follow any instructions that appear on the screen after the download is complete. If no instructions appear, follow these steps:

1. Type `file` in the taskbar search box, and then select **File Explorer**.
2. Click your hard drive designation. The hard drive designation is typically Local Disk (C:).
3. Using the hard drive path you recorded earlier, open the folder that contains the update.
4. Double-click the file that has an `.exe` extension (for example, `filename.exe`).

The BIOS installation begins.
5. Complete the installation by following the on-screen instructions.

 **NOTE:** After a message on the screen reports a successful installation, you can delete the downloaded file from your hard drive.

8 Backing up, restoring, and recovering

This chapter provides information about the following processes. The information in the chapter is standard procedure for most products.

- Creating recovery media and backups
- Restoring and recovering your system

For additional information, refer to the HP Support Assistant app.

- ▲ Type `support` in the taskbar search box, and then select the **HP Support Assistant** app.

– or –

Select the question mark icon in the taskbar.

 **IMPORTANT:** If you will be performing recovery procedures on a tablet, the tablet battery must be at least 70% charged before you start the recovery process.

IMPORTANT: For a tablet with a detachable keyboard, connect the tablet to the keyboard base before beginning any recovery process.

Creating recovery media and backups

The following methods of creating recovery media and backups are available on select products only. Choose the available method according to your computer model.

- Use HP Recovery Manager to create HP Recovery media after you successfully set up the computer. This step creates a backup of the HP Recovery partition on the computer. The backup can be used to reinstall the original operating system in cases where the hard drive is corrupted or has been replaced. For information on creating recovery media, see [Creating HP Recovery media \(select products only\) on page 85](#). For information on the recovery options that are available using the recovery media, see [Using Windows tools on page 86](#).

- Use Windows tools to create system restore points and create backups of personal information.

For more information, see [Recovering using HP Recovery Manager on page 87](#).

 **NOTE:** If storage is 32 GB or less, Microsoft System Restore is disabled by default.

- On select products, use the HP Cloud Recovery Download Tool to create a bootable USB drive for your HP recovery media. Go to <https://support.hp.com/us-en/document/c05115630?openCLC=true>, select your country or region, and follow the on-screen instructions.

Creating HP Recovery media (select products only)

If possible, check for the presence of the Recovery partition and the Windows partition. Right-click the **Start** menu, select **File Explorer**, and then select **This PC**.

- If your computer does not list the Windows partition and the Recovery partition, you can obtain recovery media for your system from support. You can find contact information on the HP website. Go to <http://www.hp.com/support>, select your country or region, and follow the on-screen instructions.

You can use Windows tools to create system restore points and create backups of personal information, see [Using Windows tools on page 86](#).

- If your computer does list the Recovery partition and the Windows partition, you can use HP Recovery Manager to create recovery media after you successfully set up the computer. HP Recovery media can be used to perform system recovery if the hard drive becomes corrupted. System recovery reinstalls the original operating system and software programs that were installed at the factory and then configures the settings for the programs. HP Recovery media can also be used to customize the system or restore the factory image if you replace the hard drive.
 - Only one set of recovery media can be created. Handle these recovery tools carefully, and keep them in a safe place.
 - HP Recovery Manager examines the computer and determines the required storage capacity for the media that will be required.
 - To create recovery discs, your computer must have an optical drive with DVD writer capability, and you must use only high-quality blank DVD-R, DVD+R, DVD-R DL, or DVD+R DL discs. Do not use rewritable discs such as CD±RW, DVD±RW, double-layer DVD±RW, or BD-RE (rewritable Blu-ray) discs; they are not compatible with HP Recovery Manager software. Or, instead, you can use a high-quality blank USB flash drive.
 - If your computer does not include an integrated optical drive with DVD writer capability, but you would like to create DVD recovery media, you can use an external optical drive (purchased separately) to create recovery discs. If you use an external optical drive, it must be connected directly to a USB port on the computer; the drive cannot be connected to a USB port on an external device, such as a USB hub. If you cannot create DVD media yourself, you can obtain recovery discs for your computer from HP. You can find contact information on the HP website. Go to <http://www.hp.com/support>, select your country or region, and follow the on-screen instructions.
 - Be sure that the computer is connected to AC power before you begin creating the recovery media.
 - The creation process can take an hour or more. Do not interrupt the creation process.
 - If necessary, you can exit the program before you have finished creating all of the recovery DVDs. HP Recovery Manager will finish burning the current DVD. The next time you start HP Recovery Manager, you will be prompted to continue.

To create HP Recovery media:



IMPORTANT: For a tablet with a detachable keyboard, connect the tablet to the keyboard base before beginning these steps.

1. Type `recovery` in the taskbar search box, and then select **HP Recovery Manager**.
2. Select **Create recovery media**, and then follow the on-screen instructions.

If you ever need to recover the system, see [Recovering using HP Recovery Manager on page 87](#).

Using Windows tools

You can create recovery media, system restore points, and backups of personal information using Windows tools.



NOTE: If storage is 32 GB or less, Microsoft System Restore is disabled by default.

For more information and steps, see the Get help app.

- ▲ Select the **Start** button, and then select the **Get Help** app.

 **NOTE:** You must be connected to the Internet to access the Get help app.

Restore and recovery

There are several options for recovering your system. Choose the method that best matches your situation and level of expertise:

 **IMPORTANT:** Not all methods are available on all products.

- Windows offers several options for restoring from backup, refreshing the computer, and resetting the computer to its original state. For more information see the Get help app.

▲ Select the **Start** button, and then select the **Get Help** app.

 **NOTE:** You must be connected to the Internet to access the Get help app.

- If you need to correct a problem with a preinstalled application or driver, use the Reinstall drivers and/or applications option (select products only) of HP Recovery Manager to reinstall the individual application or driver.

▲ Type `recovery` in the taskbar search box, select **HP Recovery Manager**, select **Reinstall drivers and/or applications**, and then follow the on-screen instructions.

- If you want to recover the Windows partition to original factory content, you can choose the System Recovery option from the HP Recovery partition (select products only) or use the HP Recovery media. For more information, see [Recovering using HP Recovery Manager on page 87](#). If you have not already created recovery media, see [Creating HP Recovery media \(select products only\) on page 85](#).
- On select products, if you want to recover the computer's original factory partition and content, or if you have replaced the hard drive, you can use the Factory Reset option of HP Recovery media. For more information, see [Recovering using HP Recovery Manager on page 87](#).
- On select products, if you want to remove the Recovery partition to reclaim hard drive space, HP Recovery Manager offers the Remove Recovery Partition option.

For more information, see [Removing the HP Recovery partition \(select products only\) on page 89](#).

Recovering using HP Recovery Manager

HP Recovery Manager software allows you to recover the computer to its original factory state by using the HP Recovery media that you either created or that you obtained from HP, or by using the HP Recovery partition (select products only). If you have not already created recovery media, see [Creating HP Recovery media \(select products only\) on page 85](#).

What you need to know before you get started

- HP Recovery Manager recovers only software that was installed at the factory. For software not provided with this computer, you must either download the software from the manufacturer's website or reinstall the software from the media provided by the manufacturer.

 **IMPORTANT:** Recovery through HP Recovery Manager should be used as a final attempt to correct computer issues.

- HP Recovery media must be used if the computer hard drive fails. If you have not already created recovery media, see [Creating HP Recovery media \(select products only\) on page 85](#).

- To use the Factory Reset option (select products only), you must use HP Recovery media. If you have not already created recovery media, see [Creating HP Recovery media \(select products only\) on page 85](#).
- If your computer does not allow the creation of HP Recovery media or if the HP Recovery media does not work, you can obtain recovery media for your system from support. You can find contact information from the HP website. Go to <http://www.hp.com/support>, select your country or region, and follow the on-screen instructions.

 **IMPORTANT:** HP Recovery Manager does not automatically provide backups of your personal data. Before beginning recovery, back up any personal data you want to retain.

Using HP Recovery media, you can choose from one of the following recovery options:

 **NOTE:** Only the options available for your computer display when you start the recovery process.

- System Recovery—Reinstalls the original operating system, and then configures the settings for the programs that were installed at the factory.
- Factory Reset—Restores the computer to its original factory state by deleting all information from the hard drive and re-creating the partitions. Then it reinstalls the operating system and the software that was installed at the factory.

The HP Recovery partition (select products only) allows System Recovery only.

Using the HP Recovery partition (select products only)

The HP Recovery partition allows you to perform a system recovery without the need for recovery discs or a recovery USB flash drive. This type of recovery can be used only if the hard drive is still working.

To start HP Recovery Manager from the HP Recovery partition:

 **IMPORTANT:** For a tablet with a detachable keyboard, connect the tablet to the keyboard base before beginning these steps (select products only).

1. Type `recovery` in the taskbar search box, select **HP Recovery Manager**, and then select **Windows Recovery Environment**.

– or –

For computers or tablets with keyboards attached, press **f11** while the computer boots, or press and hold **f11** as you press the power button.

For tablets without keyboards:

- Turn on or restart the tablet, and then quickly hold down the volume up button; then select **f11**.

– or –

- Turn on or restart the tablet, and then quickly hold down the volume down button; then select **f11**.

2. Select **Troubleshoot** from the boot options menu.
3. Select **Recovery Manager**, and then follow the on-screen instructions.

Using HP Recovery media to recover

You can use HP Recovery media to recover the original system. This method can be used if your system does not have an HP Recovery partition or if the hard drive is not working properly.

1. If possible, back up all personal files.
2. Insert the HP Recovery media, and then restart the computer.



NOTE: If the computer does not automatically restart in HP Recovery Manager, change the computer boot order. See [Changing the computer boot order on page 89](#).

3. Follow the on-screen instructions.

Changing the computer boot order

If your computer does not restart in HP Recovery Manager, you can change the computer boot order, which is the order of devices listed in BIOS where the computer looks for startup information. You can change the selection to an optical drive or a USB flash drive.

To change the boot order:



IMPORTANT: For a tablet with a detachable keyboard, connect the tablet to the keyboard base before beginning these steps.

1. Insert the HP Recovery media.
2. Access the system **Startup** menu.

For computers or tablets with keyboards attached:

- ▲ Turn on or restart the computer or tablet, quickly press **esc**, and then press **f9** for boot options.

For tablets without keyboards:

- ▲ Turn on or restart the tablet, and then quickly hold down the volume up button; then select **f9**.

– or –

Turn on or restart the tablet, and then quickly hold down the volume down button; then select **f9**.

3. Select the optical drive or USB flash drive from which you want to boot.
4. Follow the on-screen instructions.

Removing the HP Recovery partition (select products only)

HP Recovery Manager software allows you to remove the HP Recovery partition to free up hard drive space.



IMPORTANT: After you remove the HP Recovery partition, you will not be able to perform System Recovery or create HP Recovery media from the HP Recovery partition. So before you remove the Recovery partition, create HP Recovery media; see [Creating HP Recovery media \(select products only\) on page 85](#).



NOTE: The Remove Recovery Partition option is only available on products that support this function.

Follow these steps to remove the HP Recovery partition:

1. Type `recovery` in the taskbar search box, and then select **HP Recovery Manager**.
2. Select **Remove Recovery Partition**, and then follow the on-screen instructions.

9 Using HP PC Hardware Diagnostics (UEFI)

HP PC Hardware Diagnostics is a Unified Extensible Firmware Interface (UEFI) that allows you to run diagnostic tests to determine whether the computer hardware is functioning properly. The tool runs outside the operating system so that it can isolate hardware failures from issues that are caused by the operating system or other software components.

When HP PC Hardware Diagnostics (UEFI) detects a failure that requires hardware replacement, a 24-digit Failure ID code is generated. This ID code can then be provided to support to help determine how to correct the problem.

 **NOTE:** To start diagnostics on a convertible computer, your computer must be in notebook mode and you must use the keyboard attached.

To start HP PC Hardware Diagnostics (UEFI), follow these steps:

1. Turn on or restart the computer, and quickly press **esc**.
2. Press **f2**.

The BIOS searches three places for the diagnostic tools, in the following order:

- a. Connected USB drive

 **NOTE:** To download the HP PC Hardware Diagnostics (UEFI) tool to a USB drive, see [Downloading HP PC Hardware Diagnostics \(UEFI\) to a USB device on page 92](#).

- b. Hard drive
- c. BIOS

3. When the diagnostic tool opens, select the type of diagnostic test you want to run, and then follow the on-screen instructions.

 **NOTE:** If you need to stop a diagnostic test, press **esc**.

Downloading HP PC Hardware Diagnostics (UEFI) to a USB device



NOTE: The HP PC Hardware Diagnostics (UEFI) download instructions are provided in English only, and you must use a Windows computer to download and create the HP UEFI support environment because only .exe files are offered.

There are two options to download HP PC Hardware Diagnostics to a USB device.

Download the latest UEFI version

1. Go to <http://www.hp.com/go/techcenter/pcdiags>. The HP PC Diagnostics home page is displayed.
2. In the HP PC Hardware Diagnostics section, select the **Download** link, and then select **Run**.

Download any version of UEFI for a specific product

1. Go to <http://www.hp.com/support>.
2. Select **Get software and drivers**.
3. Enter the product name or number.
4. Select your computer, and then select your operating system.
5. In the **Diagnostic** section, follow the on-screen instructions to select and download the UEFI version you want.

Additional BIOS crisis recovery tool

HP provides a BIOS crisis recovery tool through the HP PC Hardware Diagnostics 3-in-1 USB key. This tool can be used by HP authorized service providers to recover systems that have failed due to a corrupted BIOS. For more information about using the 3-in-1 USB key for BIOS crisis recovery, go to <http://www.hp.com/go/techcenter/pcdiags>. Additional information is included in the web-based training offered by HP University. See the modules that cover HP PC Hardware Diagnostics (UEFI).

10 Specifications

Computer specifications

	Metric	U.S.
Dimensions (touch models)		
Depth	278 mm	10.95 in
Width	415 mm	16.34 in
Height (rear)	24.6 mm	0.97 in
Weight		
Non-touch, fanless	2442 g	5.38 lb
Non-touch, fan	2596 g	5.72 lb
Touch, fanless	2571 g	5.67 lb
Touch, fan	2677 g	5.90 lb
Input power		
Operating voltage and current	19.5 V dc @ 2.31 A – 45 W	
	18.5 V dc @ 3.5 A or 19.5 V dc @ 3.33 A – 65 W	
Temperature		
Operating	5°C to 35°C	41°F to 95°F
Nonoperating	-20°C to 60°C	-4°F to 140°F
Relative humidity (noncondensing)		
Operating	10% to 90%	
Nonoperating	5% to 95%	
Maximum altitude (unpressurized)		
Operating	-15 m to 3,048 m	-50 ft to 10,000 ft
Nonoperating	-15 m to 12,192 m	-50 ft to 40,000 ft
NOTE: Applicable product safety standards specify thermal limits for plastic surfaces. The device operates well within this range of temperatures.		

43.9-cm (17.3-in) display specifications

	Metric	U.S.
Active diagonal size	43.9-cm	17.3-in
Thickness	4.0 mm	0.236 inch
Resolution	1920x1080 (FHD) 1600x900 (HD+)	
Surface treatment	AntiGlare or BrightView	
Brightness	220 nits (HD+) 300 nits (FHD)	
Viewing angle	SVA (HD+) UWVA (FHD)	
Backlight	WLED	
Graphics adapter	eDP	

Hard drive specifications

	2-TB*	1-TB*	500-GB*
Dimensions			
Height	7.2 mm or 9.5 mm	7.2 mm or 9.5 mm	7.2 mm
Length	100.4 mm	100.4 mm	100.6 mm
Width	69.9 mm	69.9 mm	70.1 mm
Weight	115.0 g	115.0 g	92.0 g
Interface type	SATA	SATA	SATA
Transfer rate			
Synchronous (maximum)	300 MB/sec	300 MB/sec	300 MB/sec
Security	ATA security	ATA security	ATA security
Seek times (typical read, including setting)			
Single track	1.4 ms	1.4 ms	3 ms
Average (read/write)	10 ms	10 ms	13 ms
Maximum	12 ms	12 ms	24 ms
Logical blocks	3,877,842,922	1,938,921,461	1,048,576,000
Disk rotational speed	5400 rpm	5400 rpm	5400 rpm
Operating temperature	0°C to 60°C (32°F to 140°F)		

*1 GB = 1 billion bytes when referring to hard drive storage capacity. Actual accessible capacity is less.

NOTE: Certain restrictions and exclusions apply. Contact technical support for details.

M.2 solid-state drive specifications

	128-GB*	256-GB*	512-GB*
Dimensions			
Height	1 mm	1 mm	1 mm
Length	50.8 mm	50.8 mm	50.8 mm
Width	28.9 mm	28.9 mm	28.9 mm
Weight	< 10 g	< 10 g	< 10 g
Interface type	SATA-3 (6 Gbps)	SATA-3 (6 Gbps)	SATA-3 (6 Gbps)
Transfer rate			
Sequential Read	Up to 520 MB/s	Up to 540 MB/s	Up to 530 MB/s
Random Read	Up to 60K IOPs	Up to 85K IOPs	Up to 97K IOPs
Sequential Write	Up to 160 MB/s	Up to 280 MB/s	Up to 515 MB/s
Random Write	Up to 34K IOPs	Up to 67K IOPs	Up to 88K IOPs
Ready time, Maximum (to not busy)	1.0 s	1.0 s	1.0 s
Access times			
Logical	0.1 ms	0.1	0.1
Total logical sectors	250,069,680	500,118,192	1,000,215,216
Operating temperature			
Operating	0° to 70°C (32°F to 158°F)	0° to 70°C (32°F to 158°F)	0° to 70°C (32°F to 158°F)
Non-operating	-40° to 95°C (-40°F to 203°F)	-55° to 90°C (-67°F to 194°F)	-40° to 85°C (-40°F to 185°F)
*1 GB = 1 billion bytes when referring to hard drive storage capacity. Actual accessible capacity is less.			
NOTE: Certain restrictions and exclusions apply. Contact technical support for details.			

DVD±RW SuperMulti DL Drive specifications

Component	Value	
Applicable disc	Read: CD-DA, CD+(E)G, CD-MIDI, CD-TEXT, CD-ROM, CD-ROM XA, MIXED MODE CD, CD-I, CD-I Bridge (Photo-CD, Video CD), Multisession CD (Photo-CD, CD-EXTRA, Portfolio, CD-R, CD-RW), CD-R, CD-RW, DVD-ROM (DVD-5, DVD-9, DVD-10, DVD-18), DVD-R, DVD-RW, DVD+R, DVD+RW, DVD-RAM	Write: CD-R and CD-RW DVD+R, DVD+RW, DVD-R, DVD-RW, DVD-RAM
Center hole diameter	1.5 cm (0.59 in)	
Disc diameter		
Standard disc	12 cm (4.72 in)	
Mini disc	8 cm (3.15 in)	
Disc thickness	1.2 mm (0.047 in)	
Track pitch	0.74 µm	
Access time	CD	DVD
Random	< 175 ms	< 230 ms
Full stroke	< 285 ms	< 335 ms
Audio output level	Line-out, 0.7 Vrms	
Cache buffer	2 MB	
Data transfer rate		
24X CD-ROM	3,600 KB/sec	
8X DVD-ROM	10,800 KB/sec	
24X CD-R	3,600 KB/sec	
16X CD-RW	2,400 KB/sec	
8X DVD+R	10,800 KB/sec	
4X DVD+RW	5,400 KB/sec	
8X DVD-R	10,800 KB/sec	
4X DVD-RW	5,400 KB/sec	
2.4X DVD+R(9)	2,700 KB/sec	
5X DVD-RAM	6,750 KB/sec	
Transfer mode	Multiword DMA Mode	
Startup time	< 15 seconds	
Stop time	< 6 seconds	

11 Power cord set requirements

The wide-range input feature of the computer permits it to operate from any line voltage from 100 to 120 V ac, or from 220 to 240 V ac.

The 3-conductor power cord set included with the computer meets the requirements for use in the country or region where the equipment is purchased.

Power cord sets for use in other countries or regions must meet the requirements of the country and region where the computer is used.

Requirements for all countries

The following requirements are applicable to all countries and regions:

- The length of the power cord set must be at least **1.0 m** (3.3 ft) and no more than **2.0 m** (6.5 ft).
- All power cord sets must be approved by an acceptable accredited agency responsible for evaluation in the country or region where the power cord set will be used.
- The power cord sets must have a minimum current capacity of 10 A and a nominal voltage rating of 125 or 250 V ac, as required by the power system of each country or region.
- The appliance coupler must meet the mechanical configuration of an EN 60 320/IEC 320 Standard Sheet C13 connector for mating with the appliance inlet on the back of the computer.

Requirements for specific countries and regions

Country/region	Accredited agency	Applicable note number
Argentina	IRAM	1
Australia	SAA	1
Austria	OVE	1
Belgium	CEBEC	1
Brazil	ABNT	1
Canada	CSA	2
Chile	IMQ	1
Denmark	DEMKO	1
Finland	FIMKO	1
France	UTE	1
Germany	VDE	1
India	BIS	1
Israel	SII	1
Italy	IMQ	1
Japan	JIS	3
The Netherlands	KEMA	1
New Zealand	SANZ	1
Norway	NEMKO	1
The People's Republic of China	CCC	4
Saudi Arabia	SASO	7
Singapore	PSB	1
South Africa	SABS	1
South Korea	KTL	5
Sweden	SEMKO	1
Switzerland	SEV	1
Taiwan	BSMI	6
Thailand	TISI	1
The United Kingdom	ASTA	1
The United States	UL	2

1. The flexible cord must be Type H05VV-F, 3-conductor, 0.75 mm² conductor size. Power cord set fittings (appliance coupler and wall plug) must bear the certification mark of the agency responsible for evaluation in the country or region where it will be used.
2. The flexible cord must be Type SVT/SJT or equivalent, No. 18 AWG, 3-conductor. The wall plug must be a two-pole grounding type with a NEMA 5-15P (15 A, 125 V ac) or NEMA 6-15P (15 A, 250 V ac) configuration. CSA or C-UL mark. UL file number must be on each element.

Country/region	Accredited agency	Applicable note number
		3. The appliance coupler, flexible cord, and wall plug must bear a “T” mark and registration number in accordance with the Japanese Dentori Law. The flexible cord must be Type VCTF, 3-conductor, 0.75 mm ² or 1.25 mm ² conductor size. The wall plug must be a two-pole grounding type with a Japanese Industrial Standard C8303 (7 A, 125 V ac) configuration.
		4. The flexible cord must be Type RVV, 3-conductor, 0.75 mm ² conductor size. Power cord set fittings (appliance coupler and wall plug) must bear the CCC certification mark.
		5. The flexible cord must be Type H05VV-F 3-conductor, 0.75 mm ² conductor size. KTL logo and individual approval number must be on each element. Corset approval number and logo must be printed on a flag label.
		6. The flexible cord must be Type HVCTF 3-conductor, 1.25 mm ² conductor size. Power cord set fittings (appliance coupler, cable, and wall plug) must bear the BSMI certification mark.
		7. For 127 V ac, the flexible cord must be Type SVT or SJT 3-conductor, 18 AWG, with plug NEMA 5-15P (15 A, 125 V ac), with UL and CSA or C-UL marks. For 240 V ac, the flexible cord must be Type H05VV-F 3-conductor, 0.75 mm ² or 1.00 mm ² conductor size, with plug BS 1363/A with BSI or ASTA marks.

12 Recycling

When a non-rechargeable or rechargeable battery has reached the end of its useful life, do not dispose of the battery in general household waste. Follow the local laws and regulations in your area for battery disposal.

HP encourages customers to recycle used electronic hardware, HP original print cartridges, and rechargeable batteries. For more information about recycling programs, see the HP Web site at <http://www.hp.com/recycle>.

Index

A

- AC adapter and battery 8
- action keys
 - identifying 13
- antennas
 - illustrated 23
 - removing 76
- audio, product description 3
- audio-out (headphone)/audio-in (microphone) jack, identifying 8

B

- backups 85
- battery
 - illustrated 20
 - removing 32
- battery cover, identifying 14
- battery lock, identifying 14
- battery release latch 14
- BIOS
 - determining version 83
 - downloading an update 84
 - starting the Setup Utility 83
 - updating 83
- Bluetooth label 16
- boot order
 - changing 89
- bottom 16
- bottom cover
 - illustrated 20
 - removing 41
- buttons
 - left TouchPad 10
 - power 12
 - right TouchPad 10

C

- cables, service considerations 27
- camera
 - identifying 9
- camera light, identifying 9
- caps lock light, identifying 11
- components
 - bottom 14
 - display 9

- keyboard area 10
 - left side 8
 - right side 7
- computer major components, illustrated 17
- computer specifications 93
- connector, power 8
- connectors, service considerations 27

D

- display assembly
 - illustrated 18
 - removing 37, 67
 - spare part numbers 18
- display assembly subcomponents
 - illustrated 22
 - removing 37, 67
- display bezel
 - illustrated 22
 - removing 38, 70
- display cable
 - illustrated 23
 - removing 77
- display cable frame guide
 - illustrated 19
- display enclosure
 - illustrated 23
 - removing 77
- display panel
 - illustrated 22, 67
 - product description 2
 - removing 39, 72
- display specifications 94
- drive light 7
- DVD±RW SuperMulti DL Drive specifications 96

E

- electrostatic discharge 28
- equipment guidelines 30
- esc key, identifying 13
- Ethernet, product description 4
- external media cards 4

F

- fan
 - illustrated 19
 - removing 58
- fan/heat sink assembly
 - removing 59
- fn key, identifying 13

G

- graphics, product description 2
- grounding guidelines 28
- guidelines
 - equipment 30
 - grounding 28
 - packaging 29
 - transporting 29
 - workstation 29

H

- hard drive
 - illustrated 20, 26
 - precautions 28
 - product description 3
 - removing 43
 - specifications 94
- hard drive cover
 - removing 44
- hard drive holder
 - illustrated 20, 26
- HDMI port
 - identifying 8
- heat sink assembly
 - illustrated 19
 - removing 19
- hinge covers
 - removing 74
- hinges
 - illustrated 23
 - removing 39, 72, 75
- HP PC Hardware Diagnostics (UEFI)
 - using 91
- HP Recovery Manager
 - correcting boot problems 89
 - starting 88

- HP Recovery media
 - creating 85
 - recovery 88
- HP Recovery partition
 - recovery 88
 - removing 89
- I**
- integrated numeric keypad,
 - identifying 13
- internal card
 - product description 4
- J**
- jacks
 - audio-out (headphone)/audio-in (microphone) 8
 - network 8
 - RJ-45 (network) 8
- K**
- keyboard
 - illustrated 18
 - product description 4
- keys
 - action 13
 - esc 13
 - fn 13
 - Windows 13
- L**
- labels
 - Bluetooth 16
 - regulatory 16
 - serial number 15
 - service 15
 - wireless certification 16
 - WLAN 16
- latch, battery release 14
- lights
 - AC adapter and battery light 8
 - caps lock 11
 - drive 7
 - mute 11
 - power 7
 - RJ-45 (network) status 8
- M**
- M.2 solid-state drive
 - specifications 95
- mass storage devices
 - illustrated 25
 - precautions 28
- memory card reader, identifying 7
- memory card, identifying 7
- memory module
 - illustrated 20
 - product description 2
 - removing 48
- microphone
 - identifying 9
 - illustrated 22
 - product description 3
- minimized image recovery 88
- minimized image, creating 87
- model name 1
- mute light, identifying 11
- N**
- network jack, identifying 8
- O**
- operating system 5
- optical drive
 - illustrated 21, 26
 - precautions 28
 - product description 3
 - removing 34
 - specifications 96
- optical drive cable
 - illustrated 20
- optical drive connector
 - removing 53
 - spare part number 53
- optical drive eject button,
 - identifying 7
- optical drive rear bracket
 - removing 35, 36
- optical drive, identifying 7
- original system recovery 87
- P**
- packaging guidelines 29
- plastic parts, service
 - considerations 27
- pointing device 4
- ports
 - HDMI 8
 - product description 4
 - USB 2.0 7
 - USB 3.x SuperSpeed 8
- power button board
 - illustrated 19
 - removing 79
- power button, identifying 12
- power connector cable
 - illustrated 19
 - removing 80
- power connector, identifying 8
- power cord
 - requirements for all countries 97
 - requirements for specific countries and regions 98
 - set requirements 97
- power lights, identifying 7
- power requirements 5
- processor
 - product description 1
- product description
 - audio 3
 - display panel 2
 - Ethernet 4
 - external media cards 4
 - graphics 2
 - hard drive 3
 - internal card 4
 - keyboard 4
 - memory module 2
 - microphone 3
 - operating system 5
 - optical drive 3
 - pointing device 4
 - ports 4
 - power requirements 5
 - processor 1
 - product name 1
 - security 5
 - serviceability 5
 - video 3
 - wireless 4
- product name 1
- product name and number,
 - computer 15
- R**
- recover
 - options 87
- recovery
 - discs 86, 88
 - HP Recovery Manager 87

- media 88
- starting 88
- supported discs 86
- system 87
- USB flash drive 88
- using HP Recovery media 86
- recovery media
 - creating 85
 - creating using HP Recovery Manager 86
- recovery partition
 - removing 89
- regulatory information
 - regulatory label 16
 - wireless certification labels 16
- removal/replacement
 - preliminaries 27
 - procedures 31, 37
- RJ-45 (network) jack, identifying 8
- RJ-45 (network) status lights, identifying 8
- RTC battery
 - illustrated 20
 - removing 47
- Rubber Kit
 - illustrated 21

S

- security cable slot, identifying 7
- security, product description 5
- serial number 15
- serial number, computer 15
- service considerations
 - cables 27
 - connectors 27
 - plastic parts 27
- service labels, locating 15
- serviceability, product description 5
- slots
 - memory card reader 7
 - security cable 7
- solid-state drive
 - illustrated 19
 - removal 50
 - spare part numbers 50
- solid-state drive board
 - illustrated 20, 26
 - removing 51
 - spare part number 51

- solid-state drive holder
 - illustrated 20, 26
 - removing 51
 - spare part number 51
- speakers
 - identifying 14
 - illustrated 20
 - removing 57
- specifications
 - computer 93
 - display 94
 - DVD±RW SuperMulti DL Drive 96
 - hard drive 94
 - M.2 solid-state drive 95
 - optical drive 96
- supported discs, recovery 86
- system board
 - removing 64
 - spare part number 18, 64
- system recovery 87
- system restore point
 - creating 86
- system restore point, creating 85

T

- tools required 27
- top cover
 - illustrated 18
- top cover/keyboard 81
- touch control board
 - illustrated 22
 - removing 73
 - spare part number 68
- TouchPad
 - buttons 10
- TouchPad board
 - removing 55
 - spare part number 55
- TouchPad click board
 - illustrated 18
 - removing 54
 - spare part number 54
- TouchPad zone, identifying 10
- transporting guidelines 29
- traveling with the computer 16

U

- USB 2.0 port, identifying 7
- USB 3.x SuperSpeed port, identifying 8

- USB board
 - removing 56
 - spare part number 20

V

- vent, identifying 8
- video, product description 3

W

- webcam
 - illustrated 22
- webcam cable
 - removing 77
- webcam/microphone cable
 - removing 39, 72
- webcam/microphone module
 - removing 38, 71
- Windows
 - system restore point 85, 86
- Windows key, identifying 13
- Windows tools
 - using 86
- wireless antennas
 - illustrated 23
 - removing 76
- wireless certification label 16
- wireless, product description 4
- WLAN antennas, identifying 9
- WLAN device 16
- WLAN label 16
- WLAN module
 - illustrated 20
 - removing 45
- workstation guidelines 29

