

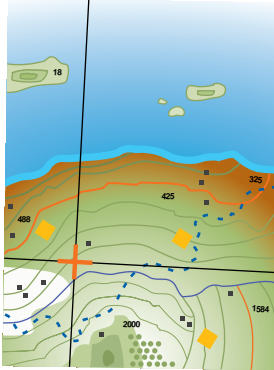

HP DesignJet 3500CP/3000CP Printer



**HEWLETT®
PACKARD**

Quick Reference Guide

© Copyright Hewlett-Packard Company 1998

Manual part number

C4724-90031

Printed in Europe

For trademark information, legal notices, safety notices and warranty information, refer to the HP DesignJet 3000CP User's Guide, manual part number C4723-60121, or HP DesignJet 3500CP User's Guide, manual part number C4724-60011.

Hewlett-Packard Company
Barcelona Division
Avda. Graells, 501
08190 Sant Cugat del Vallès
Barcelona, Spain

Quick Reference Guide

HP DesignJet 3000CP Printer
HP DesignJet 3500CP Printer

Table of Contents

Identifying Printer Parts	3
The Front Panel	4
Entering the Menu System	9
Navigating the Menu System	10
Loading Roll Media	11
Take Up Reel Loading	19
Unloading Media from the Take Up Reel	25
Removing a Roll from the Printer	30
Installing a New Roll into the Printer.	33
Loading sheet media	39
Unloading Sheet Media	41
Replacing the Ink System	43
Removing and Storing Partially Used Ink Systems	59
Solving Ink System Problems	64
Message Explanations and Actions	83

Identifying Printer Parts

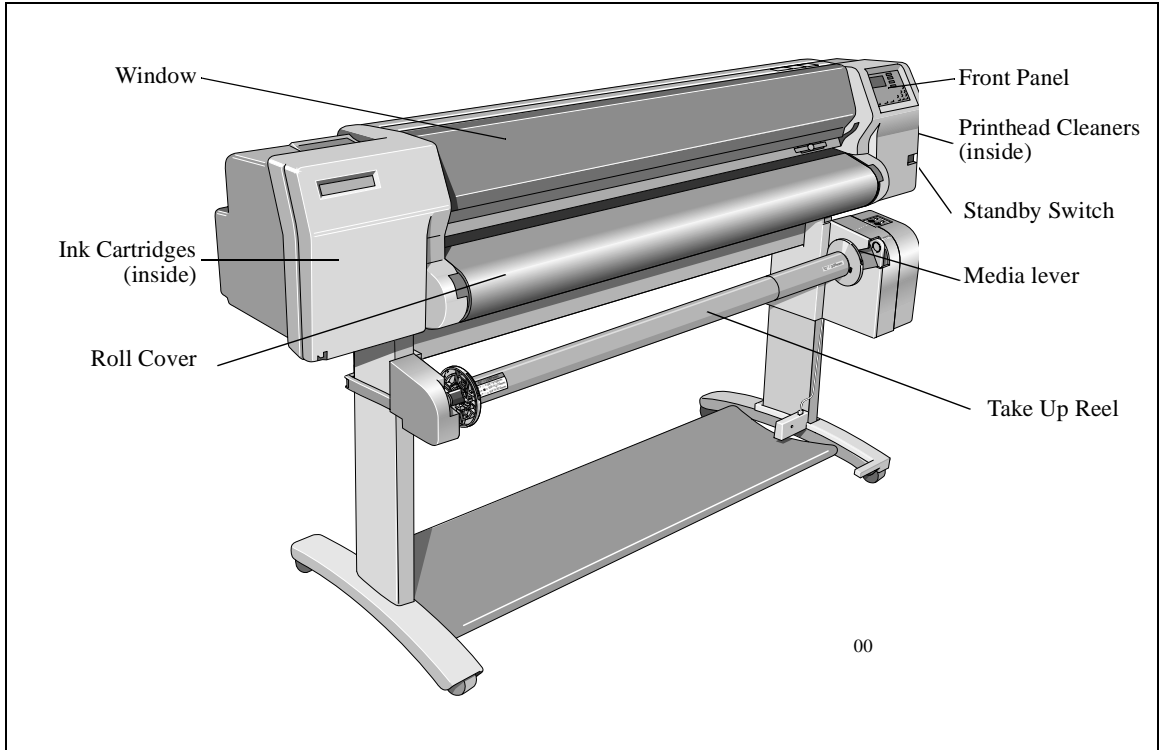

The Front Panel

The front panel of the printer is made up of four functional areas.

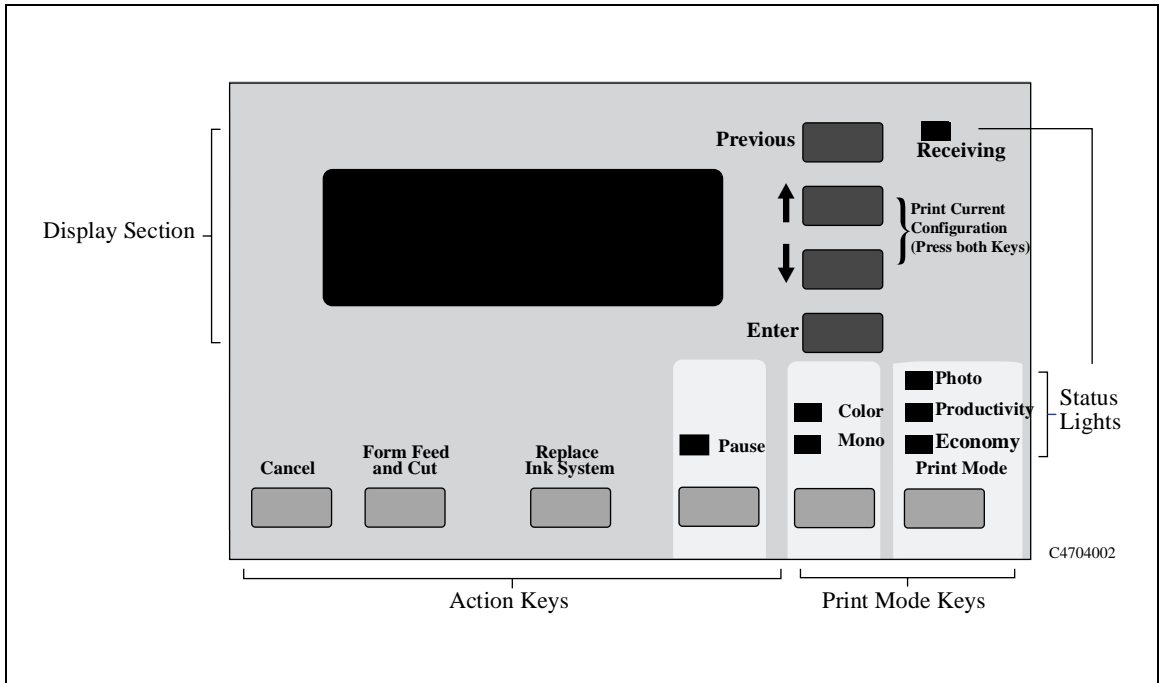

Display Section

The display section of the front panel consists of the two-line display and the four display keys to its right (**Previous**, **↑**, **↓** and **Enter**)

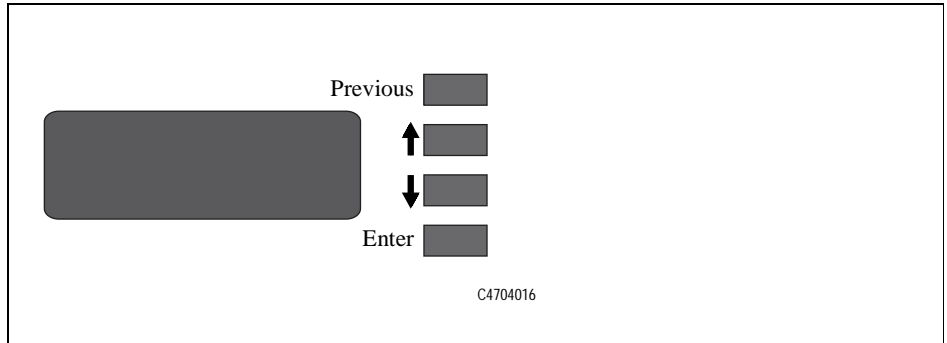

- The display is used for displaying:
 - Menus used to configure the printer.
 - Messages about printer status, required actions, or errors.
- Use the display keys to navigate the menu system and select menu options. You also use the display keys to respond to messages.

See 83, *Message Explanations and Actions* for detailed descriptions of error and status messages.

The Front Panel

Action Keys

- Press **Cancel** to cancel the current printer operation.
- Press **Form Feed and Cut** to advance and cut media.
- Press **Replace Ink System** to replace ink system components.
- Press **Pause** to pause the printer.

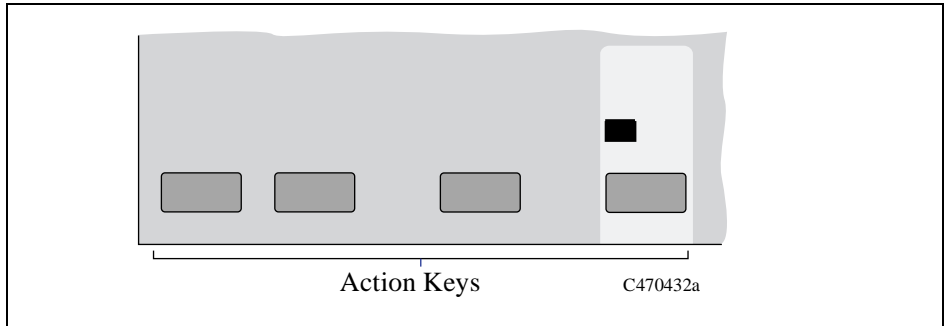

See chapter 7, *Managing Your Prints*, in the user's guide for detailed information on the use of these keys.

**Print Mode
Keys**

- Use the **Color/Mono** key to select whether to print in color or monochrome (black and grayscale).
- Use the **Print Mode** key to select the print mode mode you want.

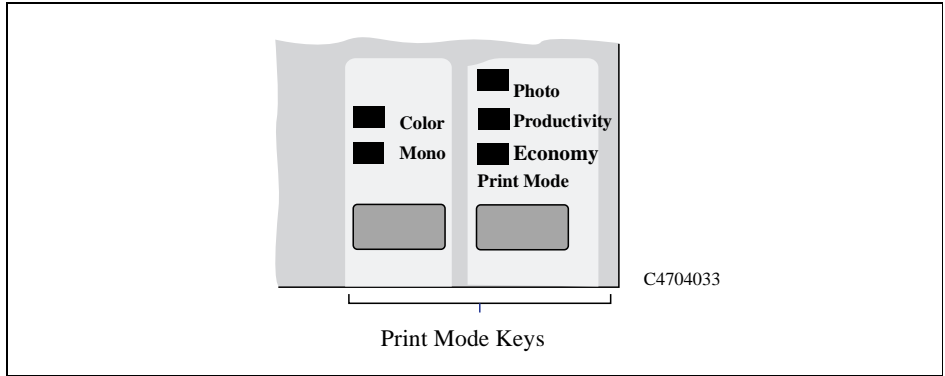

See chapter 6, *Controlling the Overall Appearance of a Print*, in the user's guide for detailed information on the use of these keys.

The Front Panel

Status Lights

The status lights provide status information about the current configuration and state of the printer.

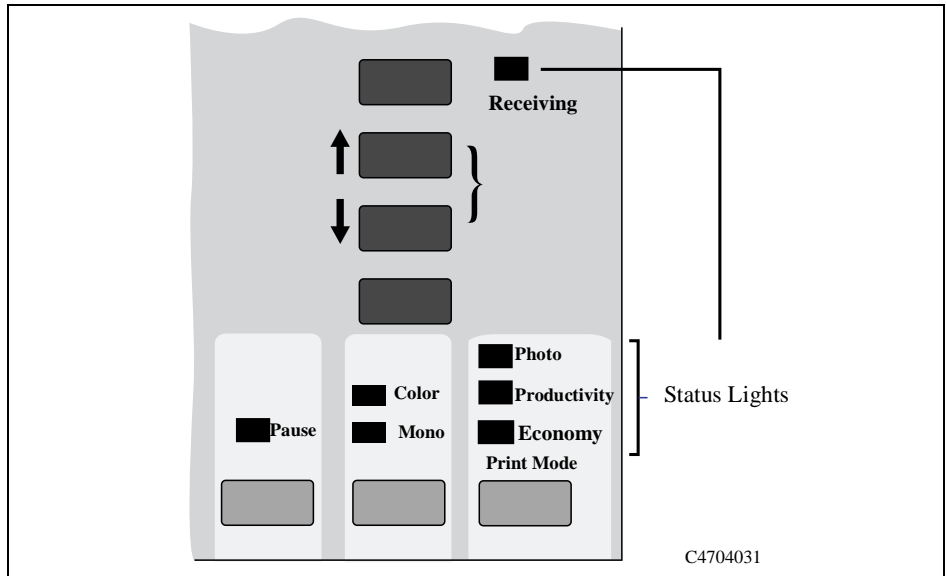

Entering the Menu System

1 Make sure a status screen is displayed, as shown in the example on the right.

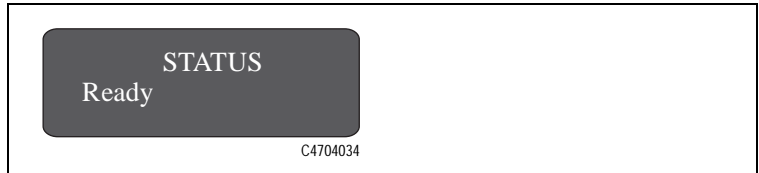

2 Press the **Enter** key.

3 You may not be able to access the menu system immediately, if the current task overrides it. If this happens, wait until the task is completed and try again.

Either the **SHORT MENU** screen

A screenshot of a short menu screen. The screen is dark gray with white text. At the top, the words "SHORT MENU" are displayed in a larger font. Below them, the words "Queueing & Nesting" are displayed in a smaller font. In the bottom right corner, the code "C4704008" is visible. A white line points from the text "Only menus shaded yellow in front-panel menus print are accessible in Short Menu mode. (Shaded gray if printing in monochrome)." to the "SHORT MENU" text.

Only menus shaded yellow in front-panel menus print are accessible in Short Menu mode. (Shaded gray if printing in monochrome).

or the **FULL MENU** screen

A screenshot of a full menu screen. The screen is dark gray with white text. At the top, the words "FULL MENU" are displayed in a larger font. Below them, the words "Queueing & Nesting" are displayed in a smaller font. In the bottom right corner, the code "C4704008" is visible. A white line points from the text "All menus are accessible." to the "FULL MENU" text.

All menus are accessible.

is displayed, with the Queueing & Nesting option shown.

Navigating the Menu System

Press **Previous** to display the previous menu level, without changing any menu selections (equivalent to moving left [\leftarrow]¹ one column in the Front-Panel Menu print).

Press \uparrow to scroll up, or \downarrow to scroll down through the options in a menu (equivalent to moving up [\uparrow] or down [\downarrow] a column in the Front-Panel Menu print).

The option list is continuous, allowing you to move from the bottom to the top by pressing \downarrow or from the top to the bottom by pressing \uparrow .

Press **Enter** to:

- select an option and move to the next menu level, when in the menu system (equivalent to moving one column to the right [\rightarrow] in the Front-Panel Menu print).
- Change the printer's configuration to the displayed choice, that is, selecting an option from the lowest level menu [\downarrow].

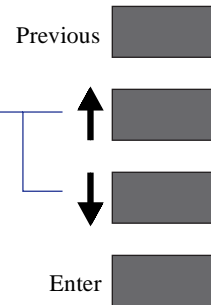

C4704006

NOTE: A \rightarrow character in a menu option box indicates that another level of menu is available.

Loading Roll Media

To start this procedure you need to have a roll of media installed on to the printer spindle. See page 33, *Installing a New Roll into the Printer*.

- 1** Check the leading edge as it unwinds from the spool. If it is not evenly cut or if it is skewed (not perpendicular to the guides), continue with the next procedure. If the media is cut correctly go to step 3
 - a** Pull the media over the top of the machine and lay it over the cutting track.
 - b** Use the knife in the pocket located on the back of the printer to cut off the first few inches of the media.
 - c** Retract the blade and return the knife to its pocket.

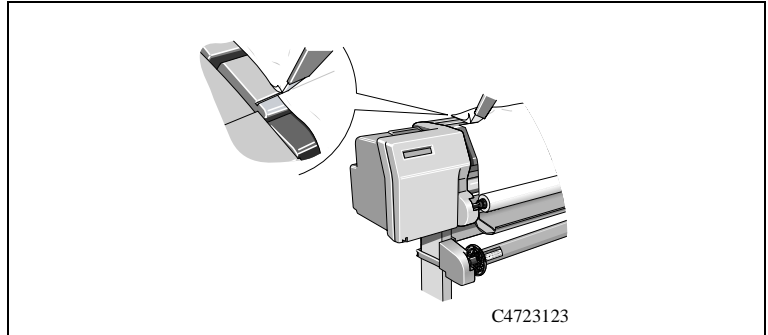

Loading Roll Media

- 2 Make sure the media lever is in the raised position.
- 3 Open the roll cover and pull out the media.

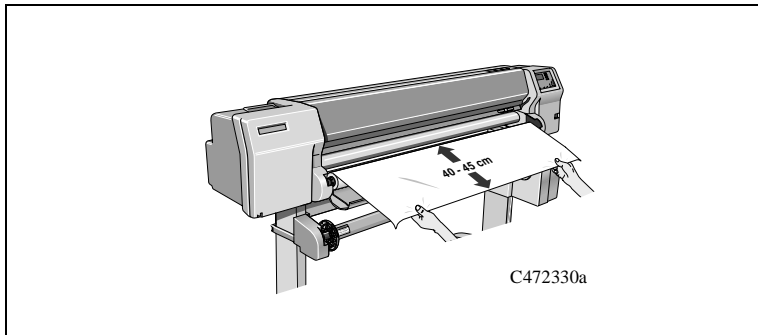

- 4 Position the media.

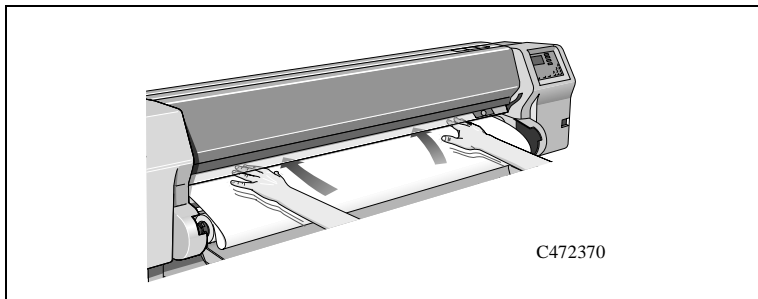

- 5 Insert the media into the printer.

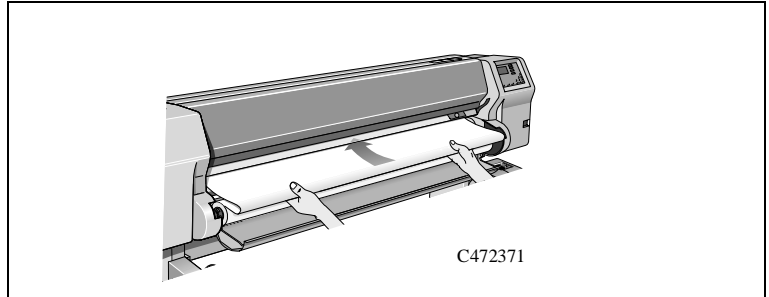

- 6 When the media is fed into the printer as far possible the media button light comes on. The front panel displays:

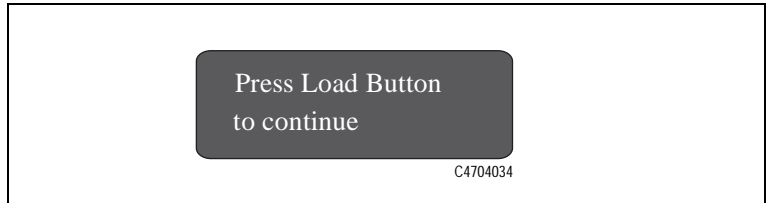

- 7 Make sure the media is aligned with dashed line as shown.

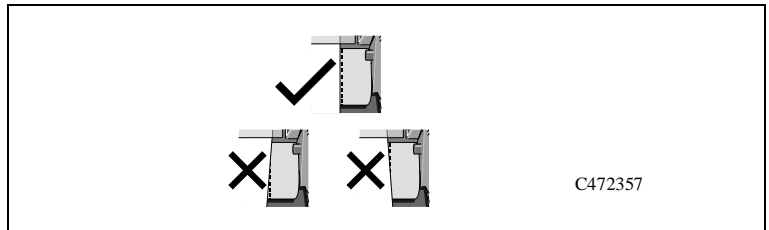

Loading Roll Media

- 8 Press the media button and the media will be fed into the printer.

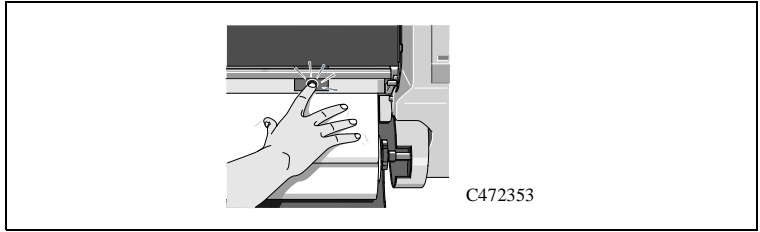

- 9 Press the ↓ key next to the front-panel display to indicate you are loading a roll.

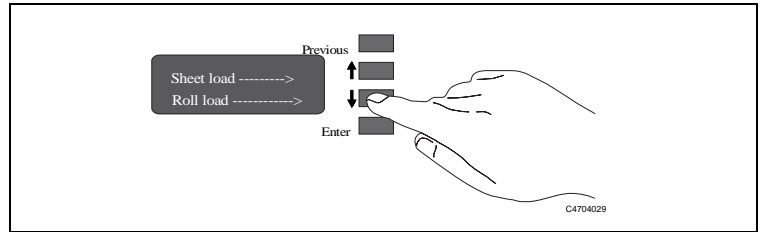

- 10 Use the ↑ and ↓ keys until the display shows the type of media you are loading and then press the **Enter** key.

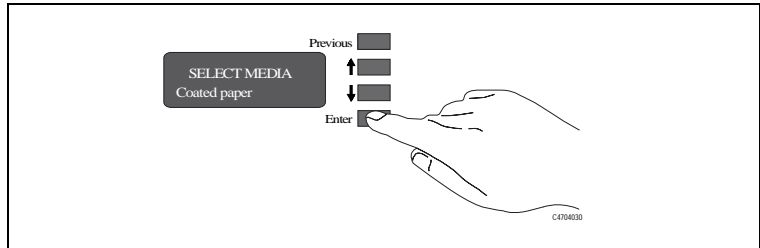

11 Align the media.

- a When the front panel displays “**Lower Lever**”. Lower the media lever.

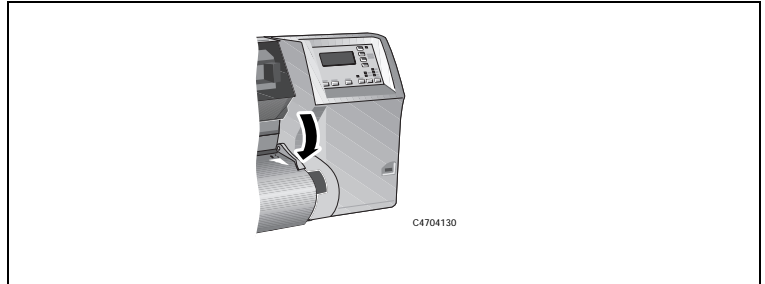

- b Wind the media stop in the direction of the arrow shown. This is to take up any slack in the roll before aligning the media.

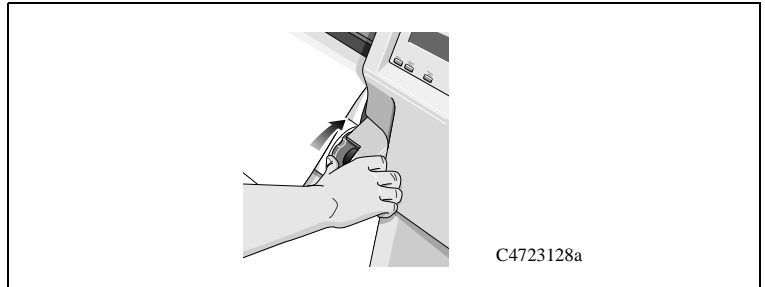

- c The front panel displays:

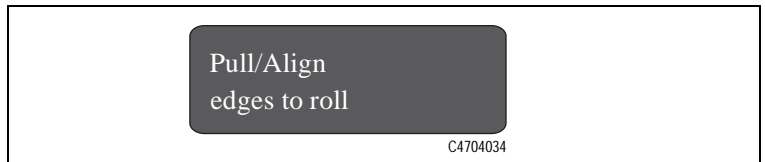

Loading Roll Media

- 12** Take hold of the edges of the media now extending from the exit slot and pull the media toward you until taut. Then align the left and right edges of the media, so that they are flush with the edges of the roll

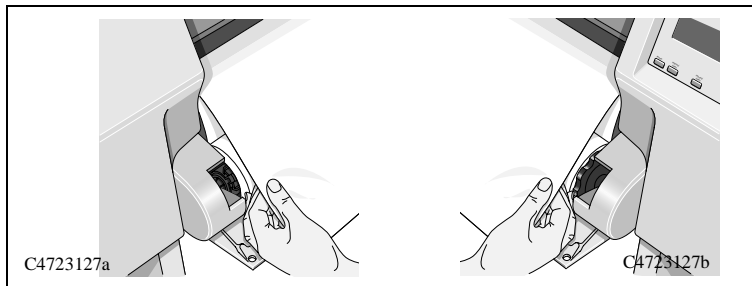

- 13** When you have aligned the media lift the lever.

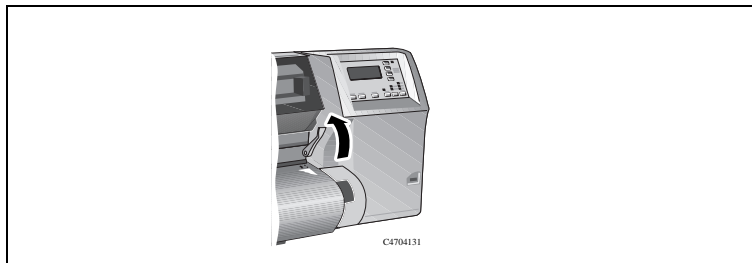

14 The printer checks that the media is aligned properly. If the alignment is successful the front panel displays

15 Close the roll cover and press the ↓ key to continue.

16 When you close the roll cover you have two options, depending on the status of the Take Up Reel:

- a** If the Take Up Reel is turned **off** the printer is now ready to print.
- b** If the Take Up Reel is turned **on** and you want to load the Take Up Reel proceed to the next step.

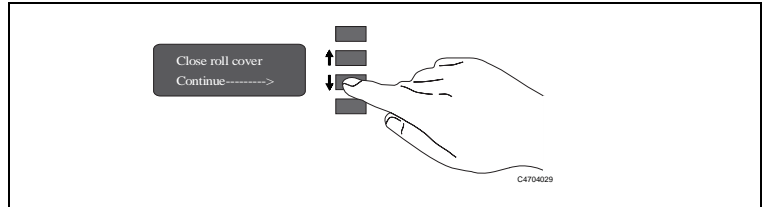

Loading Roll Media

17 If your media is not straight or has been damaged press the ↑ key. If you want to continue use the use the ↓ key.

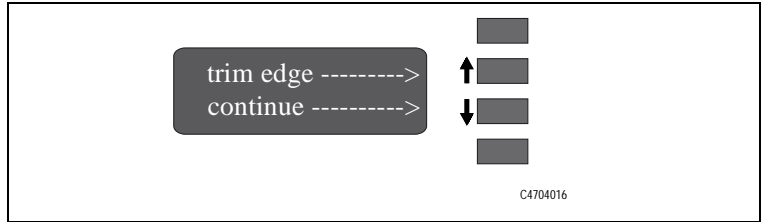

Take Up Reel Loading

To start this procedure you need to have a roll of media installed into the printer see page 33, *Installing a New Roll into the Printer.* and 11, *Loading Roll Media.*

CAUTION

Using Back-lit media with a separate slip sheet is not recommended for use with the Take Up Reel.

- 1 Move the leading edge of the media to half way down the Core Tube. To move the media down use the ↓ key as shown. If the media has gone too far (i.e. passed the Core Tube) use the ↑ key to move the media back up

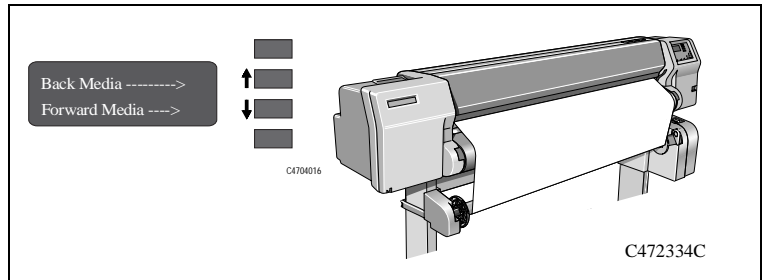

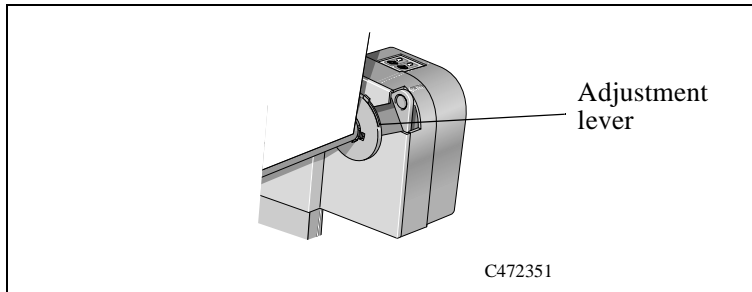

Take Up Reel Loading

- 2 Move the adjustment levers on the media guides to the unlocked position 

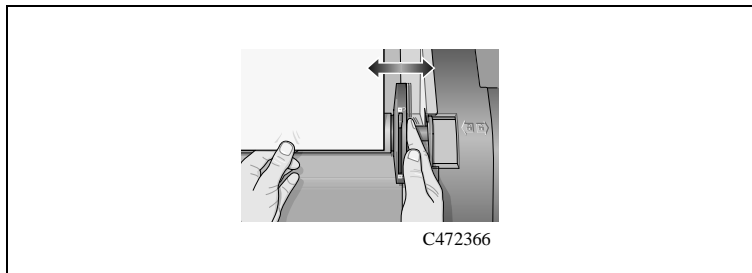

- 3 The two media guides and core must be positioned on the spindle so that the media is in the center, between the media guides. Adjust the media guides as shown.



- 4 When the adjustment is made, pull the adjustment levers to the locked position. 

- 5 Pull the media down taut to the position shown. Do not attempt to pull more media from the printer, if you need more media use the front panel.

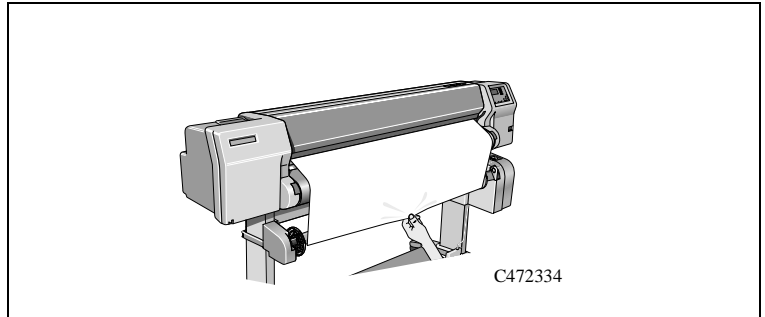

- 6 Use a small amount of sticky tape (see note below) to attach the media to the core. Use three strips, one at each side of the media and one in the middle. Stick the middle one first.

NOTE: Use only tape which will not tear the media when it is removed later.

NOTE: To avoid the media skewing as it is wound onto the Core tube, ensure the media is straight when it is attached

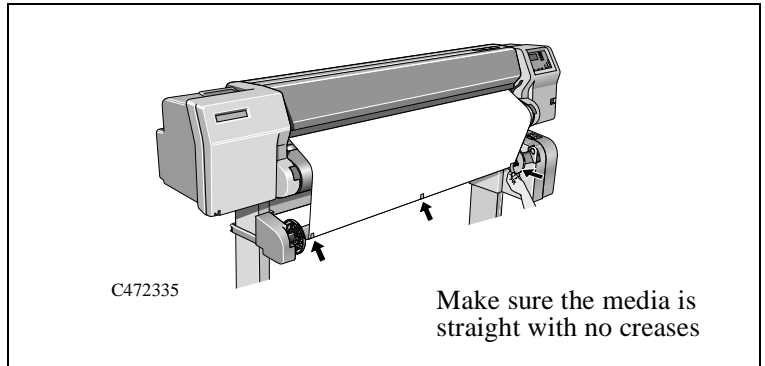

Take Up Reel Loading

7 Press the ↓ key to advance the media. Enough media should be advanced so that the media can wrap at least once around the core so securing it fully onto the Take Up Reel

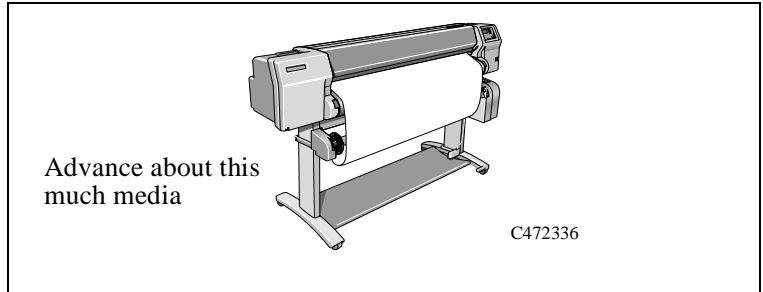

8 Important: Press the media wind button on the Take Up Reel panel indicated to wind the media once around the core.

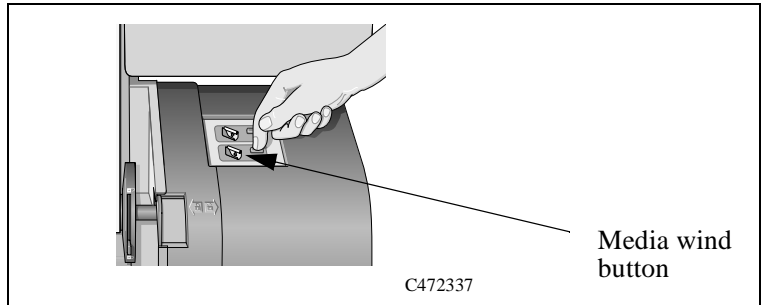

Take Up Reel Loading

9 It is important that the Media Weight is the same width as the media you are using. By matching color coded lengths of plastic tube, you can make a Media Weight for different widths of standard media sizes: 24", 36", 42", 50" and 54".

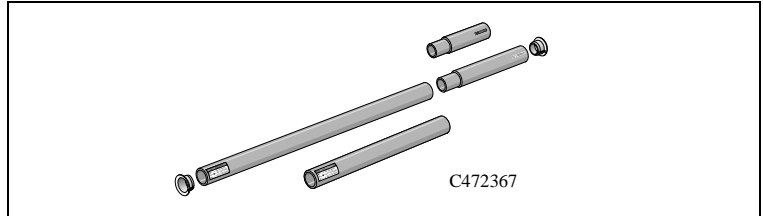

10 Carefully insert the Media Weight, ensure the end caps are installed and extend over the edges of the media.

NOTE: It is important that the media weight is inserted. The Take Up Reel will not function properly without it

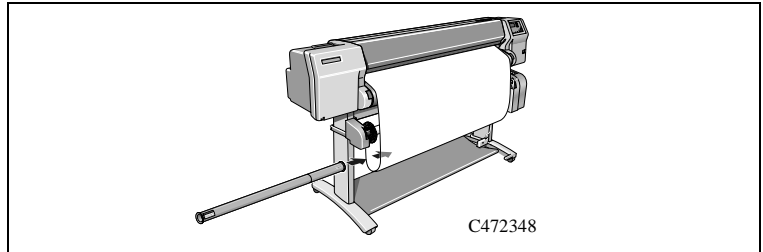

11 Press **Enter**.

Take Up Reel Loading

NOTE: When the Take Up Reel is in operation it is important to ensure that the Take Up Reel sensor is not blocked.

- 12** Shown is how the printer should look when it is in operation. As media is fed from the printer it drops down in a loop and up into the Take Up Reel spindle.

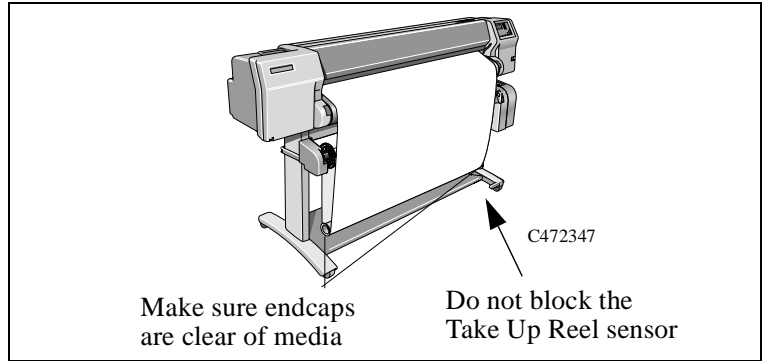

Unloading Media from the Take Up Reel

To remove media from the printer see page 30, *Removing a Roll from the Printer*.

To unload roll media from the Take Up Reel perform the following procedure.

NOTE: Before unloading media ensure the ink is dry; see the Use's Guide, *Drying time (Take Up Reel = on)*.

- 1 Press the Form feed and cut button on the front panel.

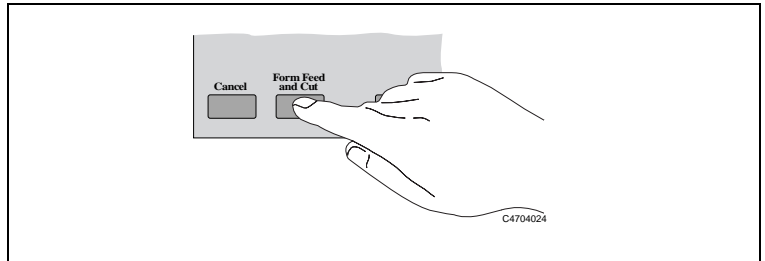

Unloading Media from the Take Up Reel

2 Important: Remove the Media Weight shown. It may help you to remove the end-caps first.

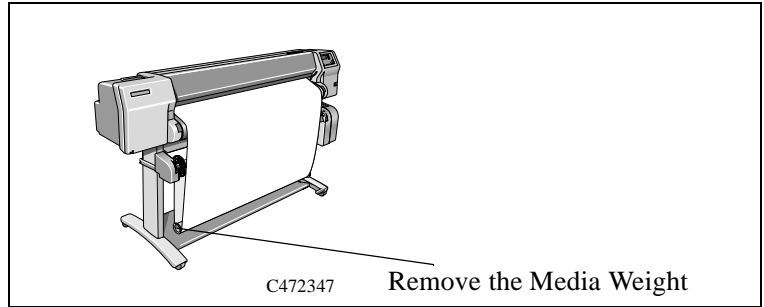

3 The front panel displays:

4 Press ↓ key as shown to continue.

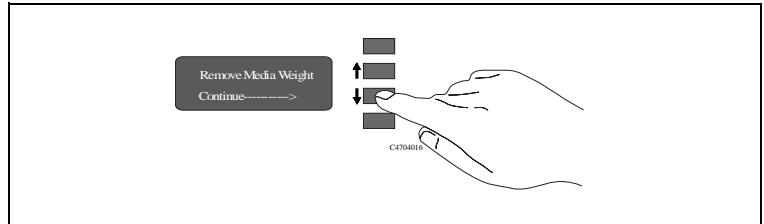

Unloading Media from the Take Up Reel

- 5 Press the media wind button shown to wind the media hanging down onto the Take Up Reel. The front panel displays:
- 6 After winding up the Take Up Reel press the ↓ key. The cutter cuts the media.
- 7 Press the media wind button again on the Take Up Reel until the media is wrapped around the core.

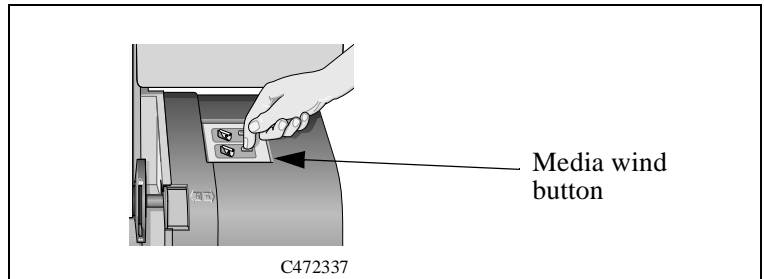
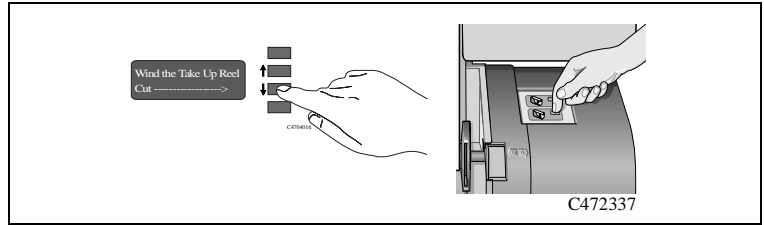

Unloading Media from the Take Up Reel

8 Slide open the spindle lock on the right hand side of the Take Up Reel.

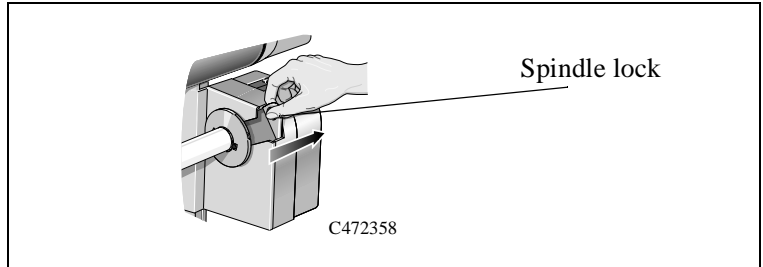

9 Remove the Take Up Reel spindle.

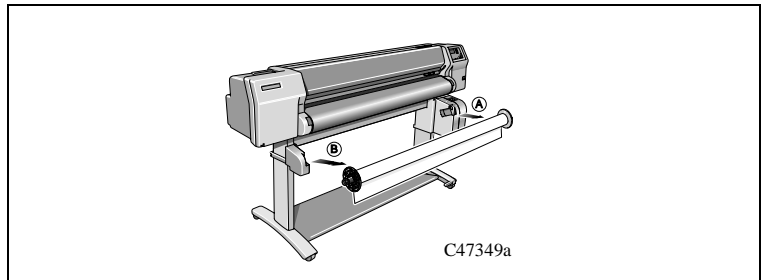

Unloading Media from the Take Up Reel

- 10** Remove the Take Up Core from the Take Up Reel spindle.

To remove roll media from the printer perform the following procedure.

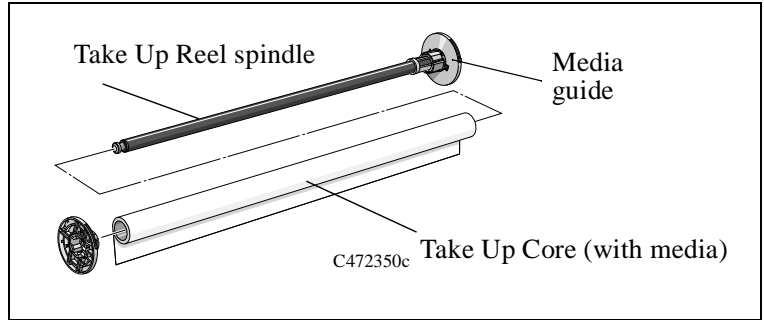

Removing a Roll from the Printer

To unload media from the Take Up Reel see page 25, *Unloading Media from the Take Up Reel*.

- 1 .If the media button light is off, press Form Feed and Cut on the front panel.
- 2 If the media button light is on, press the media button.

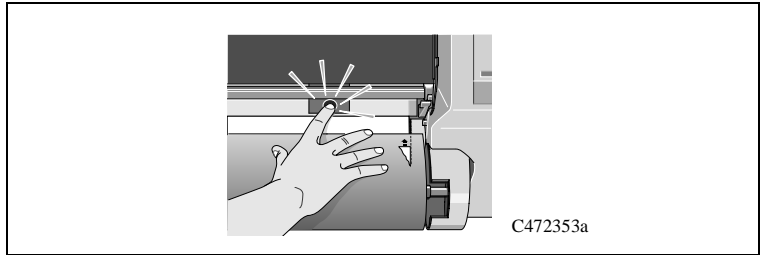

- 3 The front panel displays:
- 4 Open the roll cover and gently pull the media from the printer.



Removing a Roll from the Printer

5 Remove the old roll by pulling firmly on each end of the spindle, A then B.

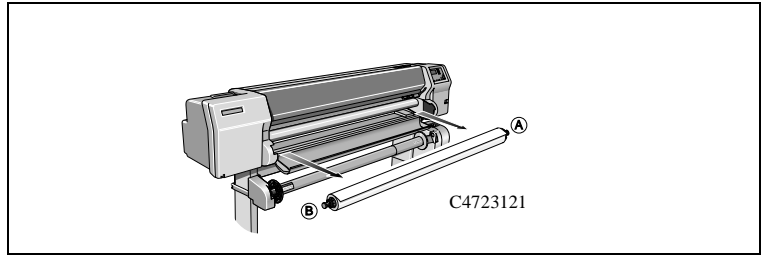

Removing a Roll from the Printer

6 Rest the old roll upright on the floor so that the media stop (A) is on top. Pull out the media stop A and the spindle. Pull out the endcap (B) from the other end of the old roll.

NOTE: Alternatively if the media roll is very long, rest it horizontally on a table and unload the media on the table.

7 You have completed removing the old roll media from the printer. If you are not immediately loading another roll of media into the printer, replace the endcap on the spindle and place the spindle back in the printer.

To load a new roll of media, continue with the next section, 33, Installing a New Roll into the Printer.

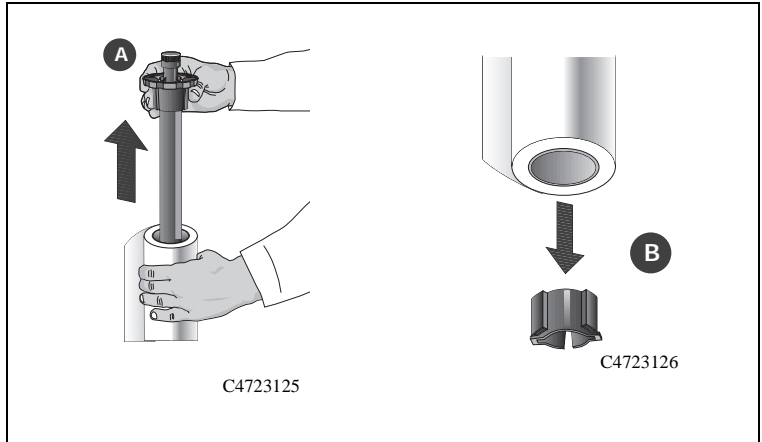

Installing a New Roll into the Printer.

- 1 If an empty spindle is installed in the printer, open the roll cover and remove the empty spindle by pulling firmly on each end, A and then B as shown.
- 2 Remove the new roll from its wrapping.

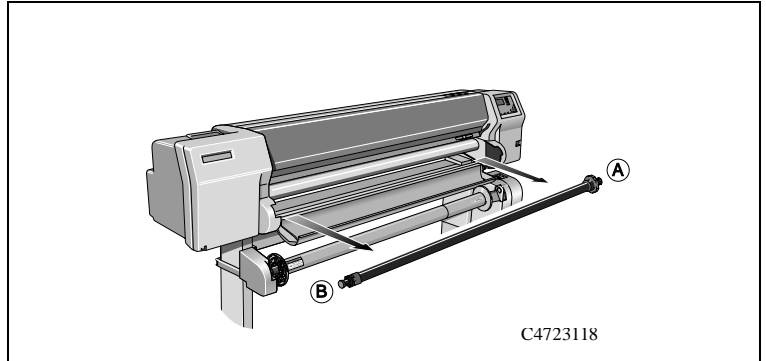

Installing a New Roll into the Printer.

3 Place the spindle vertically on the floor, with the media stop at the bottom. Remove the end cap from the top of the spindle, and slide the new roll onto the spindle. The leading edge of the media must wind clockwise as shown.

NOTE: Alternatively if the media roll is very long, rest it horizontally on a table and load the media on the table.

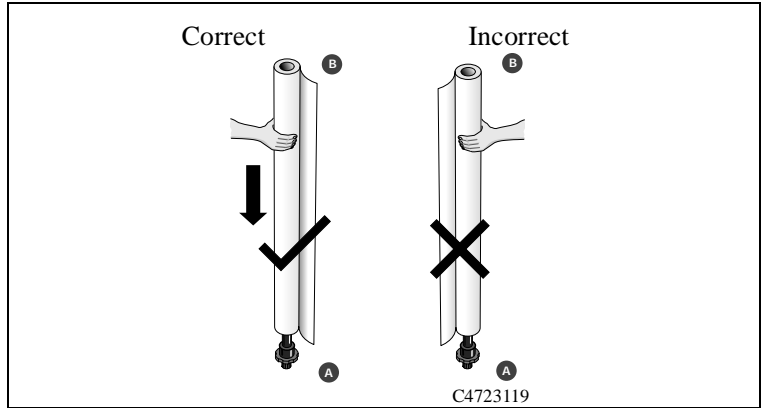

4 Push the end cap in, making sure that the tabs are flush against the ends of the roll. Push it far enough to be firm, but do not use excessive force as this may result in broken tabs.

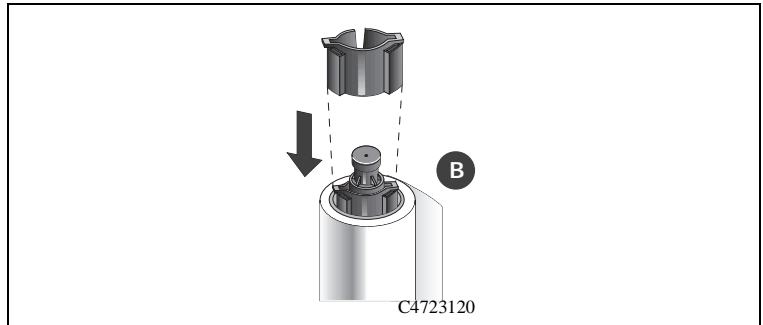

Installing a New Roll into the Printer.

5 Insert the spindle so that the large media stop (A) is to the right and the small endcap (B) to the left. Push in firmly on both ends. Make sure the media remains flush against the media stop.

NOTE: The media must be positioned on the roll as shown above.

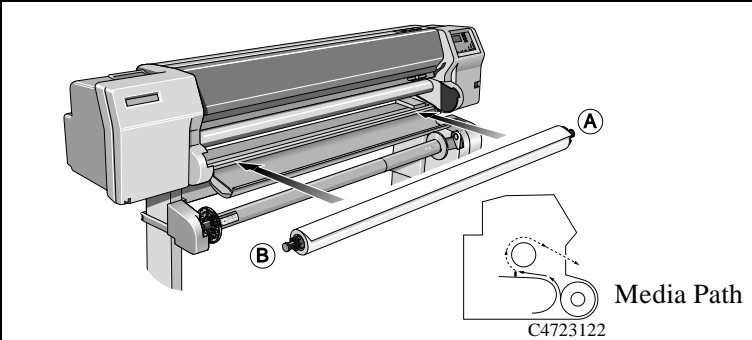

Changing the Core Tube on the Take Up Reel

The Core tube on the Take Up Reel must be the same width as the media you are using. To change the core perform the following procedure.

- 1 Slide open the spindle lock on the right hand side of the Take Up Reel.

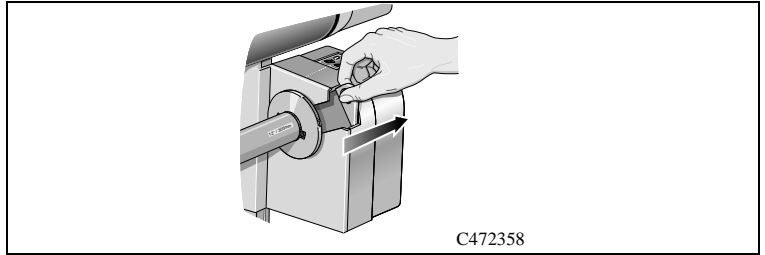

- 2 Remove the Take Up Reel spindle from the printer as shown by pulling firmly on each end of the spindle, A then B.

- 3 Remove the left-hand media guide.

- 4 Remove the old Take Up Core.

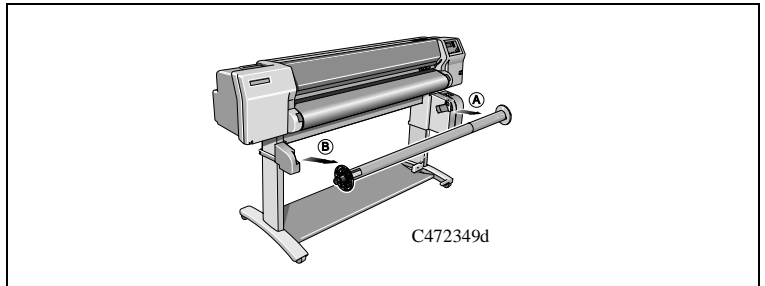

Changing the Core Tube on the Take Up Reel

- 5 Install the new Core you have chosen onto the spindle and re-install the left hand media guide.

NOTE: You can also use an empty cardboard tube to replace the plastic Take Up Core that was supplied with your printer.

- 6 It is important that the Take Up Core is the same width as the media you are using. By matching color coded lengths of plastic tube, you can make a Take Up Core for different widths of standard media sizes: 24", 36", 42", 50" and 54".

NOTE: Ensure the Take Up Core is pushed firmly into both media guides.

NOTE: If you want to use a three inch cardboard core then use the 3 inch core adaptors shown.

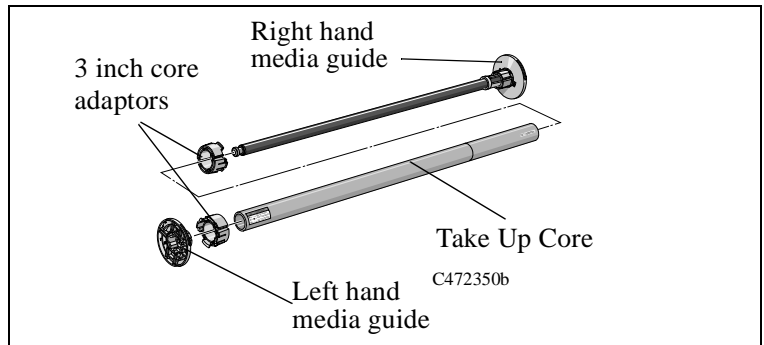
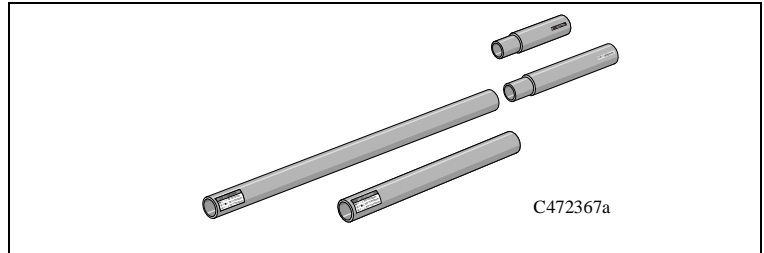

Changing the Core Tube on the Take Up Reel

7 Install the Take Up Reel spindle into the printer by pushing firmly on each end of the spindle, A then B.

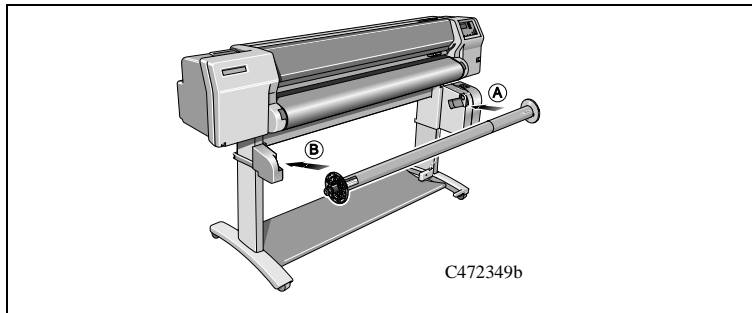

8 Slide shut the spindle lock on the right-hand side of the Take Up Reel.

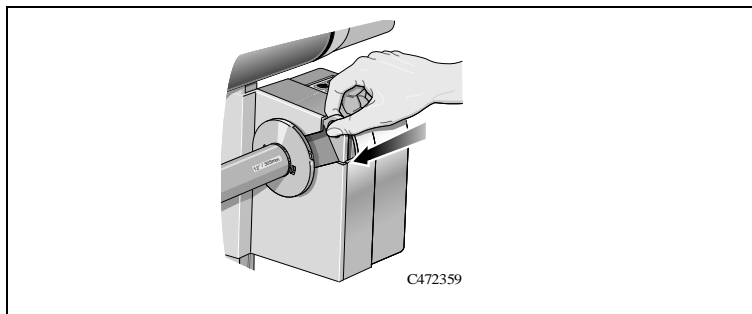

Loading sheet media

- 1 You cannot load sheet media if roll media is loaded. If roll media is loaded refer to 30, *Removing a Roll from the Printer.*
- 2 Make sure the media lever is in the raised position and the roll cover is closed.
- 3 Holding the media at its sides, align the right edge with the perforated line on the entry platen. When the media is fed into the printer as far as possible the media button light comes on.

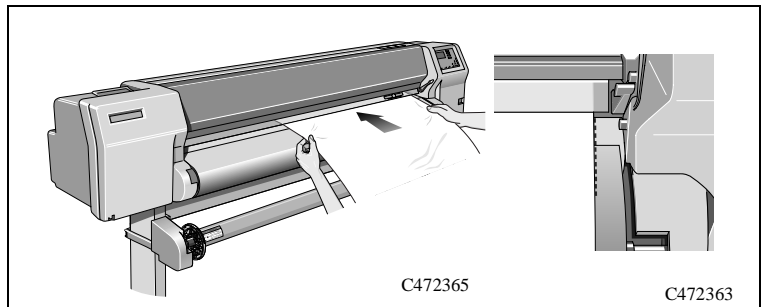
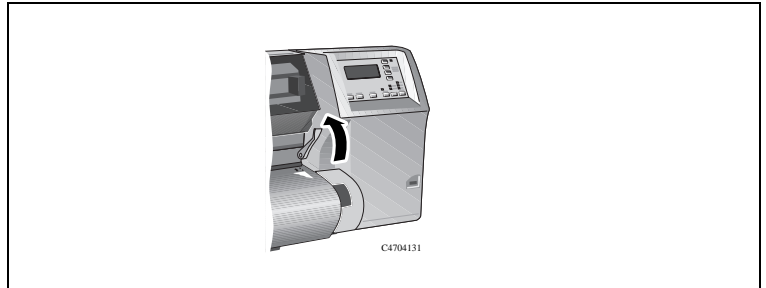

4 When you are satisfied that the media is positioned straight, press the media button. Only let go of the media when the printer begins to pull it in.

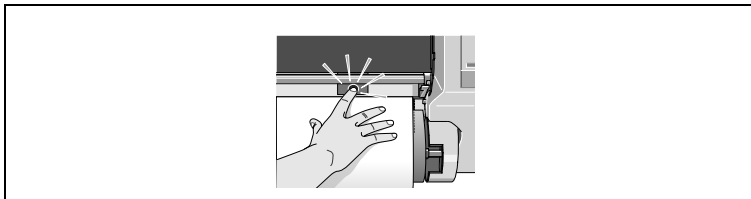

5 Press \uparrow next to the front-panel display to indicate you are loading a sheet

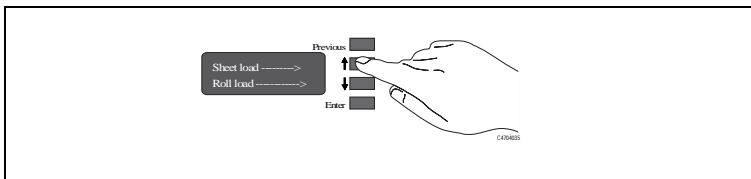

6 Using the \uparrow and \downarrow keys until the display shows the type of media you are loading*. Then press the **Enter** key.

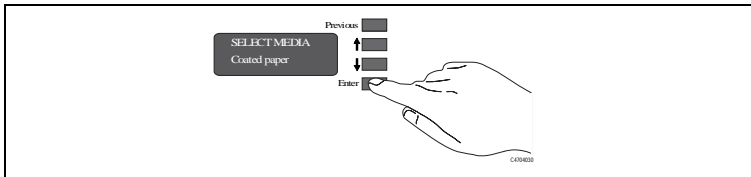

7 The printer moves the sheet in and out to check its size and alignment, and then advances to the start of the page.

Unloading Sheet Media

- 1 Wait until the appropriate drying time has passed (see the User's Guide. No drying time is necessary for some combinations of media types and print modes).
- 2 Press the Form Feed and Cut button

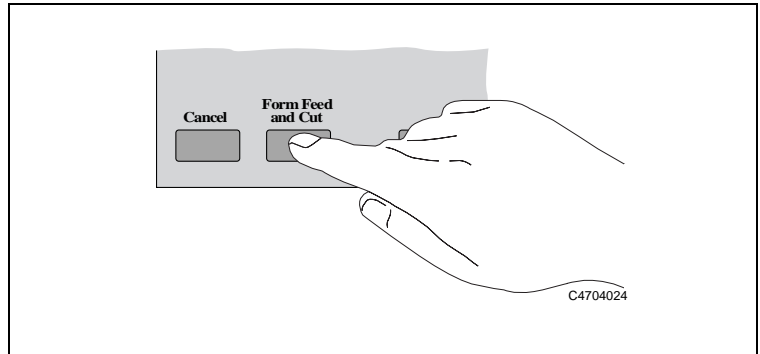

Unloading Sheet Media

- 3 Gently pull the sheet from the printer.

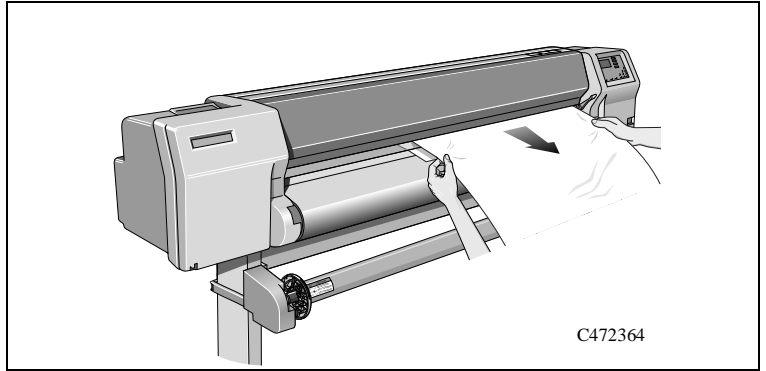

Replacing the Ink System

WARNING



Keep hair, jewelry, clothing, and other foreign objects away from the printer mechanisms.

Keep used ink components out of the reach of children.

CAUTION

Do not touch, wipe, or attempt to clean the printhead nozzles or contacts. This can clog and damage the printhead.

◆ To start the replacement procedure, press the **Replace Ink System** key on the front panel.

The front-panel display will prompt you to replace components in the following order:

- 1 Remove and replace printheads.
- 2 Remove and replace printhead cleaners.
- 3 Remove and replace ink cartridges.

NOTE: It very important that you do not mix ink systems up. The UV ink systems and other non-UV ink systems are not compatible. Contamination of one ink system with the other will result in you having to replace both the ink systems.

Replacing the Ink System

The components of the ink system are numbered to match the sequence in which they must be installed. The number is printed on the printhead cleaner and ink cartridge, and on the sleeve containing the printhead.

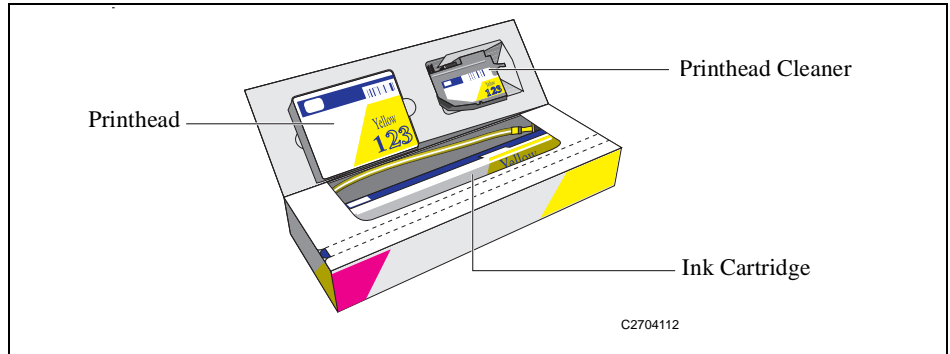

Remember:

- Always change all three components for each ink color system at the same time.
- Use only the components that come together in their box. Never mix the components with the same or different colors from other boxes.
- Never mix components of different ink types.

NOTE

Follow the instructions in the front-panel display. If there are any problems during the installation, the printer will give you instructions in the front-panel display. Descriptions of all front-panel messages and instructions on what to do are listed in chapter 12, *Front-Panel Messages*, of the user's guide.

1 Removing and Replacing Printheads

NOTE: Do not open the window before the “Open window to access printheads” message is displayed. Follow the instructions in the front-panel display. If there are any problems during the installation, the printer will give you instructions in the front-panel display. Descriptions of all front-panel messages and instructions on what to do are listed in chapter 83, *Message Explanations and Actions*.

- 1 When the printer carriage stops and the front panel displays the message “*Open window to access printheads,*” open the window of the printer.

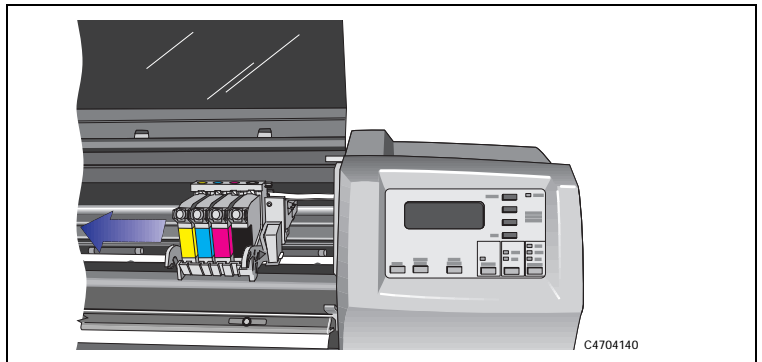

After you open the window, the printer will display the following message on the front panel. Blinking indicators show which printheads must be replaced. In the following example, the yellow printhead needs to be replaced.

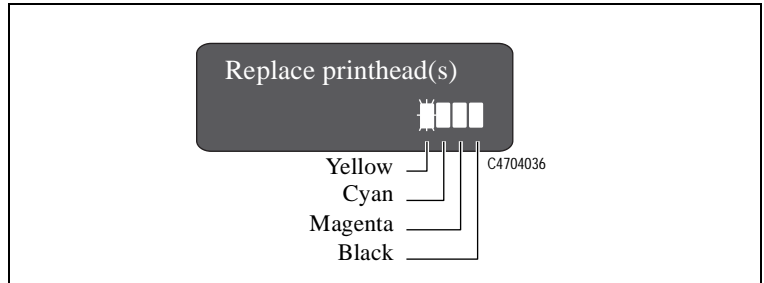

- 2 Press down lightly on the printhead you are replacing and pull it toward you, removing it from its stall. Discard the used printhead.

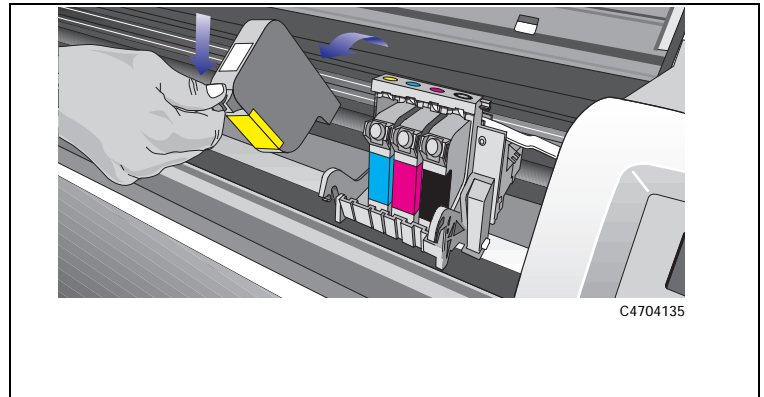

Replacing the Ink System

- 3 Take the new printhead and remove the colored protective tape from the printhead's nozzles.

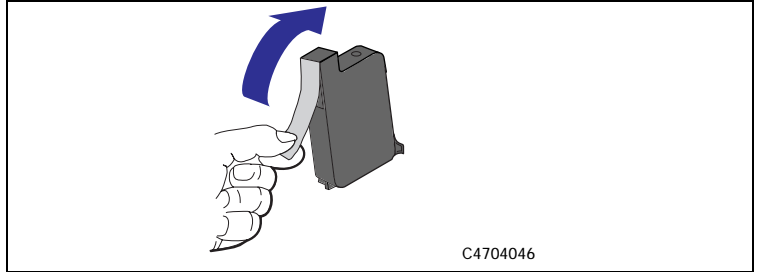

- 4 Insert the printhead into the stall with the color dot that matches the color of the printhead label. Press down lightly and push the printhead away from you (toward the back of the cradle) until it snaps into place.

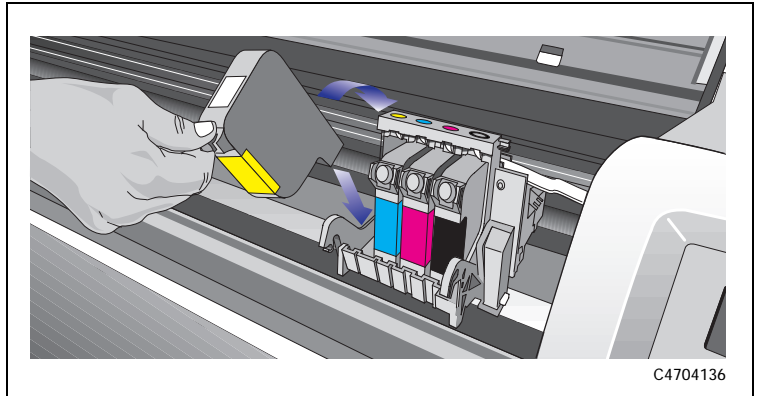

5 Repeat steps 2 through 4 for any additional printheads you need to replace.

When you have finished replacing printheads, the printer front panel displays the message “*Close window to continue*”.

6 Close the window of the printer.

The front panel will display the message “*Open right door to access head cleaners*”.

Continue with the next procedure, *Removing and Replacing the Printhead Cleaner*.

2 Removing and Replacing the Printhead Cleaner

1 Open the right door on the printer.

After you open the right door, the front panel displays the message shown. The blinking indicators show which printhead cleaner(s) must be replaced. In this example the yellow printhead cleaner needs to be replaced.

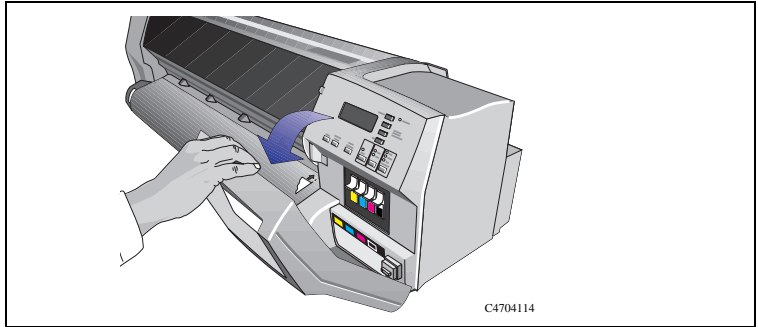

- 2** Press down on the printhead cleaner handle and pull it out of the printer. Discard the used printhead cleaner.

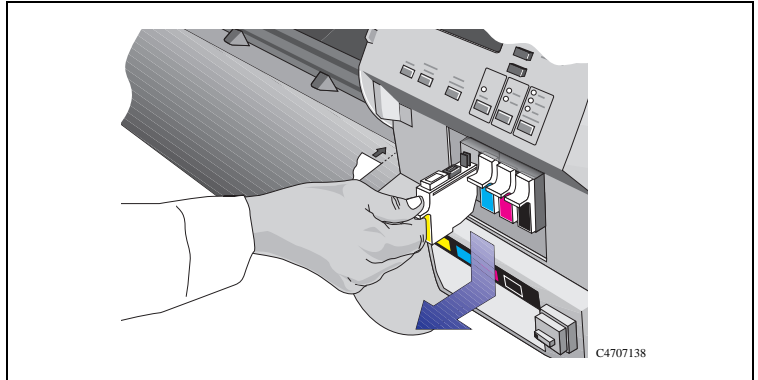

- 3** Insert the new printhead cleaner into the matching color-coded slot in the printer.

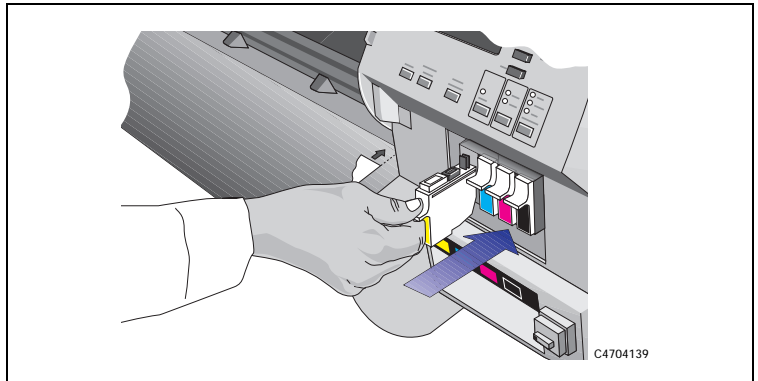

- 4** Repeat steps 2 and 3 for any additional printhead cleaners you need to replace.

Replacing the Ink System

- 5 Close the right door on the printer.

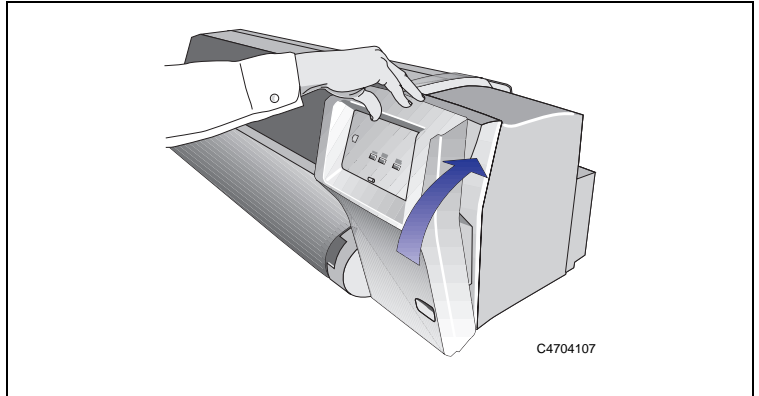

The front panel will display the message “*Open left door to access ink cartrg.*”.

Continue with the next procedure, *Removing and Replacing the Ink Cartridge*

3 Removing and Replacing the Ink Cartridge

1 Open the left door on the printer.

After you open the left door, the front panel displays the message shown. The blinking indicator shows which ink cartridge must be replaced. In this example the yellow ink cartridge needs to be replaced.

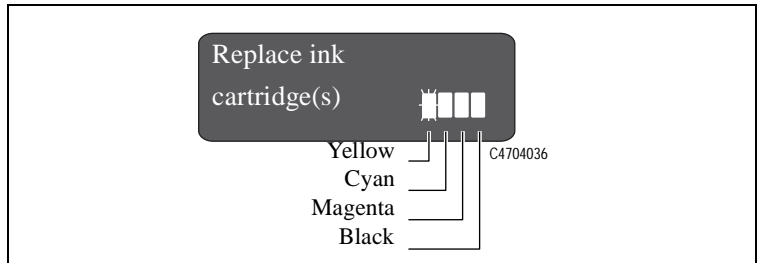
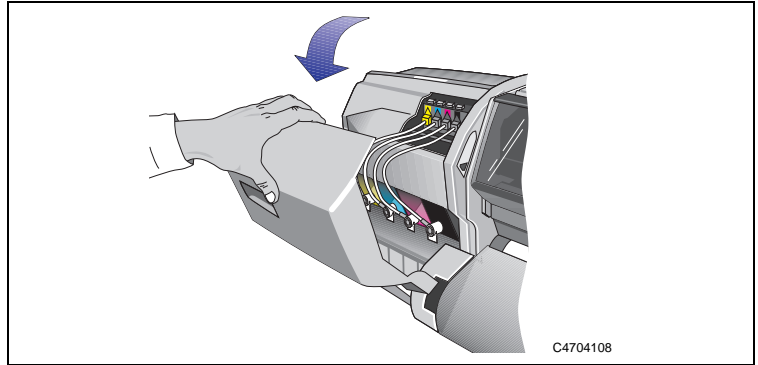

Replacing the Ink System

- 2 While pressing down on the quick-release button (1), unplug the ink cartridge tube by pulling the tube connector away from the printer (2).

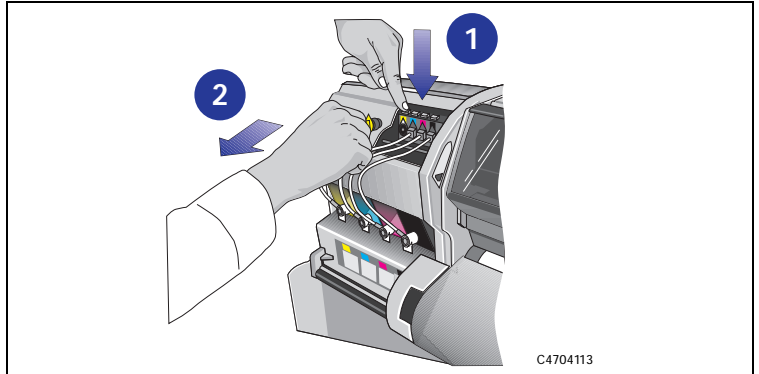

C4704113

CAUTION

Never pull the ink cartridge out by the tube or connector. This may cause the ink cartridge to leak. Always grasp the body of the cartridge when removing or installing.

- 3 Remove the used ink cartridge from the slot in the printer.
Discard the used ink cartridge.

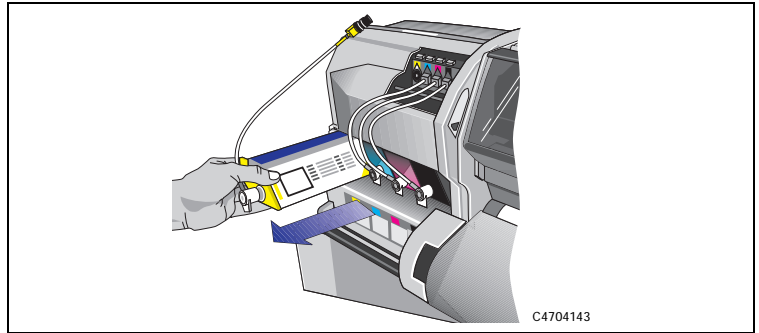

Replacing the Ink System

- 4 Insert the new ink cartridge into the slot in the printer, making sure that you match the ink color with the color code on the printer.

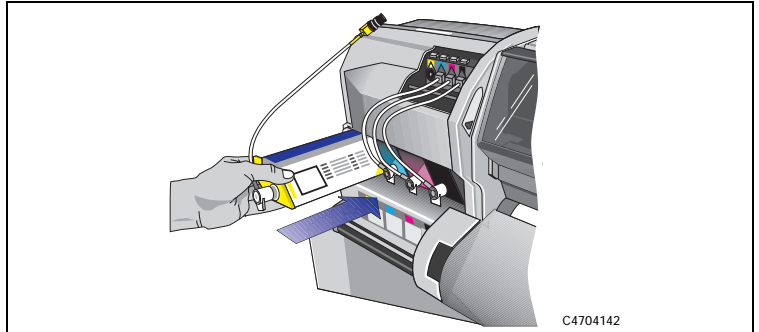

- 5 Plug the valve on the ink cartridge tube into the connector on the printer making sure that you match the valve color with the color code on the valve connector.
- 6 Repeat steps 2 through 5 for any additional ink cartridges you need to replace.

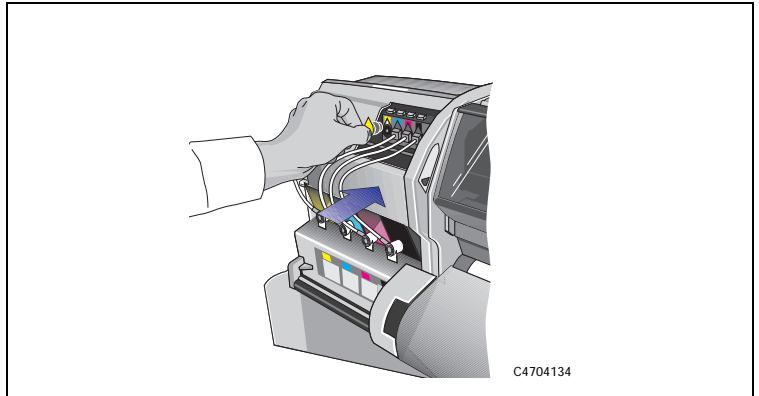

When you have finished replacing ink cartridges, the printer front panel displays the message “*Close left door to continue*”.

- 7 Close the left door on the printer.

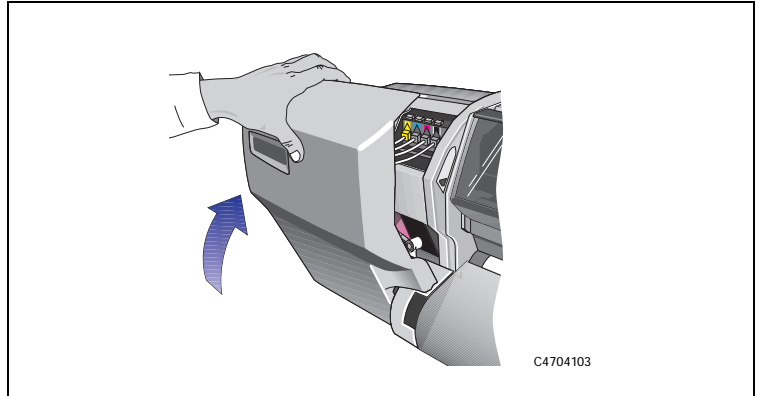

After the left door is closed, The front panel displays the message “*STATUS, Checking ink system*” while the printer checks that all ink system components have been installed correctly. This may take a few minutes.

Components Installed Correctly If all components have been installed correctly, the front panel displays “*Install complete*”.

Components Installed Incorrectly If any components have been installed incorrectly, the front panel will prompt you to take action to correct the problem. See *Front-Panel Messages*, for information about any messages that are displayed in the front panel.

Replacing the Ink System

After you replace the ink system, the printer performs some checks and alignments. If no media is loaded, the printer will display the message “*Load media to align printheads.*” Load media following the directions on page 33, *Installing a New Roll into the Printer.*, or page 39, *Loading sheet media.* The alignment procedure requires a minimum media size of A3 or B-size.

When the front panel displays “*STATUS Ready*”, you are ready to print.

NOTE

Make sure the printer window and the left and right doors are closed after you replace ink system components. The printer will not print while any doors are open.

Removing and Storing Partially Used Ink Systems

If you need to print several images unattended (for example, when printing overnight) and one or more of the ink colors is low on ink, you may want to replace these colors with new ones before starting to print and store them in the HP DesignJet CP Ink System Storage Container.

If you need to change from the HP DesignJet CP Ink System (*Imaging ink*) to the HP DesignJet CP Ink System UV (*UV Pigmented ink*) or vice versa, you will need to store the printheads and printhead cleaners that you are not using. When storing Ink Systems remember:

CAUTION

Do not touch the printhead nozzles.

Handle the Ink Systems with Care

- Always store the partially used printheads and printhead cleaners in the HP DesignJet CP Ink System Storage Container. Keep the partially used ink cartridges close by the HP DesignJet CP Ink System Storage Container. This will prevent unintentional mixing of different sets of ink system components.
- You can store the HP DesignJet CP Ink System UV (*UV Pigmented ink*) printheads and printhead cleaners in the storage container for up to six weeks without affecting the Outdoor Durability Warranty (providing you comply with the warranty procedures).
- Make sure all four ink colors that you are storing are the same type of HP Ink System. **Never mix UV Pigmented ink and Imaging ink components.**
- Always handle and store the printhead cleaners upright to avoid spilling ink.
- Handle the system with care.

Solving Ink System Problems

Important

An “ink system” refers to one color. It is made up of the ink cartridge, the printhead and the printhead cleaner.

All three components of an ink system must be used together. The three components are designed to be used together

Missing Ink System



MISSING INK SYSTEM
Install ----->

C4704034

When you first install your printer, or after removing ink systems and then powering on your printer, you will see this message. Press the ↓ key to install the missing ink systems. You will be prompted to install the printheads, printhead cleaners and ink cartridges in turn.

Ink System Error



INK SYSTEM ERROR
xxxxxx

C4704034

This message occurs after an earlier report of an error, when you have not fixed the problem. The error code “xxxxxx” indicates the nature of the problem. You will need to press the Replace Ink System key, to gain access to the printheads, printhead cleaners and ink cartridges. See the description of this message on page 89.

If the *Replace Ink System* Key does not Work

- 1 Make sure the window is closed before you press the **Replace Ink System** key.
- 2 Try pressing **Enter** to clear the previous message.
- 3 The printer may be busy; wait until it has completed the current process. Press the **Cancel** key if you want to interrupt the current process.

If Brand New Printheads have Problems

- 1 Your printer may not detect the ink system that you have installed. Make sure that the protective blue tape and green cardboard have been removed from the printheads.
- 2 Make sure that the electrical contacts on the printheads and the printer carriage are free from ink deposits. (See 76, *Cleaning Electrical Contacts*).
- 3 Try reseating the printheads. If you have trouble reseating the printheads, see *If You Have Problems Reseating a Printhead* on page 74.

NOTE: After you remove or reseat a printhead, the printer will run its automatic printhead alignment procedure.

- 4 Check the ink cartridge to see if it has ink.

If there is a Failure after Refilling Printheads

If you see the message “Ink cartridge valve out” or “Ink cartridges removed” after printheads have been refilled, it is because an ink cartridge valve has become disconnected or the printer cannot detect an ink cartridge. Printing is disabled.

To fix this problem:

- 1 Press the ↓ key.
- 2 When prompted, open the left door to access the ink cartridges.

You will see the message “Check ink cartridges / Abort” where the flashing squares indicate which valves to check. See 72, *Checking the Ink Cartridges*.

If you don’t correct the error now, you will see the status message “Ink system error”.

Printhead Alignment Errors

Printhead alignment
error ■ ■ □ ■ --->

C4704034

The printer runs the printhead alignment procedure every time you load, replace or even reseal a printhead. The routine is also run when media is loaded that is of a different media type from that previously loaded, or after powering on the printer with no media loaded.

The message “Printhead alignment error” is displayed when the alignment procedure has failed or the printer detects a fault that stops the procedure from completing. The alignment procedure is the first time that printheads print after installation, so an initial printing problem may be reported as an alignment error. Most alignment errors are due to:

- Problems with the media.
- Poor printhead start-up.
- Alignment difficulties with the printheads or other printhead malfunction.

You will see the message “Check ink system / Ignore” (see page 74, *If You Have Problems Reseating a Printhead*). If you choose to check the ink systems you will be given the opportunity to check the printheads that may have caused the problem.

Media Problems

- 1 Check that the media you are using is clean and has not been printed on. It should be white and opaque. Colored or clear films, media with insufficient opacity, or extremely thick or thin media may be causing the Printhead Alignment Error message.

- 2 Try performing the alignment procedure again (with **Image Quality / Printhead Service / Align Now**) using genuine HP media, or if this is not available, an opaque white media. If the printer now aligns correctly, the problem is probably the media type. (See also 65, *Working with Media that cannot be Used for Alignments* below.)
- 3 If the Printhead Alignment Error message still occurs, try recovering the printheads using **Utilities / Service Tests / Recover Printheads**. Then perform the alignment procedure again, using **Image Quality / Printhead Service / Align Now**.

Working with Media that cannot be Used for Alignments

You can still use media that the printer cannot align on. You will need to use a different type of media to realign the printheads whenever they are removed or reseated.

- 1 Unload the media that is causing problems.
- 2 Load media of a suitable type for calibrating. Make sure you do not change the **Media Type** selection.
- 3 Perform the alignment procedure again (with **Image Quality / Printhead Service / Align Now**).
- 4 Unload the media you used for alignment.
- 5 Reload the media that you want to use for printing, without changing the **Media Type** setting, as that would cause another alignment attempt on the unsuitable media.

Solving Ink System Problems

If your media is colored or not sufficiently opaque, we recommend disabling the Color Calibration (**Image Quality / Color Calib. / Off**) and Printhead Check (**Image Quality / Printhead Service / Check / Off**) features of your printer, as they may not work correctly.

Poor Printhead Start-Up

- 1 Perform the Recover Printhead procedure. Select **Utilities / Service Tests / Recover Printheads**.
- 2 Perform the alignment procedure again. Select **Image Quality / Printhead Service / Align Now**.

Other Symptoms or If the Problem is not Fixed Above

If the Printhead Alignment Error message still occurs, the printer will not be able to print with optimum quality.

- 1 In some cases you may be able to print, but image quality cannot be assured. It may be necessary to reseal or replace your ink system to restore normal performance.
- 2 If the printer will no longer print or you suspect printhead problems, see 74, *If You Have Problems Reseating a Printhead*.

Using the *Replace Ink System Key*

The **Replace Ink System** key can be used to check what is wrong with the ink system. If you think you know which part of the ink system is giving trouble (see 62, *If the Replace Ink System Key does not Work* and the list of messages on page 80, *Message Explanations and Actions*), focus on that section, but if you are not sure, try all the steps carefully.

The **Replace Ink System** key lets you access all components of the ink system, even if there is no reported error in any component. (When you start replacing components following a prompt from the front panel, the printer only gives you access to those components for which an error has been detected.)

Use the checklists on page 74, *If You Have Problems Reseating a Printhead*.

Checking Ink Systems

Check ink system ->
Ignore ----->

C4704034

If you see the message “Check ink system / Ignore” you can either proceed with the steps detailed in this section (press the ↑ key) or you can choose to continue printing (press the ↓ key).

If you select “Check ink system” (↑), you will only be asked to check those components for which the printer has detected an error.

If you select “Ignore” (↓), you can continue printing, but the quality of the images produced by the printer may be impaired.

NOTE: If an ink system replacement was cancelled, or the printer lost power during a replacement procedure, the machine may indicate that all four ink systems need to be replaced. Removal and reseating the components of each ink system may be all that is required. See *If You Have Problems Reseating a Printhead* 74.

You should only replace the ink systems for which errors are shown on the front panel. If more than one ink system shows an error, follow this procedure for each failing system. Do not remove and reseal printheads too many times, as this can lead to excessive wear on the electrical contacts, causing failures.

If problems persist, see *Persistent Ink-System Problems* 73.

CAUTION

If the problem occurred while changing ink system types (from Imaging to UV Pigmented, or vice versa), be extra careful to verify that all ink cartridges match the printheads in type. Installing the incorrect ink cartridge type can result in contamination of both of the ink systems.

- Press the ↑ key for “Check ink system”, if that message is present on the front panel.

Open the window when indicated.

Checking the Printheads

Check printhead

■ ■ □ ■ Abort ->

C4704034

Check the printhead if there is a printhead error reported.

The message “Check printhead / Abort” is displayed. The flashing squares indicate which printheads require checking. If you are unable to fix the errors now, press ↓ to cancel (abort) the procedure.

- Remove the printhead completely from the printer carriage. You should ensure that all four printheads are of the same type—Imaging (part numbers C1806A to C1809A) or UV Pigmented (C1892A to C1895A).

CAUTION

Do not touch, wipe, or attempt to clean the printhead nozzles. This can damage the printhead. Handle the ink systems with care. (See the diagram on page 77.)

- Make sure that the protective blue tape and green cardboard have been

Solving Ink System Problems

removed from the printhead.

- Next, look at the electrical contacts on the side of the printhead and on the carriage. If they are dirty, they should be cleaned (see page 76, *Cleaning Electrical Contacts*).
- Reinsert the printhead. In some cases, if you repeatedly get an error, with the squares continuing to flash, you may need to remove and reinstall all printheads to clear it. See *If You Have Problems Reseating a Printhead* on page 74.

Repeat these steps for any other printheads that need replacing.

Close the window.

Checking the Printhead Cleaners

Check ■ ■ * ■
Close right door

C4704034

If prompted, open the right door to access the printhead cleaners.

The message “Check / Close right door” is displayed. The stars in the message indicate which printhead cleaners must be checked.

- For each printhead cleaner, make sure that it is not overflowing (liquid all the way to the top of the large rectangular hole).
- Check that the part number on the printhead cleaner matches the type of ink system you are using. (The printhead, cleaner and ink cartridge must all be of the same type.) For Imaging Ink Systems the part numbers are C1806A to C1809A, and for UV Pigmented Ink Systems they are C1892A to C1895A.
- Check that the black and white label next to the large rectangular hole has not

been completely obscured by ink spray (some spray is normal). If it is, the printer may not be able to detect the printhead cleaner and will report a Head Cleaner Removed message. You will need to replace the entire ink system (printhead, printhead cleaner and the ink cartridge) if this is the case.

- Reinsert the printhead cleaner. Make sure it snaps into place properly.

Repeat these steps for any other printhead cleaners that need replacing.

Close the right door.

Checking the Ink Cartridges

Check ink cartridges

■ ■ □ ■ Abort -->

C4704034

If prompted, open the left door to access the ink cartridges.

The message “Check ink cartridge / Abort” is displayed. The flashing squares indicate which printheads require checking. If you are unable to fix the errors now, press ↓ to cancel (abort) the procedure.

- Check if any of the valves are loose in their holders. If so, this was probably the cause of the problem. Reinsert the valve, and pull on the valve handle gently to make sure it is seated properly. If you have recurring problems with a loose valve, it is probably occurring while the printheads are refilling. You will need to replace the ink system affected.
- If a loose valve was not the problem, remove the ink cartridges that show an error. Check if they are empty by shaking them gently. If it feels as though nothing is moving inside, the ink cartridge is empty and you will need to purchase a new ink system.
- Check that the triangular tab on the ink cartridge valve is not bent or broken. If you are getting an Ink Cartridge Removed message, this may be the cause. If any are bent or broken, you will need to replace your ink system.
- Check that the tubes coming from the ink cartridges are not bent or damaged. If they are, replace the ink system.
- Check that the part number on the ink cartridges matches the type of ink system you are using. (The printhead, cleaner and ink cartridge must all be of the same type.) For Imaging Ink Systems the part numbers are C1806A to C1809A, and for UV Pigmented Ink Systems they are C1892A to C1895A.

- Replace the ink cartridge valves in their correct color-coded locations. The triangular tabs on the valves must be pointing up for the printer to recognize them properly.

Close the left door.

Persistent Ink-System Problems

If this does not fix the problem:

- If the problem is still present, but not severe enough to prevent printing, the printer's front panel will indicate that the printer's image print quality cannot be assured, but you will be allowed to continue printing if you so desire.
- If the problem is serious enough to prevent printing from occurring, please call HP to help resolve the problem. Please have the messages your printer displayed available for the service representative to help speed the diagnosis process.

If You Have Problems Reseating a Printhead

Replace printhead



C4704034

Check printhead



C4704034

When printheads are installed, in extreme circumstances it is possible that the printer will not recognise them. This will be visible on the front panel with the message “Replace printhead ” or “Check printhead / Abort” where one or more of the squares are flashing. Each square represents a printhead, with the flashing ones representing printheads where the printer has detected a problem.

When you reseat or replace a printhead, the flashing filled square changes, for one or two seconds, to an hour-glass. At this point, the printer is testing the printhead. Don’t remove or insert another printhead while this test is being done.

- If the test is successful, the hour-glass reverts to its normal nonflashing filled state.
- If the test fails, the hour-glass will change back to a flashing filled square. To correct this, make the following checks:

- 1 Remove all four printheads completely from the printer. On the front panel the displayed message will change to show four flashing lights.
- 2 Look at the electrical contacts on the printhead and carriage. If they are dirty, they should be cleaned (see page 76, *Cleaning Electrical Contacts* on page).
- 3 Reinstall each printhead, one at a time; if the flashing squares stop flashing, then the printheads have passed the test. **DO NOT INSERT THE NEXT**

PRINthead UNTIL THE PRINTER HAS ACCEPTED THE CURRENT ONE.

If the lights continue flashing and the printheads have been inserted correctly, try reseating them a few more times, by removing the printhead from its stall and then replacing it until it snaps correctly into position.

NOTE: Do not leave printheads partly inserted in the carriage; they may be making electrical contact and be the cause of the reseating problem, as you try to reseat other printheads.

If the printer still refuses to accept your printheads, try replacing the indicated ink system (see 74, *If You Have Problems Reseating a Printhead*) or call HP for assistance.

Cleaning Electrical Contacts

The printer prints by firing tiny drops of ink onto the media. This is controlled by electrical signals that are sent from the printhead carriage to the printhead through electrical contacts. During normal printing operations, it is possible for ink to get spilt onto these electrical contacts. Ink can also be spilt onto them when printheads are loaded into the carriage.

To clean the electrical contacts, you will need some cotton swabs, lint-free cloths, soft tissues or napkins. You will also need some clean water, preferably distilled. Avoid using dry cotton swabs, as lint from the cotton may leave debris or other contaminants; avoid also using dry cloths, as they may scratch delicate surfaces.

Alternatively, you can use a suitable cleaning kit, for example, the HP C6247 Ink Cleaner—follow the supplied instructions.

- 1 Prepare a clean cotton swab by dampening it with distilled water. Rotate the end of the swab between your fingers to pack the cotton and to remove excess water.

If you are using a cloth or tissue, make it slightly damp, but not so wet that it drips or disintegrates.

If you need to clean more than one ink system, use fresh swabs for each one, to

avoid cross-contamination.

Do not power off the printer.

CAUTION

Never drip water into the printer.

- 2 To clean the electrical contacts on the printhead, remove it from its stall and, holding it by the cap, turn it as shown below.

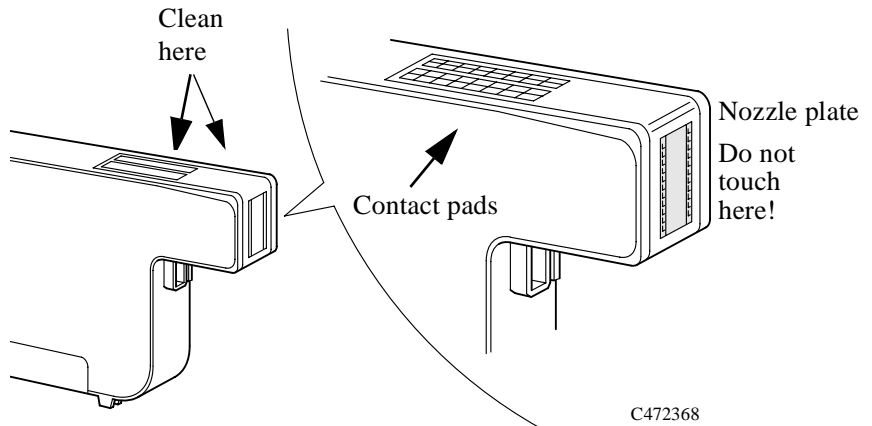

Solving Ink System Problems

CAUTION

Do not touch, wipe, or attempt to clean the printhead nozzles (on the right-hand side in the diagram above). This can damage the printhead. Handle the ink systems with care.

- Using damp cotton swabs, clean the electrical contact pads (the copper strip), especially where it bends down towards the nozzle plate. Wipe the contact pads very gently towards the cap end of the printhead, away from the nozzle plate. If you are using a cloth or tissue, use gentle pressure to avoid damaging the contacts. If you are using the cleaning kit, wipe the printhead cleaner pads as shown below:

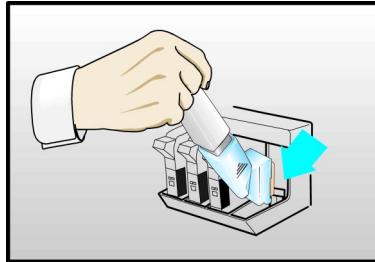

C472380

Solving Ink System Problems

- 4** Using damp cotton swabs, clean the electrical contact pads on the printhead carriage (indicated by the arrow in the diagram).

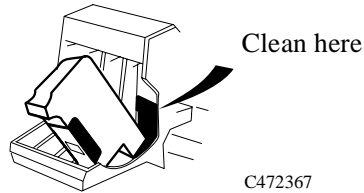

If you are using the cleaning kit, wipe the printhead as shown below:

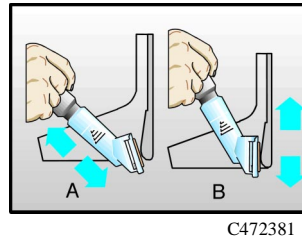

- 5** Wait until all the cleaned parts are dry and then reinstall the printhead

Message Explanations and Actions

This is a list of the messages in the front-panel display. If an action is needed, it is shown in italics in the Explanation and Action column. The messages are listed in alphabetical order.

Message	Explanation and Action
Accessing head cleaners	The printer is moving the platform that contains the printhead cleaners to a place where you can access them. <i>Wait for a few seconds until this operation has finished.</i>
Accessing printheads	The printer is moving the carriage that contains the printheads to a place where you can access them. <i>Wait for a few seconds until this operation has finished.</i>
Action unavailable Entry being printed	A print is being printed and you have requested to move, delete or modify the number of copies through the queue management menu. You cannot change the current entry until the print has finished. <i>Wait until the print has finished.</i>
Back media→ Forward media→	You are loading the Take Up Reel, to move the leading edge of the media down to the Take Up Reel press the ↓ key. If you need to move the media back up because you have gone too far down press the ↑ key.

Message	Explanation and Action
Calibrate error Continue→	The calibration print was loaded incorrectly and it could not be measured. <i>Press ↓ to continue, then reload the print for measurement. Follow front panel instructions.</i>
Calibrate Yes → Color No →	You are using sheet media and color calibration is on. The printer is asking you if you want to calibrate the color for the loaded media. <i>Press ↑ for yes. Press ↓ for no.</i>
Calibration done Continue→	Accuracy calibration is complete. <i>Press ↓ to continue.</i>
Cancelled Continue→	You have just cancelled the last print or function. <i>Press ↓ to continue.</i>
Check ■■■*■ Close right door	The printer has detected an error in the printhead cleaners indicated by the stars. <i>Reseat (do not replace) the indicated cleaners. When you have done so, close the right door of the printer. See 70, Checking the Printhead Cleaners.</i>
Check ink cartridges ■■■□■ Abort →	The printer has detected an error in the cartridges indicated by the empty squares. <i>Reseat (do not replace) the indicated cartridges or press the ↓ key to terminate the procedure. In this case, you will not be able to print, and you may later resume checking the ink system by pressing the Replace Ink System button. See 72, Checking the Ink Cartridges.</i>

Message Explanations and Actions

Message	Explanation and Action
Check ink system→ Ignore→	<p>After an error has been detected in the ink system, you are given the chance to check it.</p> <p><i>Press ↑ to check the ink system right now. The printer will indicate which ink systems are affected.</i></p> <p><i>Press ↓ to ignore the error and continue printing. In this case the image quality cannot be assured.</i></p> <p><i>To fix any errors, see the check-lists in 68, Checking Ink Systems.</i></p>
Check printheads ■■■□■ Abort →	<p>The printer has detected an error in the printheads indicated by the empty squares. The printhead can be replaced, but you should replace all components of the failing ink systems as soon as possible.</p> <p><i>Reseat (do not replace) the indicated printheads or press the ↓ key to terminate the procedure. In this case, you will not be able to print, and you may later resume checking the ink system by pressing the Replace Ink System button. (If you have persistent problems, see If You Have Problems Reseating a Printhead 74.)</i></p>
Close left door to continue	<p>You opened the left door while the printer was busy, or you have finished installing the ink cartridges.</p> <p><i>Close the left door to continue.</i></p>
Close roll cover Continue→	<p><i>Rewind the media to take up any slack in the roll, close the roll cover, then press ↓ to continue.</i></p>

Message	Explanation and Action
Close window to continue	<p>You have finished installing the printheads.</p> <p><i>Close the window to continue.</i></p>
Create pattern→ Measure pattern→	<p><i>Press ↑ to create the pattern for automatic calibration.</i></p> <p><i>Press ↓ to measure the pattern for automatic calibration.</i></p>
Edge not found Reload media	<p>The printer could not find edge of media during loading procedure.</p> <p><i>Check the leading edge of the media for unevenness or tears; cut a straight edge, if necessary, and reload. Be sure to position the right edge along the perforated line on the entry platen when loading.</i></p>
Error processing job Flushing rest of job→	<p>An error was encountered while the print was being processed. The print has been lost.</p> <p><i>Press ↓ to delete the print.</i></p>

Message Explanations and Actions

Message	Explanation and Action
Head cleaner full ■■■□■→	<p>Either: After finishing printing, the printer has detected that one or more of the printhead cleaners are full of ink. The squares that are flashing indicate the head cleaners that are full.</p> <p><i>Press ↓ to continue. The message “Check ink system→ / Ignore→” is displayed. If you press ↓ again to continue, you may still be able to print again, but the ink in the head cleaner may overflow and the print quality of your images may be affected. To fix the problem, select ↑ to check the ink system; see 68, Checking Ink Systems.</i></p> <p>Or: In the ink system replacement process, one or more of the printhead cleaners have not been replaced at the same time as the corresponding printheads. The squares that are flashing indicate the head cleaners that are full.</p> <p><i>Press ↓ to continue. You may still be able to print again, but image print quality may be affected, as indicated by a subsequent message. See 68, Checking Ink Systems.</i></p>
Head cleaner ink may overflow→	<p>One or more of the printhead cleaners are full of ink, and the ink may overflow.</p> <p><i>Press ↓ to continue. Image print quality may be affected, and ink may leak inside the printer and damage it. Replacement of the ink systems affected is recommended. To fix problems with the ink system, see 68, Checking Ink Systems.</i></p>

Message	Explanation and Action
Head cleaner removed ■■□■→	<p>The printer has detected that one or more printhead cleaners have become dislodged or the printer cannot detect them, as indicated by the flashing squares. Printing is disabled.</p> <p><i>Press ↓ to check the failing head cleaner. You should reseat the head cleaners immediately; see 70, Checking the Printhead Cleaners. If this does not solve the problem, you will have to replace the entire ink system (printhead, printhead cleaner, and ink cartridge) using the Replace Ink System key.</i></p> <p><i>If you don't correct the error now, you will see the status message "Ink system error" described on page 89.</i></p>
Image quality not assured→	<p>This message appears after the printer finds an error in the ink system. One or more of the ink systems have passed their specified life, one or more of the printhead cleaners are full of ink, or one or more of the printheads has failed an electrical test, or an alignment or nozzle check.</p> <p><i>Press ↓ to continue. You may continue printing, but you may not get your usual image print quality. To fix problems, see 68, Checking Ink Systems.</i></p>
Imaging inks YES→ installed NO→	<p>After you have finished installing a new ink cartridge, you are asked to confirm that you have changed the type of ink cartridges from UV Pigmented to Imaging.</p> <p><i>Press ↑ to confirm that you have changed the ink cartridges from UV Pigmented to Imaging.</i></p> <p><i>Press ↓ to indicate that you have not changed the ink cartridges from UV Pigmented to Imaging. You will then be given the opportunity of replacing the incorrect ink cartridges by the correct ones.</i></p>

Message Explanations and Actions

Message	Explanation and Action
Incorrect ink system ■■■□■→	<p>After you used the Replace Ink System procedure, which was cancelled by a time-out or aborted (see Checking Ink Systems 68), the printer has detected that one or more of the ink systems are still faulty or have not been fully replaced, as indicated by the flashing squares. This message also appears if the printer believes that a component is incorrect; you must then confirm that the ink system is indeed correct, or rectify the error.</p> <p><i>Press ↓ to continue, to replace the ink systems. Printing will be disabled. You should replace the faulty ink systems immediately; see page 68, Checking Ink Systems.</i></p> <p><i>If you don't correct the error now, you will see the status message "Ink system error" described on page 89.</i></p>
Initializing new ink system	<p>In the ink system replacement process, you have swapped an Imaging ink system for a UV Pigmented ink system, or vice versa. The printer will reinitialize and prepare to print with the new ink system.</p> <p><i>Wait until the new ink system has been initialized.</i></p>

Message	Explanation and Action
Ink cartridge removed ■■□■→	<p>The printer has detected that one or more ink cartridges have been removed or cannot be detected, as indicated by the flashing squares.</p> <p><i>Press ↓ to check the failing ink cartridge. Printing has been disabled. You should reseal the ink cartridge immediately; see 72, Checking the Ink Cartridges. If this does not solve the problem, you will have to replace the entire ink system (printhead, printhead cleaner, and ink cartridge) using the Replace Ink System key.</i></p> <p><i>If you don't correct the error now, you will see the status message "Ink system error" described on page 89.</i></p>
Ink cartridge valve out ■■□■→	<p>The printer has detected that one or more of the ink cartridge valves (as indicated by flashing squares) has popped out during refilling.</p> <p><i>Press ↓ to check the failing ink cartridge. You should reseal the valves immediately; see 72, Checking the Ink Cartridges. If this does not solve the problem, you will have to replace the entire ink system (printhead, printhead cleaner, and ink cartridge) using the Replace Ink System key.</i></p>

Message Explanations and Actions

Message	Explanation and Action
Ink system at end of life ■■■□→	<p>The printer has found that an earlier “Out of ink” error has not been corrected. One or more components of the ink system, as indicated by flashing squares, have reached the end of their intended lives. You should now replace all three components of those ink systems affected (the printheads, the printhead cleaners and the ink cartridges). See the general comments about ink systems on page 68.</p> <p><i>Press ↓ to continue. Image print quality may be affected. Replacement of the ink systems affected is recommended. To fix problems with the ink system, see 68, Checking Ink Systems.</i></p>
Ink system at end of life. Retry→	<p>The printer has detected that one or more components of the ink system have reached the end of their intended lives. You should now replace all three components of those ink systems affected (the printheads, the printhead cleaners and the ink cartridges). See the general comments about ink systems on page 68.</p> <p><i>Press ↓ to replace the erroneous ink systems. See 68, Checking Ink Systems.</i></p>

Message	Explanation and Action
Ink System Error xx-xxxx	<p>The printer has detected an error in the ink system, as shown in earlier messages. Printing will be disabled until the error has been corrected. If more than one error is pending, the one with the highest number, corresponding to the most severe error, will be displayed.</p> <p>Possible error codes (xxxxxx) are:</p> <ul style="list-style-type: none"> • 58.... See the message “Incorrect ink system” • 65.... or 66.... See the message “Printhead failure” • 67.... See the message “Printhead contact error” • 72.... See the message “Ink cartridge removed” • 73.... See the message “Head cleaner removed” • 74.... See the message “Printhead removed” • 88.... See the message “Mixed ink system”. <p><i>Press the Replace Ink System key to replace the erroneous ink systems in order to print with your printer again. See 68, Checking Ink Systems.</i></p> <p><i>Press the Enter key to access the main front panel menus.</i></p>
Install complete	<p>Ink system replacement has been completed successfully.</p> <p><i>Resume normal operations.</i></p>
Lift lever after aligning	<p>You have lowered the media lever to align the media with the entry platen.</p> <p><i>Lift the lever at the right edge of the paper path on the printer when you’ve finished aligning the roll media as instructed.</i></p>
Lift lever to continue	<p>The media lever was lowered while the processor was busy.</p> <p><i>Lift the lever at the right edge of the paper path on the printer.</i></p>

Message Explanations and Actions

Message	Explanation and Action
Load arrow edge print side down	<i>Remove the accuracy calibration print, turn it so that the edge with the arrows printed on it is print-side down, then load that edge into the printer.</i>
Load cancelled Remove media	The Cancel key was pressed while media loading was in progress. <i>Remove media.</i>
Load error Remove media	Media was inserted with the media lever raised. <i>Lower the lever and reload the media.</i>
Load media for calibration	<i>Load media to proceed with calibration.</i>
Load media to align printheads	<i>Load media to proceed with printhead alignment.</i>
Load media to check printheads	The printer is telling you to load media so it can perform the printhead check. <i>Load media to proceed with printhead check.</i>
Load sheet for calibration	The printer is ready to perform the accuracy calibration procedure, but media is not present. <i>Load media to continue.</i>
Lower lever	<i>Lower the lever at the right of the printer.</i>
Lower lever Remove media	<i>Lower the lever at the right of the printer and remove the media.</i>
Lower window to continue	The window was opened while the printer was busy. <i>Close the window to continue.</i>

Message	Explanation and Action
Media too small	<p>You may have sent a print file that is too large for the media loaded; the print may be clipped.</p> <p><i>Press Cancel if the media is unsuitable, and reload with appropriate media.</i></p>
Media too small for calibration→	<p>The media you loaded for printhead alignment or a printhead check is too small. The procedure has been cancelled. You may continue printing without calibrating the printer, but the image quality is not assured.</p> <p><i>Press ↓ to continue. If you want to complete the interrupted procedure, reload with appropriate media (A3-size paper or larger, in landscape orientation) and redo the procedure:</i></p> <ul style="list-style-type: none"> • Use Image quality / Printhead service / Align now for printhead alignment. • Use Image quality / Printhead service / Printheads check / Now for a printhead check.
MIO error Communication break	<p>The flow of data from the computer to the printer stopped prematurely (for example, the computer may have been shut down before all data was sent).</p> <p><i>Press Enter to clear the message from the front panel display.</i></p>
MIO error handshake	<p>You configured the modular interface incorrectly.</p> <p><i>Press the Enter key to clear the message from the front panel. Check the handshake settings in the printer's front panel, in the hardware configuration, and in your application software configuration to make sure they are compatible with one another.</i></p>

Message Explanations and Actions

Message	Explanation and Action
Mispositioned Reload roll	The roll media is mispositioned. <i>Remove and reload the roll.</i>
Mispositioned Reload sheet	The sheet media is mispositioned. <i>Remove and reload the sheet.</i>
MISSING INK SYSTEM Install→	One or more ink systems are missing. <i>Press ↓ or the Replace Ink System key to install the ink systems in order to print with your printer.</i>
Mixed ink system □■ ■■ →	At power-on or after the ink systems have been serviced, the printer has detected components of different ink system types (for example, Imaging and UV Pigmented). Printing will be disabled until the ink systems are all of the same type. The flashing squares indicate which ink systems need checking. The error may be because the printhead, printhead cleaner and ink cartridge within an ink system are not all of the same type (UV Pigmented or Imaging) or that entire ink systems are of different types. <i>Press ↓ to continue, to check the ink systems. See 68, Checking Ink Systems.</i>

Message	Explanation and Action
MIXED INK SYSTEM 88xxxx	<p>The printer has earlier detected components of different ink system types (for example, Imaging and UV Pigmented). Printing will be disabled until the ink systems are all of the same type. The error code “88xxxx” indicates a mixed ink system error.</p> <p><i>Press the Replace Ink System key to replace the erroneous ink systems in order to print with your printer again. You can press the Enter key to access the main front-panel menu.</i></p> <p><i>See 68, Checking Ink Systems.</i></p>
Open left door to access ink cartrg.	<p>You are doing an ink system replacement.</p> <p><i>Open the left door to access the ink cartridges.</i></p>
Open right door to access head cleaners	<p>You are doing an ink system replacement.</p> <p><i>Open the right door to access the printhead cleaners.</i></p>
Open window to access printheads	<p>You are doing an ink system replacement.</p> <p><i>Open the window to access the printheads.</i></p>
Out of Ink ■■■■□ →	<p>The printer has detected that the amount of ink in the ink systems indicated by one or more flashing squares, is below acceptable limits for satisfactory printing.</p> <p><i>Press ↓ to check the indicated ink systems. See 68, Checking Ink Systems. You will be prompted to change the kit or to ignore the error and continue printing. If there is still a large amount of ink remaining in the ink cartridges, see the message Printhead failure on page 98.</i></p>

Message Explanations and Actions

Message	Explanation and Action
Out of memory Data was lost	<p>The current file is too large for the printer's memory; the printer has run out of disk space for processing the file.</p> <p><i>To print files of this size, you may need to install more memory to your printer.</i></p>
Press ENTER when done	<p>The printer is waiting for you to confirm an action or selection.</p> <p><i>When you have taken the appropriate action press the Enter key.</i></p>
Press Load Button to continue	<p>You are loading media into the printer and the Media Button has been activated by your actions. <i>Press the Media Button and the media will be fed into the printer.</i></p>
Printhead alignment cancelled→	<p>The printhead alignment procedure has failed, or the printer has detected a fault that stops the procedure from completing. Subsequent messages will explain the error further:</p> <ul style="list-style-type: none">■ “Replacement of lens cover recommended”—<i>You should check the section on replacing lens covers on page 10-3, Lens Maintenance in the Users' Guide.</i>■ “Media too small for calibration”—<i>The roll that is loaded is not wide enough for the calibration to be done. It must be at least A3 size. You should load appropriate media and repeat the procedure again, using Image Quality / Printhead Service / Align Now. If you use sheet media that is too small, the printer will reject the media and prompt you to load new media.</i> <p><i>Press ↓ to continue. You may continue printing, but you may not get your usual image print quality. To fix problems with the ink system, see 68, Checking Ink Systems.</i></p>

Message	Explanation and Action
Printhead alignment error ■■□■→ <i>or</i> Printhead alignment error →	<p>The printhead alignment procedure has failed, or the printer has detected a fault that stops the procedure from completing. The squares that are flashing indicate the ink systems that have failed. If the message contains no squares, the procedure has failed because of a problem that is not related to specific printheads, for example, a problem with the media.</p> <p><i>Press ↓ to continue. The message “Check ink system→ / Ignore→” should be displayed. If you press ↓ again to continue, you may still be able to print again, but image print quality may be affected. To fix the problem, select ↑ to check the ink system; see 64, Printhead Alignment Errors.</i></p>
Printhead check cancelled→	<p>The printhead check procedure has failed, or the printer has detected a fault that stops the procedure from completing. Subsequent messages will explain the error further:</p> <ul style="list-style-type: none"> ■ “Replacement of lens cover recommended”—<i>You should check the section on replacing lens covers on page 10-3, Lens Maintenance in the Users’ Guide.</i> ■ “Media too small for calibration”—<i>The roll that is loaded is not wide enough for the check to be done. It must be at least A3 size. You should load appropriate media and repeat the check again, using Image Quality / Printhead Service / Printheads Check / Now. If you use sheet media that is too small, the printer will reject the media and prompt you to load new media.</i> <p><i>Press ↓ to continue. You may continue printing, but you may not get your usual image print quality. To fix problems with the ink system, see 68, Checking Ink Systems.</i></p>

Message Explanations and Actions

Message	Explanation and Action
Printhead check error ■■■□■→ or Printhead check error →	<p>The message “Printhead check error” may be displayed if:</p> <ul style="list-style-type: none">■ <i>You are using colored media. Either disable checking or use media that is clean, white, and opaque. See the remarks on 64, Media Problems.</i>■ <i>There are dirty nozzles on the printhead. Replace your ink system (see page 68, Checking Ink Systems). Do not attempt to clean the nozzles.</i> <p>The squares that are flashing indicate the ink systems that have failed. If the message contains no squares, the procedure has failed because of a problem that is not related to specific printheads, for example, a problem with the media.</p> <p><i>Press ↓ to continue. The message “Check ink system→ / Ignore→” will be displayed. If you press ↓ again to continue, you may still be able to print again, but image print quality may be affected. To fix the problem, select ↑ to check the ink system; see 68, Checking Ink Systems.</i></p>

Message	Explanation and Action
Printhead contact error ■■□■→	<p>The printheads, indicated by flashing squares, have failed to function because of an unusual electrical signal from the printhead. The most likely cause of this message is that the electrical contacts on the printhead or printer carriage are dirty and need cleaning.</p> <p><i>Press the ↓ key to check the printheads. Open the window when indicated, and remove the printheads indicated.</i></p> <p><i>Look at the electrical contacts on the printhead and carriage. If they are dirty, they should be cleaned (see 76, Cleaning Electrical Contacts).</i></p> <p>CAUTION: <i>Do not touch, wipe, or attempt to clean the printhead nozzles. This can damage the printhead. Handle the ink systems with care.</i></p> <p><i>If you don't correct the error now, you will see the status message "Ink system error" described on page 89.</i></p>

Message Explanations and Actions

Message	Explanation and Action
Printhead failure ■■■□■→	<p>The printheads indicated by flashing squares have failed, either during printhead initialization or during printing. The printer may have detected an unusual electrical or thermal signal from the printhead that may require attention. The most likely causes of this message are:</p> <ul style="list-style-type: none">■ The ink cartridge is empty. If this is so, your ink system has reached the end of its normal life, and you will need to buy a new ink system to replace the old one.■ There has been a problem inside the printhead that has caused it to fail, for example, the printhead has overheated. <p><i>You should replace the indicated ink systems immediately.</i></p> <p><i>Press the ↓ key to check the printheads. Open the window when indicated, and remove the printheads indicated. Try reseating the printhead (see page 74, <i>If You Have Problems Reseating a Printhead</i>). If the problem recurs, the ink system should be replaced at the earliest opportunity.</i></p> <p><i>If you don't correct the error now, you will see the status message "Ink system error" described on page 89.</i></p>
Printhead removed ■■■□■→	<p>The printer has detected that one or more printheads have become dislodged or the printer cannot detect them, as indicated by the flashing squares.</p> <p><i>Press ↓ to continue. You should reseat the printheads immediately or replace the ink system; see 69, <i>Checking the Printheads</i>.</i></p> <p><i>If you don't correct the error now, you will see the status message "Ink system error" described on page 89.</i></p>

Message	Explanation and Action
Printing disabled→	<p>The printer cannot print, because of errors previously notified.</p> <p><i>Press ↓ to continue. Then press the Replace Ink System key to replace the erroneous ink systems in order to print with your printer again. See 68, Checking Ink Systems.</i></p>
Pull ↓ Align ↔ edges to roll	<p>You are aligning roll media.</p> <p><i>Grasp the left and right free edges of the roll media and pull them towards you until the media is taut. At the same time, align the left and right edges of the media so that they are flush with the left and right edges of the roll.</i></p>
Reload media	<p>There was an error loading the media and the printer has ejected it. The printer is waiting for you to reload the media.</p> <p><i>Reload the media.</i></p>
Reload sheet	<p>Sheet media was loaded skewed and the printer ejected it.</p> <p><i>Reload the sheet.</i></p>
Remove all ink cartridge(s)	<p>You have selected the option Utilities / Transport mode of the front-panel menu, and opened the left door when instructed.</p> <p><i>The printer is instructing you to remove all the ink cartridges.</i></p>
Remove all printheads	<p>You have selected the option Utilities / Transport mode of the front-panel menu, and lifted the window when instructed.</p> <p><i>The printer is instructing you to remove all the printheads.</i></p>

Message Explanations and Actions

Message	Explanation and Action
Remove head cleaners Close right door	You have selected the option Utilities / Transport mode of the front-panel menu, and opened the right door when instructed. <i>The printer is instructing you to remove all the printhead cleaners, and then close the right door.</i>
Remove media	The ink is dry. <i>Remove the accuracy calibration print that has just been produced. Press ↓ to continue with accuracy calibration.</i>
Remove media Lift lever	An attempt to load media was made while the media lever was lowered. <i>Remove the media, lift the lever, and reload media with the lever up.</i>
Remove the Media Weight Continue→	You are removing media from the Take Up Reel. Before you are able to do this you have to remove the Media Weight (see Glossary) and chapter 3. <i>When you have removed the Media Weight press Continue→.</i>
Replace ink cartridge(s) ■■■■□	You are in the ink system replacement process, and opened the left door when instructed. <i>The printer is waiting for you to replace the ink cartridges indicated by flashing squares.</i>

Message	Explanation and Action
Replace lens cover Continue→	<p>You are in the ink system replacement process, and lifted the window when instructed.</p> <p><i>The printer is waiting for you to replace the lens cover on the printhead carriage with a new one. Spare lens covers are inside the right door. Press ↓ to continue when you have completed the lens replacement. See the instructions for lens cover replacement on page 10-3, Lens Maintenance in the Users' Guide.</i></p>
Replace mixed printhead(s) ■■●■	<p>One of the printheads inserted into the printer is of a different ink system to the others.</p> <p><i>Remove the incorrect printhead and replace with a printhead which is of the same type of ink system as the others.</i></p>
Replace printhead(s) ■■□■	<p>You are in the ink system replacement process, and lifted the window when instructed.</p> <p><i>The printer is waiting for you to replace the printheads indicated by flashing squares. (If you have persistent problems, see page 74, If You Have Problems Reseating a Printhead.)</i></p>
Replace printhead(s) Close window	<p>You are in the ink system replacement process, and lifted the window when instructed.</p> <p><i>The printer is waiting for you to replace a printhead, or you can close the window without making any changes. (If you have persistent problems, see page 74, If You Have Problems Reseating a Printhead.)</i></p>

Message Explanations and Actions

Message	Explanation and Action
Replace ■■■* Close right door	<p>You are in the ink system replacement process, and opened the right door when instructed.</p> <p><i>The printer is waiting for you to replace the printhead cleaners indicated by *s, and then close the right door.</i></p>
Replacement of ink system recommended→	<p>You are about to finish the ink system replacement process, and the printer recommends replacing one or more of the four ink systems (for example, because they have passed their specified life).</p> <p><i>Press the ↓ key to continue. You will see the status message “Low on ink”. Then press the Replace Ink System key to replace the ink systems that will be indicated.</i></p>
Replacement of lens cover recommended→	<p>The printhead alignment procedure, or the printhead check procedure, or a calibration check has failed because the lens cover is dirty and needs replacing. Printing may continue but the image quality is not assured.</p> <p><i>Press ↓ to continue. See the instructions on page 10-3, Lens Maintenance in the Users' Guide. Spare lens covers are inside the right door.</i></p>
Roll empty Load new roll	<p>You have used all of the media roll.</p> <p><i>Load a new roll of media.</i></p>
Roll misaligned Reload roll	<p>Roll media is skewed.</p> <p><i>Reload media.</i></p>

Message	Explanation and Action
Set transport→ Yes Mode→ No	You have selected transport mode in the front-panel menu. The printer is waiting for you to accept or reject the transport mode. Accepting transport mode starts the process of removing all ink systems. <i>Press ↑ to accept or press ↓ to reject.</i>
Sheet load→ Roll load→	<i>Press ↑ to load sheet media. Press ↓ to load roll media.</i>
Sheet misaligned Reload sheet	Sheet media is skewed. <i>Remove it and reload it so that the left and right edges being loaded into the printer are square. The leading edge must also be straight.</i>
Sheet required for calibration	You have started an accuracy calibration check but media is not present. <i>Load media.</i>
Sheet / Roll? Reload media	Either: Sheet mode was chosen while loading roll media. <i>Reload media.</i> Or: a sheet more than 51 inches (130 cm) long was loaded. <i>Trim the sheet and reload.</i>
STATUS messages	See pages 106 through 111.
Switch power off	You have selected the transport mode shut-down sequence. The printer is waiting for you to turn the power switch, on the rear of the printer, to off. <i>Switch off the printer.</i>

Message Explanations and Actions

Message	Explanation and Action
Switch power off Check paper path	The printer may be jammed with media. <i>Turn off the printer. Check the media path and clear it if necessary. Then turn on the printer.</i>
Switch power off Check printhead path	The printhead carriage cannot move. The printer may be jammed with media. <i>Turn off the printer. Check the media path and clear it if necessary. Then turn on the printer.</i>
System Error 060000	The ambient light level in the area of your printer is too bright and is causing the optical sensor in your printer to malfunction. <i>Reduce the ambient light level or move the printer to a location where the light level is lower.</i>
System error XXXXXX	An internal error has occurred and a system error number is displayed. <i>Press Enter; this may clear the error and allow you to continue. If you cannot continue, turn off the printer, and then turn it on again. If you still see the system error message, record the system error number and call HP to have the printer serviced.</i>
System error XXXXXX XXXXXXXX	An internal error has occurred and a system error number is displayed. <i>Press Enter; this may clear the error and allow you to continue. If you cannot continue, turn off the printer, and then turn it on again. If you still see the system error message, record the system error number and call HP to have the printer serviced.</i>

Message	Explanation and Action
trim edge→ continue→	The Take Up Reel is turned on and you are about to load the media onto it, you now have the option of trimming the edge or to continue. <i>You only need to trim the edge if the media was damaged in the loading process or is not straight, It is important when loading media onto the Take Up Reel that the media is taped onto the core tube straight.</i>
UV inks YES→ installed NO→	After you have finished installing a new ink cartridge, you are asked to confirm that you have changed the type of ink cartridges from Imaging to UV Pigmented. <i>Press ↑ to confirm that you have changed the ink cartridges from Imaging to UV Pigmented.</i> <i>Press ↓ to indicate that you have not changed the ink cartridges from Imaging to UV Pigmented. You will then be given the opportunity of replacing the incorrect ink cartridges by the correct ones.</i>
Verify ink system ■■□■→	At power-on, the printer has detected an error in the ink systems shown by flashing squares. <i>Press ↓ to continue. You should check the ink systems immediately; see 68, Checking Ink Systems.</i>
Wind the Take Up Reel Cut→	You are removing media from the Take Up Reel. Before you Cut the media to remove it, you must wind up the media onto the Take Up Reel or the media will fall to the floor and possible damage it. Press the wind button on the Take Up Reel and then press the ↓ key to cut the media.

STATUS Messages

Message	Explanation and Action
STATUS Accessing head cleaners	You have pressed the Replace Ink System key or there is an error in the head cleaners and you have pressed ↑ or ↓. The carriage is moving so that you can access the printhead cleaners. <i>Wait until the carriage is in position.</i>
STATUS Accessing printheads	You have pressed the Replace Ink System key or there is an error in the printheads and you have pressed ↑ or ↓. The carriage is moving out so that you can access the printheads. <i>Wait until the carriage is in position.</i>
STATUS Aligning printheads	The printer is printing a pattern to align the printheads. <i>Wait until the pattern has been printed.</i>
STATUS Calibrating	The printer is performing the accuracy calibration check. <i>Wait until the printer has finished the check.</i>
STATUS Calibrating color	(HP DesignJet 3500CP only) The printer is performing a color calibration. <i>Wait until the printer has finished calibrating.</i>
STATUS Calibrating printhds	The printer is performing an internal printhead calibration. <i>Wait until the printer has finished calibrating.</i>
STATUS Cancelling	The Cancel key has been pressed and the printer is in the process of cancelling a file or procedure. <i>Continue when this message is no longer displayed.</i>

Message	Explanation and Action
STATUS Check pending	<p>The right door has been opened while the printer was busy (for example, printing) and the printer is waiting to check the ink system. You may have done something that will affect image print quality.</p> <p><i>Do not open any door or window on the printer when not instructed and it is busy.</i></p>
STATUS Checking ink system	<p>The printer is verifying that the ink system was correctly installed, or that all the components are present after any door or window on the printer has been opened.</p> <p><i>Wait until the check is complete.</i></p>
STATUS Checking media	<p>The printer is checking to see if media is correctly positioned with respect to the perforated line of the entry platen.</p> <p><i>Wait until the check is complete.</i></p>
STATUS Checking printheads	<p>The printer is printing a pattern to test the printheads.</p> <p><i>Wait until the check is complete.</i></p>
STATUS Creating pattern	<p>The printer is performing an accuracy calibration.</p> <p><i>Wait until the calibration is complete.</i></p>
STATUS Head cleaner(s) full	<p>One or more of the printhead cleaners are full of ink. The printer will continue printing but image print quality may be affected, and ink may leak inside the printer and damage it.</p> <p><i>Press the Replace Ink System key to replace the ink systems affected. See 68, Checking Ink Systems.</i></p>

Message Explanations and Actions

Message	Explanation and Action
STATUS Initializing	The printer is doing an internal check on power-up. <i>Wait until the printer has finished initializing.</i>
STATUS Ink drying (xx m xx s)	The ink on your print is drying. <i>Wait before removing the print. If you remove it before the indicated time has passed, avoid smearing the ink.</i>
STATUS Lens maintenance	The lens cover on the printhead carriage requires maintenance. <i>Press the Replace Ink System key to replace the lens cover with a new one. Spare lens covers are inside the right door. See the instructions for lens cover replacement on page 10-3, Lens Maintenance in the Users' Guide.</i>
STATUS Loading roll	The printer is loading roll media. <i>Wait for the loading to complete.</i>
STATUS Loading sheet	The printer is loading sheet media. <i>Wait for the loading to complete.</i>
STATUS Low on ink	One or more of the four ink systems are out of ink. <i>Press the Replace Ink System key to replace the ink systems affected, if the last print showed any degradation in image print quality. If there is still a large amount of ink remaining in the ink cartridges, see the message Printhead failure on page 98.</i>

Message	Explanation and Action
STATUS Maintenance advised	The printer is being used more intensively than the recommended duty cycle. <i>You should contact your local HP dealer or HP service engineer to arrange a service. If you choose to ignore the message, you may continue to use the printer as normal, but may encounter a number of operational or print-quality problems.</i>
STATUS Measuring pattern	The printer is measuring the accuracy calibration print that you just loaded. <i>Wait for the calibration to complete.</i>
STATUS Out of media	The printer has received a file, is ready to print, but has no media loaded. <i>Load appropriate media.</i>
STATUS Pause pending	You have pressed the Pause key but the printer was busy performing a previous action. The printer will pause when it has completed its current action. <i>Wait for the current action to complete.</i>
STATUS Paused	You have pressed the Pause key. The printer will remain paused until you press the Pause key again. <i>Press the Pause key again when you are ready.</i>
STATUS Printing	The printer is printing. <i>Wait for the printing to complete.</i>
STATUS Printing (Special)	The printer is printing with a special print mode controlled by your software rather than by the printer. <i>Wait for the printing to complete.</i>

Message Explanations and Actions

Message	Explanation and Action
STATUS Processing	The printer has received a file from your software and is processing it ready to print. <i>Wait for the printing to complete.</i>
STATUS Ready	The printer is ready to print. <i>Send a file to the printer.</i>
STATUS Ready for media	The printer is ready for you to load media. <i>Load appropriate media.</i>
STATUS Receiving	The printer has received data. <i>Wait for further messages.</i>
STATUS Recovering printhds.	The printer is recovering the printheads after an ink system replacement process (only for UV Pigmented inks), or you have initiated the printhead recovery procedure under Utilities / Service Tests/ Recover Printheads . <i>Wait for the printhead recovery procedure to complete.</i>
STATUS Refilling XmXX s	The printer is filling the printheads. <i>Wait for the process to complete.</i>
STATUS Returning printheads	The ink system replacement process has been cancelled, and the printhead carriage is returning to its station at the right of the printer. <i>Wait until the carriage is in position.</i>
STATUS Roll feed edge trim	The printer is trimming the edge of roll media. <i>Wait until the media has been trimmed.</i>

Message	Explanation and Action
STATUS Waiting nest	Nesting is turned on. The printer is waiting for another print to nest. <i>Send the printer another file for printing.</i>

Message Explanations and Actions

To find how to ...	Go to ...
<i>Install the printer</i>	▶ The Setup Guide.
<i>Connect the printer</i>	▶ The Setup Guide.
<i>Choose media</i>	▶ Chapter 3, Working with Media, in the user's guide.
<i>Load media</i>	▶ Chapter 3, Working with Media, in the user's guide or this guide.
<i>Replace ink system components</i>	▶ Chapter 4, Working with the Ink System, in the user's guide or this guide.
<i>See the printer's current configuration</i>	▶ Chapter 8, Reconfiguring Your Printer, in the user's guide.
<i>Make selections in the front-panel menu</i>	▶ Chapter 2, Using the Front Panel, in the user's guide.
<i>Clear a media jam</i>	▶ Chapter 11, Troubleshooting, in the user's guide.
<i>Solve image quality problems</i>	▶ Chapter 11, Troubleshooting, in the user's guide.
<i>Solve ink system problems</i>	▶ Chapter 11, Troubleshooting, in the user's guide or this guide.
<i>Interpret a front-panel message</i>	▶ Chapter 12, Front-Panel Messages, in the user's guide or this guide.
<i>Order accessories</i>	▶ Chapter 13 Ordering Accessories, in the user's guide
To find any other information	▶ Go to the index of the user's guide.



C4724-90031

Manual Part Number C4724-90031
English
Printed in Europe

This manual is printed on chlorine-free bleached paper