

Overview

HPE Smart Array Gen10 Controllers For HPE ProLiant Server Blades

The HPE Smart Array Gen10 Controllers for the HPE ProLiant Gen10 Server Blades, supporting 12Gb/s SAS and PCIe 3.0, are ideal for maximizing performance while supporting advanced RAID levels with up to 2 GB flash-backed write cache (FBWC). These controllers operate in Mixed Mode which combines RAID and HBA operations simultaneously. The Smart Array Gen10 controller portfolio provides the ability to support internally attached drives with the HPE Smart Array P204i-b SR Gen10 Controller and externally attached drives with the HPE Smart Array P408e-m SR Gen10 Controller. The Smart Array SR Gen10 Controllers also offer encryption for data-at-rest on any drive with HPE Smart Array SR Secure Encryption. The HPE controllers provide enterprise-class storage performance, reliability, security and efficiency needed to address your evolving data storage needs.

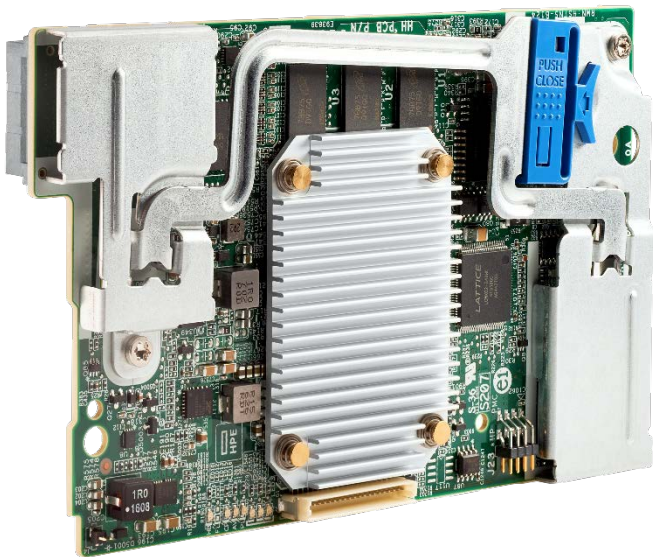

HPE Smart Array P204i-b SR Gen10 Controller

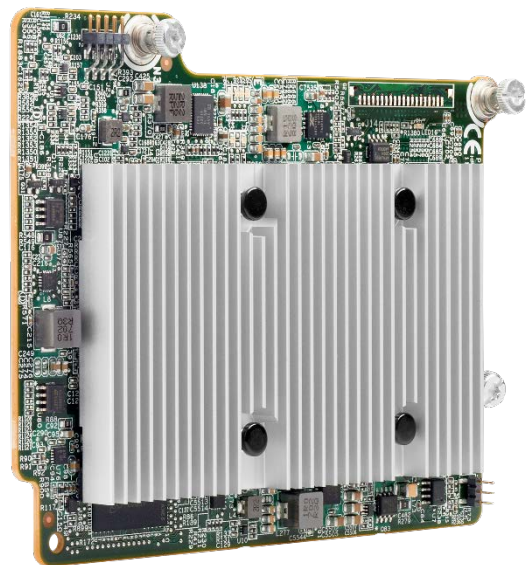

HPE Smart Array P408e-m SR Gen10 Controller

Models

HPE Smart Array P204i-b SR Gen10 (4 Internal Lanes/1GB Cache) 12G SAS Modular Controller	804367-B21
HPE Smart Array P408e-m SR Gen10 (8 External Lanes/2GB Cache) 12G SAS Mezzanine Controller	804381-B21

Kit Contents

Includes controller, documentation information card, warranty statement, and battery required card.

NOTE: The HPE Smart Storage Battery is not included in the kit and is required with Performance RAID controllers (P204i-b and P408e-m).

Compatibility

Server Support

HPE ProLiant BL460c Gen10 Server Blade

Disk Enclosure Support (with P408e-m SR)

HPE MSA 1040 SAN Storage

Overview

HPE MSA 1050 SAN Storage
HPE MSA 2040 SAN Storage
HPE MSA 2050 SAN Storage
HPE D3610 Disk Enclosure
HPE D3710 Disk Enclosure
HPE D6020 Disk Enclosure

Operating System Support

Microsoft Windows Server

Red Hat Enterprise Linux (RHEL)

SUSE Linux Enterprise Server (SLES)

VMware ESXi

Canonical Ubuntu

CentOS

NOTE: HPE Smart Array controllers are supported by the server operating system. For more information on HPE's server operating systems and virtualization software, please visit: <http://www.hpe.com/info/ossupport>

Storage Management Software Suite

HPE Smart Storage Administrator (SSA) GUI
HPE Smart Storage Administrator (SSA) CLI
HPE Smart Storage Administrator (SSA) Scripting
HPE Intelligent Provisioning
UEFI System Utilities (storage configuration)
UEFI Storage RESTful

NOTE: For additional information see the HPE Smart Array SR Gen10 Configuration Guide at: <http://www.hpe.com/info/SmartArrayGen10-docs>

Additional Information

HPE Smart Array SR Gen10 Controllers

For additional information on the features for HPE Smart Array SR Gen10 Controllers, please see the HPE Smart Array SR Gen10 User Guide, HPE Smart Array SR Gen10 Configuration Guide, and HPE Smart Array SR Secure Encryption Installation and User Guide at: <http://www.hpe.com/info/SmartArrayGen10-docs>

Standard Features

Standard Features Table		
Description	HPE Smart Array P204i-b SR Gen10 (4 Internal Lanes/1GB Cache) 12G SAS Modular Controller	HPE Smart Array P408e-m SR Gen10 (8 External Lanes/2GB Cache) 12G SAS Mezzanine Controller
SKU	804367-B21	804381-B21
Ports:		
Internal SAS lanes	4	
External SAS lanes		8
Form Factor:		
Type-b Modular Controller	✓	
Mezzanine Controller		✓
Performance:		
Cache Size (FBWC)	1 GB	2 GB
Read Ahead Caching	✓	✓
Write-Back Caching	✓	✓
Storage Protocol: 12G SAS	✓	✓
Storage Protocol: 6G SATA	✓	✓
I/O slot: PCI Express 3.0	x8 link	x8 link
Key Features		
Maximum Physical Drives (up to)	238	238
Maximum Logical Drives (up to)	64	64
RAID: 0/1/5/6/10/50/60/1 ADM/10 ADM	✓	✓
Mixed Mode: (RAID & HBA)	✓	✓
Boot Mode: Legacy and UEFI	✓	✓
SSD Accelerator	Smart Path	Smart Path
HPE Smart Array SR Secure Encryption	Optional	Optional
HPE Smart Array SR SmartCache		Optional
HPE OneView Support	✓	✓
FIPS 140-2 Level 1 Validation*	✓	✓

*Validation Program FIPS 140-2 Implementation Under Test List. Expected completion is in 2019.

Standard Features

Array Configuration Features

- Expand Array
- Heal Array
- Move Drives
- Re-Mirror Array
- Shrink Array
- Spare Management
- Split Mirrored Array

Logical Drive Configuration Features

- Extend Logical Drive
- Instant Secure Erase
- Migrate RAID/Stripe Size
- Modifying Cache Write Policy
- Move Logical Drive
- Re-enable Failed Logical Drive

Fault Prevention

The following features offer detection of possible failures before they occur, allowing preventive action to be taken:

- Predictive drive failure detects possible drive failure before it occurs, allowing replacement of the component before failure occurs.
- Background surface scan checks drives during inactive periods and automatically remaps bad sectors, ensuring data integrity.
- HPE SmartSSD Wear Gauge reports the amount of lifetime remaining on your SSDs.

Fault Recovery

Minimizes downtime, reconstructs data, and facilitates a quick recovery from drive failure

- Recovery ROM: This feature protects the user from a firmware image corruption by storing a redundant copy of the firmware image. If the active firmware image becomes corrupt, the controller will use the redundant firmware image and continue operating.
- On-Line Spares: There is no limit to the number of spare drives that can be installed prior to drive failure. If a failure occurs, recovery begins with an On-Line Spare and data is reconstructed automatically.
- DRAM ECC detects and corrects data bit errors.

HPE SSD Smart Path

The HPE SSD Smart Path feature included in the Smart Array software stack improves Solid State Disk (SSD) read performance by up to 4x. HPE SSD Smart Path chooses the optimum path to the SSD and accelerates reads for all RAID levels and RAID 0 writes.

HPE Smart Array SR SmartCache (optional license)

The HPE Smart Array SR SmartCache feature is a controller-based read and write caching solution in a DAS environment that caches the most frequently accessed data ("hot" data) onto lower latency SSDs to dynamically accelerate application workloads. The SmartCache architecture is flexible and supports any HPE ProLiant Gen10 HDD for bulk storage and SSD as an accelerator. SmartCache is deployed and managed using the HPE Smart Storage Administrator (HPE SSA). SmartCache requires an optional license (see Related Options section below for more information on the license).

For additional information please visit: <http://www.hpe.com/servers/smartcache>.

Standard Features

HPE Smart Array SR Secure Encryption (optional license)

HPE Smart Array SR Secure Encryption is a Smart Array controller-based data encryption solution that protects sensitive, mission critical data. This is an enterprise-class encryption solution for data-at-rest on any drives attached to the HPE Smart Array controllers including data on the controller cache. Secure Encryption requires an optional license per server (see Related Options for more information on the license).

The solution is available for both local and remote key management mode deployments. Local Key Management Mode is focused on single server deployment where there is one Master key per controller that is managed by the user. Remote Key Management Mode is for enterprise wide deployments from just a few servers to thousands of servers.

For more information on please visit: <http://www.hpe.com/servers/secureencryption>

FIPS 140-2 Cryptographic Module Validation

FIPS provides a security assurance level validation for cryptographic modules. This HPE Smart Array SR Gen10 Controller is a cryptographic module that is currently on the Validation Program FIPS 140-2 Implementation Under Test List. The National Institute of Standards and Technology (NIST) issue the FIPS 140-2 requirements and standards for cryptography modules that include both hardware and software components.

Warranty

The warranty for this device is 3 years parts only.

Warranty Upgrade Options

- Response - Upgrade on-site response from next business day to same day 4 hours.
- Coverage - Extend hours of coverage from 9 hours x 5 days to 24 hours x 7 days.
- Duration - Select duration of coverage for a period of 1, 3, or 5 years.
- Warranty upgrade options can come in the form of Care Packs, which are sold at the HPE System level to which this product attaches.

Naming Framework

The Gen10 controller naming framework is illustrated below to help simplify controller identification.

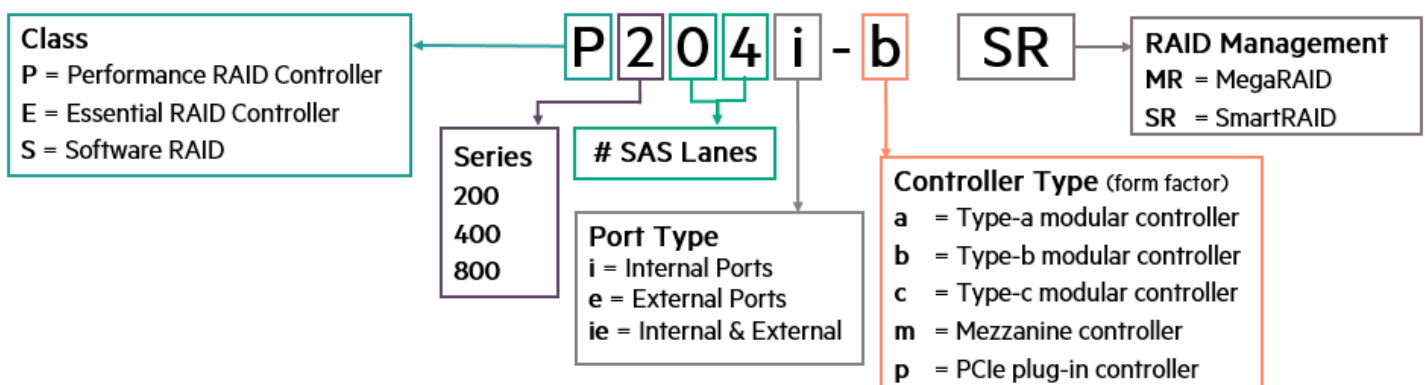

Service and Support

HPE Support Services

Protect your business beyond warranty with HPE Support Services

HPE Pointnext provides a comprehensive portfolio including Advisory and Transformational, Professional, and Operational Services to help accelerate your digital transformation. From the onset of your transformation journey, Advisory and Transformational Services focus on designing the transformation and creating a solution roadmap. Professional Services specializes in creative configurations with flawless and on-time implementation, and on-budget execution. Finally, operational services provides innovative new approaches like Flexible Capacity and Datacenter Care, to keep your business at peak performance. HPE is ready to bring together all the pieces of the puzzle for you, with an eye on the future, and make the complex simple.

Recommended Support

HPE Proactive Care* with 24x7 coverage, three year Support Service

HPE Proactive Care gives customers an enhanced call experience. When your products are connected to HPE, Proactive Care helps prevent problems and maintains IT stability by utilizing personalized proactive reports with recommendations and advice. This Service combines three years proactive reporting and advice with our 24x7 coverage, four hour hardware response time when there is a problem. This service also includes collaborative software support for Independent Software Vendors (ISVs), (Red Hat, VMWare, Microsoft, etc.) running on your HPE servers.

<https://www.hpe.com/h20195/v2/GetPDF.aspx/4AA3-8855ENW.pdf>

HPE Proactive Care* with 6 hour call-to-repair commitment, three year Support Service

HPE Proactive Care gives customers an enhanced call experience. When your products are connected to HPE, Proactive Care helps prevent problems and maintains IT stability by utilizing personalized proactive reports with recommendations and advice. This Service combines three years' proactive reporting and advice with our highest level of hardware support - HPE's 24x7, six hour hardware call-to-repair. HPE is the only leading manufacturer who makes this level of coverage available as a standard service offering for your most valuable servers. This service also includes collaborative software support for Independent Software Vendors (ISVs), (Red Hat, VMWare, Microsoft, etc.) running on your HPE servers.

<https://www.hpe.com/h20195/v2/GetPDF.aspx/4AA3-8855ENW.pdf>

*HPE Proactive Care and HPE Proactive Care Advanced require that the customer connect their devices to make the most of these services and receive all the deliverables.

HPE Education Services

Keep your IT staff trained making sure they have the right skills to deliver on your business outcomes. Book on a class today and learn how to get the most from your technology investment. <http://www.hpe.com/ww/learn>

HPE Support Center

The HPE Support Center is a personalized online support portal with access to information, tools and experts to support HPE business products. Submit support cases online, chat with HPE experts, access support resources or collaborate with peers.

Learn more <http://www.hpe.com/support/hpesc>

The HPE Support Center Mobile App* allows you to resolve issues yourself or quickly connect to an agent for live support. Now, you can get access to personalized IT support anywhere, anytime.

HPE Insight Remote Support and HPE Support Center are available at no additional cost with a HPE warranty, HPE Support Service or HPE contractual support agreement.

*HPE Support Center Mobile App is subject to local availability

Service and Support

Parts and Materials

Hewlett Packard Enterprise will provide HPE-supported replacement parts and materials necessary to maintain the covered hardware product in operating condition, including parts and materials for available and recommended engineering improvements.

Parts and components that have reached their maximum supported lifetime and/or the maximum usage limitations as set forth in the manufacturer's operating manual, product quick-specs, or the technical product data sheet will not be provided, repaired, or replaced as part of these services.

The defective media retention service feature option applies only to Disk or eligible SSD/Flash Drives replaced by Hewlett Packard Enterprise due to malfunction.

Related Services

HPE Server Hardware Installation

Provides for the basic hardware installation of HPE branded servers, storage devices and networking options to assist you in bringing your new hardware into operation in a timely and professional manner.

<https://www.hpe.com/h20195/V2/GetPDF.aspx/5981-9356EN.pdf>

HPE Installation and Startup Service provides for the installation and startup of HPE technology including BladeSystems, C-Class enclosure, HPE ProLiant c-Class and Integrity server blades, storage blades, SAN switch blades, HPE Virtual Connect modules (Ethernet and Fibre Channel), Ethernet network interconnects, and InfiniBand, as well as the installation of one supported operating system type (Windows® or Linux).

NOTE: The Smart Array controller is covered under the HPE Service Contract applied to the HPE ProLiant Server. No separate HPE support services need to be purchased.

Warranty and Support Services will extend to include HPE options configured with your server or storage device. The price of support service is not impacted by configuration details. HPE sourced options that are compatible with your product will be covered under your server support at the same level of coverage allowing you to upgrade freely. Installation for HPE options is available as needed. To keep support costs low for everyone, some high value options will require additional support. Additional support is only required on select high value workload accelerators, fibre switches, InfiniBand and UPS batteries over 12KVA. See the specific high value options that require additional support [HERE](#)

Additional Service Information

<http://www.hpe.com/services>

Related Options

HPE Smart Array SR SmartCache

Single-Server License

Used to purchase a license for one server.

Contains one license per server, a printed license entitlement certificate, end user license agreement, and license key installation card **delivered via physical shipment**. The license entitlement certificate must be redeemed online or via fax in order to obtain the license activation key(s). Include one year of 24x7 HPE Software Technical Support Services.

HPE Smart Array SR SmartCache (Single Key/Single Server) LTU

D7S26A

Flexible-Quantity License

Used to purchase multiple licenses with a single activation key.

Contains license(s) for a customer defined quantity of servers, a license entitlement certificate for the quantity of licenses purchased, end user license agreement, and license key installation card **delivered via physical shipment**. The license entitlement certificate must be redeemed online or via fax in order to obtain the license activation key(s). Include one year of 24x7 HPE Software Technical Support Services.

HPE Smart Array SR SmartCache (Single Key/Multiple Servers) LTU

D7S27A

Flexible-Quantity Electronic License

Used to purchase multiple licenses with a single activation key.

Contains license(s) for a customer defined quantity of servers, a license entitlement certificate for the quantity of licenses purchased, end user license agreement, and license key installation information **delivered via e-mail**. The license entitlement certificate must be redeemed online or via fax in order to obtain the license activation key(s). Include one year of 24x7 HPE Software Technical Support Services.

HPE Smart Array SR SmartCache (Single Key/Multiple Servers) E-LTU

D7S27AAE

NOTE: For more information please visit: <http://www.hpe.com/servers/smartcache>

HPE Smart Array SR Secure Encryption

HPE Smart Array SR Secure Encryption (Data at Rest Encryption/per Server Entitlement) E-LTU

Q2F26AAE

NOTE: HPE Smart Array SR Secure Encryption licensing is based on the number of servers requiring encryption for direct attached storage.

NOTE: For more information visit: <http://www.hpe.com/servers/secureencryption>

or see the HPE Smart Array SR Secure Encryption Installation and User Guide at:

<http://www.hpe.com/info/SmartArrayGen10-docs>

HPE Smart Storage Battery

HPE 12W Smart Storage Battery (up to 3 Devices) for BladeSystem Server

P01363-B21

NOTE: Smart Array Gen10 controllers are supported by the HPE Smart Storage Battery. This battery supports multiple devices and is sold separately.

Summary of Changes

Date	Version History	Action	Description of Change
01-Oct-2018	Version 2	Changed	Overview, Standard Features and Related Options were revised.
04-Sep-2018	Version 1	New	New QuickSpecs



© Copyright 2018 Hewlett Packard Enterprise Development L.P. The information contained herein is subject to change without notice. The only warranties for Hewlett Packard Enterprise products and services are set forth in the express warranty statements accompanying such products and services. Nothing herein should be construed as constituting an additional warranty. Hewlett Packard Enterprise shall not be liable for technical or editorial errors or omissions contained herein.

a00047735enw - 16272 - Worldwide - V2 - 1-October-2018