



Equipment Type: Dual Distal Superficial / Rockwell Hardness Tester

Model: **HR-145**

Electrical Requirements: 110 or 220 Volts (single-phase)

Frequency: 50/60 Hz

Manual Revision Date: April 2014

Please read this instruction manual carefully and follow all installation, operating and safety guidelines.



HR-145 Dual Superficial / Rockwell Hardness Tester

----- ▲ INSTRUCTION MANUAL

3601 E. 34th St. Tucson, AZ 85713 USA Tel. +1 520-882-6598 Fax +1 520-882-6599 email: pace@metallographic.com Web: <http://www.metallographic.com>

Contents

| | PAGE |
|---|------|
| Warranty | ii |
| 1.0 Product Description | 1 |
| 2.0 Unpacking, Shipping and Installation | 4 |
| 3.0 Safety Guidelines | 18 |
| 4.0 Operation | 19 |
| 5.0 Maintenance | 23 |
| 6.0 Trouble Shooting | 24 |
| 7.0 Spare Parts | 25 |
| 8.0 Hardness Testing Basics | 30 |
| 9.0 Appendix RS232 Connector | 32 |

Please read this instruction manual carefully and follow all installation, operating and safety guidelines.



HR-145 Dual Superficial / Rockwell Hardness Tester

----- ▲ INSTRUCTION MANUAL

3601 E. 34th St. Tucson, AZ 85713 USA Tel. +1 520-882-6598 Fax +1 520-882-6599 email: pace@metallographic.com Web: <http://www.metallographic.com>

WARRANTY

Terms and Conditions applying to all PACE Technologies Products

1. LIMITED WARRANTY AND DISCLAIMER:

PACE Technologies Products are warranted for one year from the purchase date to be free from defects in material and workmanship under correct use, normal operating conditions, and proper application. PACE Technologies obligation under this warranty shall be limited to the repair or exchange, at PACE Technologies option, of any PACE Technologies Product or part which proves to be defective as provided herein. PACE Technologies reserves the right to either inspect the product at Buyer's location or require it to be returned to the factory for inspection. Buyer is responsible for freight to and from factory on all warranty claims. The above warranty does not extend to goods damaged or subjected to accident, abuse or misuse after release from PACE Technologies warehouse, nor goods altered or repaired by anyone other than specifically authorized PACE Technologies representatives. PACE Technologies shall not in any way be responsible for the consequences of any alteration, modification or misuse unless previously approved in writing by an officer of PACE Technologies.

PACE TECHNOLOGIES MAKES NO EXPRESS WARRANTIES OTHER THAN THOSE WHICH ARE SPECIFICALLY DESCRIBED HEREIN. Any description of the goods sold hereunder, including any reference to Buyer's specifications and any description in catalogs, circulars and other written material published by PACE Technologies, is the sole purpose of identifying such goods and shall not create an express warranty that the goods shall conform to such description.

THIS WARRANTY IS EXPRESSLY IN LIEU OF ALL OTHER WARRANTIES, EXPRESSED OR IMPLIED. THERE ARE NO IMPLIED WARRANTIES OF MERCHANTABILITY OR FITNESS FOR PARTICULAR PURPOSE. THIS WARRANTY STATES PACE TECHNOLOGIES ENTIRE AND EXCLUSIVE LIABILITY AND BUYER'S EXCLUSIVE REMEDY FOR ANY CLAIM FOR DAMAGES IN CONNECTIONS WITH PACE TECHNOLOGIES PRODUCTS. PACE TECHNOLOGIES WILL IN NO EVENT BE LIABLE FOR INCIDENTAL OR CONSEQUENTIAL DAMAGES WHATSOEVER, NOR FOR ANY SUM IN EXCESS OF THE PURCHASE PRICE.

2. LIABILITY CAP:

PACE Technologies maximum aggregate liability for loss and damage arising under, resulting from or in connection with the supply or use of the Equipment and Consumables provided under this purchase, or from the performance or breach of any obligation (s) imposed hereunder, whether such liability arises from any one or more claims or actions for breach of contract, tort, (including negligence), delayed completion, warranty, indemnity, strict liability or otherwise, unless otherwise limited by the terms hereof, shall be limited to one hundred percent (100%) of the purchase price.

3. DELIVERY:

Customer assumes and shall bear the risk of all loss or damage to the Products from every cause whatsoever, whether or not insured, and title to such Products shall pass to Customer upon PACE Technologies delivery of the Products to the common carrier of Pace Technologies choice, or the carrier specified in writing by Customer, for shipment to Customer. Any claims for breakage, loss, delay, or damage shall be made to the carrier by the Customer and Pace Technologies will render customer reasonable assistance in prosecuting such claims.

Please read this instruction manual carefully and follow all installation, operating and safety guidelines. ii



HR-145 Dual Superficial / Rockwell Hardness Tester

----- ▲ INSTRUCTION MANUAL

3601 E. 34th St. Tucson, AZ 85713 USA Tel. +1 520-882-6598 Fax +1 520-882-6599 email: pace@metallographic.com Web: <http://www.metallographic.com>

4. ACCEPTANCE:

Customer shall inspect the Products promptly upon receipt of delivery. Unless customer objects in writing within thirty (30) business days thereafter, customer shall be deemed to have accepted the Products. All claims for damages, errors, or shortage in Products delivered shall be made by Customer in writing within such five (5) business day period. Failure to make any claim timely shall constitute acceptance of the Products.

5. PAYMENT:

Customer agrees to provide timely payment for the Products in accordance with the terms of payment set forth on the reverse side hereof or in any proposal submitted herewith. If any payment is not paid on or before its due date, Customer shall pay interest on such late payment from the due date until paid at the lesser of 12% per annum or the maximum rate allowed by law.

6. DEFAULT:

If Buyer is in default (including, but not limited to, the failure by Buyer to pay all amounts due and payable to Seller) under the work or purchase order or any other agreement between Buyer and Seller, Buyer's rights under the warranty shall be suspended during any period of such default and the original warranty period will not be extended beyond its original expiration date despite such suspension of warranty rights.

7. MISCELLANEOUS PROVISIONS:

This agreement has been made in and shall be governed by the laws of the State of Arizona. These terms and conditions and the description of the Products on the reverse side hereof or in any proposal submitted herewith constitute the entire agreement and understanding of the parties with respect to this sale and supersede all prior and contemporaneous agreements or understandings, inducements or representations, expressed or implied, written or oral, between the parties with respect hereto. Any term or provision of this Agreement may be amended, and any observance of any term of this Agreement may be waived, only by a writing signed by the party to be bound. The waiver by a party of any breach shall not be deemed to constitute a waiver of any other breach. Should suit be brought on this Agreement, the prevailing party shall be entitled to recover its reasonable attorneys' fees and other costs of suit including costs and attorneys' fees incurred on appeal or in collection of any judgment.

1.0 Product Description

1.1 General Description

1. LED screen
2. Operating keys
3. Indenter fastening screw
4. Indenter
5. Anvil
6. Up and Down lead screw
7. Screw adjustment wheel
8. Leveling feet
9. Upper cover
10. Back cover
11. Rockwell/ Superficial selection knob
12. Weight adjustment knob
13. Power switch
14. Power cord
15. RS232 connector
16. Fuse
17. Printer

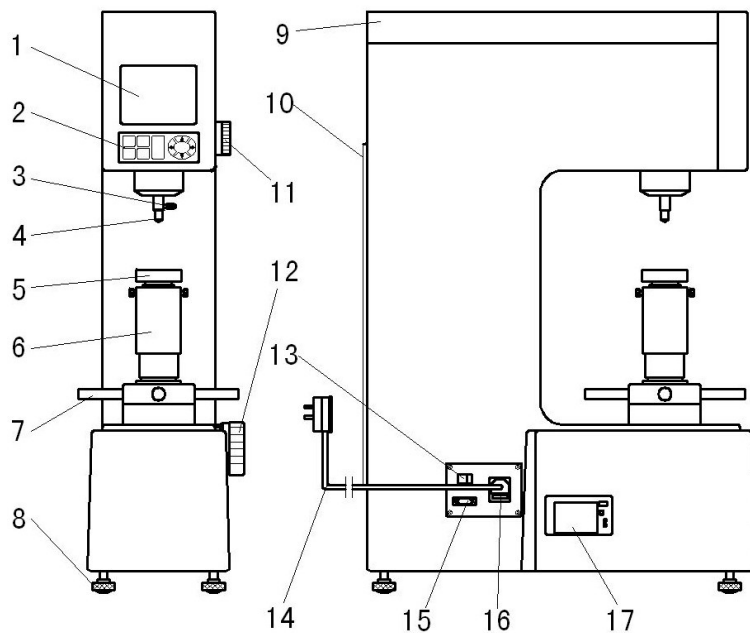

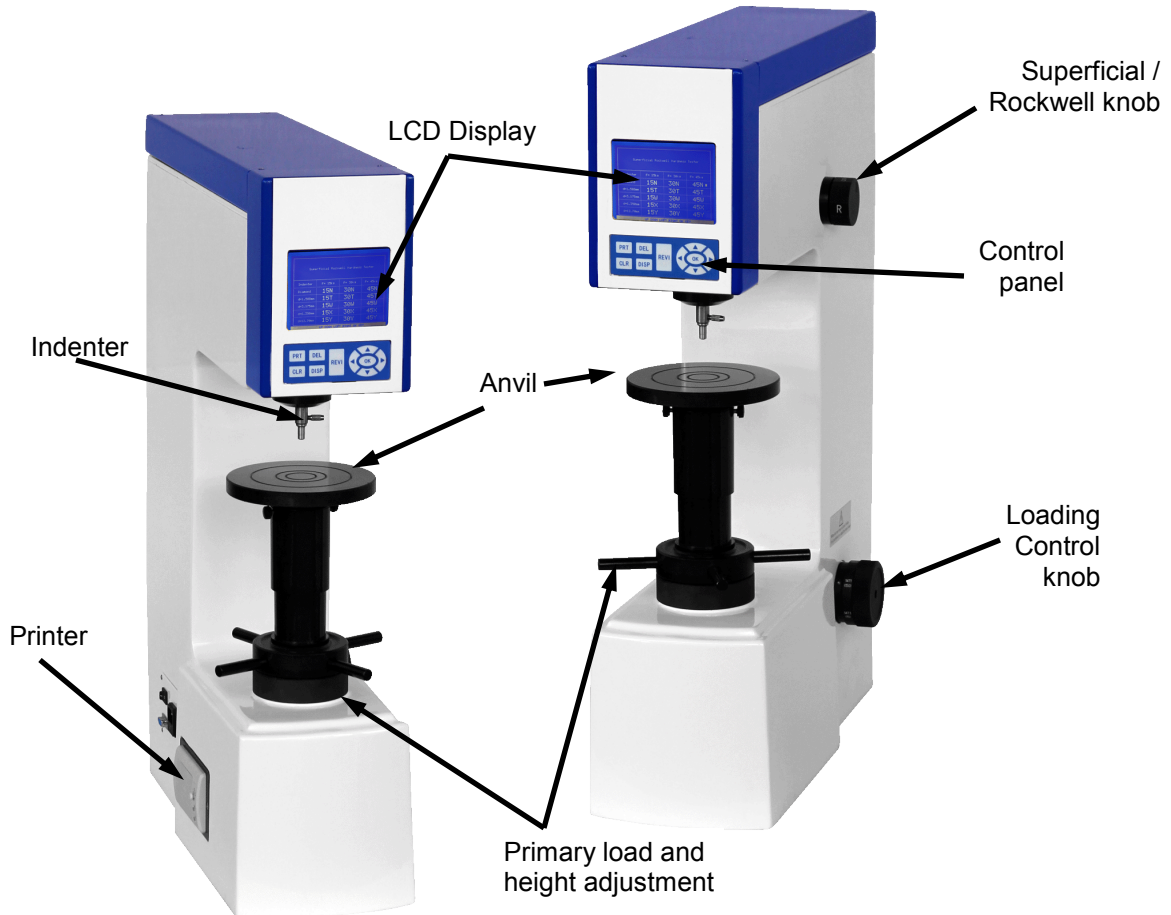

The HR-145 dual Superficial / Rockwell hardness testing for evaluating metallographic specimen hardness.

The HR-145 dual Superficial / Rockwell hardness tester with a load range of 15 kg 45 kg for Superficial Rockwell testing and 60 kg to 150 kg for Rockwell testing.

1.2 Technical Specifications

| | |
|---|--|
| Electrical specifications: | 110 or 220V single-phase (50/60 Hz) |
| Test forces: | Superficial Rockwell 15 kg 30 kg 45 kg Rockwell 60 kg 100 kg 150 kg |
| Dwell time of test force: | 2-60 seconds |
| Max. height of specimen: | 175 mm (7-inches) |
| Distance from indentation: center to frame | 165 mm (6.5-inches) |
| Weight: | Approx. 175 lbs (80 kg) |
| Dimensions (WxHxD): | Approx. 21" x 8.5" x 30.5" (525 mm x 210 mm x 770 mm) |
| Working temperature: | 70° - 85°F (23 - 28°C) |
| Indenter (included) | Diamond Rockwell 1.5875 mm ball |

2.0 Unpacking, Shipping and Installation

2.1 Unpacking

Unit is delivered in a box. Unpack and check for completeness of parts.

Measures WxHxD: 26"x15"x36" (660x380x915 mm)

Weight: Approximately 220 lbs (100 kg)

2.2 Shipping

When moving box, lift from bottom.



! **Caution:** Heavy equipment. Take care to avoid bodily injury.

2.3 Installation

! Install unit carefully! Improper installation voids warranty.

The **HR-145** should be placed on a flat stable vibration free surface. If tall or high samples are to be tested so that the up / down lead screw is lowered significantly, a hole will need to be made in the table (see drawing for specifications - mm)

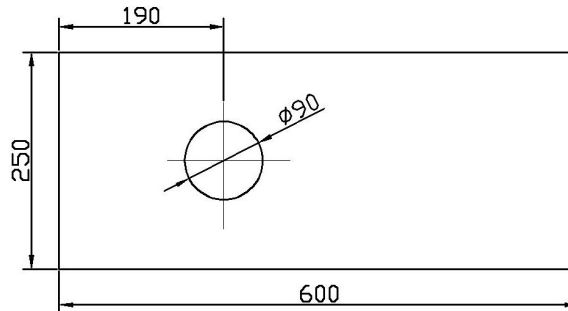

2.3.1 Install leveling feet



Attach four leveling feet and use bubble level on anvil to level unit (see section 2.3.5)

2.3.2 Remove shipping securing tie downs

Open top and back covers
-Remove ties



Remove rubber bands

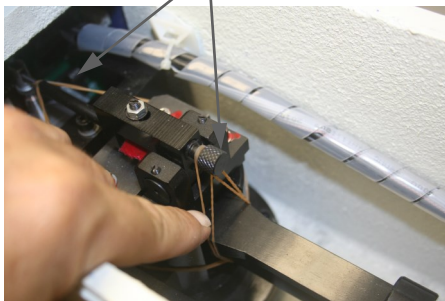

Remove felt pad

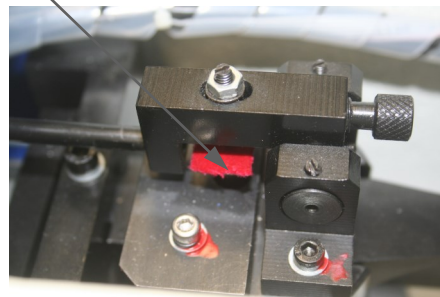

2.3.3 Installing weight stack

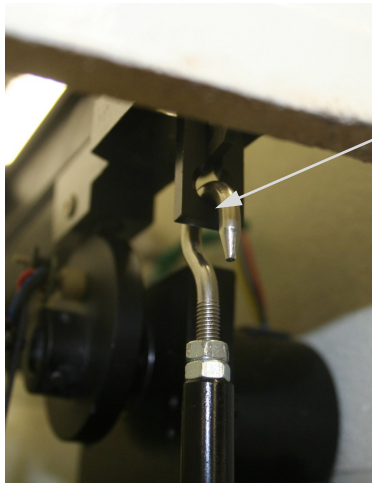

Hang weight stack holder onto loading beam

Load weights onto holder so that the pegs on the weight are aligned with the forks on the holder

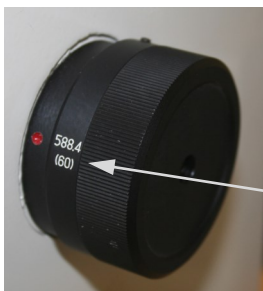
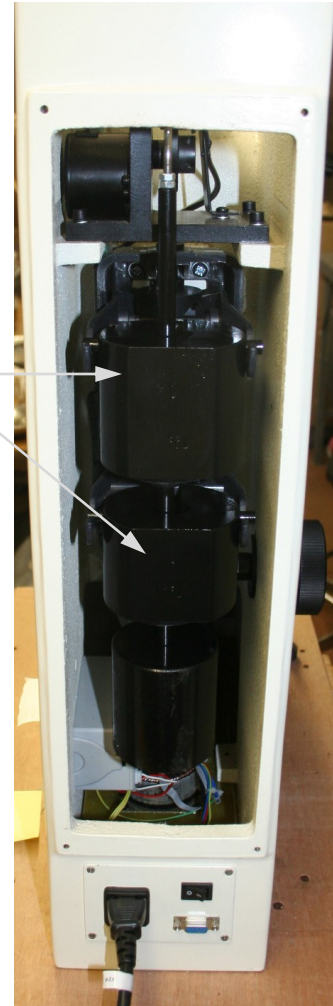
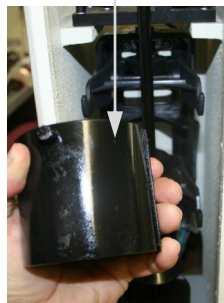

Test the load stack to verify that the weights are being lifted and that they hang freely depending on the load set on the control knob

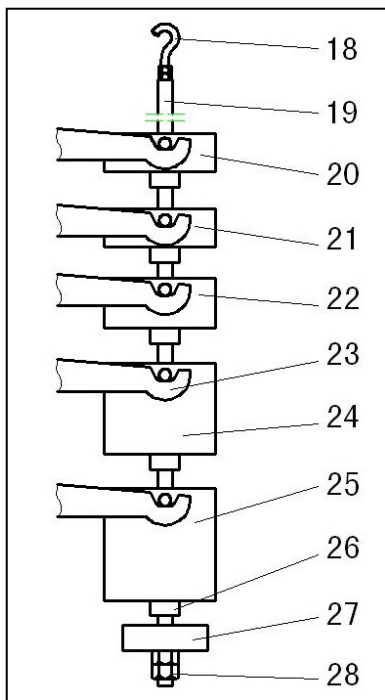

- 18. Hook
- 19. Hanging rod
- 20. Weight 1
- 21. Weight 2
- 22. Weight 3
- 23. Fork lifter
- 24. Weight 4
- 25. Weight 5
- 26. Tray
- 27. Weight 6
- 28. Retaining nut

Test force for respective weights

| Scale | Test Force (N) | Graduated value on Load-Change hand wheel | Weight |
|-------|----------------|---|--|
| 15N | 15 kg | | Hanging rod + Weight 6 |
| 30N | 30 kg | | Hanging rod + Weight 6 + 1 |
| 45N | 45 kg | | Hanging rod + Weight 6 + 1 + 2 |
| HRA | 588.4 (60 kg) | 588.4 (60) | Hanging rod + Weight 6 + 1 + 2 + 3 |
| HRB | 980.7 (100 kg) | 980.7 (100) | Hanging rod + Weight 6 + 1 + 2 + 3 + 4 |
| HRC | 1471 (150 kg) | 1471 (150) | Hanging rod + Weight 6 + 1 + 2 + 3 + 4 + 5 |

2.3.4 Installing Anvil Stage



Insert anvil into up/down screw feed



Raise cover and tighten thumb screws

2.3.5 Leveling unit

Place bubble level on stage and adjust feet height to level the unit



2.3.6 Inserting Indenter



Align flat end of indenter
shank with the holding
screw



After loading indenter - run a sample indent to
properly set the indenter

2.3.7a Calibration (Rockwell)

- 23. Connecting rod
- 24. Adjustment screw
- 25. Fine tuning adjustment knob

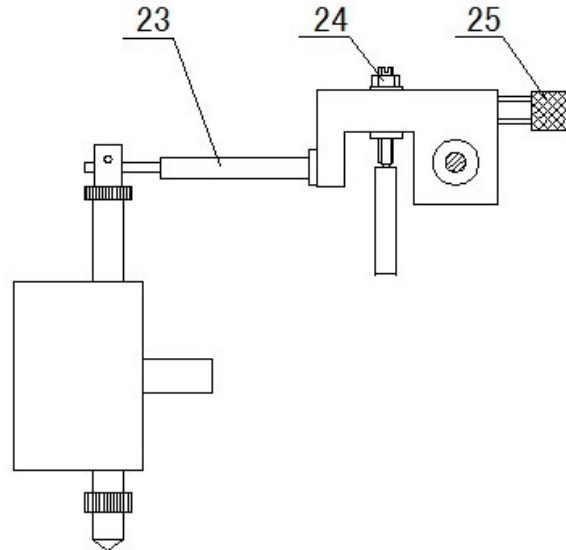

To calibrate to test blocks - hold screw in place at (24) and loosen nut, adjust screw (25)

For values reading low - adjust screw clockwise

For values reading high - adjust screw counter-clockwise

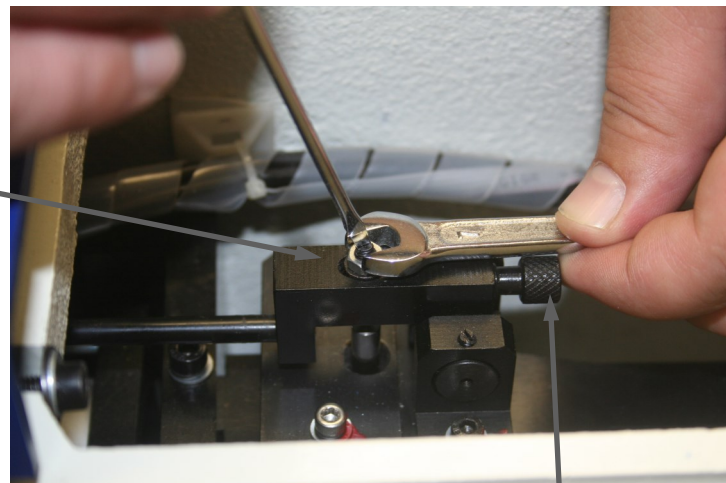

Adjustment knob

2.3.7b Calibration (Superficial scale)

If the superficial values are not correlating to test blocks after calibrating the Rockwell use the following calibration procedure.

1. Verify that the Rockwell hardness is calibrated to certified test blocks
2. Superficial Rockwell is calibrated through the control panel
 - a. Press Menu Key (REV1) — Print Key (PRT) — Enter the revised value interface
15N 30N 45N
15T 30T 45T

Choose the scale to adjust and press the up/down key to adjust the value

Low 0-50 Low hardness revision
High 50-100 high hardness revision

3601 E. 34th St. Tucson, AZ 85713 USA Tel. +1 520-882-6598 Fax +1 520-882-6599 email: pace@metallographic.com Web: http://www.metallographic.com

2.3.8 Key Pad Functions

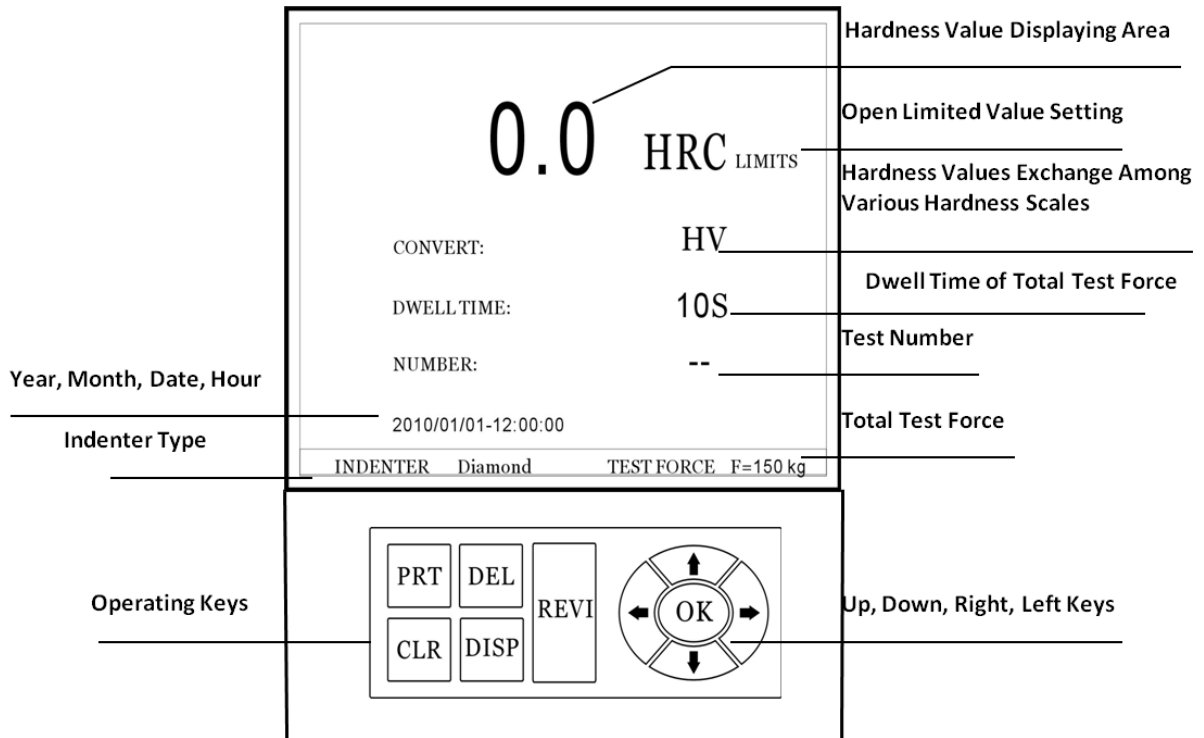

2.3.8.1 <REVI> Key's Function

Press <REVI> Key to display the LCD screen to the right. The cursor will flash. Press the UP or DOWN key to select the item in the menu and then press <OK> to enter.

| | |
|---------|---------------------|
| LIMITS | GO/NG |
| SCALES | HRC |
| TIME | 2010/11/11-12:00:00 |
| DWELL | 10S |
| CONVERT | HV |
| EXIT | ■ |

F

2.3.8.1a CONVERT:

Converts hardness values to selected scale.

Press <REVI> key to enter system setting menu. Select <CONVERT> from the menu and press <OK> to obtain selection table. Move cursor to the desired scale and press <OK>. Press <OK> key again to return to main screen.

| HARD | | SOFT | |
|------|-----|------|-----|
| HV ■ | HRD | HRF | 45T |
| HRC | 15N | HRG | HBW |
| HK | 30N | HRE | HV |
| HBW | 45N | HRK | HK |
| HRA | HS | 15T | HS |
| HRB | | 30T | HRB |

UP DOWN OK KEY

Typical scales are listed as:

HARD - Ferrous metals;

SOFT - Non-ferrous metals.

2.3.8.1b DWELL: (Dwell time setting)

Set the dwell time and press <OK> to save and to return to the main page.

2.3.8.1c TIME: (Date / clock setting)

Set clock setter for year, month, date, hour, minute and press <OK> to save and to return to the main page.

2.3.8.1d SCALES:

(Selection of Rockwell or Superficial Rockwell scales)

Select the Rockwell hardness scales (see top right table), or select the Superficial Rockwell hardness scales (see lower right table).

| Metallic Rockwell Hardness Tester | | | |
|-----------------------------------|--------|---------|---------|
| Indenter | F=60kg | F=100kg | F=150kg |
| Diamond | HRA | HRD | HRC ■ |
| D=1.588mm | HRF | HRB | HRG |
| D=3.175mm | HRH | HRE | HRK |
| D=6.350mm | HRL | HRM | HRP |
| D=12.70mm | HRR | HRS | HRV |

UP DOWN LEFT RIGHT OK KEY

| Superficial Rockwell Hardness Tester | | | |
|--------------------------------------|--------|--------|--------|
| Indenter | F=15kg | F=30kg | F=45kg |
| Diamond | 15N | 30N | 45N ■ |
| D=1.588mm | 15T | 30T | 45T |
| D=3.175mm | 15W | 30W | 45W |
| D=6.350mm | 15X | 30X | 45X |
| D=12.70mm | 15Y | 30Y | 45Y |

UP DOWN LEFT RIGHT OK KEY

2.3.8.1e LIMITS: (Limit values setting)

Upper and lower limits can be set in this mode. If a hardness value is within the upper and lower limits a “GO” (qualified) value will be displayed and printed. For values outside of the set range a “NG” (unqualified) value will be higher than the lower limit.

To turn “ON” use cursor to set upper and lower limit. Press <OK> to set value.

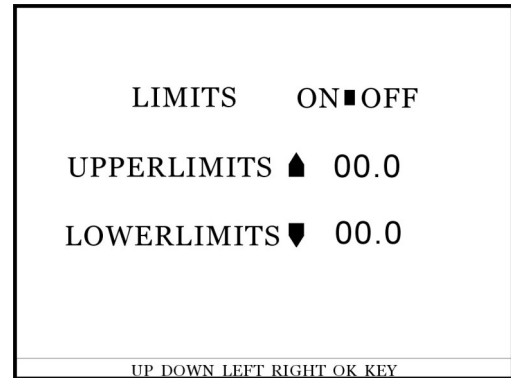

2.3.8.2



Zero's value



Delete the present measured hardness value



Prints hardness value, average value, range, number of tests, date



Display Key. When the number of operations ≥ 2 , press this key to display the hardness data of present test. To store this page, press "SAVE" key to store and return to main page. Only 6 pages can be saved (Page No. 00~05). When page No.7 is saved the first page will overflow. After power off the hardness tester, all saved pages will be eliminated.



Confirmation Key - Press to enter data



Up and Down cursor control



Left and Right cursor control

3.0 Safety Guidelines

3.1 Warning Sign

! This sign points to special safety features on the machine.

3.2 Safety Precautions

! Careful attention to this instruction manual and the recommended safety guidelines is essential for the safe operation of the **HR-145**.

! Proper operator training is required for operation of the **HR-145**. Any unauthorized mechanical and electrical change, as well as improper operation, voids all warranty claims. All service issues need to be reported to the manufacturer / supplier.

! Operate unit as specified in this manual.

! Disconnect power before opening unit.

! Lower stage to avoid damaging indenter when not in use.

! Cover unit with dust cover when not in use to eliminate dust contamination.

3.3 Emergency Statement

Always follow proper operational guidelines and avoid contact with lubricants and abrasives.

4.0 Operation

1. Mount the sample so it is flat on the stage. For non-parallel mounts a leveling vice is recommended (optional)
 - Sample should be clean
 - Minimum thickness should be 10X the depth of the indentation
 - Do not test samples in a metallographic mounts
 - Sample must be secured so it does not move during loading, otherwise the indenter can be damaged

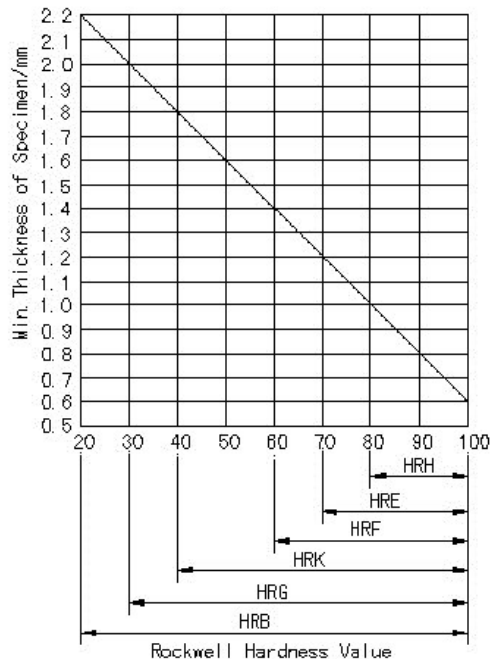
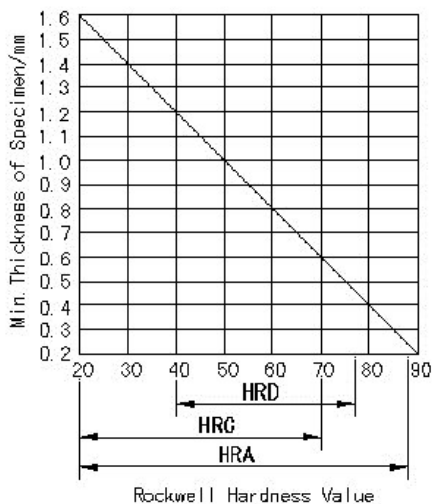

2. Turn on the HR-145
3. Select appropriate load and indenter (see following table).

4.0 Operation (continued)

Rockwell Hardness Testing

| Scale | Indenter Type | Initial Test Force | Total Test Force (N) | Application | |
|-------|---|--------------------|--|--|---|
| HRA | Diamond Indenter | 98.07 N (10 kg) | 588.4 (60 kg) | Hard alloys, carbide steel, surface quenched steel, carburized steel plate | |
| HRD | | | 980.7 (100 kg) | | Steel sheet, surface quenched steel |
| HRC | | | 1471 (150 kg) | | Quenched steel, tempered steel, hard cast iron |
| HRF | Ball Indenter φ1.5875mm (1/16 inch) | | 588.4 (60 kg) | Cast iron, aluminum, magnesium alloy, bearing alloy, annealed copper alloy, mild steel sheet | |
| HRB | | | 980.7 (100 kg) | | Mild steel, aluminum alloy, copper alloy, malleable cast iron, annealed steel |
| HRG | | | 1471 (150 kg) | | Phosphor bronze, beryllium bronze, malleable cast iron |
| HRH | Ball Indenter φ3.175mm (1/8 inch) | | 588.4 (60 kg) | Aluminum, zinc, lead, etc | |
| HRK | | | 980.7 (100 kg) | | Bearing alloy, tin, hard plastics and other soft materials |
| HRE | | | 1471 (150 kg) | | |
| HRL | Ball Indenter φ12.7mm (1/2 inch) | 588.4 (60 kg) | Bearing alloy, tin, hard plastics and other soft materials | | |
| HRM | | 980.7 (100 kg) | | | |
| HRP | | 1471 (150 kg) | | | |

3601 E. 34th St. Tucson, AZ 85713 USA Tel. +1 520-882-6598 Fax +1 520-882-6599 email: pace@metallographic.com Web: http://www.metallographic.com

Superficial Rockwell Hardness Testing

| Scales | Indenters | Initial Test Force (N) | Total Test Force (N) | Application Examples |
|--------|-------------------------------------|------------------------|----------------------|---|
| 15N | Diamond Indenter | 29.42 (3 kg) | 147.1 (15N) | Hard alloy steel, nitride steel, carburized steel, various heavy steel plate, etc. |
| 30N | | | 294.2 (30N) | Surface quenched steel, carburized steel, knife blades, thin steel plate, etc. |
| 45N | | | 441.3 (45N) | Quenched steel, tempered steel, hard cast iron, etc. |
| 15T | Ball indenter 1.5875 mm (1/16 inch) | | 147.1 (15N) | Annealed copper alloy, mild steel sheet, brass, bronze, etc. |
| 30T | | | 294.2 (30N) | Mild steel sheet, aluminum alloys, copper alloys, brass and bronze, malleable cast iron, etc. |
| 45T | | | 441.3 (45N) | |
| 15W | Ball indenter 3.175 mm (1/8 inch) | | 147.1 (15N) | Annealed copper alloy, mild steel, etc |
| 30W | | | 294.2 (30N) | Aluminum and aluminum alloys, magnesium, mild steel, etc. |
| 45W | | | 441.3 (45N) | Zinc, aluminum, lead, bronze, beryllium bronze, etc. |
| 15X | Ball indenter 6.35 mm (1/4 inch) | | 147.1 (15N) | Aluminum, tin, zinc, soft metals, plastics, hard, etc. |
| 30X | | | 294.2 (30N) | |
| 45X | | | 441.3 (45N) | |
| 15Y | Ball indenter 12.7 mm (1/2 inch) | 147.1 (15N) | | |
| 30Y | | 294.2 (30N) | | |
| 45Y | | 441.3 (45N) | | |

4.0 Operation (continued)

4. Rotate Hand Wheel clockwise to move sample into indenter

-Continue to turn wheel slowly to apply the initial test load.

-When the buzzer sounds stop turning the initial load and let the servo motor apply the test force for the preset Dwell time (If the initial load is too fast or a buzzer will produce a long sound indicating an error in the measurement. For this situation lower the sample and move the sample to a new location and then re-apply the initial test)

IMPT: Do not rotate the hand wheel or move the specimen during application of the main load as this may damage the instrument.

5. Turn rotating wheel counter-clockwise to lower the sample. Move the sample to the second test location.

-NOTE: the first measurement is done to set the indenter and is not included in the data

6. To print, remove load or back off sample from indenter and press "PRT" to print the output

PRECAUTIONS

Clamp the sample properly on the self-leveling vice. This will level the sample perpendicular to the indenter.

Important : This is very important as a tilted sample can damage the indenter. it is also very important to have a flat specimen. A rounded specimen will have varying height as it moves and can touch and damage the indenter.

Important : Take utmost care to insure that the sample or the leveling vice does not touch the indenter as this may damage the indenter

5.0 Maintenance

5.1 Introduction

The **HR-145** requires very minimal maintenance. However, to increase the life of the Dual Rockwell/ Superficial hardness tester, it is suggested that the unit be covered when not in use.

5.2 Cleaning outside cabinet

The cabinet should be cleaned occasionally with a moistened cloth. Do not use any chemicals or cleaning abrasives.

6.0 Trouble Shooting

More extensive trouble shooting, repair guides, video's, parts list are provided online at www.metallographic.com or



<http://www.metallographic.com/PACE-service/Rockwell-service.html>

| Phenomenon | Possible Causes | Method Used |
|--|---|---|
| LCD does not turn on | <ol style="list-style-type: none"> 1. No power 2. The fuse is blown. | <ol style="list-style-type: none"> 1. Check the power cable. 2. Change the fuse. |
| When the tester is on, the keys do not work | The instrument is not in working state. | When the tester is turned on, wait until the instrument returns to the working state. |
| The Up / Down Lead Screw is hard to move | The space between the Up / Down Lead Screws are blocked by the thread ends or dirt | Remove the protecting cover for the Up / Down Lead Screw and clean the screw threads |
| The deviation of the displaying hardness value is too great. | <ol style="list-style-type: none"> 1. The indenter is damaged 2. The Weights are not installed in order. 3. The tester is not placed in the horizontal level and the weights are touching the inside wall of instrument body. 4. The total test force or the indenter are not correct. 5. The protecting cover of Up/ Down Lead Screw is too high over the supporting plane of the Testing Table | <ol style="list-style-type: none"> 1. Change the diamond indenter or the ball indenter. 2. Install the weights properly 3. Level the tester 4. Choose the appropriate testing force and indenter 5. Lower the protecting cover and clean the Up and Down Lead Screw. |
| LCD hard to read | <ol style="list-style-type: none"> 1. LCD display brightness not set properly | <ol style="list-style-type: none"> 1. Adjust blue pod adjustment on back of LCD panel (see below) |







Adjust brightness for LCD display with small screw on blue pod



7.0 Spare parts

| Part no. | Description | Images |
|------------------------------|---|---|
| Electrical Components | | |
| RK-010 | Rockwell front control panel |  |
| RK-E-SFCN | Superficial front control panel |  |
| RW-1030 | Rockwell 110/220V transformer |  |
| RW-010 | Rockwell / Superficial Rockwell loading motor |  |
| RW-011 | Rockwell load cell |  |
| 811-881 | PC-RS232 software cable |  |

| Part no. | Description | Images |
|------------------------------|---------------------------------|---|
| Electrical Components | | |
| 811-882 | PC RS-232 to USB software cable |  |
| MHT-E-PR1 | MHT Printer-1 |  |
| MHT-E-PR2 | MHT Printer-2 |  |
| CORD-110 | 110V USA power cord |  |
| CORD-220R | 220V round prong power cord |  |
| CORD-220F | 220V flat prong power cord |  |

| Part no. | Description | Images |
|------------------------------|---|---|
| Mechanical Components | | |
| RW-M-LAA | Rockwell loading adjustment arm |  |
| RW-S | Precision screw feed height adjustment unit for Rockwell testers |  |
| 811-531 | Rockwell / Superficial large anvil |  |
| 811-501 | Rockwell / Superficial small anvil |  |
| 811-511 | Rockwell / Superficial V-anvil |  |
| 811-521 | Rockwell / Superficial square table |  |
| 811-401 | Rockwell diamond indenter |  |

| Part no. | Description | Images |
|------------------------------|-------------------------------|---|
| Mecahnical Components | | |
| RW-M-SW1 | Rockwell/Superficial Weight 1 |  |
| RW-M-SW2 | Rockwell/Superficial Weight 2 |  |
| RW-M-SW3 | Rockwell/Superficial Weight 3 |  |
| RW-M-SW4 | Superficial Rockwell Weight 4 |  |
| RW-M-SW5 | Superficial Rockwell Weight 5 |  |
| RW-M-SW6 | Superficial Rockwell Weight 6 |  |
| RW-M-WSA | Weight suspending arm |  |

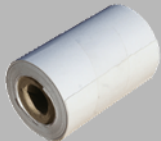
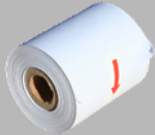
| Part no. | Description | Images |
|------------------|---|---|
| | Mecahnical Components | |
| RW-FEET | Rockwell feet (4/pkg) |  |
| 823-903 | Dust cover for Rockwell tester | |
| 811-100-1 | Printer paper rolls for MHT-1 printer (2.25-inch width) |  |
| 811-100-2 | Printer paper rolls for MHT-2 printer (1.75-inch width) |  |

8.0 Hardness Testing Basic

Hardness Testing provides useful information, which can be correlated to tensile strength, wear resistance, ductility, and other physical characteristics of the material. Hardness testing is therefore useful for monitoring quality control and for aiding in the materials selection process.

ROCKWELL HARDNESS

Rockwell hardness (HR) is an indentation hardness test that is determined with a spheroconical penetrator, or hard steel ball, that is forced into the specimen surface. The test is accomplished by bringing the specimen into contact with the penetrator and allowing the penetrator to be slowly forced into the specimen surface by a series of weights acting through a system of levers. After the load is released, a dial pointer or LED screen indicates the hardness number.

Typical Applications:

- Quality control for metal heat treatment
- Materials receiving inspection
- Evaluation of welds in steels and other metal alloys
- Failure analysis

Standard Rockwell testing is at 60, 100 and 150 kg loads and Superficial Rockwell testing is at 15, 30 and 45 kg loads.

BRINELL HARDNESS

To determine a Brinell hardness number (BHN), a 10 mm diameter steel ball is typically used as an indenter with a 3,000 kgf (29 kN) force. For softer materials, a smaller force is used; for harder materials, a tungsten carbide ball is used. The BHN can also be converted into the ultimate tensile strength (UTS), although the relationship is dependent on the material, and therefore is only an empirically based value.

VICKERS HARDNESS

The Vickers test is often easier to use than other hardness tests since the required calculations are independent of the size of the indenter, and the indenter can be used for all materials irrespective of hardness. The Vickers test can be used for all metals and has one of the widest scales among hardness tests. The unit of hardness given by the test is known as the Vickers Pyramid Number (HV) or Diamond Pyramid Hardness (DPH).

MICROHARDNESS

Microhardness testers are both mechanical and optical measuring tools. The indent is produced by applying a known load to the specimen and then measuring the size of the appropriate diagonals either optically or with image analysis software.

Microhardness is primarily determined with either a Knoop or Vickers indenter under test loads in the range of 1 to 2000 gram-force. Microhardness is used to measure the hardness of specific phases, small particles, and for brittle materials.

Knoop hardness (HK) number is based on the size of the indent that a rhombic-based, pyramidal diamond indenter produces under a known applied load. The HK number is calculated by dividing the applied load (kilogram-force) by the projected area of the indentation (square millimeters).

The Vickers hardness (HV) number is obtained by dividing the applied load in kilogram-force by the surface area of the indentation. The area of the indentation produced from the Vickers square-based pyramidal diamond is determined by the mean distance between the two diagonals of the indentation.

8.0 Appendix RS232 Connector

For Window XP HyperTerminal is already installed. If you are using WIN7 the program needs to be installed with the CD provided.

Also if your computer has an RS232 port use this port instead of the USB port. If you do not have an RS232 port you will need to install a conversion driver.

First determine which scenario fits your computer.

- A. Window XP with RS232 port (Step 4 only)
- B. Windows XP without RS232 port (need to install conversion programs - PL203_Prolific_DriverInstaller_v10518) (Step 1,2 and 4)
- C. Window WIN7 without RS232 port (need to install conversion programs - PL203_Prolific_DriverInstaller_v10518 and Hyperterm software) (Step 1,2,3)
- D. Window WIN7 with RS232 port (need to install Hyperterm) (Step 1 and 3).

STEP 1. Load Install Files to Desktop or other easy to find location and connect cable to tester and turn on

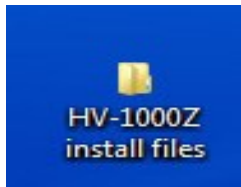

STEP 2. Computer does not have an RS232 port (need to adapt to USB port)

Use the following procedure:

- Open HV-1000Z Install File Folder

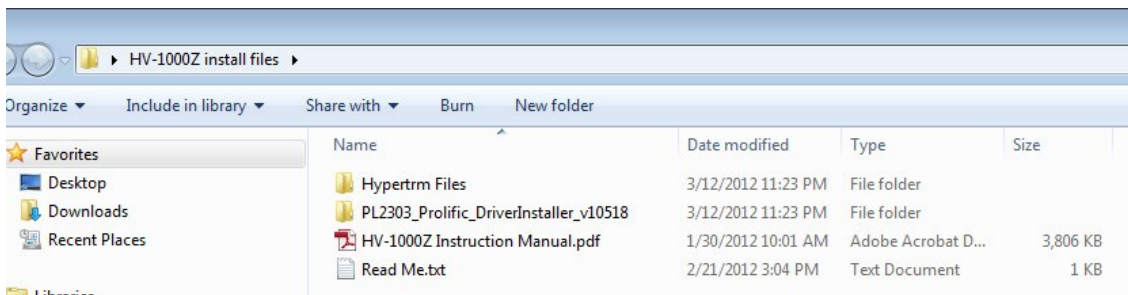

- Double click or open **PL2303_Prolific_DriverInstaller_v10518** file

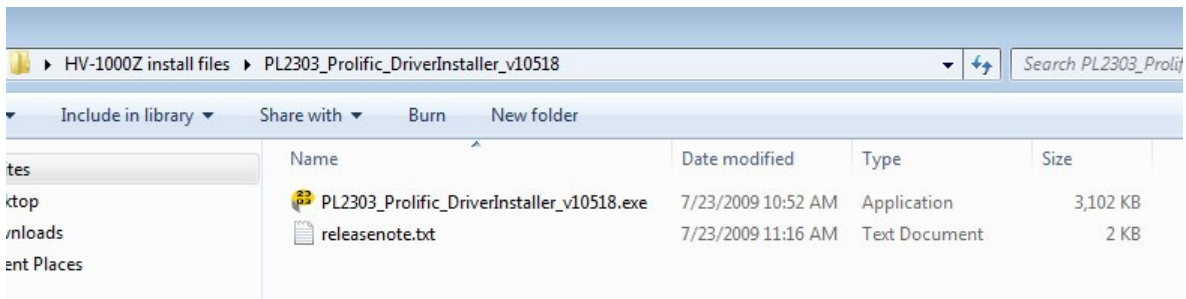

- Double click or run **PL2303_Prolific_DriverInstaller_v10518.exe**
-Follow installation procedure (Click on NEXT)

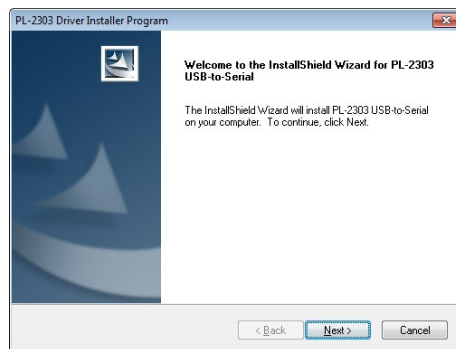

-After installation is complete (Click on FINISH) and restart computer.

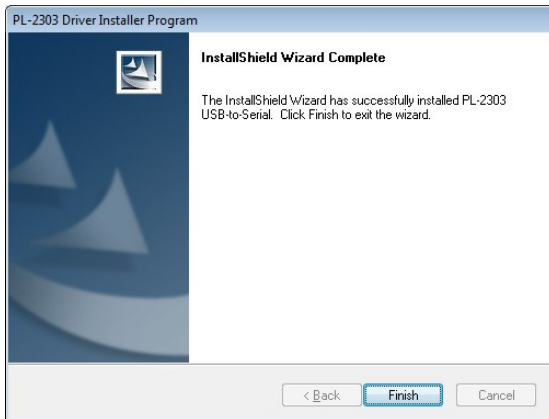

STEP 3. Computer uses WIN 7 and does not have Hyperterm installed.

- Double click to open HV-1000Z installation file

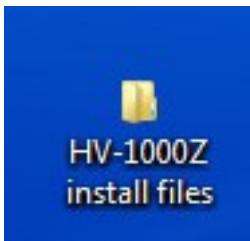

| Name | Date modified | Type | Size |
|----------------------|--------------------|--------------------|----------|
| Hyperterm Files | 3/12/2012 11:23 PM | File folder | |
| PL-2303 Driver Files | 3/12/2012 11:23 PM | File folder | |
| Hyperterm Files | 3/12/2012 10:01 AM | Adobe Acrobat D... | 3,806 KB |
| Readme | 3/12/2012 3:04 PM | Text Document | 1 KB |

Please read this instruction manual carefully and follow all installation, operating and safety guidelines.

- Double click or open Hyperterm Files folder
- Double click or Run hyperterm.exe

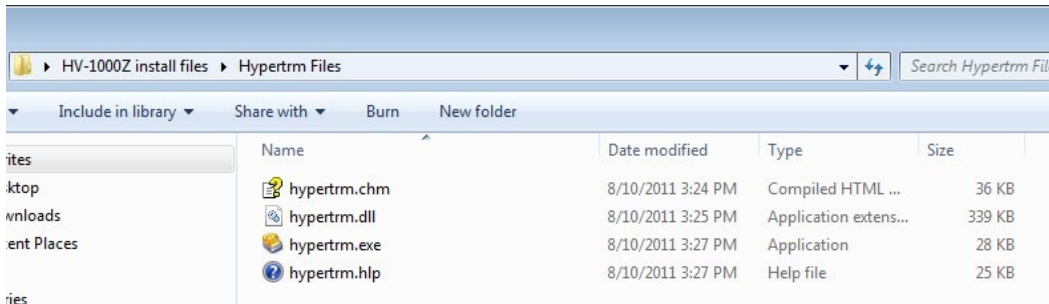

- Answer NO to question

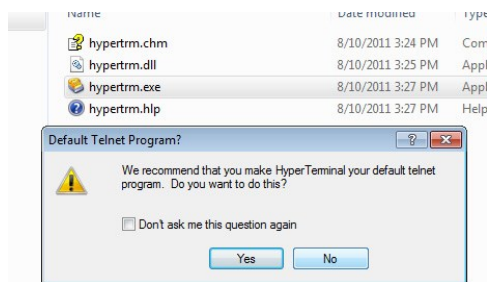

- Name: Input RS232. Click OK

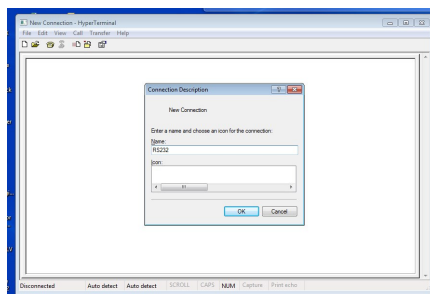

- If hardness tester was on and connect the correct COM port should be selected. Click OK. Note if connect using TCP/IP (Winsock) is displayed the computer was not rebooted after adding RS232 to USB conversion and needs to be rebooted.

-Change the Bits per seconds to 9600. Click OK

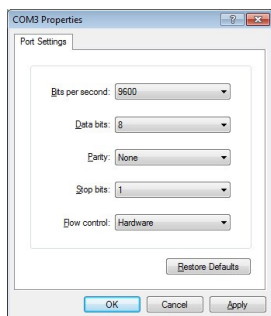

-HyperTerminal will now be available to accept the data by pressing PRT

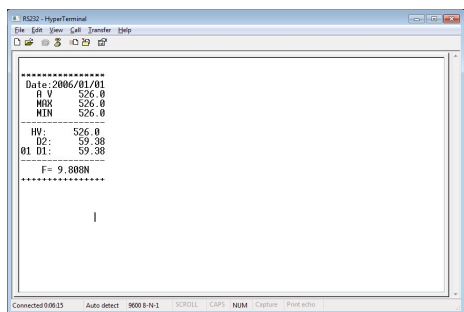

-NOTE: FOR WIN7 if you turn off computer or close the HyperTerminal connection you will need to do the following to access the program the next time you use it (A bit inconvenient, however this is because Microsoft does not support this 3rd party software anymore).

1. Open Hyperterm Folder (on Desktop if saved there during installation_
2. Double click on Hyperterm.exe
 - Choose NO
 - Cancel or "X" out of window.
3. File > Open > Select RS232.ht file (if using same USB port as it was installed on)

STEP 4. To set-up with Windows XP

-Click → Start, ALL Programs → Accessories → Communications → Hypertrm

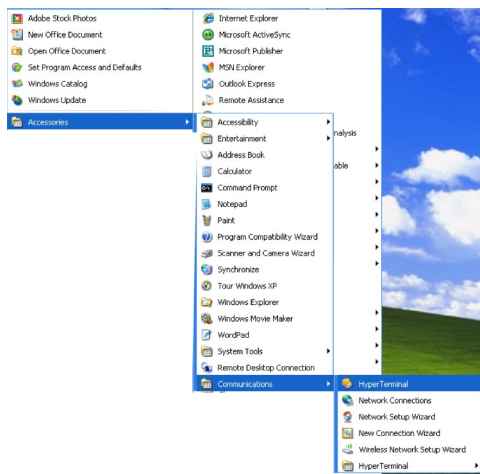

-In the new connection box, enter “RS232” in the Name field and click OK



-In the Connect To dialogue box choose the

appropriate COM port from the Connect using drop down box, Click OK



-In the Port Properties dialogue box, select 9600 for Baud rate, and leave the other parameters unchanged, Click Apply, OK and HyperTerminal will be connected to the tester.

