



HVAC System Air Leakage

2019

Presented By:

Mark Terzigni

Director of Engineering

Technical Services

SMACNA



Learning Objectives

- Understand the difference between “System” leakage and “Duct” leakage
- Understand what information is required to properly specify system leakage tests
- Understand what various codes and standards require for duct air leakage testing
- Understand misconceptions related to leakage testing



What is “Duct Leakage”

- Duct leakage is the leakage of air from **DUCT**
- Equipment leakage is the leakage of air from **EQUIPMENT**
- Accessory leakage is the leakage of air from **ACCESSORIES**



System Leakage

- HVAC Air System Leakage is the **combination** of duct, equipment and accessory leakage.
- **DUCT leakage is not SYSTEM leakage**



Energy Impacts

- Not all air leaks have the same impact on energy
- Leaks on the return can introduce “raw” air
- Supply leaks, especially into unconditioned space reduce the amount conditioned air impacting indoor environmental comfort
- Supply leaks into conditioned space do deliver the “energy” but not to the intended area
- Because the impacts are different it is impossible to directly relate a CFM of leakage to a specific energy loss.



Is Testing Justified?

- Many people agree that testing at least a portion of the ductwork is justified.
- How much should you test?
- What sections of duct should you test?



How much to test?

- The majority of energy codes/standards require 25% of the “high-pressure” duct to be tested...
- **ASHRAE 90.1 2010/13/16**
 - **6.4.4.2.2 Duct Leakage Tests.** Ductwork that is designed to operate at static pressures in excess of 3 in. w.c. and **all ductwork located outdoors** shall be leak-tested according to industry-accepted test procedures (see Informative Appendix E). Representative sections totaling **no less than 25%** of the total installed duct area for the designated pressure class shall be tested. All sections shall be selected by the building owner or the designated representative of the building owner. Positive pressure leakage testing is acceptable for negative pressure ductwork.



How much to test?

- **IECC 2012/2015/2018:**
 - **503.2.7.1.3** High-pressure duct systems. ...shall be leak tested in accordance with the SMACNA *HVAC Air Duct Leakage Test Manual*... Documentation shall be furnished by the designer demonstrating that representative sections totaling **at least 25 percent** of the duct area have been tested...



How much to test?

- Some believe that 100% testing is required, and it is the only way “to be sure” ...
- Perhaps a more practical approach is the 25-50-100 approach...



How much to test?

- Currently proposed language would require duct (not system) leakage testing in the base mechanical code for California.
- The latest proposal requires at least 10% of the duct (by surface area) be tested.
- Additional testing is required if initial testing indicates issues with performance.



What about “low-pressure” duct?

- This is where discretion must be used.
- “...low pressure duct leaks more than high pressure duct...”
 - This statement is true if the duct is tested at the same pressure, especially in older buildings where the seal class varied by pressure class.



What about “low-pressure” duct?

- As seal class “A” becomes the norm the difference in leakage (at the same pressure) will likely decrease or perhaps disappear altogether. So under operating conditions the potential leakage for the low pressure side would be lower because the operating pressure would be lower



What about “low-pressure” duct?

- Leakage is also a function of the “size of the hole” which means it is a function of the amount of duct used.
- If the majority of duct is low pressure it may be justified to test some of it.
- USE 25-50-100 (10-20-100)



Code Update

- IAPMO Green Plumbing and Mechanical Code Supplement
- Duct Leakage Tests. Ductwork ~~that is designed to operate at static pressures in excess of 3 inches Water Column (0.75 kPa)~~ and all ductwork located outdoors shall be leak-tested according to the ANSI/SMACNA HVAC Air Duct Leakage Test Manual. Representative sections totaling no less than ~~25~~ 20% percent of the total installed duct area ~~for that designated pressure class~~ shall be tested. Should the tested 20% fail to meet the requirements of this section, then 40% of the total installed duct area shall be tested. Should the tested 40% fail to meet the requirements of this section, then 100% of the total installed duct area shall be tested. All sections shall be selected by the building owner or the designated representative of the building owner. Positive pressure leakage testing is acceptable for negative pressure ductwork. The maximum permitted duct leakage shall be:



Code Update

- IAPMO Uniform Mechanical Code
- Duct Leakage Tests. Ductwork ~~that is designed to operate at static pressures in excess of 3 inches Water Column (0.75 kPa)~~ and all ductwork located outdoors shall be leak-tested according to the ANSI/SMACNA HVAC Air Duct Leakage Test Manual. Representative sections totaling no less than ~~25~~ 10% percent of the total installed duct area ~~for that designated pressure class~~ shall be tested. Should the tested 20% fail to meet the requirements of this section, then 40% of the total installed duct area shall be tested. Should the tested 40% fail to meet the requirements of this section, then 100% of the total installed duct area shall be tested. All sections shall be selected by the building owner or the designated representative of the building owner. Positive pressure leakage testing is acceptable for negative pressure ductwork. The maximum permitted duct leakage shall be:



Other standards

- Traditionally duct operating “in excess” of 3 in. wg was tested.
- Current proposals include 3 in. wg
- Some make all duct fair game.
 - CMC no limit on pressure
 - 10% minimum proposed
 - CEC no limit on pressure
 - 25% minimum proposed



Duct or System Testing?

- To this point all of the codes and “used” energy standards only require duct testing
- None specifically require true system testing
 - Some residential address the “system” but still call it “duct” leakage
 - The pass/fail criteria used are arbitrary
- All Commercial versions use SMACNA’s approach for duct leakage pass/fail for commercial duct.
- Concept works for residential as well



Why not use a % to fan flow?

- Leakage is a function of pressure
- And the “size of the hole”

$$F = C_L P^N$$

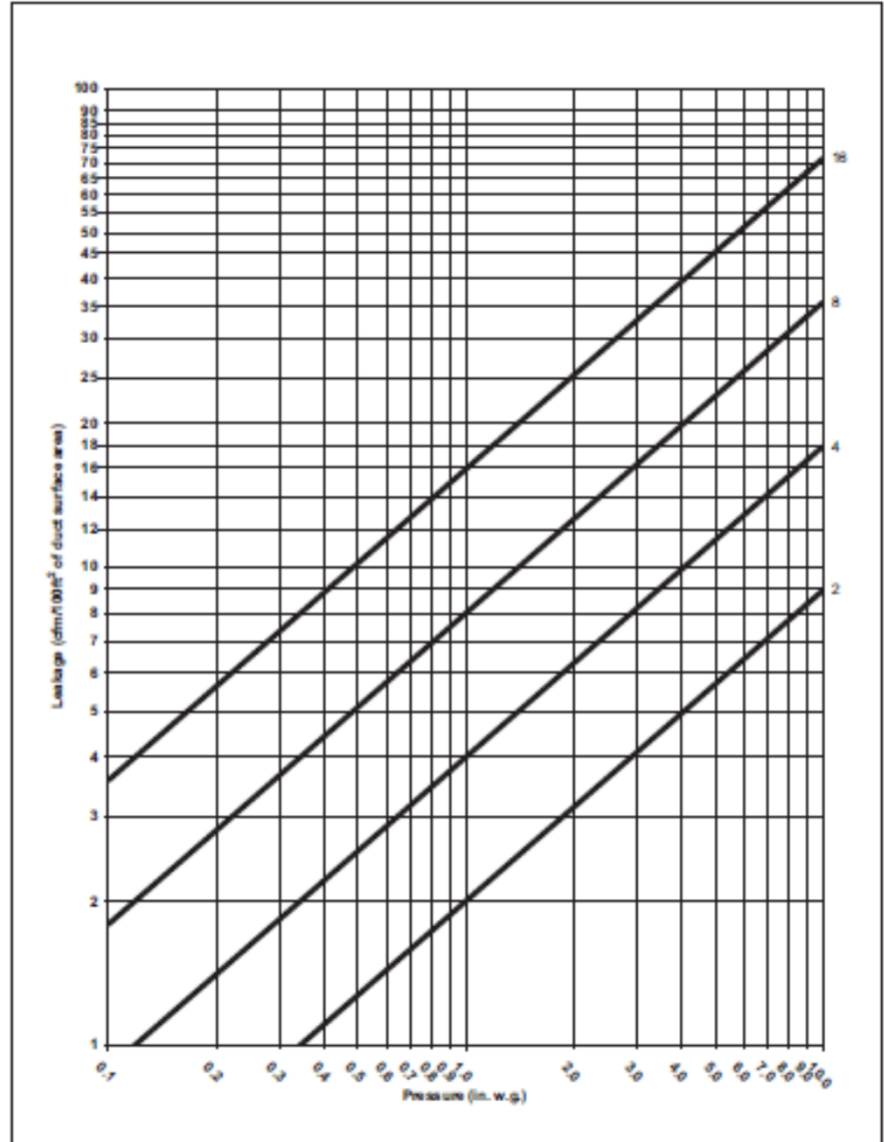
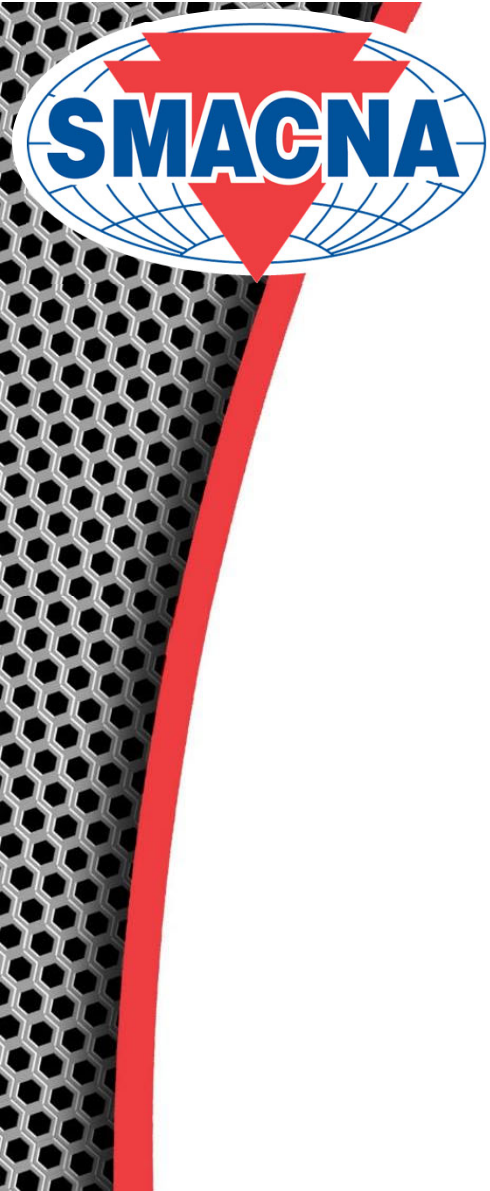



Why not use a % to fan flow?

- As mentioned earlier Leakage is a function of pressure, and it is a function of “the size of the hole”
- Leakage is not a function of the volume of air
- Leakage is not a function conditioned floor space



Why not use a % to fan flow?

- ASHRAE RP 1292

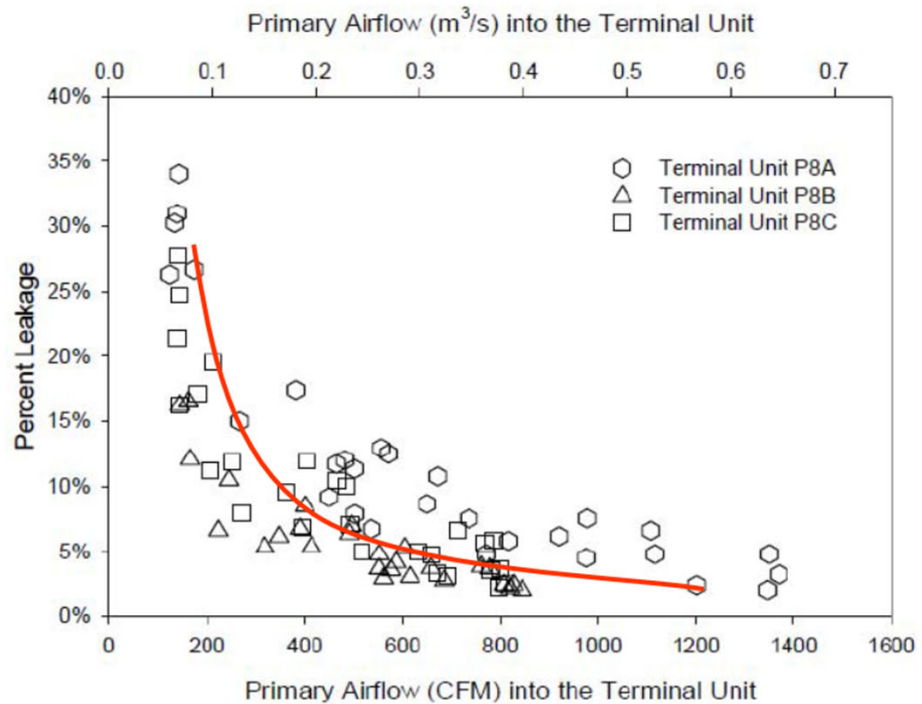

Figure 5-10 – Percentage Air leakage for three 8 inch parallel terminal units.



Why not use a % to fan flow?

Figure 5-10 shows a plot of the **percentage leakage as a function of the supply airflow** from the eight inch terminal units. **In general, the percent of leakage ($Q_{leakage}$ divided by $Q_{primary}$) increased as the primary airflow decreased.**



Why not use a % to fan flow?

- Put simply as the “fan flow” decreased the percentage of leakage increased...
- This is likely because the leakage itself stayed nearly constant because the test pressure was the same.



Why not use a % to fan flow

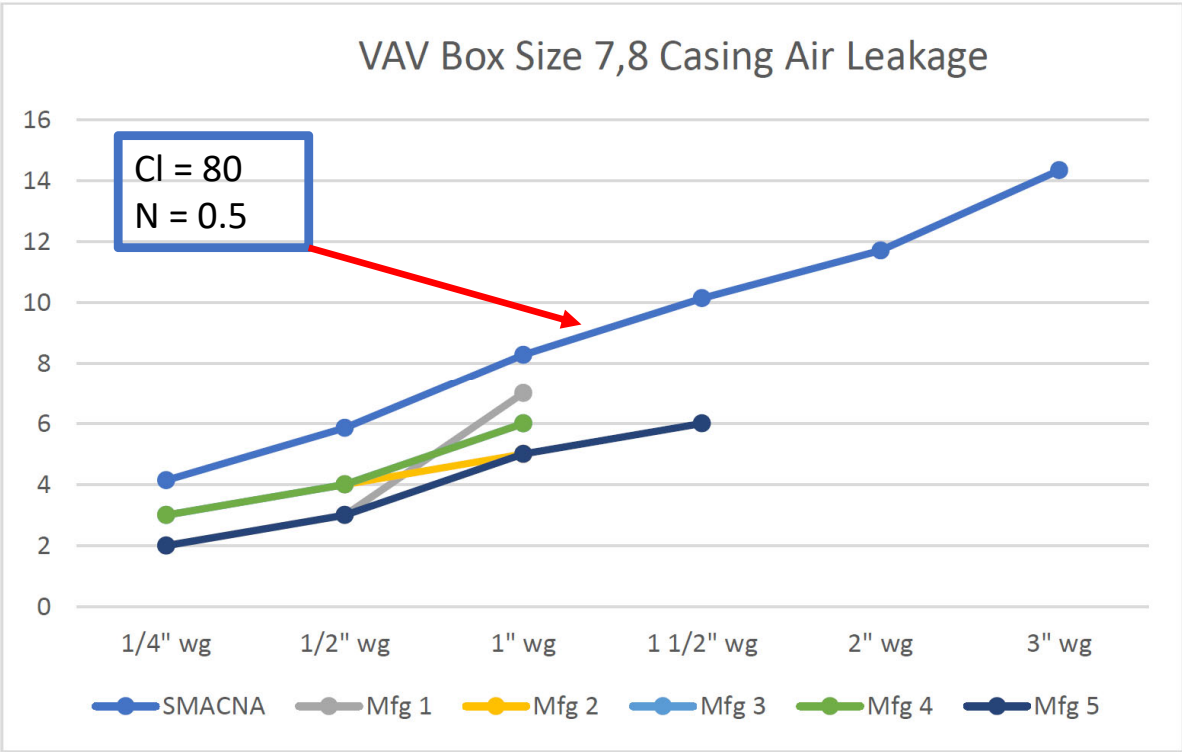



Why not use a % to fan flow?

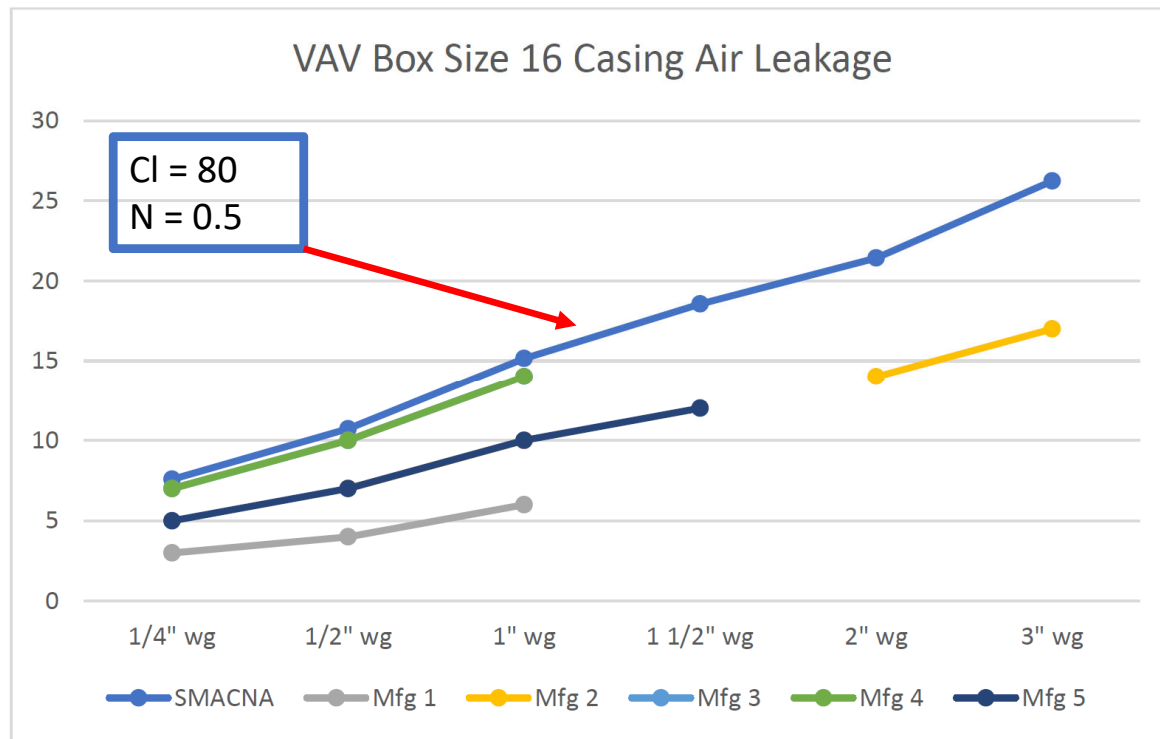



Why not use % to fan flow?

- Originally we (SMACNA) could not get nice curves for VAV boxes
 - We tried to get leakage for the whole box to fit a curve
 - Turned out the data worked once we treated a VAV box as a “box” and a “damper”
 - Damper leakage was a constant at a given pressure
 - Not a function of surface area
 - The “box” does leak as a function of surface area and pressure



Why not use a % to fan flow?

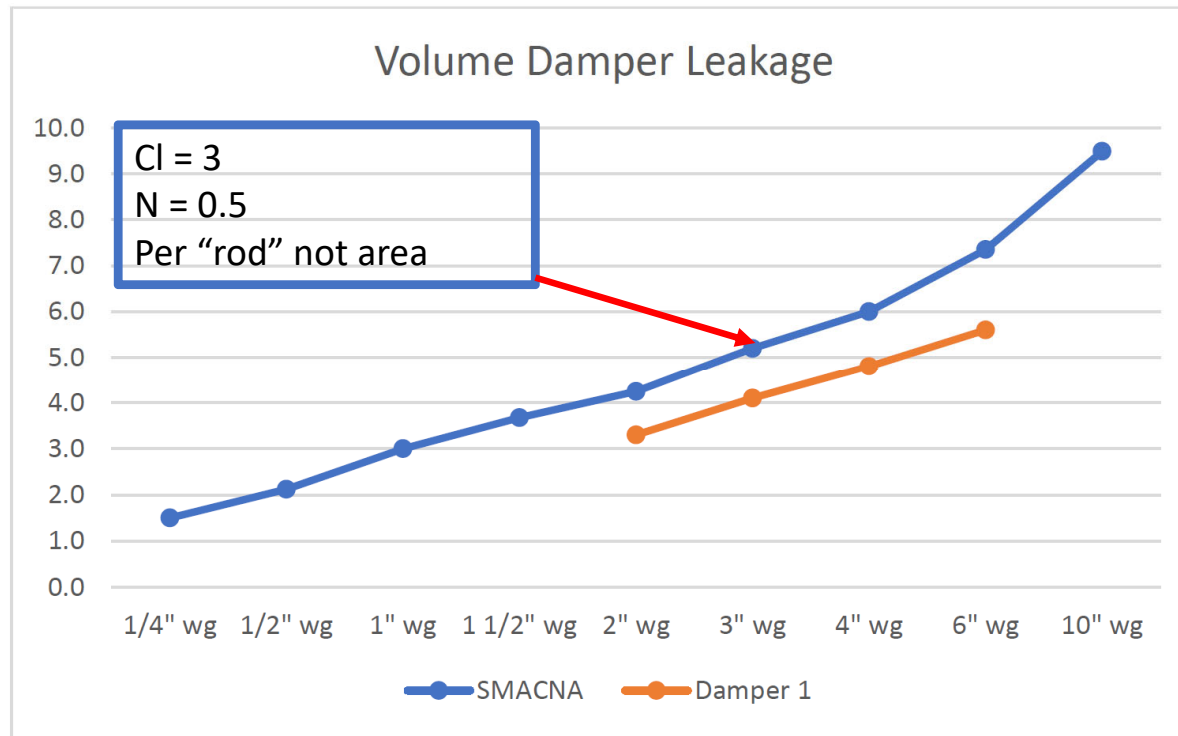



Why not use a % to fan flow?

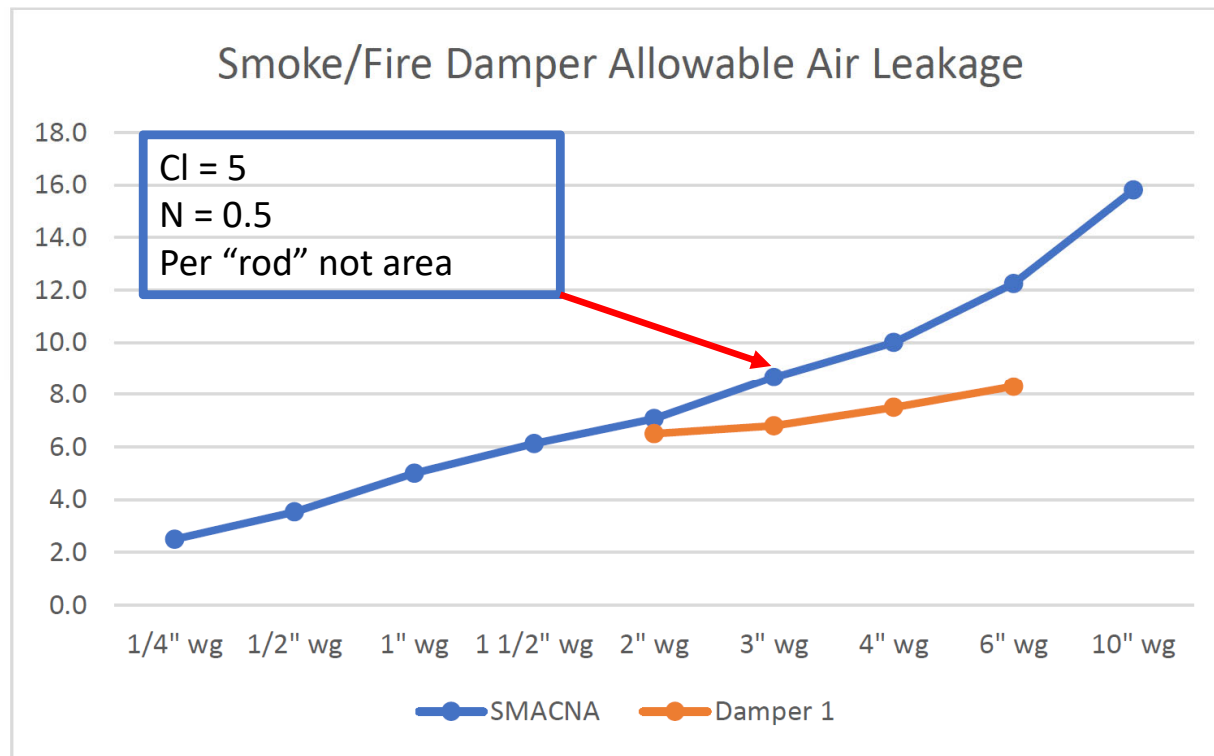



Control Rod for Fire Damper

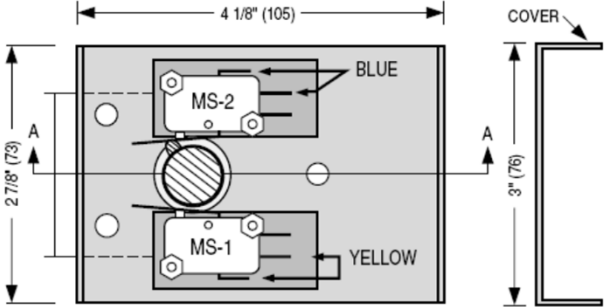

EXTERNAL RIGHT HAND MOUNTING: FRONT VIEW (LESS COVER)

Do NOT apply sealant at these locations

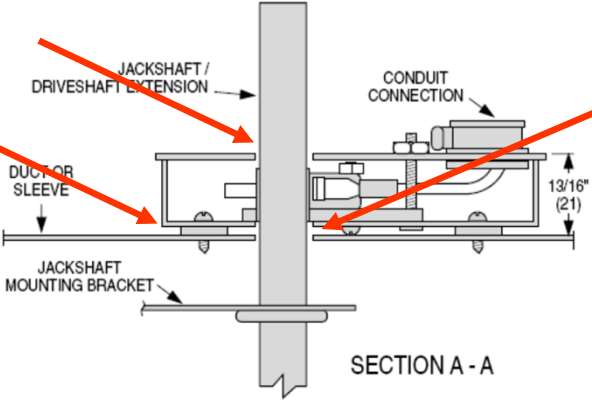



Real Issue to Avoid

- When arbitrary requirements for pass/fail are used and are also misapplied the contractor is forced to decide what to comply with.
- What happens when a spec differs from codes/standards/warranties/listings (UL)?
- The SMACNA standard will require designers to “prove” a system was designed to meet the performance specs.



Why not use a % to fan flow?

- ALL of the codes/standards mentioned earlier use a leakage class for duct, not a percent.
- 90.1 class 4 all duct
- IECC class 4 all duct
- IAPMO GPMCS class 4 all duct



Why not use a % to fan flow?

- ASHRAE RP 1292

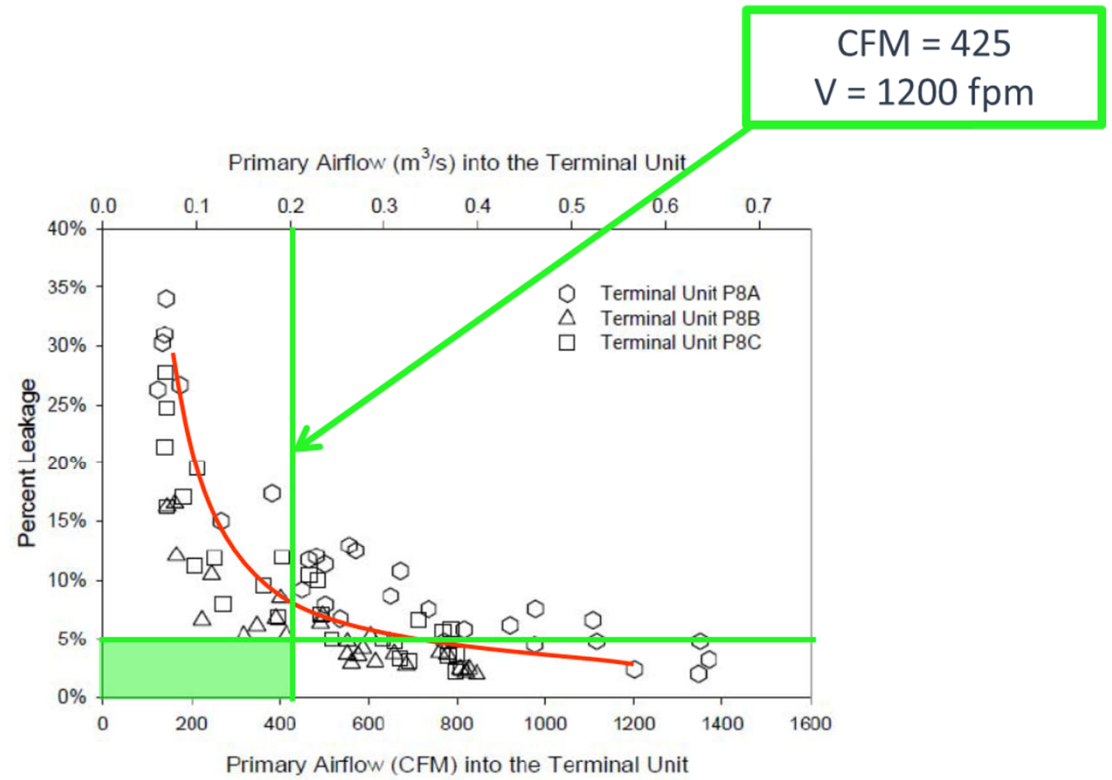

Figure 5-10 – Percentage Air leakage for three 8 inch parallel terminal units.



Active Tests vs Static Tests

- Active test – test performed on a completed functioning system
- This method would measure the actual leakage at a given point in time for the system under the operating conditions at that time.
- This method is good for research studies and for attempts to correlate energy use to leakage
 - Remember though that not all leaks have the same impact



Active Tests vs Static Tests

- Static Test – current approach used for duct testing
- Allows for testing of incomplete systems
- Is a consistent basis of comparison
 - Test conditions (pressure) are defined and not system dependent – test pressure not to exceed capacity



Where can we get info on equipment or accessories?

- The industry currently has several sources for designers to use to get info on leakage for equipment and accessories. There are still gaps, and the industry is working to close them.



Equipment Leakage Test

- **ASHRAE Standard 193 authorized September 30, 2006.
Method of Testing for Determining the Air-Leakage Rate of HVAC Equipment**
- **Published mid-summer 2010.**
- **1. PURPOSE:**
 - **This standard prescribes a method of testing to determine the air-leakage rate of forced-air heating, and cooling HVAC equipment, prior to field installation.**



Equipment Leakage Test

- **2. SCOPE:**
 - **2.1 This standard applies to the following:**
 - a) Equipment intended for installation in ducted systems, including furnaces, heat pumps, air conditioners, coil boxes, filter boxes, and associated components.
 - b) Equipment that moves less than 3000 cfm (1400 L/S) of air.
 - **2.2 It does not apply to field installed components, such as plenums or ducts.**
 - **NOTE no PASS/FAIL criteria and does not apply to VAV boxes**



Equipment Leakage Data

- ASHRAE RP 1292
- Was not the intent to evaluate leakage
- Turned out that leakage was considerable

- Leakage rates for boxes were 5%-30%...That's right, the best boxes still hit 5% and those rates are at non-typical operating conditions ie 1200 cfm for and 8 in.box ($v \sim 3400$ fpm)



Equipment Leakage

- AHRI Standard 1350
 - Provides for casing leakage data
 - Uses surface area
 - Uses leakage class
 - Uses N of 0.65



Accessory Leakage

- Data virtually non-existent except for single duct VAV boxes
- Some data that exists is not applicable
- Most data on dampers – Volume/Smoke etc. measure the leakage across the damper when the damper is closed.
- Does not measure leakage from “inside” the system to “outside” the system



Fill the Gaps

- What to do if data does not exist
 - Skip testing unknown items
 - The SMACNA System Air Leakage Test Standard allows for field evaluation of items to determine leakage rates.
 - Basically you isolate the item, verify the installation, test it for leakage.



Isolated test

- Not required but encouraged to test item at 3 pressures to develop a curve
- Must be able to determine leakage at the desired test pressure
- This method can also be used to challenge leakage allowances of “known” items
- Any party can use this approach to either raise or lower allowable leakage



Issues to Avoid

- Items are to be installed per manufacturer's instructions/listing requirements
- Do not modify portions of the system for testing, the system should be as close to "as installed" as possible
- Testing equipment may not be finite enough to measure difference in low leakage items – may need to test multiple items at once and average



Issues to Avoid

- Be careful to account for every component.
- VAV box is a good example
 - Also has a damper
 - May have coils, filters, electric reheat, etc.
 - Each of those items impact leakage rates



Quote from Manufacturer

“It is extremely important to specify and order the correct product. Field repairs or modifications almost always result in a loss of UL certification. If repairs or modifications are required, the AHJ must be consulted.”



Why not use a “system” value

- If we are going to test a “system” we need to verify that “specification” meets “expectation”
- If the system fails a test we need to be able to determine where the deficiency is
- We need to stop assuming a value and then forcing contractors to make those assumptions correct – we can do better than that
- Why go through the expense to test a temporarily modified system?



“CHAIN of RESPONSIBILITY”

- The first link in the chain is the DESIGNER
 - How a system performs is dependent on how it was designed
- MANUFACTURERS
 - They must provide equipment that performs as “advertised”
- FABRICATOR/INSTALLERS/CONTRACTORS
 - They must fabricate and install items correctly
- Code Bodies
 - Must enforce codes consistently and correctly



Misconceptions

- The cost associated with testing the duct system is basically the time and material to perform the test.
- Not true...Often the largest expense associated with testing is the disruption to workflow or job schedule in addition to the time and materials to perform the test.



Misconceptions

- The leakage rate determined through testing (SMACNA, ASHRAE) is the actual leakage under operating conditions
 - Test pressures do not typically match operating pressures
 - Conditions vary in modern systems



Misconceptions

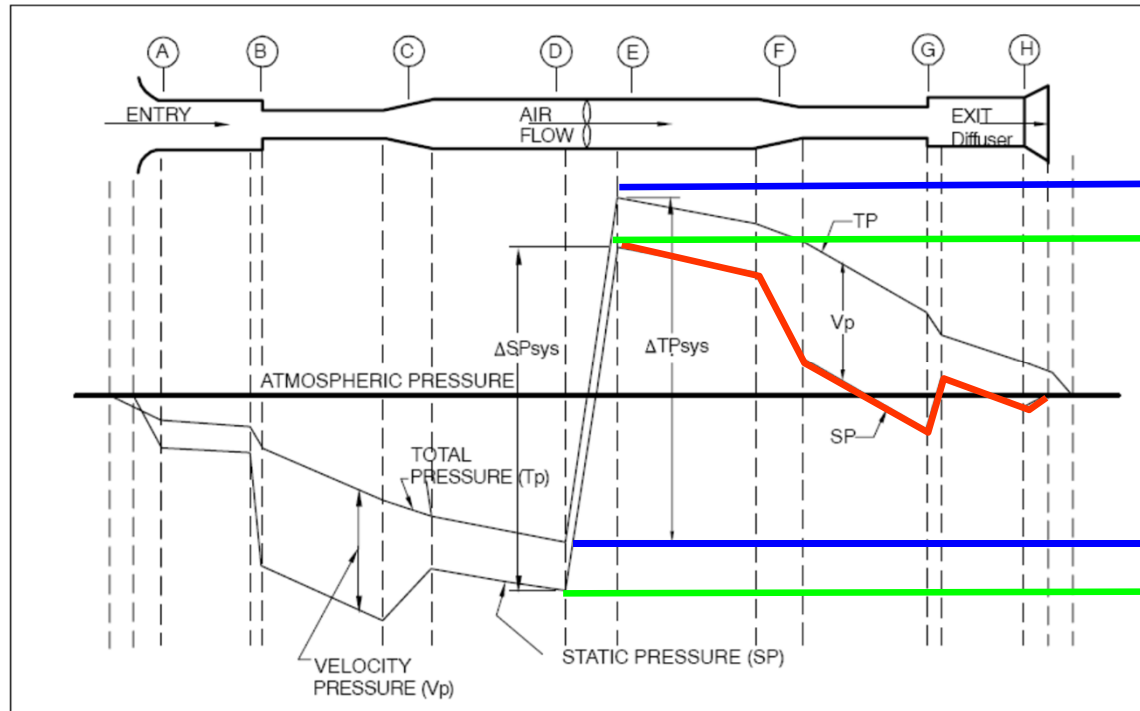



Air Leakage Misconceptions

- Mean pressure:
 - Standards in Europe utilize the concept of mean pressure for duct testing.
 - Example: The “high pressure” portion of a duct system requires 4 in. w.g. at the fan but only 2 in. w.g. at the VAV boxes. The test pressure would be 3 in. w.g. $[(4+2)/2 = 3]$
 - The goal is to make test conditions closer to operating conditions.



Air Leakage Misconceptions

- Real life example...
 - Down Stream of VAV box
 - Spec's required duct fabricated to 2 in. w.g.
 - Engineer wanted leakage testing done at 4 in. w.g.
 - Engineer wanted testing through flex to diffuser
 - Max 2% leakage allowed (9.2 CFM)
- Typical downstream section
 - 10' of 12 x 10 rect. Duct 12' of 9" round duct
 - 1 lo-loss tap, and 1 90° elbow
 - 2 outlets (230 CFM each), 5' flex on each



Air Leakage Misconceptions

- Let's assume all leakage is from the rigid duct
 - Total rigid duct surface area 65 ft²
 - 9.2 CFM/65 ft² x 100 = 14 cfm/100 ft² = F
 - $C_L = F/P^{0.65} = 14/4^{0.65} = 5.7 \sim 6$
 - Is this attainable? Yes and No...
 - Yes, for the rigid duct in this example an average leakage class of 6 is attainable, but not expected using the code compliant practices at the time.
 - Seal Class A and other construction options can achieve this leakage class, but there is a cost associated with this...



Air Leakage Misconceptions

- What happens if we tested this at 2 in. w.g.?
- Per the first edition of the leakage manual the “average” leakage class for the rigid duct is 19.
- This would permit a pass if the rigid duct leaked 19 CFM or less at 2 in. w.g. S.P.
- Does that mean the rigid duct would leak 4%?
- Yes and No
 - Yes, under these test conditions it would leak about 4%
 - No, this leakage is not the same as leakage under operating conditions.



Air Leakage Misconceptions

- Reality check...
 - Analysis of the system shows that it would operate 0.1 to 0.13 in. w.g.(From VAV to diffuser)
 - Includes rigid duct loss, fitting loss, flex duct loss (@15% compression), and max static pressure for diffusers)
 - Even at a leakage class of 48 (unsealed duct) at the maximum expected operating pressure (.13 in. w.g.) the rigid duct would leak about 8 CFM or 1.8%
This is less than the 2% or 9.2 CFM allowed by spec.
 - Remember the mean pressure theory?



Air Leakage Misconceptions

- Reality check...
 - Now, if we use the actual leakage class for the rigid duct (round and rect. combined) CL = 19 @ the expected average operating pressure 0.065 in wg
 - The actual leakage would be closer to 2 CFM or 0.4% leakage under operating conditions.
- What else does this illustrate?
 - Leakage testing for low pressure systems is not a good use of time/money/effort.
 - Looking at actual operating conditions your maximum benefit for this example is 3 CFM (0.65%). That is assuming the duct goes from unsealed to sealed



Good Practices

- Test some of the system early on in the construction process
 - It will make sure that all parties involved understand what is expected
 - It will identify any potential issues early which makes them easier and less expensive to fix



Good Practices

- Write a good specification
 - Detail how much duct/system is to be tested
 - 25-50-100
 - Provide a “correct” pass/fail criterion
 - AVOID arbitrary values such as **X%**
 - Use available data from research
 - Specify seal class “A” for duct
 - NEVER SPECIFY TEST PRESSURES GREATER THAN THE CONSTRUCTION CLASS



Summary

- Testing 100% of the system is rarely justified
- Testing ductwork does not reduce leakage
 - Sealing ductwork reduces leakage
- Account for all items being tested
 - Make sure data applies to test conditions
- There is no consensus based method to determine a correct pass/fail criteria for the system – yet...