



This manual contains important warnings and information.
READ AND KEEP FOR REFERENCE.

INSTRUCTIONS

US Patent Pending

HVLP—Turbine Guns

10 psi (0.07 MPa, .7 bar) Maximum Inlet Air Pressure

50 psi (0.35 MPa, 3.5 bar) Maximum Inlet Fluid Pressure

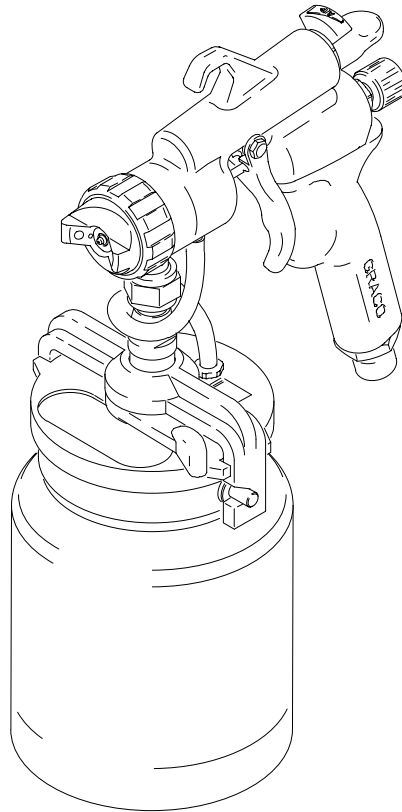

Cup Feed

Includes 1-quart (1 liter) cup

Model 244113, without fluid set

Model 244117, with # 3 fluid set

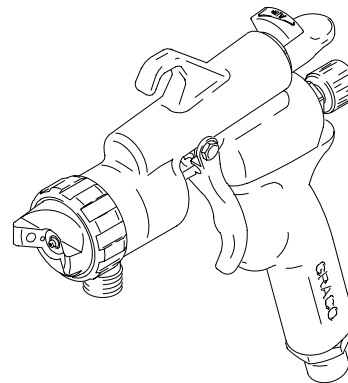

T10746

Remote Pressure Feed

Model 244115, without fluid set

Model 244118, with # 3 fluid set

GRACO INC. P.O. BOX 1441 MINNEAPOLIS, MN 55440-1441

©COPYRIGHT 2000, GRACO INC.

Graco Inc. is registered to I.S. EN ISO 9001

Table of Contents

Warnings	2
Introduction	4
Spraying Techniques	12
Maintenance	14
Service	17
Troubleshooting	19
Accessories	21
Technical Data	21
Parts	23
Graco Standard Warranty	24
Graco Phone Number	24

Symbols

Warning Symbol



This symbol alerts you to the possibility of serious injury or death if you do not follow the instructions.

Caution Symbol



This symbol alerts you to the possibility of damage to or destruction of equipment if you do not follow the instructions.

WARNING



FIRE AND EXPLOSION HAZARD

Improper grounding, poor ventilation, open flames or sparks can cause a hazardous condition and result in a fire or explosion and serious injury.

- Ground the equipment.
- If there is any static sparking or you feel an electric shock while using this equipment, **stop spraying immediately**. Do not use the equipment until you identify and correct the problem.
- Provide fresh air ventilation to avoid the buildup of flammable fumes from solvents or the fluid being sprayed.
- When flammable liquid is sprayed or used for flushing or cleaning the equipment, the turbine must be placed at least 20 feet (6.1 m) away from areas where hazardous concentrations of flammable vapors are likely to occur.
- Use additional air hose if necessary to ensure that the turbine is operated in a clean, dry, well ventilated area.
- Never place the turbine inside a spray booth! Use this equipment outdoors or in extremely well ventilated areas.
- Keep the spray area free of debris, including solvent, rags, and gasoline.
- Electrically disconnect all equipment in the spray area.
- Extinguish all open flames or pilot lights in the spray area.
- Do not smoke in the spray area.
- Do not turn on or off any light switch in the spray area while operating or if fumes are present.
- Do not operate a gasoline engine in the spray area.

WARNING



INSTRUCTIONS

EQUIPMENT MISUSE HAZARD

Equipment misuse can cause the equipment to rupture or malfunction and result in serious injury.

- This equipment is for professional use only.
- Read all instruction manuals, tags, and labels before operating the equipment.
- Use the equipment only for its intended purpose. If you are not sure, call your distributor.
- Do not alter or modify this equipment. Use only genuine Graco parts and accessories.
- Check equipment daily. Repair or replace worn or damaged parts immediately.
- Do not exceed the maximum working pressure of the lowest rated system component. See the **Technical Data** on page 21.
- Use fluids and solvents that are compatible with the equipment wetted parts. Refer to the **Technical Data** on page 21 for wetted parts.
- Do not use hoses to pull equipment.
- Route hoses away from traffic areas, sharp edges, moving parts, and hot surfaces. Do not expose Graco hoses to temperatures above 82°C (180°F) or below -40°C (-40°F).
- Wear hearing protection when operating this equipment.
- Do not lift pressurized equipment.
- Comply with all applicable local, state, and national fire, electrical, and safety regulations.
- Do not point the gun at anyone or at any part of the body.
- Follow the **Pressure Relief Procedure** on page 11 if the fluid nozzle clogs and before cleaning, checking or servicing the equipment.
- Tighten all fluid connections before operating the equipment.
- Check the hoses, tubes, and couplings daily. Replace worn or damaged parts immediately.



TOXIC FLUID HAZARD

Hazardous fluid or toxic fumes can cause serious injury or death if splashed in the eyes or on the skin, inhaled, or swallowed.

- Know the specific hazards of the fluid you are using.
- Store hazardous fluid in an approved container. Dispose of hazardous fluid according to all local, state and national guidelines.
- Always wear protective eyewear, gloves, clothing and respirator as recommended by the fluid and solvent manufacturer.
- Do not use 1,1,1-trichloroethane, methylene chloride, other halogenated hydrocarbon solvents or fluids containing such solvents in the turbine spray system, which contains aluminum and/or galvanized-coated parts. Such use could result in a serious chemical reaction, with the possibility of explosion, which could cause death, serious injury, and/or substantial property damage.

Introduction

Features

The Graco HVLP-Turbine Gun features a quick-change fluid set, EasyGlide™ trigger and easy-access controls. One air cap fits all six fluid sets.

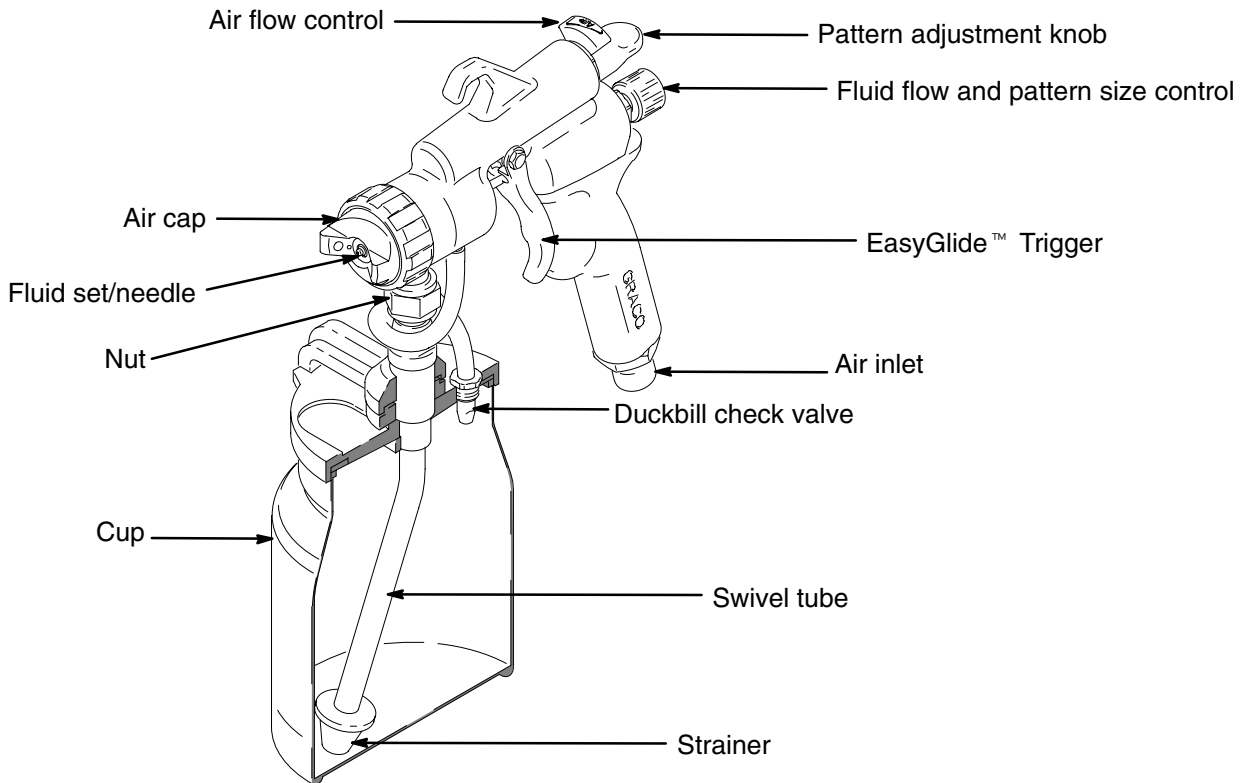

Fig. 1

General Operating Instructions

1. Setup the gun:
 - a. Adjust the fluid supply (page 5).
 - b. Establish the correct air flow (page 5).
 - c. Select the spray pattern and shape (page 6).
 - d. Select a fluid set (page 7).
2. Prepare the fluid and surface (page 9).
3. Connect the gun to the fluid and air supplies (page 10).
4. Fill the cup or remote pressure pot with fluid you will be spraying (page 11).
5. Spray (page 12).
6. Clean the gun following the clean-up instructions (page 14).

Setup

Fluid Flow

1. To obtain maximum fluid flow, turn fluid adjustment knob (21) counterclockwise until the trigger (10) moves freely. See Fig. 2.

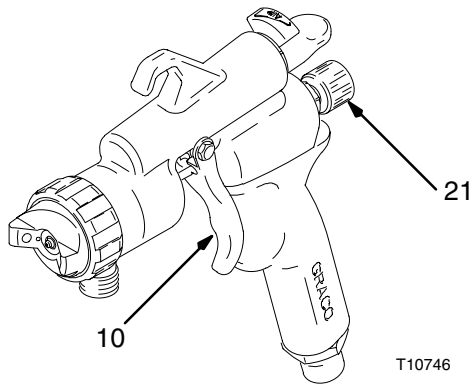

Fig. 2

2. For remote pressure pot, hold gun parallel to floor and adjust fluid pressure at 8 to 10 inch (203 to 254 mm) fluid stream. See Fig. 3.

For 2-quart remote pressure pot:
Set at 4 to 6 psi (0.28 to 0.42 bar).

For 2¹/₂-gallon remote pressure pot:
Set at 8 to 10 psi (0.56 to 0.70 bar).

NOTE: Heavier fluids or longer fluid hoses require greater pressures.

⚠ WARNING

Over-pressurizing the accessory remote pressure pots can cause serious injury. To reduce the risk, never exceed 50 psi (0.35 MPa, 3.5 bar) Maximum Inlet Fluid Pressure.

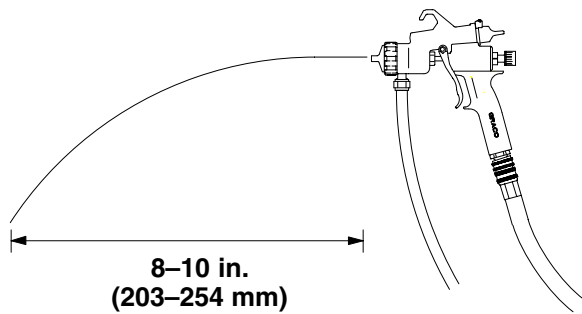

Fig. 3

3. If further gun fluid adjustment is needed, turn fluid adjustment knob (21) clockwise to reduce volume of fluid output. See Fig. 4.

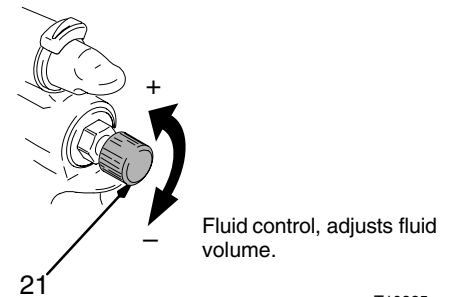

Fig. 4

⚠ CAUTION

Restricting the trigger and fluid needle travel by continuously spraying with the fluid adjustment knob closed (*turned clockwise*), will cause accelerated abrasive wear on the fluid needle and wear on the trigger.

For best results, adjust fluid flow at the pressure source or use a different size needle/nozzle/air cap combination.

Air Flow

4. Test spray pattern and atomization while holding gun about 6 to 8 inches (150 to 200 mm) from test piece.
5. Air Control Valve (B) on end of the gun controls both atomizing air and pressure in spray gun cup. See Fig. 5. Adjust air control valve as needed.

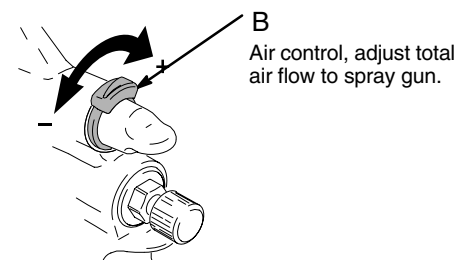

Fig. 5

Setup

NOTES:

- Control over-spray mist by using only as much air as necessary to spray fluid. Lighter fluids require less air.
- If atomization is still unacceptable, fluids may be thinned further or a different fluid set may be required. Refer to page 8 to determine fluid set or page 9 to prepare fluid.

Spray Pattern Direction and Shape

The spray pattern and direction are determined by the pattern selection knob (A) fluid adjustment knob (21) and air cap (15) positions. See Fig. 6.

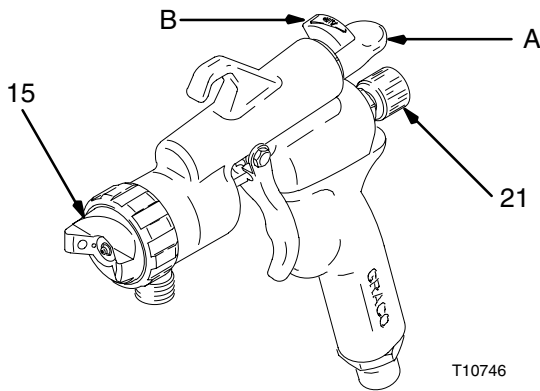

Fig. 6

Selecting the Pattern Shape

The Pattern Selection Knob (A) determines the shape of the spray pattern. To create a round spray pattern, set the pattern selection knob (A) to RND. To create a fan pattern, set the pattern selection knob (A) to FAN. Refer to Fig. 7.

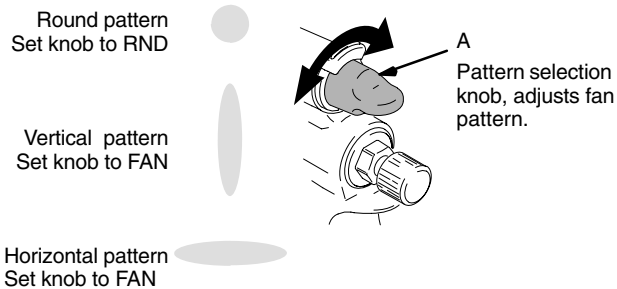

Fig. 7

T10825

Adjusting the Pattern

Change the pattern by adjusting the fluid knob (21) and pattern selection knob (A).

NOTE: Reducing the fluid flow rate or turning the air knob to RND will reduce the pattern width. Using **air cap 197056** will create a highly productive, wider pattern. See Fig. 8.

The air control (B) controls the TOTAL air to the pattern and gun. See Fig. 6.

As the fluid flow rate is reduced the pattern becomes smaller.

Using too much air will cause overspray.

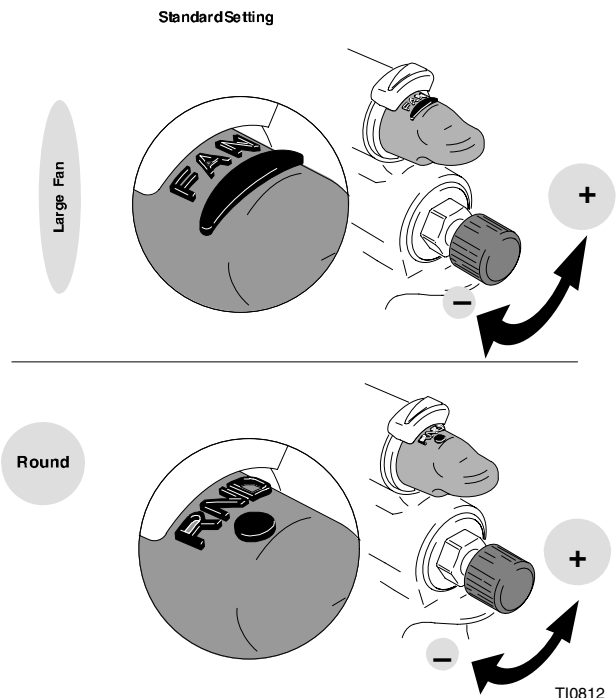

Fig. 8

Setup

Selecting Fluid Sets

The Turbine Spray Gun includes a #3 fluid set, Part No. 244124. **Grooves at the end of the fluid needle indicate the size of fluid set.**

Fluid sets include a nozzle (14a), o-ring (4) and needle assembly (14b). See Fig. 9.

NOTE: To order other replacement parts for gun, see parts drawing and list for gun model on page 23.

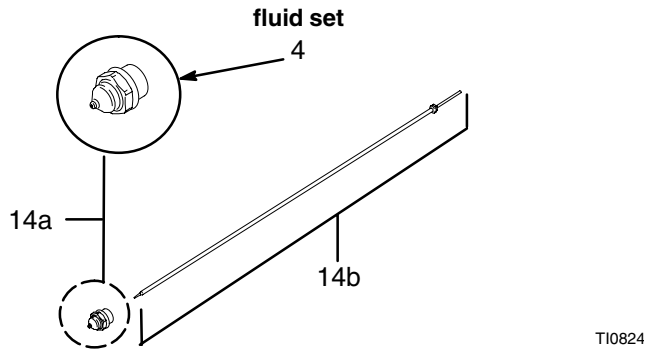

Fig. 9

! WARNING

Do not exceed the gun's 50 psi (0.35 MPa, 3.5 bar) Maximum Inlet Fluid Pressure and 10 psi (0.07 MPa, 0.7 bar) Maximum Inlet Air Pressure. Higher pressures can cause parts to rupture and result in serious injury or property damage.

Turbine spray gun fluid sets range in size to provide different fluid flow rates. Selection charts on page 8 show recommended combinations based on fluid viscosities, flow rates, and usage.

As a general guideline, use fluid nozzle that will give required flow with needle fully triggered at lowest fluid pressure.

For low flow rates or light viscosity fluid, select smaller nozzle sizes.

For high flow rates or high viscosity fluid, select larger nozzle sizes.

Graco offers six different fluid sets:

Fluid Set	Part Number	Orifice Size (inch)
#2	244123	0.032
#3	244124	0.051
#4	244125	0.071
#5	244126	0.087
#6	244127	0.098
#7	244128	0.115

Setup

Contractor Fluid Set Chart

Use this chart to determine Fluid Set for specific contractor application. Fig. 10.

Material / Fluid Set Selection Guide						
Material	Fluid Set #2	Fluid Set #3	Fluid Set #4	Fluid Set #5	Fluid Set #6	Turbine Unit
Dye Ink Non-Wiping Stain	██████████ ██████████ ██████████					2500
Automotive Finish Lacquer Stain Enamel Epoxy Urethane Varnish Primer	████████████████████	████████████████████ ████████████████████ ████████████████████ ████████████████████ ████████████████████	████████████████████ ████████████████████	████████████████████ ████████████████████ ████████████████████ ████████████████████		3800
Industrial Finishes Latex Multi-Spec Butyrate Nitrate Dope Oil Wall Paint				████████████████████ ████████████████████ ████████████████████	████████████████████ ████████████████████ ████████████████████	4900

197053 NOTE: Read gun manual for paint reduction recommendations.

Fig. 10

Installing the Fluid Set

⚠ CAUTION

Trigger the gun whenever you tighten or remove the nozzle. This keeps the needle seat away from the nozzle seating surface and prevents the seat from being scratched.

Complete spray guns are available with a #3 fluid set. To install other fluid sets, perform the following steps. See Fig. 11.

1. Use your hand to loosen and remove the air cap retaining ring (13) and the air cap housing (15).
2. While triggering the gun, use your hand to loosen and remove the nozzle (14a) from the gun.
3. Use your hand to loosen and remove the fluid knob assembly (21) and compression spring (23) from back of gun and remove the old needle.

4. Insert the needle assembly (14b) into the back of the gun. Replace the nozzle (14a) air cap housing (15) and air cap retaining ring and tighten by hand.

NOTE: O-ring (4) should always be on the nozzle.

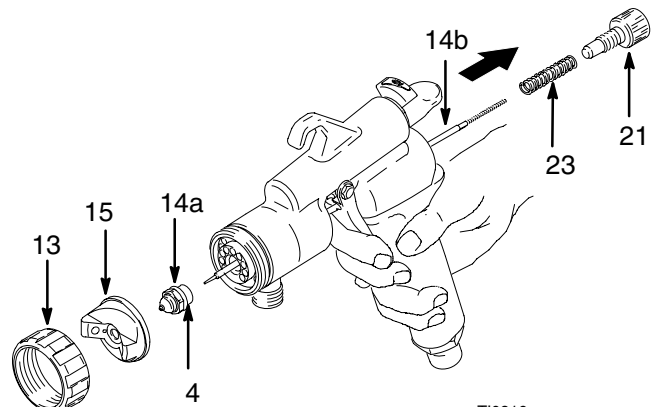

Fig. 11

T10816

Setup

Preparing to Spray

Paint Reduction — Industrial or Domestic Coatings

Reduce and catalyze all paint to manufacturer's specifications. If no reductions are given, first thoroughly mix fluid to be sprayed. Gradually mix in reducer, testing fluid for correct spraying consistency.

Test consistency, remove stir stick from thinned paint. Consistency is right when first drops from stir stick are about one second apart.

Prepare the Surface

To achieve proper adhesion, make sure the surface to be sprayed is completely clean.

Setup

Turbine Spray Unit (for more information see manual 309241)

Connect the Fluid and Air Supply

NOTES:

- The HVLP Cart/Compressor provides the air supply for the remote pressure pot.
- Circled letters in Fig. 12 indicate hose line connections.

1. Connect gun air supply hose (A) between turbine air outlet (B) and gun air inlet (C). DO NOT use wrench to tighten connections; hand tighten only. See Fig. 12.

2. If using a spray gun cup (D):
Connect cup to gun fluid inlet (E).

If using accessory remote pressure pots (F):
Connect fluid supply hose (G) between remote pressure pot fluid outlet (H) and gun fluid inlet (E), or connect pressure pot air hose (J) between pressure pot air regulator inlet (K) and the cart compressor air outlet (L).

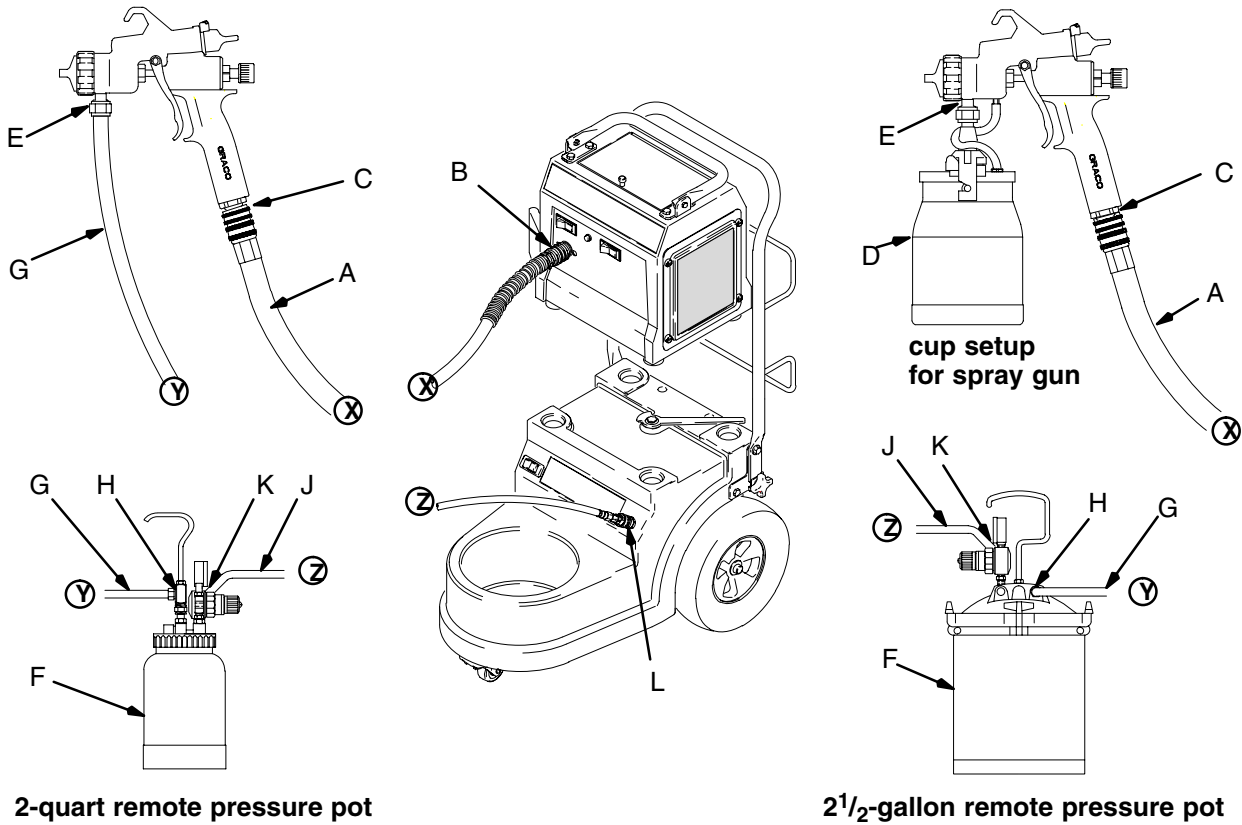

Fig. 12

8068A

Setup

Fill Cup or Remote Pressure Pot

Spray Gun Cup

⚠ WARNING

The spray gun cup is pressurized by the gun's air supply. To reduce the risk of serious injury from pressurized fluid or accidental spray from the gun, always turn off the air supply to the gun before removing the spray gun cup.

Fill cup 3/4 full to keep air pressure tube clean. Install cover. Latch the under-cup cover (H) to secure it to cup.

NOTE: Strainer may be removed for high viscosity applications which may plug strainer.

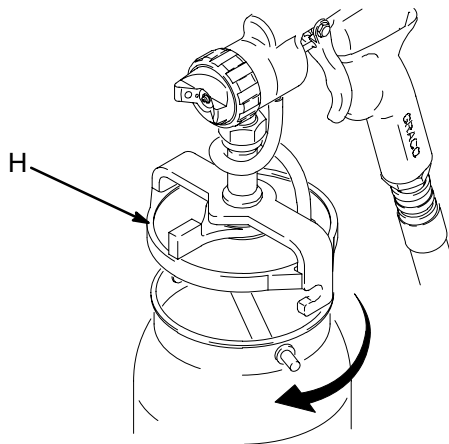

Fig. 13

Accessory Remote Pressure Pot

⚠ WARNING

The accessory remote pressure pots remain pressurized until pressure is manually relieved. To reduce the risk of serious injury from pressurized fluid or accidental spray from the gun, always relieve pressure in the pressure pot before loosening or removing the cover.

Pressure Relief Procedure

1. Relieve remote pressure pot pressure as follows (see Fig. 14):
 - a. Turn off air supply to pressure pot.

- b. 2¹/₂-gallon remote pressure pot:
Pull pressure relief valve ring (206c) until pressure is completely relieved.

2-quart remote pressure pot:

Turn **out** pressure relief knob (113) one turn. Wait until pressure is completely relieved before removing cover. Close knob.

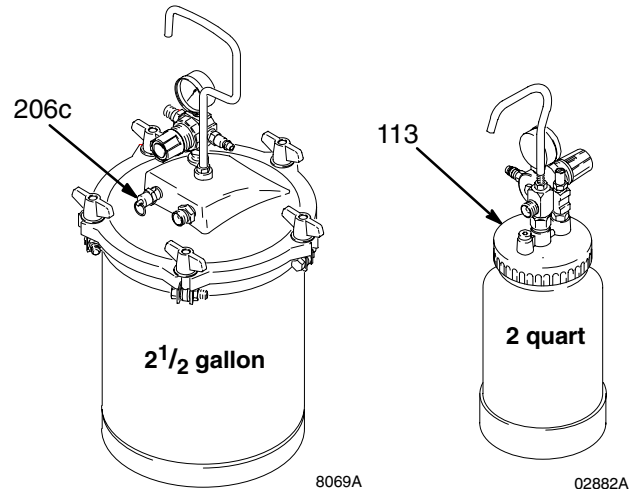

Fig. 14

2. Remove pressure pot cover and fill. Secure cover.

NOTE: 2-quart remote pressure pot only:
Lightly coat cover threads with petroleum jelly.

⚠ CAUTION

If the 2-quart remote pressure pot is accidentally tipped over or held at too great of an angle, fluid may leak into the air regulator and cause damage. Take precautions to avoid this. If fluid does get into the regulator, clean immediately.

⚠ CAUTION

Do not tighten the pressure pot cover more than hand-tight. Excessive tightening may damage the cover gasket.

Spraying Techniques

General Spraying Techniques

- Select proper fluid set. To determine correct fluid set see charts on page 8.
- When fluid is first applied, start with fluid valve and maximum air and the knob set to the FAN spray pattern position. Then adjust as needed. See Fig. 8 for pattern size adjustment.
- Keep gun perpendicular to surface and maintain consistent distance of approximately 6 to 8 inches (150 to 200 mm) from object being sprayed. See Fig. 15.
- Always have spray gun in motion before triggering. Move spray gun across workpiece in straight, smooth, stroke. Maintaining speed and distance. Release trigger at end of stroke.
- To obtain even finish, overlap previous strokes by 50%.
- Apply full, wet coat whenever possible.

Automotive Spraying Techniques

- When blending spots, work from outside in.
- Two 20-foot (6.1 m) hoses are recommended when applying automotive finish coats. Additional hose allows air to cool for better flow.

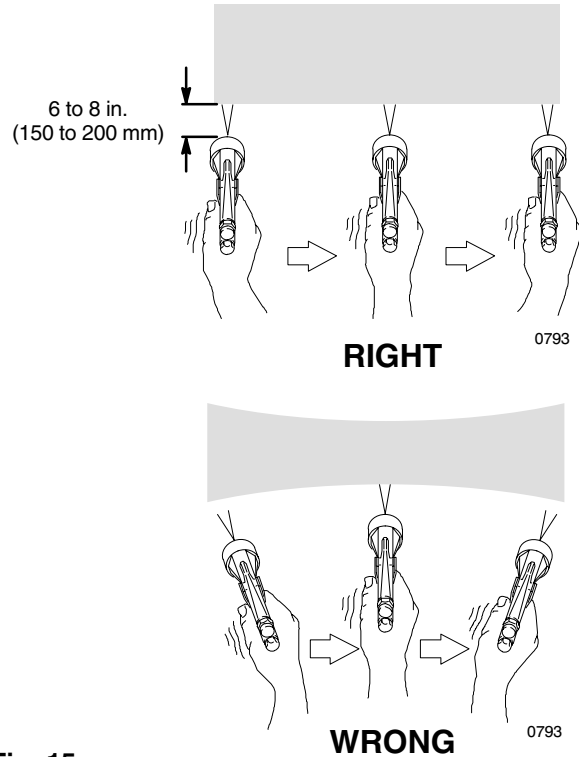

Fig. 15

Spraying Techniques

Swivel Tube Adjustment

The adjustable swivel tube allows the HVLP-Turbine Gun to be held in any position when spraying. To adjust the position of the tube in the cup:

1. Loosen the nut (A) with a wrench (42).
2. Rotate the cup to the desired spray position.
3. Retighten the nut (A) with a wrench (42).

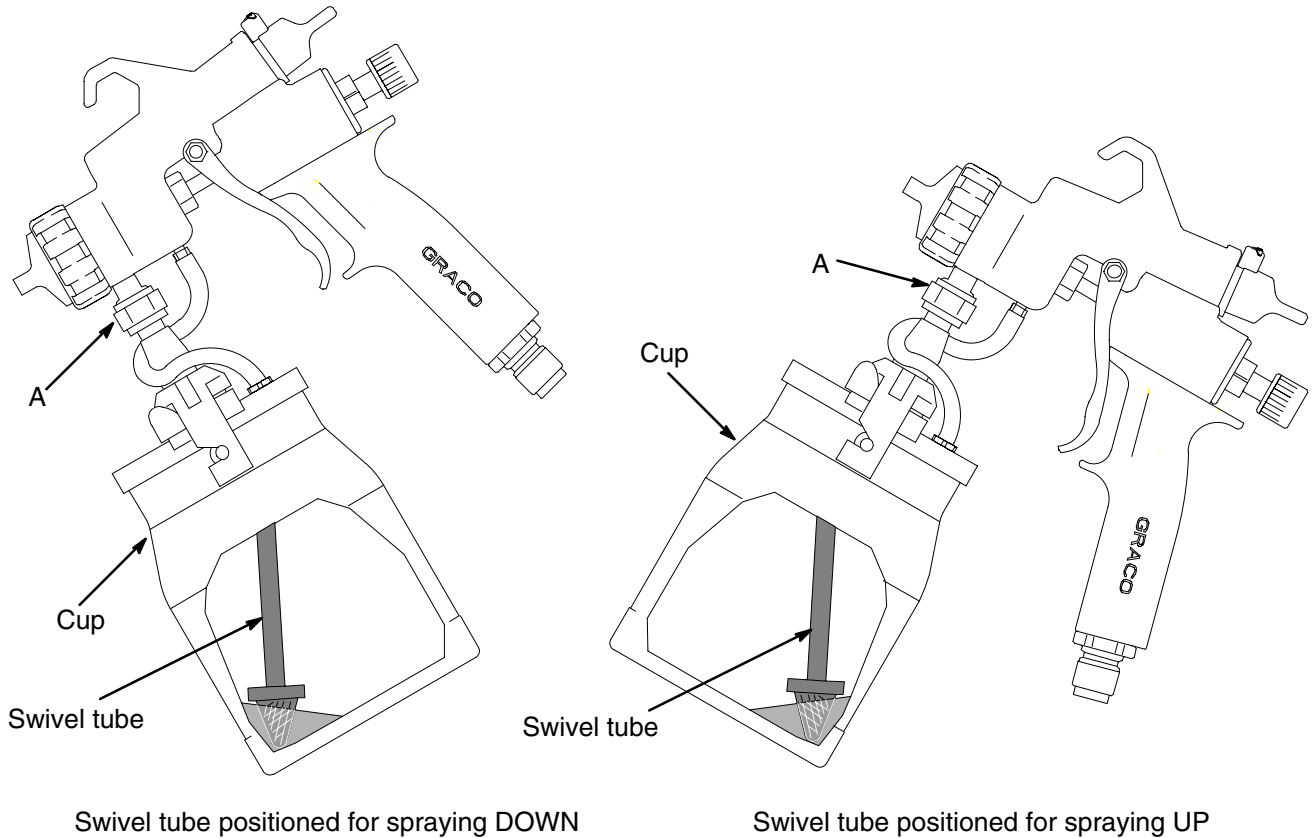

T10804

Fig. 16

Converting the HVLP Turbine Cup Feed Gun to Pressure Feed *(Parts, page 22)*

1. Using a pair of pliers, remove air pressure tube (30b) from air stem (31).
2. Hold adapter fitting (28) with wrench. Remove cup assembly.
3. Remove air stem (31) from gun body (1).
4. Apply medium strength thread locker to set screw (36) and assemble into gun body (1).

NOTE: To convert from pressure feed cup to cup feed, reverse these instructions.

Maintenance

Cleaning the Spray Gun

1. Clean gun and cup by hand with compatible solvent or place them in gun washer with trigger held open; cycle washer as necessary to clean gun.
2. Remove air cap retaining ring (13), air cap (15), nozzle (14a) and o-ring (4). See Fig. 17.
3. Trigger gun while using your hand to remove the fluid nozzle (14a). See Fig. 17.

⚠ CAUTION

Trigger the gun whenever you tighten or remove the nozzle. This keeps the needle seat away from the nozzle seating surface and prevents the seat from being scratched.

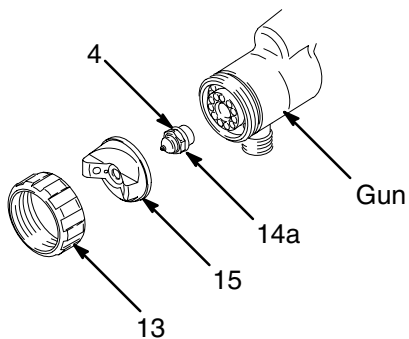

Fig. 17

TI0884

4. Clean the air cap retaining ring, air cap, and fluid nozzle with water or solvent.
5. Dip the end of a soft-bristle brush into a compatible solvent. Do not continuously soak the brush's bristles with solvent and do not use a wire brush.

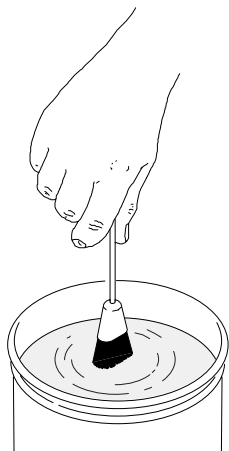

Fig. 18

02007

6. With the gun pointed down, clean the front of the gun, using the soft-bristle brush and solvent.

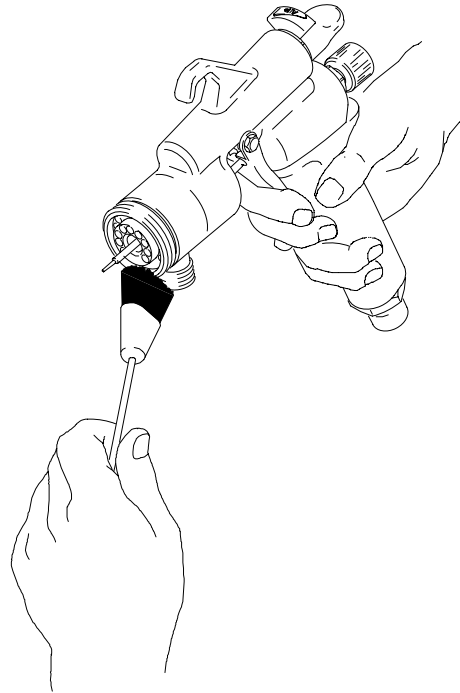

Fig. 19

TI0817

7. Scrub the air cap retaining ring, air cap, and fluid nozzle with the soft-bristle brush. To clean out air cap holes, use a soft implement, such as a toothpick, to avoid damaging critical surfaces. Clean the air cap and fluid nozzle daily, minimum. Some applications require more frequent cleaning. Do not soak the air cap retaining ring in solvent for prolonged periods of time.

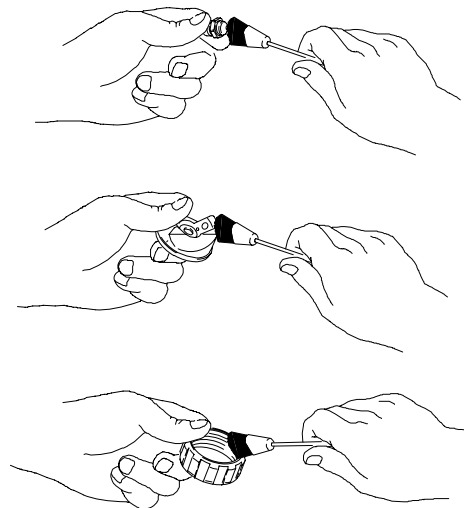

Fig. 20

TI0813

Maintenance

8. Trigger gun while hand tightening the fluid nozzle (14a).
9. Install air cap (15) and retaining ring (13).
10. Dampen a soft cloth with solvent. Wring out the excess. Point the gun down and wipe off the outside of the gun.
11. Lubricate gun after cleaning it as instructed on page 17.

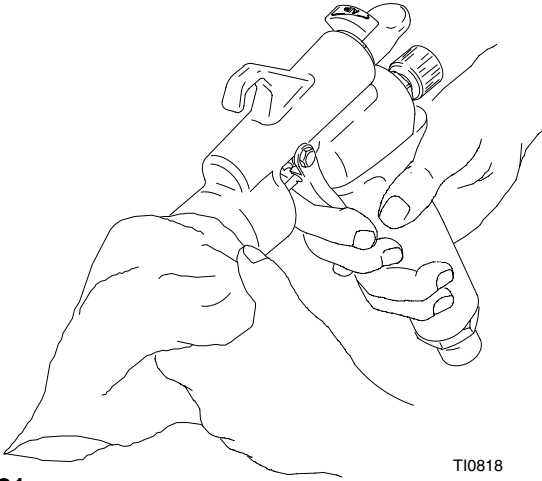

Fig. 21

T10818

CAUTION

Solvent left in gun air passages could result in a poor quality paint finish. Do not use any cleaning method which may allow solvent into the gun air passages.

Do not point the gun up while cleaning it.

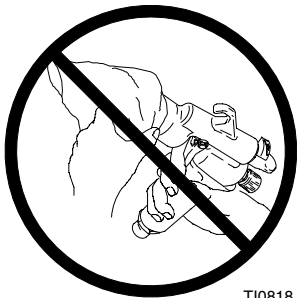

T10818

Do not wipe the gun with a cloth soaked in solvent; ring out the excess.



02027

Do not immerse the gun in solvent.



07041A

Do not use metal tools to clean the air cap holes as this may scratch them; scratches can distort the spray pattern.



02055

Maintenance

Flushing the Spray Gun Using a Remote Pressure Pot

NOTES:

- Check for any fluid leakage from gun and fluid hoses. Tighten fittings or replace equipment as needed.
- Flush gun before you change colors and when you are finished spraying.

CAUTION

Clean all parts with a solvent compatible with the fluid being sprayed and compatible with the spray gun and cup or accessory remote pressure pot wetted parts. See **Technical Data** on page 21.

1. Turn off air supply to gun.
2. Follow the pressure relief procedure described on page 11.
3. Fill pressure pot with water or a compatible solvent.
4. Flush spray gun, using compressor air only. Point gun down into container and flush until solvent runs clean.
5. Relieve pressure pot pressure, following the pressure relief procedure described on page 11.
6. Disconnect air and fluid hoses from gun.
7. Clean and lubricate gun as instructed starting on page 14.

Flushing the Spray Gun and Cup

1. Turn off air supply to gun.
2. Unlatch cup cover, and remove cup from cover.
3. Turn the pattern selection knob (A) to RND to create a round pattern. Turn air control valve (B) half open to reduce solvent mist.
4. Fill empty cup with about 1½ inches (38 mm) of compatible solvent, and reinstall cup. Be sure cover is secured.
5. Turn on air to gun.
6. Point gun down into and ground against container and flush until solvent runs clean. See Fig. 22.

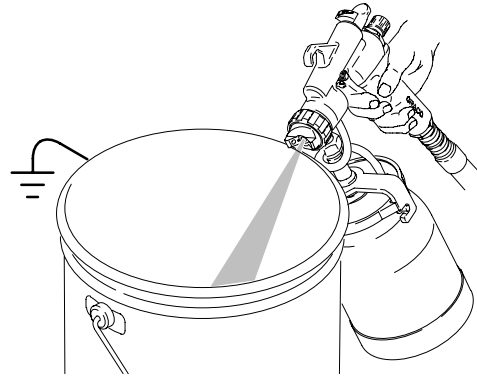

Fig. 22

7. Turn off air to gun.
8. Disconnect air supply and remove cup from gun. Clean and lubricate gun as instructed on pages 14 and 17.

Service

Lubricating the Spray Gun

After cleaning or servicing gun, lubricate parts indicated in Fig. 23 with silicone-free spray gun lubricant or similar material.

- All threaded areas (A)
- Trigger screws (B)
- Trigger axle (C)
- Fluid needle assembly (D) (see #16, Parts, page 22)

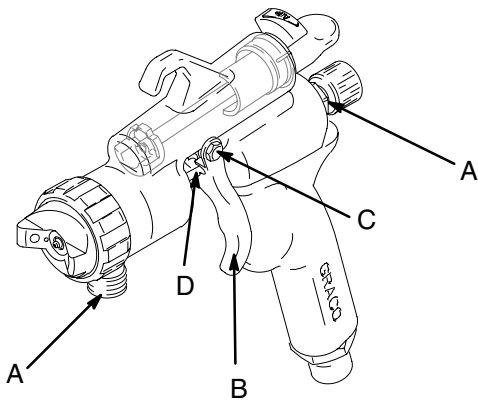

T10883

Fig. 23

Replacing the Needle

⚠ WARNING

PRESSURIZED EQUIPMENT HAZARD

To reduce the risk of a serious injury, follow the **Pressure Relief Procedure** on page 11 before checking or repairing any part of the gun or system.

1. Relieve the pressure.

⚠ CAUTION

Trigger the gun whenever you tighten or remove the nozzle. This keeps the needle seat away from the nozzle seating surface and prevents the seat from being scratched.

2. Remove the fluid adjustment knob (21) and fluid spring (23).
3. Pull the fluid needle assembly (16) out the back of the gun.
4. Check the fluid needle (16) for damage or excessive wear. Replace needle if necessary.
5. Insert the fluid needle assembly (16) into the back of the gun.
6. Tighten the packing screw (8). The needle (16) must move freely.

NOTE: To ensure proper alignment of the parts, follow the next steps in the order they are given.

7. Lubricate and install the fluid needle (16).
8. Lubricate the fluid adjustment knob threads (21), and install the fluid spring (23) and adjustment knob.
9. Trigger the gun to test the needle movement. If the needle does not return after the trigger is released or is slow in returning, loosen the packing screw (8) slightly until the needle returns freely.
10. Make sure the gun fluid packings are sealing properly by spraying solvent at low pressure before fully pressurizing the gun with the fluid to be sprayed.

If the fluid packings leak, tighten the packing screw (8) slightly and retest until the packings and needle seal completely.

Service

Replacing the Air Valve (243840)

The air valve (25) cannot be repaired. If it is damaged, the entire piece must be replaced.

To remove the air valve, use a screwdriver to gently push the valve back about 0.25", then gently pull it out of the back of the gun. Insert the new air valve, twist counter-clockwise (approximately one-half turn) until it is securely seated in the back of the gun. Fig. 24.

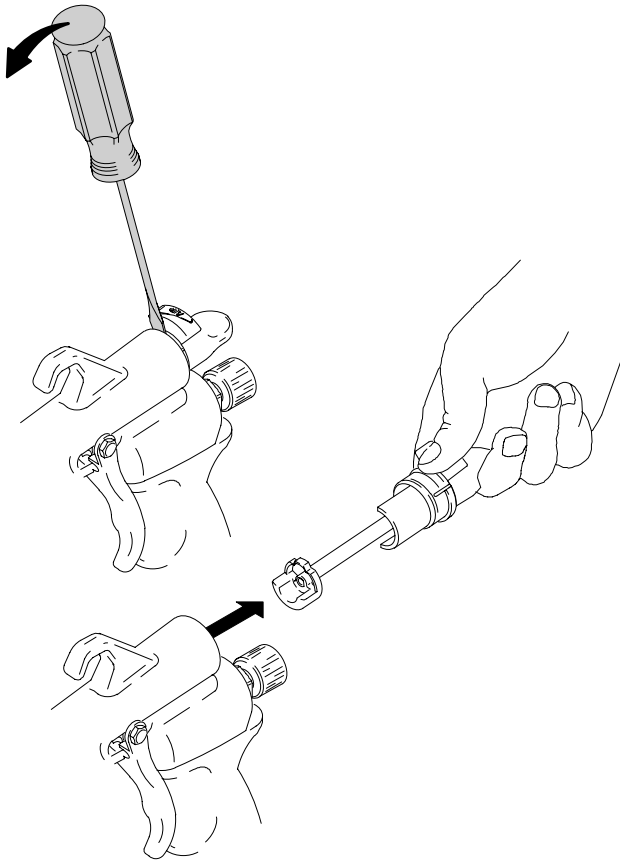

Fig. 24

Replacing the Duckbill Valve (Kit – 244135)

If the duckbill valve is worn or broken, replace it with a new one immediately. To replace the duckbill valve:

1. Lift the cover away from the cup.
2. Using a screwdriver, slightly pull the worn duckbill valve and o-ring out of the lid.

3. Put the o-ring on the new duckbill valve.
4. Press the new duckbill valve and o-ring onto the lid.

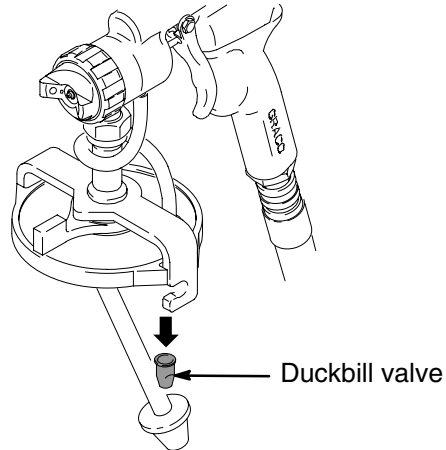

TI0810

Fig. 25

Replacing the Cup Gasket (Kit – 240625)

If the gasket is worn or swelled, replace it with a new one immediately. To replace the cup gasket:

1. Lift the cover away from the cup.
2. Remove the worn gasket.
3. Press a new gasket into the lid slot.

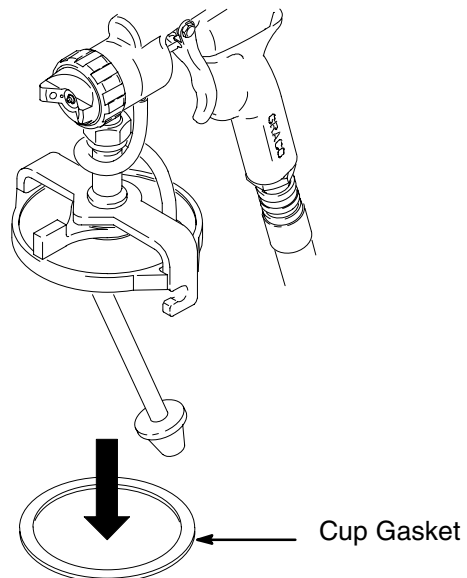

Fig. 26

Troubleshooting

Spray Finish Problems

PROBLEM	CAUSE	SOLUTION
Orange peel finish — Paint surface not smooth	Paint droplets too large	<ul style="list-style-type: none"> ● Maintain proper spraying distance. See page 12. ● Keep the turbine air filters clean to allow full air flow. ● Do not use an air hose that is too long to provide sufficient atomization pressure. ● If droplets are still too large, reduce the fluid.
	Paint droplets drying too fast to properly flow out of gun	Keep the object being sprayed out of direct sunlight. When spraying in warmer temperatures, use a slower evaporating solvent or a retarder.
	Cold weather spraying	Keep the fluid and the object being sprayed as close to room temperature as possible. When sprayed on a cold surface, most paints will become too thick to flow properly.
Blushing — Clear coatings appear milky	Moisture condensation is trapped in the lacquer when spraying in hot, humid conditions	<ul style="list-style-type: none"> ● Allow the turbine to warm up a few minutes before spraying. ● Store the lacquer off concrete floors, at room temperature. ● Apply lighter coats and allow for proper drying time. ● Use a slower evaporating solvent or retarder. ● Do not spray in windy conditions.
Fish eyes — Small pools on painted surface that will not fill	Silicone contamination from lubricants, grease, polish, or waxes on the surface being sprayed	Clean all parts with a cleaning solvent; use a solvent rag and a clean rag to wipe with. Replace rags as needed. If the problem persists, use a fish eye eliminator.
Runs and sags	Applying too much paint per pass for the drying conditions	<ul style="list-style-type: none"> ● Move the gun faster or decrease the fluid flow. ● Maintain proper spraying distance. See page 12. ● Reduce the amount of thinner or use a faster drying thinner.
Solvent pops or bubbles	Sprayed surface drying before solvent gas can be released	<ul style="list-style-type: none"> ● Apply fluid in lighter coats to allow for proper evaporation. ● Use the recommended thinners. ● Follow the solutions, above, for <i>Orange peel finish — Paint droplets too large</i>.

Troubleshooting

Spray Gun Problems

PROBLEM	CAUSE	SOLUTION
No or slow fluid flow, intermittent spray, or fluttering spray	Wrong size fluid set being used or the o-ring on nozzle is missing	Select the proper fluid set for the fluid being sprayed (see page 8) or put an o-ring on the nozzle.
	Gun fluid nozzle blocked by dried paint, or damaged	Clean or replace fluid nozzle.
	Cup or pressure pot cover not tight enough, or gasket damaged	Tighten cover or replace gasket.
	Cup or pressure pot fluid tube blocked by dried paint or damaged	Clean or replace fluid tube.
	Air flow to cup blocked	To check, remove the cup (leave cover connected), trigger the gun and check for air flow out of the duckbill valve. If air is not flowing freely, clean or replace the duckbill valve.
	Needle packings not properly adjusted NOTE: Fluid loss through the packings affects fluid pressure and causes a fluid leak from the gun body.	Clean the gun body with solvent and the brush provided. Adjust the needle packings.
	Plugged inlet strainer	Replace strainer if plugged or remove strainer if material is highly viscous.
Fluid leaks at fluid nozzle after the trigger is released	Needle not seating in fluid nozzle	Check for a loose fluid nozzle or a bent nozzle or needle; tighten the nozzle or replace parts as needed.
Poor spray pattern	Air cap horn holes and/or fluid nozzle plugged	Soak air cap and/or fluid nozzle in solvent. Clean air cap horn holes with non-metallic item to avoid permanently damaging them. See page 14.

Technical Data

Maximum inlet fluid pressure	50 psi (0.35 MPa, 3.5 bar)
Maximum inlet air pressure	10 psi (0.07 MPa, .7 bar)
Air inlet	Quick-disconnect
Fluid inlet	3/8 nps
Sound levels per ISO 3744	
Sound power level	less than 65.0 dB(A)
Sound pressure level	less than 65.0 dB(A)
Wetted parts	
Bare spray gun	stainless steel, aluminum
Spray gun cups	aluminum, polyethylene
2-quart accessory remote pressure pot	aluminum, polyethylene
2 ¹ / ₂ -gallon accessory remote pressure pot	steel with solvent-resistant finish, EPDM gasket (standard)

Parts for HVLP-Turbine Gun

Model Nos. 244113, 244115, 244117, 244118

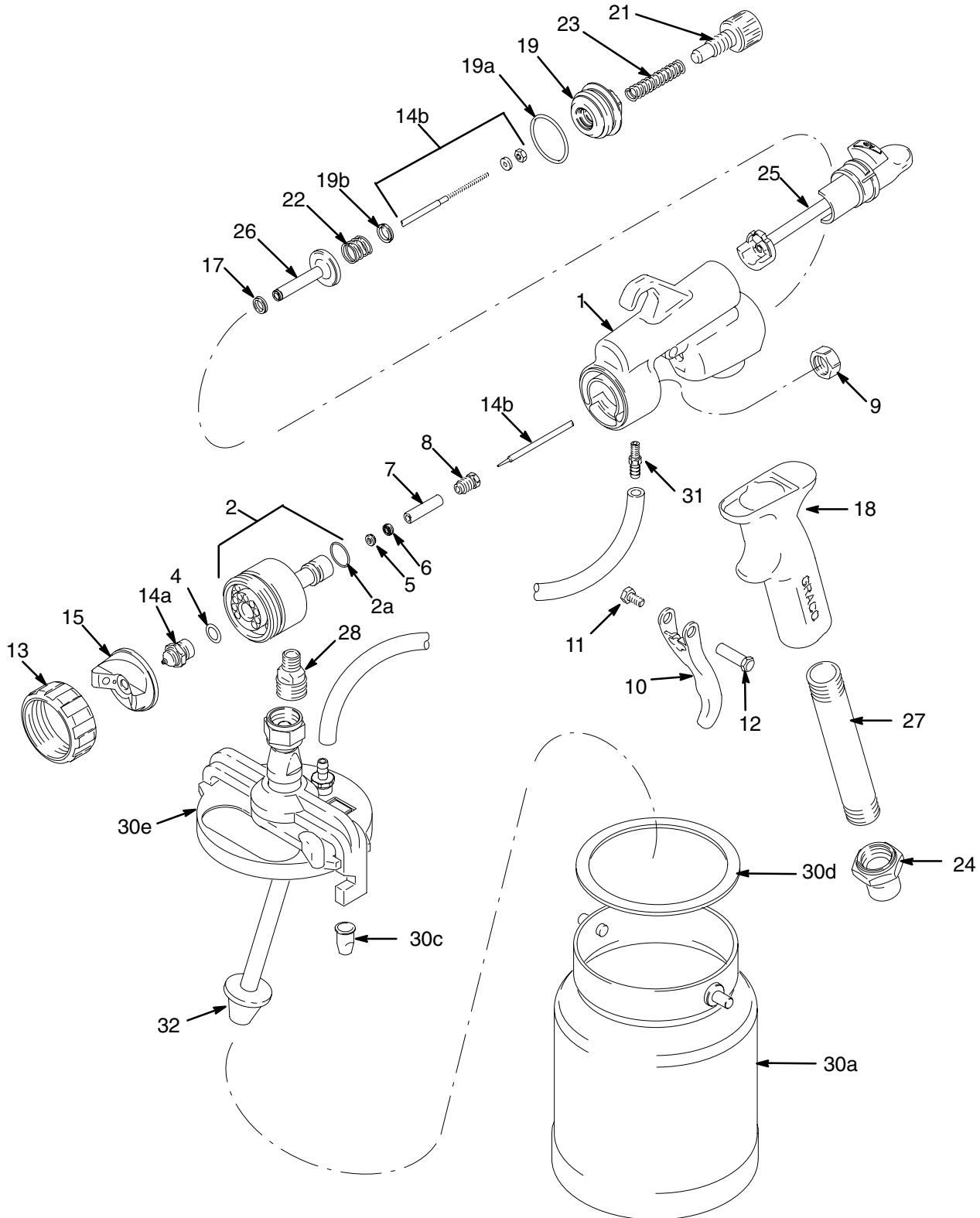

Parts for HVLP–Turbine Gun

Model Nos. 244113, 244115, 244117, 244118

Ref. No.	Part No.	Description	Qty.	Ref. No.	Part No.	Description	Qty.
1	244426	BODY, gun	1	25	243840	VALVE, air fan	1
2	244429	HOUSING, nozzle	1	26	243842	VALVE, air	1
2a	112085	PACKING, o–ring	1	27	196463	TUBE, handle	1
4	113137	PACKING, o–ring	1	28	196468	FITTING, adapter	1
5	188494	SPREADER, u–cup,	1	30†	244130	CUP UNDER, kit	1
6	188495	PACKING, u–cup	1	30a†	244132	CUP, 1 quart	1
7	196438	SPACER, packing	1	30b†	244133	AIR TUBE kit – 5 pack (not shown)	1
8	192352	SCREW, packing	1	30c†	244135	VALVE, duckbill	1
9	192348	NUT, hex; 1/2–20 UNF	1	30d†	240265	GASKET, cup	1
10	196439	TRIGGER	1	30e†	243714	LID, assembly	1
11	203953	SCREW, cap, hex head	1	31†	M70394	STEM, air	1
12	192272	PIN, pivot	1	32	193218	STRAINER	1
13	196415	RING, retaining, air cap	1	33	M70613	BRUSH, cleaning (not shown)	1
14	244124	FLUID SET	1	34	070303	LUBRICANT, grease (not shown)	1
14a		NOZZLE, fluid	1	35	197448	TOOL, wrench (not shown)	1
14b		NEEDLE ASSY	1	36	M71149	SCREW, set	1
15	244226	HOUSING, air cap	1				
17	188493	PACKING, u–cup, gun	1				
18	196462	HANDLE, gun	1				
19	244428	HOUSING, valve, fluid	1				
19a	110066	PACKING, o–ring	1				
19b	110453	PACKING, u–cup	1				
21	196649	KNOB, fluid control	1				
22	114069	SPRING, compression	1				
23	114072	SPRING, compression	1				
24	196464	COUPLER, male	1				

*Not included on model 244113 or 244115.
†Not included on model 244115 or 244118.

Graco Standard Warranty

Graco warrants all equipment manufactured by Graco and bearing its name to be free from defects in material and workmanship on the date of sale by an authorized Graco distributor to the original purchaser for use. With the exception of any special, extended, or limited warranty published by Graco, Graco will, for a period of twelve months from the date of sale, repair or replace any part of the equipment determined by Graco to be defective. This warranty applies only when the equipment is installed, operated and maintained in accordance with Graco's written recommendations.

This warranty does not cover, and Graco shall not be liable for general wear and tear, or any malfunction, damage or wear caused by faulty installation, misapplication, abrasion, corrosion, inadequate or improper maintenance, negligence, accident, tampering, or substitution of non-Graco component parts. Nor shall Graco be liable for malfunction, damage or wear caused by the incompatibility of Graco equipment with structures, accessories, equipment or materials not supplied by Graco, or the improper design, manufacture, installation, operation or maintenance of structures, accessories, equipment or materials not supplied by Graco.

This warranty is conditioned upon the prepaid return of the equipment claimed to be defective to an authorized Graco distributor for verification of the claimed defect. If the claimed defect is verified, Graco will repair or replace free of charge any defective parts. The equipment will be returned to the original purchaser transportation prepaid. If inspection of the equipment does not disclose any defect in material or workmanship, repairs will be made at a reasonable charge, which charges may include the costs of parts, labor, and transportation.

THIS WARRANTY IS EXCLUSIVE, AND IS IN LIEU OF ANY OTHER WARRANTIES, EXPRESS OR IMPLIED, INCLUDING BUT NOT LIMITED TO WARRANTY OF MERCHANTABILITY OR WARRANTY OF FITNESS FOR A PARTICULAR PURPOSE.

Graco's sole obligation and buyer's sole remedy for any breach of warranty shall be as set forth above. The buyer agrees that no other remedy (including, but not limited to, incidental or consequential damages for lost profits, lost sales, injury to person or property, or any other incidental or consequential loss) shall be available. Any action for breach of warranty must be brought within two (2) years of the date of sale.

Graco makes no warranty, and disclaims all implied warranties of merchantability and fitness for a particular purpose in connection with accessories, equipment, materials or components sold but not manufactured by Graco. These items sold, but not manufactured by Graco (such as electric motors, switches, hose, etc.), are subject to the warranty, if any, of their manufacturer. Graco will provide purchaser with reasonable assistance in making any claim for breach of these warranties.

In no event will Graco be liable for indirect, incidental, special or consequential damages resulting from Graco supplying equipment hereunder, or the furnishing, performance, or use of any products or other goods sold hereto, whether due to a breach of contract, breach of warranty, the negligence of Graco, or otherwise.

FOR GRACO CANADA CUSTOMERS

The parties acknowledge that they have required that the present document, as well as all documents, notices and legal proceedings entered into, given or instituted pursuant hereto or relating directly or indirectly hereto, be drawn up in English. Les parties reconnaissent avoir convenu que la rédaction du présente document sera en Anglais, ainsi que tous documents, avis et procédures judiciaires exécutés, donnés ou intentés à la suite de ou en rapport, directement ou indirectement, avec les procédures concernées.

ADDITIONAL WARRANTY COVERAGE

Graco does provide extended warranty and wear warranty for products described in the "Graco Contractor Equipment Warranty Program".

Graco Phone Number

TO PLACE AN ORDER, contact your Graco distributor, or call this number to identify the distributor closest to you:
1-800-690-2894 Toll Free

*All written and visual data contained in this document reflect the latest product information available at the time of publication.
Graco reserves the right to make changes at any time without notice.*

Sales Offices: Minneapolis, Detroit
International Offices: Belgium, Korea, Hong Kong, Japan

GRACO INC. P.O. BOX 1441 MINNEAPOLIS, MN 55440-1441

www.graco.com

PRINTED IN USA 309205, December 2000, Revised October 2003