

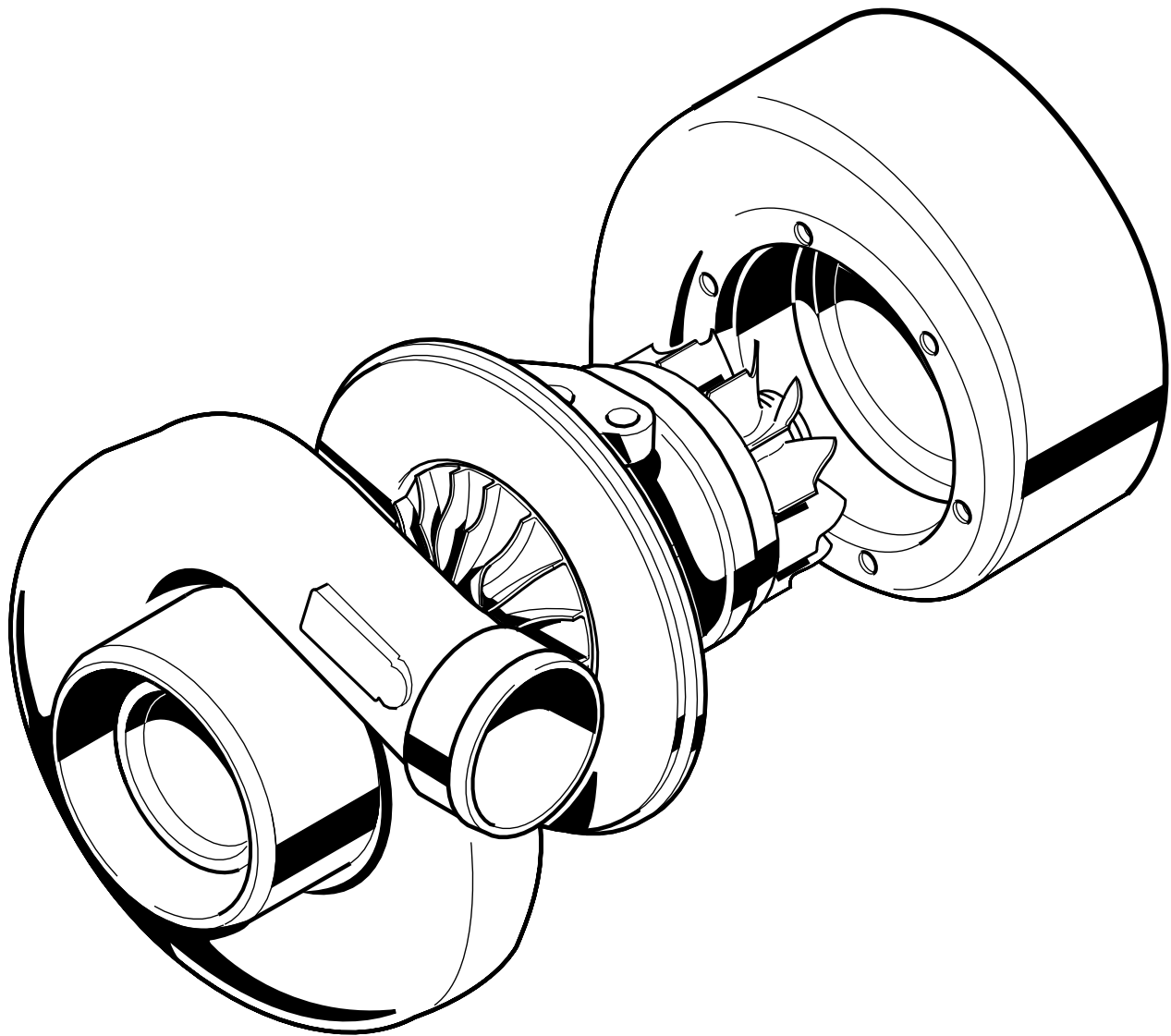

HX35/40

Service Repair Manual

For updates of this manual please visit
www.holset.co.uk



Foreword

This publication was written to assist field personnel with basic overhaul and rebuilding of the Holset HX30/35/40 turbocharger.

The specifications and rebuild information in this manual is based on information in effect at the time of printing. Holset Service reserves the right to make any changes at any time without obligation. If differences are found between your turbocharger and the information in this manual, contact your local approved dealer.

The latest technology and the highest quality standards are used in the manufacture of Holset Turbochargers. When replacement parts are needed, we recommend using only genuine Holset parts.

Table of Contents

Introduction

General Information	4
About the Manual.....	4
How to Use the Manual	4
Fault Finding Chart	5
Symbols	6

Component Identification

Turbocharger Identification.....	11
Components	12
Exploded View	13
Optional Components	14

Component Disassembly and Assembly

Service Tools	15
Disassembly	16
Cleaning.....	21
Inspection	21
Assembly	23
Installation Data	30
Installation Checklist	31

Introduction

General Information

A turbocharger is a mechanical device which uses the engine's exhaust gases to force more air into the engine cylinders. A turbocharger uses energy from the engine to help increase its overall efficiency. Hot exhaust gas energy is used to turn a "shaft and wheel". At the other end of the shaft is the "compressor impeller" (or compressor wheel), which draws in air and forces it into the engine cylinders.

Supplying increased air mass flow to the engine provides improved engine performance, lower exhaust smoke density, improved operating economy, altitude compensation, and noise reduction. The turbocharger has proven to be one of the most beneficial devices for improving engine performance. It performs its job very well, as long as it is properly cared for.

About the Manual

The procedures in this manual were developed to instruct in the correct overhaul of the Holset HX35/40 turbocharger to provide for the optimum performance and minimum of maintenance operation.

How to Use the Manual

This manual is organised according to the steps needed to most easily and correctly overhaul the Holset HX35/40 turbocharger. In the unlikely event of turbocharger malfunction, please check the Fault Finding Chart to identify potential causes, before attempting disassembly. To make sure of optimum performance, certain items must be discarded during the disassembly operation and replaced with new for re-assembly. These items are indicated in the disassembly section with the use of a * symbol. All items showing a * are available in a basic HX35/40 overhaul kit. Contact your local agent for part number and availability.

Warning

This turbocharger may have been manufactured using the 'core balance' process and therefore **MUST** be check balanced on rebuild.

A core balanced turbocharger will not have any co-relation marks on the thrust collar or oil slinger, and also may not have co-relation marks on the end of the turbine shaft and impeller nose.

If you intend to overhaul/repair a core balanced turbocharger, and do not have access to a core balancing machine, we recommend that you make your own rotor co-relation marks during disassembly (see appropriate illustration in the disassembly section) with an indelible-ink pen, so that these parts can be reassembled in the same relative positions.

Please refer to the balance data section of this manual for the balance limits to be used for either core balancing or rotor balancing.

It is important to note that operating a turbocharger with a Rotor or Core balance level greater than the published limits could cause turbocharger or engine failure. If you are in any doubt regarding the balancing process, please contact an approved Holset distributor for assistance.

Fault Finding Chart

	Engine Running Hot	Poor Transient Response	Smoke	Engine Lacks Power	Black Exhaust Smoke	Blue Exhaust Smoke	High Oil Consumption	Turbocharger Noisy	Cyclic Sound from the Turbocharger	Oil Leak from Compressor Seal	Oil Leak from Turbine Seal
Dirty air cleaner Clean or replace element according to manufacturer's recommendations	●	●	●	●	●	●	●			●	
Restricted compressor intake duct Remove restriction or replace damaged parts as required	●	●	●		●	●	●	●	●	●	
Restricted air duct from compressor to intake manifold Remove restriction or replace damaged parts as required	●	●		●	●			●			
Restricted intake manifold Refer to engine manufacturer's manual and remove restriction	●	●		●	●			●			
Air leak in feed from air cleaner to compressor Replace seals, gaskets or tighten fasteners as required								●			
Air leak in feed from compressor to intake manifold Replace seals, gaskets or tighten fasteners as required	●	●	●	●	●	●	●	●			
Air leak between intake manifold and engine Refer to engine manufacturer's manual and replace gaskets or tighten fasteners as required	●		●	●	●	●	●	●			
Foreign object in exhaust manifold (from engine) Refer to engine manufacturer's manual and remove obstruction				●	●	●	●	●		●	
Restricted exhaust system Remove restriction or replace damaged parts as required	●			●	●					●	
Exhaust manifold cracked, gaskets blown or missing Refer to engine manufacturer's manual and replace gaskets or damaged parts as required		●	●	●	●			●			
Gas leak at turbine inlet/exhaust manifold joint Replace gasket or tighten fasteners as required		●	●	●	●			●			
Gas leak in ducting after turbine outlet Refer to engine manufacturer's manual and repair leak		●						●			
Restricted turbocharger oil drain line Remove restriction or replace damaged parts as required						●	●			●	●
Restricted engine crankcase breather Refer to engine manufacturer's manual, clear restriction						●	●			●	●
Turbocharger bearing housing sludged or coked Change engine oil and oil filter, overhaul or replace turbocharger as required						●	●			●	●
Fuel injection pump or fuel injectors incorrectly set Refer to engine manufacturer's manual and replace or adjust faulty components as required		●	●	●	●						
Engine valve timing incorrect Refer to engine manufacturer's manual for correct settings and adjust as required				●	●						
Worn engine piston rings or liners Refer to engine manufacturer's manual and repair as required				●	●	●	●			●	●
Burnt valves and/or pistons Refer to engine manufacturer's manual and repair as required				●	●	●	●			●	●
Excessive dirt build up on compressor wheel and/or diffuser vanes Clean in accordance with details in the appropriate Holset publication				●	●	●	●	●	●	●	●
Turbocharger damaged Find and correct cause of failure, repair or replace turbocharger as necessary				●	●	●	●	●		●	●
Failed diaphragm Replace using correct actuator Service Kit	●							●			
Siezed valve Free valve/replace complete turbine housing sub-assembly	●	●									
Leaking hose Replace hose and clips	●							●			
Wastegate mechanism set incorrectly Contact approved agent for correct setting details	●	●	●	●				●			

Symbols - English

The following group of symbols have been used in this manual to help communicate the intent of the instructions. When one of the symbols appears, it conveys the meaning defined below.



WARNING - Serious personal injury or extensive property damage can result if the warning instructions are not followed.



CAUTION - Minor personal injury can result or a part, an assembly or the engine can be damaged if the caution instructions are not followed.



Indicates a **REMOVAL or DISASSEMBLY** step.



Indicates an **INSTALLATION or ASSEMBLY** step.



INSPECTION is required.



CLEAN the part or assembly.



PERFORM a mechanical or time **MEASUREMENT**.



LUBRICATE the part or assembly.



Indicates that a **WRENCH or TOOL SIZE** will be given.



TIGHTEN to a specific torque.



Ensure that the **BALANCE MARKS** on the rotor assembly are in alignment



PERFORM an electrical **MEASUREMENT**.



Refer to another location in this manual or another publication for additional information.



Please wear protective clothing at all times.

Simbolos - Español

Los simbolos siguientes son usados en este manual para clarificar el proceso de las instrucciones. Cuando aparece uno de estos simbolos, su significado se especifica en la parte inferior..



ADVERTENCIA - Serios daños personales o daño a la propiedad puede resultar si las instrucciones de Advertencia **no** se consideran.



PRECAUCION - Daños menores pueden resultar, o de piezas del conjunto o el motor puede averiarse si las instrucciones de Precaución **no** se siguen.



Indica un paso de **REMOCION** o **DESMONTAJE**.



Indica un paso de **INSTALACION** o **MONTAJE**.



Se requiere **INSPECCION**.



LIMPIESE la pieza o el montaje.



EJECUTESE una **MEDICION** mecánica o del tiempo.



LUBRIQUESE la pieza o el montaje.



Indica que se dará una **LLAVE DE TUERCAS** o el **TAMAÑO DE HERRAMIENTA**.



APRIETESE hasta un par torsor específico.



Cerírese de que están alineadas las **MARCAS DE BALANCE** en el rotor.



EJECUTESE una **MEDICION** eléctrica.



Para información adicional refiérase a otro emplazamiento de este manual o a otra publicación anterior.



Favor de siempre llevar ropa protectora.

Symbole - Deutsch

In diesem Handbuch werden die folgenden Symbole verwendet, die wesentliche Funktionen hervorheben. Die Symbole haben folgende Bedeutung:



WARNUNG - Wird die Warnung nicht beachtet, dann besteht erhöhte Unfall- und Beschädigungsgefahr



VORSICHT - Werden die Vorsichtsmassnahmen nicht beachtet, dann besteht Unfall- und Beschädigungsgefahr.



AUSBAU bzw. **ZERLEGEN**.



EINBAU bzw. **ZUSAMMENBAU**.



INSPEKTION erforderlich.



Teil oder Baugruppe **REINIGEN**.



DIMENSION - oder **ZEITMESSUNG**.



Teil oder Baugruppe **ÖLEN**.



WERKZEUGGRÖSSE wird angegeben.



ANZUG auf vorgeschriebenes Drehmoment erforderlich.



Sicherstellen, daß die **AUSWUCHTMARKEN** an der Rotor-Baugruppe richtig ausgerichtet sind.



Elektrische **MESSUNG DURCHFÜHREN**.



Weitere Informationen an anderer Stelle bzw. in anderen Handbüchern.



Schutzkleidung muß immer getragen werden.

Symboles - Français

Les symboles suivants sont utilisés dans ce manuel pour aider à communiquer le but des instructions. Quand l'un de ces symboles apparaît, il évoque le sens défini ci-dessous:



AVERTISSEMENT - De graves lésions corporelles ou des dommages matériels considérables peuvent survenir si les instructions données sous les rubriques "Avertissement" **ne** sont **pas** suivies.



ATTENTION - De petites lésions corporelles peuvent survenir, ou bien une pièce, un ensemble ou le moteur peuvent être endommagés si les instructions données sous les rubriques "Attention" **ne** sont **pas** suivies.
sécurité p



Indique une opération de **DEPOSE**.



Indique une opération de **MONTAGE**.



L'INSPECTION est nécessaire.



NETTOYER la pièce ou l'ensemble.



EFFECTUER une **MESURE** mécanique ou de temps.



GRAISSER la pièce ou l'ensemble.



Indique qu'une **DIMENSION DE CLE** ou **D'OUTIL** sera donnée.



SERRER à un couple spécifique.



S'assurer que les **REPERES D'ÉQUILIBRAGE** sur l'ensemble de rotor sont alignés.



EFFECTUER une **MEASURE** électrique.



Se reporter à un autre endroit dans ce manuel ou à une autre publication pour obtenir des information plus complètes.



Il faut toujours mettre vêtements de protection.

Símbolos - Português

Os símbolos a seguir serão utilizados neste manual para facilitar a comunicação das instruções e seu significado estão descritos abaixo.



ATENÇÃO - Se as instruções não forem seguidas, há possibilidade de ocorrer sérios danos pessoais e materiais.



CUIDADO - Danos aos componentes, ao conjunto ou ao motor, ou mesmo pequenos danos pessoais podem ocorrer se as instruções não forem seguidas..



Indica um passo de **DESMONTAGEM**.



Indica um passo de **MONTAGEM**.



Requer **INSPEÇÃO**.



LIMPE a peça ou conjunto.



Requer **MEDIÇÃO** mecânica ou de tempo.



LUBRIFIQUE a peça ou o conjunto.



Indica necessidade de **APERTO**.



TORQUEAR de acordo com o especificado.



Assegure-se de que as **MARCAS DE BALANCEAMENTO** do conjunto eixo-rotor estejam alinhadas.



Requer medição **ELÉTRICA**.



Procure em outra seção deste manual ou em publicação para obter informações adicionais



Por favor, sempre utilize EPI (Equipamento de Proteção Individual)

Component Identification

Turbocharger Identification

A dataplate is fitted to the compressor housing (8). The information on this dataplate must be quoted for service and parts support.

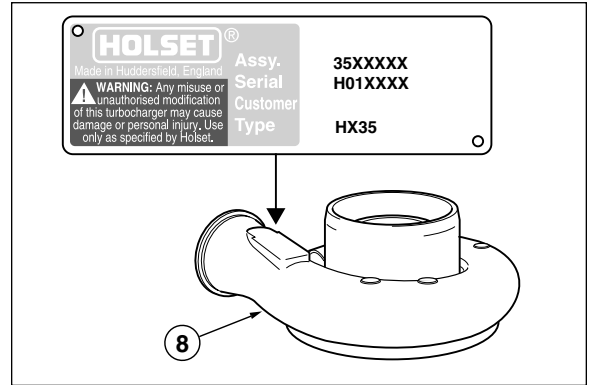

HX30/35/40 - Center Housing Rotating Assembly (C.H.R.A.)

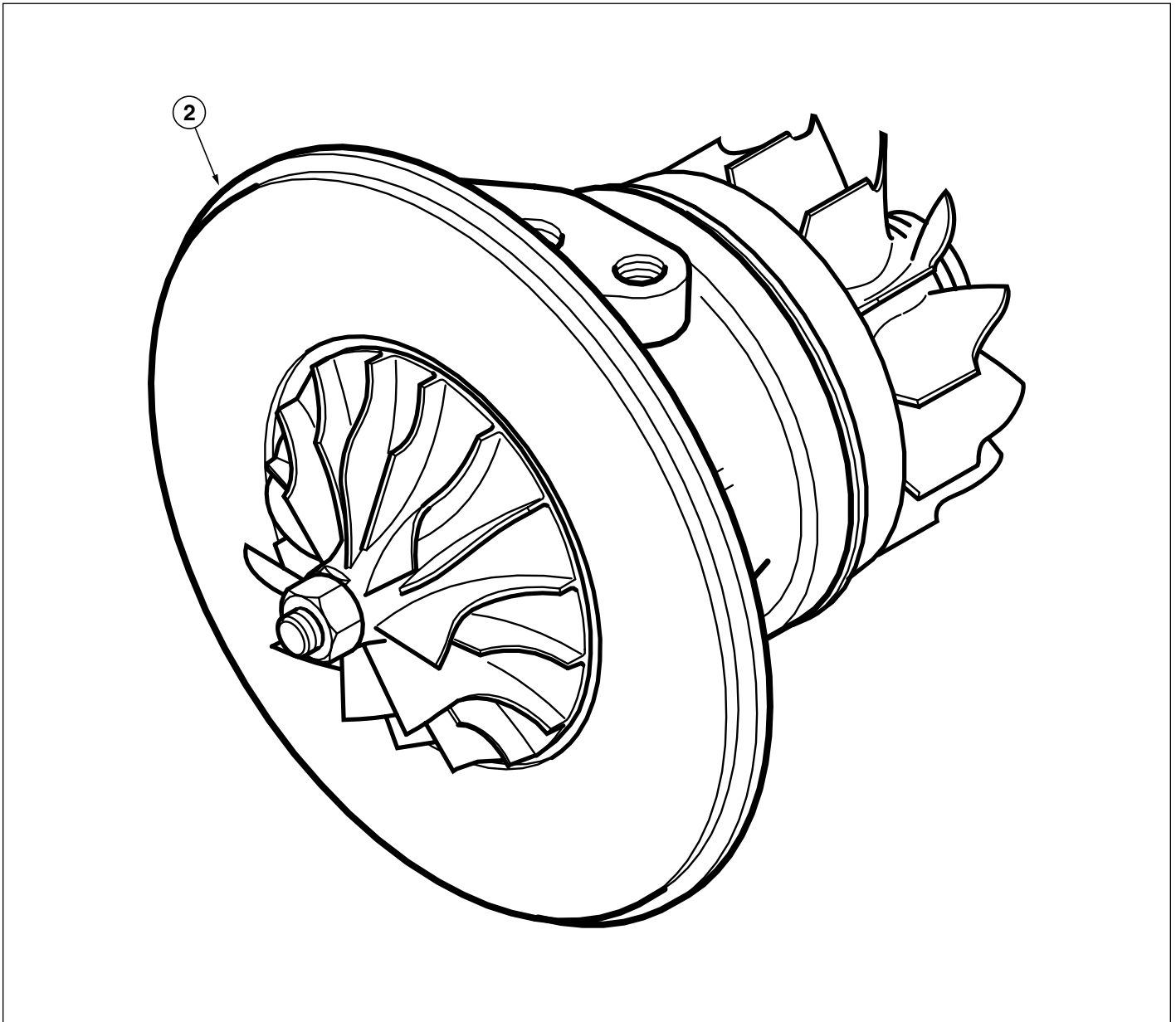

Components - HX35/40

Item No.	Description	Quantity
4	Bearing Housing	1
5	Turbine Housing	1
6	Assembly Turbine Wheel	1
7	Compressor Wheel	1
8	Compressor Housing	1
11	Journal Bearing	1
12	Thrust Bearing	1
13	Piston Ring Seal, Turbine	1
16	Piston Ring Seal, Compressor	1
22	Retaining Ring	1
31	Oil Slinger	1
32	O Ring Seal, Bearing Housing	1
33	Oil Baffle	1
34	Inlet Baffle	1
36	Thrust Collar	1
38	Heat Shield	1
43	Oil Seal Plate	1
57	Bolt, Turbine Housing (HX35/40)	6
61	Locknut, Compressor Wheel	1
64	Ring Retaining Bearing (Snap Ring)	4
66	Insert, Retaining Ring	1
88	Clamp Plate, Turbine Housing (HX35/40)	2
91	Compressor Cover Retaining Ring	1

Exploded View - HX35/40

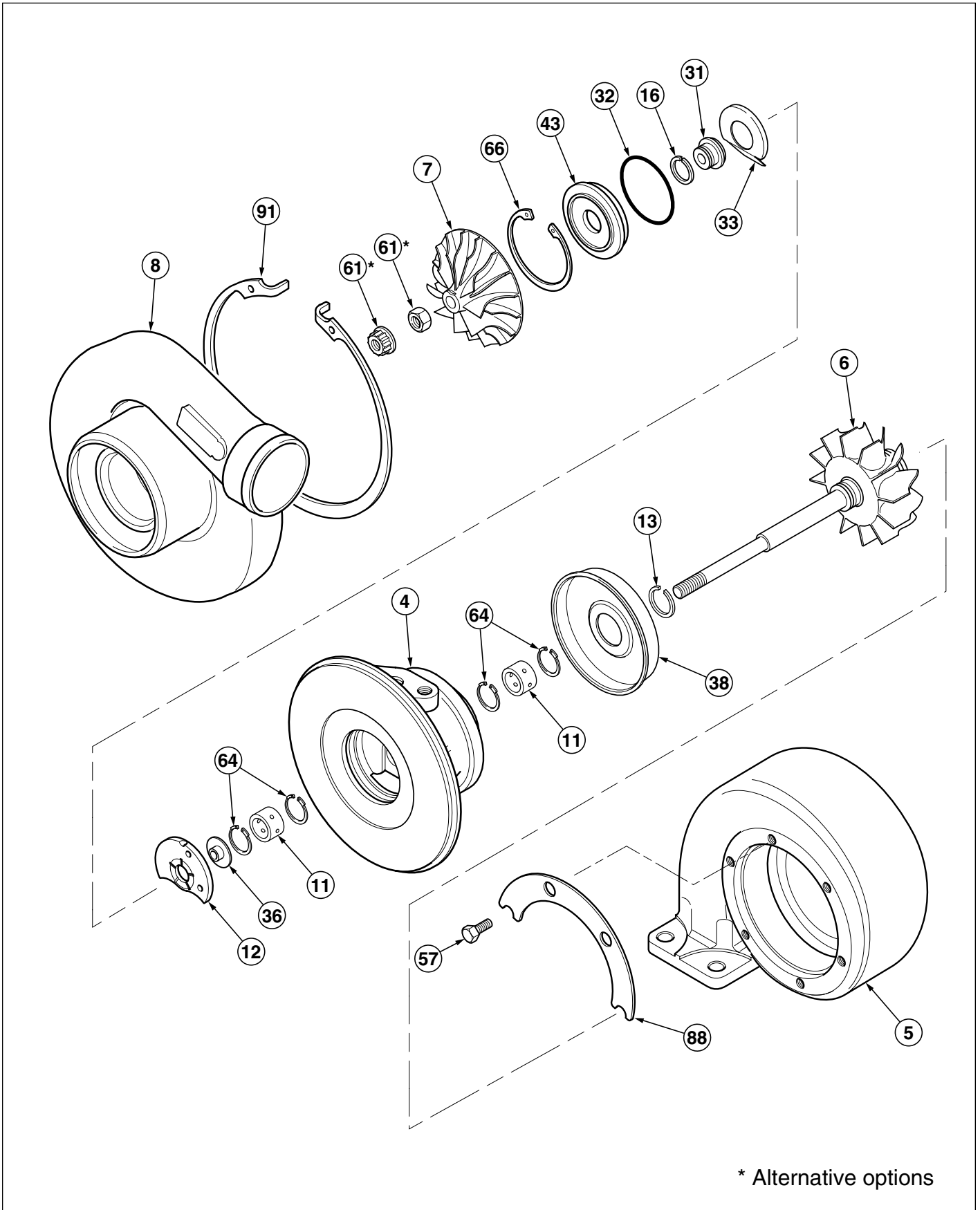

* Alternative options

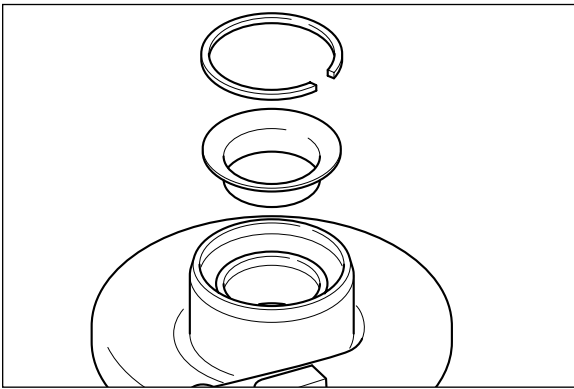

Optional Components

Compressor Inlet Baffle (34) (if fitted)

Where specified by the engine manufacturer, certain turbochargers can have a pressed steel baffle fitted into the inlet section.

This item is **not** serviceable and if damaged, **must** be replaced, as the geometry of the part is critical to the performance of the baffle.

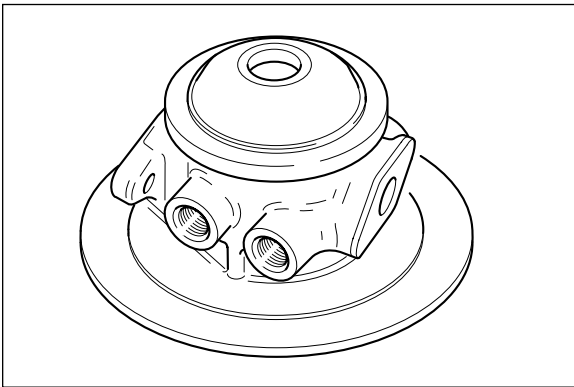

Watercooled Bearing Housing (4) (if fitted)

As with the inlet baffle option, certain engine manufacturers can specify a watercooled bearing housing. These can have additional water feed and drain plug fittings.

Old Style Nut
3503562

New Style Nut
3590306

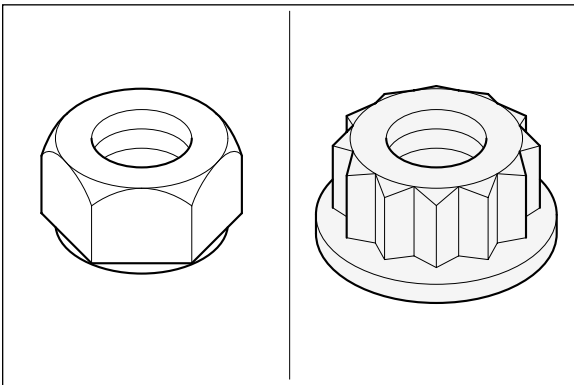

Caution: Always use specified torque. Failure to do so may result in turbocharger / engine failure.

New Compressor Wheel Locknut

Holset have introduced a new compressor wheel lock nut which is to be fitted to all new WH1C/E turbochargers. If your turbo is fitted with the new nut, it indicated that this turbocharger may have been built using the core balance process at point of manufacture rather than the traditional rotor balance process. The new nut will also require a different torque process when rebuilding the turbo after service.

Old Lock Nut Part Number 3503562

Torque value: 17Nm [150lb ins].

New Lock Nut Part Number 3590306

Torque value: 16Nm [142lb ins].

(or shaft stretch of .0006" - .0012")

Always Check there are correlation marks between the Shaft End and the Compressor Wheel before disassembly. If no marks exist, make sure you make your own marks before loosening the compressor wheel lock nut.

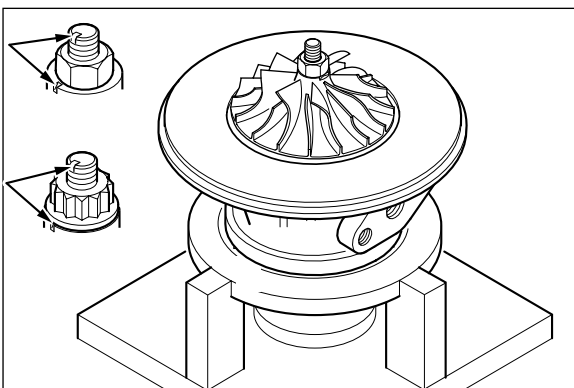

ALWAYS check balance the Rotor before rebuild.

Component Disassembly and Assembly

Service Tools

The following special tools are recommended to perform procedures in this manual. The use of these tools is shown in the appropriate procedure. These tools can be purchased from your local Authorised Repair Location.

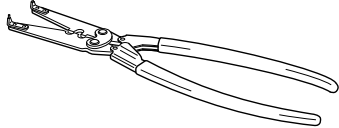
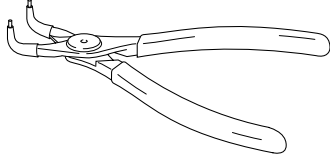
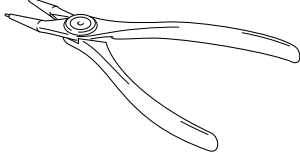
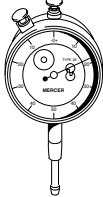
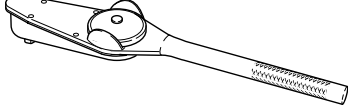
Part No.	Tool Description	Tool Illustration
3575186	Circlip Pliers	
56662	Circlip Pliers	
56664	Circlip Pliers	
	Dial Gauge	
	Torque Wrench	

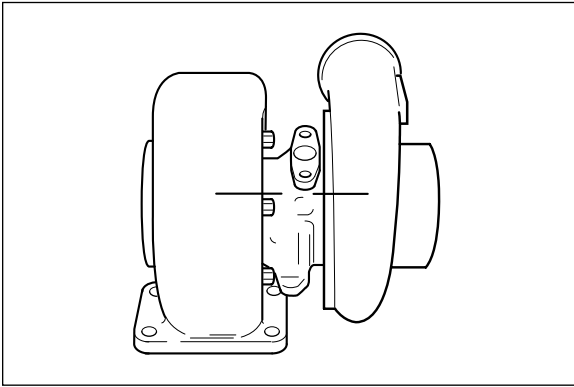

Disassembly

Note: * Denotes a part which is included in the basic overhaul kit.

Before disassembling the turbocharger, scribe the parts listed below to help in alignment during assembly.

- compressor housing (8)
- turbine housing (5)
- bearing housing (4).

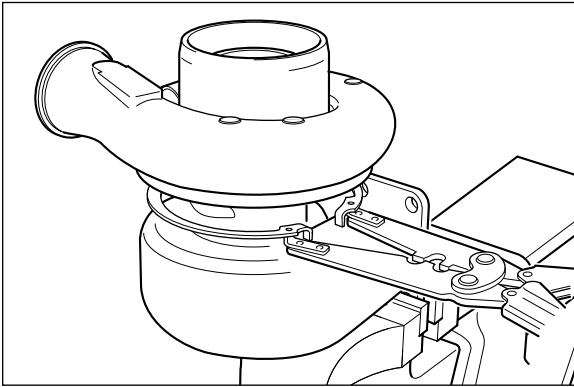

Secure the turbine housing (5) in a vice and remove the compressor cover circlip (91) using circlip pliers, Part No. 3575186.

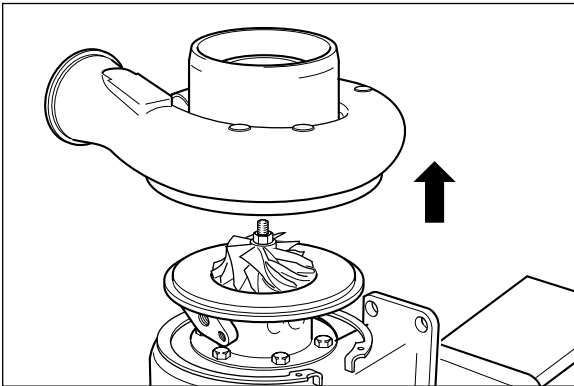

Caution: The compressor wheel blades can be easily damaged when the compressor housing is removed.



Gently remove the compressor cover (8).

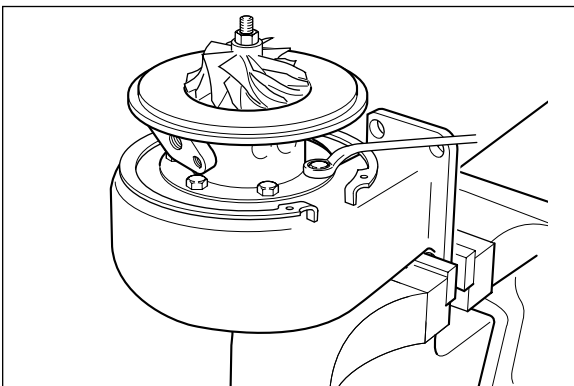

13mm

HX35/40: Loosen and remove the six bolts (57) and clamp plates (88).



Caution: The turbine blades can be easily damaged when the turbine housing is removed.

Remove the C.H.R.A. from the turbine housing.

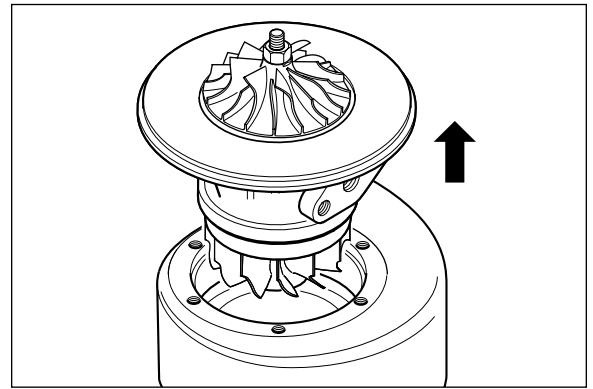

19mm

Caution: (See Page 14)

Locate the C.H.R.A. onto a 19mm socket clamped in the jaws of a vice or a suitable fixture.

Caution: Always make sure the turbine wheel shaft and the compressor wheel have alignment marks before disassembly of the C.H.R.A

If no marks exist, scribe the shaft and compressor wheel (as shown) before removing the compressor wheel locknut.

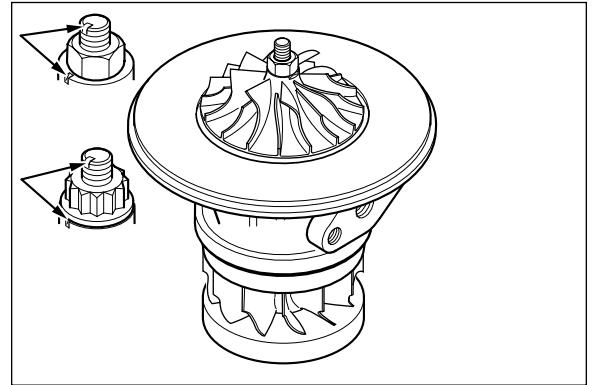
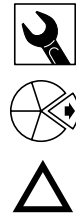

13mm

Caution: (See Page 14)

Remove the compressor wheel lock nut (61*).

Note: Left hand thread

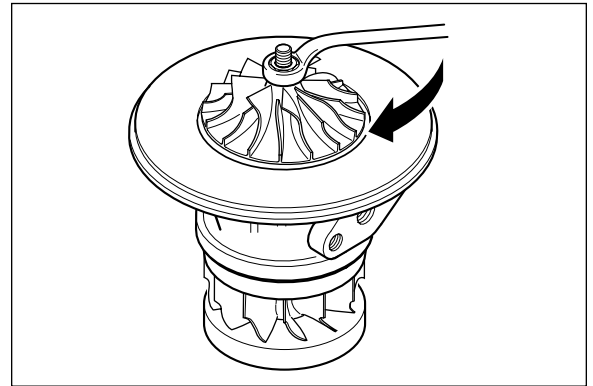
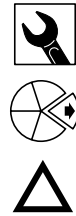

Remove the compressor wheel (7).

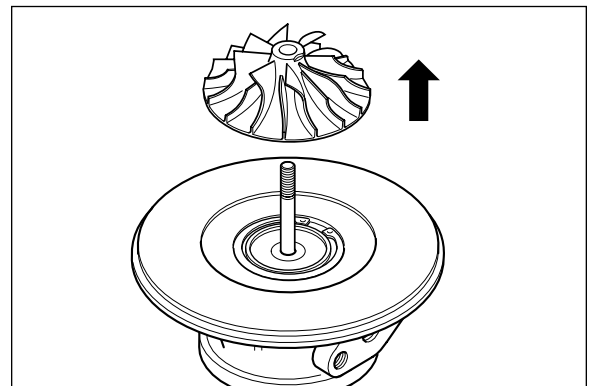
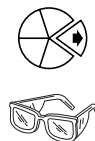

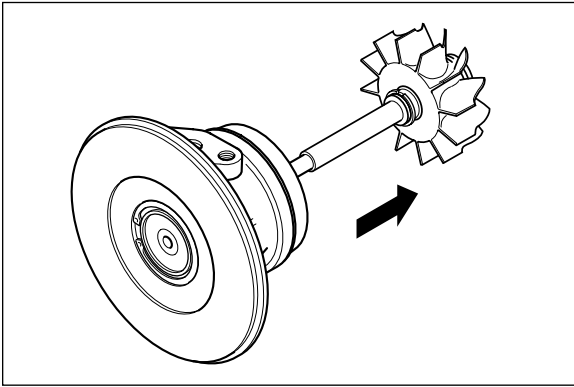

Remove the remaining C.H.R.A. from the socket and gently slide the shaft and wheel (6) from the bearing housing (4).

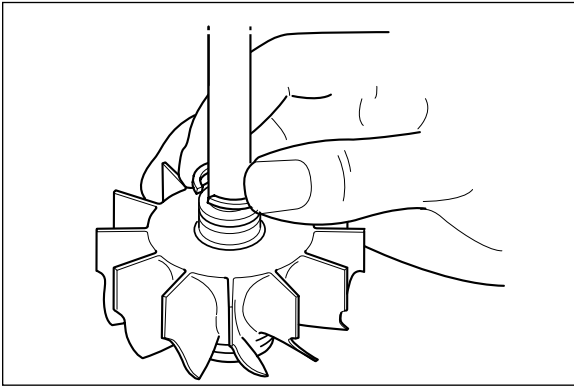

Caution: Care should be taken not to score the assembly turbine wheel shaft.

Carefully remove and discard the piston ring seal (13*).

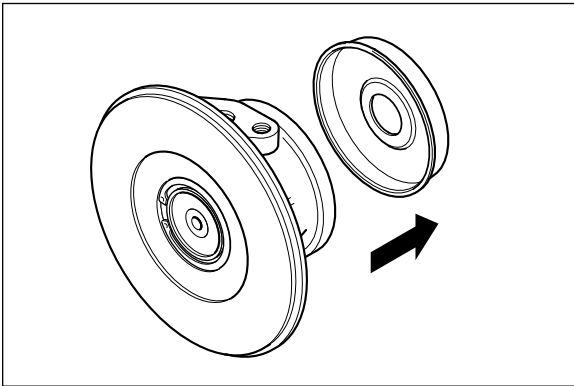

Remove the heat shield (38).

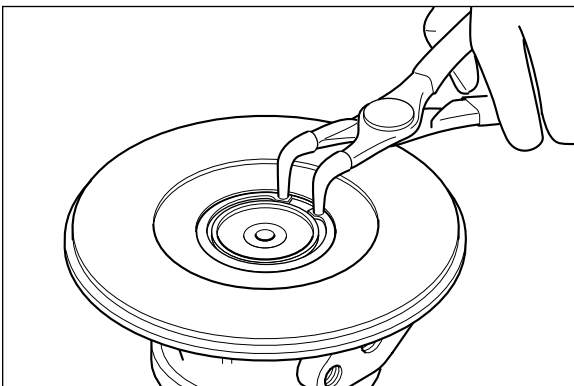

Place the bearing housing on a flat surface and using circlip pliers, Part No. 56662, remove the insert retaining ring (66).



Using two flat nose pliers, gently remove the oil seal plate (43).

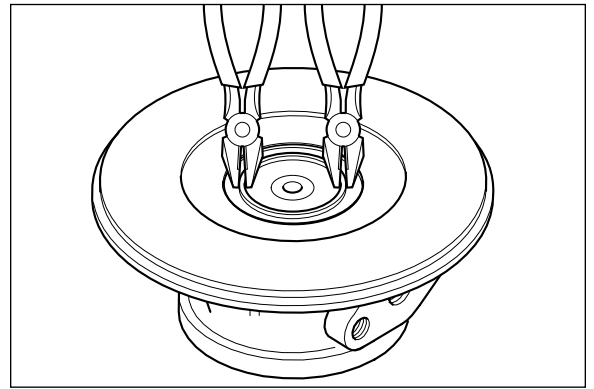

Remove the oil slinger (31).

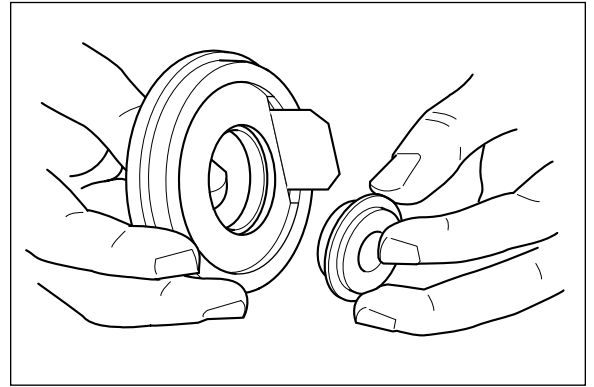

Remove and discard the piston ring seal (16*).

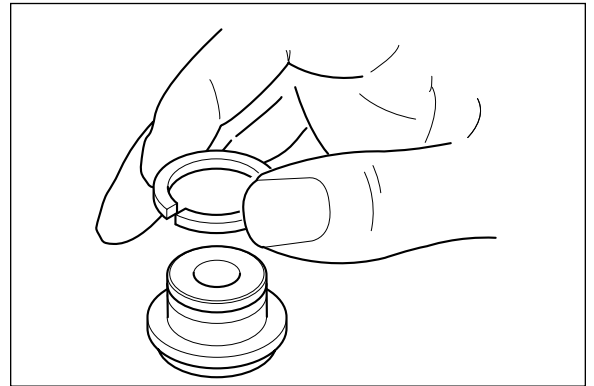

Remove and discard the oil baffle (33*).

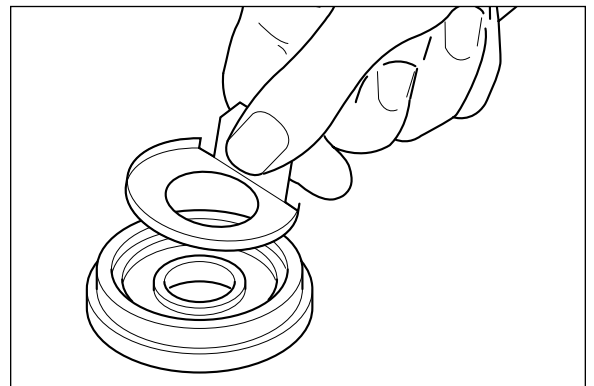

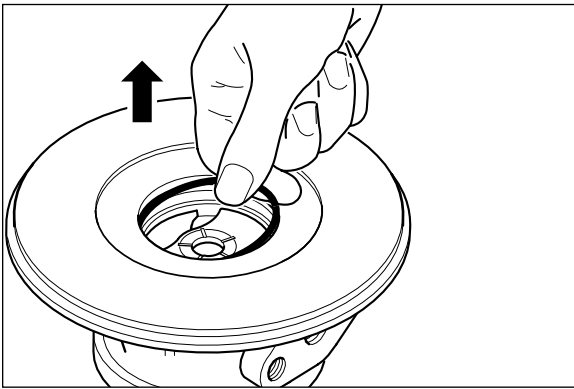

Remove and discard the O-ring seal (32*).

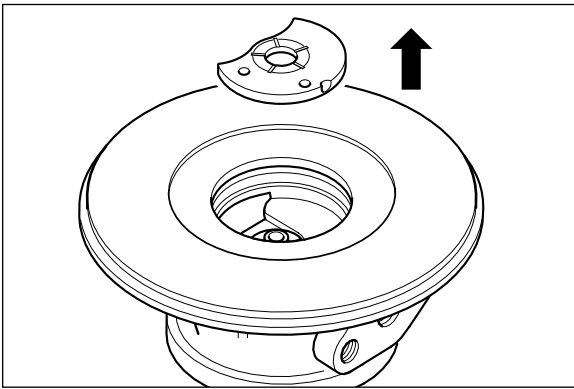

Remove the thrust bearing (12*).

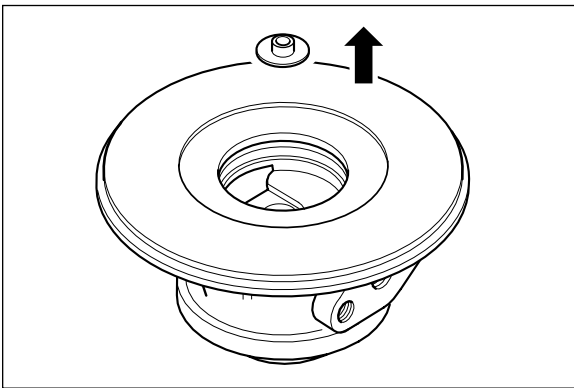

Remove the thrust collar (36).

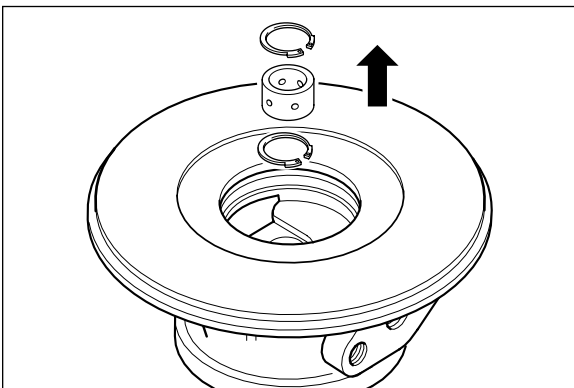

Using circlip pliers, Part No. 56664, remove and discard the two circlips (64*) and the journal bearing (11*) from the compressor end.



Turn the bearing housing over and repeat the process.

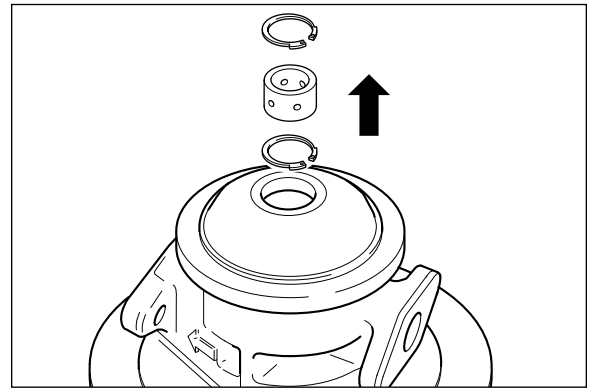

Cleaning

With the turbocharger completely dismantled for overhaul, soak all the components in a non-caustic metal cleaner to loosen deposits. Bead blast the turbine housing if chemicals do **not** clean sufficiently.

On aluminium parts a bristle brush can be used. Never use a wire brush or metal scraper on any turbocharger component. Ensure that all the parts are finally cleaned with an air jet, especially drilled passages and machined apertures. Turbine Wheel: In the event of carbon build-up, it may be necessary so carefully blast the Piston Ring Groove area of the turbine wheel using low grade shot medium.

Caution: Shot Blasting specific areas for long periods of time may effect component balance.

The surface adjacent to the turbine and compressor wheels on the stationary housings **must** be clean, smooth and free from deposits.

Inspection

Caution: Do not attempt to straighten the turbine shaft.

- a) Place the shaft on a vee block, using a dial gauge rotate the turbine wheel and check for movement on the dial gauge. Replace the assembly turbine wheel if it is bent.

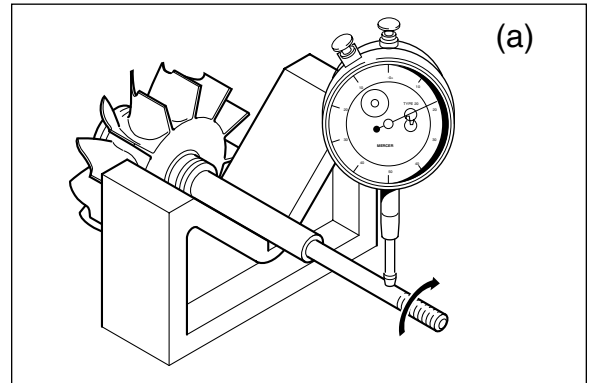

Shaft Bend		
mm		in
0.025	Max	[0.001]

Major Components

Assembly Turbine Wheel (6)

- b) Inspect the piston ring groove walls for wear.

Turbine Wheel Piston Ring Groove		
mm		in
1.664	MIN	[0.0665]

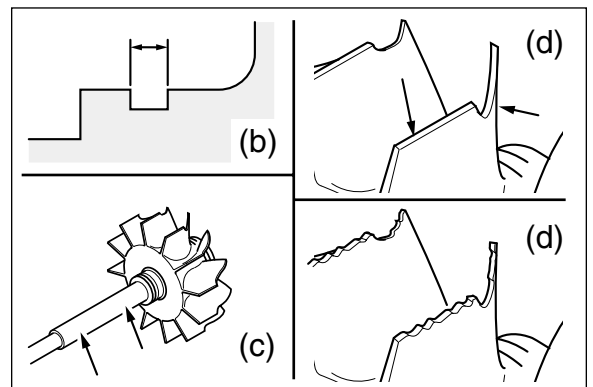

- c) Inspect the bearing journals for excessive scratches and wear. Minor light scratches may be tolerated.

Assembly Turbine Wheel Journals		
mm		in
10.972	MIN	[0.432]

- d) Inspect for cracked, bent or damaged blades but **DO NOT ATTEMPT TO STRAIGHTEN BLADES.**

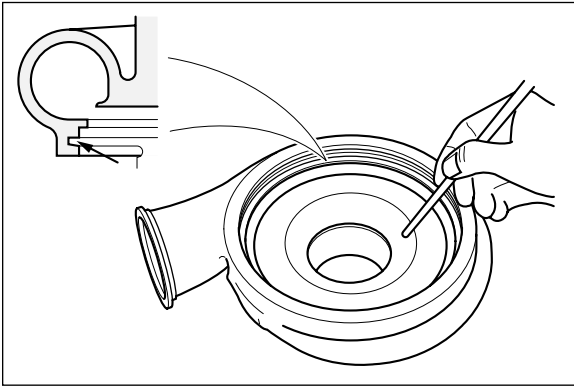

Compressor Housing (8)

Inspect the profile for damage due to possible contact with the rotor. Also check the retaining ring groove area is free from deposits.

Replace with new if any damage is visible.

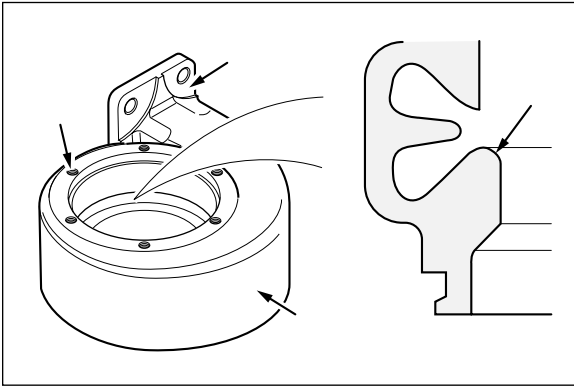

Turbine Housing (5)

Inspect the profile for damage caused by possible contact with the rotor. Check all threads for damage. Inspect the outer and internal walls for cracks or flaking caused by overheating also check mounting flanges for signs of distortion.

Replace with new if any of the above are visible.

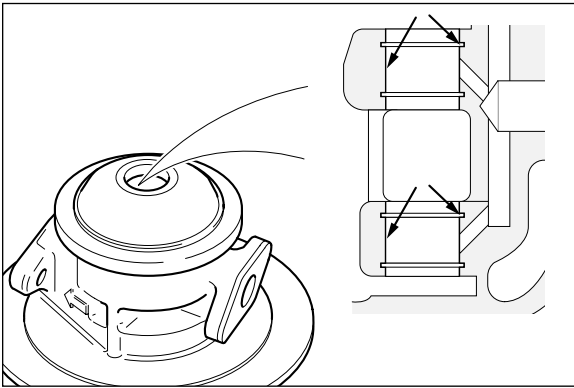

Bearing Housing (4)

Inspect the bore for wear or score marks on both the bearing and piston ring area. Also check all tapped holes are clean and free from dirt.

Replace with new if any damage is found.

Bearing Housing Bore		
mm		in
15.885	MAX	[0.6254]

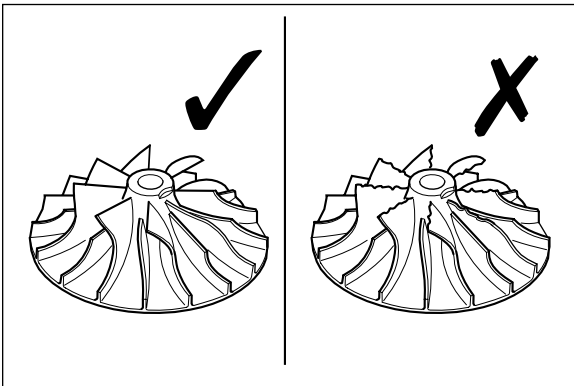

Compressor Wheel (7)

Inspect carefully for cracked, bent or damaged blades but **DO NOT ATTEMPT TO STRAIGHTEN BLADES.**

Replace with new if any damage is found.

Minor Components

Oil Slinger (31)

Inspect and replace if the piston ring seal groove walls are scored or damaged. Also check for signs of rubbing on the flat surfaces.

Groove Width		
mm		in
1.664	MAX	[0.0665]

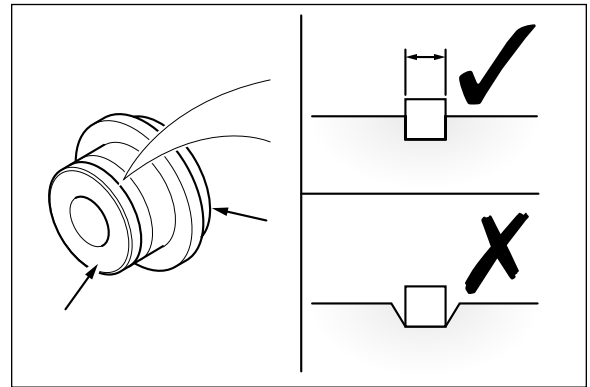

Oil Seal Plate (43)

Inspect the seal bore, replace if scored or damaged.

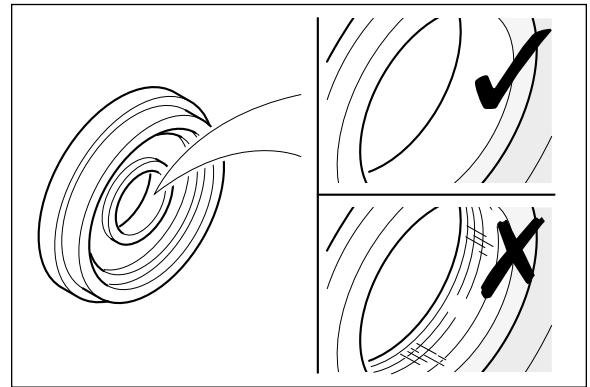

Heat Shield (38)

Check and replace if the heat shield is distorted or if signs of rubbing or cracking are visible.

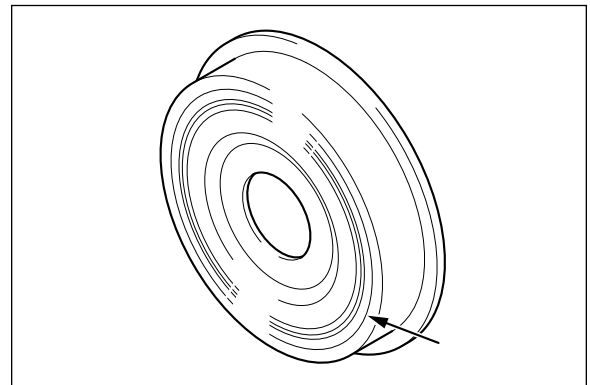

Assembly

Caution: Circlips (64). Premature failure will result if the circlips are fitted incorrectly.

Make sure that the circlips are always fitted with the bevelled edge facing the journal bearing.

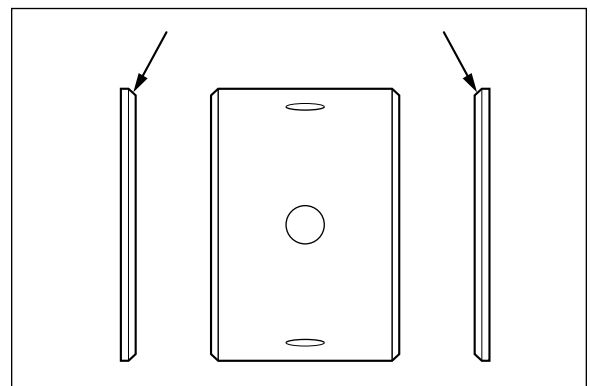

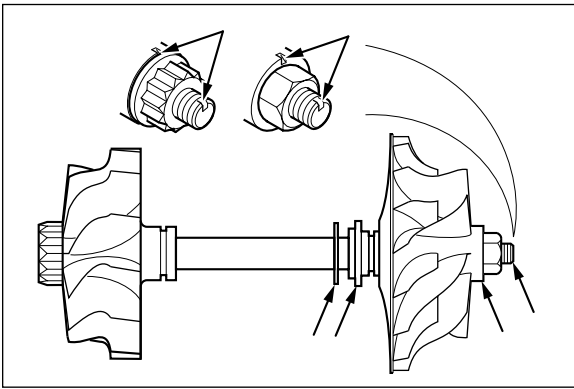

Caution: Balance marks (See Page 14)

Always make sure that the balance marks on the rotor assembly are in alignment when rebuilding the turbocharger.

Make sure that both compressor wheel and assembly turbine wheel are individually check balanced.

Rotor Balance Limits

Turbine End gmm (oz. ins.)	Compressor End gmm (oz. ins.)
1.5gmm (.002)	1.5gmm (.002)

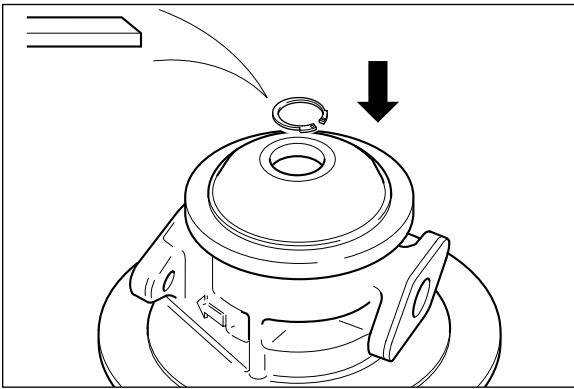

Place the bearing housing (4) on a bench with the turbine end facing uppermost.

Fit the inner circlip (64) with the bevelled edge facing upwards.

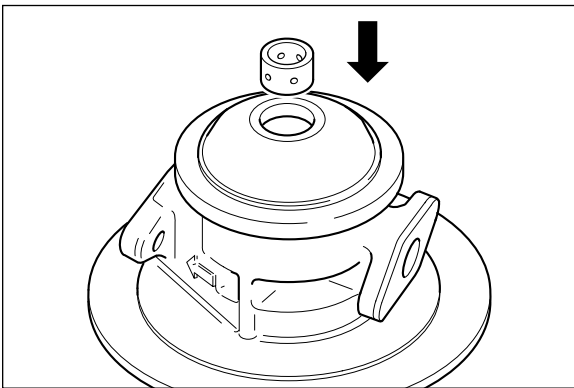

Lubricate the journal bearing (11) and install into position.

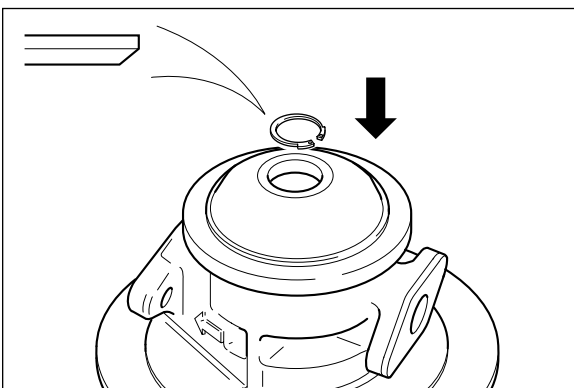

Fit the outer circlip (64) with the bevelled edge facing the bearing.

Turn the bearing housing over and repeat the process.

Install the heat shield (38).

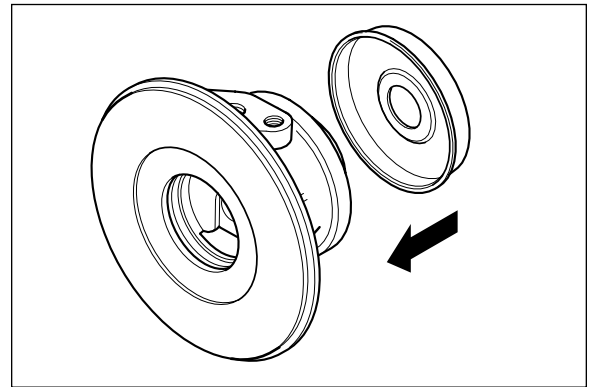

Install the new piston ring seal (16) to the assembly turbine wheel (6).

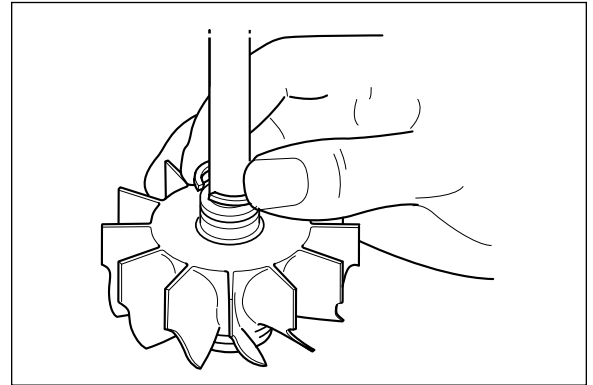

Caution: Align the piston ring seal (16) so the gap is positioned 180° from the oil drain hole. Gently press down on the turbine wheel - a slight rotation of the wheel will assist in properly locating the piston ring seal.

Lubricate the shaft using clean engine oil.

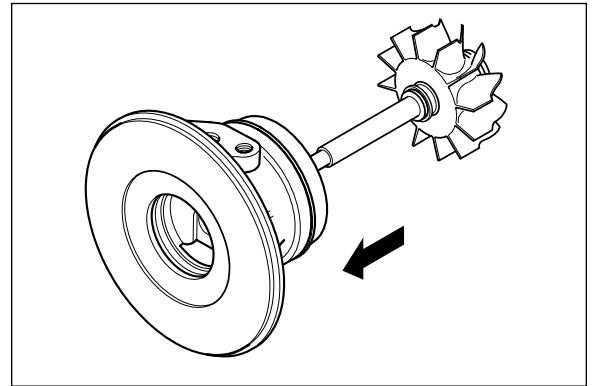

Support the assembly turbine wheel (6) in a suitable fixture.

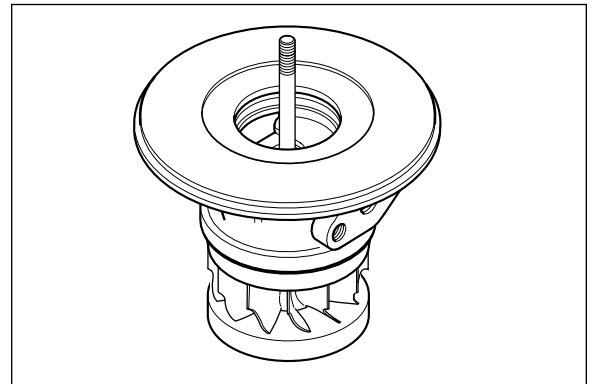

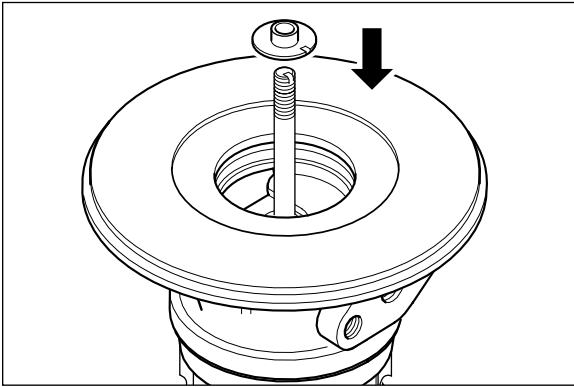

Caution: Align the balance mark on the thrust collar with that on the shaft.

Install the thrust collar (36).

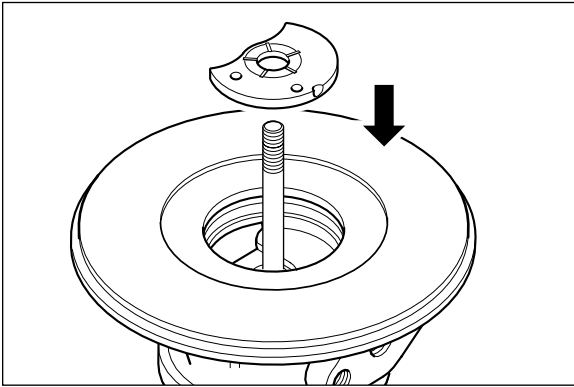

Using clean engine oil, lubricate the thrust bearing (12).

Install the thrust bearing.

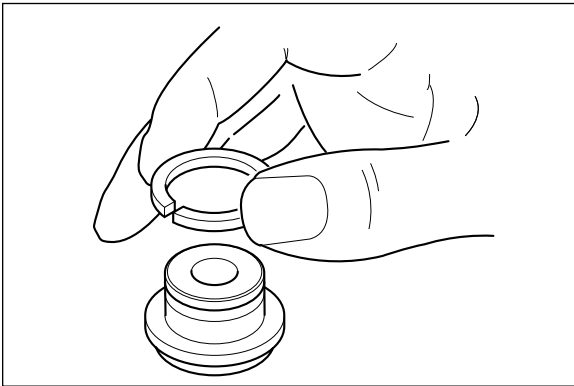

Fit the new piston ring seal (13) to the oil slinger (31).

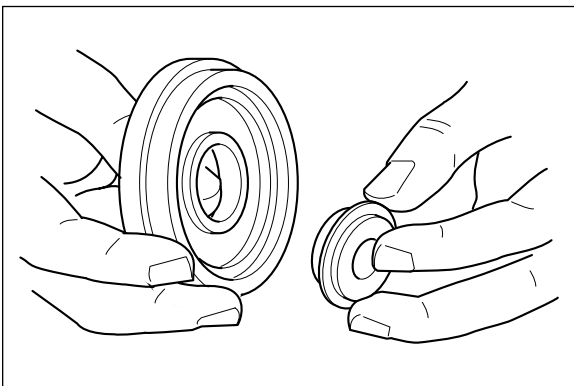

Using clean engine oil, lubricate the oil slinger (31) and install into the oil seal plate (43).

Install the oil baffle (33) into the oil seal plate (43).

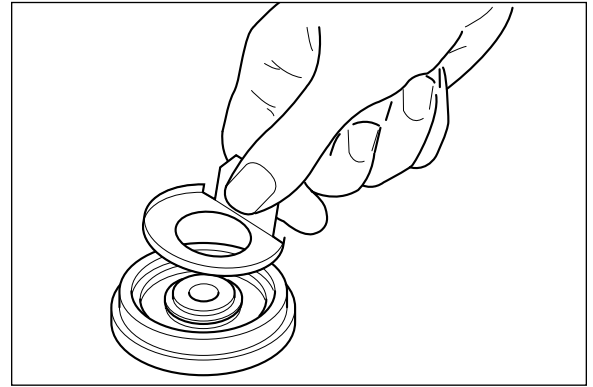

Apply a small amount of engine oil to the oil seal plate (43) and place the O ring seal (32) into position.

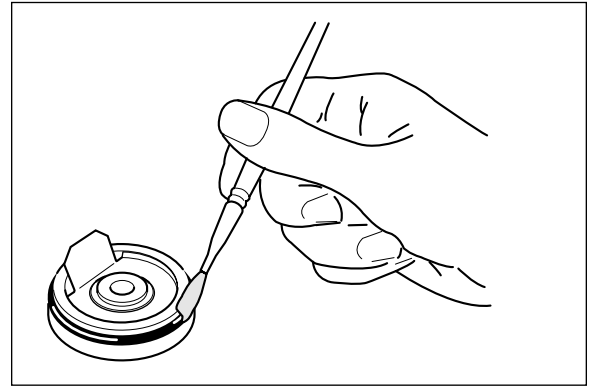

Caution: Align the balance marks on the oil slinger (31) with that on the shaft end.

Install the oil seal plate (43) into the bearing housing (4).

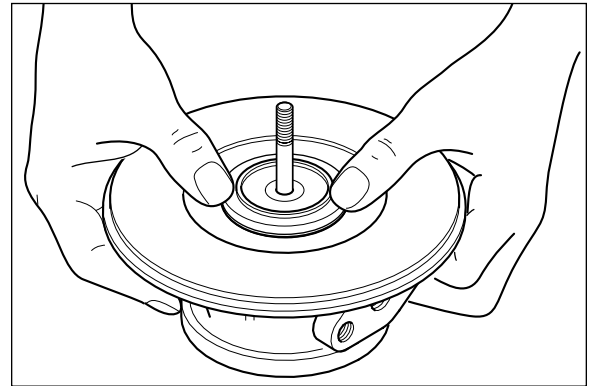

Gently tap the oil seal plate (43) with a soft hammer to seat in position .

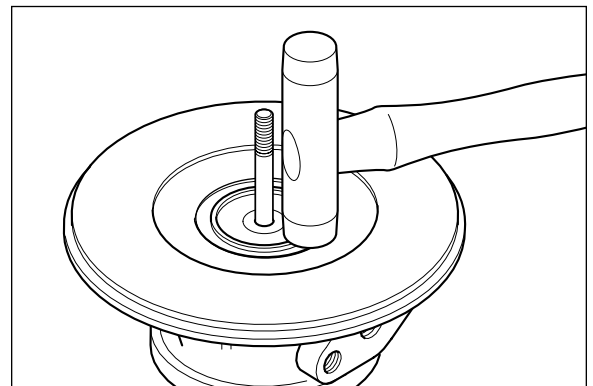

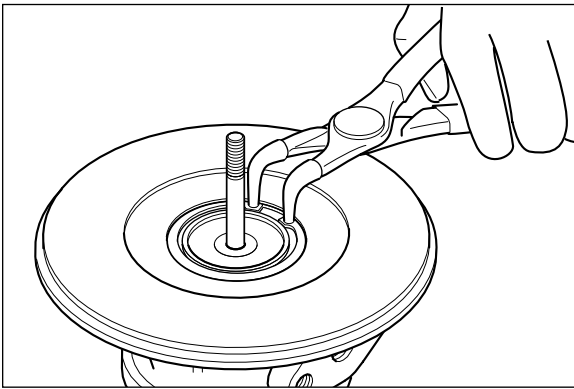

Use circlip pliers, Part No. 56662, to install the retaining ring (66).

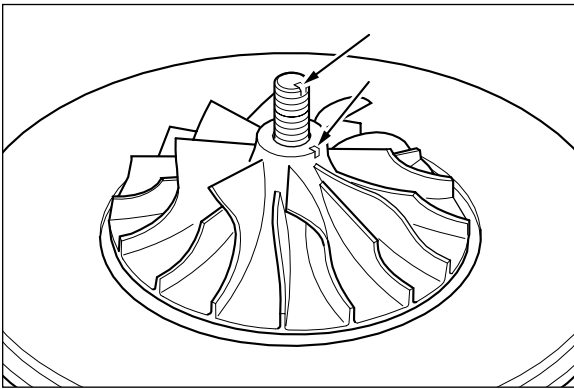

Caution: (See Page 14)

Align the balance marks and install the compressor wheel (7).

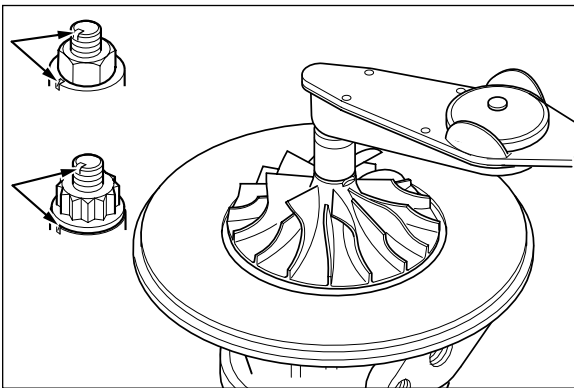

Caution: (See Page 14) Ensure that the balance marks are aligned on the compressor wheel and the shaft.



13mm



Note: Left hand thread.



Install the compressor wheel locknut (61) and tighten to the torque value.

Torque value: 17 Nm [150 in-lbs].

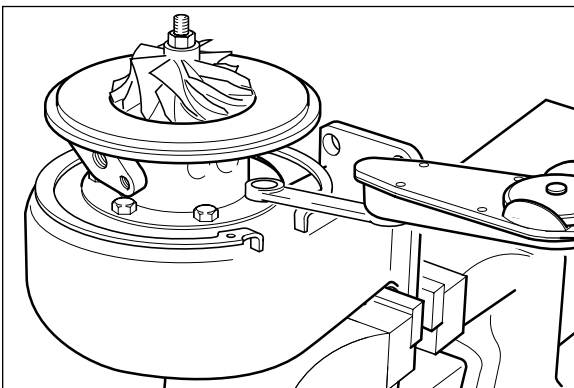

Caution: Make sure the scribe marks are aligned.

13mm



Carefully slide the retaining ring (91) over the assembly turbine wheel (6).



Locate the C.H.R.A. into the turbine housing (5).



HX35/40: Install the two clamp plates (88) and tighten the six bolts (57) to the torque value.

Torque Value: Bolts (57) - 14 Nm [120 in-lbs]

Secure the turbine housing and check the thrust clearance using a dial gauge.

Thrust Clearance		
mm		in
0.038	MIN	[.0015]
0.093	MAX	[.0037]

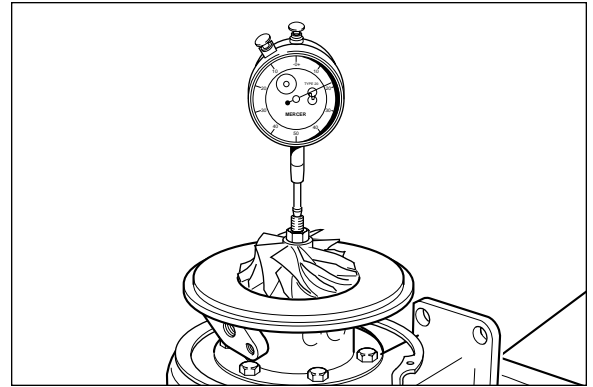

Check the radial clearance using a dial gauge.

Radial Clearance		
mm		in
0.326	MIN	[.0128]
0.496	MAX	[.0195]

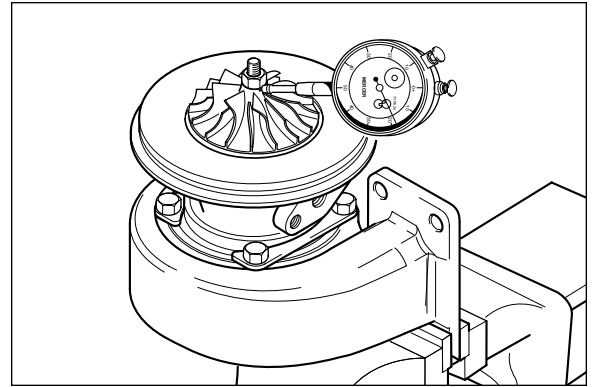

Caution: Make sure the scribe marks are aligned.

Carefully install the compressor cover (8). Using circlip pliers, Part No. 3575186, fit the retaining ring (91).

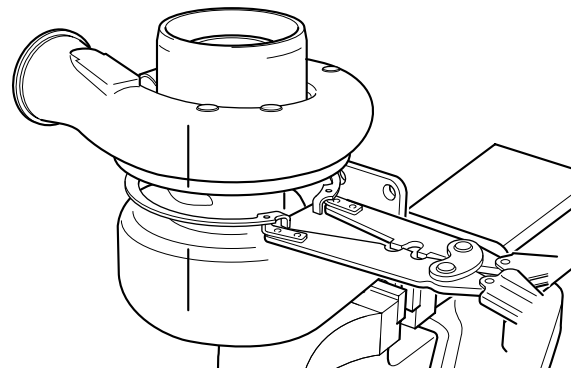

Installation Data

1. Mount the turbocharger on the turbine inlet flange. All other connections must be flexible and heavy pipework should be supported. Always pre-lube with clean engine oil.
2. Always position the bearing housing so that the oil drain is at the bottom and kept within 22° of the vertical centre line when installed on the engine.
3. Oil should be filtered below 15/20 microns. The oil quality must be as specified by the engine manufacturer. e.g. API - CD (MIL - L - 2104C). Improvement in life can be obtained by using super high performance diesel (SPHD) oils, particularly where extended oil drain periods are used.
4. Oil pressure must show at the turbocharger oil inlet within 3 - 4 seconds of engine firing to prevent damage to turbocharger bearing system from lack of lubrication.
5. The minimum oil pressure, when the engine is on load must be 210 kPa [2.0 kgf/cm², 30 lbf/in²] and pressures up to 415 kPa [4.0 kgf/cm², 60 lb/in²] are satisfactory. Under idling conditions the pressure should not fall below 70 kPa [0.7 kgf/cm², 10lbf/in²].
6. The oil inlet pipe should be 9.5 mm [0.375 in.] bore minimum and the oil drain pipe should be 19 mm [0.75 in.] bore minimum. The oil must drain downwards by gravity from the turbocharger into the engine under all operating conditions.
7. Air cleaner pressure drop should not exceed 500 mm [20 in.] of water. Avoid damp/wet air conditions in filter as this can dramatically increase pressure drop on a temporary basis.
8. The exhaust back pressure after the turbocharger should not exceed 500 mm [20 in.] of water. Consult Holset where high restrictions are expected, particularly when exhaust brakes are to be used.

Installation Checklist

1. Always understand why the original turbocharger needs replacing before fitting another unit.
2. Check the turbocharger dataplate to ensure the Part No. is correct for the engine/application.
3. Check the engine intake and exhaust systems are clean and without obstruction ie. free from oil, gasket pieces, dust/dirt/carbon or foreign objects.
4. Replace the oil and air filters using those only recommended by the equipment manufacturer.
5. Change the engine oil using the type specified by the engine manufacturer. A minimum of CD oil is needed for the turbocharger diesel engine.
6. Check that the turbocharger oil inlet and drain connections are clean and free from obstruction and will not leak under pressure.
7. Mount the turbocharger on the exhaust flange and check that the turbine inlet gasket fits properly without obstructing the gas passages.
8. Rotate the turbocharger central bearing housing (4) so that the oil inlet and drain are in the vertical position. Up to 22 Degrees from vertical is permitted.
9. Pour some clean engine oil into the turbocharger oil inlet hole and twist the turbocharger rotor assembly until clean oil starts to flow out of the oil drain flange.
10. Rotate the compressor housing (8) into the correct position and assemble the air intake and boost outlet connections. Check that the connections are well made and do not have a possibility of leaking under pressure.
11. Assemble the exhaust system to the turbine housing outlet (5). Check that the gasket/connection is well made and will not leak in use.
12. Check the exhaust system is well supported and not causing excess loads on the turbocharger. Fit any supports/brackets back in position.
13. Check all hose/pipe clamps/studs/nuts are correctly torqued.
14. Carefully assemble the turbocharger oil inlet pipe and check that the connection is clean, well made and will not leak under pressure.
Do NOT use liquid gasket substances as any excess will enter the turbocharger oil system and obstruct oil flow damaging the turbocharger bearing system in use.
15. Crank the engine WITHOUT firing (engine/fuel pump stop out) until engine oil flows out of the turbocharger drain flange.
16. Assemble the oil drain pipe and check that the connection is well made without obstruction.
17. Check that the engine fuel injection system is correctly regulated as per the manufacturers specifications.
18. Start the engine and leave ticking over at idle for approx. 1 minute so that the oil supply system is fully operational including the new filter(s).
19. Accelerate the engine and check that there are no leaks/obstructions of the air/oil/gas under pressure.
20. Check that the hoses/connections do not deform under normal operation.
21. Before switching off the engine, leave it ticking over at idle for at least 1 minute to cool the turbine.