



Hydraulic Motor/Pump

Series F11/F12
Fixed Displacement



parker.com/pmde



ENGINEERING YOUR SUCCESS.

Basic formulas for hydraulic motors

Flow (q)

$$q = \frac{D \times n}{1000 \times \eta_v} \text{ [l/min]}$$

D - displacement [cm³/rev]

n - shaft speed [rpm]

η_v - volumetric efficiency

Torque (M)

$$M = \frac{D \times \Delta p \times \eta_{hm}}{63} \text{ [Nm]}$$

Δp - differential pressure [bar]
(between inlet and outlet)

η_{hm} - mechanical efficiency

η_t - overall efficiency

($\eta_t = \eta_v \times \eta_{hm}$)

Power (P)

$$P = \frac{q \times \Delta p \times \eta_t}{600} \text{ [kW]}$$

Basic formulas for hydraulic pumps

Flow (q)

$$q = \frac{D \times n \times \eta_v}{1000} \text{ [l/min]}$$

D - displacement [cm³/rev]

n - shaft speed [rpm]

η_v - volumetric efficiency

Torque (M)

$$M = \frac{D \times \Delta p}{63 \times \eta_{hm}} \text{ [Nm]}$$

Δp - differential pressure [bar]
(between inlet and outlet)

η_{hm} - mechanical efficiency

η_t - overall efficiency

($\eta_t = \eta_v \times \eta_{hm}$)

Power (P)

$$P = \frac{q \times \Delta p}{600 \times \eta_t} \text{ [kW]}$$

Conversion factors

1 kg.....	2.20 lb
1 N.....	0.225 lbf
1 Nm.....	0.738 lbf ft
1 bar.....	14.5 psi
1 l.....	0.264 US gallon
1 cm ³	0.061 cu in
1 mm.....	0.039 in
1°C.....	⁵ / ₉ (°F-32)
1 kW.....	1.34 hp

Conversion factors

1 lb.....	0.454 kg
1 lbf.....	4.448 N
1 lbf ft.....	1.356 Nm
1 psi.....	0.068948 bar
1 US gallon.....	3.785 l
1 cu in.....	16.387 cm ³
1 in.....	25.4 mm
1 °F.....	⁹ / ₅ °C + 32
1 hp.....	0.7457 kW



WARNING – USER RESPONSIBILITY

FAILURE OR IMPROPER SELECTION OR IMPROPER USE OF THE PRODUCTS DESCRIBED HEREIN OR RELATED ITEMS CAN CAUSE DEATH, PERSONAL INJURY AND PROPERTY DAMAGE.

This document and other information from Parker-Hannifin Corporation, its subsidiaries and authorized distributors provide product or system options for further investigation by users having technical expertise.

The user, through its own analysis and testing, is solely responsible for making the final selection of the system and components and assuring that all performance, endurance, maintenance, safety and warning requirements of the application are met. The user must analyze all aspects of the application, follow applicable industry standards, and follow the information concerning the product in the current product catalog and in any other materials provided from Parker or its subsidiaries or authorized distributors.

To the extent that Parker or its subsidiaries or authorized distributors provide component or system options based upon data or specifications provided by the user, the user is responsible for determining that such data and specifications are suitable and sufficient for all applications and reasonably foreseeable uses of the components or systems.

Offer of Sale

Please contact your Parker representation for a detailed "Offer of Sale".

General product information

General information and design, Bearing life, F11/F12 Fan motors, F11/F12 in saw motor applications, Parker Power Boost

General product information

Pages 4 - 7

1

Series F11

Bent axis piston pump/motor with fixed displacement

F11

Pages 8 - 38

2

Series F12

Bent axis piston pump/motor with fixed displacement

F12

Pages 39 - 59

3

Accessories

Flushing valves, FV13 flushing valve block, Integrated pressure relief valve, SR pressure relief/anticavitation valve block, SV pressure relief valve block, Speed sensor, BLA Boost units

Accessories

Pages 60 - 68

4

Installation and start up information

F11, F12

Installation and start up information

Pages 69 - 71

5

Change History for edition 2019

Pages 27 and 29: Plug dimension for Main port A and B.
 Pages 27 and 29: Plug dimension for drain port C and D.
 Page 45: Ordering code 00 deleted. F12-250 prepared for speed sensor
 Pages 48 and 54: Port for speed sensor shown plugged.
 Page 66: New **MV** Anti-cavitation valve / make up valve block.
 Page 67: New speed sensor data

Hydraulic motor/pump
Series F11/F12

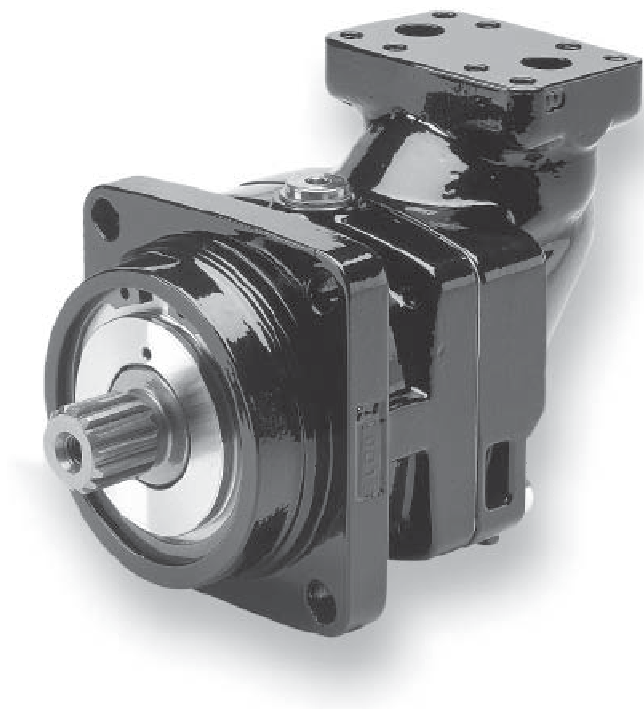
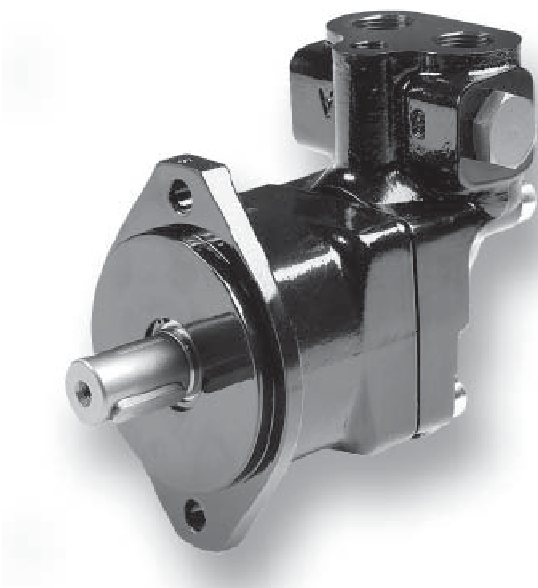

Bearing life

General information

Bearing life can be calculated for that part of the load/ life curve (shown below) that is designated 'Bearing fatigue'. 'Rotating group fatigue and wear' and 'Other' caused by material fatigue, fluid contamination, etc. should also be taken into consideration when estimating the service life of a motor/pump in a specific application.

Bearing life calculations are mainly used when comparing different frame sizes. Bearing life, designated B_{10} (or L_{10}), is dependent of system pressure, operating speed, external shaft loads, fluid viscosity in the case, and fluid contamination level.

The B_{10} value means that 90% of the bearings survive, at a minimum, the number of hours calculated. Statistically, 50% of the bearings will survive at least five times the B_{10} life.

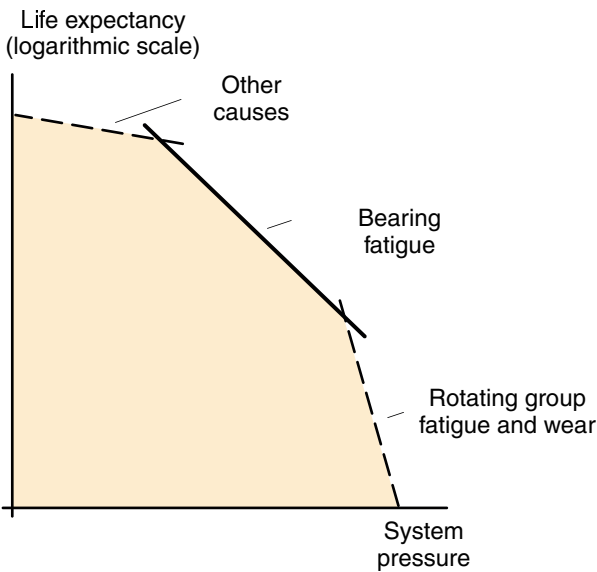

Hydraulic unit life versus system pressure.

Bearing life calculation

An application is usually governed by a certain duty or work cycle where pressure and speed vary with time during the cycle.

In addition, bearing life depends on external shaft forces, fluid viscosity in the case and fluid contamination.

Parker Hannifin has a computer program for calculating bearing life and will assist in determining F11 or F12 motor/pump life in a specific application.

Required information

When requesting a bearing life calculation from Parker Hannifin, the following information (where applicable) should be provided:

- A short presentation of the application
- F11 or F12 size and version
- Duty cycle (pressure and speed versus time at given displacements)
- Low system pressure
- Case fluid viscosity
- Life probability (B_{10} , B_{20} , etc.)
- Operating mode (pump or motor)
- Direction of rotation (L or R)
- External shaft loads (Forces, Gear, Belt, Cardan or none)

For forces please provide:

- Axial load, Fixed radial load, Bending moment, Rotating radial load and distance flange to radial load.

For Gear please provide:

- Pitch diameter, Pressure angle, Spiral angle, Distance flange – gearwheel (mid) and Gearwheel spiral direction (R or L).

For Belt please provide:

- Pretension, Coefficient of friction, Angle of contact, Distance flange – pulley (mid) and Diameter pulley.

For Cardan please provide:

- Shaft angle, Distance flange – first joint and distance between joints
- Angle of attack (α) as defined below

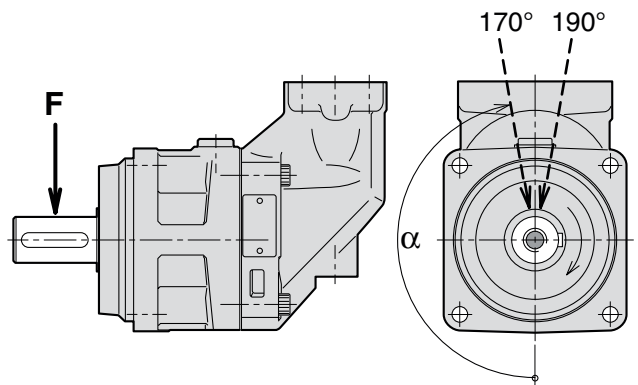

The direction (α) of the radial load is positive in the direction of rotation as shown.

To obtain maximum bearing life, the radial load should, in most cases, be located between 170° and 190°.

F11/F12 Fan motors

F11/F12 motors, in frame sizes -5 to -40 cc, are common in Fan applications. Some typical options are, built in check valve, pressure relief valve, cartridge flange and tapered shaft (refer to the schematic to the right).

The fan motor can be operated at very high speeds without reliability problems. The fan is usually installed directly on the motor shaft without additional bearing support. The F11/F12 has up to 95% overall efficiency which reduces the diesel consumption and minimizes the cooling demand.

Fan motor circuit

Because of the built-in anti cavitation valve, either left hand (L) or right hand (R) rotation must be specified when ordering the motor.

When the pump flow to the motor is shut off and the motor is operating at very high speeds, it is important that sufficient return port back pressure is available (port B in the schematic to the right).

The anti cavitation valve will then open and direct flow to the motor inlet port. If the inlet pressure is insufficient, motor cavitation will be experienced.

In an open circuit, back pressure can be created by a counter pressure valve installed in the return line; preferably, it should be pilot operated to minimize power losses. A back pressure of about 10 bar is sufficient in most applications.

For more drawings illustrating motors with make-up valve, see chapters 2, F11 and 3, F12.

For more info about integrated pressure relief valves, see page 63.

Example of ordering code

F11-010-MB-CV-K-000-MUVL-00

MUVL = Make up/anti cavitation valve, counter clockwise rotation

MUVR = Make up/anti cavitation valve, clockwise rotation

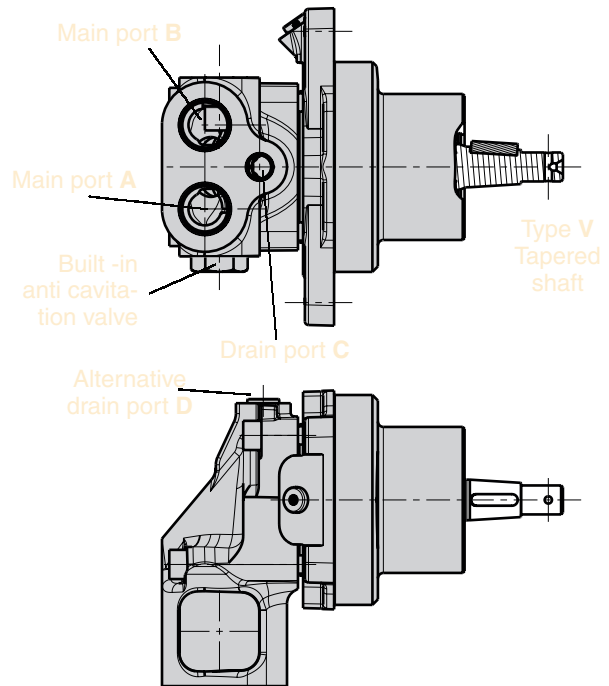

Fan motor (F11-10 left hand rotated shown).

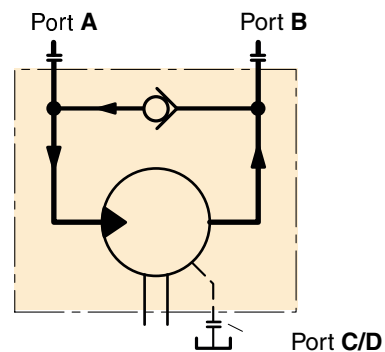

Schematic Fan motor with anti cavitation valve

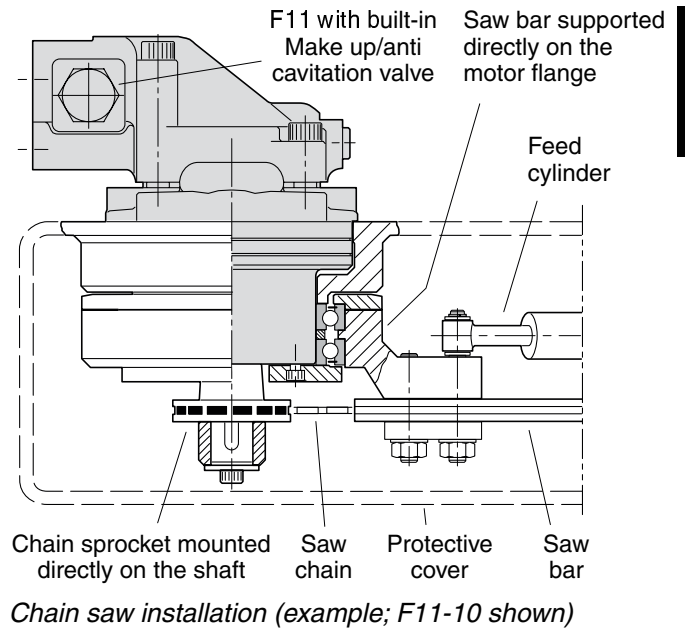

F11



Content	Page
Specifications	9
Efficiency	10
Noise level	10
Selfpriming speed and required inlet pressure	11
Ordering codes	
F11-CETOP	12
F11-ISO	13
F11-SAE	14
Installation dimensions CETOP	
F11-005	15
F11-006, -010	16
F11-012	18
F11-014	20
F11-019	22
Installation dimensions ISO	
F11-006, -010	24
F11-012	26
F11-014	28
Installation dimensions SAE	
F11-006, -010	30
F11-012	32
F11-014	34
F11-019	36

Frame size F11	-005	-006	-010	-012	-014	-019
Displacement [cm ³ /rev]	4.9	6.0	9.8	12.5	14.3	19.0
Operating pressure						
max intermittent ¹⁾ [bar]	420	420	420	420	420	420
max continuous [bar]	350	350	350	350	350	350
Motor operating speed [rpm]						
max intermittent ¹⁾	14 000	11 200	11 200	10 300	9 900	8 900
max continuous ³⁾	12 800	10 200	10 200	9 400	9 000	8 100
min continuous	50	50	50	50	50	50
Max pump selfpriming speed ²⁾						
L or R function; max [rpm]	4 600	–	4 200	3 900	3 900	3 500
Motor input flow						
max intermittent ¹⁾ [l/min]	69	67	110	129	142	169
max continuous [l/min]	63	61	100	118	129	154
Drain temperature ³⁾ , max [°C]	115	115	115	115	115	115
min [°C]	-40	-40	-40	-40	-40	-40
Theoretical torque at 100 bar [Nm]	7.8	9.5	15.6	19.8	22.7	30.2
Mass moment of inertia						
(x10 ⁻³) [kg m ²]	0.16	0.39	0.39	0.40	0.42	1.1
Weight [kg]	4.7	6.5	6.5	7.5	7.5	11

1) Intermittent: max 6 seconds in any one minute.

2) Selfpriming speed valid at sea level. Find more info on page 11

3) See also installation information. Page 69

Efficiency

Because of its high overall efficiency, driving a motor/pump from series F11 requires less fuel or electric power. Also, it allows the use of a small reservoir and heat exchanger, which in turn reduce cost, weight, and installation size.

The diagrams to the right show volumetric and mechanical efficiencies of an F11-5 motor.

F11-19 motors can be equipped with Power Boost which in high speed applications can decrease the mechanical losses by up to 15%, see page 7.

Contact Parker Hannifin for efficiency information on a particular F11 frame size that is being considered.

Noise level

Series F11 feature low noise levels from low to high speeds and pressures.

The noise level is measured in a semi-anechoic room, 1 m behind the unit. As an example, the diagram to the right shows the noise level of an F11-005.

The noise level for a particular motor/pump may vary ± 2 dB(A) compared to what is shown in the diagram.

NOTE: Noise information for F11/F12 frame sizes are available from Parker Hannifin.

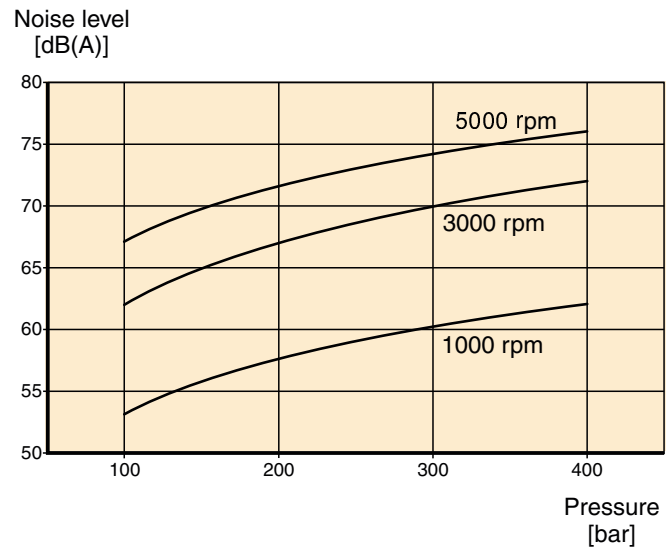
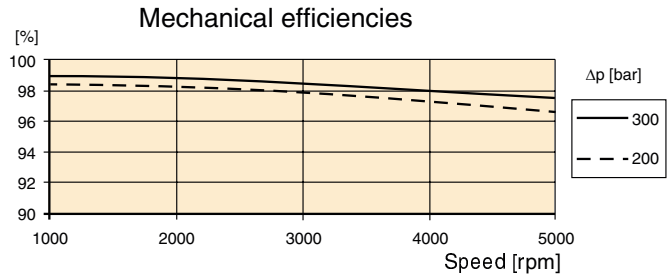
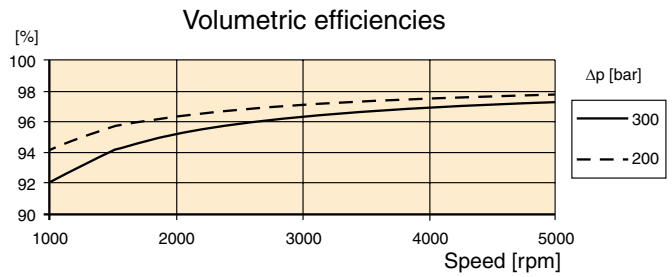

Selfpriming speed and required inlet pressure

Series F11

In pump applications, the F11 with function **L** (counter clockwise rotation) or **R** (clockwise rotation) is normally used. The L and R (pump) provide the highest self priming speeds (see table) as well as the lowest noise level. The **M** and **H** (motor) function can also be used as a pump, in either direction, but at a lower self priming speed.

Operating above the self priming speed (refer to Diagram 1) requires increased inlet pressure. As an example, at least 1.0 bar is needed when operating the F11-19-M as a pump at 3500 rpm. An F11 used as a motor (e.g. in a hydrostatic transmission), may sometimes operate as a pump at speeds above the self priming speed; this requires additional inlet pressure. Insufficient inlet pressure can cause pump cavitation resulting in greatly increased pump noise and deteriorating performance.

Function	L or R	M	H
F11-5	4600	3800	3200
F11-6		3100	
F11-10	4200	3100	2700
F11-12	3900	-	3000*
F11-14	3900	-	3000*
F11-19	3500	2400	2100

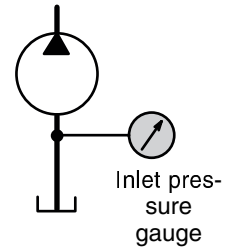

* Valve plate S

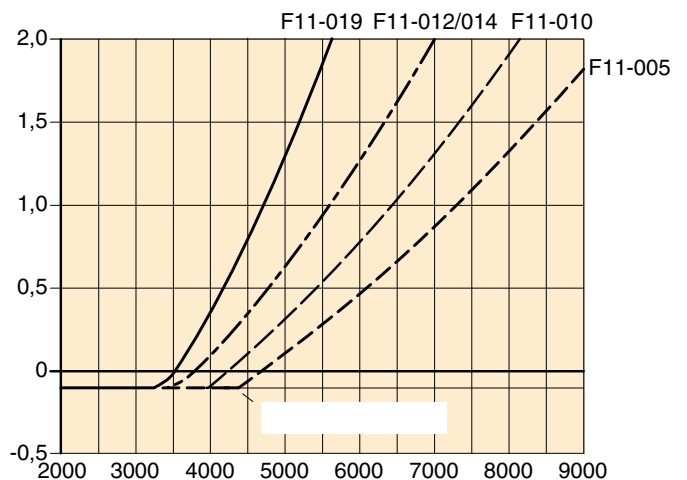
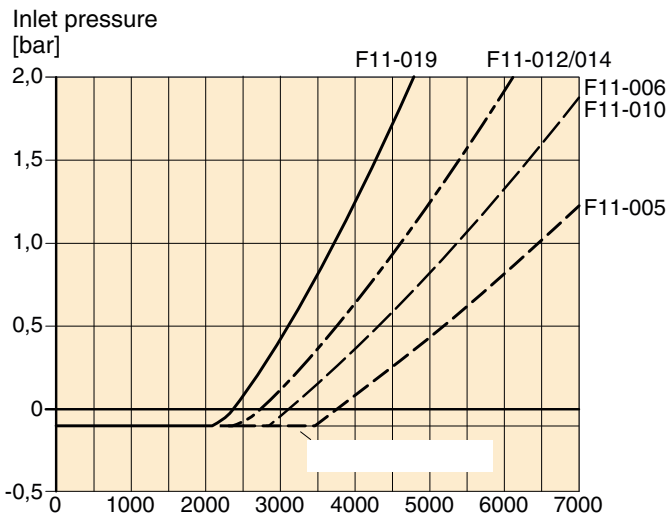

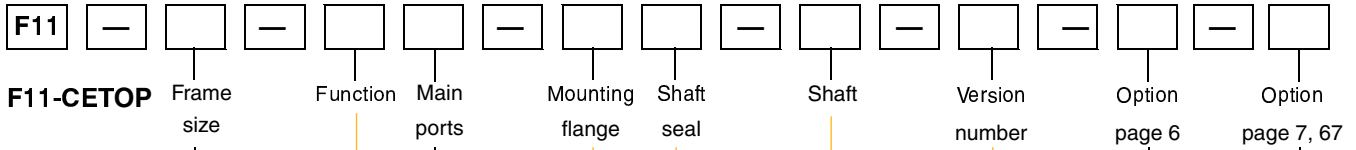

Frame size	
Code	Displacem. (cm ³ /rev)
005	4.9
006	6.0
010	9.8
012	12.5
014	14.3
019	19.0

Version number
(assigned for special versions)

Frame size		5	6	10	12	14	19
Code	Option						
0000	Standard	x	x	x	x	x	x
MUVR	Make up/Anti cavitation valve clockwise rotation	-	(x)	(x)	(x)	(x)	(x)
MUVL	Make up/Anti cavitation valve counter clockwise rotation	-	(x)	(x)	(x)	(x)	(x)

Frame size		5	6	10	12	14	19
Code	Function						
M	Motor	x	x	x	-	-	x
Q	Motor, low noise	x	-	x	x	x	x
S	Motor, high speed	-	-	(x)	(x)	(x)	(x)
H	Motor, high pressure	(x)	-	(x)	-	-	(x)
R	Pump, clockwise rot'n	(x)	-	(x)	(x)	(x)	(x)
L	Pump, counter clockw.	(x)	-	(x)	(x)	(x)	(x)

For other versions, contact Parker Hannifin

Frame size		5	6	10	12	14	19
Code	Main ports						
B	BSP threads	x	x	x	x	x	x
U	SAE, UN threads	(x)	(x)	(x)	(x)	(x)	(x)

Frame size		5	6	10	12	14	19
Code	Shaft*						
K	Metric key	x	x	x	x	x	x
J	Metric key	(x)	(x)	(x)	(x)	-	-
P	Metric key	-	-	-	-	(x)	-
A	Spline, DIN 5480	-	(x)	(x)	(x)	-	-
D	Spline, DIN 5480	x	x	x	x	x	x
S	Spline, SAE	(x)	-	-	-	-	-
V	Tapered shaft	-	(x)	(x)	(x)	(x)	-

*See also dimensional drawings on pages 15-23.

Frame size		5	6	10	12	14	19
Code	Mounting flange						
C	CETOP flange	x	x	x	x	x	x

Frame size		5	6	10	12	14	19
Code	Shaft seal						
V	FPM, high pressure, high temperature	x	x	x	x	x	x

For other versions, contact Parker Hannifin

x: Available (x): Optional -: Not available

Frame size		5	6	10	12	14	19
Code	Option						
00	Standard	x	x	x	x	x	x
P_	Prepared for speed sensor	-	(x)	(x)	(x)	(x)	(x)
B_	Power Boost and Prepared for speed sensor	-	(x)	(x)	(x)	(x)	(x)
_T	Painted Black	(x)	(x)	(x)	(x)	(x)	(x)

NOTE: All combinations are not valid, please contact Parker Hannifin

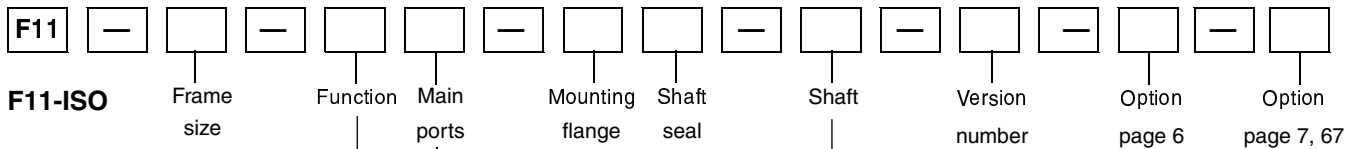

Frame size	
Code	Displacem. (cm ³ /rev)
006	6.0
010	9.8
012	12.5
014	14.3

Version number	
(assigned for special versions)	

Frame size		6	10	12	14
Code	Function				
M	Motor	x	x	-	-
Q	Motor, low noise	-	x	x	x
S	Motor, high speed	-	(x)	(x)	(x)
H	Motor, high pressure	-	(x)	-	-
R	Pump, clockwise rot'n	-	(x)	(x)	(x)
L	Pump, counter clockw.	-	(x)	(x)	(x)

Frame size		6	10	12	14
Code	Option				
0000	Standard	x	x	x	x
MUVR	Make up/Anti cavitation valve clockwise rotation	(x)	(x)	(x)	(x)
MUVL	Make up/Anti cavitation valve counter clockwise rotation	(x)	(x)	(x)	(x)

For other versions, contact Parker Hannifin

Frame size		6	10	12	14
Code	Main ports				
F	Metric threads	-	x	x	x
B	BSP threads	x	(x)	(x)	(x)
M	Side ports, metric	-	(x)	(x)	(x)

Frame size		6	10	12	14
Code	Shaft*				
K	Metric key	x	x	x	x
J	Metric key	(x)	(x)	(x)	-
P	Metric key	-	-	-	(x)
A	Spline, DIN 5480	(x)	(x)	(x)	-
D	Spline, DIN 5480	x	x	x	x
V	Tapered shaft	(x)	(x)	(x)	(x)

*See also dimensional drawings on pages 25-29.

Frame size		6	10	12	14
Code	Mounting flange				
I	ISO flange	x	x	x	x

x: Available (x): Optional -: Not available

Frame size		6	10	12	14
Code	Shaft seal				
V	FPM, high pressure, high temperature	x	x	x	x

For other versions, contact Parker Hannifin

Frame size		6	10	12	14
Code	Option				
00	Standard	x	x	x	x
P_	Prepared for speed sensor	(x)	(x)	(x)	(x)
B_	Power Boost and Prepared for speed sensor	(x)	(x)	(x)	(x)
_T	Painted Black	(x)	(x)	(x)	(x)

NOTE: All combinations are not valid, please contact Parker Hannifin



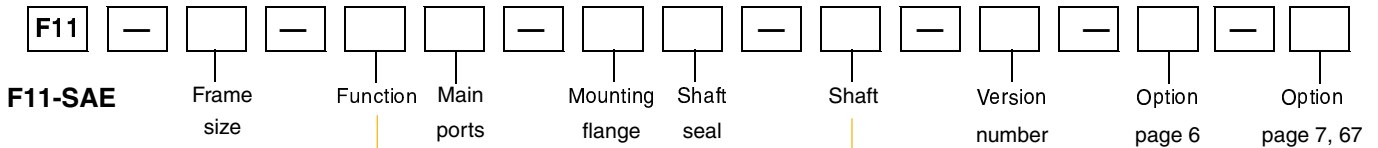

Frame size	
Code	Displacem. (cm ³ /rev)
006	6.0
010	9.8
012	12.5
014	14.3
019	19.0

Version number
 (assigned for special versions)

Frame size		6	10	12	14	19
Code	Option					
0000	Standard	x	x	x	x	x
MUVR	Make up/Anti cavitation valve clockwise rotation	(x)	(x)	(x)	(x)	(x)
MUVL	Make up/Anti cavitation valve counter clockwise rotation	(x)	(x)	(x)	(x)	(x)

Frame size		6	10	12	14	19
Code	Function					
M	Motor	x	x	-	-	x
Q	Motor, low noise	-	x	x	x	x
S	Motor, high speed	-	(x)	(x)	(x)	(x)
H	Motor, high pressure	-	(x)	-	-	(x)
R	Pump, clockwise rot'n	-	(x)	(x)	(x)	(x)
L	Pump, counter clockw.	-	(x)	(x)	(x)	(x)

Frame size		6	10	12	14	19
Code	Shaft*					
T	SAE key	-	-	-	x	x
S	SAE spline	x	x	x	x	x
K	Metric key	x	x	x	-	-
J	Metric key	(x)	(x)	(x)	-	-
V	Tapered shaft	(x)	(x)	(x)	(x)	-

*See also dimensional drawings on pages 31-37.

For other versions, contact Parker Hannifin

Frame size		6	10	12	14	19
Code	Main ports					
U	SAE, UN threads	x	x	x	x	x
B	BSP threads	(x)	(x)	(x)	(x)	(x)

Frame size		6	10	12	14	19
Code	Shaft seal					
V	FPM, high pressure, high temperature	x	x	x	x	x

For other versions, contact Parker Hannifin

x: Available (x): Optional -: Not available

Frame size		6	10	12	14	19
Code	Option					
00	Standard	x	x	x	x	x
P_	Prepared for speed sensor	(x)	(x)	(x)	(x)	(x)
B_	Power Boost and Prepared for speed sensor	(x)	(x)	(x)	(x)	(x)
_T	Painted Black	(x)	(x)	(x)	(x)	(x)

NOTE: All combinations are not valid, please contact Parker Hannifin

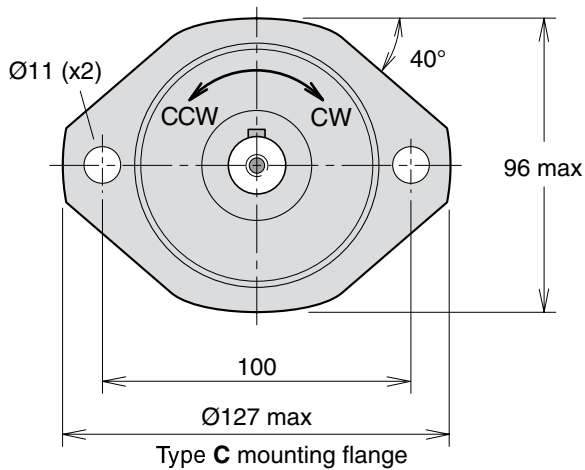

Main port A
3/4"-16 UNF
O-ring boss;
SAE J514d

Main port B
3/4"-16 UNF
O-ring boss;
SAE J514d

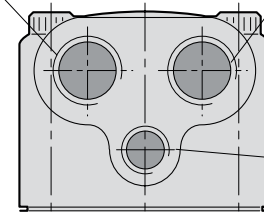

Drain port C
9/16"-18 UNF
O-ring boss;
SAE J514d

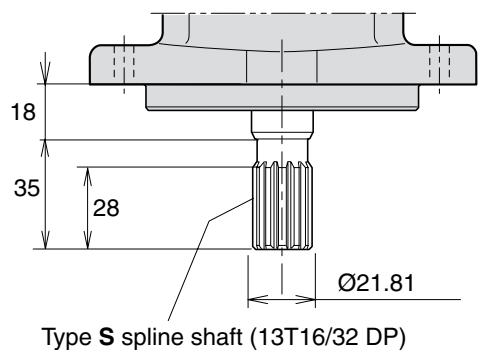
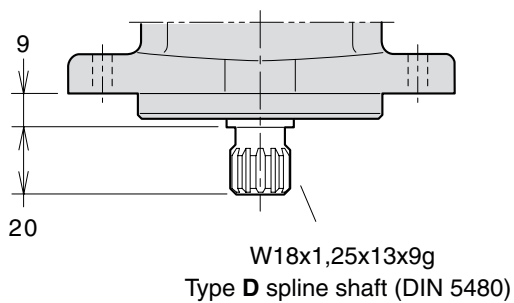
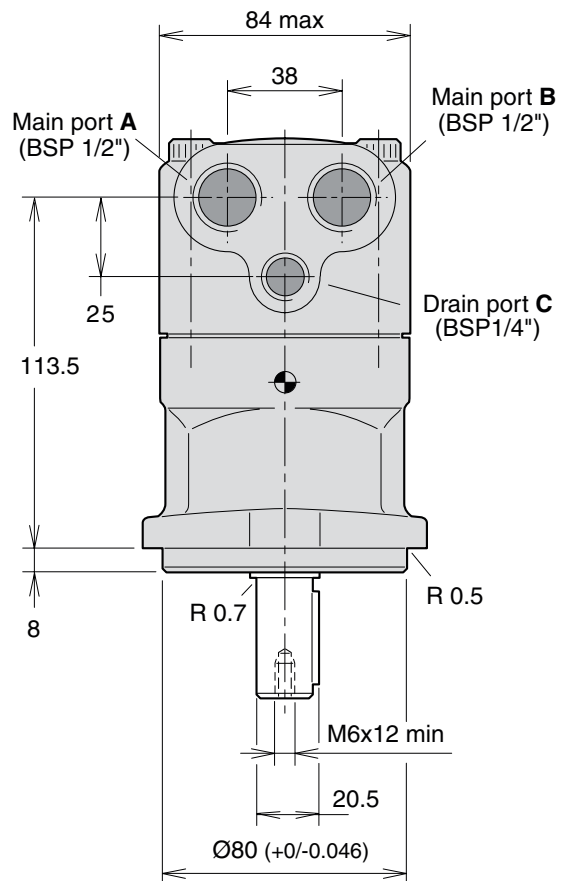
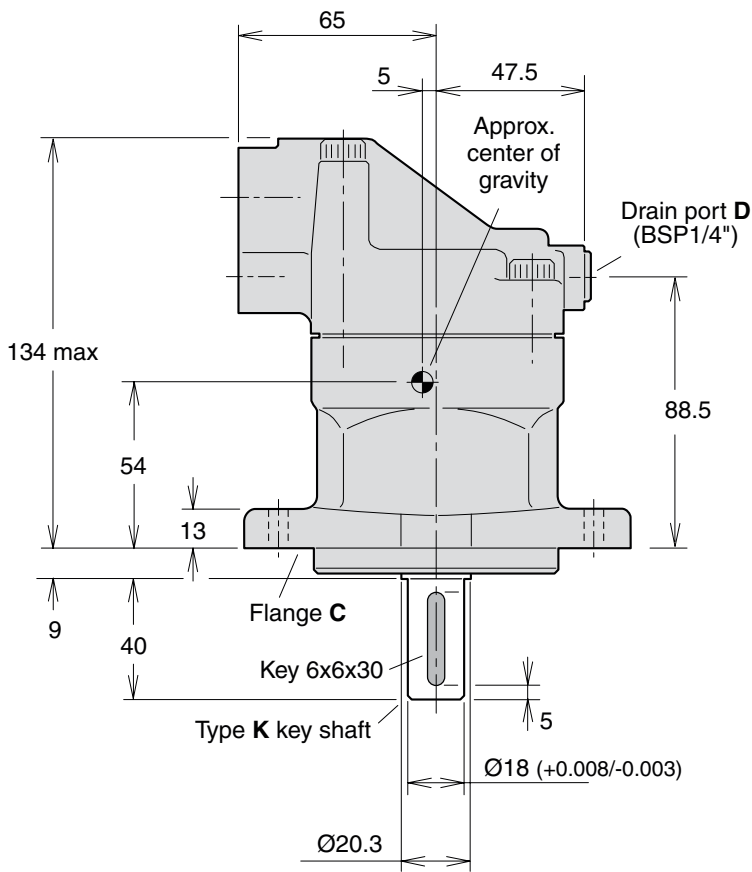

F11-006, -010
 (CETOP versions)

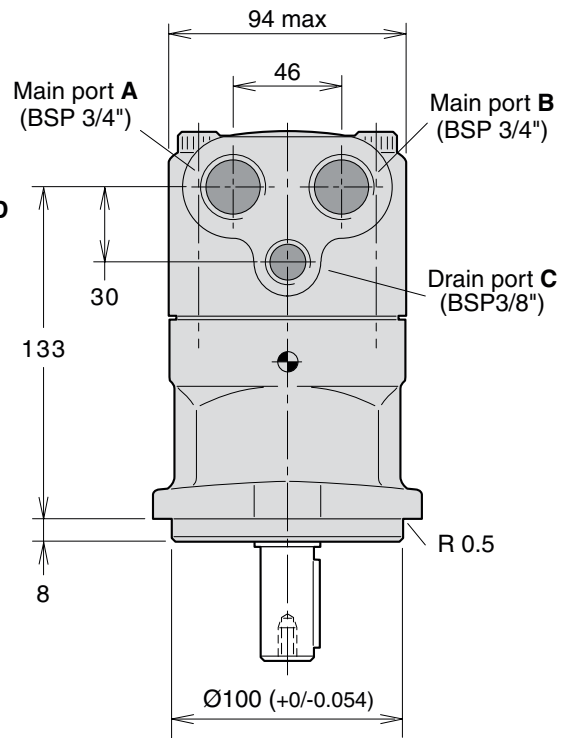
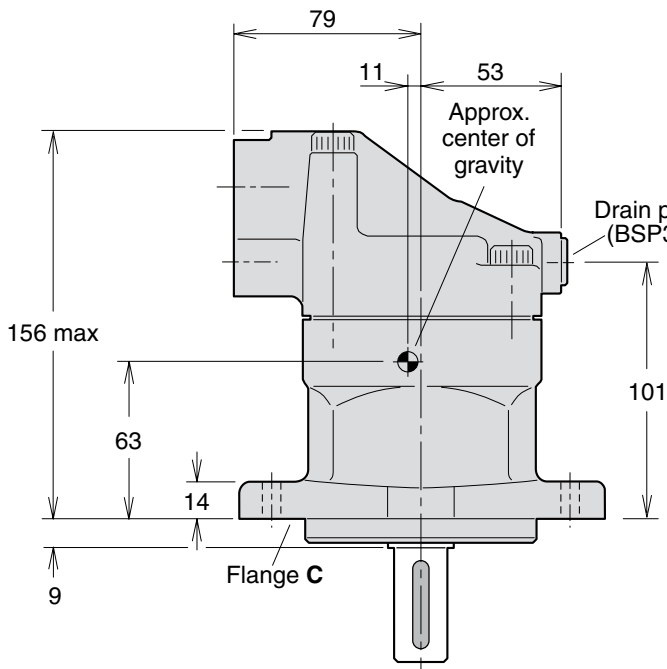
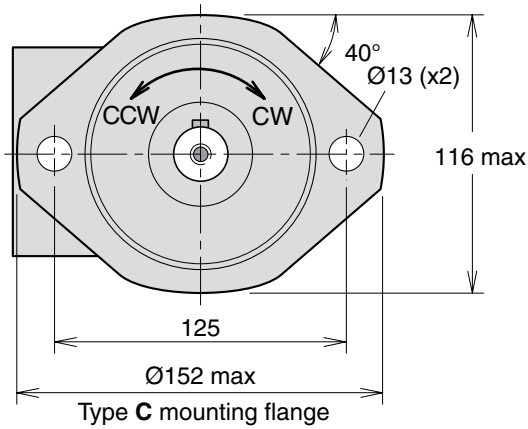

F11-006, -010
 (CETOP versions)

Make up/Anti cavitation valve
 (MUVL or MUVR optional;
 clockwise rotation shown).

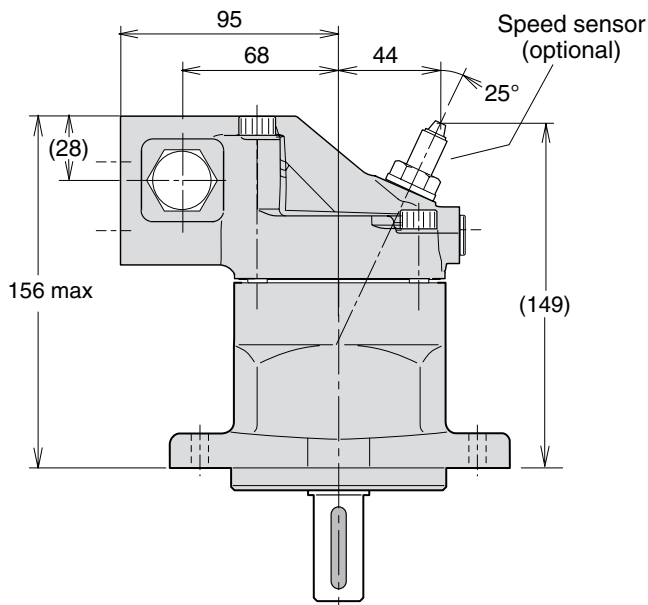
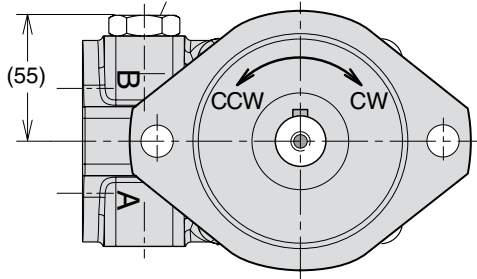

Shaft options

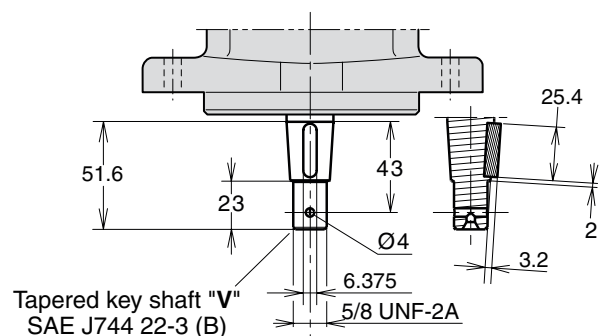
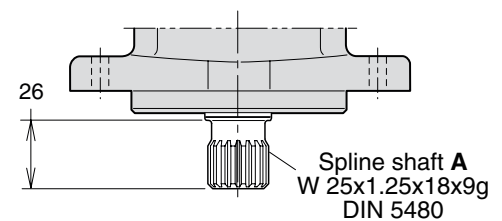
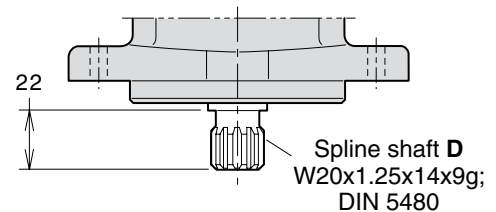
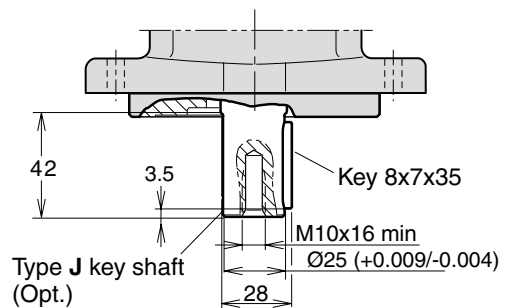
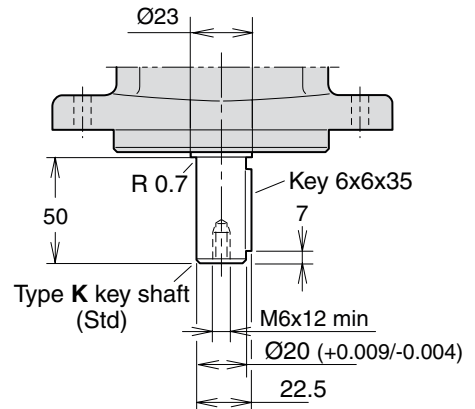

F11-012
 (CETOP versions)

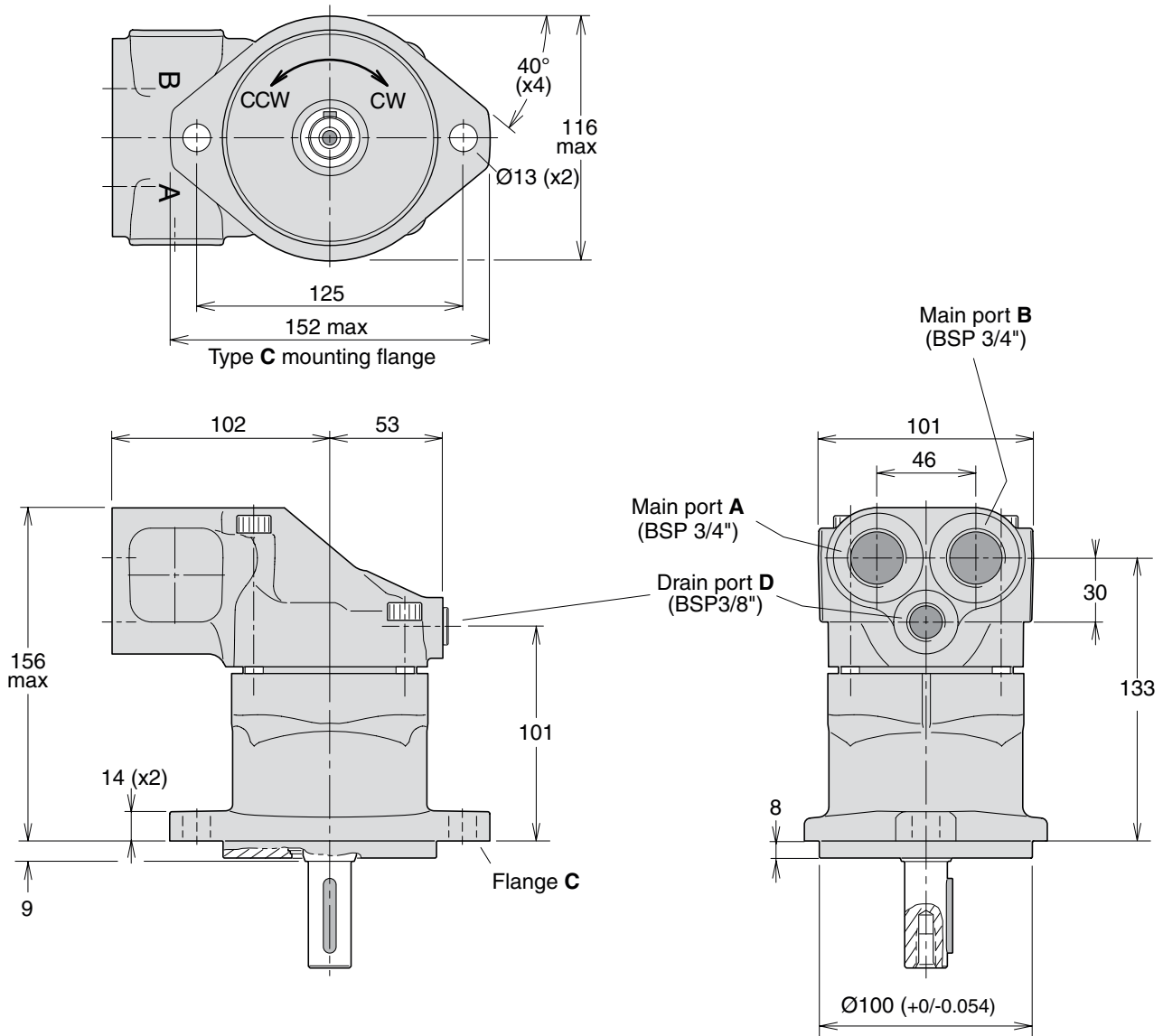

F11-012
 (CETOP versions)

Make up/Anti cavitation valve
 (MUVL or MUVR optional;
 clockwise rotation shown)

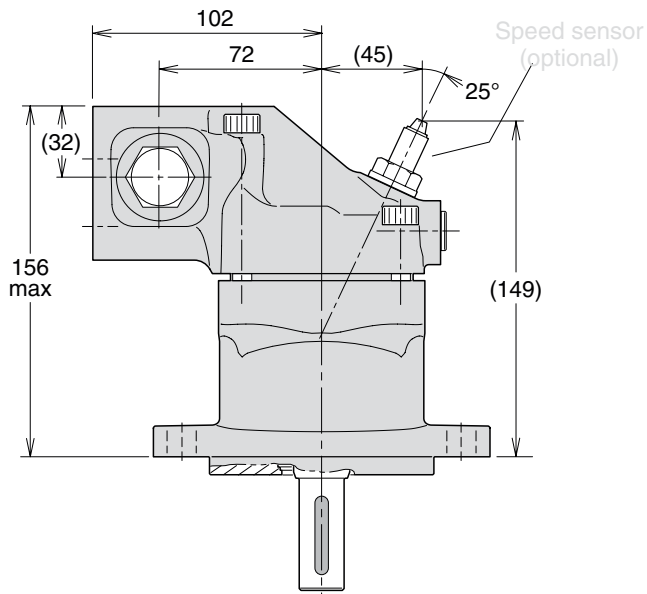
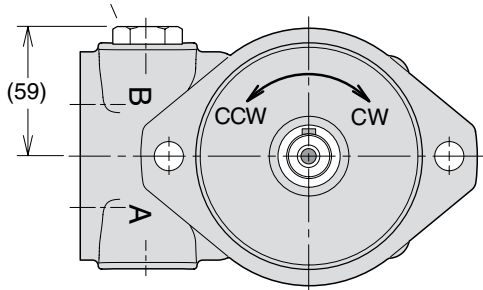

Shaft options

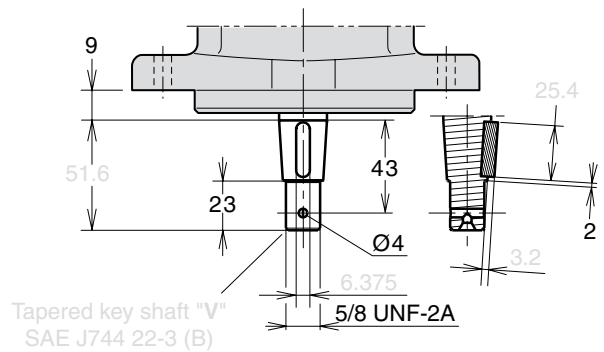
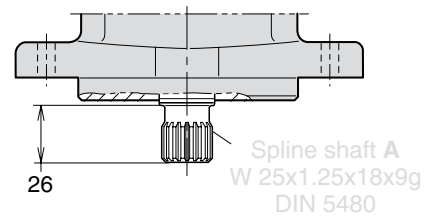
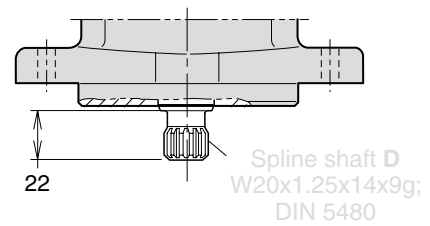
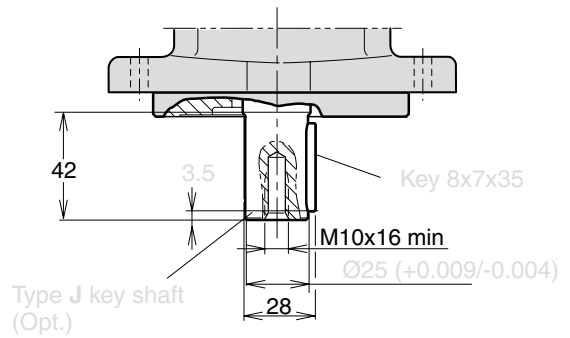
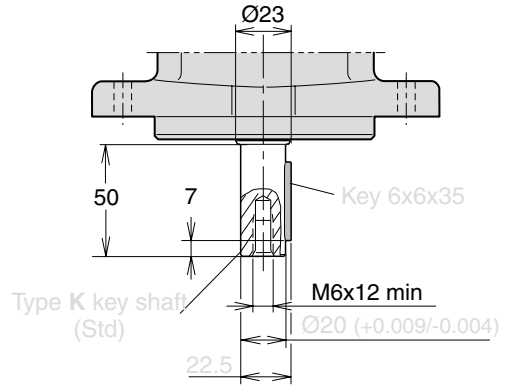

2

F11-014
 (CETOP versions)

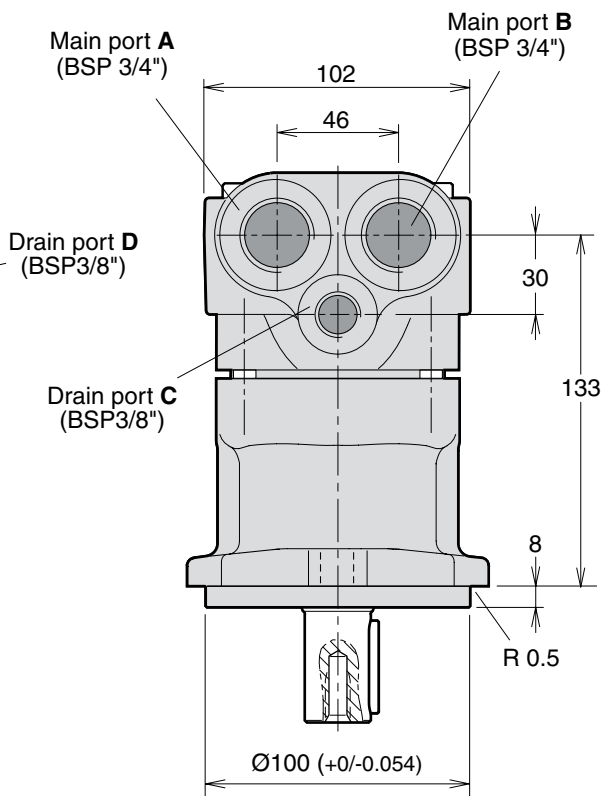
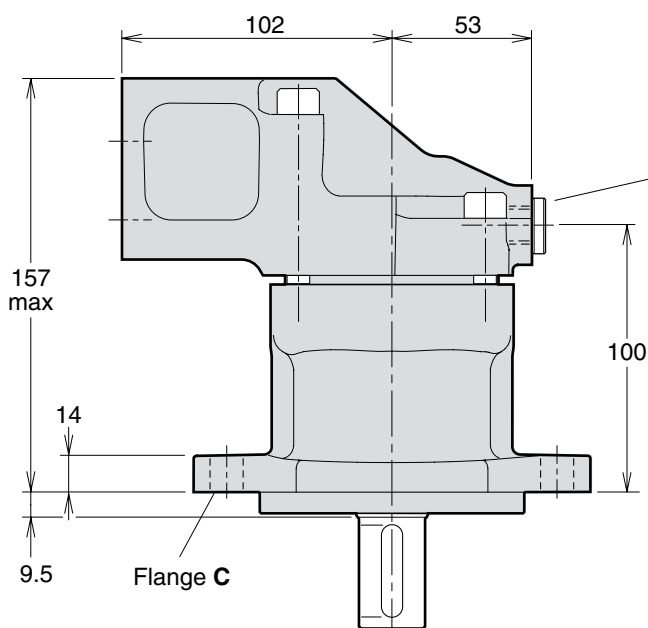
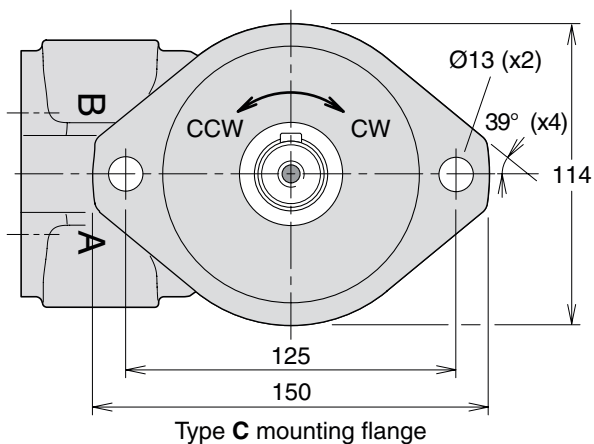

F11-014
 (CETOP versions)

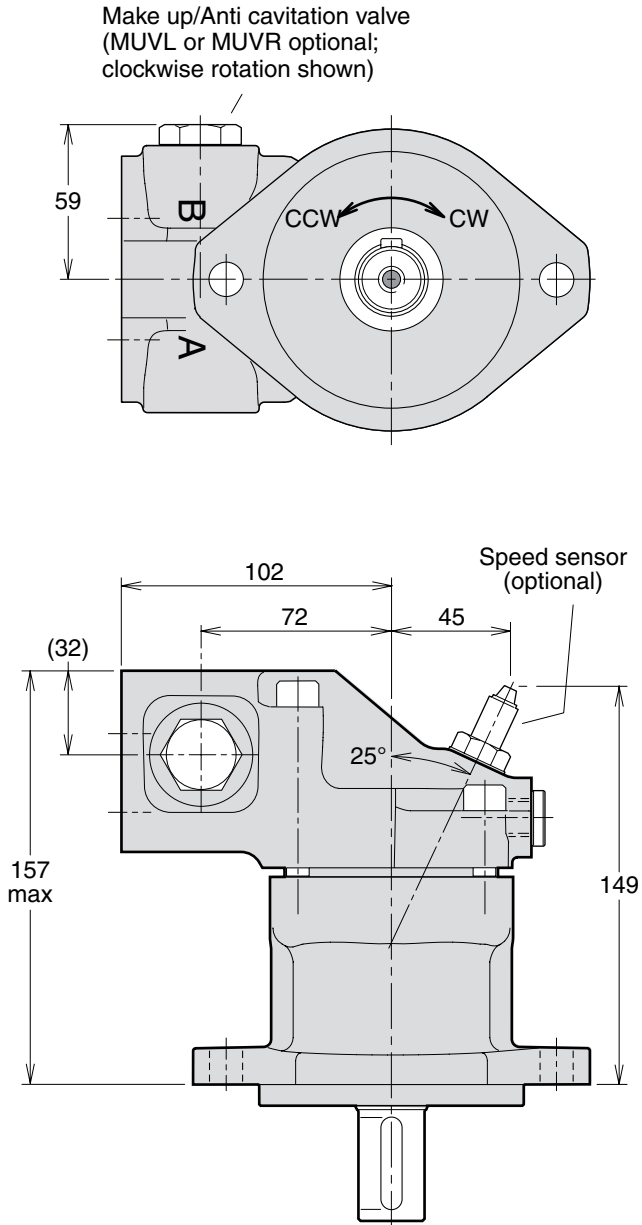

Shaft options

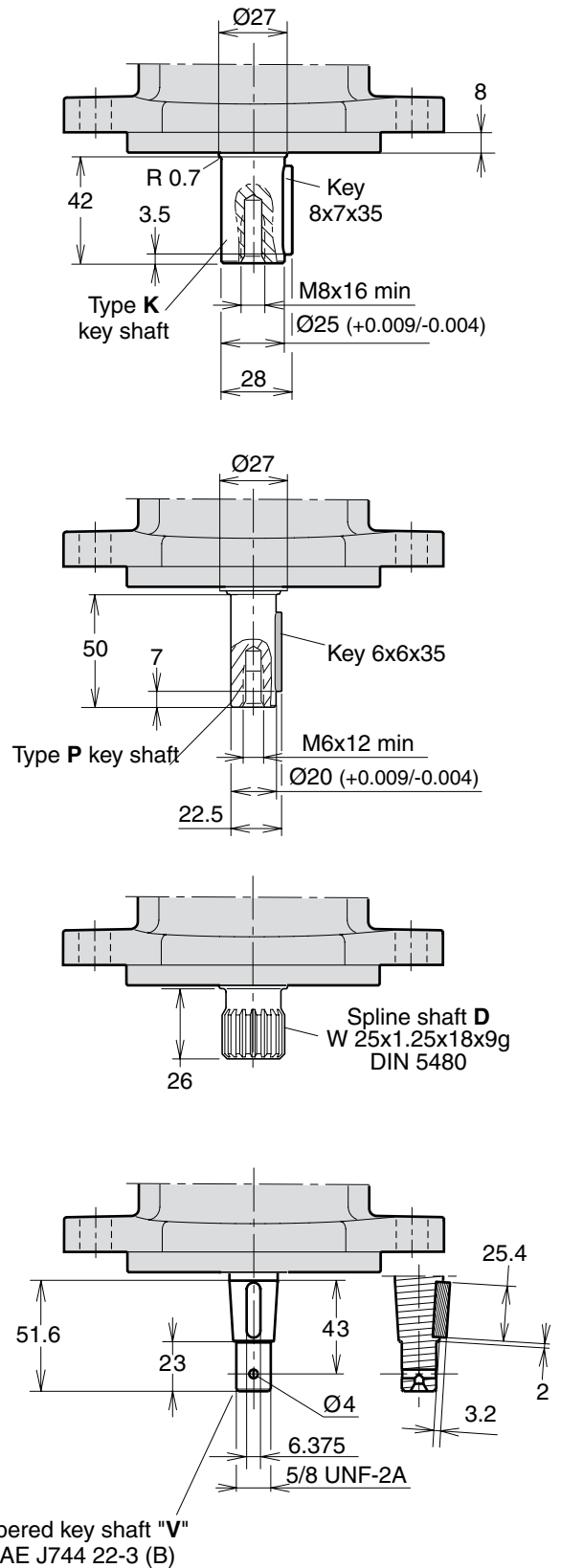

F11-019
 (CETOP version)

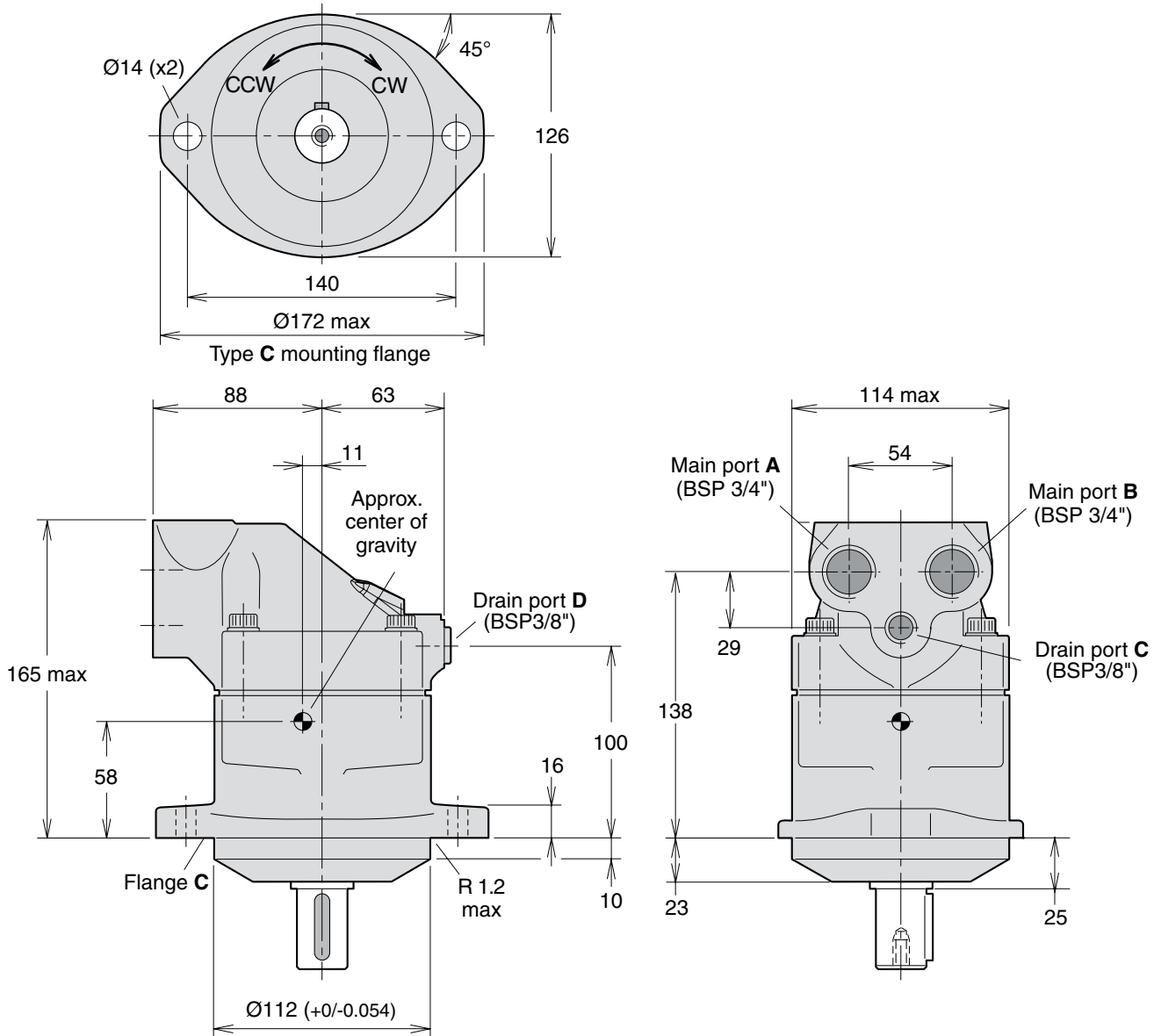

F11-019
 (CETOP version)

Make up/Anti cavitation valve
 (MUVL or MUVR optional;
 clockwise rotation shown)

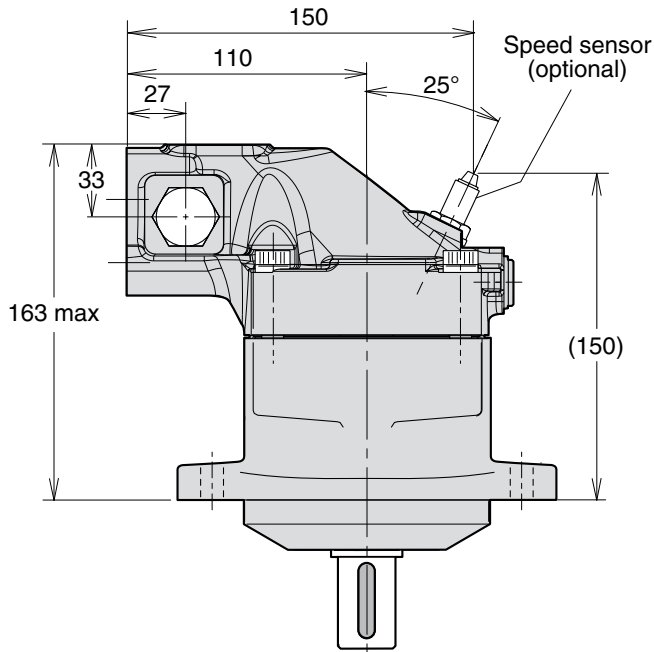
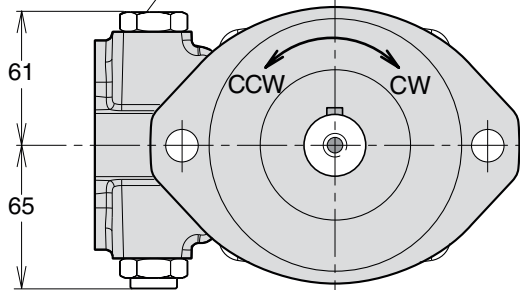

Shaft options

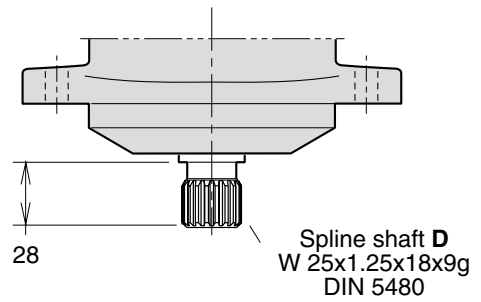
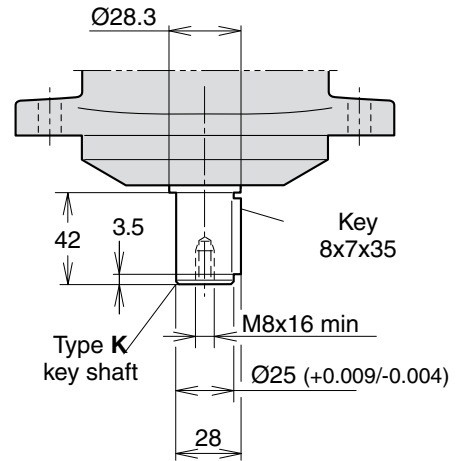

2

F11-006, -010
 (ISO versions)

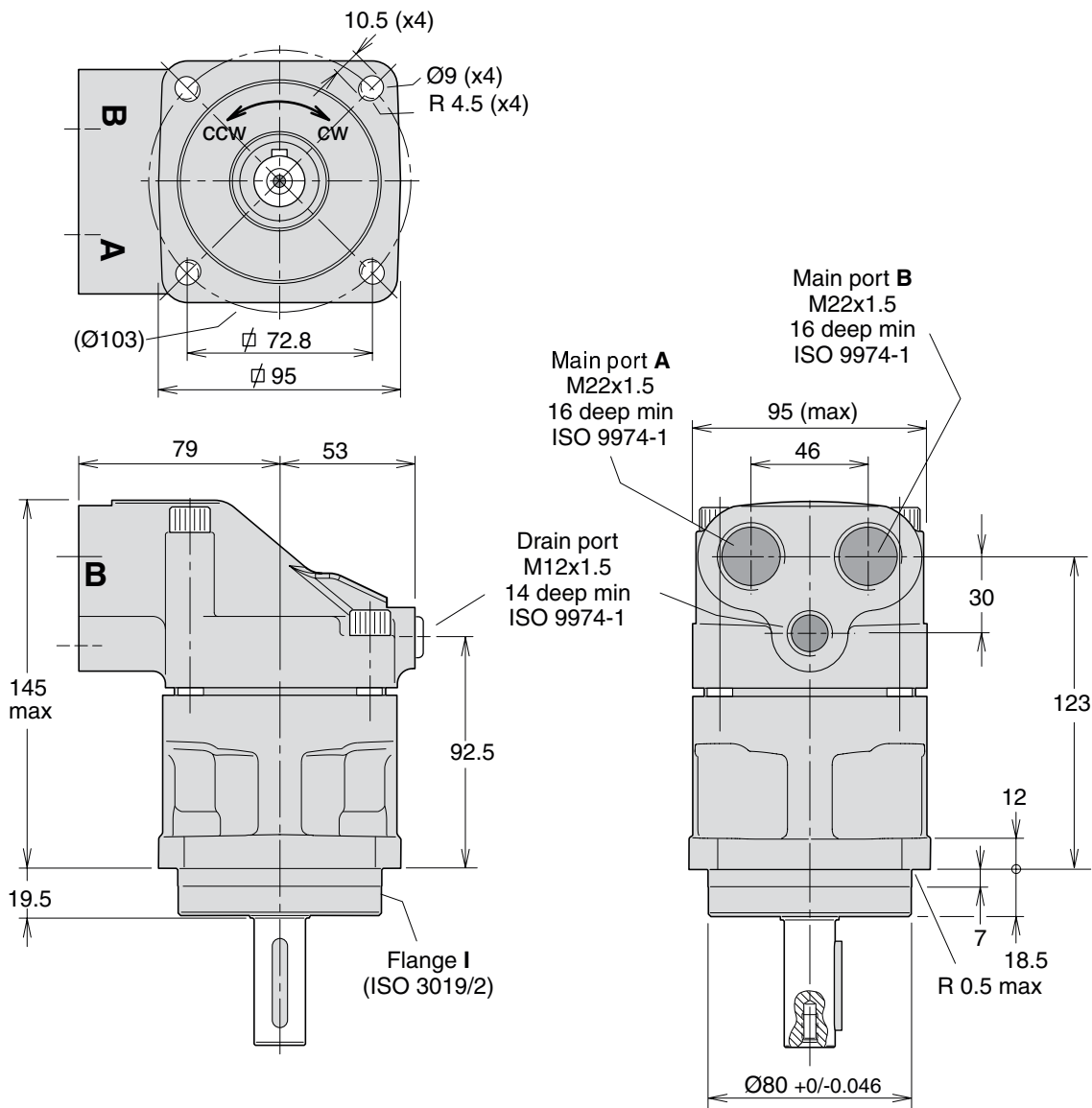

F11-006, -010
 (ISO versions)

Make up/Anti cavitation valve
 (MUVL or MUVR optional;
 clockwise rotation shown)

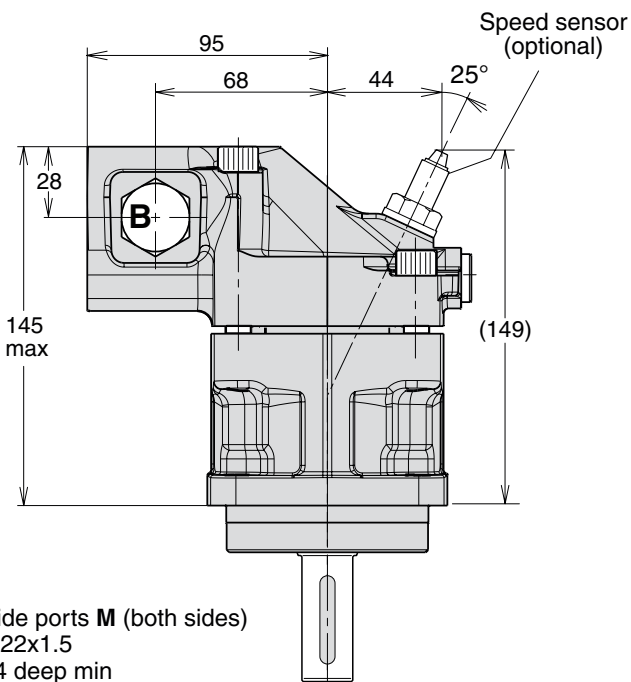
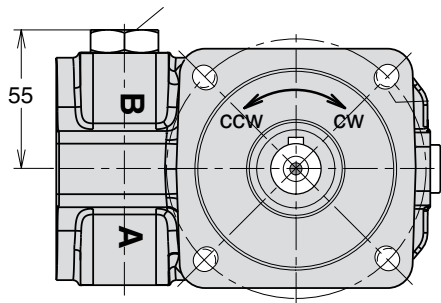

Side ports **M** (both sides)
 M22x1.5
 14 deep min
 ISO 9974-1
 Only for F11-010

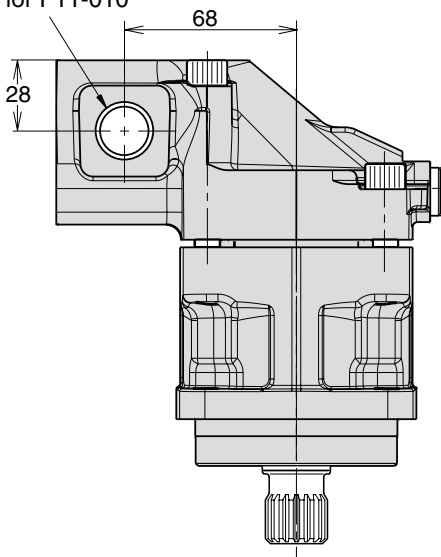

Shaft options

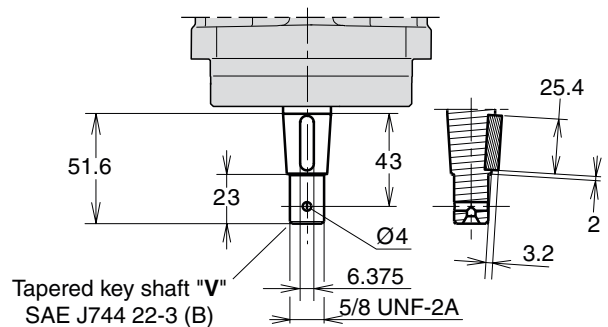
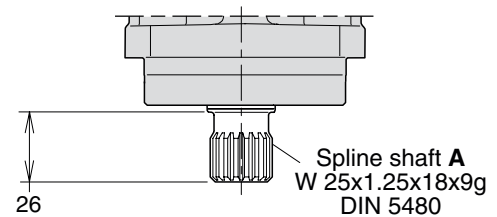
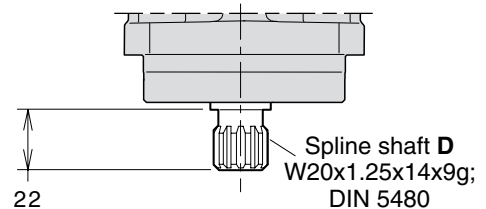
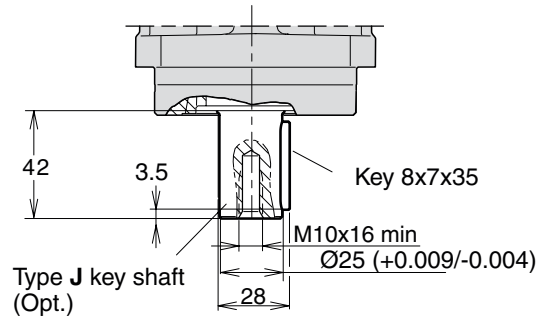
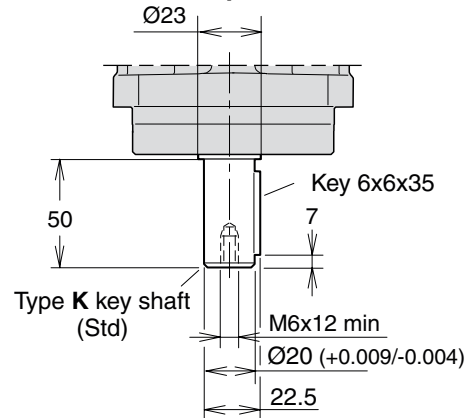

2

F11-012
 (ISO versions)

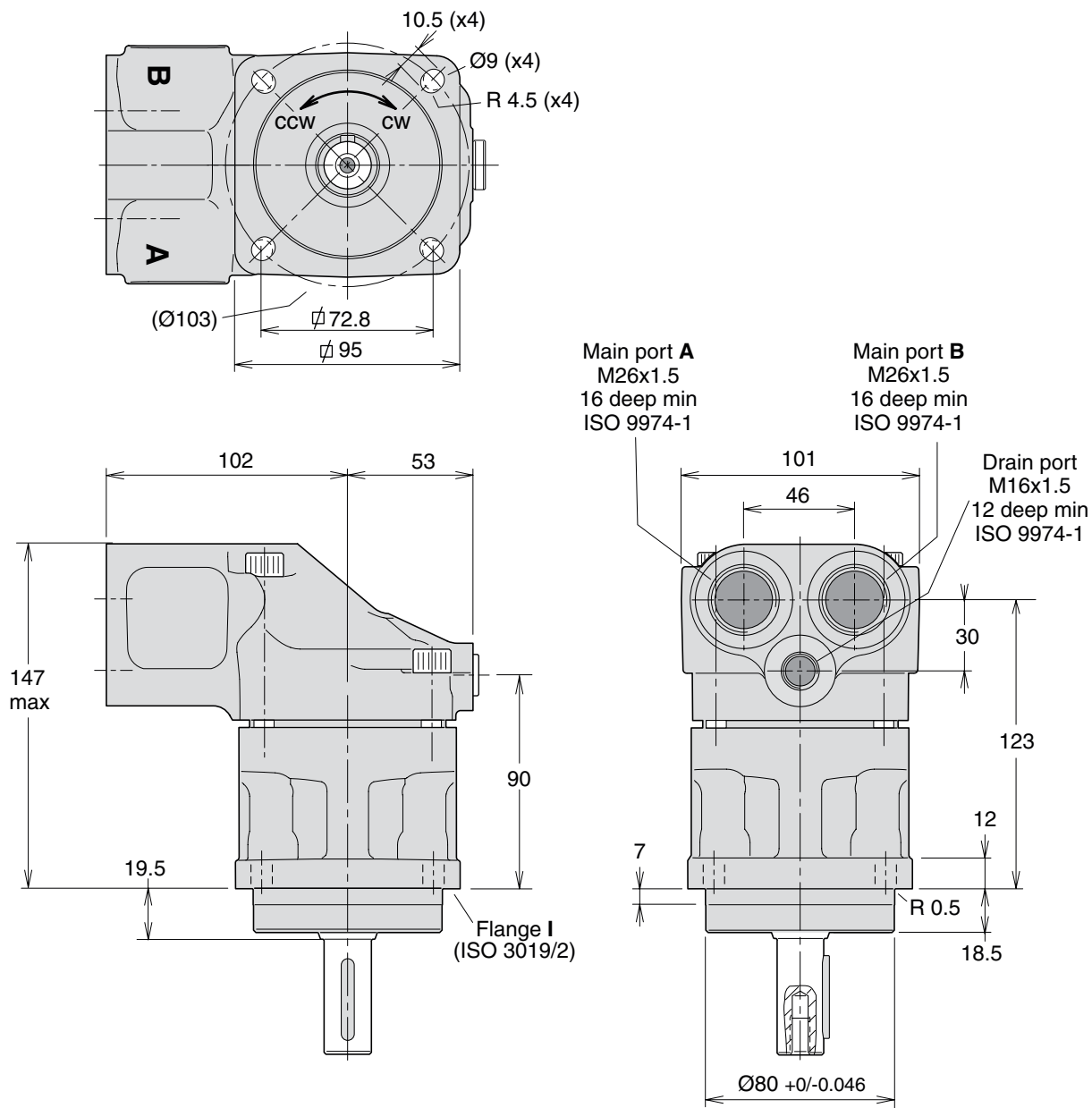

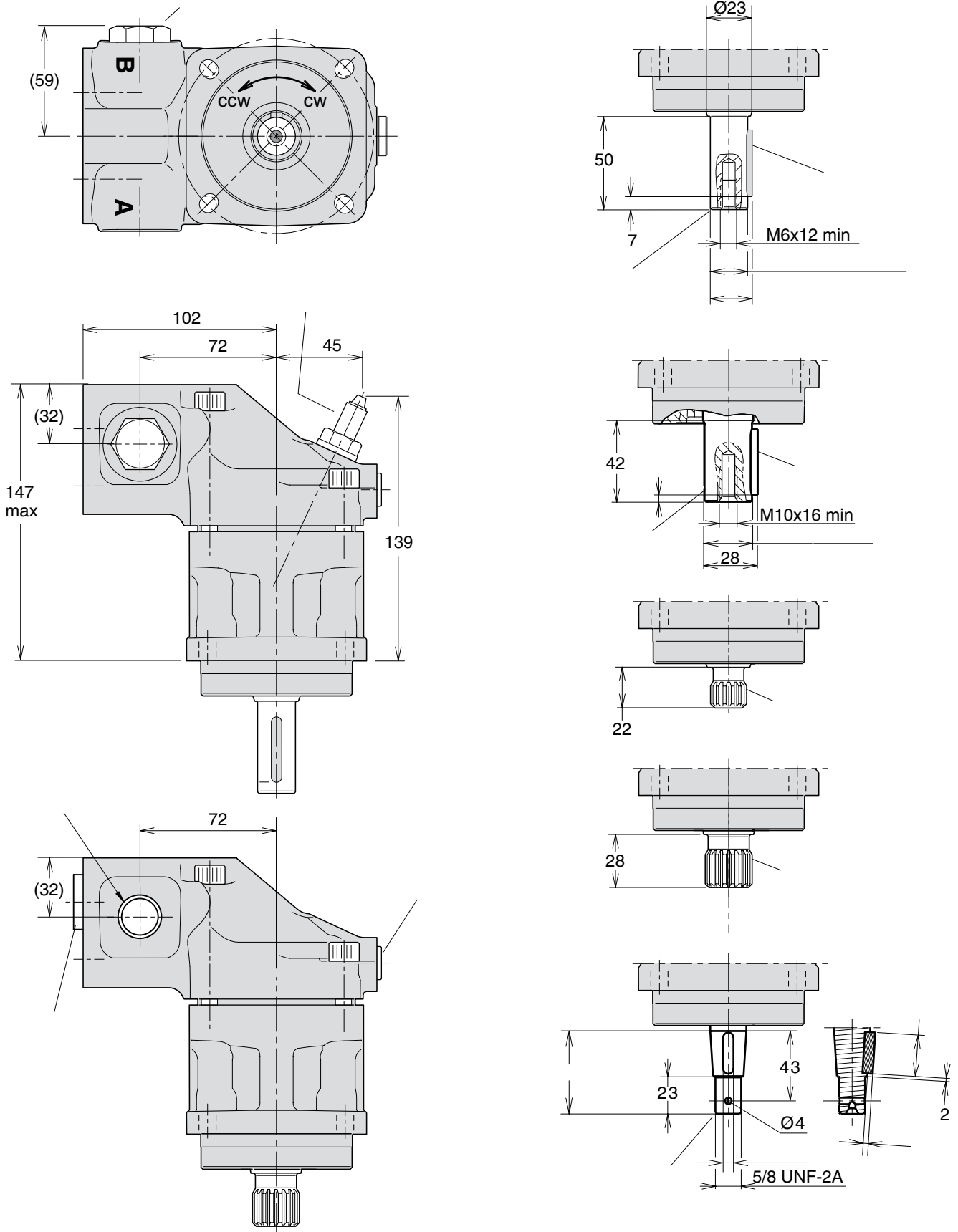

F11-014
 (ISO versions)

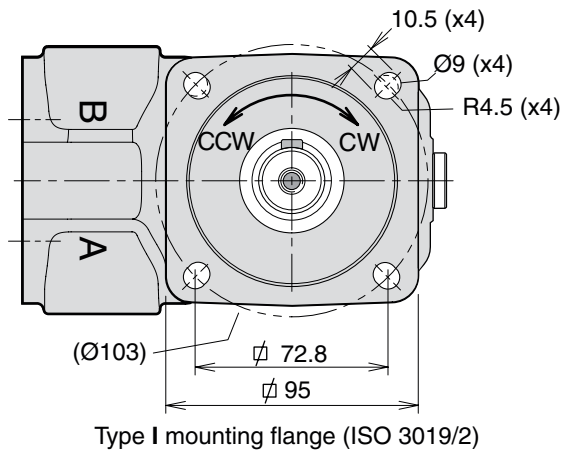

Type I mounting flange (ISO 3019/2)

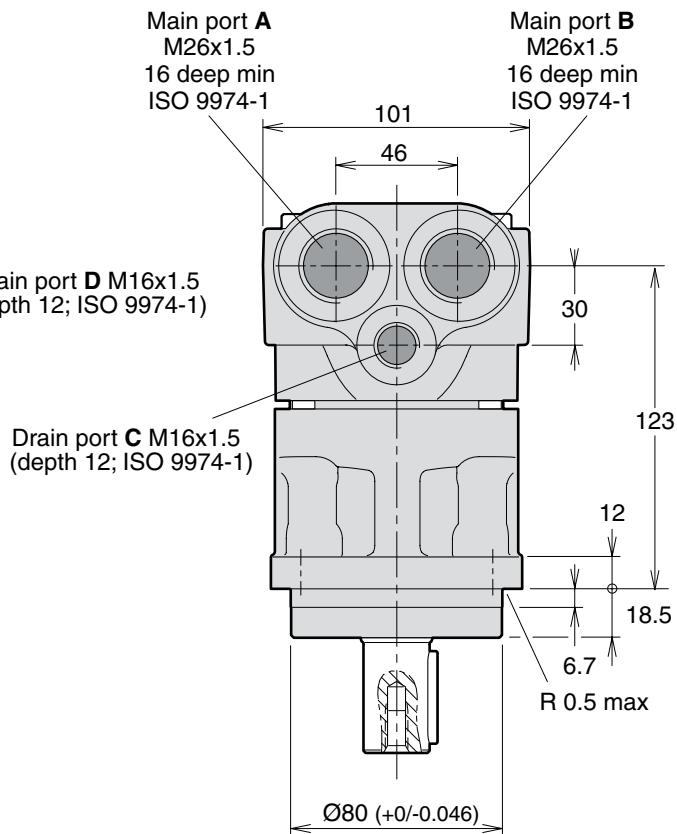
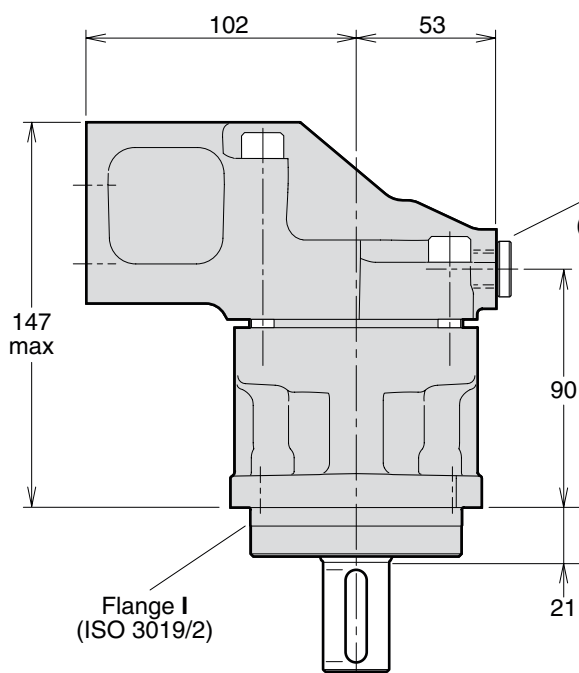

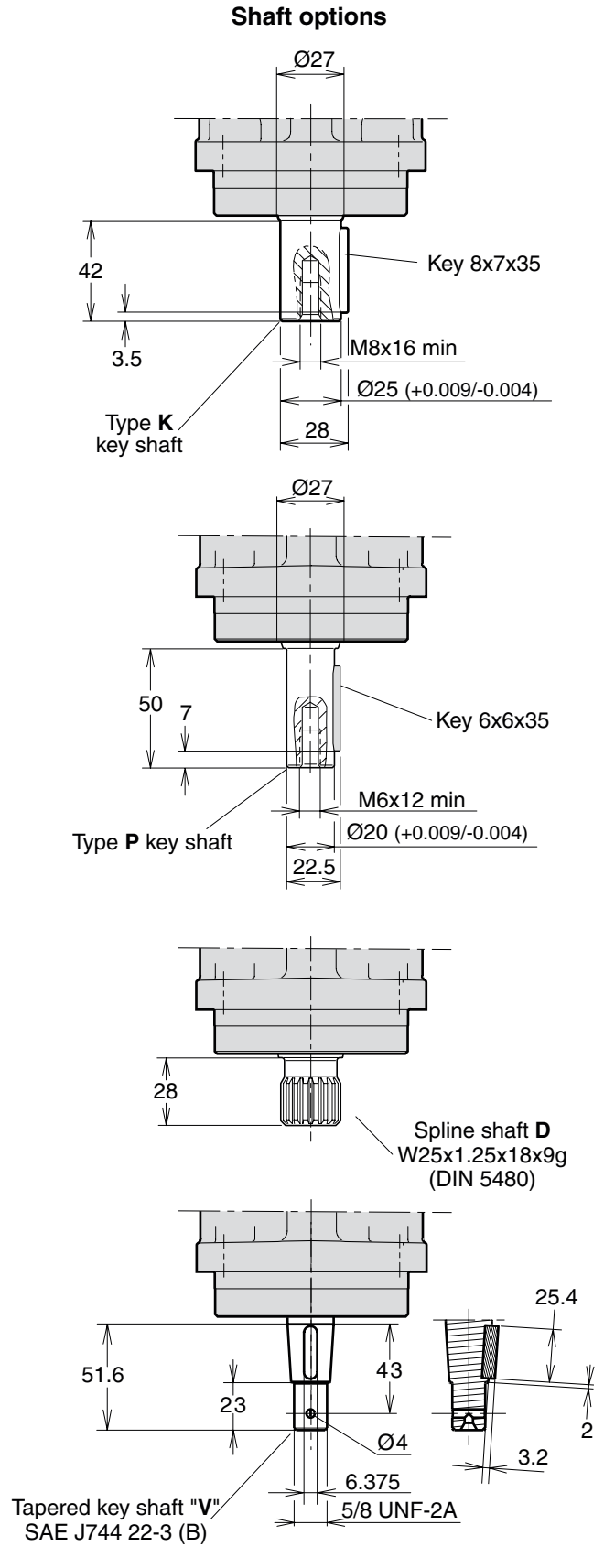
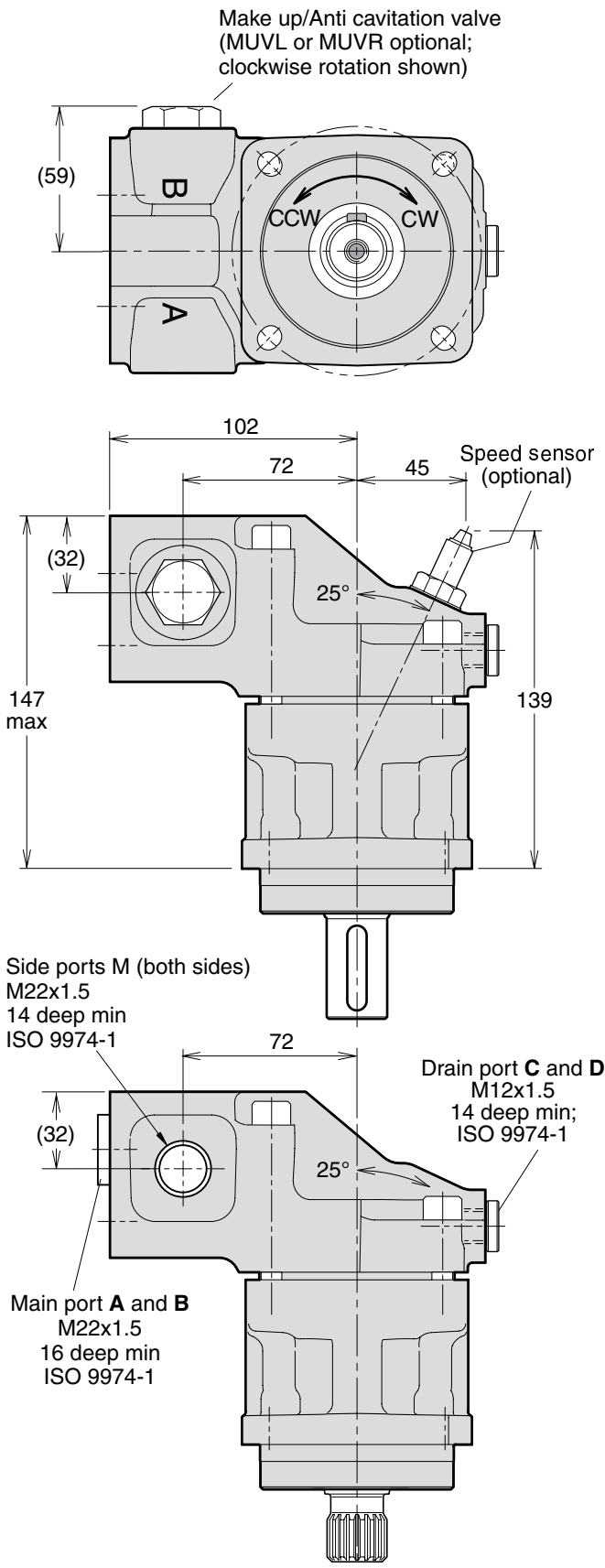

F11-006, -010
 (SAE versions)

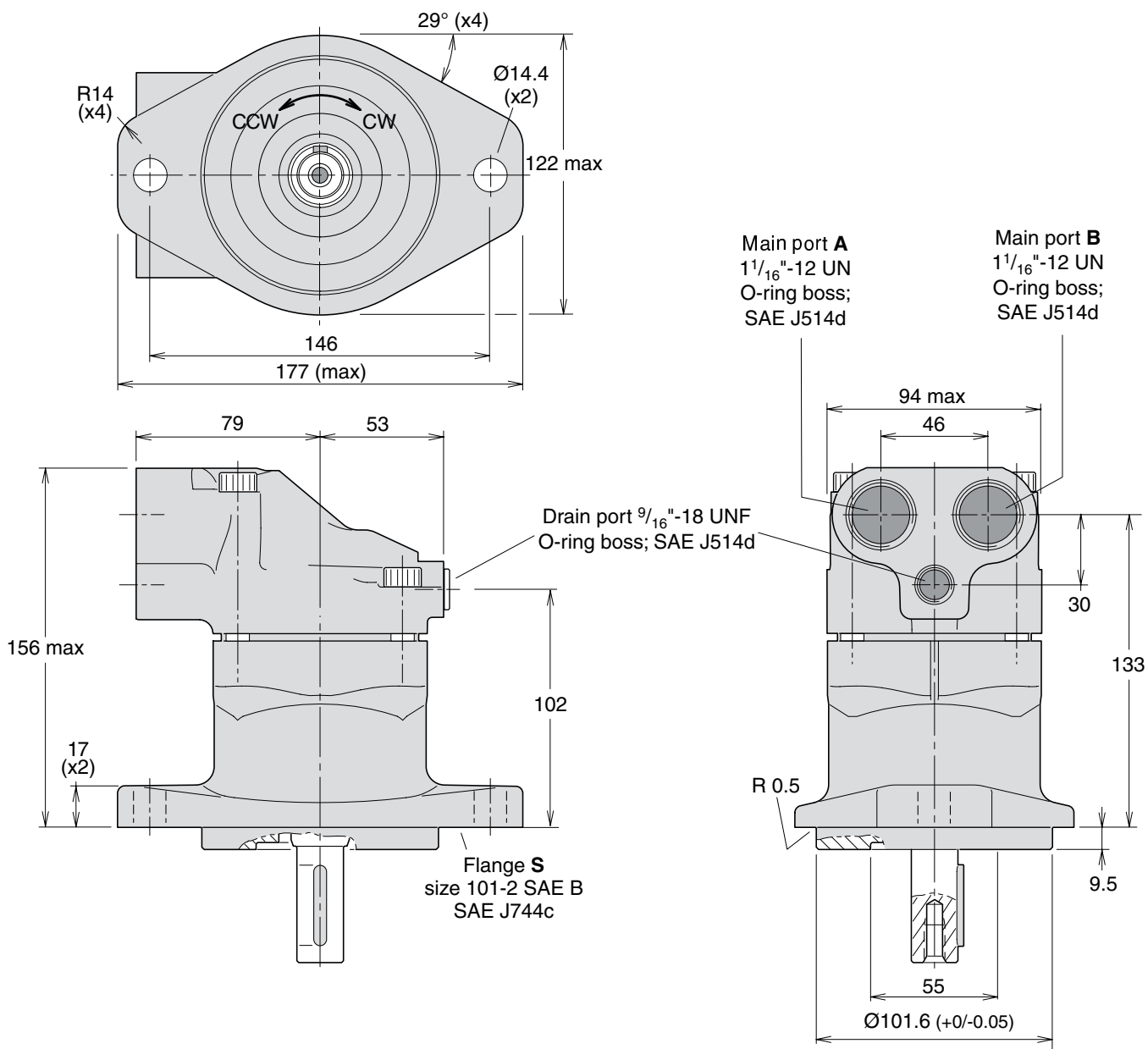

Make up/Anti cavitation valve
(MUVL or MUVR optional;
clockwise rotation shown)

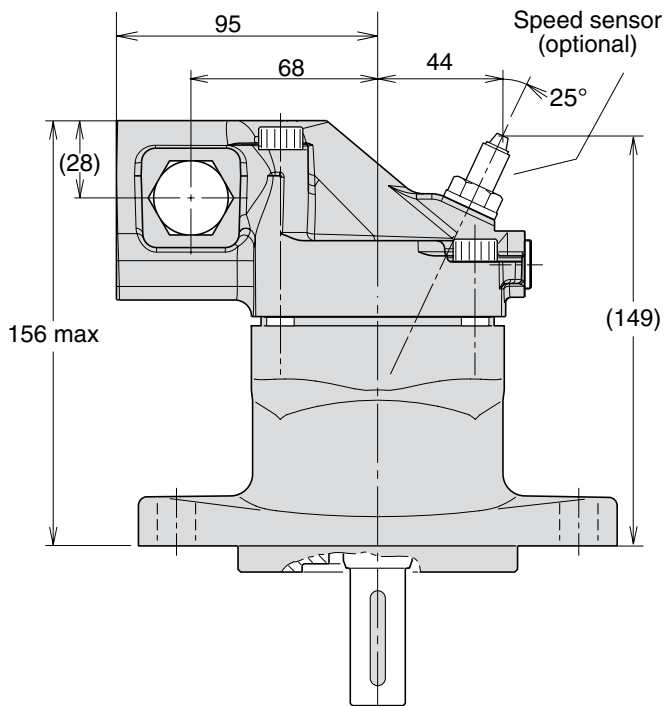
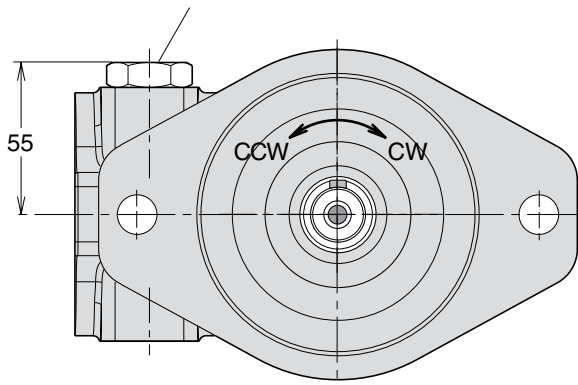

Shaft options

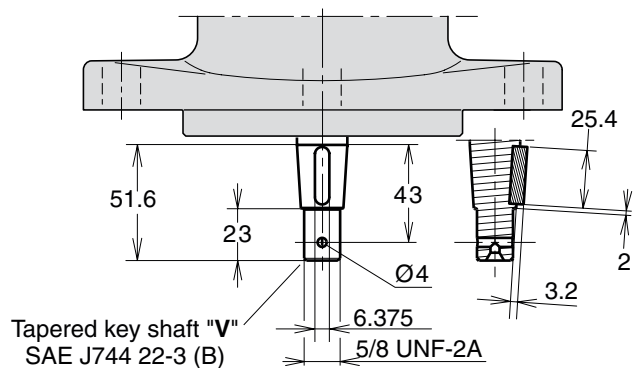
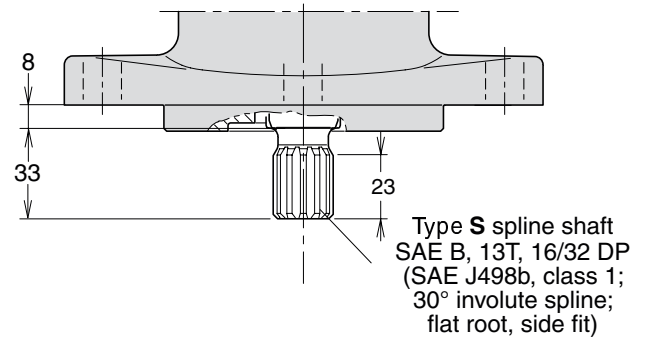
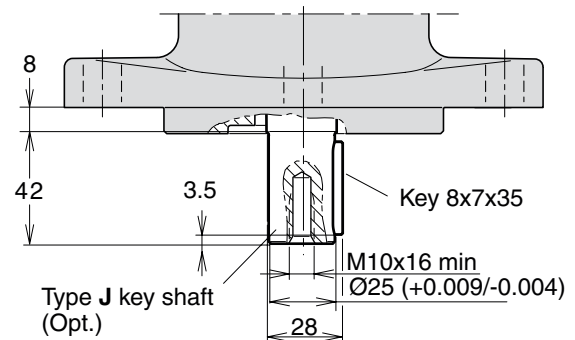
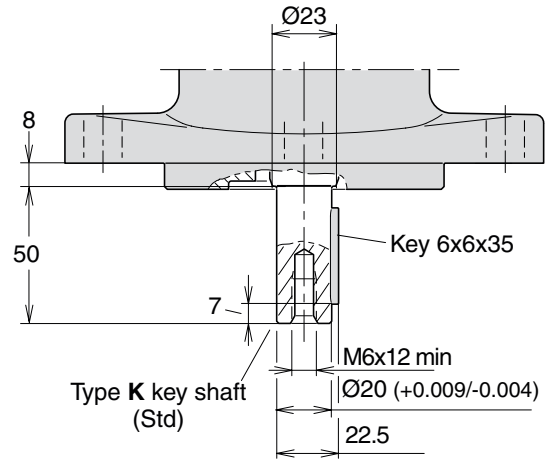

F11-012
 (SAE versions)

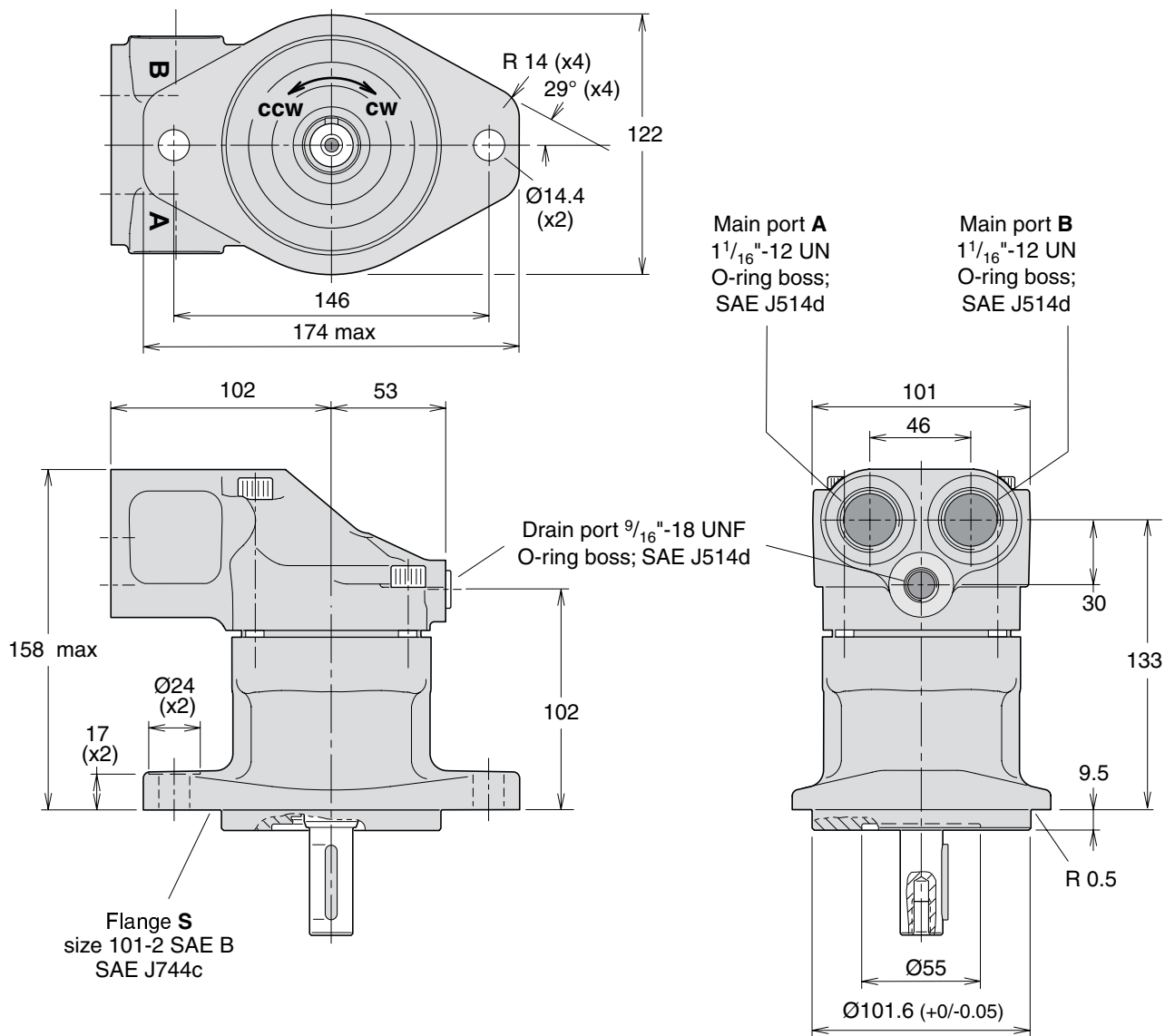

F11-012
 (SAE versions)

Make up/Anti cavitation valve
 (MUVL or MUVR optional;
 clockwise rotation shown)

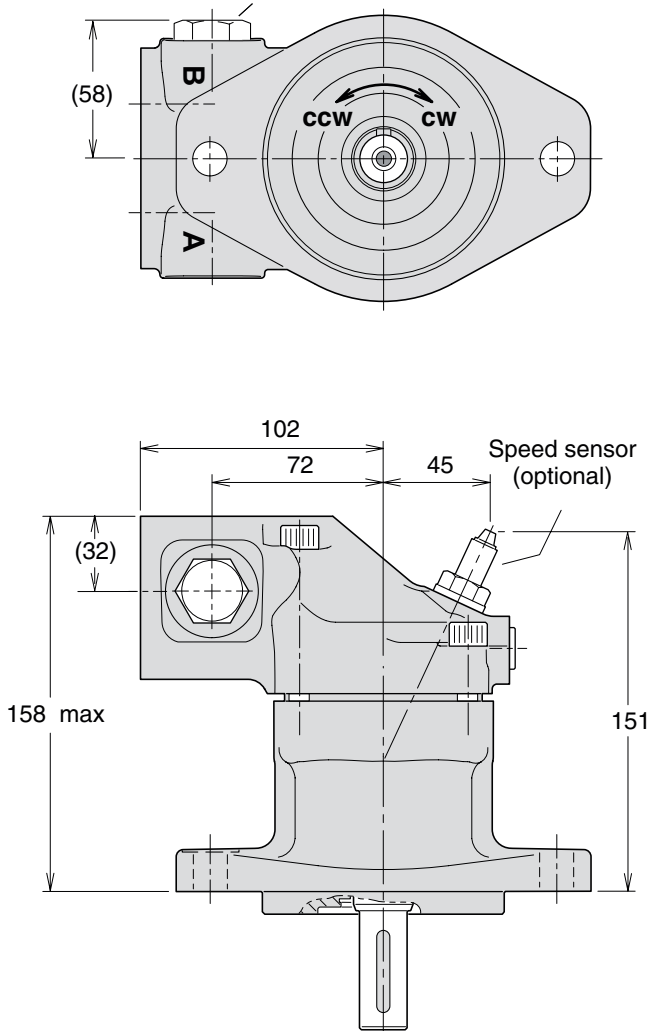

Shaft options

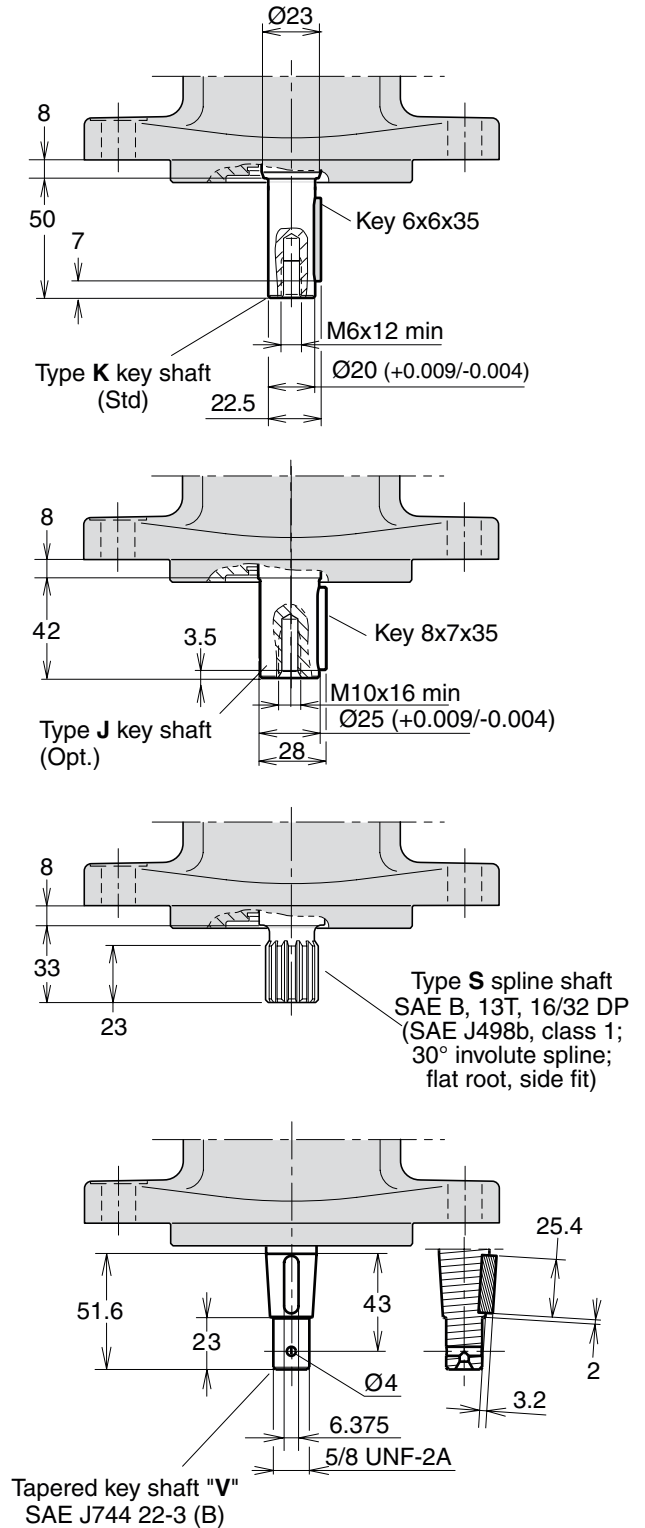

F11-014
 (SAE versions)

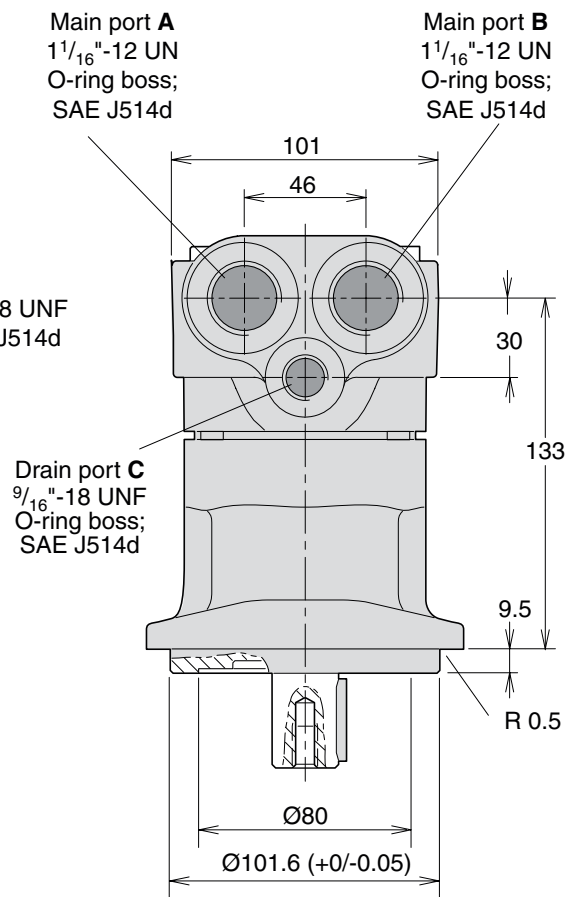
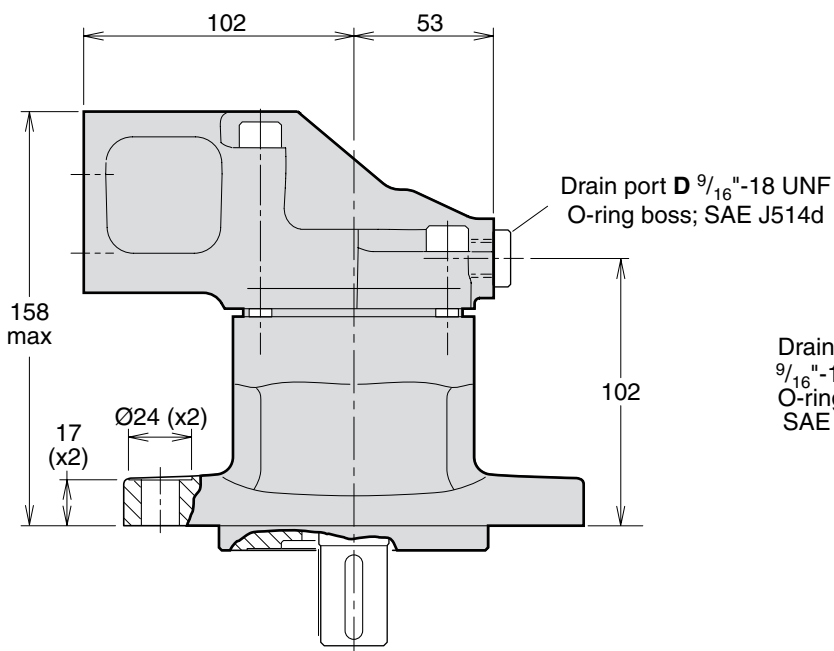
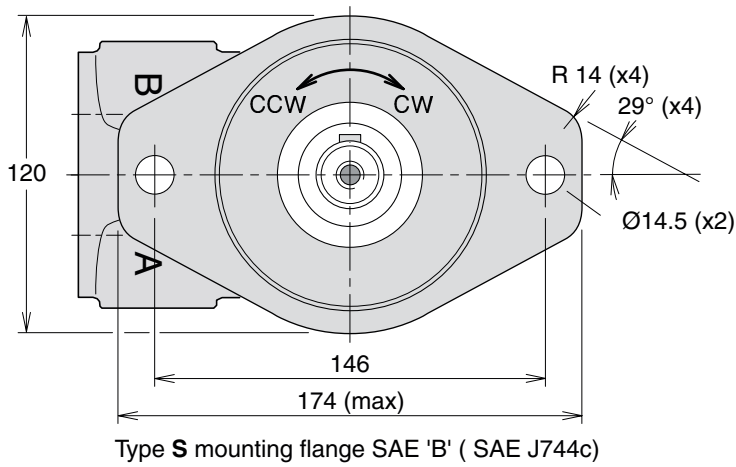

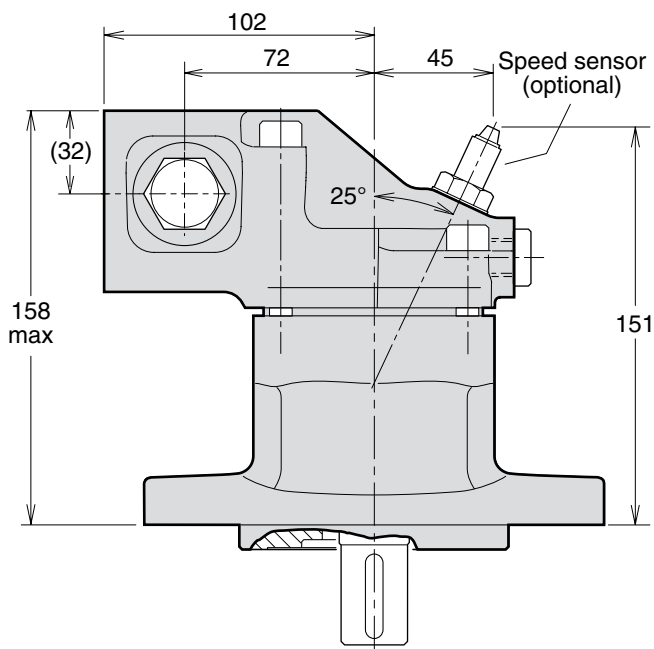
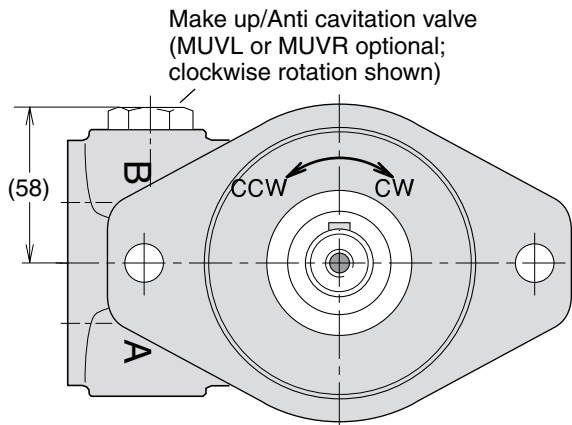

Shaft options

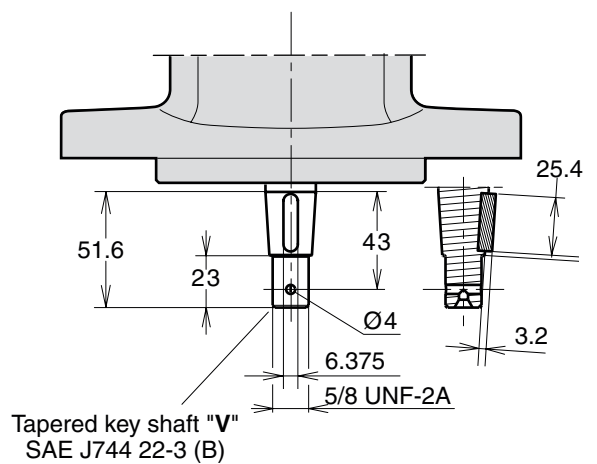
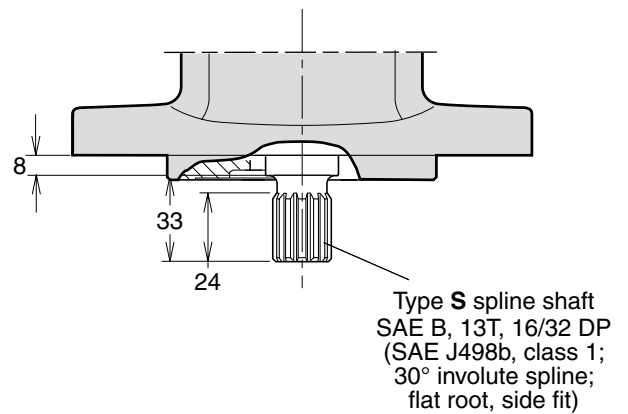
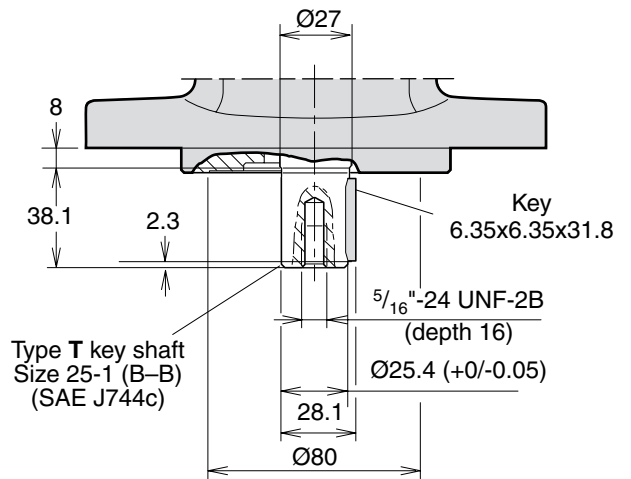

F11-019
 (SAE version)

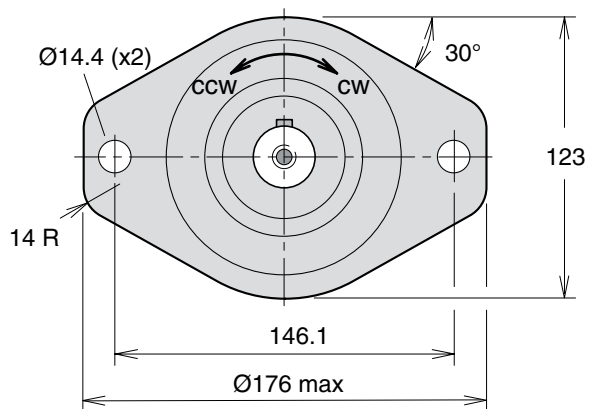

Type S mounting flange SAE 'B' (SAE J744c)

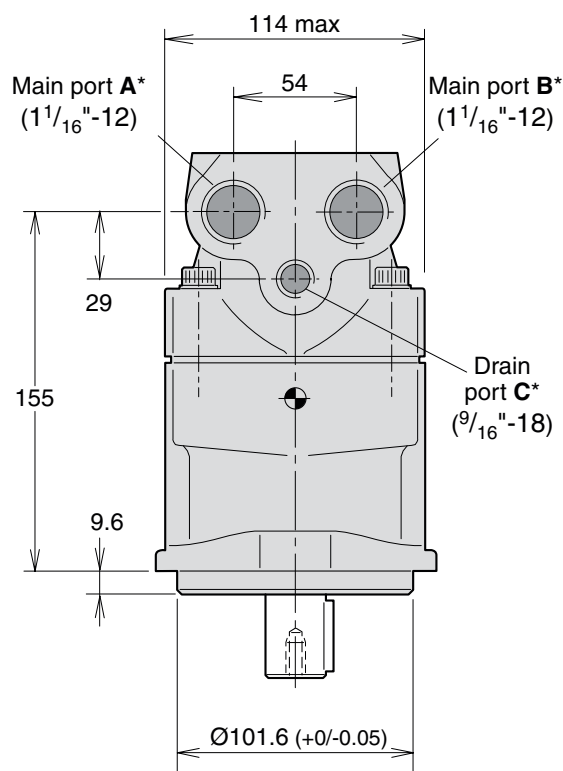
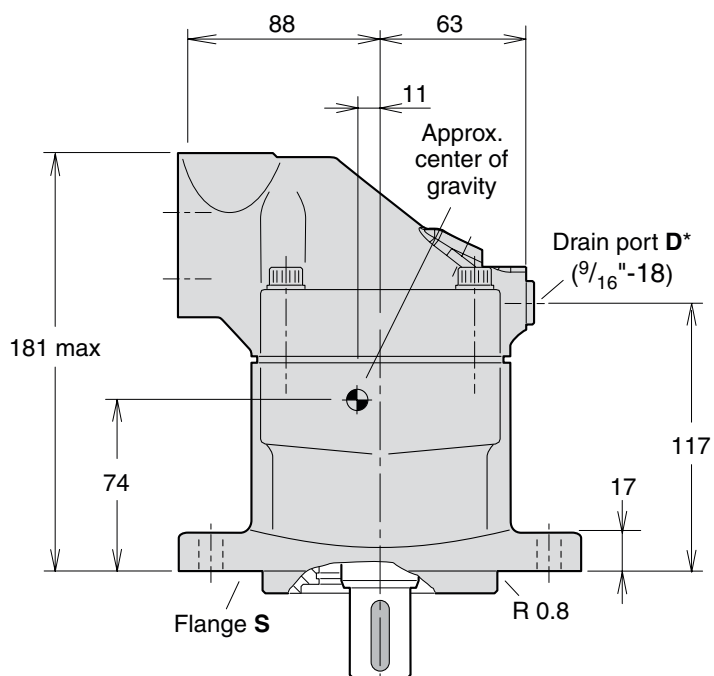

* O-ring ports according to SAE J514d

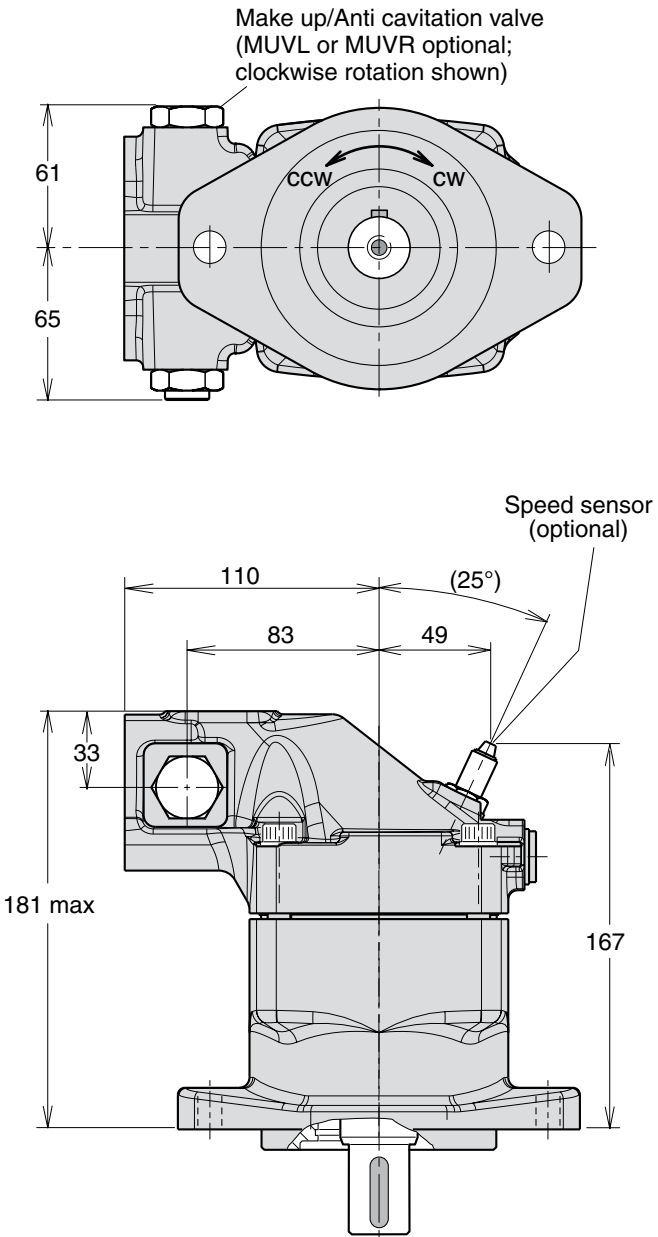

Shaft options

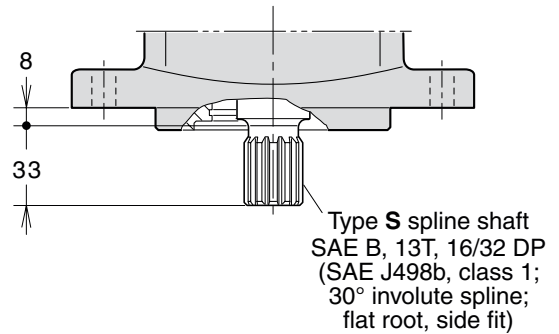
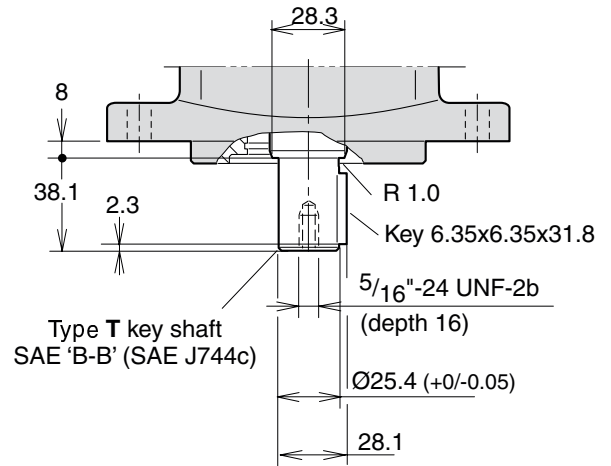

2

F12



3

Content	Page
Specifications	40
Efficiency	41
Noise level	41
Selfpriming speed and required inlet pressure	42
Ordering codes	
F12-ISO	43
F12-Cartridge	44
F12-SAE	45
Installation dimensions ISO	
F12-30, -40, -60, -80, -90, -110 and -125	46
F12-152, -162 and -182	48
Installation dimensions Cartridge	
F12-30, -40, -60, -80, -90, -110 and -125	50
Installation dimensions SAE	
F12-30, -40, -60, -80, -90, -110 and -125, 4 bolt flange	52
F12-152, -162 and -182	54
F12-250	56
F12-250 Options (SAE version)	57
F12-30, -40, and -60, 2 bolt flange	58

Frame size F12	-030	-040	-060	-080	-090	-110	-125	-152	-162	-182	-250
Displacement [cm ³ /rev]	30.0	40.0	59.8	80.4	93.0	110.1	125.0	149.8	163.1	179.8	242
Operating pressure											
max intermittent ¹⁾ [bar]	480	480	480	480	420	480	480	480	480	480	420
max continuous [bar]	420	420	420	420	350	420	420	420	420	420	350
Motor operating speed [rpm]											
max intermittent ¹⁾	8600	6700	5800	5300	5000	4800	4600	4000	4000	4000	3000
max continuous ³⁾	6700	6100	5300	4800	4600	4400	4200	3700	3700	3700	2700
min continuous	50	50	50	50	50	50	50	50	50	50	50
Max pump selfpriming speed ²⁾											
L or R function; max [rpm]	3150	2870	2500	2300	2250	2200	2100	1700	1600	1500	1500
Motor input flow											
max intermittent ¹⁾ [l/min]	219	268	347	426	465	528	575	608	648	728	726
max continuous [l/min]	201	244	317	386	428	484	525	547	583	655	653
Drain temperature ³⁾ , max [°C]	115	115	115	115	115	115	115	115	115	115	115
min [°C]	-40	-40	-40	-40	-40	-40	-40	-40	-40	-40	-40
Theoretical torque at 100 bar [Nm]	47.6	63.5	94.9	127.6	147.6	174.8	198.4	241	257	289	384.1
Mass moment of inertia											
(x10 ⁻³) [kg m ²]	1.7	2.9	5	8.4	8.4	11.2	11.2	21	21	21	46
Weight [kg]	11.5	15.7	18.6	25.7	25.7	33	33	40	40	40	77

- 1) Intermittent: max 6 seconds in any one minute.
2) Selfpriming speed valid at sea level. Find more info on page 42
3) See also installation information. Page 69

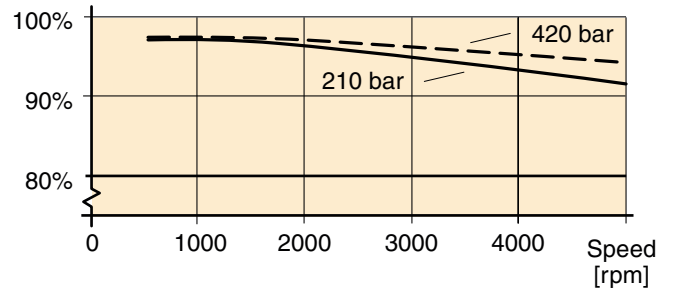
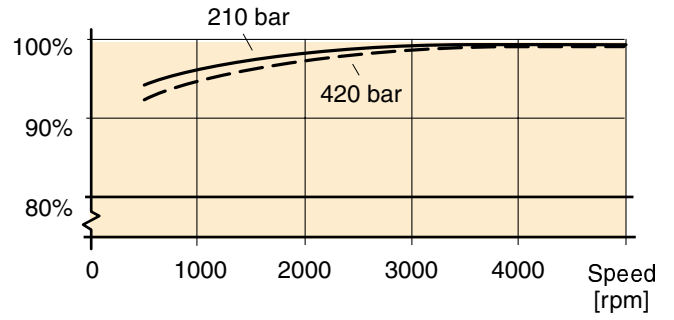

3

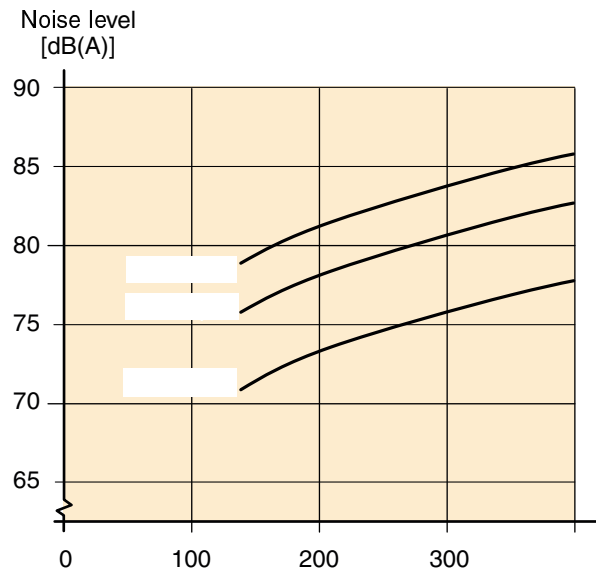

Hydraulic motor/pump Series F12

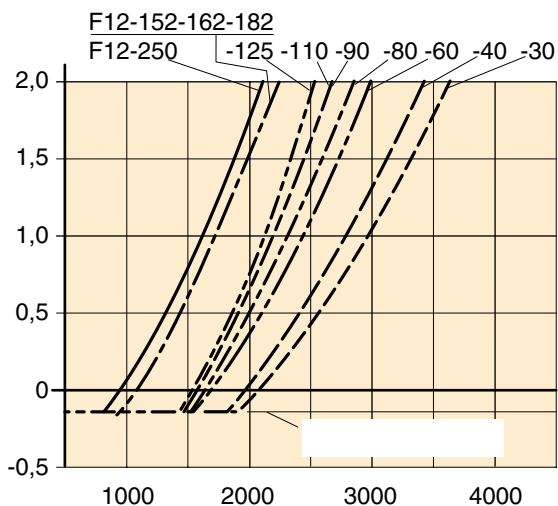
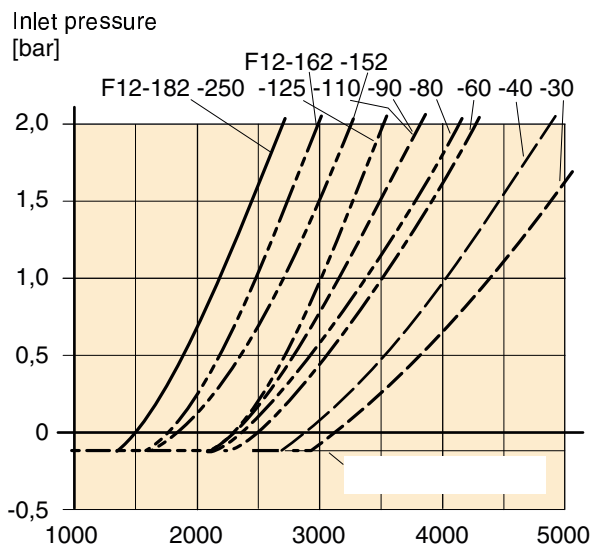

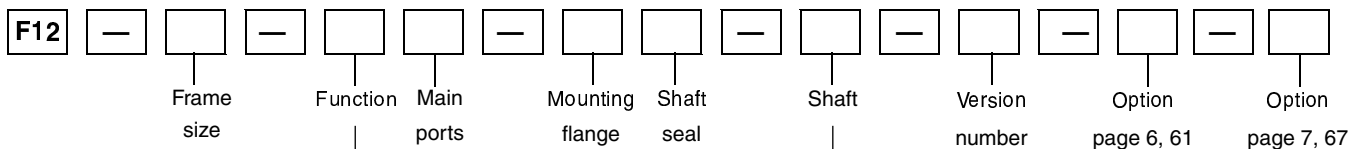

Frame size	
Code	Displacem. (cm ³ /rev)
030	30.0
040	40.0
060	59.8
080	80.4
090	93.0
110	110.1
125	125.0
152	149.8
162	163.1
182	179.8

Frame size	30	40	60	80	90	110	125	152	162	182
Code	Function									
M	Motor	x	x	x	x	x	x	x	x	x
S	Motor, high speed	(x)	(x)	(x)	-	-	-	(x)	(x)	(x)
R	Pump, clockwise rotation	(x)	(x)	(x)	(x)	(x)	(x)	(x)	(x)	(x)
L	Pump, counter clockwise rot'n	(x)	(x)	(x)	(x)	(x)	(x)	(x)	(x)	(x)

For other versions, contact Parker Hannifin

Frame size	30	40	60	80	90	110	125	152	162	182
Code	Main ports									
F	SAE 6000 psi flange	x	x	x	x	x	x	x	x	x
D	SAE 6000 psi Horizontal	-	-	-	-	-	-	(x)	(x)	(x)
A	SAE 6000 psi Axial	-	-	-	-	-	-	(x)	(x)	(x)
K	SAE 6000 psi Rear	-	-	-	-	-	-	(x)	(x)	(x)
M	SAE 6000 psi Side	-	-	-	-	-	-	(x)	(x)	(x)

Frame size	30	40	60	80	90	110	125	152	162	182
Code	Mounting flange									
I	ISO flange	x	x	x	x	x	x	x	x	x
F	ISO 200 flange	-	-	-	-	-	-	x	x	x

Version number
(assigned for special versions)

Frame size	30	40	60	80	90	110	125	152	162	182
Code	Shaft*									
D	DIN Spline, Standard	x	x	x	x	x	x	x	x	x
A	DIN Spline, Optional	-	(x)	-	-	-	-	-	-	-
Z	DIN Spline, Optional	(x)	(x)	(x)	(x)	(x)	(x)	(x)	(x)	(x)
K	Metric key, Standard	x	x	x	x	x	x	x	x	x
J	Metric key, Optional	-	(x)	-	-	-	-	-	-	-
H	DIN Spline, Optional	-	-	-	-	-	-	(x)	(x)	(x)
G	Metric key, Optional	-	-	-	-	-	-	(x)	(x)	(x)
P	Metric key, Optional	(x)	-	-	-	-	-	(x)	(x)	(x)
V	Tapered shaft	(x)	(x)	(x)	-	-	(x)	(x)	-	-

*See also dimensional drawings on pages 46 and 48.

Frame size	30	40	60	80	90	110	125	152	162	182
Code	Option									
0000	Standard	x	x	x	x	x	x	x	x	x
L130	Flushing valve 1.3 mm orifice	(x)	(x)	(x)	(x)	(x)	- ¹⁾	- ¹⁾	-	-
MUVR	Make up/Anti cavitation valve clockwise rotation	(x)	-	-	-	-	-	-	-	-
MUVL	Make up/Anti cavitation valve counter clockwise rotation	(x)	-	-	-	-	-	-	-	-
P ₂₎ R	Pressure relief valve clockwise rotation	(x)	(x)	(x)	-	-	-	-	-	-
P ₂₎ L	Pressure relief valve counter clockwise rotation	(x)	(x)	(x)	-	-	-	-	-	-

Frame size	30	40	60	80	90	110	125	152	162	182
Code	Option									
P0	Prepared for speed sensor	x	x	x	x	x	x	x	x	x
PT	Prepared for speed sensor and Painted Black	(x)	(x)	(x)	(x)	(x)	(x)	(x)	(x)	(x)
B0	Power Boost and Prepared for speed sensor	(x)	-	-	-	-	-	-	-	-
BT	Power Boost, Prepared for speed sensor and Painted Black	(x)	-	-	-	-	-	-	-	-

Frame size	30	40	60	80	90	110	125	152	162	182
Code	Shaft seal									
V	FPM, high pressure, high temperature	x	x	x	x	x	x	x	x	x

For other versions, contact Parker Hannifin

NOTE: All combinations are not valid, please contact Parker Hannifin



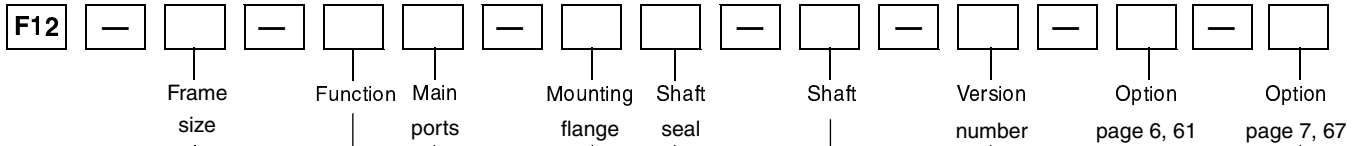

F12-Cartridge

Frame size	
Code	Displacem. (cm ³ /rev)
030	30.0
040	40.0
060	59.8
080	80.4
090	93.0
110	110.1
125	125.0

Version number
(assigned for special versions)

Frame size	30	40	60	80	90	110	125
Code Shaft*							
C	DIN Spline, Std.	x	x	x	x	x	x
K	Metric key, Option	(x)	-	(x)	(x)	(x)	(x)
J	Metric key, Option	-	(x)	-	-	-	-
B	Spline DIN 5480	-	-	(x)	-	-	(x)
V	Tapered shaft	(x)	(x)	(x)	-	-	(x)

*See also dimensional drawings on page 50.

Frame size	30	40	60	80	90	110	125
Code Function							
M	Motor	x	x	x	x	x	x
S	Motor, high speed	(x)	(x)	(x)	-	-	-

For other versions, contact Parker Hannifin

Frame size	30	40	60	80	90	110	125
Code Option							
0000	Standard	x	x	x	x	x	x
L130	Flushing valve 1.3 mm orifice	(x)	(x)	(x)	(x)	(x)	(x)
MUVR	Make up/Anti cavitation valve clockwise rotation	(x)	-	-	-	-	-
MUVL	Make up/Anti cavitation valve counter clockwise rotation	(x)	-	-	-	-	-
P ₂ R	Pressure relief valve clockwise rotation	(x)	(x)	(x)	-	-	-
P ₂ L	Pressure relief valve counter clockwise rotation	(x)	(x)	(x)	-	-	-

Frame size	30	40	60	80	90	110	125
Code Main ports							
F	SAE 6000 psi flange	x	x	x	x	x	x

Frame size	30	40	60	80	90	110	125
Code Mounting flange							
C	Cartridge	x	x	x	x	x	x

Frame size	30	40	60	80	90	110	125
Code Option							
P0	Prepared for speed sensor	x	x	x	x	x	x
PT	Prepared for speed sensor and Painted Black	(x)	(x)	(x)	(x)	(x)	(x)
B0	Power Boost and Prepared for speed sensor	(x)	-	-	-	-	-
BT	Power Boost, Prepared for speed sensor and Painted Black	(x)	-	-	-	-	-

- x : Available (x): Optional - : Not available
 1) F12-110 and -125: Accessory valve block (page 62)
 2) Pressure setting on page 63

NOTE: All combinations are not valid, please contact Parker Hannifin

Frame size	30	40	60	80	90	110	125
Code Shaft seal							
V	FPM, high pressure, high temperature	x	x	x	x	x	x

For other versions, contact Parker Hannifin

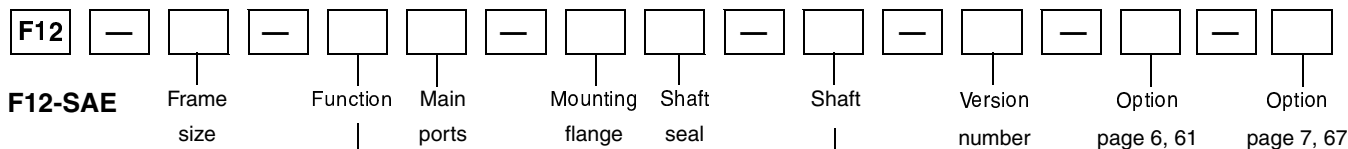

Frame size	
Code	Displacem. (cm ³ /rev)
030	30.0
040	40.0
060	59.8
080	80.4
090	93.0
110	110.1
125	125.0
152	149.8
162	163.1
182	179.8
250	242.0

Version number	
(assigned for special versions)	

Frame size	30	40	60	80	90	110	125	152	162	182	250	
Code	Function											
M	Motor	x	x	x	x	x	x	x	x	x	x	-
S	Motor, high speed	(x)	(x)	(x)	-	-	-	(x)	(x)	(x)	-	-
Q	Motor	-	-	-	-	-	-	-	-	-	-	x
R	Pump, clockwise rotation	(x)	(x)	(x)	(x)	(x)	(x)	(x)	(x)	(x)	(x)	(x)
L	Pump, counter clockwise rot'n	(x)	(x)	(x)	(x)	(x)	(x)	(x)	(x)	(x)	(x)	(x)

For other versions, contact Parker Hannifin

Frame size	30	40	60	80	90	110	125	152	162	182	250	
Code	Main ports											
S	SAE 6000 psi flange	x	x	x	x	x	x	-	-	-	-	-
U	SAE UN threads ⁴⁾	(x)	(x)	(x)	(x)	(x)	(x)	-	-	-	-	-
F	SAE 6000 psi flange ²⁾	-	-	-	-	-	-	x	x	x	x	x
D	SAE 6000 psi Horizontal ²⁾	-	-	-	-	-	-	(x)	(x)	(x)	-	-
A	SAE 6000 psi Axial ²⁾	-	-	-	-	-	-	(x)	(x)	(x)	-	-
K	SAE 6000 psi Rear ²⁾	-	-	-	-	-	-	(x)	(x)	(x)	-	-
M	SAE 6000 psi Side ²⁾	-	-	-	-	-	-	(x)	(x)	(x)	-	-

Frame size	30	40	60	80	90	110	125	152	162	182	250	
Code	Mounting flange											
S	SAE 4 bolt	x	x	x	x	x	x	x	x	x	x	x
R	SAE 4 bolt	-	-	-	(x)	(x)	-	-	-	-	-	-
T	SAE 2 bolt	x	x	x	-	-	-	-	-	-	-	-

Frame size	30	40	60	80	90	110	125	152	162	182	250	
Code	Shaft*											
T	SAE key, Standard	x	x	x	x	x	x	x	x	x	x	x
R	SAE key, Optional	-	-	-	(x)	(x)	-	-	-	-	-	-
S	SAE Spline, Optional	x	x	x	x	x	x	x	x	x	x	x
F	SAE Spline, Optional	-	-	-	(x)	(x)	-	-	(x)	(x)	(x)	(x)
U	SAE Spline, Optional	-	-	-	(x)	(x)	-	-	-	-	-	-
K	Metric key, Standard	-	-	-	-	-	-	-	-	-	-	x
D	Spline DIN 5480	-	-	-	-	-	-	-	-	-	-	(x)
V	Tapered shaft	(x)	(x)	(x)	-	-	(x)	(x)	-	-	-	-

*See also dimensional drawings on pages 52 - 59.

Frame size	30	40	60	80	90	110	125	152	162	182	250	
Code	Option											
0000	Standard	x	x	x	x	x	x	x	x	x	x	x
L130	Flushing valve 1.3 mm orifice	(x)	(x)	(x)	(x)	(x)	⁻¹⁾	⁻¹⁾	-	-	-	-
MUVR	Make up/Anti cavitation valve clockwise rotation	(x)	-	-	-	-	-	-	-	-	-	-
MUVR	Make up/Anti cavitation valve counter clockwise rotation	(x)	-	-	-	-	-	-	-	-	-	-
P ₃₎ R	Pressure relief valve clockwise rotation	(x)	(x)	(x)	-	-	-	-	-	-	-	-
P ₃₎ L	Pressure relief valve counter clockwise rotation	(x)	(x)	(x)	-	-	-	-	-	-	-	-

Frame size	30	40	60	80	90	110	125	152	162	182	250	
Code	Option											
P ₋	Standard, prepared for speed sensor	x	x	x	x	x	x	x	x	x	x	x
B ₋	Power Boost and Prepared for speed sensor	(x)	-	-	-	-	-	-	-	-	-	-
_T	Painted Black	(x)	(x)	(x)	(x)	(x)	(x)	(x)	(x)	(x)	(x)	(x)

Frame size	30	40	60	80	90	110	125	152	162	182	250	
Code	Shaft seal											
V	FPM, high pressure, high temperature	x	x	x	x	x	x	x	x	x	x	x

NOTE: All combinations are not valid, please contact Parker Hannifin

For other versions, contact Parker Hannifin



F12-30, -40, -60, -80, -90, -110 and -125
 (ISO versions)

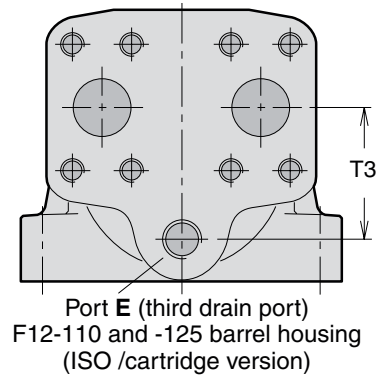
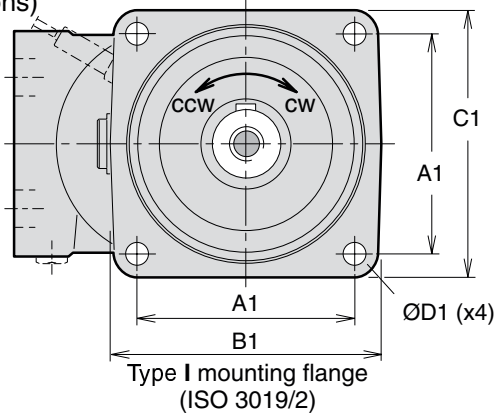

F12-80 shown

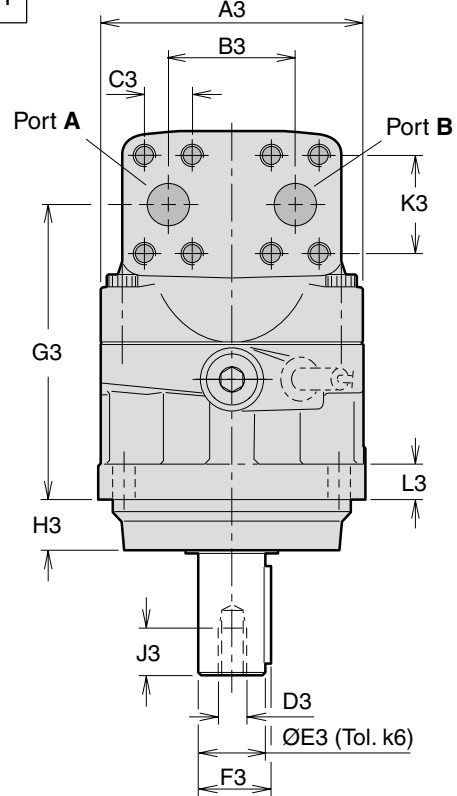
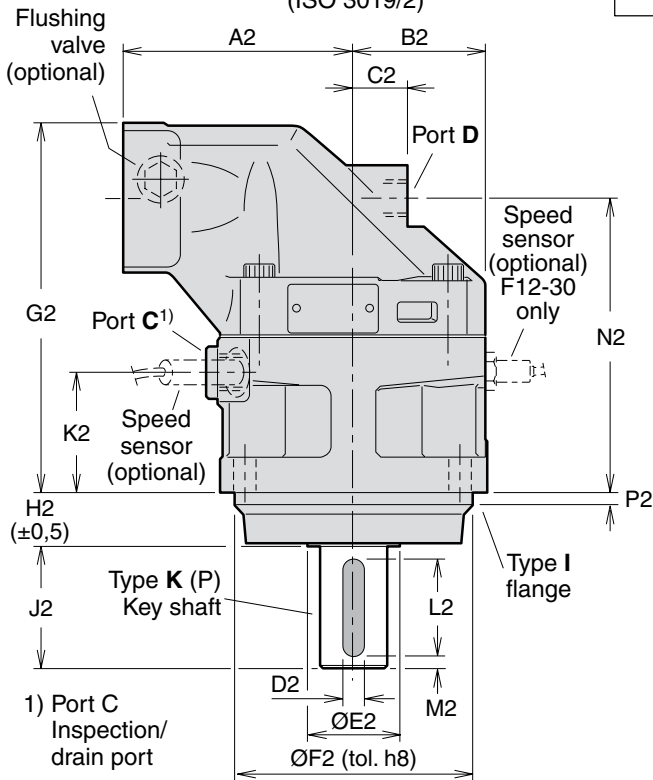

Shaft option D (Z)

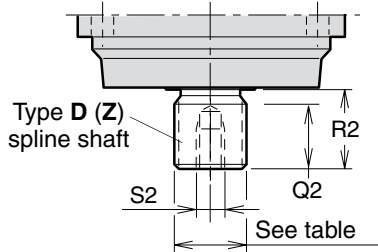

Shaft option V (F12-30)

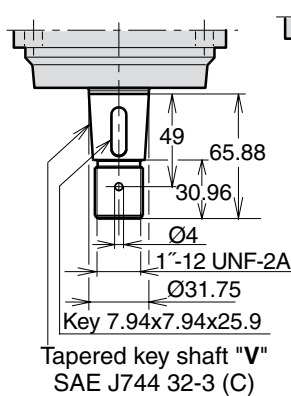

Shaft option V (F12-40)

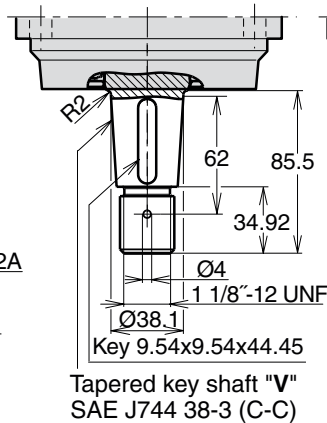

Shaft option V (F12-60)

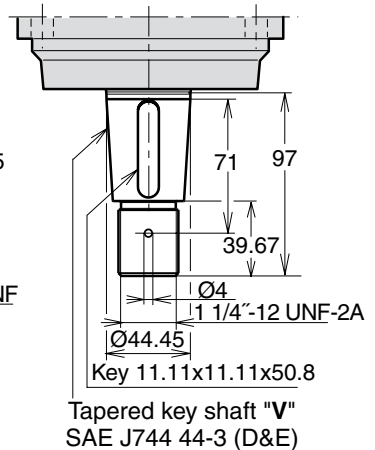

Dim.	F12-30	F12-40	F12-60	F12-80 F12-90	F12-110 F12-125
A1	88.4	113.2	113.2	127.2	141.4
B1	118	146	146	158	180
C1	118	142	144	155	180
D1	11	13.5	13.5	13.5	18
A2	100	110	125	135	145
B2	59	65	70	78	85
C2	25	26	22	32	38
D2	8	8	10	12	14
E2	33	42	42	52	58
F2	100	125	125	140	160
G2	172	173	190	216	231
H2	25.5	32.5	32.5	32.5	40.5
J2	50	60	60	70	82
K2	55	52	54	70.5	66.5
L2	40	50	50	56	70
M2	5	5	5	7	6
N2	136.5	137	154	172.5	179
P2	8	8	8	8	8
Q2	28	28	33	36	41
R2 ¹⁾	35	35	40	45	50
R2 ²⁾	43	35	35	35	45
S2 ¹⁾	M12 x24	M12 x24	M12 x28	M16 x36	M16 x36
S2 ²⁾	no thread	M12 x24	no thread	M12 x28	M16 x36
A3	122	134	144	155	170
B3	66	66	66	75	83
C3	23.8	23.8	23.8	27.8	31.8
D3	M12	M12	M12	M16	M16
E3	30	30	35	40	45
F3	33	33	38	43	49
G3	136.5	137	154	172.5	179
H3	23.5	30.5	30.5	30.5	38.5
J3	24	24	28	36	36
K3	50.8	50.8	50.8	57.2	66.7
L3	18	20	20	20	22
T3	-	-	-	-	68

- 1) Spline shaft type D
- 2) Spline shaft type Z
- 3) Max operating pressure 350 bar

Ports	F12-30	F12-40	F12-60	F12-80 F12-90	F12-110 F12-125
A, B size	3/4"	3/4"	3/4"	1"	1 1/4"
Screw thread ^{*)}	M10 x20	M10 x20	M10 x20	M12 x20	M14 x26
C thread ^{**)}	M22 x1.5	M22 x1.5	M22 x1.5	M22 x1.5	M22 x1.5
D thread ^{**)}	M18 x1.5	M18 x1.5	M22 x1.5	M22 x1.5	M22 x1.5
E thread	-	-	-	-	M22 x1.5

A, B: ISO 6162 ^{*)} Metric thread x depth in mm
^{**)} Metric thread x pitch in mm.

	Type D (std)	Type A	Type Z (optional)
F12-30	W30x2x14x9g	-	W25x1.25x18x9g ³⁾
-40	W32x2x14x9g	W35x2x16x9g	W30x2x14x9g
-60	W35x2x16x9g	-	W32x2x14x9g
-80	W40x2x18x9g	-	W35x2x16x9g ³⁾
-90	W40x2x18x9g	-	W35x2x16x9g ³⁾
-110	W45x2x21x9g	-	W40x2x18x9g ³⁾
-125	W45x2x21x9g	-	W40x2x18x9g ³⁾

	Type K (std)	Type P (opt.)	Type J (opt.)	Type V (opt.)
F12-30	Ø30	Ø25 ³⁾	-	32-3
-40	Ø30	-	Ø35	38-3
-60	Ø35	-	-	44-3
-80	Ø40	-	-	-
-90	Ø40	-	-	-
-110	Ø45	-	-	44-3
-125	Ø45	-	-	44-3

F12-152, -162 and -182
 (ISO versions)

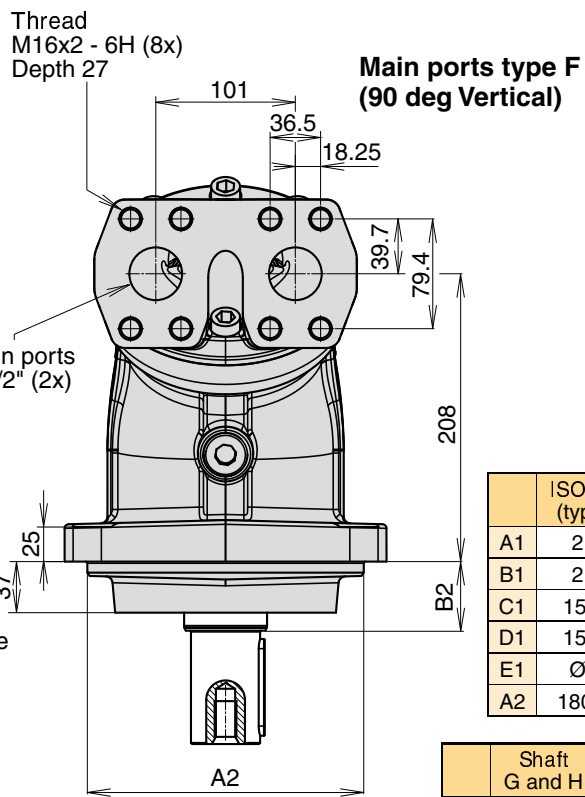
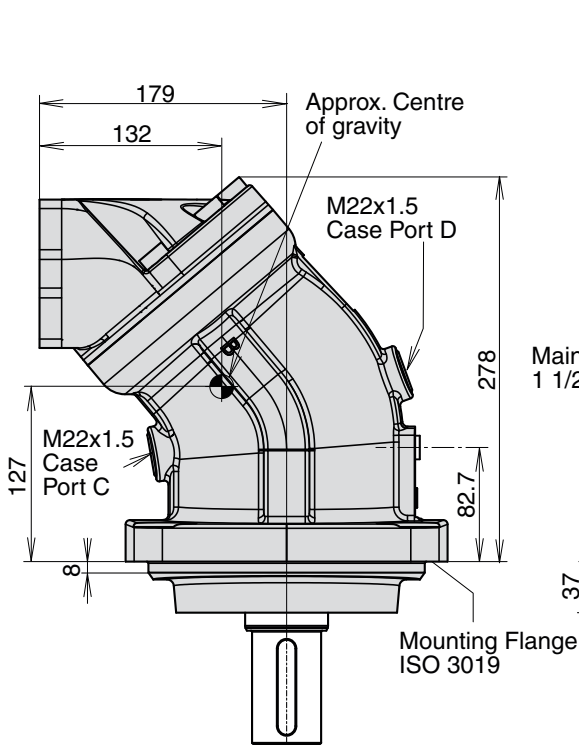
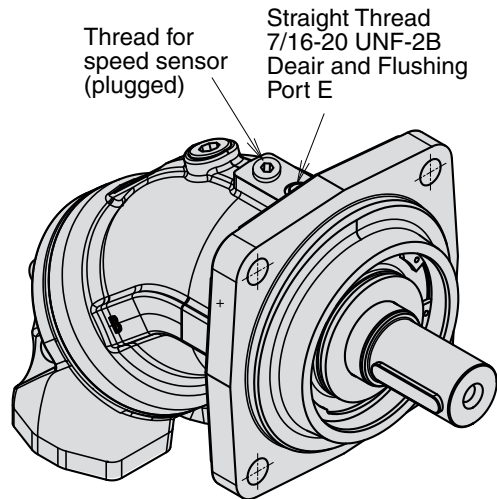
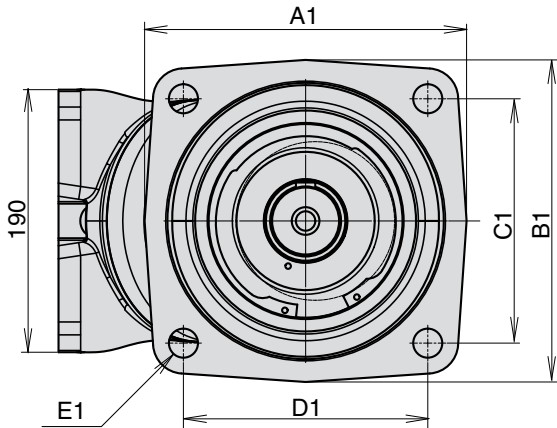

	ISO 180 (type I)	ISO 200 (type F)
A1	210	233
B1	210	233
C1	158.4	176.8
D1	158.4	176.8
E1	Ø18	Ø21
A2	180 h8	200 h8

	Shaft G and H	Shaft D, Z, K and P
B2	50	40

Shaft options K and G

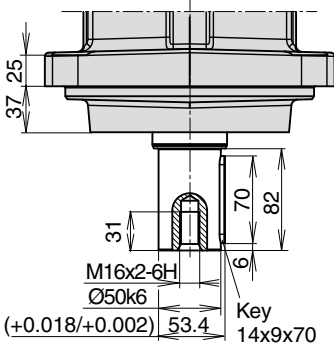

Shaft option P

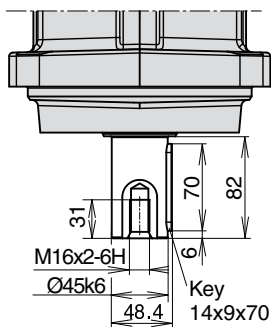

Shaft option D

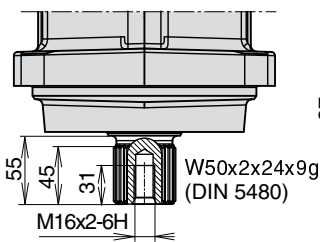

Shaft options Z and H

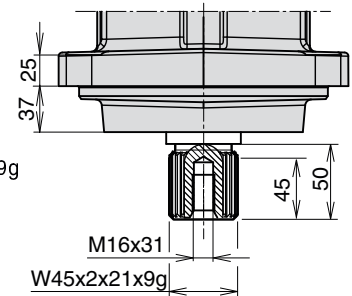

F12-152, -162 and -182
 (ISO versions)

Main ports type A
 (180 deg Vertical)

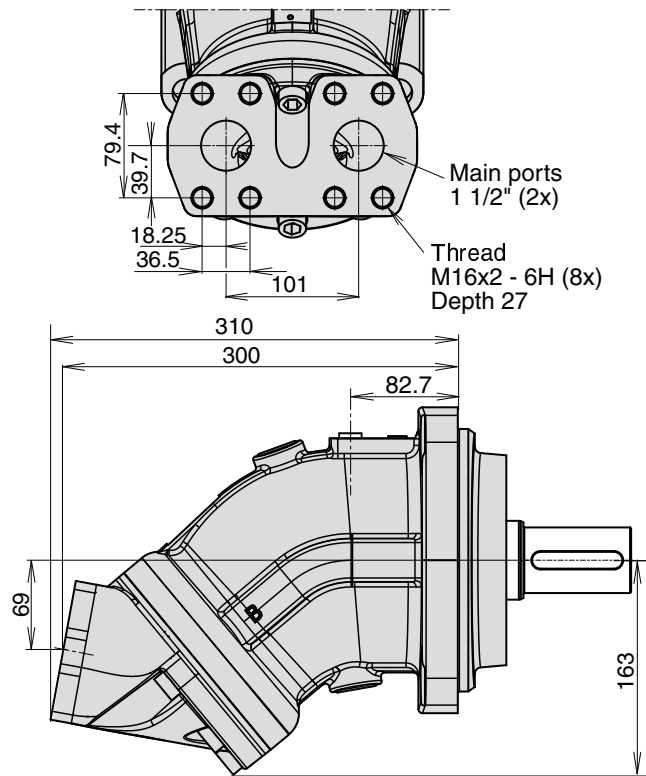

Main ports type D
 (90 deg Horizontal)

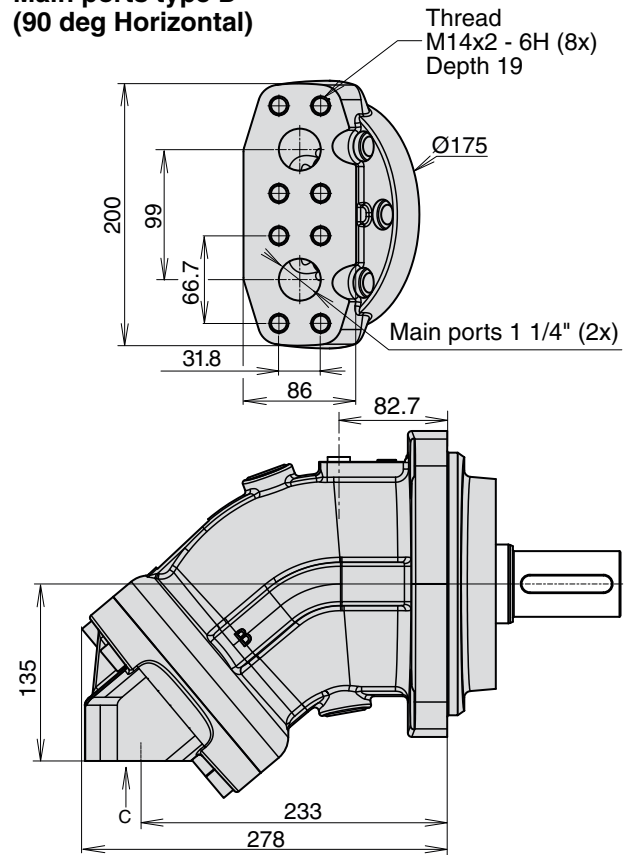

3

Main ports type K
 (40 deg rear)

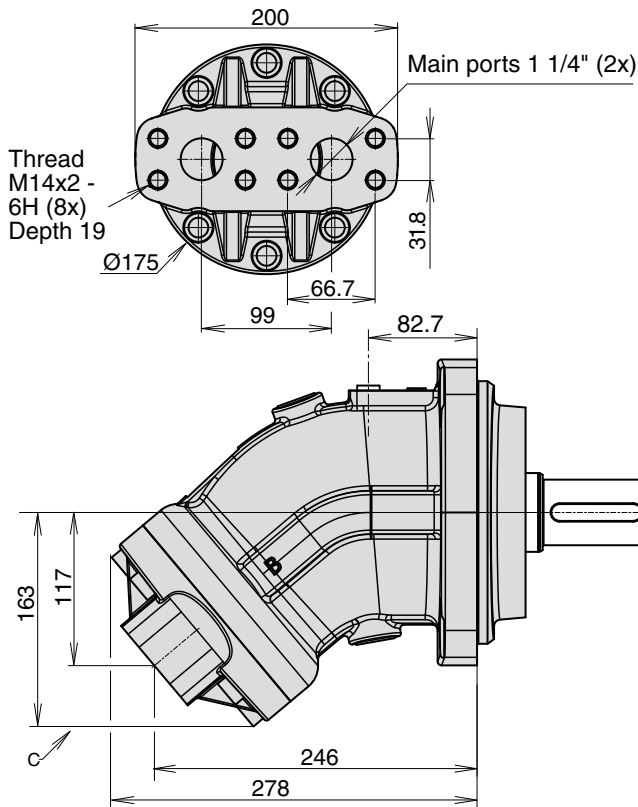

Main ports type M
 (Side ports)

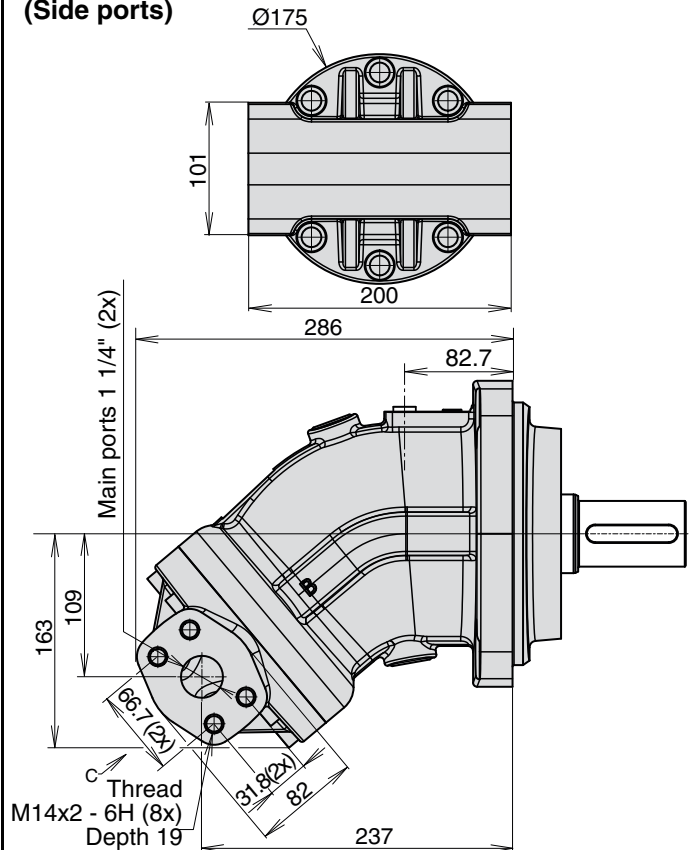

F12-30, -40, -60, -80, -90, -110 and -125
 (Cartridge versions)

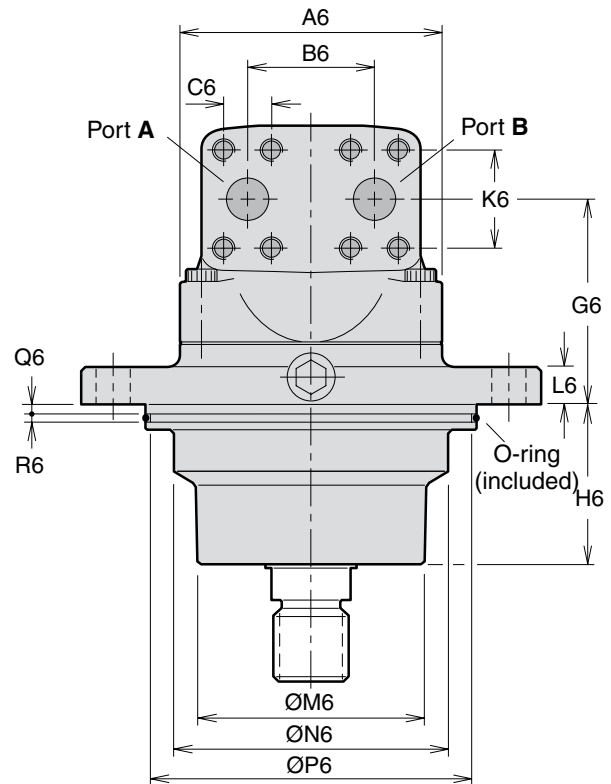
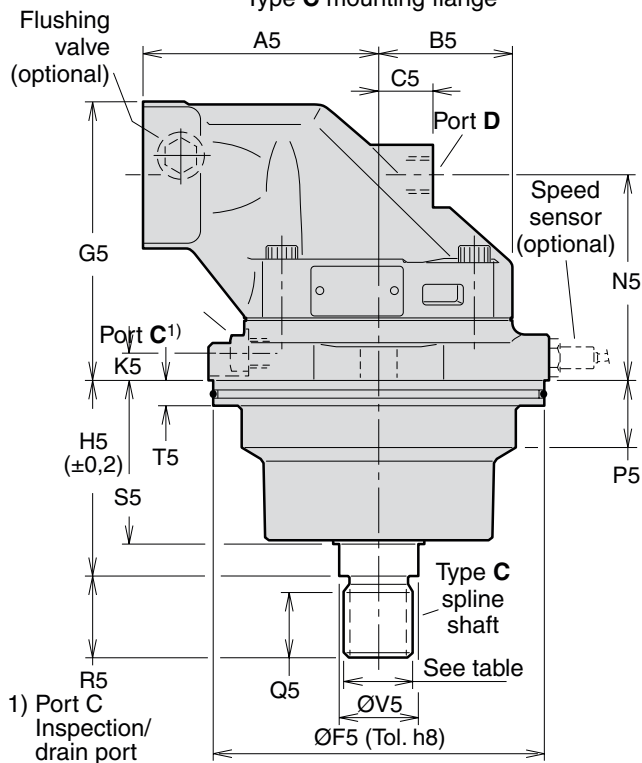
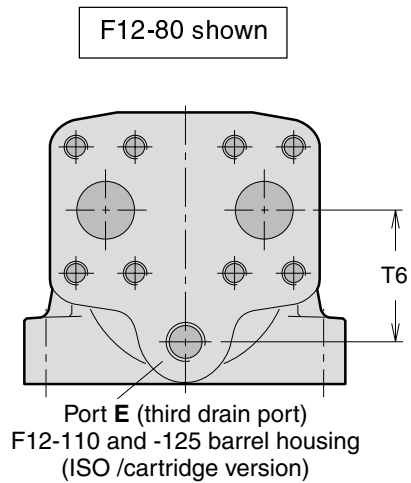
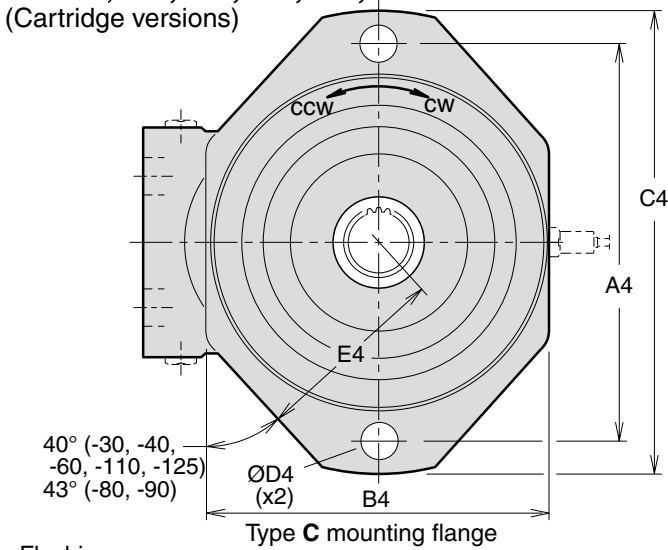

1) Port C
 Inspection/
 drain port

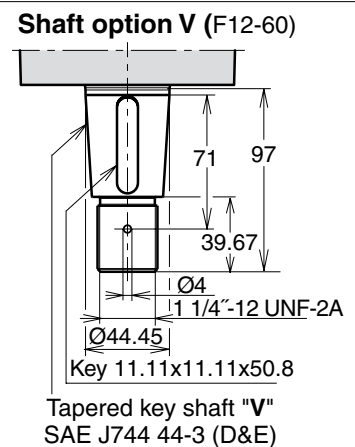
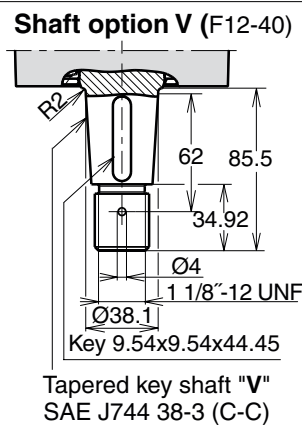
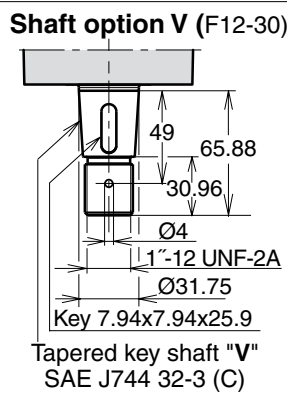
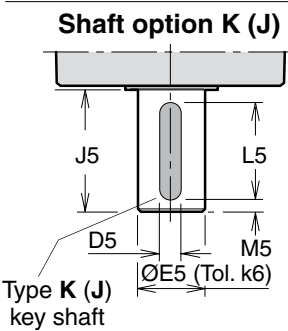

Dim.	F12-30	F12-40	F12-60	F12-80 F12-90	F12-110 F12-125
A4	160	200	200	224	250
B4	140	164	164	196	206
C4	188	235	235	260	286
D4	14	18	18	22	22
E4	77	95	95	110	116
A5	100	110	125	135	145
B5	59	65	70	77.5	85
C5	25	26	22	32	38
D5	8	8 ¹⁾ 10 ²⁾	10	12	14
E5	30	30 ¹⁾ 35 ²⁾	35	40	45
F5	135	160	160	190	200
G5	127	133	146	157	175
H5	89	92.3	92.3	110.5	122.8
J5	50	60	60	70	82
K5	14	16	15	15	15
L5	40	50	50	56	70
M5	5	5	5	7	6
N5	91	97	110	114	123
P5	22	30	31	40	40
Q5	28	28	28	37	37
R5	35	35	35	45	45
S5	70.5	72	76	91	95.7
T5	15	15	15	15	15
V5	32	35	35	45	45
A6	122	134	144	155	170
B6	66	66	66	75	83
C6	23.8	23.8	23.8	27.8	31.8
G6	91.5	97	110	114	123
H6	69.5	71	74	89.5	93.7
K6	50.8	50.8	50.8	57.2	66.7
L6	16	18	18	20	20
M6	92	115	115	130	140
N6	110	127	135	154	160
P6	128.2	153.2	153.2	183.2	193.2
Q6	5	5	5	5	5
R6	5	5	5	5	5
T6	-	-	-	-	68

- 1) Key shaft type **K**
 2) Key shaft type **J** (opt.).

Ports	F12-30	F12-40	F12-60	F12-80 F12-90	F12-110 F12-125
A, B size	3/4"	3/4"	3/4"	1"	1 1/4"
Screw thread	M10 x20	M10 x20	M10 x20	M12 x22	M14 x26
C thread	M14 x1.5	M14 x1.5	M14 x1.5	M14 x1.5	M14 x1.5
D, E thread	M18 x1.5	M18 x1.5	M22 x1.5	M22 x1.5	M22 x1.5

A, B: ISO 6162

Spline shaft (DIN 5480)

	Type C (standard)	Type B (optional)
F12-30	W30x2x14x9g	-
-40	W30x2x14x9g	-
-60	W30x2x14x9g	W35x2x16x9g
-80	W40x2x18x9g	-
-90	W40x2x18x9g	-
-110	W40x2x18x9g	W45x2x21x9g
-125	W40x2x18x9g	W45x2x21x9g

Key shaft

	Type K (std)	Type J (opt.)	Type V (opt.)
F12-30	Ø30	-	32-3
-40	Ø30	Ø35	38-3
-60	Ø35	-	44-3
-80	Ø40	-	-
-90	Ø40	-	-
-110	Ø45	-	44-3
-125	Ø45	-	44-3

O-ring dimensions

F12-30	127x4
-40	150x4
-60	150x4
-80	180x4
-90	180x4
-110	190x4
-125	190x4

F12-30, -40, -60, -80, -90, -110 and -125
 (SAE versions with 4 bolt flange)

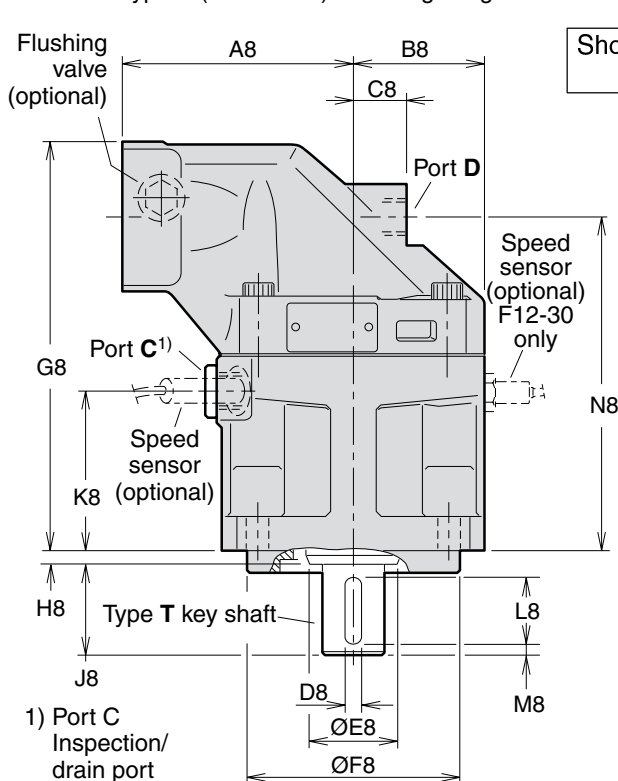
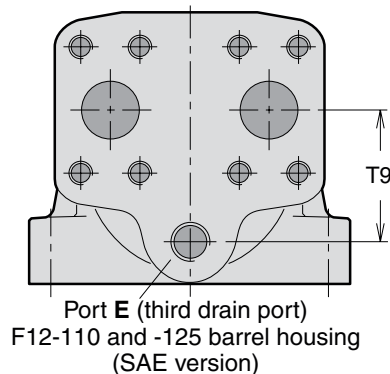
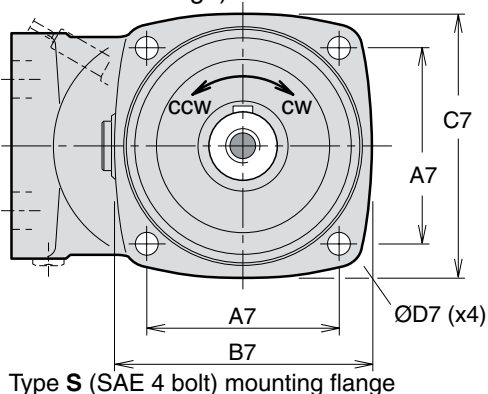

Shown: F12-80 with 4 bolt flange

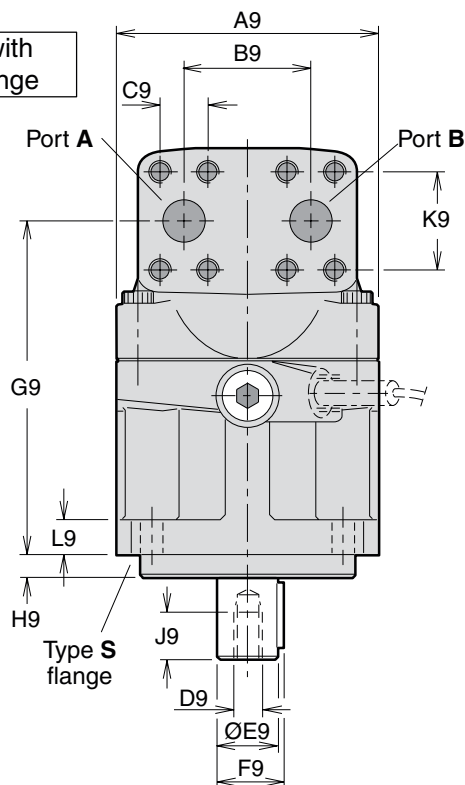

Shaft option S (U)

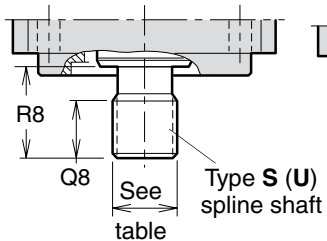

Shaft option V (F12-30)

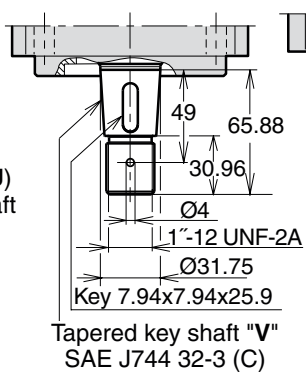

Shaft option V (F12-40)

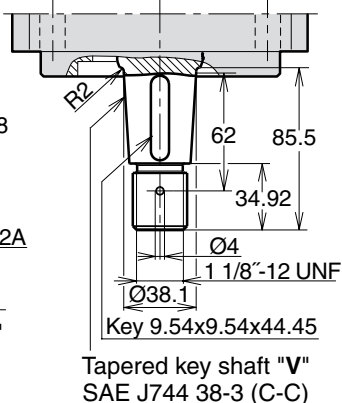

Shaft option V (F12-60)

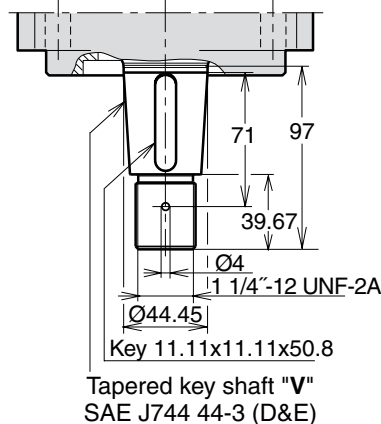

Dim.	F12-30	F12-40	F12-60	F12-80 F12-90	F12-110 F12-125
A7	89.8	114.5	114.5	114.5	161.6
B7	118	148	148	155	204
C7	118	144	144	155	200
D7	14	14	14	14	21
A8	100	110	125	135	145
B8	59	65	70	77.5	85
C8	25	26	22	32	38
D8	6.35	7.94	7.94	9.53	11.1
E8	33	42	42	52	57.5
F8	101.60/ 101.55	127.00/ 126.94	127.00/ 126.94	127.00/ 126.94	152.40/ 152.34
G8	189.5	197	214	240	264
H8	8	8	8	8	8
J8	38	48	48	54	67
K8	72	76	79	95	99
L8	31.8	38.1	38.1	44.5	54.1
M8	2.5	4	4	4	7.5
N8	153.5	161	178.3	197.1	212
Q8 ¹⁾	26	27	27	29	39
Q8 ²⁾	-	-	-	23	-
R8 ¹⁾	33	48	48	54	66.7
R8 ²⁾	-	-	-	48	-
A9	122	134	144	155	170
B9	66	66	66	75	83
C9	23.8	23.8	23.8	27.8	31.8
D9*	5/16"-24	3/8"-24	3/8"-24	1/2"-20	5/8"-18
E9	25.40/ 25.35	31.75/ 31.70	31.75/ 31.70	38.10/ 38.5	44.45/ 44.40
F9	28.2	35.3	35.3	42.3	49.4
G9	153.8	161	178.3	197.1	212
H9	9.7	12.7	12.7	12.7	12.7
J9	16	19	19	26	32
K9	50.8	50.8	50.8	57.2	66.7
L9	18	20	20	20	22
T9	-	-	-	-	68

* UNF-2B thread

1) Spline shaft type **S**

2) Spline shaft type **U**

3) Max operating pressure 350 bar

Main ports A and B, type U (optional)	
F12-30	1 1/16" - 12 UN ³⁾
F12-40	1 5/16" - 12 UN ³⁾
F12-60	1 5/16" - 12 UN ³⁾
F12-80	1 5/16" - 12 UN ³⁾
F12-90	1 5/16" - 12 UN ³⁾
F12-110	1 5/8" - 12 UN ³⁾
F12-125	1 5/8" - 12 UN ³⁾

Ports	F12-30	F12-40	F12-60	F12-80 F12-90	F12-110 F12-125
A, B size	3/4"	3/4"	3/4"	1"	1 1/4"
Screw thread**)	3/8"-16 x22	3/8"-16 x20	3/8"-16 x22	7/16"-14 x27	1/2"-13 x25
C thread	7/8"-14	7/8"-14	7/8"-14	7/8"-14	1 1/16"-12
D thread	3/4"-16	3/4"-16	7/8"-14	7/8"-14	1 1/16"-12
E thread	-	-	-	-	1 1/16"-12

A, B: ISO 6162 C, D, E: O-ring boss (SAE J514)

***) UN thread x depth in mm.

	S (standard)	R (optional)
F12-30	SAE 'B', 4 bolt	-
-40	SAE 'C', 4 bolt	-
-60	SAE 'C', 4 bolt	-
-80	SAE 'C', 4 bolt	SAE 'D', 4 bolt
-90	SAE 'C', 4 bolt	SAE 'D', 4 bolt
-110	SAE 'D', 4 bolt	-
-125	SAE 'D', 4 bolt	-

Spline shaft (SAE J498b, class 1, flat root, side fit)

	S (standard)	U (opt.)	F (optional)
F12-30	SAE 'B' 13T, 16/32 DP	-	-
-40	SAE 'C' 14T, 12/24 DP	-	-
-60	SAE 'C' 14T, 12/24 DP	-	-
-80	SAE 'C-C' 17T, 12/24 DP	SAE 'C' 14T, 12/24 DP ³⁾	SAE 'D' 13T, 8/16 DP
-90	SAE 'C-C' 17T, 12/24 DP	SAE 'C' 14T, 12/24 DP ³⁾	SAE 'D' 13T, 8/16 DP
-110	SAE 'D' 13T, 8/16 DP	-	-
-125	SAE 'D' 13T, 8/16 DP	-	-

Key shaft (SAE J744)

F12	T (standard)	R (optional)	V (optional)
-30	SAE 'B-B' (Ø25.4 mm/1")	-	32-3
-40	SAE 'C' (Ø31.75 mm/1 1/4")	-	38-3
-60	SAE 'C' (Ø31.75 mm/1 1/4")	-	44-3
-80	SAE 'C-C' (Ø38.1 mm/1 1/2")	SAE 'D' (Ø44.45 mm/1 3/4")	-
-90	SAE 'C-C' (Ø38.1 mm/1 1/2")	SAE 'D' (Ø44.45 mm/1 3/4")	-
-110	SAE 'D' (Ø44.45 mm/1 3/4")	-	44-3
-125	SAE 'D' (Ø44.45 mm/1 3/4")	-	44-3

F12-152, -162 and -182
 (SAE versions)

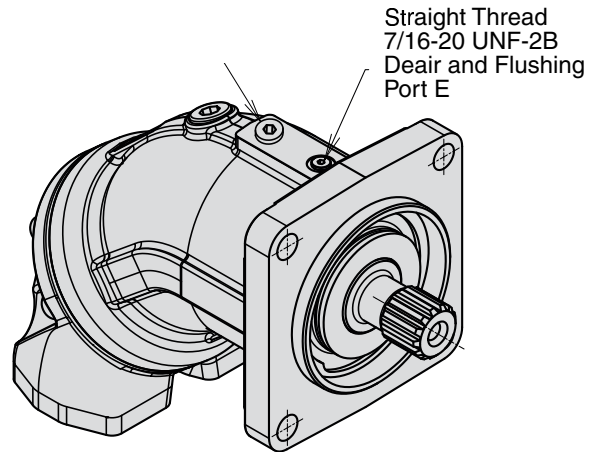
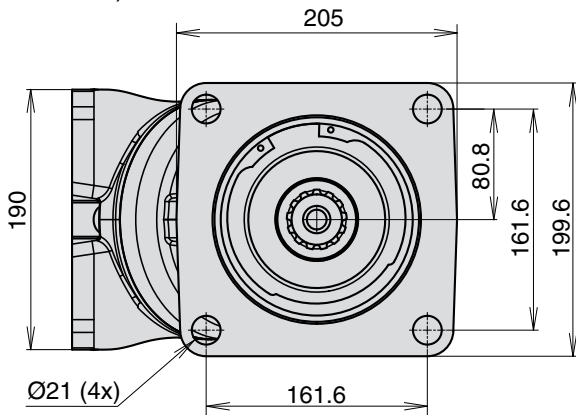

Main ports type F
 (90 deg Vertical)

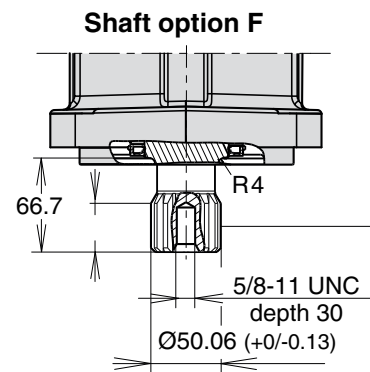
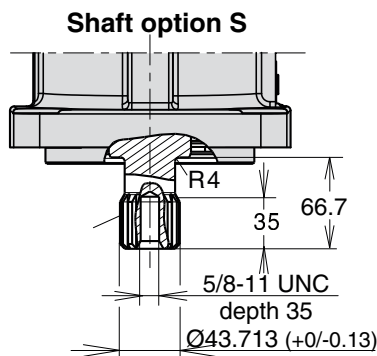
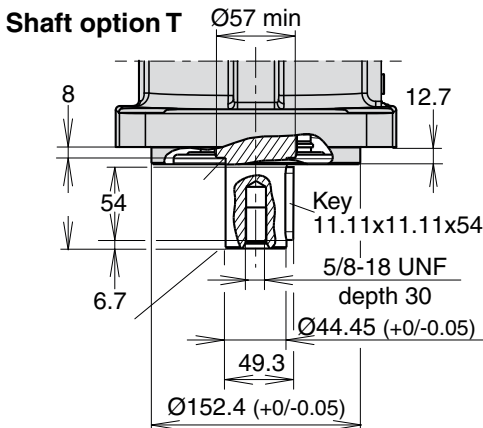
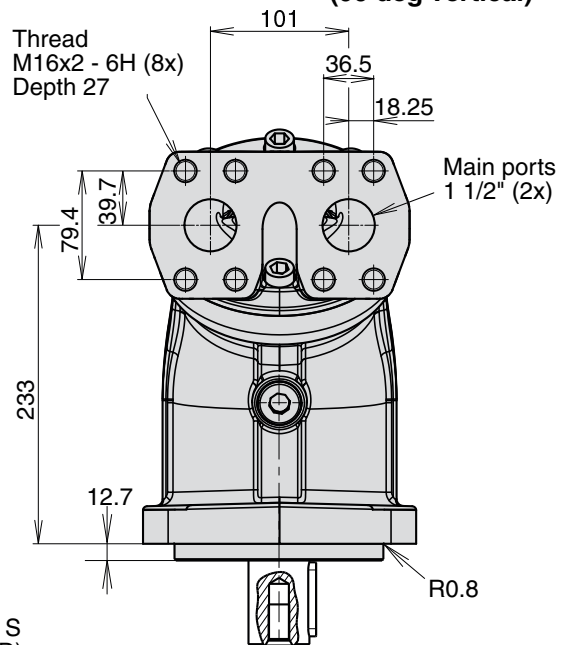
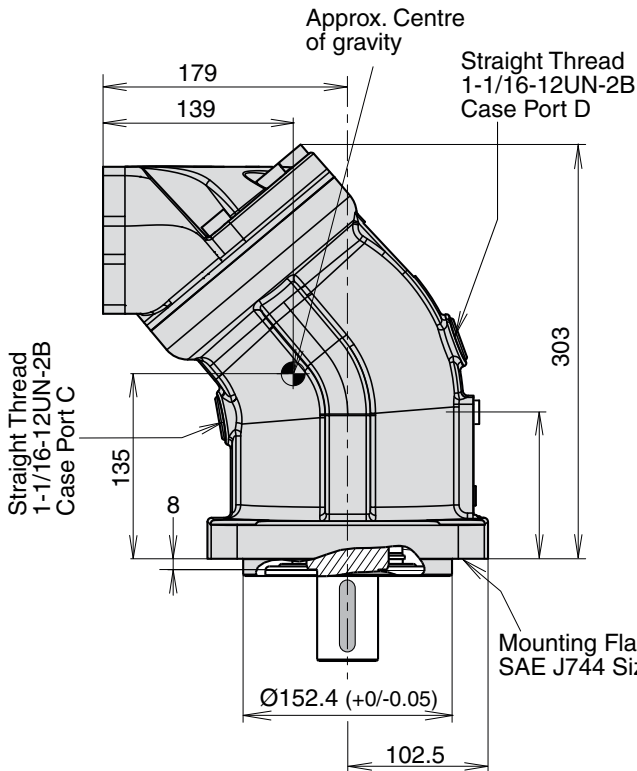

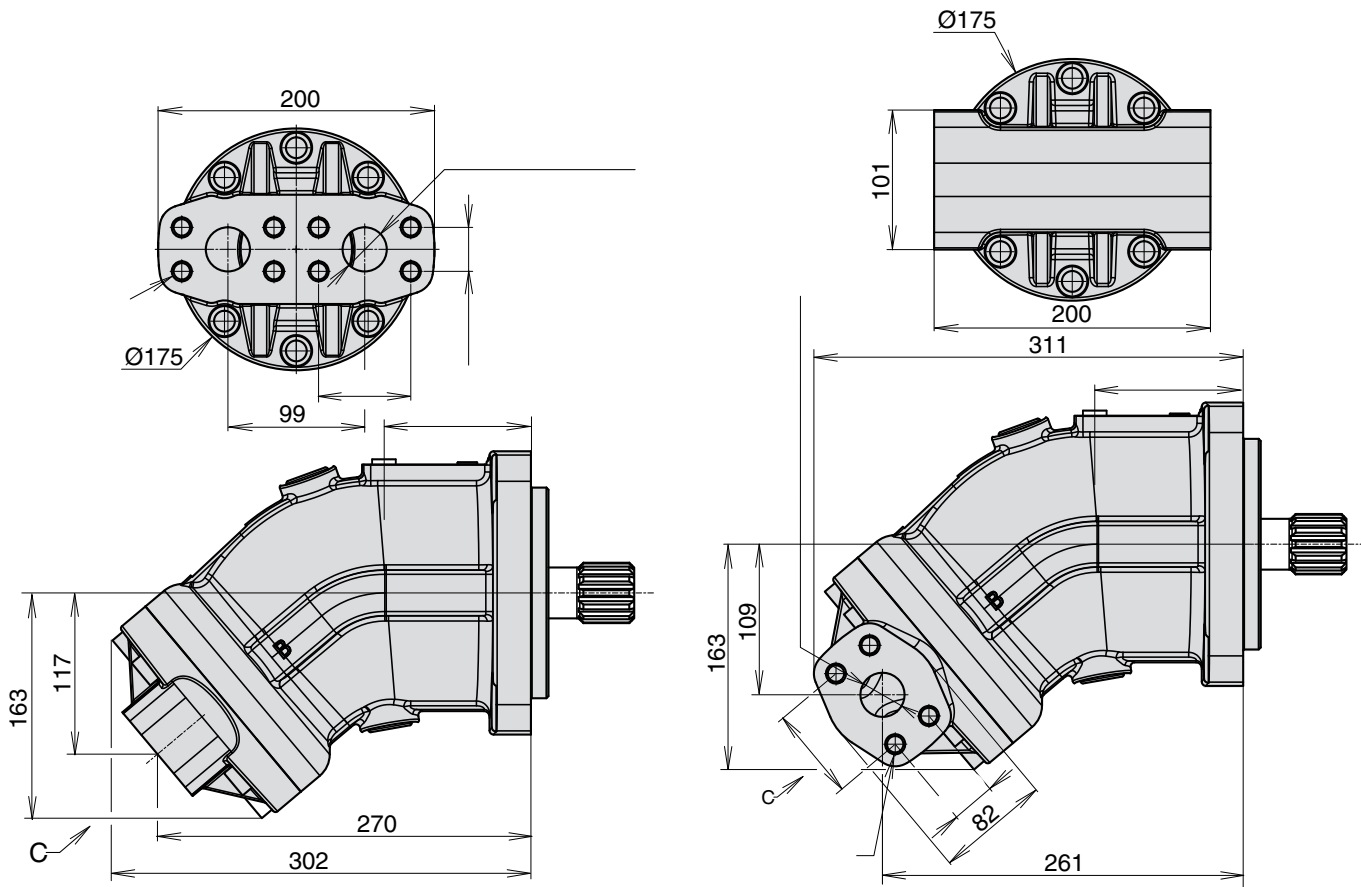
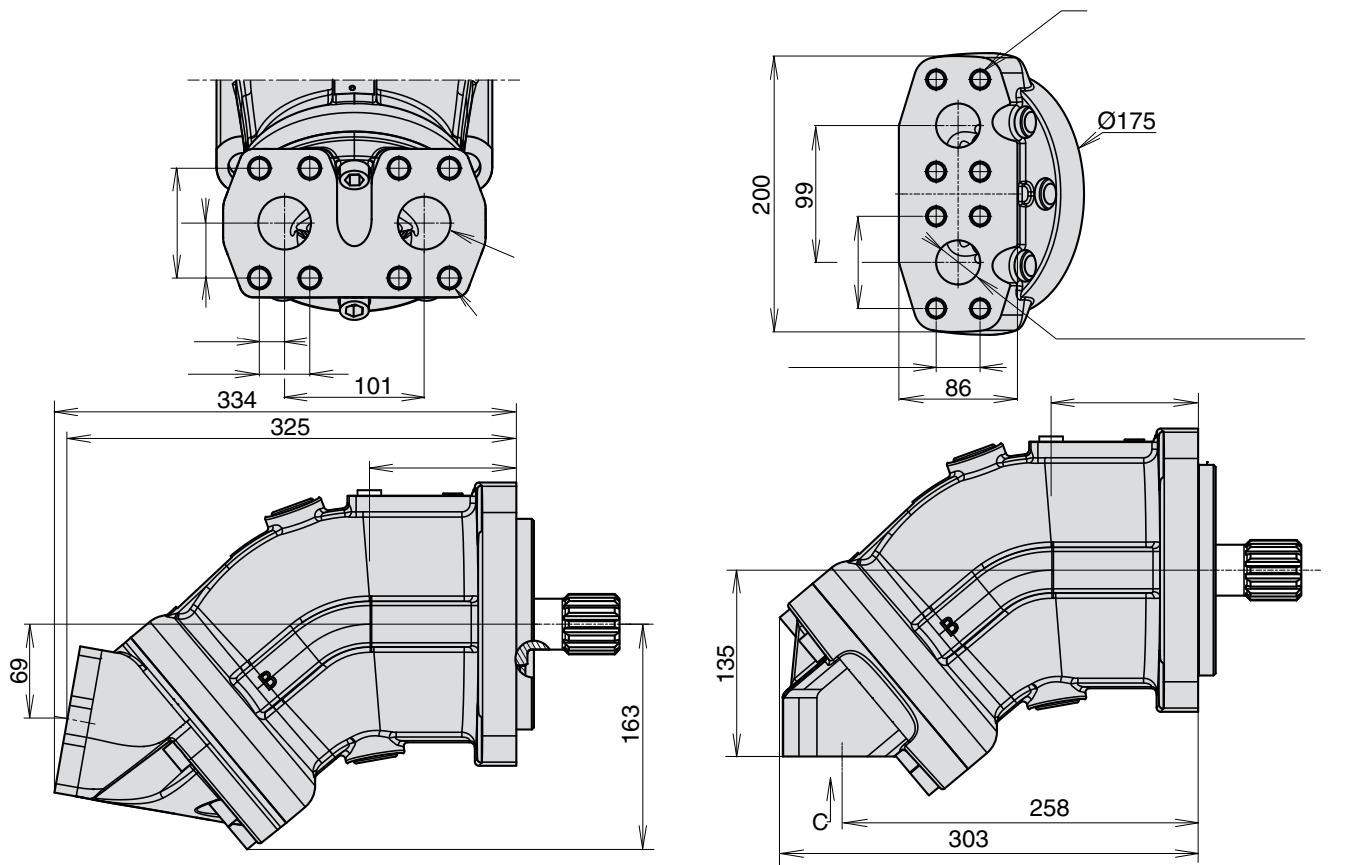

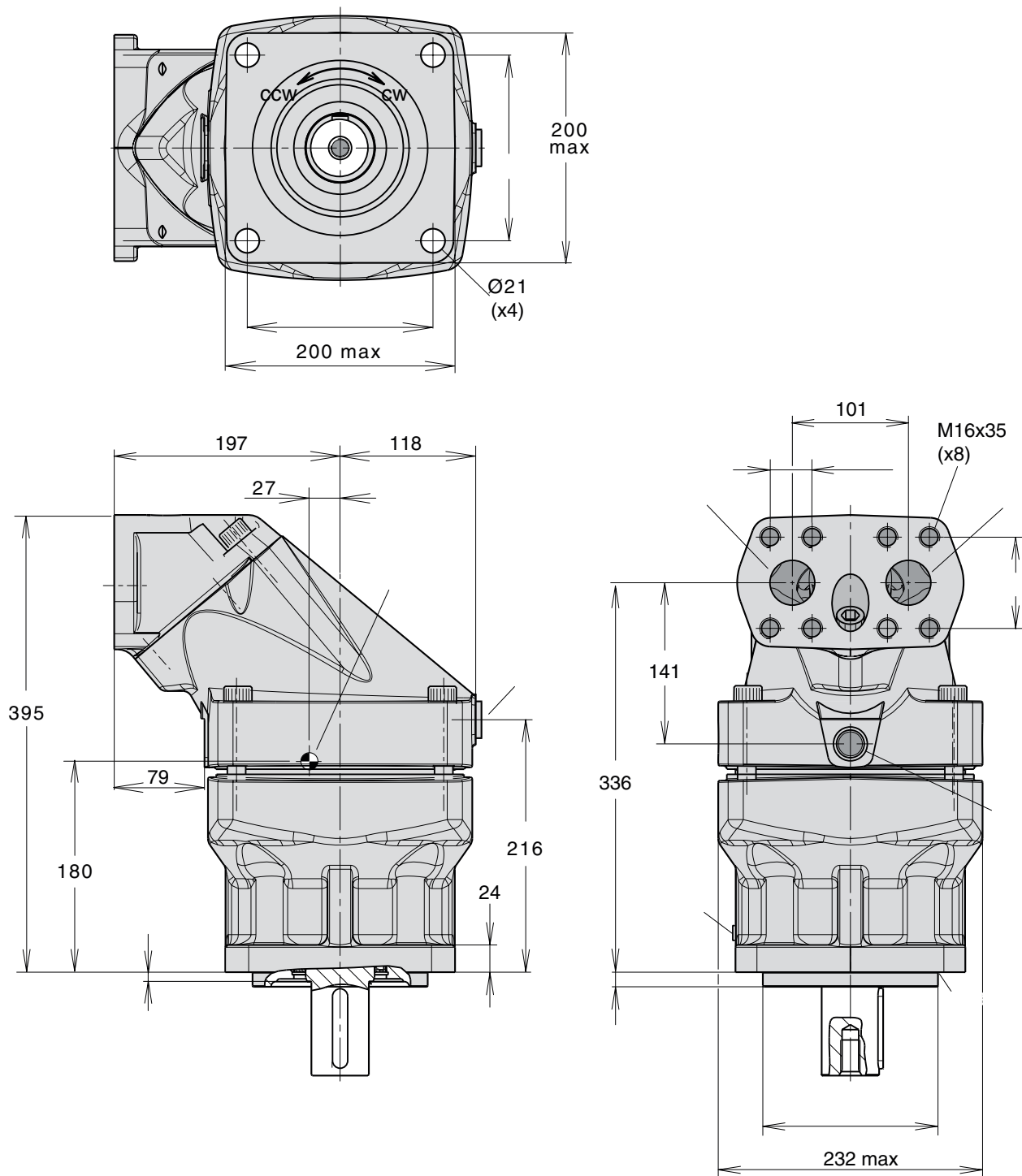

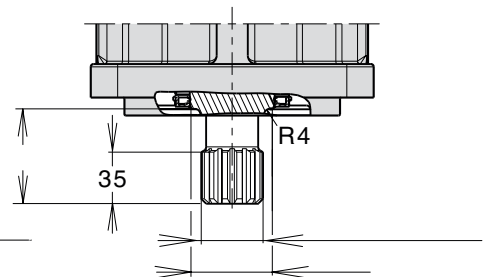
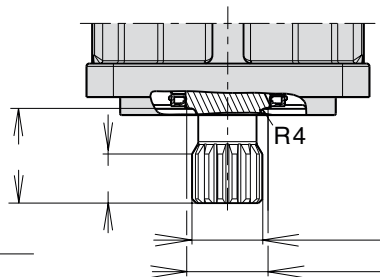
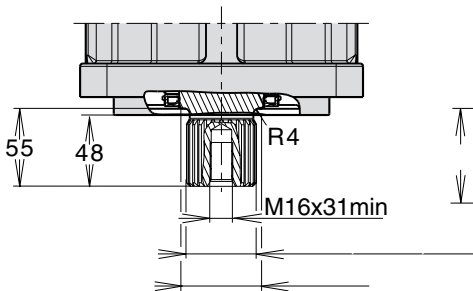
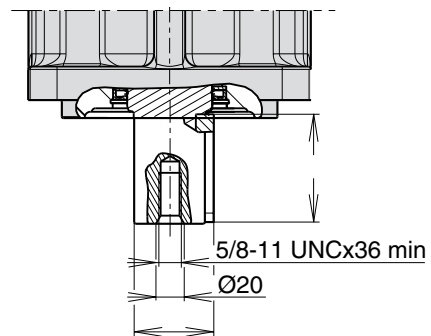
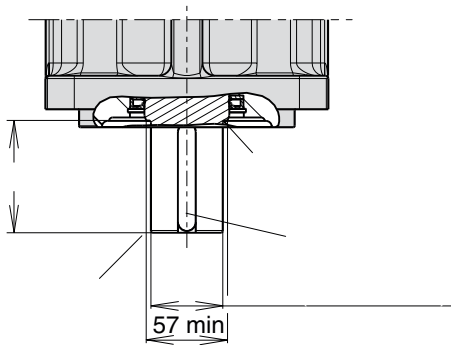
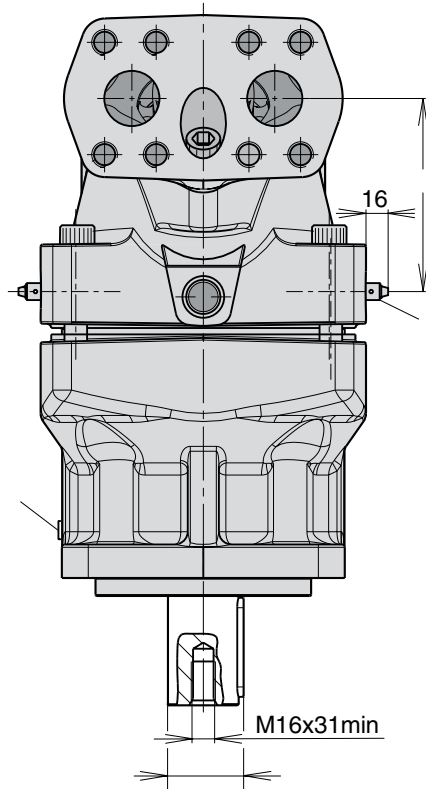
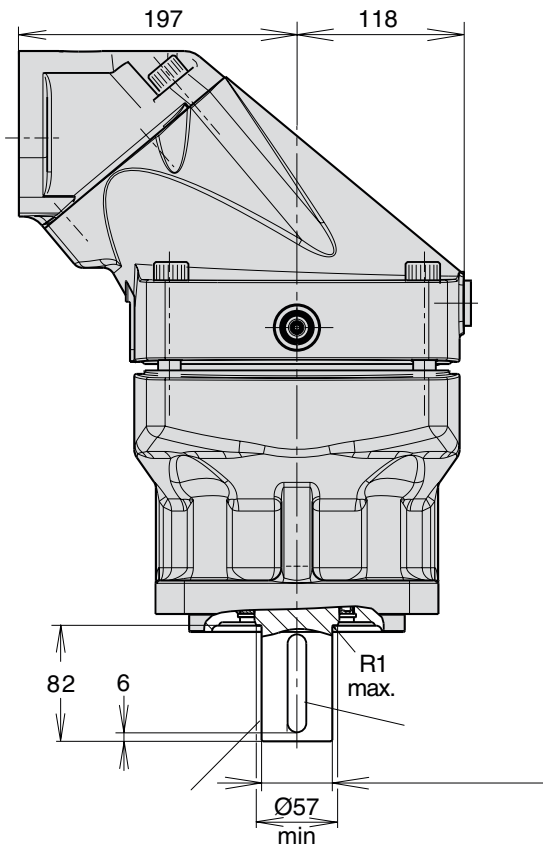

F12-30, -40, and -60
 (SAE versions with 2 bolt flange)

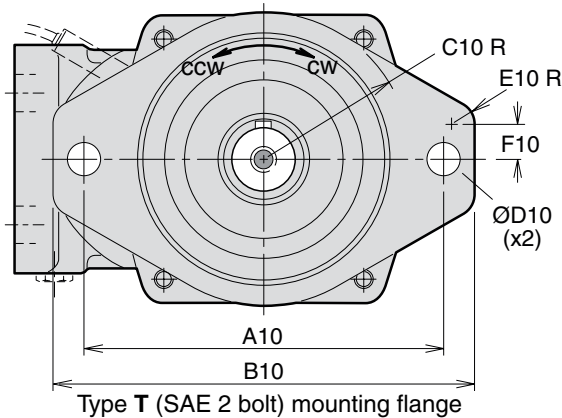

Shown: F12-60 with 2 bolt flange

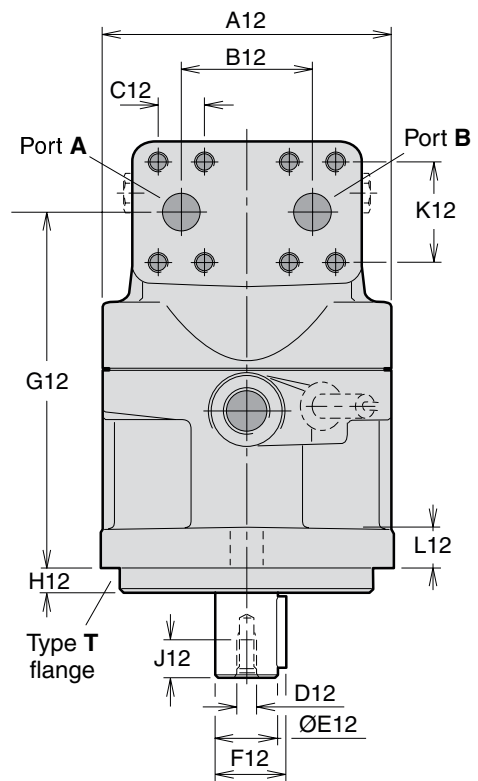
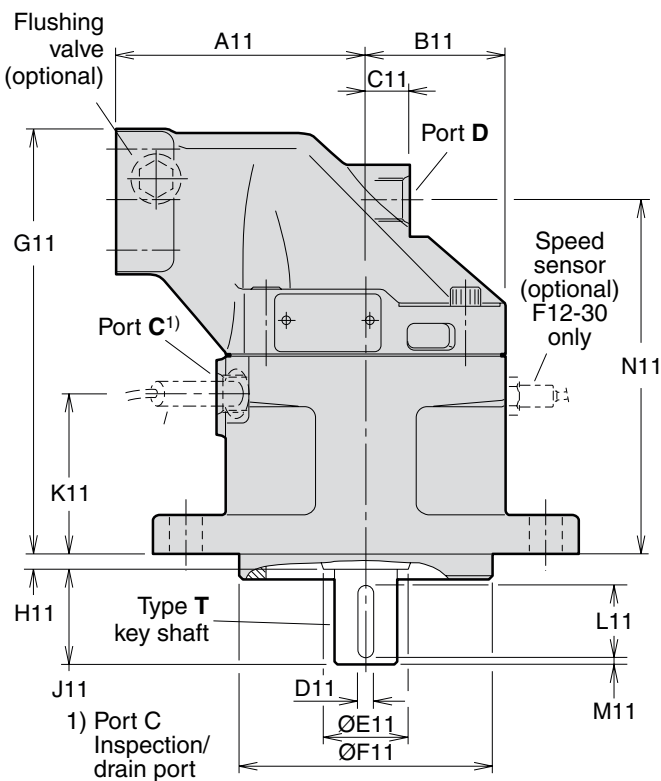

Shaft option S

Shaft option V (F12-30)

Shaft option V (F12-40)

Shaft option V (F12-60)

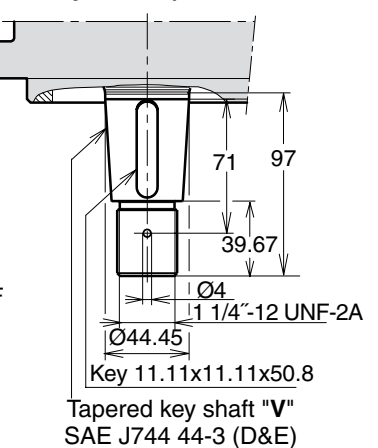
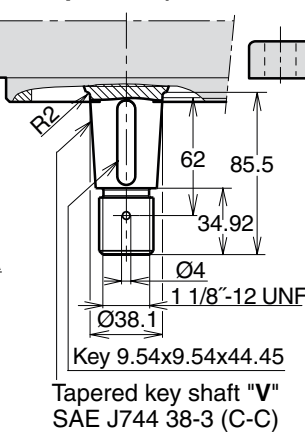
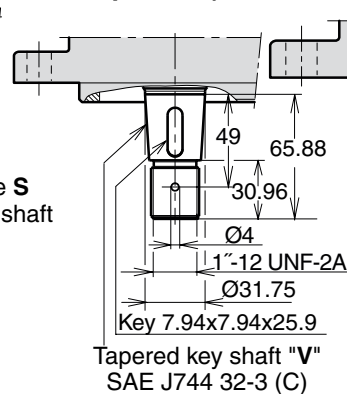
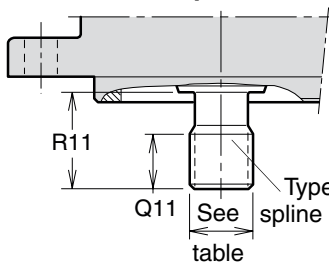

Dim.	F12-30	F12-40	F12-60
A10	146	181	181
B10	176	215	215
C10	63	74	74
D10	14.4	17.5	17.5
E10	10	16	16
F10	10	15.5	15.5
A11	100	110	125
B11	59	65	70
C11	25	26	22
D11	6.35	7.94	7.94
E11	33	42	42
F11	101.60/ 101.55	127.00/ 126.95	127.00/ 126.95
G11	189.5	197	214
H11	8	8	8
J11	38	48	48
K11	71	77	81.5
L11	31.8	38.1	38.1
M11	2.5	4	4
N11	154	161	178.5
Q11	26	27	27
R11	33	48	48
A12	122	134	144
B12	66	66	66
C12	23.8	23.8	23.8
D12 ¹⁾	⁵ / ₁₆ "-24	³ / ₈ "-24	³ / ₈ "-24
E12	25.40/ 25.35	31.75/ 31.70	31.75/ 31.70
F12	28.2	35.2	35.2
G12	154	161	178.5
H12	9.7	12.7	12.7
J12	16	19	19
K12	50.8	50.8	50.8
L12	18	20	20

1) UNF-2B thread

6) Max operating pressure 350 bar

Ports	F12-30	F12-40	F12-60
A, B size	19 (³ / ₄ "	19 (³ / ₄ "	19 (³ / ₄ "
Screw thread *)	³ / ₈ "-16 x22	³ / ₈ "-16 x20	³ / ₈ "-16 x22
C thread	³ / ₄ "-16	³ / ₄ "-16	⁷ / ₈ "-14
D thread	³ / ₄ "-16	³ / ₄ "-16	⁷ / ₈ "-14

A, B (main ports): SAE J518c (6000 psi)

C, D (drain ports): O-ring boss (SAE J514)

*) UN thread

Main ports A and B, type U (optional)	
F12-30	1 ¹ / ₁₆ " - 12 UN ⁶⁾
-40	1 ⁵ / ₁₆ " - 12 UN ⁶⁾
-60	1 ⁵ / ₁₆ " - 12 UN ⁶⁾

O-ring ports according to SAE J514d

Mounting flange T (SAE J744)	
F12-30	SAE 'B', 2 bolt
-40	SAE 'C', 2 bolt
-60	SAE 'C', 2 bolt

Spline shaft S (SAE J498b, class 1, flat root, side fit)	
F12-30	SAE 'B' 13 T; 16/32 DP
-40	SAE 'C' 14 T; 12/24 DP
-60	SAE 'C' 14 T; 12/24 DP

Key shaft (SAE J744)

	T (Standard)	V (optional)
F12-30	SAE 'B-B' Ø25.4 mm/1"	32-3
-40	SAE 'C' Ø31.75 mm/1 ¹ / ₄ "	38-3
-60	SAE 'C' Ø31.75 mm/1 ¹ / ₄ "	44-3

Accessories

Content	Page
Flushing valves for F12 motors.....	61
FV13 flushing valve block.....	62
Integrated pressure relief valve.....	63
Possible pressure settings.....	63
SR pressure relief anti-cavitation valve.....	64
SV pressure relief valve.....	65
SV pressure relief valve, Dimensions.....	66
Speed sensor.....	67
BLA Boost Units.....	68

Integrated flushing valve (F12-30, -40, -60, -80, -90)

General information

The integrated flushing valve supplies the motor with a cooling flow through the case which may be required when operating at high speeds and power levels.

In a closed loop hydrostatic transmission the flushing valve secures that cool fluid from the charge circuit is constantly added to the main circuit.

The flushing valve consists of a 'three-position', three-way spool valve which connects the low pressure side of the main hydraulic circuit with the motor case. The valve opens at a pressure differential between port A and port B of approximately 14 bar.

In order to limit the flow, a nozzle with a orifice is available from Parker Hannifin. The diagram to the right shows flow versus differential pressure.

For general advise when flushing might be needed, see page 67.

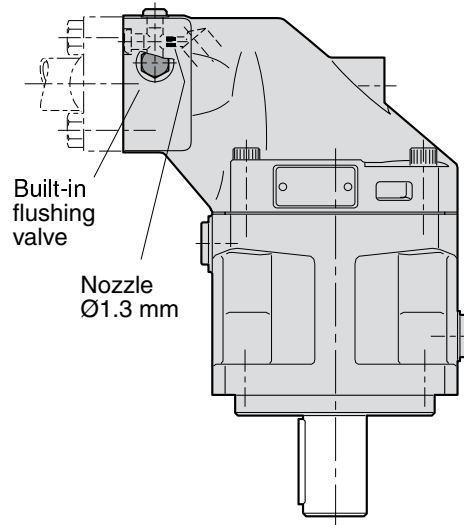

4

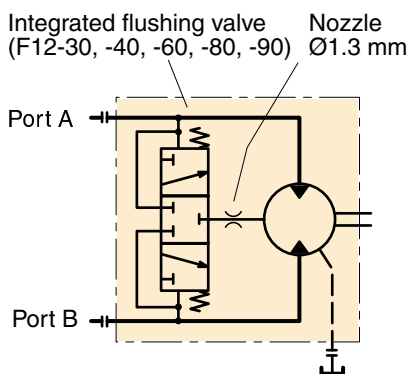

Hydraulic schematic.

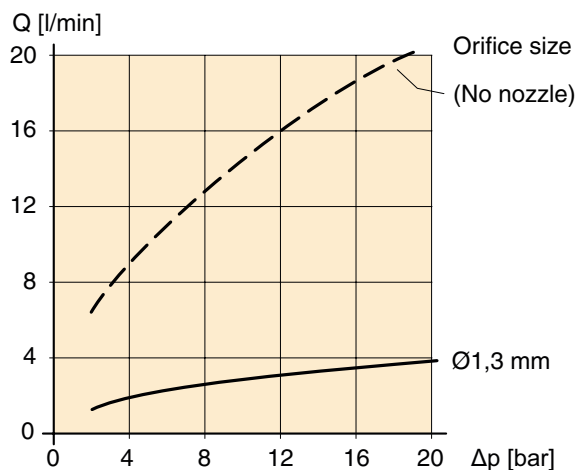

Flow versus pressure differential (port A or B to tank).

Ordering code

F12 - **080** - **MF** - **IV** - **K** - **000** - **L130** - **P0**

Standard F12 ordering code
 (for F12-30, -40, -60, -80, -90)

Code	Nozzle designation
L 130	1.3 mm

NOTE: FV13 flushing valve block for F12-110 shown on next page.

FV13 flushing valve block (for F12-110, -125)

The FV13 for the F12-110 / -125 motor has the same function as the integrated flushing valve for the other F12 frame sizes. The valve block mounts between the motor port flange and the split-flange tube/hose connectors utilizing 'long' mounting screws (screw size M14x75 or 1/2"-13 UNC based on split-flange height as shown below).

The FV13 flushing valve kit contains the required O-rings (shown below) but no screws, split-flanges or tube/hose connectors.

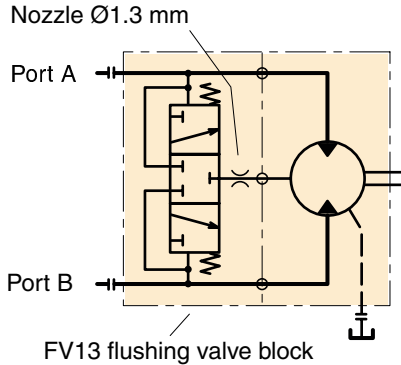

Hydraulic schematic.

FV13 installation

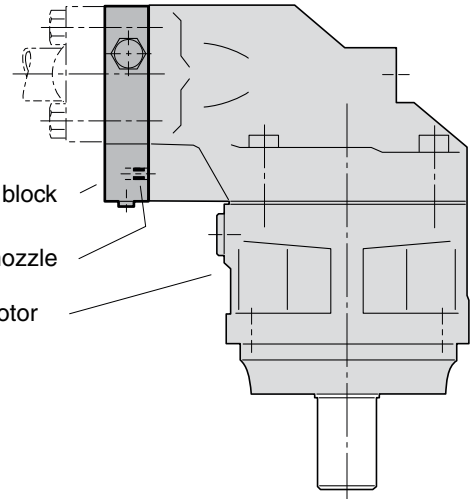
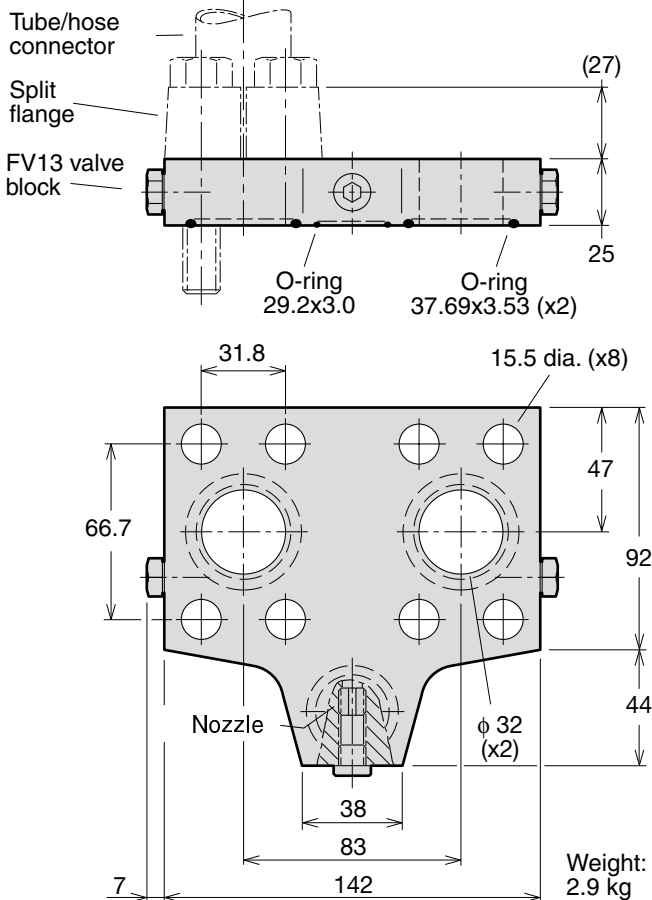

FV13 Ordering code

FV	1	3	-	H	-	A	-	L130
Valve type	Version	Size	Seals	Techn. status	Nozzel			
Flushing valve	1	3	H	A	Code Nozzel L130 Ø1.3 mm			
Code Version		Code Seals		Code Techn. status				
1 Factory assigned		H Nitrile rubber		A Factory assigned				
Code Size (SAE 6000 psi)		Code Seals						
3 1 1/4" (for F12-110 / -125)		H Nitrile rubber						

FV13 restrictor nozzles

When required, a nozzle is utilized to restrict the flow through the F12-110, -125 motor case. The nozzle installs in the drilled and tapped (M10x1.0) drain line located in the valve block as shown to the left. The diagram on page 61 shows flushing flow versus differential pressure for selected orifice sizes.

The following table lists currently available nozzles and the corresponding FV13 ordering code designation.

Designation	Flushing valve Part number	Orifice size [mm]	Orifice Part number
L000 no nozzle	3780292		
L130 (std.)	3795623	1.3	379 4413

**Integrated pressure relief valve
 (F12-030, -040, -060)**

Integrated pressure relief valves are available for F12-030, F12-040 and F12-060. These are designed to protect the motor from short duration pressure spikes. The motor could be ordered with non-adjustable pressure setting between 210 - 420 bar. The motor has to be ordered as unidirectional, L or R, and this is specified in the ordering code as example below.

F12-030-MS-SV-S-000-P28L-P0
 P=Pressure relief valve, 28 = 280 bar, L = left

Possible pressure settings

Code	Pressure bar
21	210
23	230
25	250
28	280
30	300
33	330
35	350
38	380
40	400
42	420

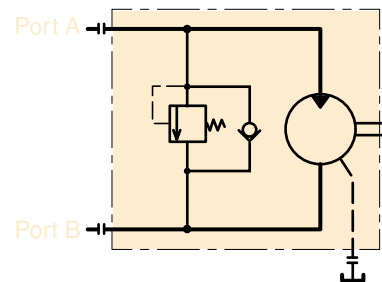

Diagram for PLC082 pressure relief valves integrated in F12-030

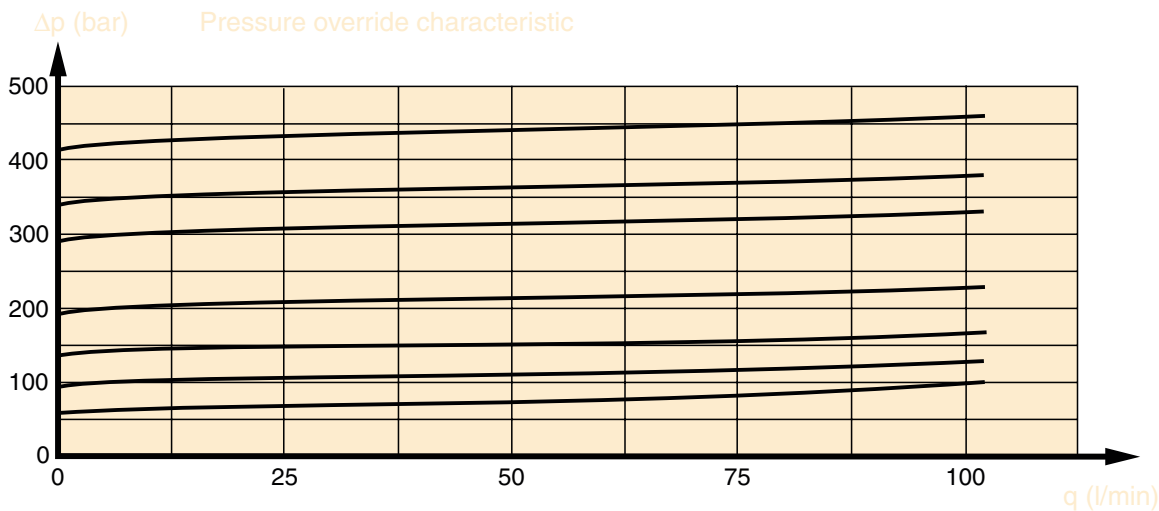
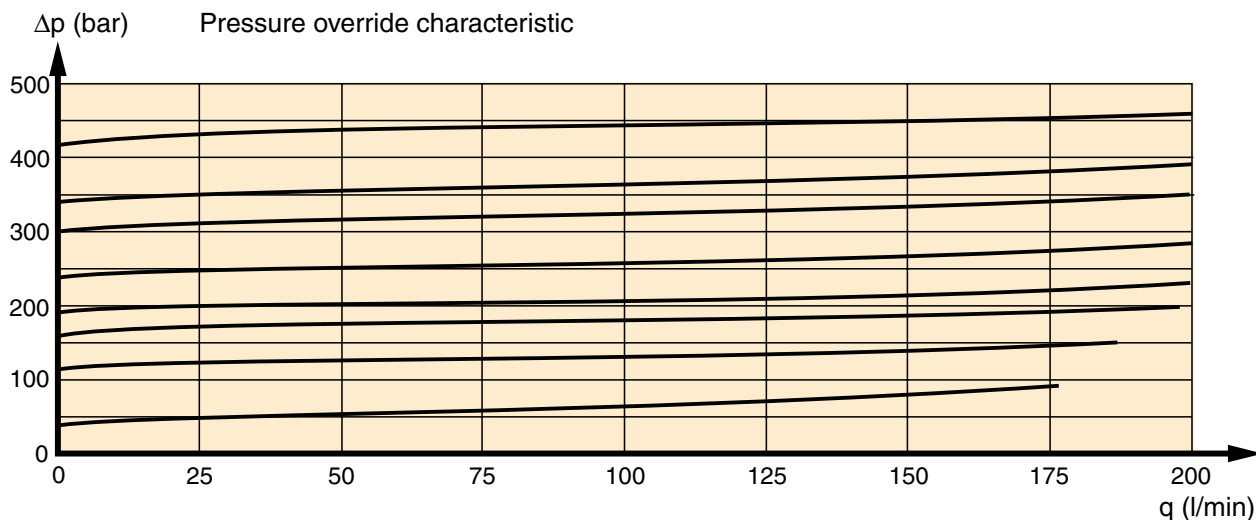

Diagram for PLC182 pressure relief valves integrated in F12-040 and F12-060



Pressure relief/anticav. valve for F12-motors Series F11/F12

SR pressure relief anti-cavitation valve

The SR pressure relief/make-up valve block for series F12 motors is designed to protect the motor and the main hydraulic lines from short duration pressure spikes. The valve block also provides an excellent make-up function.

The valve block installs directly on the motor port flange, and is available in 3 sizes:

- 1 3/4" for F12-30/-40/-60
- 2 1" for F12-80, -90
- 3 1 1/4" for F12-110, -125

The SR valve block consists of a housing containing two high pressure relief cartridges and two separate check valves for anti-cavitation. Cartridges are available in non-adjustable pressure settings between 280 and 420 bar (4000 and 6000 psi respectively).

A make-up port (G) is also provided. In certain operating conditions, the motor (when operating as a pump) may cavitate because of insufficient inlet pressure.

To prevent this, the G port should be pressurized. Contact Parker Hannifin for further information.

The pressure drop through the main ports (A-A' or B-B') is low. As an example, the pressure drop on size 1 (3/4") is 0.45 bar (6.5 psi) at 175 l/min, and on size 2 (1") 0.7 bar (10 psi) at 250 l/min.

NOTE: The valve block includes main port O-rings (facing the motor) but no mounting screws.

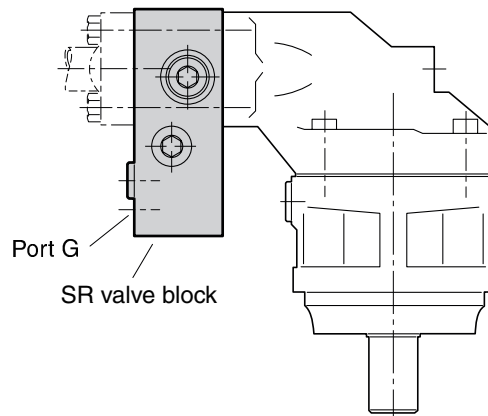

SR valve block location.

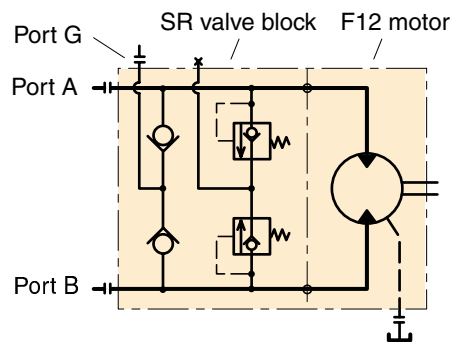

SR valve block schematic.

Ordering code

SR	1		-		/		-	00	-	H	F	-	A																																																																																																																																																																																																																																																																																																																																																																												
Valve function	Version	Port size		Pressure settings				Serial number		Seals	Threads		Techn. status																																																																																																																																																																																																																																																																																																																																																																												
<table border="1" style="width: 100%; border-collapse: collapse;"> <tr> <td style="background-color: #f0f0f0;">Code</td> <td style="background-color: #f0f0f0;">Valve function</td> <td colspan="12"></td> </tr> <tr> <td>SR</td> <td>Pressure relief/make-up valve block</td> <td colspan="12"></td> </tr> <tr> <td colspan="14"> </td> </tr> <tr> <td colspan="14"> <table border="1" style="width: 100%; border-collapse: collapse;"> <tr> <td style="background-color: #f0f0f0;">Code</td> <td style="background-color: #f0f0f0;">Version</td> <td colspan="12"></td> </tr> <tr> <td>1</td> <td>Factory assigned</td> <td colspan="12"></td> </tr> </table> </td> </tr> <tr> <td colspan="14"> <table border="1" style="width: 100%; border-collapse: collapse;"> <tr> <td style="background-color: #f0f0f0;">Code</td> <td style="background-color: #f0f0f0;">Port size (SAE 6000 psi)</td> <td colspan="12"></td> </tr> <tr> <td>1</td> <td>3/4" for: F12-30, -40, -60</td> <td colspan="12"></td> </tr> <tr> <td>2</td> <td>1" for: F12-80, -90</td> <td colspan="12"></td> </tr> <tr> <td>3</td> <td>1 1/4" for: F12-110, -125</td> <td colspan="12"></td> </tr> </table> </td> </tr> <tr> <td colspan="14"> <table border="1" style="width: 100%; border-collapse: collapse;"> <tr> <td style="background-color: #f0f0f0;">Code</td> <td style="background-color: #f0f0f0;">Pressure settings (A/B ports) [bar]</td> <td colspan="12"></td> </tr> <tr> <td>280, 300, 330, 350, 380, 400 or 420</td> <td></td> <td colspan="12"></td> </tr> </table> </td> </tr> <tr> <td colspan="14"> <table border="1" style="width: 100%; border-collapse: collapse;"> <tr> <td style="background-color: #f0f0f0;">Code</td> <td style="background-color: #f0f0f0;">Serial number</td> <td colspan="12"></td> </tr> <tr> <td>00</td> <td>Factory assigned</td> <td colspan="12"></td> </tr> </table> </td> </tr> <tr> <td colspan="14"> <table border="1" style="width: 100%; border-collapse: collapse;"> <tr> <td style="background-color: #f0f0f0;">Code</td> <td style="background-color: #f0f0f0;">Seals</td> <td colspan="12"></td> </tr> <tr> <td>H</td> <td>Nitrile rubber</td> <td colspan="12"></td> </tr> </table> </td> </tr> <tr> <td colspan="14"> <table border="1" style="width: 100%; border-collapse: collapse;"> <tr> <td style="background-color: #f0f0f0;">Code</td> <td style="background-color: #f0f0f0;">Threads (port G)</td> <td colspan="12"></td> </tr> <tr> <td>F</td> <td>Metric</td> <td colspan="12"></td> </tr> </table> </td> </tr> <tr> <td colspan="14"> <table border="1" style="width: 100%; border-collapse: collapse;"> <tr> <td style="background-color: #f0f0f0;">Code</td> <td style="background-color: #f0f0f0;">Techn. status</td> <td colspan="12"></td> </tr> <tr> <td>A</td> <td>Factory assigned</td> <td colspan="12"></td> </tr> </table> </td> </tr> </table>														Code	Valve function													SR	Pressure relief/make-up valve block																											<table border="1" style="width: 100%; border-collapse: collapse;"> <tr> <td style="background-color: #f0f0f0;">Code</td> <td style="background-color: #f0f0f0;">Version</td> <td colspan="12"></td> </tr> <tr> <td>1</td> <td>Factory assigned</td> <td colspan="12"></td> </tr> </table>														Code	Version													1	Factory assigned													<table border="1" style="width: 100%; border-collapse: collapse;"> <tr> <td style="background-color: #f0f0f0;">Code</td> <td style="background-color: #f0f0f0;">Port size (SAE 6000 psi)</td> <td colspan="12"></td> </tr> <tr> <td>1</td> <td>3/4" for: F12-30, -40, -60</td> <td colspan="12"></td> </tr> <tr> <td>2</td> <td>1" for: F12-80, -90</td> <td colspan="12"></td> </tr> <tr> <td>3</td> <td>1 1/4" for: F12-110, -125</td> <td colspan="12"></td> </tr> </table>														Code	Port size (SAE 6000 psi)													1	3/4" for: F12-30, -40, -60													2	1" for: F12-80, -90													3	1 1/4" for: F12-110, -125													<table border="1" style="width: 100%; border-collapse: collapse;"> <tr> <td style="background-color: #f0f0f0;">Code</td> <td style="background-color: #f0f0f0;">Pressure settings (A/B ports) [bar]</td> <td colspan="12"></td> </tr> <tr> <td>280, 300, 330, 350, 380, 400 or 420</td> <td></td> <td colspan="12"></td> </tr> </table>														Code	Pressure settings (A/B ports) [bar]													280, 300, 330, 350, 380, 400 or 420														<table border="1" style="width: 100%; border-collapse: collapse;"> <tr> <td style="background-color: #f0f0f0;">Code</td> <td style="background-color: #f0f0f0;">Serial number</td> <td colspan="12"></td> </tr> <tr> <td>00</td> <td>Factory assigned</td> <td colspan="12"></td> </tr> </table>														Code	Serial number													00	Factory assigned													<table border="1" style="width: 100%; border-collapse: collapse;"> <tr> <td style="background-color: #f0f0f0;">Code</td> <td style="background-color: #f0f0f0;">Seals</td> <td colspan="12"></td> </tr> <tr> <td>H</td> <td>Nitrile rubber</td> <td colspan="12"></td> </tr> </table>														Code	Seals													H	Nitrile rubber													<table border="1" style="width: 100%; border-collapse: collapse;"> <tr> <td style="background-color: #f0f0f0;">Code</td> <td style="background-color: #f0f0f0;">Threads (port G)</td> <td colspan="12"></td> </tr> <tr> <td>F</td> <td>Metric</td> <td colspan="12"></td> </tr> </table>														Code	Threads (port G)													F	Metric													<table border="1" style="width: 100%; border-collapse: collapse;"> <tr> <td style="background-color: #f0f0f0;">Code</td> <td style="background-color: #f0f0f0;">Techn. status</td> <td colspan="12"></td> </tr> <tr> <td>A</td> <td>Factory assigned</td> <td colspan="12"></td> </tr> </table>														Code	Techn. status													A	Factory assigned												
Code	Valve function																																																																																																																																																																																																																																																																																																																																																																																								
SR	Pressure relief/make-up valve block																																																																																																																																																																																																																																																																																																																																																																																								
<table border="1" style="width: 100%; border-collapse: collapse;"> <tr> <td style="background-color: #f0f0f0;">Code</td> <td style="background-color: #f0f0f0;">Version</td> <td colspan="12"></td> </tr> <tr> <td>1</td> <td>Factory assigned</td> <td colspan="12"></td> </tr> </table>														Code	Version													1	Factory assigned																																																																																																																																																																																																																																																																																																																																																												
Code	Version																																																																																																																																																																																																																																																																																																																																																																																								
1	Factory assigned																																																																																																																																																																																																																																																																																																																																																																																								
<table border="1" style="width: 100%; border-collapse: collapse;"> <tr> <td style="background-color: #f0f0f0;">Code</td> <td style="background-color: #f0f0f0;">Port size (SAE 6000 psi)</td> <td colspan="12"></td> </tr> <tr> <td>1</td> <td>3/4" for: F12-30, -40, -60</td> <td colspan="12"></td> </tr> <tr> <td>2</td> <td>1" for: F12-80, -90</td> <td colspan="12"></td> </tr> <tr> <td>3</td> <td>1 1/4" for: F12-110, -125</td> <td colspan="12"></td> </tr> </table>														Code	Port size (SAE 6000 psi)													1	3/4" for: F12-30, -40, -60													2	1" for: F12-80, -90													3	1 1/4" for: F12-110, -125																																																																																																																																																																																																																																																																																																																																
Code	Port size (SAE 6000 psi)																																																																																																																																																																																																																																																																																																																																																																																								
1	3/4" for: F12-30, -40, -60																																																																																																																																																																																																																																																																																																																																																																																								
2	1" for: F12-80, -90																																																																																																																																																																																																																																																																																																																																																																																								
3	1 1/4" for: F12-110, -125																																																																																																																																																																																																																																																																																																																																																																																								
<table border="1" style="width: 100%; border-collapse: collapse;"> <tr> <td style="background-color: #f0f0f0;">Code</td> <td style="background-color: #f0f0f0;">Pressure settings (A/B ports) [bar]</td> <td colspan="12"></td> </tr> <tr> <td>280, 300, 330, 350, 380, 400 or 420</td> <td></td> <td colspan="12"></td> </tr> </table>														Code	Pressure settings (A/B ports) [bar]													280, 300, 330, 350, 380, 400 or 420																																																																																																																																																																																																																																																																																																																																																													
Code	Pressure settings (A/B ports) [bar]																																																																																																																																																																																																																																																																																																																																																																																								
280, 300, 330, 350, 380, 400 or 420																																																																																																																																																																																																																																																																																																																																																																																									
<table border="1" style="width: 100%; border-collapse: collapse;"> <tr> <td style="background-color: #f0f0f0;">Code</td> <td style="background-color: #f0f0f0;">Serial number</td> <td colspan="12"></td> </tr> <tr> <td>00</td> <td>Factory assigned</td> <td colspan="12"></td> </tr> </table>														Code	Serial number													00	Factory assigned																																																																																																																																																																																																																																																																																																																																																												
Code	Serial number																																																																																																																																																																																																																																																																																																																																																																																								
00	Factory assigned																																																																																																																																																																																																																																																																																																																																																																																								
<table border="1" style="width: 100%; border-collapse: collapse;"> <tr> <td style="background-color: #f0f0f0;">Code</td> <td style="background-color: #f0f0f0;">Seals</td> <td colspan="12"></td> </tr> <tr> <td>H</td> <td>Nitrile rubber</td> <td colspan="12"></td> </tr> </table>														Code	Seals													H	Nitrile rubber																																																																																																																																																																																																																																																																																																																																																												
Code	Seals																																																																																																																																																																																																																																																																																																																																																																																								
H	Nitrile rubber																																																																																																																																																																																																																																																																																																																																																																																								
<table border="1" style="width: 100%; border-collapse: collapse;"> <tr> <td style="background-color: #f0f0f0;">Code</td> <td style="background-color: #f0f0f0;">Threads (port G)</td> <td colspan="12"></td> </tr> <tr> <td>F</td> <td>Metric</td> <td colspan="12"></td> </tr> </table>														Code	Threads (port G)													F	Metric																																																																																																																																																																																																																																																																																																																																																												
Code	Threads (port G)																																																																																																																																																																																																																																																																																																																																																																																								
F	Metric																																																																																																																																																																																																																																																																																																																																																																																								
<table border="1" style="width: 100%; border-collapse: collapse;"> <tr> <td style="background-color: #f0f0f0;">Code</td> <td style="background-color: #f0f0f0;">Techn. status</td> <td colspan="12"></td> </tr> <tr> <td>A</td> <td>Factory assigned</td> <td colspan="12"></td> </tr> </table>														Code	Techn. status													A	Factory assigned																																																																																																																																																																																																																																																																																																																																																												
Code	Techn. status																																																																																																																																																																																																																																																																																																																																																																																								
A	Factory assigned																																																																																																																																																																																																																																																																																																																																																																																								

SR pressure relief anti-cavitation valve, Dimensions

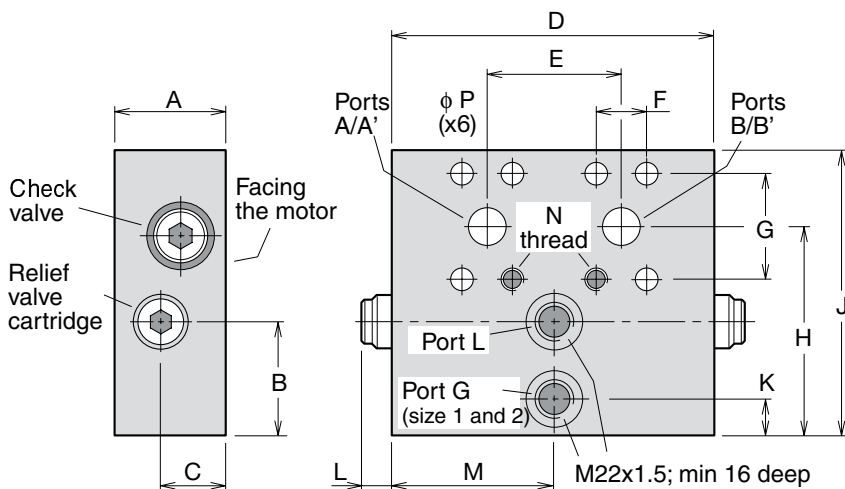

Dim. [mm]	Size 1 (3/4")	Size 2 (1")	Size 3 (1 1/4")
A	55	57	57
B	55	55	25
C	32	32	26
D	157	160	160
E	66	75	83
F	23.8	27.8	31.8
G	50.8	57.15	66.7
H	103	109	88
J	140	150	135
K	18	18	-
L	18	18	18
M	78.5	80	-
N	M10 x18	M12 x20	M14 x23
P	11	13	15.5

Weight [kg]	Size 1 (3/4")	Size 2 (1")	Size 3 (1 1/4")
	7.4	9.1	8.5



SV pressure relief valve

General information

The SV pressure relief valve block for series F12 motors is designed to protect the motor and adjacent hydraulic components from short duration pressure peaks.

It installs directly on the motor port flange and is available in two sizes:

- '1': 3/4" for F12-30/-40/-60
- '2': 1" for F12-80/-90

The valve block consists of a housing containing two high pressure relief cartridges with anti-cavitation function. Cartridges are available in non-adjustable pressure settings between 280 and 420 bar.

A make-up/drain port, L, is also provided. In certain operating conditions the motor may cavitate because of in-sufficient inlet pressure. To prevent this, the L port can be pressurized. When there is a risk of over-heating, the L port can also be utilized to take out part of the flow for cooling. Contact Parker Hannifin for further information.

The pressure drop through the main ports (A-A' or B-B') is low. As an example, the pressure drop on size 1 (3/4") is 0.45 bar (6.5 psi) at 175 l/min (45 gpm), and on size 2 (1") 0.7 bar (10 psi) at 250 l/min (65 gpm).

- NOTE:**
- The valve block includes main port O-rings (facing the motor) but no mounting screws.
 - The valve blocks can be used on all versions of series F12 motors.

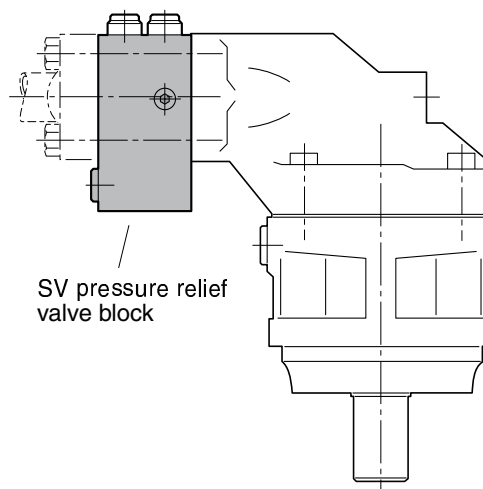

SV valve block installed on an F12 motor.

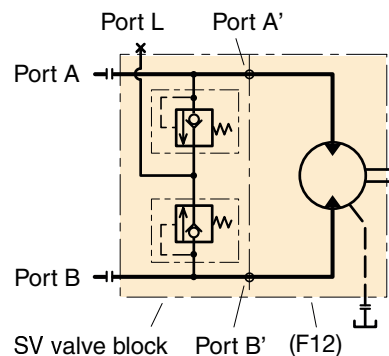

Hydraulic schematic.

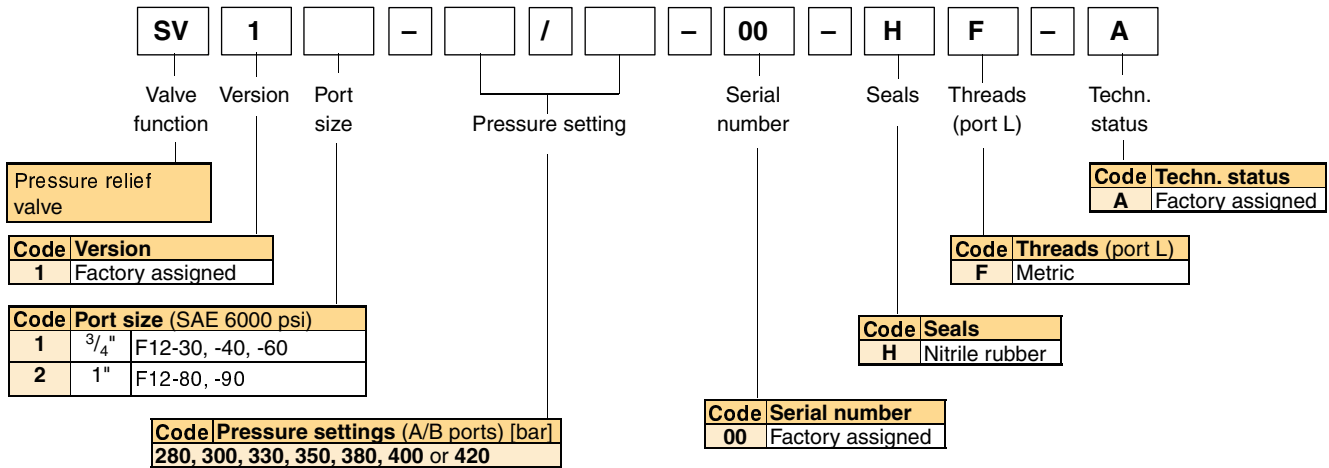

SV pressure relief valve, Dimensions

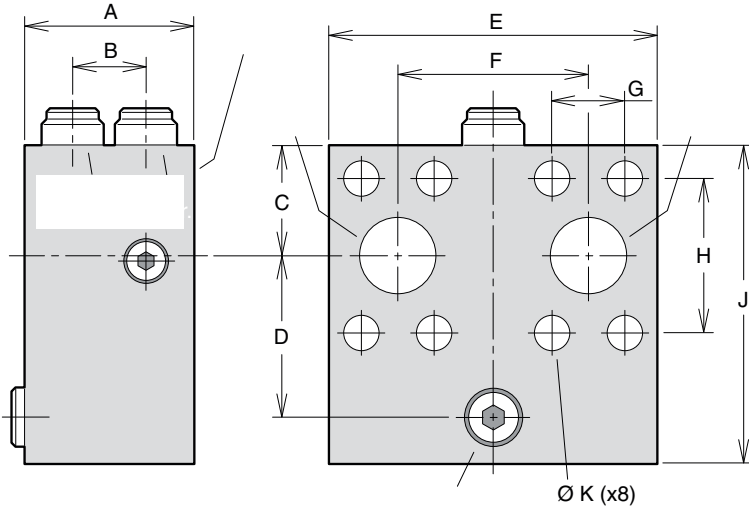

Dim. [mm]	SV11	SV12
A	71	73
B	31	31
C	36	41
D	47	51
E	130	127
F	66	75
G	23.8	27.8
H	50.8	57.2
J	99	109
K	11	13
Weight [kg]	4.2	5.0

MV Anti-cavitation valve / make up valve block

The make-up valve block for series F12 motors is designed to prevent cavitation inside motor by directing flow to inlet port from return side.

The manifold is uni-directional but can be installed in either motor direction

The valve block installs directly on the motor port flange, and is available in 2 sizes:

The valve block consists of one check valve for make-up function.

The make-up valve opens at a pressure of approx. 0,2 bar.

NOTE: The valve block includes main port O-rings (facing the motor) but no mounting screws.

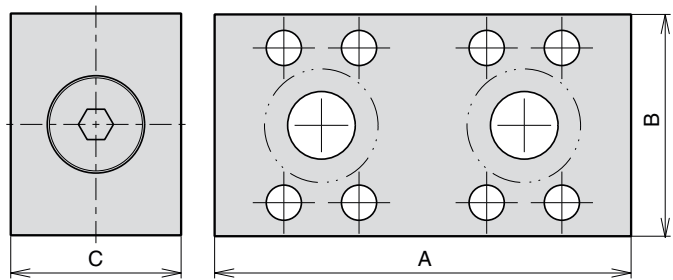

Size	For Motor	A	B	C	Order number
1"	F12-80, -90	154	82	63	3720140
1½"	F12-152, -162, -182, -250	208.5	105	47	3784195

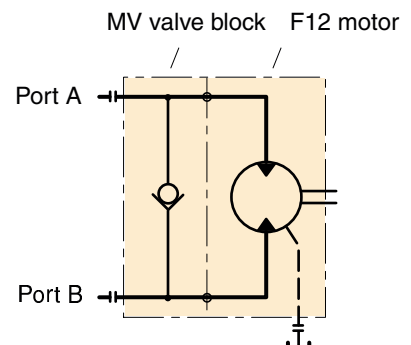

A wide range of speed sensor kits are available for series F11/F12.

The sensors are ferrostat differential (Hall-effect)
On F12 the speed sensor is directed towards the ring gear. On F11 the speed sensor is directed towards the pistons. The sensor output is a square wave signal within a frequency range of 0 Hz to 15 kHz.

- NOTE: - All F12 are prepared for speed sensor as standard, but F11 series must be specified in the ordering code refer to pages 12-14 (F11)
- **On F11 the pistons position must be known before mounting.**
 - The speed sensor is also shown in the illustrations on pages 17 to 37 and 46 to 59.

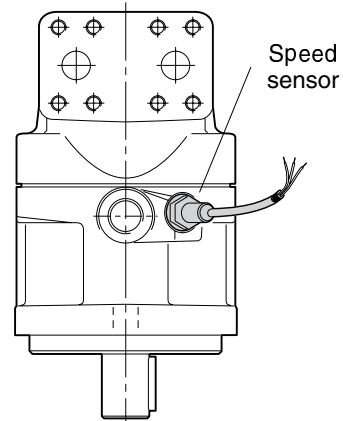

F12 with speed sensor.

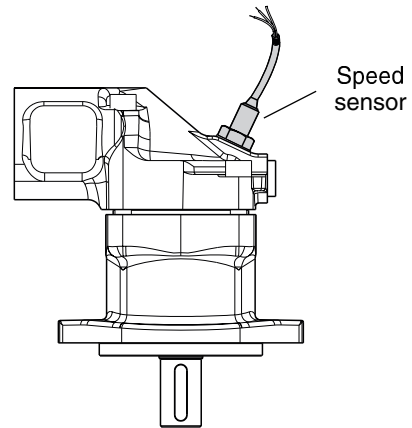

F11-14 with speed sensor.

BLA

General information

The BLA boost unit simplifies the building of closed or semi-closed hydrostatic transmissions.

Main features are:

- Replaces conventional charge pump and corresponding valves in many applications
- Allows pump speeds above normal selfpriming speed
- Suitable for system flow rates to 400 l/min
- Includes filter
- Simple construction - no moving/wear parts
- Cost-effective installation
- Small tank size
- Helps in building a low-cost hydrostatic transmission.

Description

In a closed circuit hydrostatic transmission, a charge pump is normally included with the main pump, providing make-up fluid which replaces pump and motor volumetric losses. It also maintains sufficient pump inlet pressure to avoid cavitation.

The BLA boost unit replaces the charge pump in many applications, when the following conditions are met:

- The max-to-min pump flow ratio does not exceed 2:1
- System pressure changes gradually without frequent and pronounced pressure peaks
- The line length between pump and boost unit is relatively short.

There are two basic sizes of the BLA boost unit:

- BLA 4 (to 160 l/min pump flow)
- BLA 6 (to 400 l/min pump flow).

The main part of the unit is an aluminium housing with a built-in nozzle and an injector; refer to the cross section to the right.

When fluid flows from the motor outlet port through the unit and to the pump inlet port, the increased fluid velocity between the nozzle and injector creates a low pressure zone causing additional fluid to be drawn from tank into the main circuit.

Also, pressure increases after the injector, allowing the pump to be operated at speeds higher than the self-priming speed. The 'boost pressure' increases with flow. The housing includes ports that should be connected to the pump and motor drain ports respectively.

An additional bleed-off nozzle diverts approx. 10% of the main flow through the cartridge filter before being directed to the tank.

Oil cooling

An oil cooler is usually required in the hydraulic system, in order to remove the heat that is generated in the main circuit. A full-flow oil cooler should be installed in the return line between the motor and the boost unit.

For more information please see our technical catalogue BLA boost unit MSG30-8224/UK

Typical applications:

- Fan drives
- Propeller drives
- Generator drives
- Pump drives

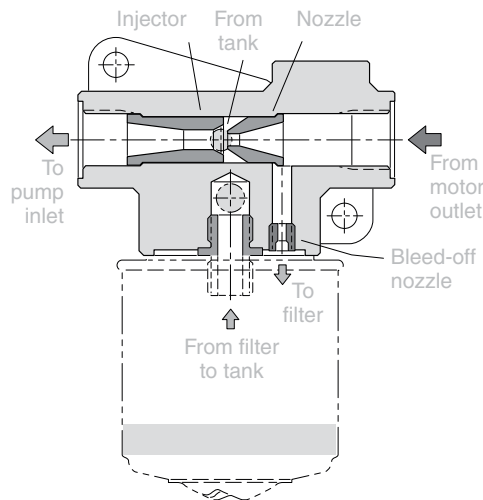

BLA boost unit cross section.

Boost unit installation

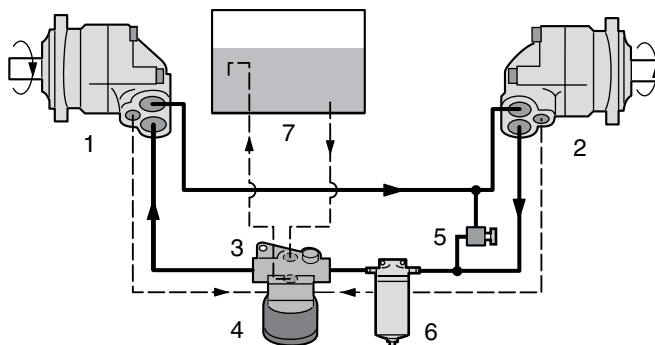

- | | |
|--|-------------------------------------|
| 1. Pump | 5. Pressure relief valve |
| 2. Motor | 6. Full-flow filter (when required) |
| 3. Boost unit (with injector and nozzle) | 7. Reservoir |
| 4. Filter cartridge | |

Direction of rotation

The motor versions are bi-directional.

The pump versions are uni-directional, allowing higher selfpriming speeds (refer to pages 9, 11 and 40, 42).

The illustration to the right shows direction of flow versus shaft rotation. In a motor application, the shaft turns clockwise when port **B** (black arrow) is pressurized, and counter clockwise when port **A** (open arrow) is pressurized.

In a pump application where the shaft turns clock-wise, port B is the inlet port and should be connected to tank; when the shaft turns counter clockwise, port A is the inlet port.

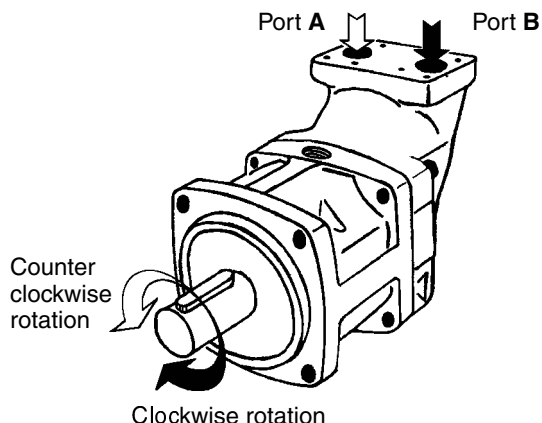

Hydraulic fluids

Ratings and performance data for series F11/F12 are based on operating with good quality, contamination-free, petroleum-based fluids.

Hydraulic fluids type HLP (DIN 51524), automatic transmission fluids type A, or API CD engine oils can be used.

Fire resistant fluids (when used under modified operating conditions) and synthetic fluids may also be suitable.

NOTE:

When operating the F11/F12 as a pump above the selfpriming speed (valid for both the pump and motor versions), the inlet must be sufficiently pressurized. Increased noise and deteriorating performance may otherwise be experienced.

For further information refer to 'Selfpriming speed and required inlet pressure' on pages 11 and 42.

Operating temperature

The following temperatures should not be exceeded (type V FPM shaft seals):

Main circuit 80 °C

Drain circuit: 115 °C.

NBR shaft seals (type N) can be used to 90 °C drain fluid temperature.

NOTE: The temperature should be measured at the utilized drain port.

Continuous operation may require case flushing in order to meet the viscosity and temperature limitations.

The following table shows operating speeds, above which flushing is usually required, as well as suggested flow through the case.

F11/F12 in series operation

When running F11/F12 in series at higher pressure levels,

Please contact Parker Hannifin for further information.

Frame size	Speed [rpm]	Flow [l/min]
F11-5	5500	1 - 2
F11-6	4500	2 - 3
F11-10	4500	2 - 3
F11-12	4500	2 - 3
F11-14	4500	2 - 3
F11-19	4000	2 - 4

Frame size	Speed [rpm]	Flow [l/min]
F12-30	3500	4 - 8
F12-40	3000	5 - 10
F12-60	3000	7 - 14
F12-80	2500	8 - 16
F12-90	2500	8 - 16
F12-110	2300	9 - 18
F12-125	2300	9 - 18
F12-152/162/182	2200	10 - 20
F12-250	1800	12 - 22

Viscosity

The ideal operating range is 15 to 30 mm²/s [cSt].
 At operating temperature, the viscosity (of the drain fluid) should be kept above 8 mm²/s [cSt].
 At start-up, the viscosity should not exceed 1000 mm²/s [cSt]

Filtration

To obtain the highest service life of the F11/F12, the fluid cleanliness should meet or exceed ISO code 20/18/13 (ISO 4406).
 During normal operating conditions, a 10 µm (absolute) filter is recommended.

Case pressure

The service life of the shaft seal ring is affected by the speed of the motor and the case drain pressure and it can decrease with an increase in the frequency of pressure peaks.
 Note, seal life can be shorter at unfavourable operating conditions (high temperature, low oil viscosity, contaminated oil).
 The table below shows recommended case pressure as a function of shaft speed.

Shaft speed	[rpm]	1500	3000	4500	6000	max
F11-5, -6, -10, -12, -14, -19	[bar]	0.5 - 10	0.5 - 7.0	1.0 - 5.0	2.0 - 5.0	3.0 - 5.0
F12-30, -40, -60, -80, -90	[bar]	0.5 - 8	0.5 - 6.0	1.0 - 4.5	2.0 - 4.0	-
F12-110, -125, -152, -162, -182, -250	[bar]	0.5 - 6	1.0 - 4.0	2.0 - 4.0	-	-

The case pressure must be equal to or greater than the external pressure on the shaft seal ring.

To secure correct case pressure and lubrication, a spring loaded check valve, 1-3 bar, in the drain line (shown on next page) is recommended.

Note.
Contact Parker Hannifin for information when operating at high speeds.

Required inlet pressure

The motor may operate as a pump under certain conditions.

When this occurs, a minimum pressure must be maintained at the inlet port; increased noise and gradually deteriorating performance due to cavitation may otherwise be experienced.

A 15 bar inlet pressure, measured at the motor inlet port, satisfies most operating conditions.

Contact Parker Hannifin for more specific information on inlet pressure requirements.

Case drain connections

Series F11/F12 have two drain ports, **C** and **D**, while F12-110 and -125 have an additional port, **E**.

The uppermost drain port (such as port C in the illustration below) should always be utilized.

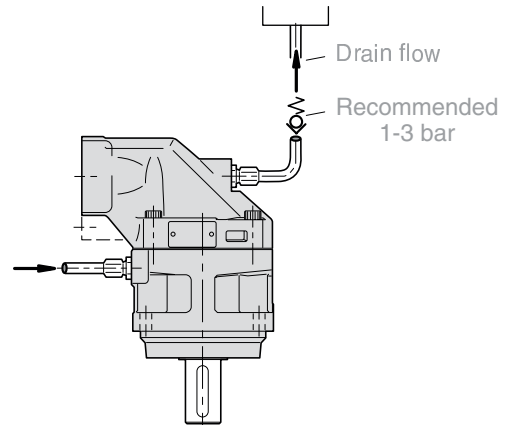
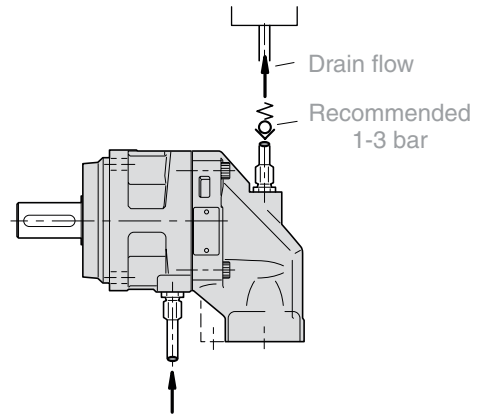
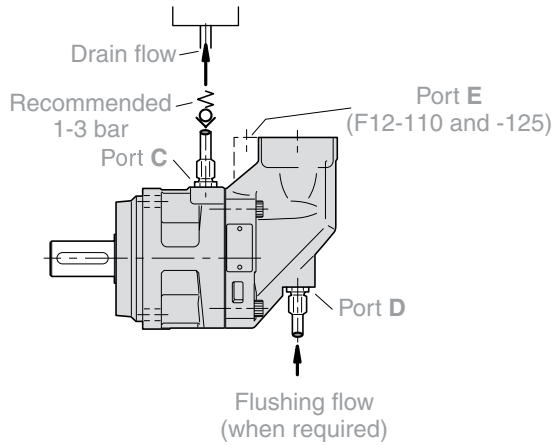

In mounting positions such as 'shaft up' (below) a spring loaded check valve should be installed in the drain line in order to insure a sufficiently high oil level in the case.

Preferably, the drain line should be connected directly to the reservoir.

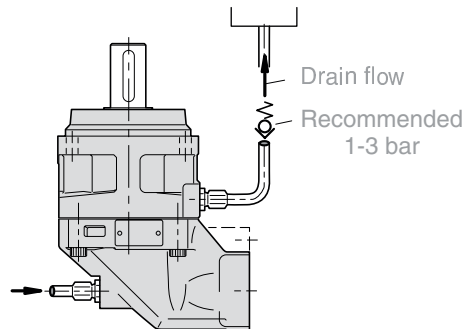
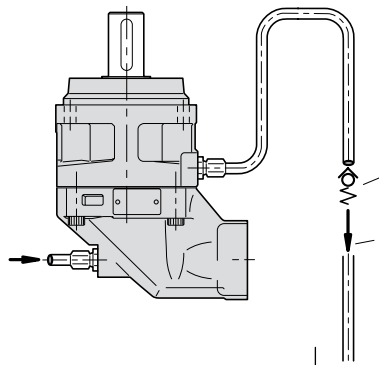

Before start-up

Make sure the F11/F12 case as well as the entire hydraulic system is filled with a recommended fluid.

The internal leakage, especially at low operating pressures, is *not* sufficient to provide lubrication at start-up.

NOTE:

- To avoid cavitation and obtain a low noise level as well as reduced heat generation, tubes, hoses and fittings must be adequately dimensioned.
- Preferably, the suction line flow speed should be 0.5 to 1 m/s, and pressure line flow speeds 3 to 5 m/s.

5

Parker Worldwide

Europe, Middle East, Africa

AE – United Arab Emirates,
Dubai

Tel: +971 4 8127100
parker.me@parker.com

AT – Austria, Wiener Neustadt

Tel: +43 (0)2622 23501-0
parker.austria@parker.com

AT – Eastern Europe, Wiener
Neustadt

Tel: +43 (0)2622 23501 900
parker.easteurope@parker.com

AZ – Azerbaijan, Baku

Tel: +994 50 2233 458
parker.azerbaijan@parker.com

BE/LU – Belgium, Nivelles

Tel: +32 (0)67 280 900
parker.belgium@parker.com

BG – Bulgaria, Sofia

Tel: +359 2 980 1344
parker.bulgaria@parker.com

BY – Belarus, Minsk

Tel: +48 (0)22 573 24 00
parker.poland@parker.com

CH – Switzerland, Etoy

Tel: +41 (0)21 821 87 00
parker.switzerland@parker.com

CZ – Czech Republic, Klecany

Tel: +420 284 083 111
parker.czechrepublic@parker.com

DE – Germany, Kaarst

Tel: +49 (0)2131 4016 0
parker.germany@parker.com

DK – Denmark, Ballerup

Tel: +45 43 56 04 00
parker.denmark@parker.com

ES – Spain, Madrid

Tel: +34 902 330 001
parker.spain@parker.com

FI – Finland, Vantaa

Tel: +358 (0)20 753 2500
parker.finland@parker.com

FR – France, Contamine s/Arve

Tel: +33 (0)4 50 25 80 25
parker.france@parker.com

GR – Greece, Piraeus

Tel: +30 210 933 6450
parker.greece@parker.com

HU – Hungary, Budaörs

Tel: +36 23 885 470
parker.hungary@parker.com

IE – Ireland, Dublin

Tel: +353 (0)1 466 6370
parker.ireland@parker.com

IL – Israel

Tel: +39 02 45 19 21
parker.israel@parker.com

IT – Italy, Corsico (MI)

Tel: +39 02 45 19 21
parker.italy@parker.com

KZ – Kazakhstan, Almaty

Tel: +7 7273 561 000
parker.easteurope@parker.com

NL – The Netherlands, Oldenzaal

Tel: +31 (0)541 585 000
parker.nl@parker.com

NO – Norway, Asker

Tel: +47 66 75 34 00
parker.norway@parker.com

PL – Poland, Warsaw

Tel: +48 (0)22 573 24 00
parker.poland@parker.com

PT – Portugal

Tel: +351 22 999 7360
parker.portugal@parker.com

RO – Romania, Bucharest

Tel: +40 21 252 1382
parker.romania@parker.com

RU – Russia, Moscow

Tel: +7 495 645-2156
parker.russia@parker.com

SE – Sweden, Spånga

Tel: +46 (0)8 59 79 50 00
parker.sweden@parker.com

SK – Slovakia, Banská Bystrica

Tel: +421 484 162 252
parker.slovakia@parker.com

SL – Slovenia, Novo Mesto

Tel: +386 7 337 6650
parker.slovenia@parker.com

TR – Turkey, Istanbul

Tel: +90 216 4997081
parker.turkey@parker.com

UA – Ukraine, Kiev

Tel: +48 (0)22 573 24 00
parker.poland@parker.com

UK – United Kingdom, Warwick

Tel: +44 (0)1926 317 878
parker.uk@parker.com

ZA – South Africa, Kempton Park

Tel: +27 (0)11 961 0700
parker.southafrica@parker.com

North America

CA – Canada, Milton, Ontario

Tel: +1 905 693 3000

US – USA, Cleveland

Tel: +1 216 896 3000

Asia Pacific

AU – Australia, Castle Hill

Tel: +61 (0)2-9634 7777

CN – China, Shanghai

Tel: +86 21 2899 5000

HK – Hong Kong

Tel: +852 2428 8008

IN – India, Mumbai

Tel: +91 22 6513 7081-85

JP – Japan, Tokyo

Tel: +81 (0)3 6408 3901

KR – South Korea, Seoul

Tel: +82 2 559 0400

MY – Malaysia, Shah Alam

Tel: +60 3 7849 0800

NZ – New Zealand, Mt Wellington

Tel: +64 9 574 1744

SG – Singapore

Tel: +65 6887 6300

TH – Thailand, Bangkok

Tel: +662 186 7000

TW – Taiwan, Taipei

Tel: +886 2 2298 8987

South America

AR – Argentina, Buenos Aires

Tel: +54 3327 44 4129

BR – Brazil, Sao Jose dos Campos

Tel: +55 800 727 5374

CL – Chile, Santiago

Tel: +56 2 623 1216

MX – Mexico, Toluca

Tel: +52 72 2275 4200



EMEA Product Information Centre

Free phone: 00 800 27 27 5374

(from AT, BE, CH, CZ, DE, DK, EE, ES, FI, FR, IE, IL,
IS, IT, LU, MT, NL, NO, PL, PT, RU, SE, SK, UK, ZA)

US Product Information Centre

Toll-free number: 1-800-27 27 537

www.parker.com