

RAILTECH

M A T W E L D

Ⓞ DELACHAUX GROUP

HYDRAULIC TRACK TOOLS



SERVICE
TRAINING
INNOVATION



- POWER UNITS
- GRINDERS
- WELD SHEARS
- RAIL SAWS
- DRILLS
- IMPACTS
- SPIKE PULLERS
- SPIKE DRIVERS
- TAMPERS
- OTHER RAIL PRODUCTS

V1.11.11

AMERICAN-MADE TOOLS PROUDLY SERVING THE RAILROAD INDUSTRY WORLDWIDE



Contact Information

Railtech Matweld, Inc.
25 Interstate Drive
P.O. Box 349
Napoleon, OH 43545

Phone: (419) 591-3770
1-888-MATWELD

Fax: (419) 599-3630

customerservice@matweld.com
www.matweld.com



Railtech International and Matweld, Inc. are proud to announce the merging of companies and talents to expand into the future for the railroad industry. Railtech Matweld is now a division of Railtech International, producing American-made tools and proudly serving the railroad industry through innovation, training and service.

Railtech Matweld, Inc. is an international company offering high quality railway products for the entire railroad industry and is your single source for Hydraulic tools and equipment. As an industry specialist, we will meet customer tool and product requirements with current, or custom, manufacturing capabilities that meet specifications for unique applications within urban and transit rail systems.

Railtech Matweld offers after-the-sale training, service and single-source purchase for all items sold. We assist in local support training for your employees or a local support company in your area.

RAILTECH

M A T W E L D

Ⓞ DELACHAUX GROUP

POWER UNITS

00100K DUAL CIRCUIT POWER UNIT

The Railtech Matweld Dual Circuit Power Unit is designed to deliver two 5 GPM or one 10 GPM circuits at 2000 PSI. A power unit-mounted hose reel, with a 50 foot hose, is available, as well as various carts and provisions to move the machine manually or power assisted.

ACCESSORIES:

- 00187-Kit- 00100K Lift Handle Kit
- 00195- Power Point
- 02326- Hose Reel with 50' hose and mounting bracket
- 06300- Power Unit Mobility Cart
- 06327- Power Unit Mobility Kit
- 06600- Power Unit Transport Cart

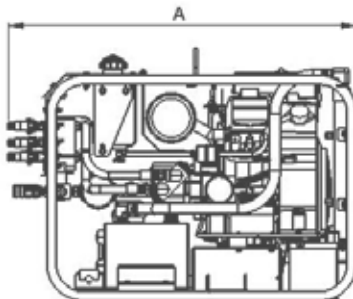
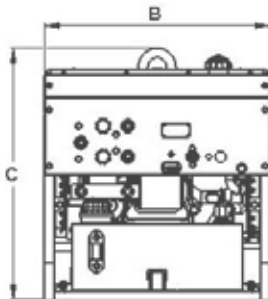

ENGINE 23hp KOHLER FUEL: GASOLINE 4 US GAL (15.14L) START: ELECTRIC 12V
HYDRAULICS (2) 5 GPM (19 LPM) OR (1) 10 GPM (38 LPM) FLUID: HYDRAULIC 5 US GAL (18.9L) 2000 PSI (140 bar)
DIMENSIONS A: 37" (94.0cm) B: 24" (60.9cm) C: 27" (68.5cm)
WEIGHT 321 lbs (145.6 kg)

02900A DIESEL POWER UNIT

The Railtech Matweld 02900 Diesel Power Unit can be optionally equipped with catalytic converter, mobility kit and mounted hose reel. Engine protection devices are installed to protect the engine from low oil and high temperature.

ACCESSORIES:

- 02326- Hose Reel with 50' hose and mounting bracket
- 02900C- w/Catalytic Converter
- 02998- Power Unit Lift Handle Kit
- 06100- Tamper Cart w/ 2 hose reels

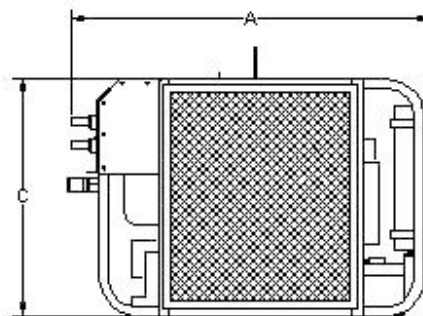
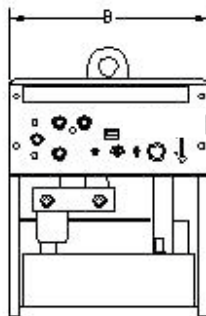

ENGINE 18hp KUBOTA MSHA CERTIFIED FUEL: DIESEL 4 US GAL (15.14L) START: ELECTRIC 12V
HYDRAULICS (2) 5 GPM (19 LPM) OR (1) 10 GPM (38 LPM) FLUID: HYDRAULIC 5 US GAL (18.9L) 2000 PSI (140 bar)
DIMENSIONS A: 38" (96.5cm) B: 24" (70cm) C: 36" (91.4cm)
WEIGHT 465 lbs (210 kg)

05500 TWIN POWER UNIT W/ GENERATOR
 05550 w/o GENERATOR

The Railtech Matweld Twin Power Unit is designed to deliver two 5 GPM circuits or one 10 GPM circuit at 2000 PSI for hydraulic tool operations. With the additional 5000 watt generator, AC powered equipment may be operated simultaneously. Quiet and efficient, this unit gives maintenance-of-way crews the versatility to operate safely and cost effectively in adverse conditions with a variety of equipment.

ACCESSORIES:

- 06300- Power Unit Mobility Cart
- 02326- Hose Reel with 50' hose and mounting bracket

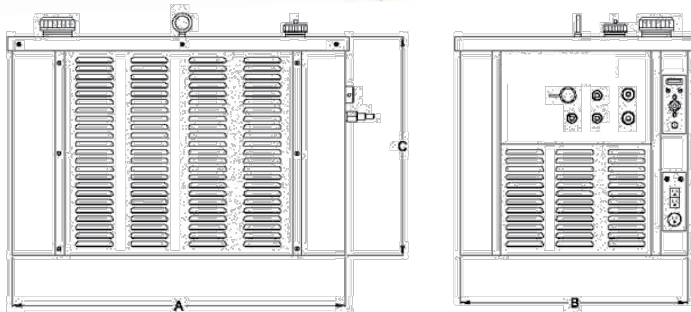

<p>GENERATOR 500W 120/240V SINGLE PHASE @ 60hz 120V - 41.6 AMP RATING 240V - 20.8 AMP RATING</p>
<p>ENGINE 23hp KOHLER FUEL: GASOLINE 4 US GAL (15.14L) START: ELECTRIC 12V</p>
<p>HYDRAULICS (2) 5 GPM (19 LPM) OR (1) 10 GPM (38 LPM) FLUID: HYDRAULIC 5 US GAL (18.9L) 2000 PSI (140 bar)</p>
<p>DIMENSIONS A: 36" (91.4cm) B: 25" (63.5cm) C: 32" (81.3cm)</p>
<p>WEIGHT 506 lbs (229.5 kg)</p>

02050K 5 GALLON POWER UNIT

The Railtech Matweld Single Circuit Power Unit is designed to deliver one 5 GPM circuit. Designed for inspection vehicles where size and weight are primary concerns, this unit is perfect for small jobs.

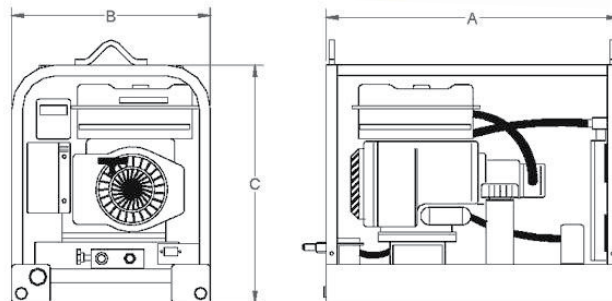

ENGINE

9hp KHOLER
FUEL: GASOLINE
7.4 QTS (7.0 L)
START: ELECTRIC w/PULL

HYDRAULICS

(1) 5 GPM (19 LPM)
FLUID: HYDRAULIC
3.5 US GAL (13.2L)
2000 PSI (140 bar)

DIMENSIONS

A: 27½" (69.8cm)
B: 18" (45.7cm)
C: 26" (66cm)

WEIGHT

230 lbs
(104.3 kg)

03700A ELECTRIC POWER UNIT

The Railtech Matweld Electric Power Unit is designed to deliver two 5 GPM circuits or one 10 GPM circuit at 2000 PSI for hydraulic tool operations in buildings or other closed environments. This power unit is equipped with heavy duty wheels for mobility.

ACCESSORIES:
02326- Hose Reel with 50' hose and mounting bracket

HERTZ REQUIREMENTS VARY BY COUNTRY.

SPECIFY REQUIREMENTS WHEN ORDERING

shown with mounted hose reel

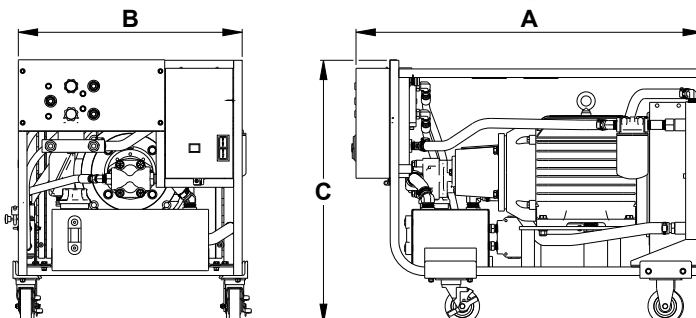

<p>ENGINE</p> <p>20hp ELECTRIC 240/360/480 VAC 3 PHASE CHECK HERTZ REQUIREMENTS</p>
<p>HYDRAULICS</p> <p>(2) 5 GPM (19 LPM) OR (1) 10 GPM (38 LPM)</p> <p>FLUID: HYDRAULIC 5 US GAL (18.9L) 2000 PSI (140 bar)</p>
<p>DIMENSIONS</p> <p>A - 41" (104.1cm) B - 30" (76.2cm) C - 33" (83.8cm)</p>
<p>WEIGHT</p> <p>487 lbs (220.8 kg)</p>

06700 MOBILE DIESEL POWER UNIT

The Railtech Matweld Mobile Diesel Power Unit is a 2WD power unit designed for remote areas that are not readily accessible by conventional high rail methods. The handle bar style controls provide positive steering with forward and reverse travel at your fingertips. Track wheel outriggers allow for easy mobility down the rail.



B



C

ENGINE

19hp LAMBARDINI
FUEL: DIESEL
4 US GAL (15.14L)
START: ELECTRIC 12V

HYDRAULICS

(2) 5 GPM (19 LPM)
OR
(1) 10 GPM (38 LPM)
FLUID: HYDRAULIC
5 US GAL (18.9L)
2000 PSI (140 bar)

DIMENSIONS

A: 45" (114.3cm)
B: 32" (81.3cm)
C: 38½" (97.8cm)

WEIGHT

585 lbs
(265 kg)

06300

POWER UNIT MOBILITY CART

The Railtech Matweld Mobility Cart is light-weight and highly versatile, it is simple to set-up and allows the operator to easily maneuver a power unit both on and off the rail. It can also be used as a tool trolley when no power unit is secured to it. The handles and rollers on this unit collapse for compact storage.



DIMENSIONS

29" (73.6cm)

39" (99cm)

18¹/₄" (46.3cm)

WEIGHT

96 lbs

(43.5 kg)

06600

POWER UNIT TRANSPORT CART

The Railtech Matweld Power Unit Transport Cart is a 2WD mobility package designed to transport Matweld power units to remote areas that are not readily accessible by conventional high-rail methods. The handle bar-style controls provide positive steering with forward and reverse controls at your fingertips. Power to operate the cart (5 GPM @ 2000 PSI) is provided by the power unit being transported.



MAX PAYLOAD

425 lbs
(953 kg)

DIMENSIONS

LENGTH:
HANDLE COLLAPSED
45" (114.3cm)
HANDLE EXTENDED
57" (144.7cm)

WIDTH: 33" (83.8cm)

HEIGHT: 36" (91.4cm)

TIRES

FLAT-FREE
FOAM FILLED

WEIGHT

187 lbs
(84.8 kg)

09800 GASOLINE TRACK ROVER
 09900 DIESEL TRACK ROVER

The Railtech Matweld Track Rover is a hydraulic 4WD mobile work cart powered by a 22hp Kohler Engine. It is ideal for derailment work or to transport railroad maintenance tools and/or supplies to remote areas not easily accessible by conventional high rail methods. The hydraulic-powered dump bed can be converted to a flat bed by removing bed side rails. A 12V DC standard power point is equipped and can be utilized with optional inverter for 120 volt application. Front and rear high intensity halogen lights are provided. Operator control is remote via a hand held radio transmitter.

ACCESSORIES:

- 12 Volt Inverter
- 5000 Watt Generator
- Flood Light Package
- Hydraulic Dump Bed Option
- 00300- 50' Transmission Hose
- 00200- 25' Transmission Hose
- 1500 lb., 12 Volt Power Winch



<p>MAX PAYLOAD 1,000 lbs (454 kg)</p>
<p>HYDRAULICS (2) 5 GPM (19 LPM) OR (1) 10 GPM (38 LPM) FLUID: HYDRAULIC 5 US GAL (18.9L) 2000 PSI (140 bar)</p>
<p>DIMENSIONS L: 71" (180.3cm) W: 50" (127cm) H: 36" (91.4cm) BED : 40" x 67" (101.6cm x 170.2cm) GROUND CLEARANCE: 11" (27.9cm)</p>
<p>TIRES ALL-TERRAIN AIR 26" x 9" x 12" WHEEL BASE: 40½" (102.9cm)</p>
<p>WEIGHT 486 lbs (220 kg)</p>

03000 HYDRAULIC MANIFOLD CIRCUIT

The Railtech Matweld Hydraulic Manifold Circuit is a self contained flow and directional control assembly. The manifold can be installed on any vehicle which is already equipped with a hydraulic system capable of producing at least 10 GPM at 2000 PSI. The manifold can be installed and takes up very little space. The manifold circuit provides a safe and cost effective way of adding hydraulic tool capabilities to your existing fleet of equipment.

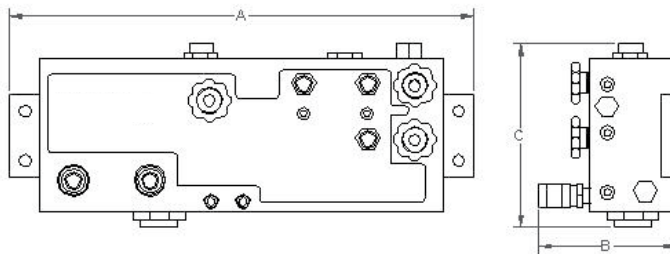

PRESSURE
 2000 PSI (140 bar)

FLOW
 (2) 5 GPM (19 LPM)
 OR
 (1) 10 GPM (38 LPM)

DIMENSIONS
 A - 18 $\frac{3}{4}$ " (47.6cm)
 B - 7" (17.8cm)
 C - 8 $\frac{1}{2}$ " (21.6cm)

WEIGHT
 31 lbs
 (14 kg)

06500 HYDRAULIC INTENSIFIER

The Railtech Matweld Hydraulic Intensifier is a complete, self-contained, safe, compact unit. The intensifier is designed to operate off of a 2000 PSI, 5 GPM power source. All Intensifiers have a relief pressure adjustable up to 10,000 PSI. This ensures a safe operation, not allowing the cylinders to receive excessive pressures.

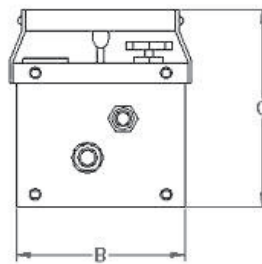
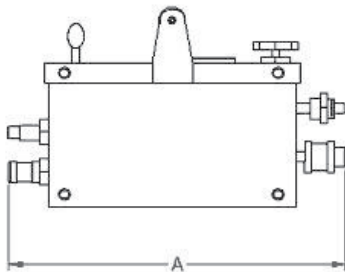

FLOW

5 GPM (19 LPM)

PRESSURE
2000 PSI (140 bar)

DIMENSIONS

A - 15" (38.1cm)
B - 8" (20.3cm)
C - 10½" (26.7cm)

WEIGHT

33 lbs
(15 kg)

RAILTECH

M A T W E L D

Ⓞ DELACHAUX GROUP

GRINDERS

09200A PRECISION FROG GRINDER

The Railtech Matweld Precision Frog Grinder is a hydraulic powered, track mounted machine that provides a precision guide-frame with multiple axis adjustment enabling the operator to make consistent refinishing grinds.

ACCESSORIES:

- 00499 - 8" x 1" x 5/8" Hub Grinding Wheel
- 09295 - 2' Rail Kit
- 09299 - 4" x 3" x 5/8"-11" Grinding Stone

- 09290 - 2" Stone Adaptor Kit
- 09295 - Rail and 2" Adaptor Kit
- 09298 - 2" x 8" x 1" Stone



FLOW 10 GPM (38 LPM)
PRESSURE 2000 PSI (140 bar)
RPM 4000
DIMENSIONS GRINDER L:17" W:35" H:32" BASE: L: 57½" W: 40" H: 8"
WEIGHT BASE: 46 lbs (20.8 kg) GRINDER: 88 lbs (39.9 kg) OVERALL: 134 lbs (60.8 kg)

06000 PROFILE GRINDER

The Railtech Matweld Profile Grinder is a lightweight, precision grinding machine. The grinder is designed specifically for finish grinding of field welds and will grind the top and sides of the rail to the original profile. Optional Model No. 06050 is available with a safety trigger operating lever system.

ACCESSORIES:

- 02199 - 6" x 3" x 5/8" Hub Grinding Stone
- 06009 - Spark Shield

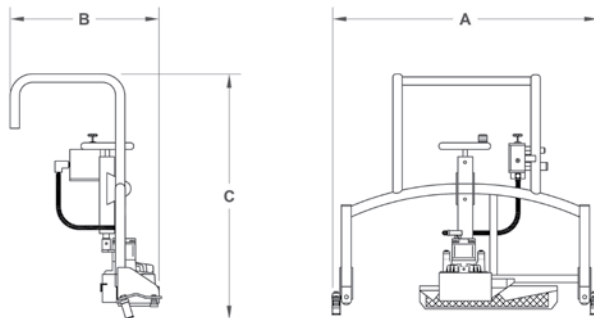

FLOW 10 GPM (38 LPM)
PRESSURE 2000 PSI (140 bar)
RPM 4000
DIMENSIONS A - 34½" (87.63cm) B - 20" (51cm) C - 32" (81.3cm)
WEIGHT 67 lbs (30.4 kg)

06950A MULTI-PURPOSE GRINDER

The Railtech Matweld Multi-Purpose Grinder allows operators to remain in an ergonomic upright position while performing field weld grinding. The adjustable rear handle positions easily for the operators preferred height and comfort or lowered and swiveled around for compact storage.

ACCESSORIES:

00499 - 8" x 1' x 5/8" Hub Grinding Stone

Patent no. 6,663,476

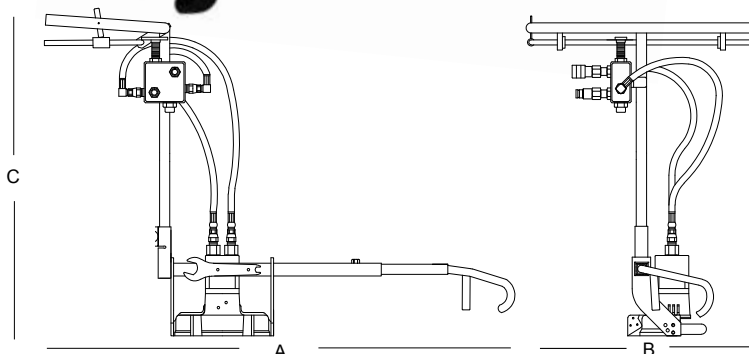

<p>FLOW 10 GPM (38 LPM)</p>
<p>PRESSURE 2000 PSI (140 bar)</p>
<p>RPM 4000</p>
<p>DIMENSIONS A - 40" (101.6cm) B - 22" (55.9cm) C - 34" (86.4cm)</p>
<p>WEIGHT 43 lbs (19.5 kg)</p>

06950 MULTI-PURPOSE GRINDER

The Railtech Matweld Multi-Purpose Grinder allows operators to remain in an ergonomic upright position while performing multiple grinding tasks. Lightweight, and with adjustable positions for the grinding head and rail guide, field welds, switch points and frogs can be easily ground with this one tool. The adjustable rear handle positions easily for the operators preferred height and comfort or lowered and swiveled around for compact storage.

ACCESSORIES:

00499 - 8" x 1" x 5/8" Hub Grinding Stone

Patent no. 6,663,476

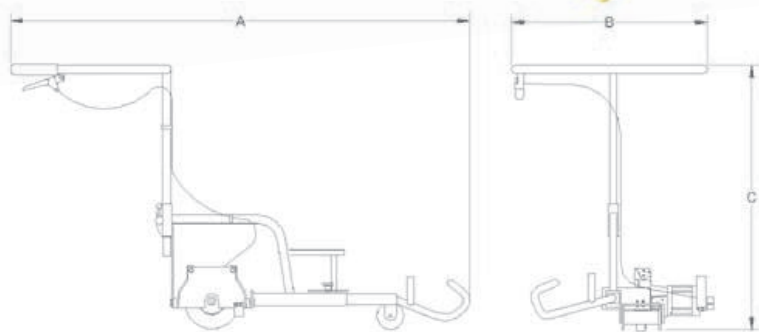

FLOW 10 GPM (38 LPM)
PRESSURE 2000 PSI (140 bar)
RPM 4000
DIMENSIONS A - 40" (101.6cm) B - 24" (60.7cm) C - 34" (86.4cm)
WEIGHT 52 lbs (23.6 kg)

- 05900 FROG / PROFILE GRINDER
- 05950 FROG / PROFILE GRINDER W/ TRIGGER

The Railtech Matweld Frog/Profile Grinder is a lightweight, precision grinding machine. The grinder is designed for frog and finish grinding of field welds. The roll-over feature makes ergonomic grinding of the rail to the original profile easy. An optional detachable Frog Grinding Outrigger is available for grinding Frogs. The flap-type spark guard prevents sparks from being discharged on adjacent combustible material.

ACCESSORIES:

- 02199 - Grinding Stone
- 05999 - Grinding Outrigger
- 05970 - Spark Shield Kit

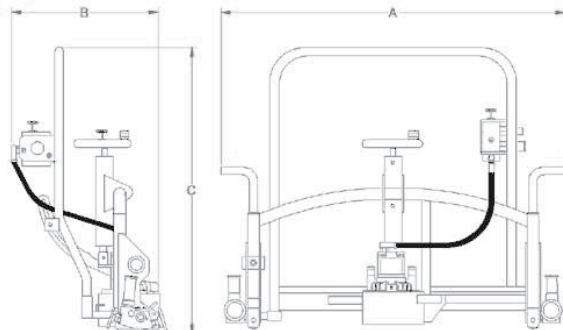

<p>FLOW 10 GPM (38 LPM)</p>
<p>PRESSURE 2000 PSI (140 bar)</p>
<p>RPM 4000</p>
<p>DIMENSIONS A - 40" (101.6cm) B - 16" (40.6cm) C - 34" (86.4cm)</p>
<p>WEIGHT 85 lbs (38.5 kg)</p>

00700 / 00700C SURFACING GUIDE GRINDER

The Railtech Matweld Surfacing Guide is a rugged but lightweight grinding attachment designed specifically for grinding the top of the rail. It is excellent for the finish grinding of field welds or rail end repairs. The extended guard offers excellent protection for the operator.

Note: Model 00700C has factory installed Type 6 Stone Adaptor (00733-Kit) for use exclusively for a type 6 stone (00797)

ACCESSORIES:

- 00733-Kit - Type 6 Stone Adaptor
- 00797 - Type 6 Stone 8" x 2" x 1½"
- 00799 - 8" x 2" x 4" Cup Stone (exclusive use with model 00700)

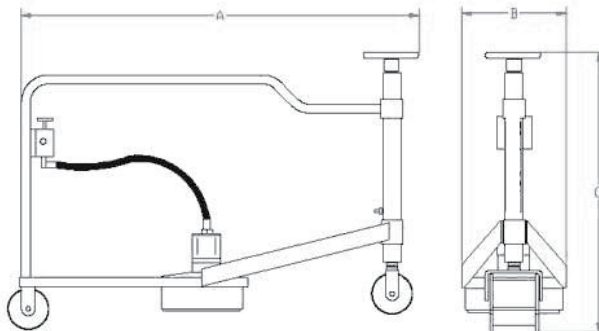

FLOW
10 GPM (38 LPM)

PRESSURE
2000 PSI (140 bar)

RPM
4000

DIMENSIONS
A - 39" (99cm)
B - 12" (30.5cm)
C - 26" (66cm)

WEIGHT
75 lbs
(34 kg)

STRAIGHT STONE GRINDER

04600 CW ROTATION

04650 CW ROTATION W/ TRIGGER

04700 CCW ROTATION

04750 CCW ROTATION W/ TRIGGER

The Railtech Matweld Straight Stone Grinder is a powerful and safe grinding tool for use on field welds, frogs, switch points, etc. The tool has an on-off valve or trigger, high strength aluminum housing and rigid handles for safe use by the operator.

NOTE: Rotation direction is determined by looking directly at the face of the installed grinding stone.

ACCESSORIES:

00499 - 8" x 1" x 5/8" Grinding Stone

046009 - 1" Stone Adaptor

046015 - Slotting Guide Kit



04650 CW Rotation w/Trigger

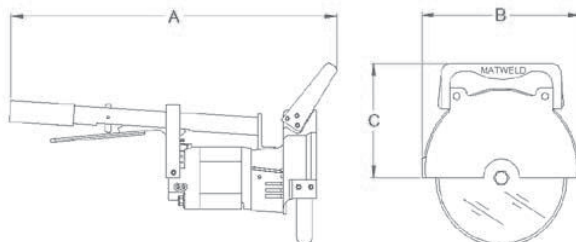

FLOW 10 GPM (38 LPM)
PRESSURE 2000 PSI (140 bar)
RPM 4000
DIMENSIONS A - 21" (53.3cm) B - 8" (20.3cm) C - 7½" (19cm)
WEIGHT 20 lbs (9 kg)

07500 CHAMFER TOOL

The Railtech Matweld Chamfer Tool is a light weight powerful maintenance-of-way tool ideal for chamfering drilled holes. Utilizing low rpm & high torque permits the operator safe and long lasting service of chamfer bits.

ACCESSORIES:

07550 - Chamfer Bit: Hole Chamfer range from $\frac{5}{8}$ " to $1\frac{3}{4}$ "

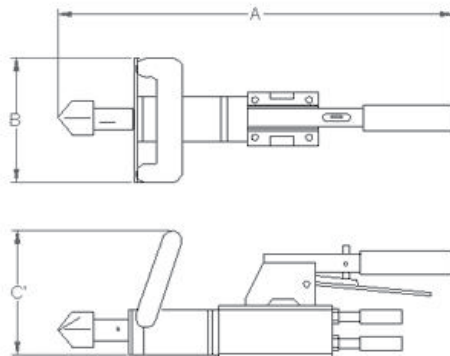
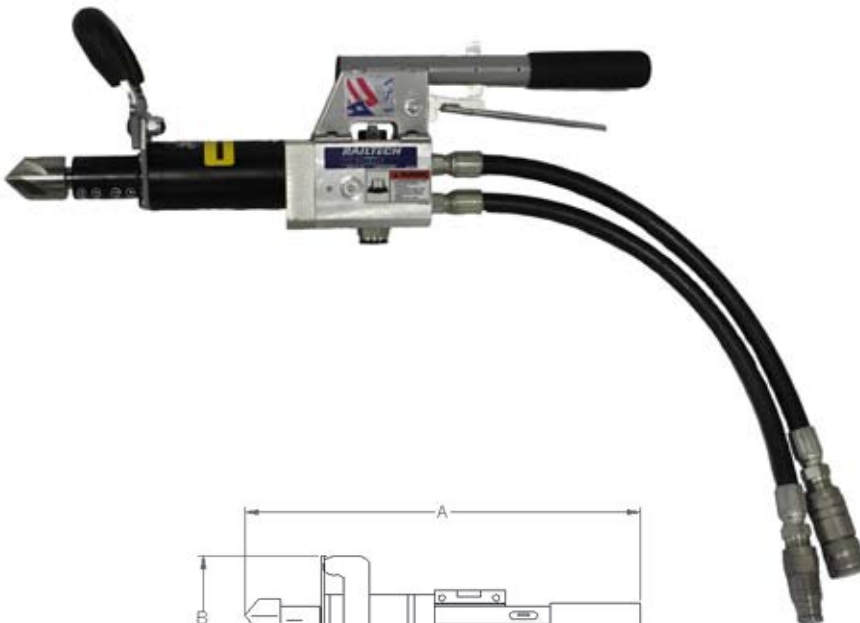

FLOW 5 GPM (19 LPM) OR 10 GPM (38 LPM)
PRESSURE 2000 PSI (140 bar)
RPM 160
DIMENSIONS A - 14" (35.6cm) B - 8" (20.3cm) C - 7½" (19cm)
WEIGHT 18 lbs (8.16 kg)

- 04800 6" CUP STONE GRINDER W/ ON/OFF VALVE
- 04850 6" CUP STONE GRINDER W/ SAFETY TRIGGER

The Railtech Matweld Cup Stone Grinder is designed for grinding the tops of frogs and rail. The unique stone adjustment feature allows the operator to easily adjust the guard as the stone wears, without the need for wrenches. The wrap around handle design gives the operator complete control of the tool.

ACCESSORIES:

02199 - 6" x 3" x 5/8" Grinding Stone



<p>FLOW 10 GPM (38 LPM)</p>
<p>PRESSURE 2000 PSI (140 bar)</p>
<p>RPM 4000</p>
<p>DIMENSIONS A - 9 3/4" (24.77cm) B - 10" (25.4cm) C - 11 1/2" (29.2cm)</p>
<p>WEIGHT 26 lbs (11.8 kg)</p>

00600

8" CUP STONE GRINDER

The Railtech Matweld 8" Cup Stone Grinder is designed for use in grinding the tops of frogs and rail. The unique stone adjustment feature allows the operator to easily adjust the guard as the stone wears without the need for wrenches. The double handles give the operator complete control of the tool.

Note: Model 00600C has factory installed Type 6 Stone Adaptor (00733-Kit) for use exclusively for a type 6 stone (00797).

ACCESSORIES:

00799 - 8" x 2" x 4" Plate Mounted Cup Stone (exclusive use with the model 00600)

00733-KIT - Type 6 Stone Adaptor Kit

00797 - 8" x 2" x 1½" Type 6 Stone



A

B



C

FLOW
10 GPM (38 LPM)

PRESSURE
2000 PSI (140 bar)

RPM
4000

DIMENSIONS
A - 16½" (41.9cm)
B - 10" (25.4cm)
C - 9" (22.9cm)

WEIGHT
28 lbs
(12.7 kg)

05400 ANGLE GRINDER

The Railtech Matweld Angle Grinder is a multipurpose grinding and cutting tool which accepts a variety of accessory attachments. It can be used for removing rust and scale, grinding rail welds, frog points, or anywhere a detailed grind is required. The head assembly is adjustable to rotate 360 degree for operator comfort.

ACCESSORIES:

Grinding Stones and cut-off wheels available. Specify size.

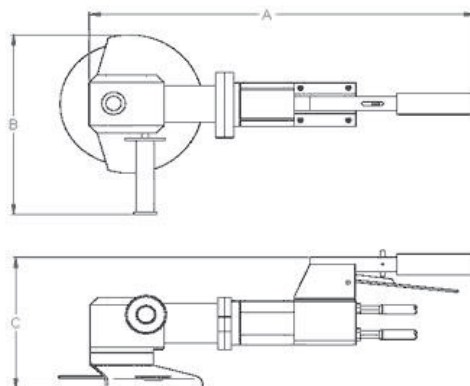

FLOW 10 GPM (38 LPM)
PRESSURE 2000 PSI (140 bar)
RPM 4000
DIMENSIONS A - 21" (53.3cm) B - 8" (20.3cm) C - 12" (30.4cm)
WEIGHT 19 lbs (8.62 kg)

RAILTECH

M A T W E L D

Ⓞ DELACHAUX GROUP

SAWS / WELD SHEARS

03900A REVERSING RAIL SAW

The Railtech Matweld Reversing Rail Saw is a hydraulic powered abrasive rail saw that can cut rail from either side of the rail safely without disconnecting or realignment; simply pivoting the saw to the other side of the rail provides the flexibility and safety that is needed on track.

ACCESSORIES:

- 00897 - 14" Saw Blades
- 00899 - 16" Saw Blades

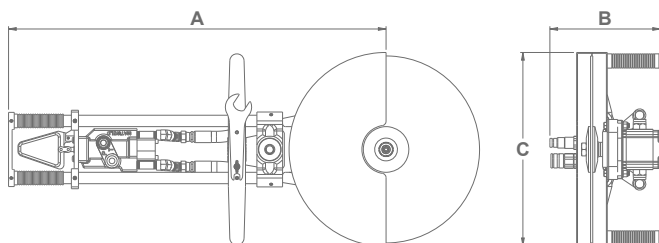

<p>FLOW 10 GPM (38 LPM)</p>
<p>PRESSURE 2000 PSI (140 bar)</p>
<p>RPM 3200</p>
<p>DIMENSIONS A - 36" (91.4cm) B - 10" (25.4cm) C - 17" (43.2cm) CLAMP: 36" x 8" x 11"</p>
<p>WEIGHT 40 lbs (18.1 kg) CLAMP 21 lbs (9.5 kg)</p>

00800A RAIL SAW

The Railtech Matweld Rail Saw is a hydraulic powered abrasive rail saw that uses a 14" or 16" diameter blade to cut rail. A sturdy pivot arm securely clamps to the rail and guides the saw during operation. Free axis movement of the tool allows cutting on either side of the rail and clean separations average well under two minutes. Sturdy construction and quality components ensure low maintenance and long life of the tool.

ACCESSORIES:

- 00897 - 14" Saw Blades
- 00899 - 16" Saw Blades

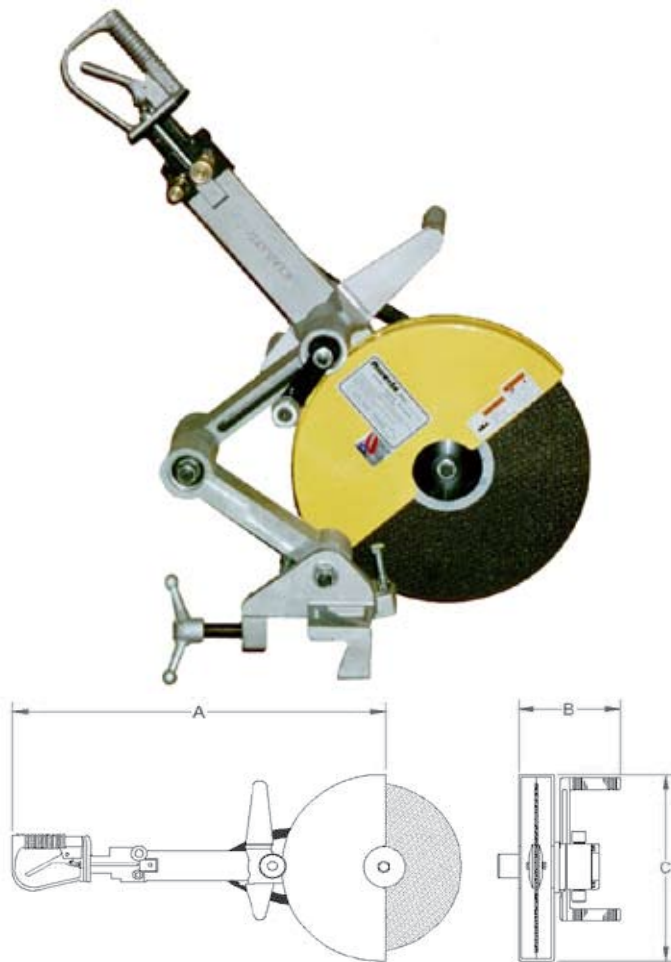

FLOW 10 GPM (38 LPM)
PRESSURE 2000 PSI (140 bar)
RPM 3200
DIMENSIONS A - 36" (91.4cm) B - 10" (25.4cm) C - 17" (43.2cm) CLAMP: 36" x 8" x 11"
WEIGHT 35 lbs (15.8 kg) CLAMP 21 lbs (9.5 kg)

05100A WELD SHEAR

The Railtech Matweld Weld Shear is light-weight and highly efficient. Spring centered flow control valve permits safe and precise shearing of a thermite weld. The shield totally protects fittings and hoses and the adjustable hold downs are self locking and will assure a safe, clean cut.

ACCESSORIES:

- 00980 - 132lb/136lb Shear Saw Blades
- 00965 - 115lb Shear Blades

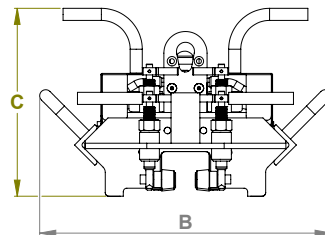
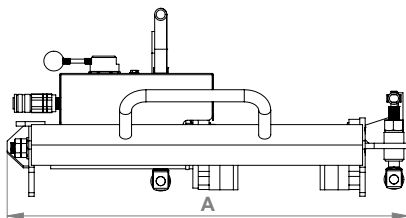

FLOW
5 GPM (19 LPM)

PRESSURE
2000 PSI (140 bar)

DIMENSIONS
A - 27" (68.6cm)
B - 20" (50.8cm)
C - 13" (33cm)

WEIGHT
111 lbs
(50.3 kg)

05100B WELD SHEAR

The Railtech Matweld Weld Shear is light-weight and highly efficient. Spring centered flow control valve permits safe and precise shearing of a thermite weld. The shield totally protects fittings and hoses and the adjustable hold-downs are self locking and will assure a safe, clean cut.

The weld shear is equipped with a factory set adjustable hydraulic flow cartridge to assure the time to fully stroke the shear blades during an actual shear operation is between 16 and 18 seconds.

ACCESSORIES:

- 00980 - 132lb/136lb Shear Saw Blades
- 00965 - 115lb Shear Blades

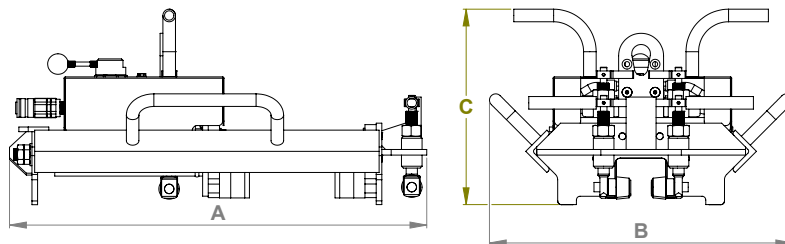

FLOW
5 GPM (19 LPM)
OR
10 GPM (38 LPM)

PRESSURE
2000 PSI (140 bar)

DIMENSIONS
A - 27" (68.6cm)
B - 20" (50.8cm)
C - 13" (33cm)

WEIGHT
85 lbs
(38.6 kg)

05000 HAND PUMP WELD SHEAR

The Railtech Matweld Hand Pump Weld Shear is a self contained Hydraulic Weld Shear. The adjustable hold downs are self locking and will assure a clean safe cut. The average cycle time is 30-45 seconds to shear a weld. The hand pump model can be converted to operate with the Matweld Power Unit with very minor modifications.

ACCESSORIES:

- 00980 - 132lb/136lb Shear Saw Blades
- 00965 - 115lb Shear Blades

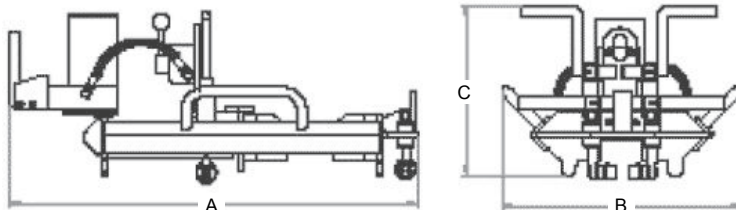

PRESSURE
3000 PSI (206 bar)

DIMENSIONS
A - 29" (73.7cm)
B - 20" (50.8cm)
C - 13" (33cm)

WEIGHT
130 lbs
(59 kg)

RAILTECH

M A T W E L D

Ⓞ DELACHAUX GROUP

DRILLS / IMPACT WRENCHES

03500 SELF-FEED RAIL DRILL

The Railtech Matweld Self Feed Rail Drill is a lightweight maintenance tool that offers cost effective operation. Maintenance crews will appreciate the simple clamp for quick setup on track. The use of Arrowhead inserts (patented), allows for quick drilling time and precision holes. The drill includes a lubrication system.

ACCESSORIES:

- 03532 - Rail templates (Specify Rail Profile)
- 01540 - Index bars (Specify Rail Profile)
- 03598 - Storage Case
- 03599 - Biodegradable cutting fluid (1 or 5 US Gallon)
- Assortment Of Carbide Drill Bit Inserts

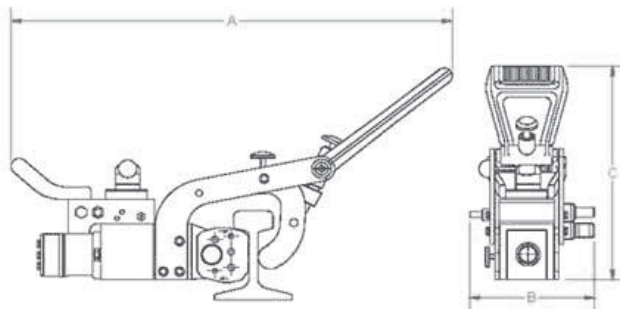

FLOW
10 GPM (38 LPM)

PRESSURE
2000 PSI (140 bar)

DIMENSIONS
A - 35" (89cm)
B - 9" (22.8cm)
C - 15½" (39.4cm)

WEIGHT
68 lbs
(31 kg)

SELF-FEED RAIL DRILL BIT OPTIONS



ARROWHEAD INSERT (PATENTED)

PART NO. DESIGNATES WHICH DIAMETER INSERTS ARE AVAILABLE FOR THAT PARTICULAR HOLDER.

ARROWHEAD INSERT SPECIFICATIONS:

HOLDER PART NO.	INSERT DIAMETERS: ENGLISH	INSERT DIAMETERS: METRIC
03570-1	$\frac{7}{8}$ " , $1\frac{5}{16}$ " , 1"	22mm, 23mm, 24mm, 25mm
03571-1	$1\frac{1}{16}$ " , $1\frac{1}{8}$ " , $1\frac{3}{16}$ " , $1\frac{1}{4}$ " , $1\frac{5}{16}$ " , $1\frac{3}{8}$ "	26mm, 27mm, 28mm, 29mm, 30mm, 31mm, 32mm, 33mm, 34mm, 35mm
03572-1	$1\frac{7}{16}$ " , $1\frac{1}{2}$ " , $1\frac{5}{8}$ "	36mm, 37mm, 38mm

OTHER SPECIAL ORDER BIT SIZES ARE AVAILABLE UPON REQUEST

SELF-FEED RAIL DRILL: RAIL TEMPLATES AND INDEXING BAR OPTIONS

RAIL TEMPLATES:

PART NO.	DESCRIPTION	PART NO.	DESCRIPTION
03532-1	112-115-119 / 131-132-136	03532-15	100 A.R.A.-A.
03532-3	100 AREA - U.P. / 105 DUDLEY	03532-16	22 KG/M
03532-4	133 AREA / 140 AREA	03532-17	30 KG/M
03532-5	127 DUDLEY / 130 PS	03532-18	48 KG/M
03532-6	90 A.R.A.-B	03532-19	57 KG/M
03532-7	90 A.R.A.-A	03532-20	152 PS
03532-8	110 AREA / 110 AREA - U.P.		
03532-9	112-115-119 / 141 AB		
03532-10	100 AREA (2 ⁴⁵ / ₆₄ " TO CENTERLINE OF HOLE)		
03532-11	131-132-136 RE / 133 RE		
03532-12	100 A.R.A.-B		
03532-13	85 A.S.C.E		

DOUBLE SIDED
TEMPLATE



INDEXING BARS:

PART NO.	DESCRIPTION	PART NO.	DESCRIPTION
01540-1	2 ¹ / ₁₆ x 5 ¹ / ₂	01540-10	2 ³ / ₈ x 5 ¹ / ₂
01540-2	2 ¹ / ₂ x 6 ¹ / ₂	01540-11	2 ⁵ / ₁₆ x 6 ¹ / ₂ x 6 ¹ / ₂
01540-3	3 ¹ / ₂ x 6 x 6	01540-12	2 ¹ / ₂ x 6
01540-4	2 ¹³ / ₃₂ x 5 x 5	01540-13	3 x 6 ¹ / ₂ x 6 ¹ / ₂
01540-5	2 ³ / ₄ x 5 ⁵ / ₈ x 5 ⁵ / ₈	01540-14	2 ¹ / ₂ x 5 ¹ / ₂
01540-6	2 ¹ / ₃₂ x 5 x 5	01540-15	2 ¹ / ₂ x 5
01540-7	2 ²³ / ₃₂ x 6 x 7	01540-16	2 x 4 ¹ / ₂
01540-8	2 x 7	01540-17	2 ³ / ₄ x 5.6 x 5.6
01540-9	2 ³ / ₁₆ x 4 ¹ / ₂	01540-18	2 ⁷ / ₁₆ x 6 ¹ / ₂

INDEXING BAR

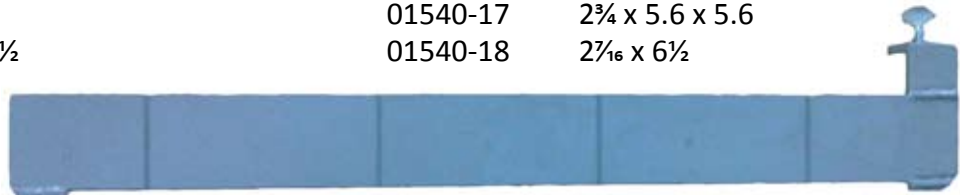

ACCESSORIES:

PART NO.	DESCRIPTION
03598	STORAGE CASE
03599-1	BIODEGRADABLE CUTTING FLUID - 1 GALLON
03599-5	BIODEGRADABLE CUTTING FLUID - 5 GALLONS

01500 RAIL DRILL

The Railtech Matweld Hydraulic Rail Drill is a small, dependable and efficient maintenance tool that offers cost-effective operation under adverse conditions. Simple clamp and height adjustment mechanisms allow quick set-up time on a variety of track configurations. The drill has a quick-set indexing bar that provides accurate hole spacing. Standard flat spade bits are used and can be changed in seconds without the need for wrenches. The rail drill includes a lubrication system.

ACCESSORIES:

Drill Bits	Specify Size
Form Blocks	Specify Size
Index Bars	Specify Size

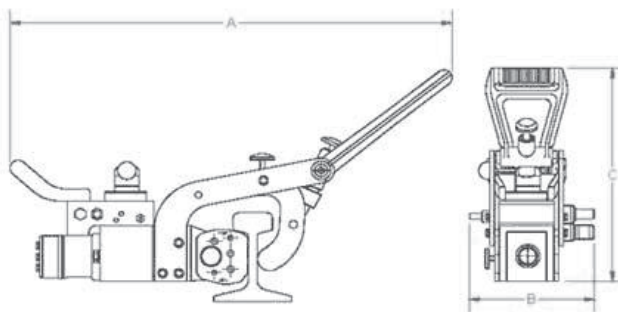

FLOW
5 GPM (19 LPM)

PRESSURE
2000 PSI (140 bar)

DIMENSIONS
A - 35" (89cm)
B - 13" (33cm)
C - 25" (63.5cm)

WEIGHT
63 lbs
(28.6 kg)

01600A

5 GPM 1" IMPACT WRENCH

The 1" Impact wrench is capable of handling the toughest jobs. Crossing, frog or track bolts are no problem for this rugged tool. Optional handles allow the operator to modify the tool to provide an efficient, safe and ergonomic work position for the task at hand. A torque adjustment knob fine-tunes torque from 0-3500 ft/lb. Designed for 5 GPM operation, permits simultaneous use of another 5 GPM tool on the Railtech Matweld dual circuit power unit, maximizing efficiency of a multi-man crew.

ACCESSORIES:

01635 - Stand Up Handle

01669 - Crossing Handle

Sockets Available - Specify Requirements

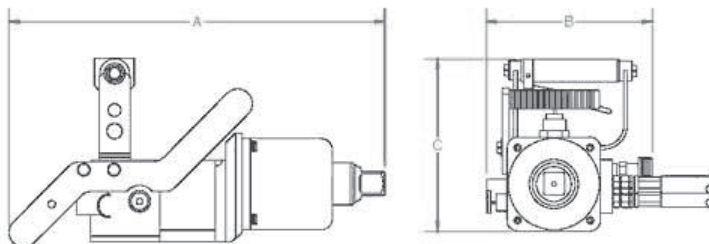

FLOW
5 GPM (19 LPM)

PRESSURE
2000 PSI (140 bar)

DIMENSIONS
A - 17½" (44.5cm)
B - 8" (20.3cm)
C - 9" (22.8cm)

WEIGHT
33 lbs
(15 kg)

01600A 5 GPM 1" IMPACT WRENCH ACCESSORIES

Note: For proper size retaining ring, match number in parentheses of socket ordered with last digit of retaining ring part number.

Other size sockets and retaining rings available upon request.

1005111: Fast Pack front-end impact assembly. Complete, assembled and packed with grease ready to install.

ACCESSORIES:

01635	Stand Up Handle	10000-1	Socket Retaining Ring 2.13" (2 $\frac{1}{8}$) Diameter
01650	Torque Adjustment Gauge	10000-2	Socket Retaining Ring 2.38" (2 $\frac{3}{8}$) Diameter
01665	(3) $\frac{7}{8}$ " Impact Socket	10000-3	Socket Retaining Ring 1.75" (1 $\frac{3}{4}$) Diameter
01667	(1) 1 $\frac{1}{8}$ " Impact Socket	10000-4	Socket Retaining Ring 2.63" (2 $\frac{5}{8}$) Diameter
01669	Crossing Handle		
01670	(1) 1 $\frac{5}{16}$ " Impact Socket		
01677	(2) 1 $\frac{1}{2}$ " Impact Socket		
01680	(2) 1 $\frac{5}{8}$ " Impact Socket		
01685	(2) 1 $\frac{13}{16}$ " Impact Socket		
01686	(2) 1 $\frac{7}{8}$ " Impact Socket		
01690	(2) 2 $\frac{3}{16}$ " Impact Socket		

01669 CROSSING HANDLE



01635 STAND UP HANDLE



02500 10 GPM 1" IMPACT WRENCH

The 1" Impact wrench is capable of handling the toughest jobs. Crossing, frog or track bolts are no problem for this rugged tool. Anti-vibration design and optional handle provide an efficient, safe and ergonomic work position for the task at hand. A torque adjustment knob will fine-tune torque from 0-3500 ft/lb. Designed for 5 GPM or 10 GPM.

ACCESSORIES:

02575 - Stand Up Handle

Sockets Available - Specify Requirements



A



B

C

<p>FLOW 5 GPM (19 LPM) OR 10 GPM (38 LPM)</p>
<p>PRESSURE 2000 PSI (140 bar)</p>
<p>DIMENSIONS A - 18" (45.7cm) B - 8" (20.3cm) C - 10" (25.4m)</p>
<p>WEIGHT 37 lbs (16.8 kg)</p>

04500D 1/2" HYDRAULIC DRILL / IMPACT WRENCH

The Railtech Matweld 1/2" Impact wrench is designed to offer the operator superior torque handling capabilities under the most adverse conditions. Operators will appreciate the light-weight aluminum body and the ergonomic trigger design. The impact is shipped with a 7/16" quick change chuck for a wide variety of bits and accessories. A 1/2" square drive is included for the use of 1/2" impact sockets.

ACCESSORIES:

- 01743 - Counter Bore 1 1/2"
- 01750 - Counter Bore 2 9/16"
- 01751 - Counter Bore 3"
- 01774 - 7/16" x 1/2" Auger Bit
- 01783 - 7/16" x 18 Auger Bit
- 01775 - 1/2" x 12" Auger Bit
- 01782 - 9/16" x 18" Auger Bit
- 01777 - 1 1/16" x 12" Auger Bit
- 01781 - 1 1/16" x 18" Auger Bit
- 01795 - 5/8" x 18" Auger Bit
- 045046 - Adapter 1/2" Square Drive

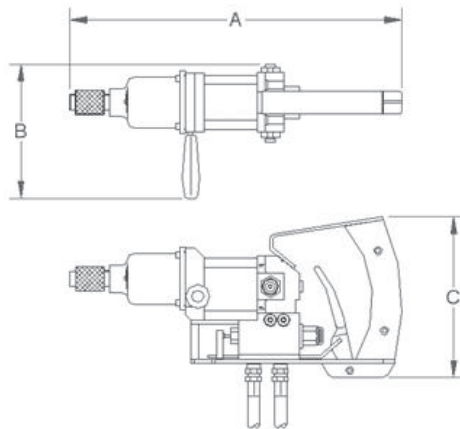
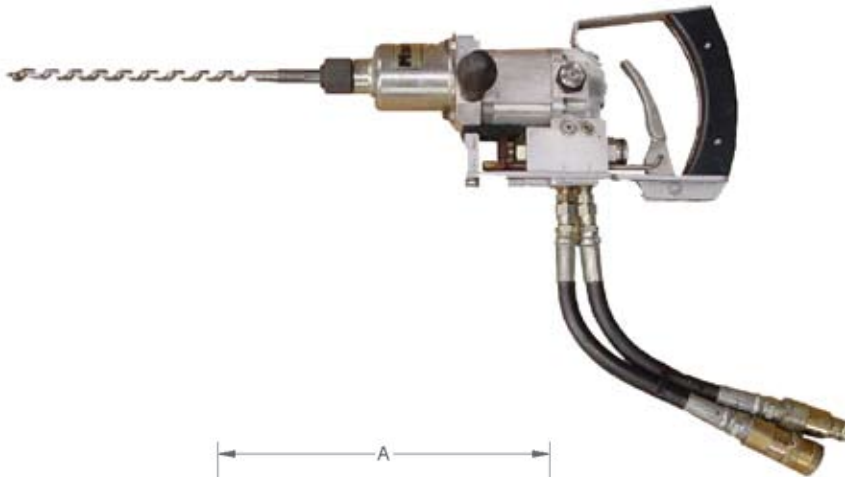

FLOW 5 GPM (19 LPM)
PRESSURE 2000 PSI (140 bar)
DIMENSIONS A - 10" (25.4cm) B - 7" (17.8cm) C - 7" (17.8cm)
WEIGHT 13 lbs (6 kg)

RAILTECH

M A T W E L D

Ⓞ DELACHAUX GROUP

RAIL PULLER / TAMPER / MISC.

03100C RAIL PULLER

The Railtech Matweld 03100C is a hydraulic actuated 120 ton rail puller. Operators will appreciate the single unit construction allowing quick set up time. The operator station houses an integrated intensifier and control valve manifold. Clamping blocks are captured and this self-aligning design is preloaded hydraulically for a safe and efficient pull.

ACCESSORIES:
03101C - Clamping Block



FLOW 5 GPM (19 LPM) OR 10 GPM (38 LPM)
PRESSURE 2000 PSI (140 bar)
Pulling Cylinder Pressure: Rated 5500 PSI (385 bar)
Clamp Cylinder Pressure: Rated 2000 PSI (140 bar)
DIMENSIONS Fully Extended 105" (266.7cm) Fully Closed (storage) 95" (241.3cm) Pulling Cylinder Stroke 10" (25.4cm) Width 34" (86.4cm) Height 17" (43.2cm)
WEIGHT 1350 lbs (612.3 kg)

01100	SINGLE STAGE SPIKE PULLER
01100A	TWO-STAGE SPIKE PULLER
01100AS	SPIKE PULLER w/SAFETY TRIGGER
01100HP	SPIKE PULLER w/HAIR PIN JAWS

The Railtech Matweld Spike Puller is a light-weight powerful maintenance-of-way tool generating 13,000 pounds of pulling force. Safe two-speed design ensures operators grab the spike in a slow speed, avoiding jerking motions common with most spike pullers. The efficient design enables the operator to grab the spike from either side of the rail without repositioning, pull and automatically drop the spike at the top of the stroke in one motion. All moving parts are fully enclosed for safety. The jaws can be changed without special tools in minutes at the work site.

ACCESSORIES:
 01145 - Hair pin puller kit

ALL PULLERS ARE TWO-STAGE UNLESS SPECIFIED TO BE SINGLE-STAGE (MODEL 01100) BY CUSTOMER.

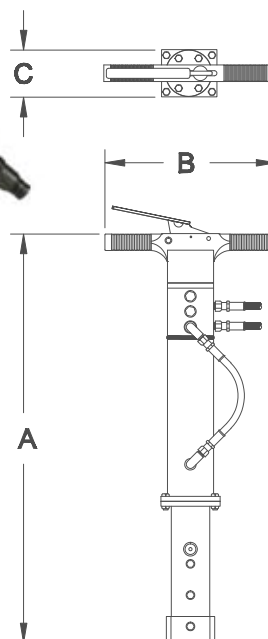

<p>FLOW 5 GPM (19 LPM) OR 10 GPM (38 LPM)</p>
<p>PRESSURE 2000 PSI (140 bar)</p>
<p>DIMENSIONS A - 30" (76.2cm) B - 13" (33cm) C - 4" (10.1cm)</p>
<p>WEIGHT 54 lbs (24.5 kg)</p>

08200 TAMPER

The Railtech Matweld Hydraulic Tamper is equipped with torsion dampened handles which reduce the vibration level to a minimum. An excellent multi-purpose tool that can tamp, cut asphalt or break concrete.

ACCESSORIES:
01362 - Tamper Bit
01365 - Spiker Bit
01370 - Asphalt Cutter Bit
01375 - Concrete Breaker

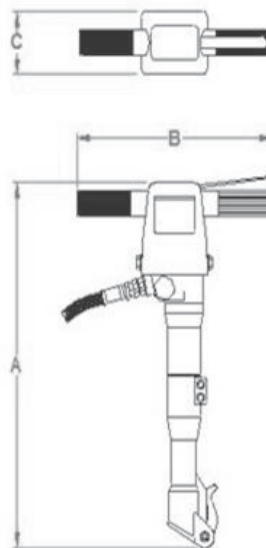

FLOW
5 GPM (19 LPM)

PRESSURE
2000 PSI (140 bar)

DIMENSIONS
A - 18" (45.7cm)
B - 5" (12.7cm)
C - 30" (76.2cm)

WEIGHT
62 lbs (with bit)
(28.1 kg)

08300 SPIKE DRIVER

The Railtech Matweld Spike Driver is equipped with torsion dampened handles which reduce the vibration level to a minimum. An excellent heavy duty tool designed to drive spikes and hairpins into the toughest ties in seconds.

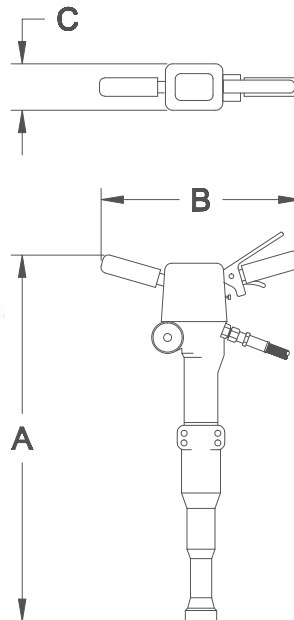

<p>FLOW 5 GPM (19 LPM) OR 10 GPM (38 LPM)</p>
<p>PRESSURE 2000 PSI (140 bar)</p>
<p>DIMENSIONS A - 33" (83.8cm) B - 18" (45.7cm) C - 6" (15.2cm)</p>
<p>WEIGHT 65 lbs (29.5 kg)</p>

02800A 60 TON BRIDGE JACK/SPREADER

The Railtech Matweld Bridge Spreader is the ideal tool for crews doing bridge maintenance. The hydraulic circuit is equipped with a remote power up and down control manifold with built in flow control for protection and comes with a 25 foot transmission hose. Cylinders are pre-piped, terminating at quick disconnect couplers which allow for quick setup time.

ACCESSORIES:
02850 - Jack stand kit



FLOW

5 GPM (19 LPM)

PRESSURE
2000 PSI (140 bar)

DIMENSIONS

A - 194" (492.8cm)
B - 6" (15.2cm)
C - 29" (73.7cm)

WEIGHT

1619 lbs
(734.3 kg)

01200 SPRING ANCHOR APPLICATOR

The Railtech Matweld Spring Anchor Applicator is a lightweight and labor saving tool for the maintenance-of-way crew. A safe and quick method of installing spring anchor clips, which does not require "brute force" for clip installation. The tool utilizes a pivoting foot design with seven tons of force available to install the toughest clips. Operators will appreciate the clear view during installation.

ACCESSORIES:
01225 - Head Worn Rail Kit



FLOW 5 GPM (19 LPM) OR 10 GPM (38 LPM)
PRESSURE 2000 PSI (140 bar)
DIMENSIONS W: 15" (38.1cm) H: 43" (114.3cm)
WEIGHT 48 lbs (21.7 kg)