

Hydrazine Propulsion Module for CubeSats

Derek T. Schmuland
Aerojet
Redmond, WA; 425-869-4546
derek.schmuland@aerojet.com

Robert K. Masse
Aerojet
Redmond, WA; 425-869-4525
robert.masse@aerojet.com

Charles G. Sota
Aerojet
Redmond, WA; 425-869-4511
charles.sota@aerojet.com

ABSTRACT

Cold gas propulsion systems offer today's CubeSats a relatively simple propulsion solution, but with often limited ΔV capability. Various mission and desired CubeSat capabilities have been identified which would be enhanced or enabled if additional ΔV were available in conjunction with preserving the control authority typically associated with current cold gas propulsion systems. These include large scale orbit transfer for constellation deployment, de-orbit, orbit maintenance, attitude control, and momentum management. To expand the overall utility of the CubeSat form-factor with respect to these objectives, Aerojet is developing a 1U blow-down CubeSat Hydrazine Adaptable Monopropellant Propulsion System (CHAMPS) which will deliver a more than five-fold increase in total impulse compared to similarly-packaged cold gas systems. A four-thruster array, providing three-axis attitude control as well as single-axis ΔV , is integrated into a monolithic piston propellant tank doubling as the primary structure. To satisfy varied mission specific propulsion system requirements, the CHAMPS design supports adjustment of the thrust level and minimum impulse via easily changeable fluid resistors and system operating pressure. Thrust vector orientation can also be tailored through simple modifications of the thruster nozzles. The final flight system design will be fully compliant with Air Force Space Command Manual 91-710.

INTRODUCTION

As the result of steadily growing capabilities, CubeSats are becoming increasingly viable for a broad range of missions typically satisfied by larger spacecraft. Aerojet has recently explored the use of the CubeSat form factor for a wide range of applications and has concluded that additional bus power and an increased propulsive capability would be needed to satisfy next generation mission needs. As a result of these findings, Aerojet has chosen to develop and qualify a 1U (10×10×11.3 cm) propulsion system that leverages many of the technologies originally developed for the missile defense programs of the late 1990s and more recently the Missile Defense Agencies Multiple Kill Vehicle (MKV) development program. The Divert and Attitude Control System (DACS) developed for the MKV program is a monopropellant hydrazine system that utilizes propulsion systems technologies that are substantially smaller than those typically employed on

today's spacecraft. Figure 1 is just one example of the component miniaturization progress that has been made in recent years. Presented on the left of the figure is the Aerojet MR-103 hydrazine thruster assembly which is rated at 1 N (0.22 lbf) thrust. To the right is a miniature DACS attitude control thruster assembly, rated for up to 13 N (3 lbf). By leveraging the miniaturization investments made under these programs, it is possible to construct a capabilities-based 1U CubeSat monopropellant propulsion system with the total impulse and minimum impulse bit capability that satisfy a broad range of mission needs from orbit transfer, station-keeping, and momentum management to fine pointing control applications.

It must be recognized that the introduction of a liquid propulsion system onboard a CubeSat adds a level of complexity relative to launch processing, range safety, and mission assurance that has yet to be addressed at

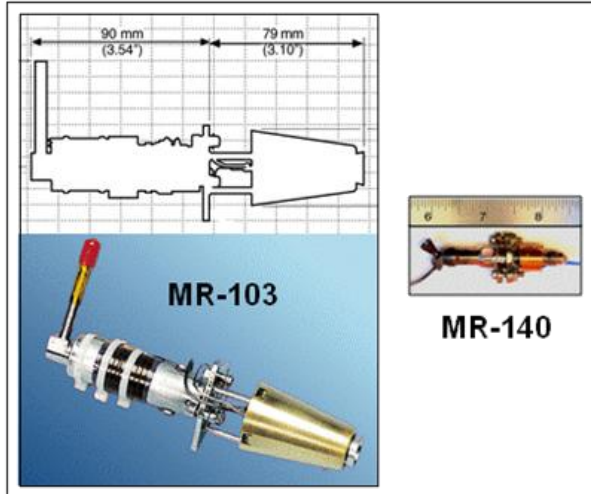

Figure 1: Component Miniaturization Example

this scale, and particularly that the hazards classification associated with the hydrazine propellant will introduce additional handling logistics. However, the performance gains offered by hydrazine are compelling, enabling a much expanded range of potential CubeSat missions.

PROGRAM SUMMARY

Aerojet began developing a 1U hydrazine propulsion system in April of 2011 under Internal Research and Development (IR&D) funding. The system offers a substantial increase in total impulse over existing cold-gas propulsion systems while at the same time providing the needed vehicle control authority. This CubeSat High-impulse Adaptable Monopropellant Propulsion System (CHAMPS) utilizes an array of four proven monopropellant thrusters configured to provide pitch, yaw, and roll attitude control as well as single axis ΔV for orbit transfer and station-keeping applications. At the conclusion of this year's effort, outlined in Figure 2, Aerojet plans to offer a fully-qualified, range safety compliant propulsion system in support of a to-be-determined flight opportunity.

Aerojet has engaged range safety personnel from Vandenberg AFB to assess the CHAMPS design. Discussions thus far have been affirming and constructive, with both organizations collaborating to make progress towards a compliant system. Significant design effort was required to address integration of the necessary inhibits needed to prevent critical hazards from occurring. Given the tight geometric constraints of the 1U CubeSat design, development of a new pressurant isolation valve was required to meet range safety requirements.

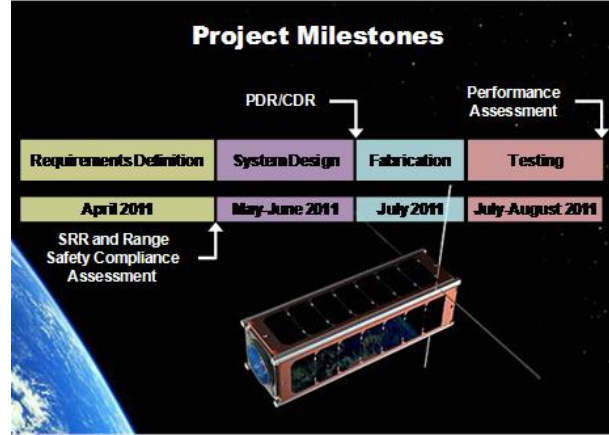

Figure 2: CubeSat Propulsion System Project Schedule

Aerojet is also working with Innoflight Inc. to develop an integrated electronics package that combines the propulsion system valve drive electronics, Attitude and Orbit Control (AODC) and Electrical Power Subsystem (EPS) avionics on a single Circuit Card Assembly (CCA).

SYSTEM DESCRIPTION

Efficient packaging of Aerojet's high-performance CubeSat propulsion system, shown in Figure 3, is accomplished via a pair of CNC machined primary 6Al-4V titanium elements comprising the entire structure, which join to enclose a piston within a cylindrical propellant tank, and into which are also integrated a pressurant gas cavity and all feed system

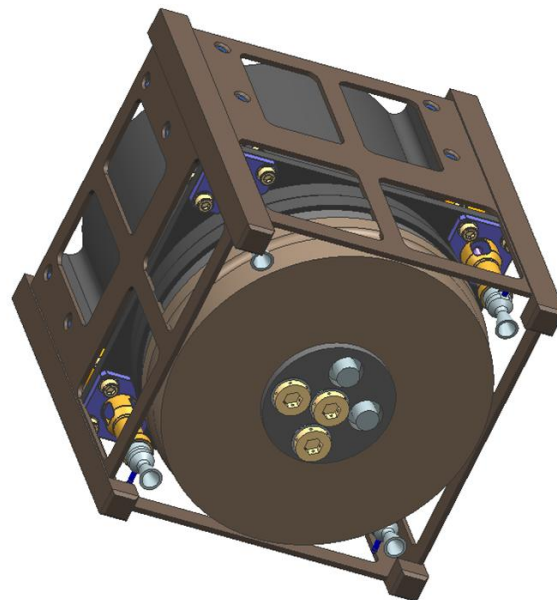

Figure 3: The CHAMPS integrates into a standard 1U frame

components. The vehicle configuration has been optimized to minimize propellant and pressurant manifolds, which are formed exclusively by simple drilling operations on the primary structure. As such, a low system cost is achieved by minimization of required fabrication processes and part count. This highly integrated approach also facilitates consolidation of the propellant, pressurant, and manifolds into a single thermal zone, maintained within the 5-50 °C standard common to most spacecraft in operation today using a single approximately 2W (target maximum) embedded heater. Furthermore, this approach allows the module to readily be axially extended for users requiring more propellant than the baseline 1U configuration delivers. An option to utilize the thruster valve coils as heaters by powering them below the pull-in voltage is also being considered.

Four thrusters mounted one at each corner point through a single face of the cube, canted symmetrically inward from normal (see Figure 4) to provide both ΔV and three axis attitude control with a minimum impingement view factor to any potential deployable structures which may extend from the vehicle in the operational configuration. As it is anticipated that the baseline system would typically be positioned on one end of a 3U CubeSat, a nominal cant angle of five degrees has been selected to favor minimal pointing losses to vehicle total ΔV capability over high control authority about the vehicle minor (roll) axis. Alternate thrust vector schemes can be provided through simple substitution of the thruster nozzle.

A functional schematic of the CHAMPS is presented in Figure 5. A novel two-membrane paraffin-actuated device isolates the pressurization system during system

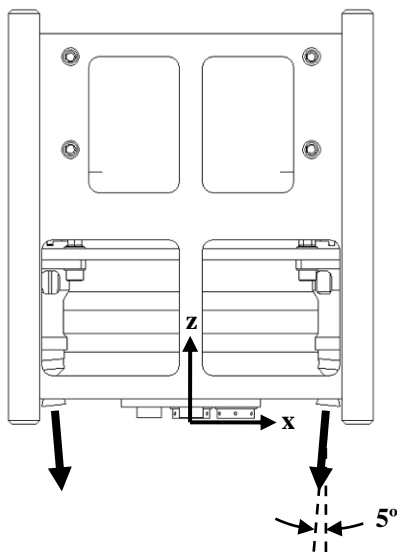

Figure 4: CHAMPS Thrust Vectors

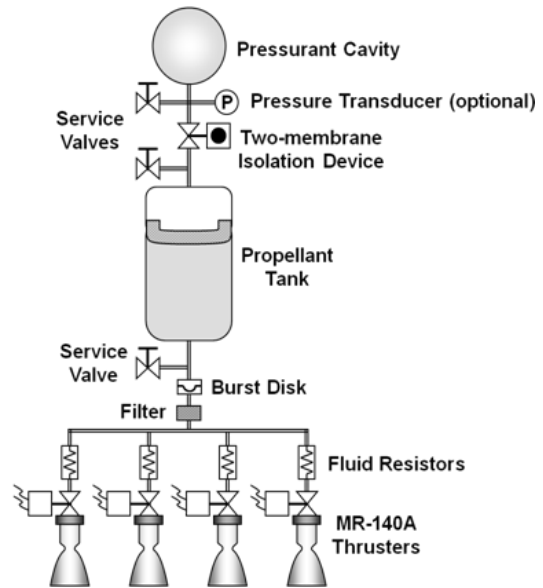

Figure 5: CHAMPS Functional Schematic

processing and launch. The pressurant cavity is sized such that the system will operate in a four-to-one blow-down mode, with a mission customizable system operating pressure of up to a design maximum of 500 psi. The system can also accommodate a gas-side pressure transducer. Three identical dual redundant service valves interface with gas cavities on either side of the pressurant isolation device and the propellant manifold at the tank outlet for leak checking and loading/unloading (if required) of propellant and pressurant, all of which are easily accessible from the thrust egress face of the cube, such that all five other surfaces of the propulsion system are wholly available for solar array mounting and interface with the remainder of the vehicle. Downstream of the piston propellant tank and propellant fill/drain valve, a rupture disk provides hermetic isolation of the remainder of the thruster feed manifold, which is protected from debris generated either by the rupture disk or originating in the propellant tank by a porous metal filter. An interchangeable fluid resistor incorporated into the feed manifold immediately upstream of each thruster valve allows a single thruster configuration to be employed to deliver a mission-tailorable level of thrust.

The MR-140A thruster represents an enabling technology for CubeSats requiring propulsion. Taking advantage of the wide scalability of hydrazine thrusters to be throttled over an unparalleled operating pressure range, the MR-140A draws its heritage to Aerojet's higher thrust MR-140, originally developed for missile defense applications and shown in Figure 6. Through adjustment of the system feed pressure and fluid resistor selection, each of the CHAMPS' thrusters can deliver 0.24 to 2.8 N thrust at beginning of life,

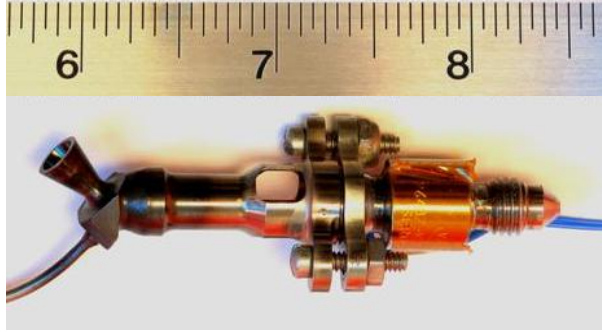

Figure 6: Aerojet MR-140 Thruster

descending to between 0.093 and 0.99 N over the propulsion system 4:1 blow-down ratio. Due to the low propellant throughput and short duration of the majority of anticipated CubeSat missions, and to minimize power requirements, the CHAMPS baseline thruster configuration does not include catalyst bed heaters, which can be added as a future option for systems operating duty cycles that involve many thruster cold starts.

Performance

The approximately one-kilogram (dry) CHAMPS carries 360 g of high-pure hydrazine propellant, providing up to 800 N-sec total impulse. Corresponding predicted ΔV vs. spacecraft wet mass is depicted in Figure 7, alongside performance estimates for three, five, and ten kpsi 1U GN₂ cold gas systems for comparison. While current interest in higher total impulse for CubeSats has primarily focused on the expanded deployment options, increased mission flexibility, and de-orbit capability offered by increased

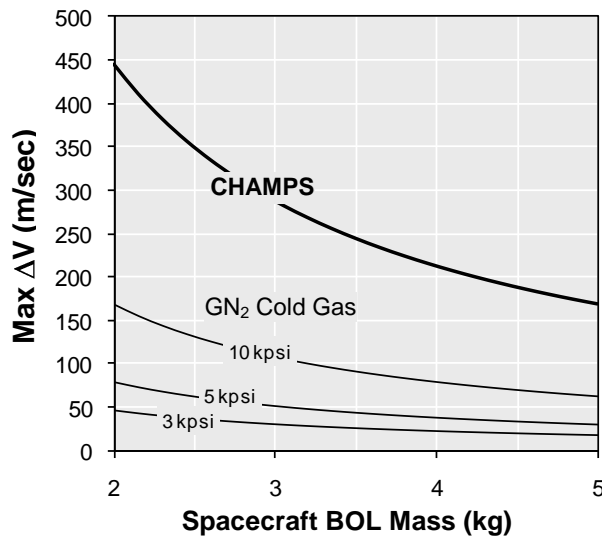

Figure 7: Comparison of maximum deliverable ΔV for CHAMPS and 3, 5, and 10 kpsi 1U GN₂ cold gas systems

ΔV capacity (compared to cold gas), CHAMPS also represents a significantly enhanced attitude control option for CubeSats, either as a primary system or to serve as a backup to, and means to desaturate, momentum wheels. In its nominal configuration, the CHAMPS can fire thrusters in pairs to provide up to 35, 28, and 2.4 N-cm about the respective x, y, and z axes in the maximum thrust configuration. In the minimum thrust configuration, the system can perform extended attitude control for up to several years. Figure 8 reports estimated average propellant consumption rate for the CHAMPS vs. pointing deadband for a 3U, four-kg CubeSat.

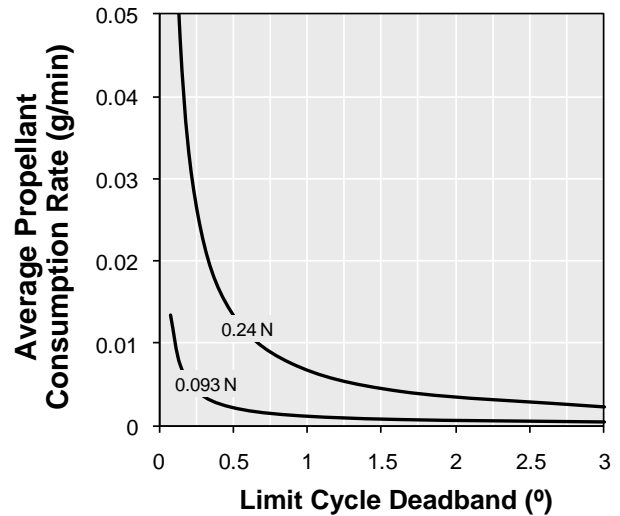

Figure 8: Estimated CHAMPS limit cycle propellant consumption rate at minimum BOL and EOL thrust

Key performance metrics of the CHAMPS are summarized in Table 1.

Table 1: CHAMPS Key Performance Metrics

		Minimum Thrust Configuration		Maximum Thrust Configuration	
		BOL	EOL	BOL	EOL
Thrust (N)		0.24	0.093	2.8	0.99
Torque (N-cm)	x	3.0	1.2	35	12
	y	2.4	0.93	28	10
	z	0.21	0.081	2.4	0.86
Minimum Angular Impulse Bit (N-cm-msec)	x	7.6	2.9	88	31
	y	6.0	2.3	70	25
	z	0.52	0.20	6.1	2.2
Total Impulse (N-s)		760		800	

Controller

CHAMPS will employ highly miniaturized and rad-tolerant control electronics following the Innoflight CubeSat electronics approach packaged within the single 1U propulsion module envelope using a flex circuit card assembly. Control signals from the Command and Data Handling (C&DH) computer and will be routed via a single external harness. At system activation following launch, the controller will activate the system by actuating the paraffin-based pressure isolation device that is used to maintain the propulsion system in an inert state prior to launch. As an important element of the system approach to range safety requirements compliance, the controller will include multiple levels of safety inhibits to preclude unintended actuation. Thereafter, the controller will serve to actuate the MR-140A thruster valves using a variable voltage profile, which provides an approximately 2 ms, 6-8 V pulse for fast open response, but subsequently steps down to a reduced hold-open voltage to both minimize power consumption (< 1W to hold open all thruster valves) and provide the smallest possible minimum impulse bit. This variable voltage drive system also can be used to operate the valve coil as a heater by maintaining the voltage below the pull-in level for the valve. Each valve driver channel will include voltage and current telemetry, along with optional current limiting in order to protect against a shorted valve coil. In addition to the valve channels, the propulsion controller will be able to drive several dedicated heater circuits as well.

The propulsion controller will monitor several dedicated sensors in addition to the voltage and current monitors associated with the valve drivers. These additional sensors will consist of the pressure and temperature transducers displayed in Figure 5. The propulsion controller will provide the data from the sensors to the C&DH computer as required. The propulsion controller will include an FPGA-based processor in order to provide these functions. This processor will have a simple but flexible data interface to the C&DH computer that can be adapted on a mission-specific basis. For example, the processor can act as a node on a Space Plug-and-Play Architecture (SPA) enabled CubeSat, or it can provide data to the C&DH computer through a dedicated point-to-point serial interface. The controller will have extra processing, memory, and Input/Output (IO) resources that can be used to achieve a high level of CubeSat integration. For example, these resources can be used to implement the full CubeSat 3-axis Attitude Control System (ACS) solution. For this type of system, the propulsion controller would provide hardware and software interfaces with the ACS sensors and actuators, and it would run the ACS control algorithms internally.

These more advanced processing capabilities can be disabled for missions with dedicated ACS processors in order to reduce power to the minimum needed for basic propulsion system control.

Following Innoflight's in-house process for reliable advanced space electronics, the propulsion controller will incorporate Commercial Off-The-Shelf (COTS) piece-part technology in order to be compatible with CubeSat cost and volume targets. Piece parts are carefully selected, procured and screened such that they have characteristics making them suitable for use in a Low Earth Orbit (LEO) radiation environment. In addition, the controller will include Innoflight's "Onion Layered" protection features to guard against Single-Event Effects (SEE), including for example memory Error Detection and Correction (EDAC) and multiple levels of watchdog timers. Last, the controller will be designed to handle the power dissipated internally when driving the valves and heaters at the expected duty cycles.

SYSTEM DEVELOPMENT AND QUALIFICATION PLAN

The CHAMPS is being designed to be compliant with the range safety requirements specified in Air Force Space Command Manual 91-710. In addition, the propulsion system transportation, launch, and operational environments used to establish system qualification and acceptance test levels will be selected to envelope, to the greatest extent possible, the various missions and available launch vehicles under consideration to ensure maximum applicability to future needs. To verify the CHAMPS design, Aerojet is planning a series of comprehensive qualification tests. During development of CHAMPS, a series of component level testing will be conducted prior to system integration. This will include pressurization and feed system leak, proof and burst testing in addition to functional testing of the thruster valves. Following system integration, leak and proof testing will be conducted at the integrated system level. Following functional verification of the unit, a series of structural and thermal qualification tests will be performed. The structural testing will include both random vibration and pyrotechnic shock testing.

The thermal vacuum test will be conducted at the system level, including a representative payload, to verify the thermal design and power requirements. During this test, the performance of the thermal management components will be assessed to ensure that the system design is robust enough to survive and operate in the hot and cold extremes. Finally, CHAMPS will be subjected to environmental loads and hot-fired at the system level to verify the delivered

performance satisfies the design objective. Hot-firing testing will include characterization of the maximum throughput capability and total number of pulses possible for the system respectively operating in purely ΔV and attitude control modes.

Once an initial mission is identified for the CHAMPS propulsion system, additional mission specific verification testing will be conducted as required.

CONCLUSION

The CHAMPS propulsion system, scheduled to complete qualification testing this year and be compliant with Air Force Space Command Manual 91-710, is designed to provide a five- fold increase in ΔV as compared to current CubeSat propulsion systems. This added performance will greatly enhance the utility of the CubeSat form factor and expand the type of missions that CubeSats can support. The system will provide three axis attitude control and single axis ΔV .

Aerojet is actively looking for a flight opportunity for this system which can be made available at the end of 2011 following the successfully completion of qualification testing.

ACKNOWLEDGMENTS

The authors would like to acknowledge and thank Kevin Case and John Erickson of the Vandenberg AFB Range Safety group for the invaluable technical assistance they provided the team during this development effort.