

EMI/RFI Shielding Products



Tech-Etch

www.tech-etch.com

EMI/RFI Shielding Products

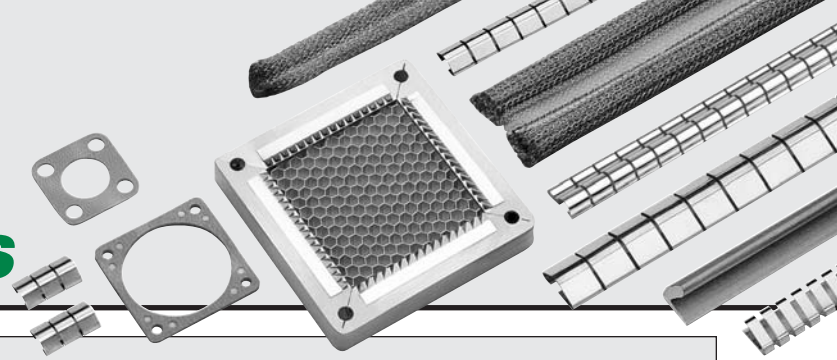

Tech-Etch is a global supplier of EMI/RFI shielding products for the commercial and military markets. A leader in the shielding field for over 40 years, Tech-Etch designs and manufactures both standard catalog and customized shielding products. Our complete line of shielding includes all sizes, shapes, compositions, mounting options and seal types. Products include BeCu shielding strips, conductive elastomers, wire mesh, filters, honeycomb vents, board level, and metalized fabric shielding.

Tech-Etch is dedicated to continued improvement and committed to remaining a leader in the shielding industry. Tech-Etch

has continually introduced new products to maintain our leadership role. Product innovations have included No-snap fingers, Hook-on fingers, Snap-on fingers and more recently DiamondBack shielding. Tech-Etch operates a Quality System that has been registered to **ISO 9001:2000**.

Tech-Etch performs a wide variety of services, and this single-source capability enables us to assume total responsibility for the quality and delivery of our precision products. In-plant services include photoetching, stamping from coil stock and forming from etched blanks, tool and die making, production heat treating, flex-

ible circuit design and production, welding and soldering, metal finishing, plating, and laser cutting. Secondary operations such as soldering joints to seal seams, spot welding, and the application of pressure sensitive tapes and insulation materials are also available.

Tech-Etch supplies many custom designed shielding components for special applications from high volume requirements using progressive dies, to prototype and small quantities utilizing photoetch fabrication. Photoetching economically manufactures custom board level shielding.

Shielding Compatibility

Electromagnetic Compatibility

EMI/RFI Shielding Products are designed to either keep out or keep in electromagnetic interference. Shielding reflects and absorbs incident radiation. The higher the attenuation of the shielding, the more effective it is at keeping in or out the undesired electromagnetic interference.

Electrochemical Compatibility

To avoid galvanic action between contacting metals refer to this chart. Materials in adjacent groups may be safely used together. Choosing materials from within a single group in the table will provide the least corrosion due to galvanic action when the materials are in contact for an extended period of time with appropriate protective finish.

Grouping of Metals by Decreasing Galvanic Activity

Group 1	Group 2	Group 3	Group 4
Magnesium Magnesium Alloys Aluminum Aluminum Alloys Zinc & Zinc Plating Chromium Plating	Aluminum Aluminum Alloys Zinc & Zinc Plating Chromium Plating Cadmium Plating Carbon Steel Iron Nickel & Nickel Plating Tin & Tin Plating Tin/Lead Solder	Cadmium Plating Carbon Steel Iron Nickel & Nickel Plating Tin & Tin Plating Tin/Lead Solder Brass Stainless Steel Beryllium Copper Copper & Copper Alloys Nickel/Copper Alloys Monel	Brass Stainless Steel Beryllium Copper Copper Copper Alloys Nickel/Copper Alloys Monel Silver

Table of Contents

Shielding Strips

Material Specifications and General Information	3
Installation Options (Plastic Rivets, "T" Retaining Caps)	4
How To Order Beryllium Copper Products	6
Part Number Directory	7
Tracks	8
Omni Grounding Series	9
Track Mounting (Symmetrical)	9
Snap-on Mounting (Symmetrical, Variable)	11
Stick-on Mounting (Soft No-snap, SPIDER Low Profile, SPIDER Hook & Stick-on, Low Profile, Hook & Stick-on, No-snap Fingers, Twisted Contacts, Slotless Gaskets)	15
Clip-on Mounting (Perpendicular Contacts, Cylindrical Radius, Strip Gaskets, Reverse Bend Contacts, Twisted Contacts, No-snap & Soft No-snap Fingers)	21
Special Mounting (Reverse Bend Spherical, Reverse Bend, Cylindrical & Spherical Radius, Strip Gaskets)	25
Board Level Shielding	29
Metalized Fabric Gaskets	30

Knitted Mesh Information & Specifications	32
Wire Mesh - Mesh & Elastomer Core - Series 2000	33
Silvershield - Mesh Core - Series 2200	35
Twinsel - EMI & Environmental Seal - Series 3000	36
Connector & Waveguide Gaskets - Standard Products	37
Custom Gaskets - Metal & Metalized Fabric	39
Thin Sheet and Strip Materials	
Supershield - Conductive Elastomer - Series 1000	40
Multishield - Oriented Wire in Elastomer - Series 4000	42
Monoshield - Monel or Aluminum & Elastomer - Series 5000	44
Weaveshield - Aluminum Mesh & Elastomer - Series 5500	45
Trimshield Mesh On Aluminum Frame - Series 9000	46
Shielded Vents & Filters	
Vent & Filter Specifications	47
Honeycomb Shielded Vents - Series 8000	48
Shielded Fan Vents - Series 8200	49
Quiet Vents - Honeycomb - Series 8300	50
Aluminum Mesh Electronic Filters & Thin Screen Shielded Filters - Series 8500 & 8900	51

The data presented in this catalog is based on testing and to our knowledge is accurate and true. Since applications, test methods and test procedures may vary, we recommend that users of our products perform their own tests to assure the suitability of these products for their specific applications. We offer no product warranty, either expressed or implied, except any product proven defective will be replaced. Freedom from present or future patent infringement cannot be guaranteed, nor can the suitability of our products for specific applications.

Shielding Strips

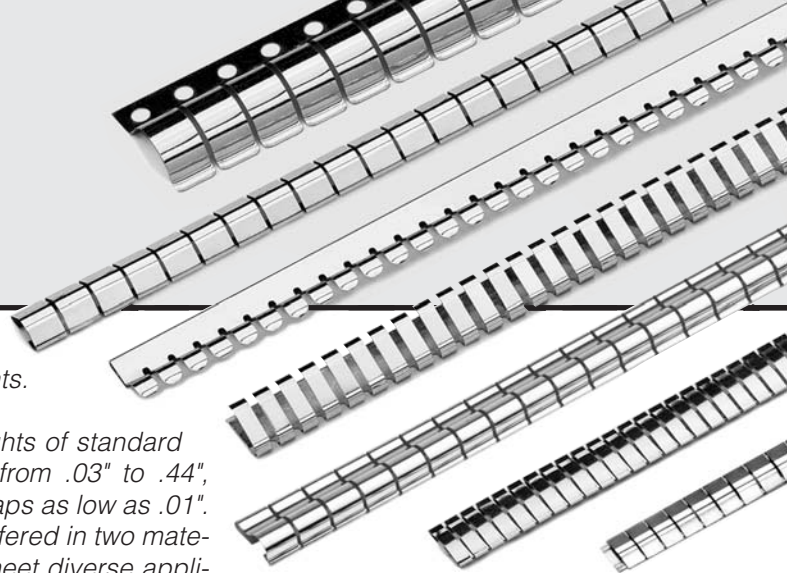

Tech-Etch offers the most complete line of standard BeCu shielding strips in the industry. Shielding strips are designed for a wide variety of application requirements. They are available in strips ranging from 16 to 24 inches in length, in continuous coils up to 35 feet long, as single fingers, or cut to requested full-finger lengths. Consult our engineering department for special modifications to

suit your requirements.

Uncompressed heights of standard finger stock range from .03" to .44", which will occupy gaps as low as .01". Many gaskets are offered in two material thicknesses to meet diverse application compression requirements: "Standard" and "TF", which requires less

force to compress the gasket to its operating range.

Beryllium Copper

Beryllium Copper (BeCu) is a high performance metal which can be fabricated into a wide variety of components. Its mechanical and electrical properties make it the ideal material for EMI/RFI shielding products.

Beryllium copper's electrical properties provide shielding effectiveness over an extremely broad frequency range. At the same time, its mechanical properties yield a high deflection range, in addition to a long life

without compression set. BeCu finger stock provides maximum spring properties for strength and fatigue resistance, plus excellent conductivity. Available in many plating options, BeCu has a high cycle time and conforms to large gap variations making it the best material for attenuation.

DiamondBack (dB)

DiamondBack shielding with a textured contact surface increases attenuation at 2.5 GHz and above. Nonabrasive DiamondBack

texturing can be applied to most of the standard profiles to achieve up to a 20 dB attenuation improvement at high frequencies without raising the compression force. It has hundreds of raised dimples providing a smooth texture that enhances the conductivity between the gasket and mating surface. DiamondBack is available on numerous mounting and finish options, and offers superior longevity over plated fabrics.

Stainless Steel

Stainless steel is an economical alternative to beryllium copper for shielding applications where high attenuation is not required. It does not have the electrical conductivity of

BeCu and is stiffer. Mechanical considerations generally limit the use of stainless steel to low profile strips and twisted contacts. Items are identified by  in the notes.

Attenuation

For maximum attenuation of a gasketed gap, the contact resistance of the mounting joint and closing joint must be very low and remain so throughout the life of the product. While a gasket may have the potential for very high attenuation under ideal conditions, over time oxidation, corrosion and dirt

at the mounting and closing joints may reduce effectiveness. Factors influencing contact resistance over the life of the product are pressure (closing force), plating, and wiping action. Our engineers can help you determine the optimal specifications to ensure sustained attenuation.

Compression

The purpose of shielding is to occupy and thereby shield the gap that exists between two adjoining surfaces. In order to be effective, shielding gaskets must be able to occupy both the maximum and minimum gaps, which exist due to fabrication tolerances, misalignment of surfaces, or irregular surfaces. Proper compression management is essential to ensure effective EMI shielding. Tech-Etch will be pleased to assist you in specifying the most effective gasket for your requirements.

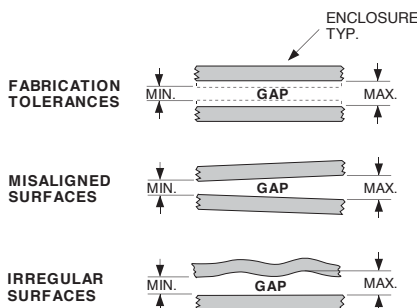

OPERATING RANGE = MAX. GAP - MIN. GAP

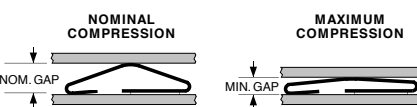
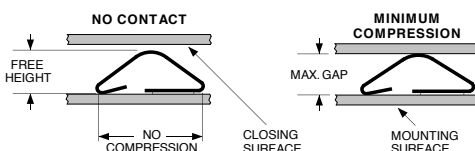

Materials

Beryllium Copper (BeCu) ASTM B194 Material Specifications

Chemical Composition

Beryllium	1.80-2.00%
Cobalt plus nickel	0.20% Min.
Cobalt + nickel + iron	0.6% Max.
Copper	Balance

Physical Properties (heat treated)

Electrical conductivity (% IACS)	22-25
Modulus of elasticity (psi)	18.5 x 10 ⁶

Mechanical Properties (heat treated)

Temper (1,000 psi)	¼ HT	½ HT
Tensile strength	175 Min.	185 Min.
Yield strength	.2% offset	
	150 Min.	160 Min.

Stainless Steel Material Specifications

Type 301 Stainless steel possesses good heat and corrosion resistance.

AISI 301 Analysis

C:	.15 Max.
Mn:	2.00 Max.
Si:	.750 Max.
P:	.040 Max.
S:	.030 Max.
Cr:	16.00/18.00
Ni:	6.00/8.00

Shielding Strips Installation Options



Shielding strips are designed for a wide variety of application requirements, and can be supplied cut to length or full size in any of the following mounting configurations. Consult our engineering department for special modifications to suit your requirements.

If you know the Shielding Strip Part Number you are looking for, see the directory on page 7.

Clip-on Mounting



Clip-on Mounting provides a reliable mechanical installation when there is an accessible mounting flange. Various flange thicknesses can be accommodated, and lances can be added to enhance the holding force to the flange.

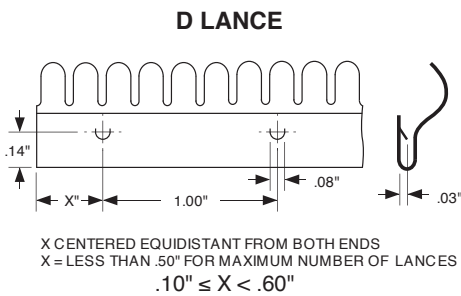

Certain Clip-on strips have lance locations other than shown above. These dimensions are specified on the product drawings in the Clip-on section.

Extrusion Mounting

Tech-Etch "S" Series symmetrical shielding strips can be installed on extrusions specially designed to provide a useful free height. A durable shielding solution for applications requiring bi-directional motion. The drawing below illustrates guidelines for designing the extrusion.

Dimension "A" less allowance for initial contact is the compression range. Dimension "B" should be approximately .020" less than the open dimension of the shielding strip.



Stick-on Mounting



Pressure Sensitive Mounting provides double-sided pressure sensitive transfer tape for a fast, reliable installation. 3M F9469PC transfer tape or equivalent may be used at ambient temperatures from -67°F to 300°F. Apply only on a clean, oil-free surface, and allow a 24-hour cure time. Consult the factory for other adhesives and extended liner options.

STICK-ON GASKET



HOOK & STICK-ON GASKET

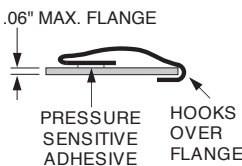

Hook and stick fingers are ideal for flange mounting applications requiring low compression forces and small gap shielding.

Non-conductive .010" thick adhesive may be specified for improved adhesion on rough surfaces. Conductive adhesives and extended liners are also available. Consult the factory for these options.

Special Mounting

Special Mounting shielding strips can be installed by spot welding or soldering. Rivets can be used for the 375A and 500A profiles and conductive pressure sensitive adhesives are available. Consult the factory.

Snap-on Mounting



Slot and Edge Mount Symmetrical fingers using single or double fingers are very economical for applications such as sliding drawers, doors, rack-mounted assemblies and covers. They perform well in bi-directional applications and the snap-on capability makes them easy to install.

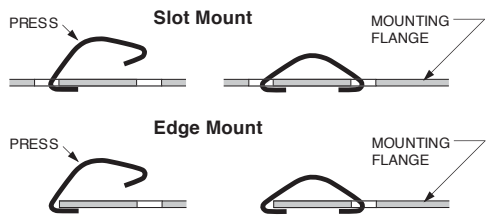

When continuous shielding is required the V Series or VE Series utilizing the same snap on mounting feature can be used. The figure below illustrates available repeating finger patterns for the V and VE Series.

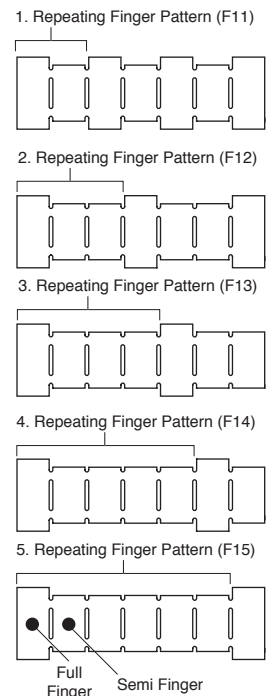

Consult factory for the availability of other patterns.

Track Installation Options & Accessories



Track / Extrusion Mounting

Track or extrusion mounted symmetrical fingers provide a durable shielding solution for applications requiring bi-directional motion, such as drawers and plug-in modules.

TR Series Track is typically installed with plastic rivets, but is also available with pressure sensitive tape for adhesive mounting. The track can be installed prior to the assembly of the finger strips to avoid damaging the fingers. See below. Photos at right illustrate several methods of retention, including "T" Retaining Caps. Retention stops can also be incorporated in the sheet metal.

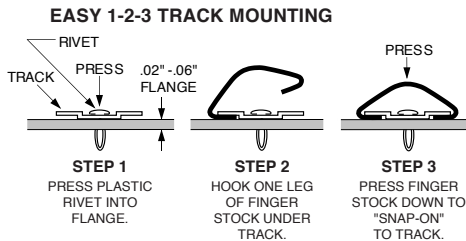

Plastic Rivets

Plastic rivets can be used to install Track and as rivet stops to retain shielding on a track as shown below and in the photo on the right. When used on a flange, the hole diameter for the rivet should be .125". Two rivets are available: PR45 and PR60 (See Track Accessories below.).

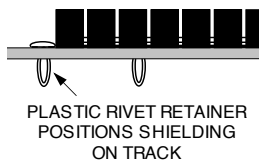

"T" Retaining Caps

"T" Retaining Caps (See Track Accessories below) can also be used to hold shielding on the Track as illustrated here.

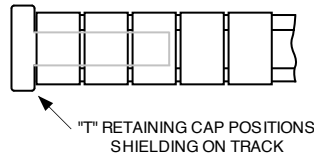

Track in the top photo shows two shielding retainer options: Plastic Rivet Stop on the left and "T" Retainer on the right. Bottom photo shows the same track with shielding snapped into place.

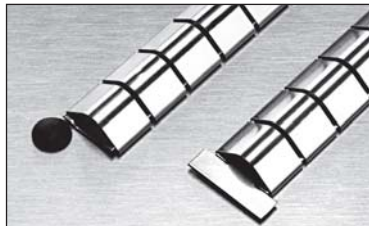
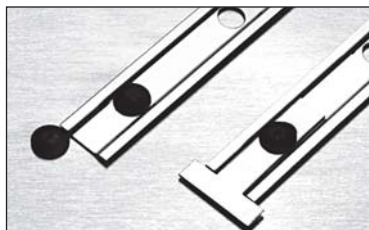

Pressure Sensitive Transfer Tape Mounting



Perhaps the easiest track mounting option is with double sided pressure sensitive transfer tape. Simply apply on a clean, oil-free surface, and allow a 24-hour cure time.

Omni Track

Omni Track is designed to provide a track type mounting for single finger applications. It is typically supplied with pressure sensitive tape for adhesive mounting. Holes are available for rivet mounting.

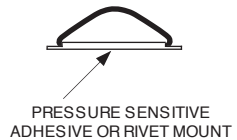

Track Accessories

PR45 PLASTIC RIVET

Used on Snap-on Track and OMNI Mounting Pads.
Panel Hole Dia. .123" - .127"
Panel Thickness .02" - .06"
Order PR45 Rivets, if required for your application.

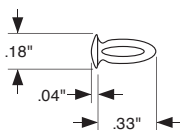

PR60 PLASTIC RIVET

Used on Snap-on Track and OMNI Mounting Pads.
Panel Hole Dia. .118" - .125"
Panel Thickness .045" - .075"
Order PR60 Rivets, if required for your application.

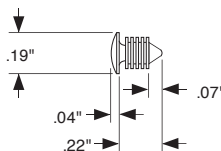

TCXX "T" RETAINING CAPS

"T" Retaining Caps are used at the ends of Mounting Track to hold finger stock in place.
Material: Brass.
Finish: Bright.

"T" CAP	"A"	"B"
TC37	.45"	.16"
TC60	.70"	.26"
TC80	1.00"	.35"

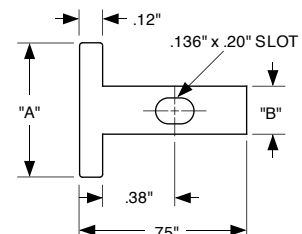

How To Order Shielding Strips

Tech-Etch Part Numbers are unique because they describe the actual part. This makes it easy to order and also to understand the specifications of any strip. The chart below explains how to read and create Part Numbers.

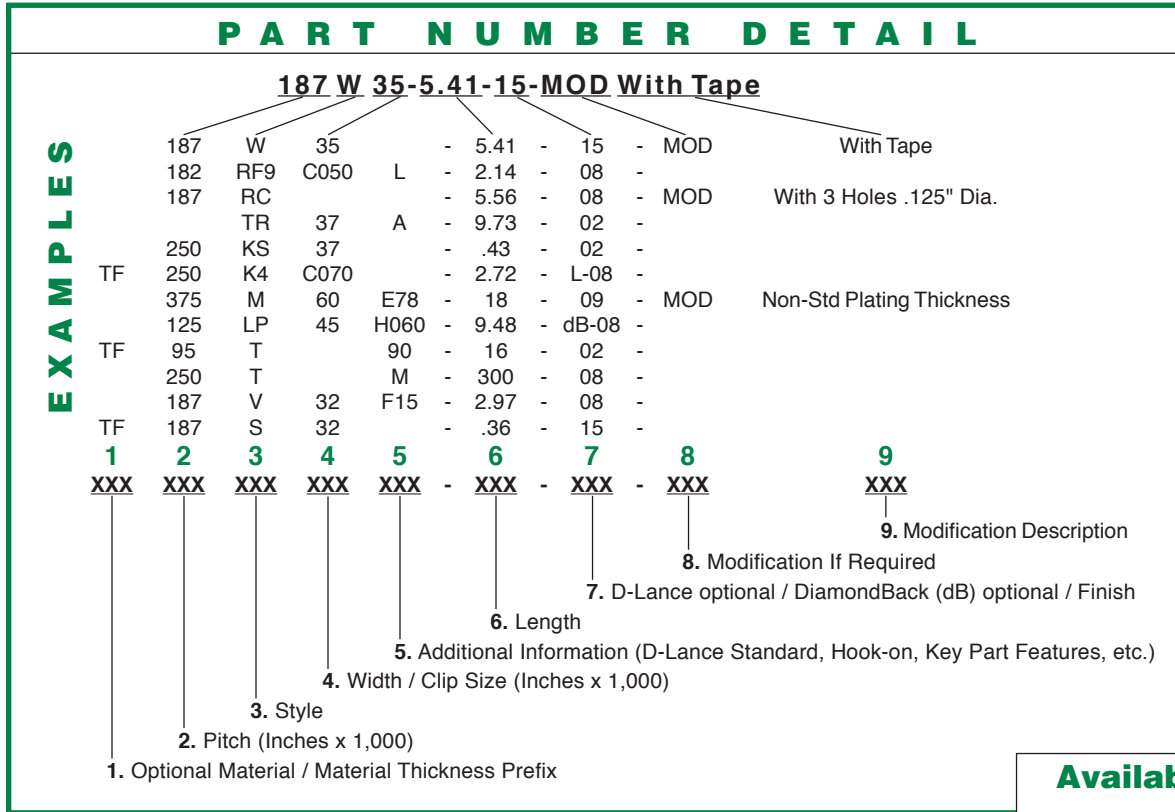

Available Finishes

Finish*	Ordering Code
Solderable	01
Clean and Bright	02
Gold	03
Silver	04
Cadmium/Clear Chromate	05
Tin Lead	07
Bright Tin	08
Nickel	09
Zinc/Clear Chromate	15
Electroless Nickel	18
Other	00

* For other requirements and specifications of these finishes, consult the factory.

- 1. Optional Material / Material Thickness Prefix:** Leave blank for standard thickness. Add "TF" for low compression force. "SS" indicates Stainless Steel.
- 2. Pitch:** Center-to-center distance from one finger to the next (Inches x 1,000).
- 3. Style:** Part Style or Series.
- 4. Width:** Part Width, typically measured parallel to fingers and slots.
Clip Size: "CXXX"=Clip Size, where XXX is typically flange size +.010".
- 5. Additional Information:** "L"=Standard D-Lance; "H060"=Hook-on; "90"=90° Bend; "R" and "A, B, C, T"=Track features; "E50, E78"=Extended Leg; "M"=Clip-on Feature; "FXx"=Determines Repeating Finger Pattern for Variable Snap-on (See page 4.)
- 6. Length:** Full Strips=Length to nearest inch as listed in catalog (24, 18, 16, etc.).
Length: Rolls=Length to nearest inch as listed in catalog (300, 420, etc.). Also add "M" to Additional Information for all T-Series rolls. (See column 5.)
Length: All Cut-to-Length Parts= Length to 2 decimals: (.XX)=(Pitch) x (Number of Fingers) minus (one slot dimension). Since individual fingers may not be cut, length is a multiple of a full finger (the Pitch), less the slot dimension. Exceptions are 95A, 95T, 165T, 165T2, 250T, 500T and KS Series, where cut-to-length parts are to 2 decimals and: (.XX)=(Pitch) x (Number of Fingers).
- 7. D-Lance:** "L-" for optional, non-standard D-Lance. **DiamondBack:** Optional DiamondBack texturing "dB"
Finish: See table for available finishes.
- 8. Modification If Required:** Add "MOD" for all modified parts. A description of the modification is also required.
- 9. Modification Description:** Specific description of the modification. For example: With 2 Holes .100 Dia., With Conductive Tape, Less Tape, Special Width, Non-Standard Tolerances, Non-standard Material Thickness, Non-standard Plating Thickness, Special Packaging, etc.

Part Number Directory



How to Order Shielding Samples: The easiest way to order samples is to visit our Free Sample page on our web site. Of course you can also call and supply part numbers, quantities and other appropriate application information.

Part Number	Page	Part Number	Page
60D Reverse Bend Contacts	25	187S30 Symmetrical Finger Stock (up to 4 fingers).....	12
60P21 Soft No-slag Fingers	16	187S32 Symmetrical Finger Stock (up to 4 fingers).....	11
60R Spherical Radius Finger Stock	27	187AS32 Alternate Slot Symmetrical Finger Stock (up to 18" long) ...	10
60RC Reverse Bend Spherical Finger Stock	25	187S32 Symmetrical Finger Stock (up to 18" long).....	10
75RC Reverse Bend Spherical Finger Stock	25	187V32FXx Variable Snap-on Gasket	11
75RE Spherical Radius Finger Stock	27	187VE32FXx Variable Edge Mount Snap-on Gasket	12
75RF Spherical Radius Finger Stock	27	187W35 Soft No-slag Fingers	15
93AS32 Alternate Slot Symmetrical Finger Stock (up to 18" long) ..	10	206W36 Soft No-slag Fingers	14
93R1D Reverse Bend Spherical Finger Stock	25	219S60 Symmetrical Finger Stock (up to 4 fingers).....	13
93S32 Symmetrical Finger Stock (up to 18" long).....	09	219S60 Symmetrical Finger Stock (up to 18" long).....	10
95A Twisted Contacts	19	250C040 Clip-on Low Profile Finger Stock	21
95T Twisted Contacts	19	250K2C070L Reverse Bend Contacts	23
95T90° Twisted Contacts	19	250K4C070 Perpendicular Contacts	21
95TCXXM Twisted Contacts	24	250KC070L Reverse Bend Contacts	23
95TCXXX Twisted Contacts	23	250KS37 OMNI Single Contact.....	09
125G28 Low Profile Finger Stock	15	250KS60 OMNI Single Contact.....	09
125G32 Low Profile Finger Stock	15	250M37 No-slag Fingers	18
125LP45 Low Profile Finger Stock	15	250M42CXXX No-slag Fingers	24
125LP45H060 Hook & Stick-on Low Profile Finger Stock	16	250P37 Soft No-slag Fingers	17
125LP55 Low Profile Finger Stock	16	250P37E50 Soft No-slag Fingers	17
125LP55C070 Clip-on Low Profile Finger Stock	21	250S37 Symmetrical Finger Stock (up to 4 fingers).....	12
125LP55H060 Hook & Stick-on Low Profile Finger Stock	16	250S37 Symmetrical Finger Stock (up to 18" long).....	10
125LP60 Low Profile Finger Stock	16	250S60 Symmetrical Finger Stock (up to 4 fingers).....	13
125LP60H060 Hook & Stick-on Low Profile Finger Stock	16	250S60 Symmetrical Finger Stock (up to 18" long).....	10
125LP75C070 Clip-on Low Profile Finger Stock	21	250T Twisted Contacts	20
125LPS35 SPIDER Low Profile No-slag Finger Stock	15	250V37FXx Variable Snap-on Gasket	12
125LPS45H060 SPIDER Hook & Stick-on Low Profile Finger Stock ...	15	250VE37FXx Variable Edge Mount Snap-on Gasket	13
125M37 No-slag Fingers.....	18	282V60FXx Variable Snap-on Gasket	14
125M42CXXX No-slag Fingers	25	375A Strip Gaskets	28
127A Reverse Bend Contacts.....	25	375B Cylindrical Radius Finger Stock	28
134B Reverse Bend Contacts.....	26	375CXXX Strip Gaskets.....	22
134C Reverse Bend Contacts	26	375KS80 OMNI Single Contact.....	09
134D Reverse Bend Contacts	26	375M60 No-slag Fingers	18
145A Reverse Bend Contacts.....	26	375M60E78 No-slag Fingers	18
156M32 No-slag Fingers	18	375P60 Soft No-slag Fingers	17
157S20 Symmetrical Finger Stock (up to 18" long).....	09	375P64C070 Soft No-slag Fingers	24
165T Twisted Contacts	19	375P80 Soft No-slag Fingers	18
165T2 Twisted Contacts	20	375S60 Symmetrical Finger Stock (up to 4 fingers).....	13
165T90° Twisted Contacts	19	375S60 Symmetrical Finger Stock (up to 15.75" long)	11
165TC070 Twisted Contacts	23	375S80 Symmetrical Finger Stock (up to 4 fingers).....	14
165TCXXM Twisted Contacts	23	375S80 Symmetrical Finger Stock (up to 15.75" long)	11
165TW.300 Twisted Contacts	19	500A Strip Gaskets	28
182RF8CXXXL Cylindrical Radius Finger Stock.....	22	500P110 Soft No-slag Fingers	18
182RF9CXXXL Cylindrical Radius Finger Stock.....	22	500T Twisted Contacts	20
187H Reverse Bend Contacts	26	LP45 Slotless Gasket	20
187KC080 Reverse Bend Contacts	23	LP60 Slotless Gasket	20
187M32 No-slag Fingers.....	18	SS95T Stainless Steel Stick-on Twisted Contacts	19
187M60 No-slag Fingers.....	18	SS95T90° Stainless Steel Stick-on Twisted Contacts	19
187P21 Soft No-slag Fingers	17	SS125LP45 Stainless Steel Low Profile Stick-on Gasket	15
187P28 Soft No-slag Fingers	17	SS125LP45H060 Stainless Steel Hook & Stick-on Low Profile	16
187P32 Soft No-slag Fingers	17	SS125LP60 Stainless Steel Low Profile Gasket	16
187R _A Cylindrical Radius Finger Stock	28	SS125LP60H060 Stainless Steel Hook & Stick-on Low Profile	16
187R _A Cylindrical Radius Finger Stock	28	SS165T Stainless Steel Stick-on Twisted Contacts	19
187R _B Cylindrical Radius Finger Stock	27	SS165T90° Stainless Steel Stick-on Twisted Contacts	19
187R _{B1} Spherical Radius Finger Stock	27	SS182RF9CXXXL Stainless Steel Cylindrical Radius Finger Stock	22
187RC Cylindrical Radius Finger Stock	27	SS187P21 Soft No-slag Fingers	17
187RD Reverse Bend Contacts	26	SS250C040 Stainless Steel Low Profile Clip-on Gasket	20
187RD2 Reverse Bend Contacts	25	SS275EXS-2 Expansion Slot Gasket.....	20
187RF1CXXX Cylindrical Radius Finger Stock	22	TR32 Mounting Track	08
187RF2CXXX Cylindrical Radius Finger Stock	21	TR37X Mounting Track	08
187RF3CXXX Cylindrical Radius Finger Stock	22	TR60X Mounting Track	08
187RF4C070 Cylindrical Radius Finger Stock	22	TR80X Mounting Track	08
187RGCXXX Cylindrical Radius Finger Stock	21	Accessories:	
187RJ Cylindrical Radius	28	PR45 & PR60 Rivets & TCXX "T" Retaining Caps	05

Note: "TF" Style part numbers are not shown here. See the corresponding standard series part number for page number.



TR32

TRACK

Material: Stainless Steel.

Notes:

For use with Symmetrical Finger Stock 93S32, 93AS32, 187S32, 187AS32, TF187S32, TF187AS32. See page 5 for rivets if required. Recommended flange mounting hole .125" Diameter.

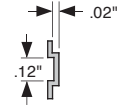
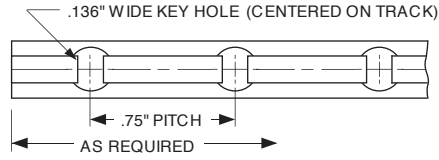

	FEATURE
TR32 T	With Tape

TR37X

TRACK

Material: Brass.
 Finish: Bright.

Notes:

For use with Symmetrical Finger Stock 250S37. See page 5 for rivets and end stops if required. Recommended flange mounting hole .125" Diameter. Also available with double adhesive transfer tape.

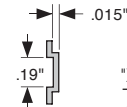
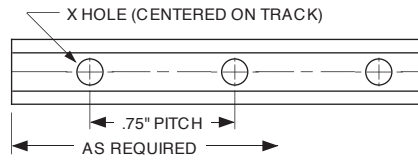

"X"	FEATURE
A	.125" Dia. Holes
B	.136" Dia. Holes
C	.140" x .200" Slots
T	With Tape

TR60X

TRACK

Material: Brass.
 Finish: Bright.

Notes:

For use with Symmetrical Finger Stock 219S60, 250S60, 375S60. See page 5 for rivets if required. Recommended flange mounting hole .125" Diameter.

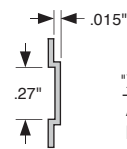
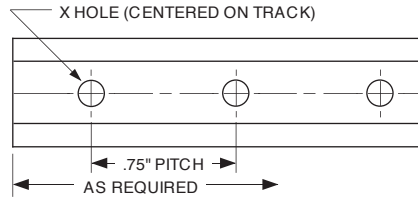

"X"	FEATURE
A	.125" Dia. Holes
B	.136" Dia. Holes
C	.140" x .200" Slots
T	With Tape

TR80X

TRACK

Material: Brass.
 Finish: Bright.

Notes:

For use with Symmetrical Finger Stock 375S80. See page 5 for rivets if required. Recommended flange mounting hole .125" Diameter.

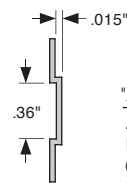
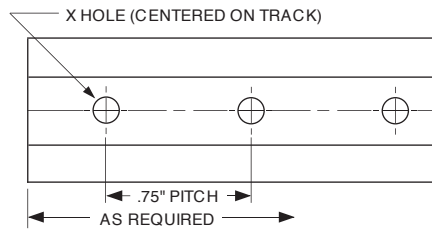

"X"	FEATURE
A	.125" Dia. Holes
B	.136" Dia. Holes
C	.140" x .200" Slots
T	With Tape

Omni Track

- SEE PAGE 6 FOR HOW TO ORDER
- SEE PAGE 7 FOR SAMPLE REQUEST



250KS37

OMNI

Compression Force - Single Contact

	25% Compression (0.098")	50% Compression (0.065")
Standard	.2 lbs	.4 lbs

Mounting Pad Material: Brass. Finish: Bright.
Other finishes are also available.

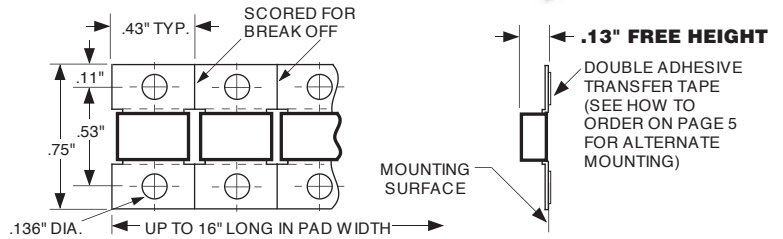

250KS60

OMNI

Compression Force - Single Contact

	25% Compression (0.165")	50% Compression (0.110")
Standard	.05 lbs	.20 lbs

Mounting Pad Material: Brass. Finish: Bright.
Other finishes are also available.

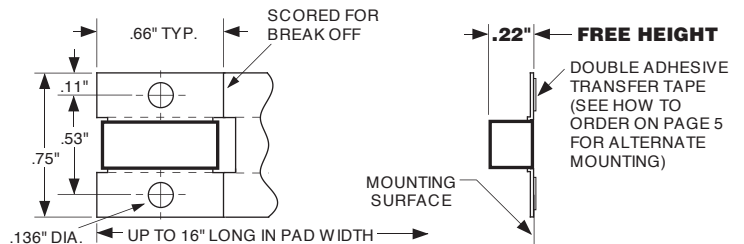

375KS80

OMNI

Compression Force - Single Contact

	25% Compression (0.240")	50% Compression (0.160")
Standard	.5 lbs	2.0 lbs

Mounting Pad Material: Brass. Finish: Bright.
Other finishes are also available.

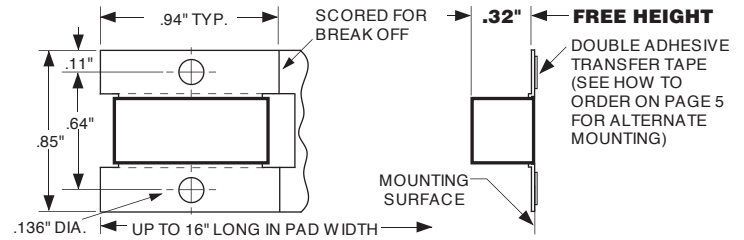

Track Mounting

- SEE PAGE 6 FOR HOW TO ORDER
- SEE PAGE 7 FOR SAMPLE REQUEST

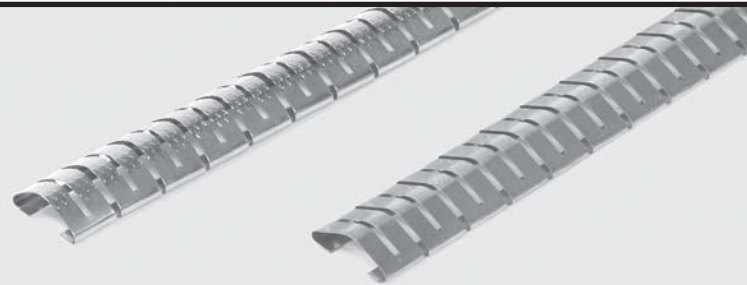

157S20

SYMMETRICAL

Compression Force

	25% Compression (0.056")	50% Compression (0.038")
Standard .002" Thk.	*	*

Note: For use on customer extrusions.
* Consult factory for performance data.

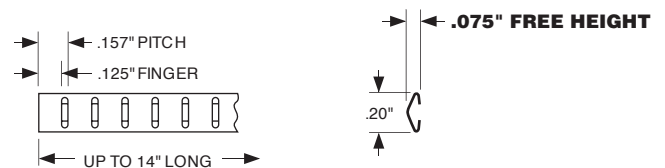

Consult factory for the availability of longer lengths.

93S32

SYMMETRICAL

Compression Force

	25% Compression (0.075")	50% Compression (0.050")
Standard .002" Thk.	9.1 lbs/ft	18.1 lbs/ft

Note: For use with Track TR32, TR32T, STR32XXX, STR32TXXX.

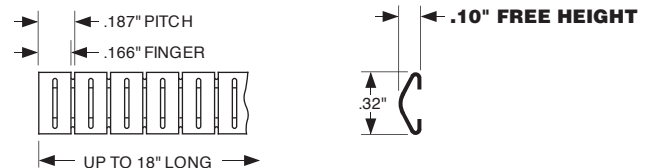

Consult factory for the availability of longer lengths.

Track Mounting

- SEE PAGE 6 FOR HOW TO ORDER
- SEE PAGE 7 FOR SAMPLE REQUEST

93AS32

SYMMETRICAL ALTERNATE SLOT

Compression Force

	25% Compression (0.075")	50% Compression (0.050")
Standard .002" Thk.	9.1 lbs/ft	18.1 lbs/ft

Note: For use with Track TR32, TR32T, STR32XXX, STR32TXXX.

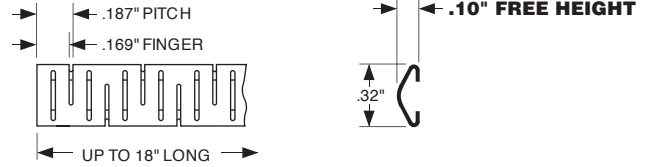

Consult factory for the availability of longer lengths.

187S32

SYMMETRICAL

Compression Force

	25% Compression (0.083")	50% Compression (0.055")
Standard .0035" Thk.	29 lbs/ft	73 lbs/ft
"TF" Style .002" Thk.	13.5 lbs/ft	28.5 lbs/ft

Note: For use with Track TR32, TR32T, STR32XXX, STR32TXXX.

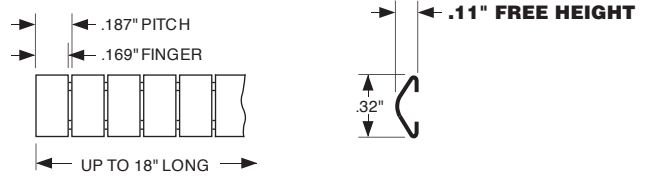

Consult factory for the availability of longer lengths.
See page 5 for rivets and end stops if required.

187AS32

SYMMETRICAL ALTERNATE SLOT

Compression Force

	25% Compression (0.083")	50% Compression (0.055")
Standard .0035" Thk.	29 lbs/ft	73 lbs/ft
"TF" Style .002" Thk.	13.5 lbs/ft	28.5 lbs/ft

Note: For use with Track TR32, TR32T, STR32XXX, STR32TXXX.

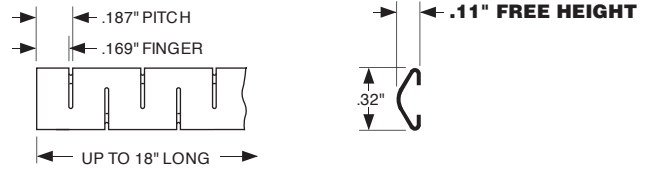

Consult factory for the availability of longer lengths.
See page 5 for rivets and end stops if required.

250S37

SYMMETRICAL

Compression Force

	25% Compression (0.098")	50% Compression (0.065")
Standard .002" Thk.	9 lbs/ft	17 lbs/ft

Note: For use with Track TR37X, STR37XXX, STR37TXXX.

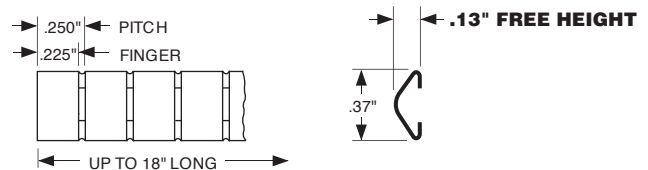

Consult factory for the availability of longer lengths.
See page 5 for rivets and end stops if required.

219S60

SYMMETRICAL

Compression Force

	25% Compression (0.143")	50% Compression (0.095")
Standard .005" Thk.	10 lbs/ft	26 lbs/ft
"TF" Style .003" Thk.	3.8 lbs/ft	9.5 lbs/ft

Note: For use with Track TR60X.

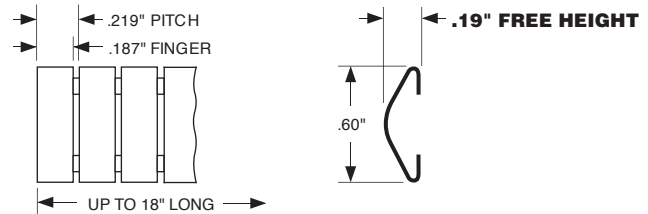

See page 5 for rivets and end stops if required.

250S60

SYMMETRICAL

Compression Force

	25% Compression (0.165")	50% Compression (0.110")
Standard .005" Thk.	11 lbs/ft	27 lbs/ft
"TF" Style .003" Thk.	4.0 lbs/ft	10 lbs/ft

Note: For use with Track TR60X.

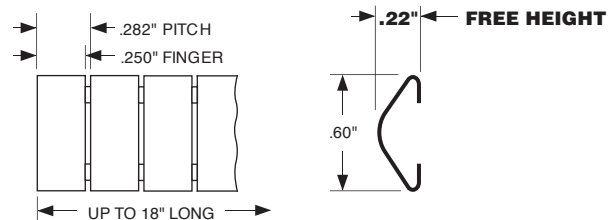

See page 5 for rivets and end stops if required.

Track Mounting

- SEE PAGE 6 FOR HOW TO ORDER
- SEE PAGE 7 FOR SAMPLE REQUEST



375S60

SYMMETRICAL

Compression Force

	25% Compression (0.165")	50% Compression (0.110")
Standard .0035" Thk.	12 lbs/ft	27 lbs/ft
"TF" Style .002" Thk.	3 lbs/ft	8 lbs/ft

Note: For use with Track TR60X.

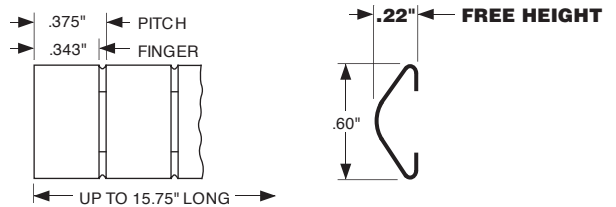

See page 5 for rivets and end stops if required.

375S80

SYMMETRICAL

Compression Force

	25% Compression (0.240")	50% Compression (0.160")
Standard .004" Thk.	17 lbs/ft	34 lbs/ft
"TF" Style .003" Thk.	4 lbs/ft	6 lbs/ft

Note: For use with Track TR80X.

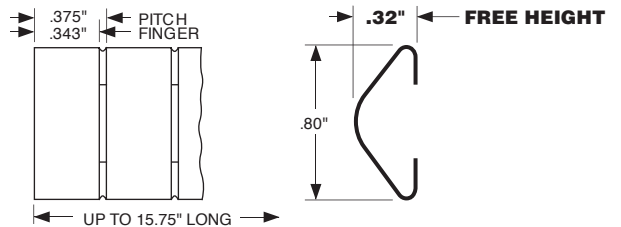

Consult factory for the availability of longer lengths.

Snap-on Mounting

- SEE PAGE 6 FOR HOW TO ORDER
- SEE PAGE 7 FOR SAMPLE REQUEST



187S32

SYMMETRICAL SLOT OR EDGE MOUNT

GAP RANGE UP TO .06"

Standard .0035" Thk.
"TF" Style .002" Thk.

APPLICATION DATA

Notes:

1. Length of slot as required by number of fingers.
2. Spacing determined by attenuation requirements.

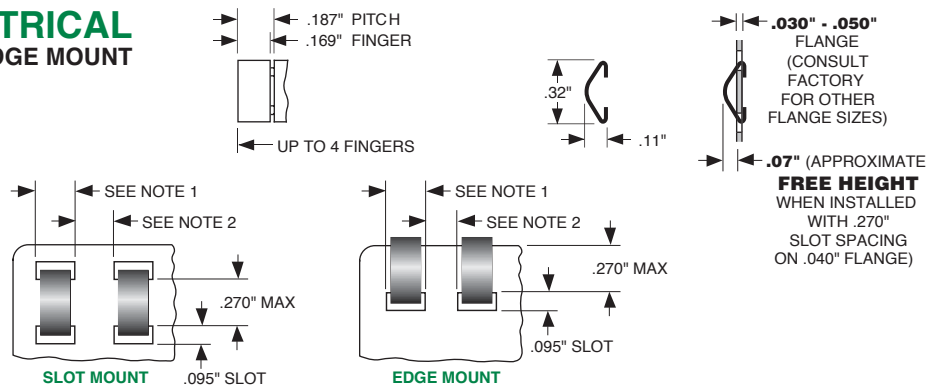

187V32FXx

SYMMETRICAL VARIABLE - SLOT MOUNT

GAP RANGE UP TO .06"

Compression Force

	25% Compression (0.053")	50% Compression (0.035")
Standard .0035" Thk.	2.7 lbs/ft	14 lbs/ft
"TF" Style .002" Thk.	2.5 lbs/ft	6.5 lbs/ft

APPLICATION DATA

Notes:

1. *Actual length determined by finger pattern.
2. See page 4 for standard finger patterns.

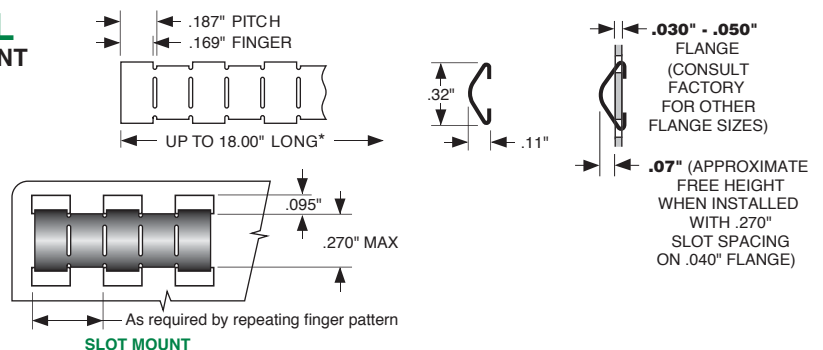

Snap-on Mounting

• SEE PAGE 6 FOR HOW TO ORDER
• SEE PAGE 7 FOR SAMPLE REQUEST



187VE32FXx

SYMMETRICAL VARIABLE - EDGE MOUNT

GAP RANGE UP TO .06"
Compression Force

	25% Compression (0.053")	50% Compression (0.035")
Standard .0035" Thk.	4.1 lbs/ft	14 lbs/ft
"TF" Style .002" Thk.	1.1 lbs/ft	1.3 lbs/ft

APPLICATION DATA

Notes:

- *Actual length determined by finger pattern.
- See page 4 for standard finger patterns.

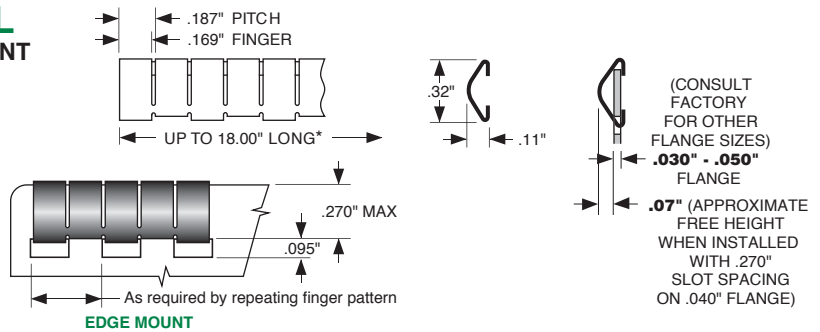

187S30

SYMMETRICAL SLOT OR EDGE MOUNT

GAP RANGE UP TO .06"

Standard .0035" Thk.
"TF" Style .002" Thk.

APPLICATION DATA

Notes:

- Length of slot as required by number of fingers.
- Spacing determined by attenuation requirements.

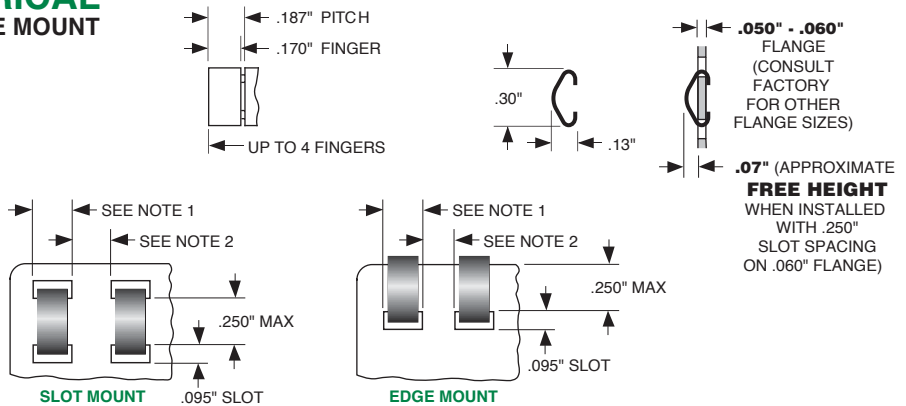

250S37

SYMMETRICAL SLOT OR EDGE MOUNT

GAP RANGE UP TO .075"

Standard .002" Thk.

APPLICATION DATA

Notes:

- Length of slot as required by number of fingers.
- Spacing determined by attenuation requirements.

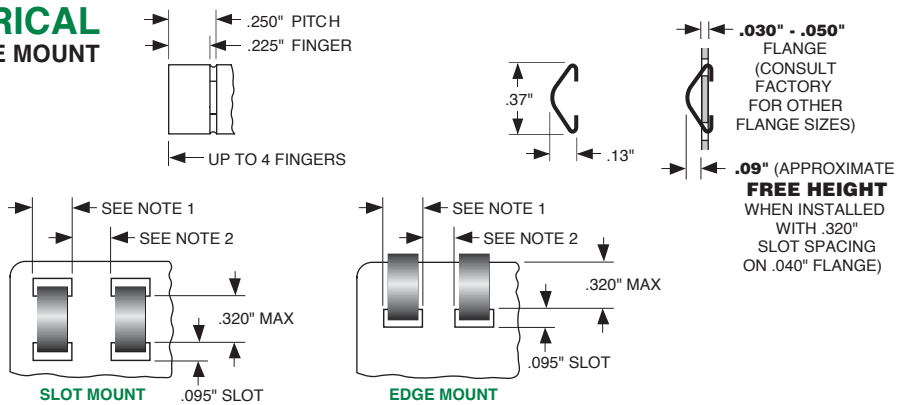

250V37FXx

SYMMETRICAL VARIABLE - SLOT MOUNT

GAP RANGE UP TO .075"

Compression Force

	25% Compression (0.068")	50% Compression (0.045")
Standard .002" Thk.	1.3 lbs/ft	6.9 lbs/ft

APPLICATION DATA

Notes:

- *Actual length determined by finger pattern.
- See page 4 for standard finger patterns.

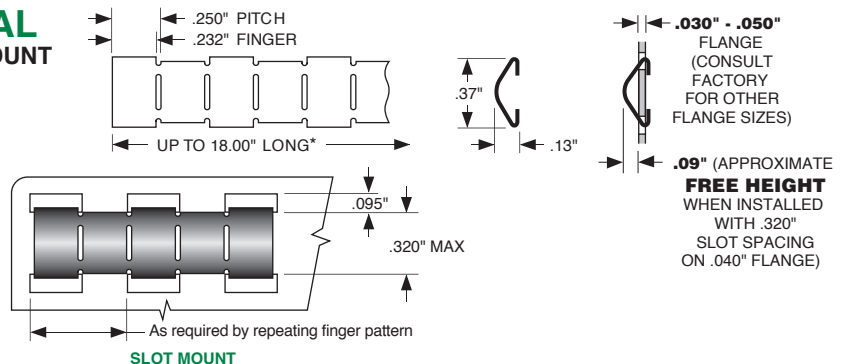

Snap-on Mounting

- SEE PAGE 6 FOR HOW TO ORDER
- SEE PAGE 7 FOR SAMPLE REQUEST



250VE37FXx

SYMMETRICAL VARIABLE - EDGE MOUNT

GAP RANGE UP TO .075"

Compression Force

	25% Compression (0.068")	50% Compression (0.045")
Standard .002" Thk.	1.5 lbs/ft	4.1 lbs/ft

APPLICATION DATA

Notes:

1. *Actual length determined by finger pattern.
2. See page 4 for standard finger patterns.

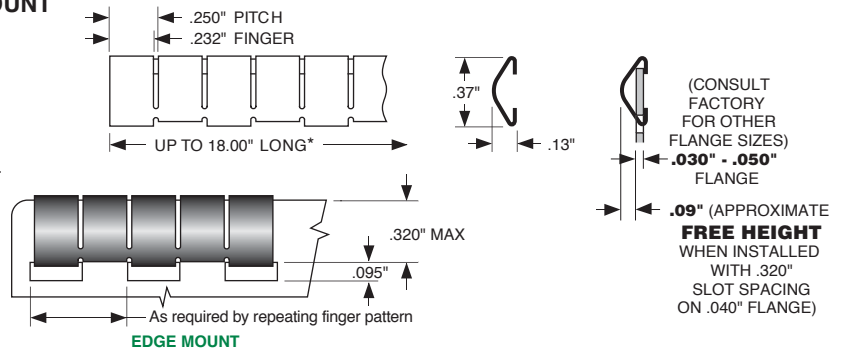

219S60

SYMMETRICAL SLOT OR EDGE MOUNT

GAP RANGE UP TO .113"

Standard .005" Thk.
"TF" Style .003" Thk.

APPLICATION DATA

See 375S60 below.

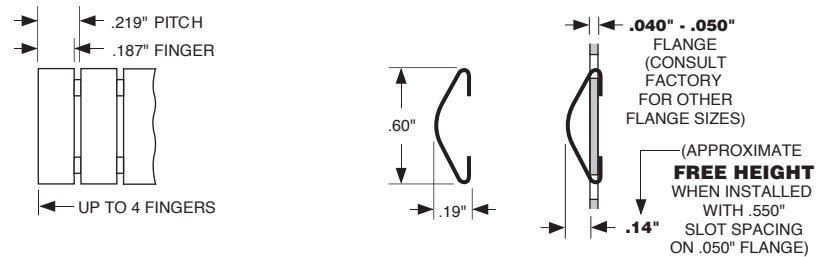

250S60

SYMMETRICAL SLOT OR EDGE MOUNT

GAP RANGE UP TO .120"

Standard .005" Thk.
"TF" Style .003" Thk.

APPLICATION DATA

See 375S60 below.

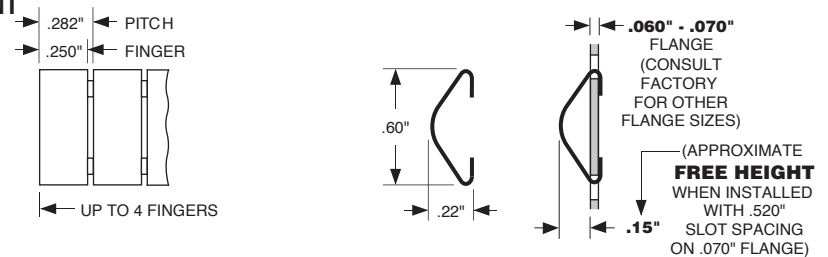

375S60

SYMMETRICAL SLOT OR EDGE MOUNT

GAP RANGE UP TO .120"

Standard .0035" Thk.
"TF" Style .002" Thk.

APPLICATION DATA

Notes:

1. Length of slot as required by number of fingers.
2. Spacing determined by attenuation requirements.

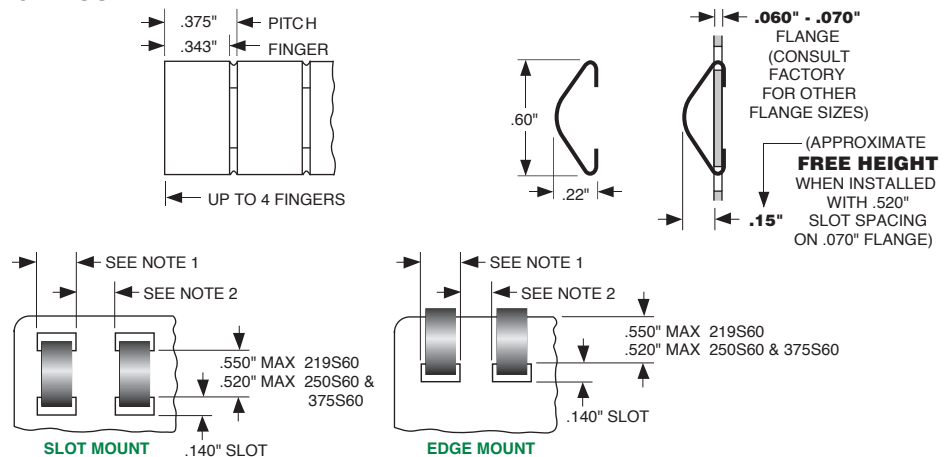

Snap-on Mounting

• SEE PAGE 6 FOR HOW TO ORDER
• SEE PAGE 7 FOR SAMPLE REQUEST



282V60FXx

SYMMETRICAL VARIABLE - SLOT MOUNT

GAP RANGE UP TO .120"

Compression Force

	25% Compression (0.113")	50% Compression (0.075")
Standard .005" Thk.	10 lbs/ft **	27 lbs/ft **
"TF" Style .003" Thk.		

** Note: Consult factory for performance data.

APPLICATION DATA

Notes:

1. *Actual length determined by finger pattern.
2. See page 4 for standard finger patterns.

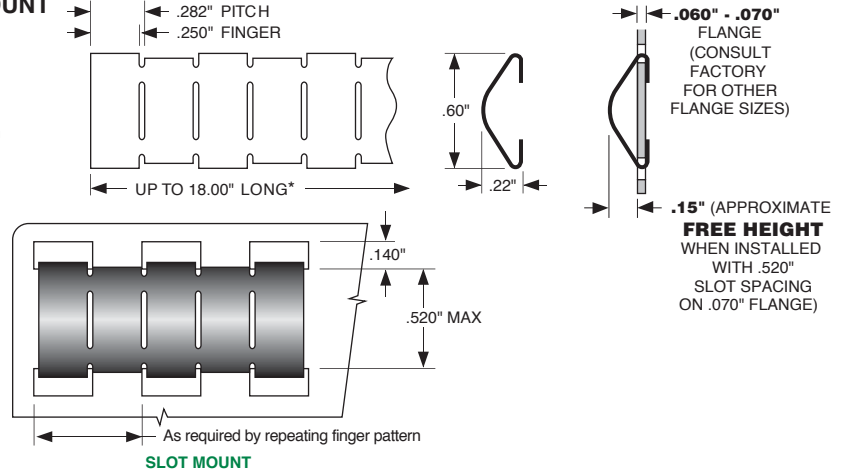

375S80

SYMMETRICAL SLOT OR EDGE MOUNT

GAP RANGE UP TO .195"

Standard .004" Thk.
"TF" Style .003" Thk.

APPLICATION DATA

Notes:

1. Length of slot as required by number of fingers.
2. Spacing determined by attenuation requirements.

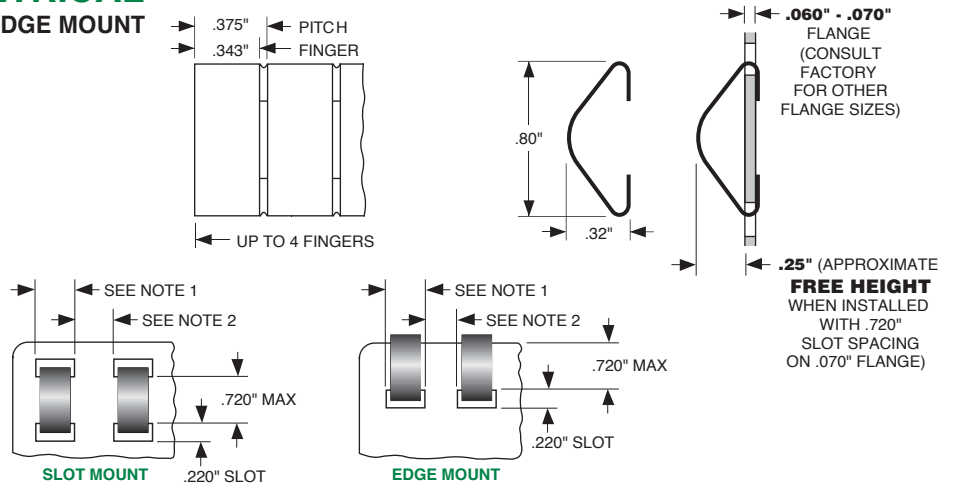

206W36

SOFT NO-SNAG FINGERS SLOT OR EDGE MOUNT

GAP RANGE UP TO .068"

Standard .0025" Thk.

APPLICATION DATA

Notes:

1. Length of slot as required by number of fingers.
2. Spacing determined by attenuation requirements.

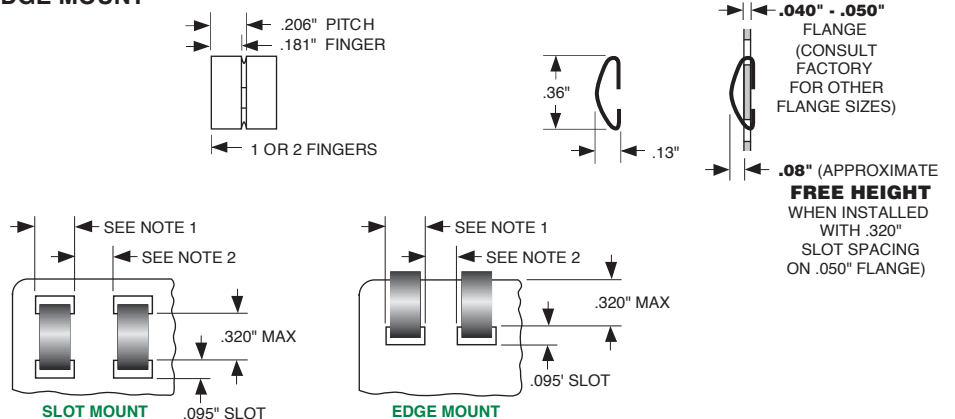

Stick-on Mounting

• SEE PAGE 6 FOR HOW TO ORDER
• SEE PAGE 7 FOR SAMPLE REQUEST

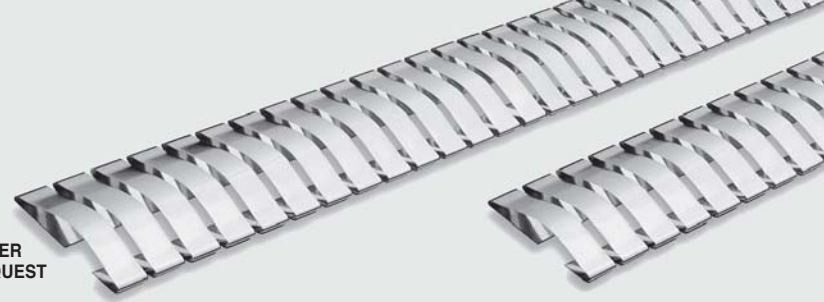

187W35 SOFT NO-SNAG FINGERS

Compression Force

	25% Compression (0.083")	50% Compression (0.055")
Standard .003" Thk.	25 lbs/ft	89 lbs/ft
"TF" Style .002" Thk.	6 lbs/ft	23 lbs/ft

Note: Also available with optional double adhesive transfer tape.

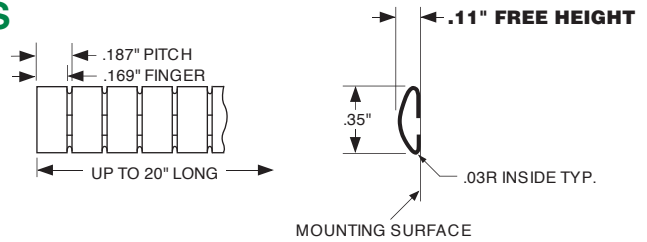

125LPS35 SPIDER LOW PROFILE NO-SNAG

Compression Force

	25% Compression (0.060")	50% Compression (0.040")
Standard .002" Thk.	*	*

* Note: Consult factory for performance data.

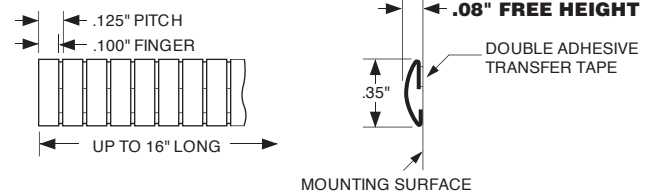

125LPS45H060 SPIDER HOOK & STICK-ON LOW PROFILE NO-SNAG

Compression Force

	25% Compression (0.060")	50% Compression (0.040")
Standard .002" Thk.	*	*

* Note: Consult factory for performance data.

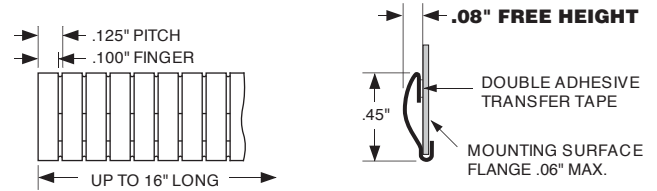

125G28 LOW PROFILE NO-SNAG

Compression Force

	25% Compression (0.045")	50% Compression (0.030")
Standard .002" Thk.	5.5 lbs/ft	20.4 lbs/ft

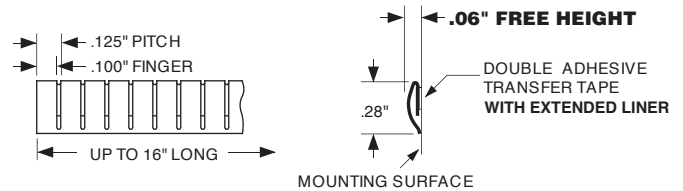

125G32 LOW PROFILE NO-SNAG

Compression Force

	25% Compression (0.060")	50% Compression (0.040")
Standard .002" Thk.	6.8 lbs/ft	17 lbs/ft

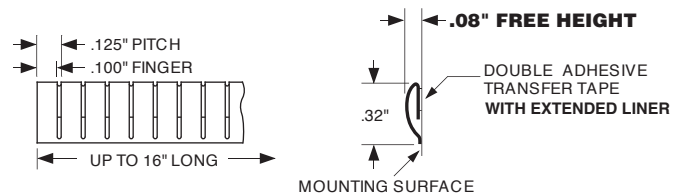

125LP45 LOW PROFILE NO-SNAG

Compression Force

	25% Compression (0.060")	50% Compression (0.040")
Standard .0035" Thk.	10 lbs/ft	19 lbs/ft
"TF" Style .0025" Thk.	8.9 lbs/ft	17 lbs/ft

Note: (SS) Also available in Stainless Steel (SS125LP45)

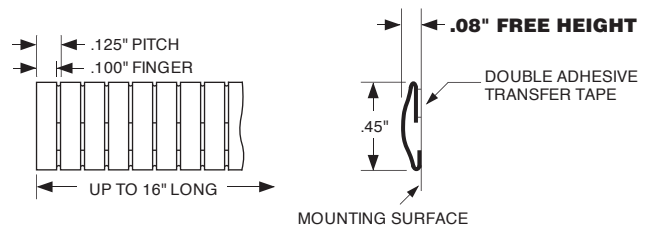

Stick-on Mounting

• SEE PAGE 6 FOR HOW TO ORDER
• SEE PAGE 7 FOR SAMPLE REQUEST

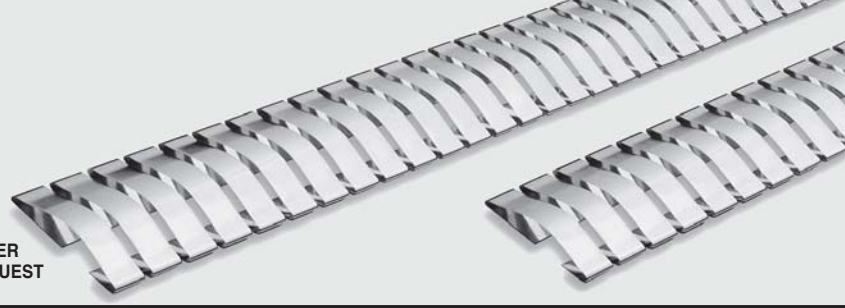

125LP60 LOW PROFILE NO-SNAG

Compression Force

	25% Compression (0.090")	50% Compression (0.060")
Standard .0035" Thk.	12 lbs/ft	24 lbs/ft
"TF" Style .0025" Thk.	5.0 lbs/ft	11 lbs/ft

Note: (SS) Also available in Stainless Steel (SS125LP60)

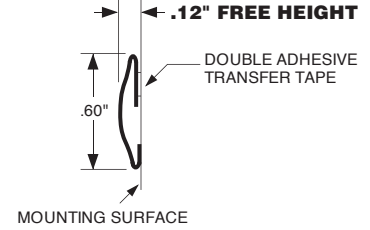
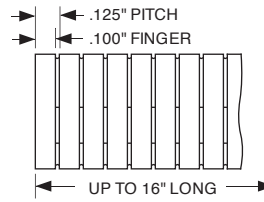

125LP55 LOW PROFILE NO-SNAG

Compression Force

	25% Compression (0.113")	50% Compression (0.075")
Standard .0035" Thk.	19 lbs/ft	35 lbs/ft
"TF" Style .0025" Thk.	7.5 lbs/ft	14 lbs/ft

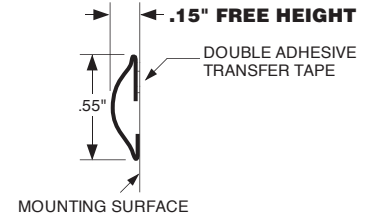
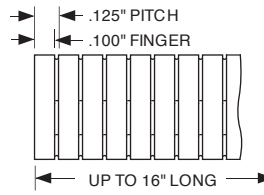

125LP45H060 HOOK & STICK-ON LOW PROFILE NO-SNAG

Compression Force

	25% Compression (0.045")	50% Compression (0.030")
Standard .0035" Thk.	10 lbs/ft	19 lbs/ft
"TF" Style .0025" Thk.	6.4 lbs/ft	17 lbs/ft

Note: (SS) Also available in Stainless Steel (SS125LP45H060)

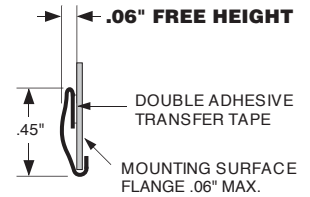
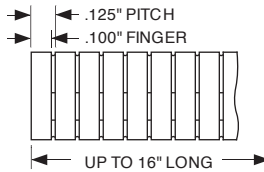

125LP60H060 HOOK & STICK-ON LOW PROFILE NO-SNAG

Compression Force

	25% Compression (0.068")	50% Compression (0.045")
Standard .0035" Thk.	8.7 lbs/ft	17.3 lbs/ft
"TF" Style .0025" Thk.	5.8 lbs/ft	9.0 lbs/ft

Note: (SS) Also available in Stainless Steel (SS125LP60H060)

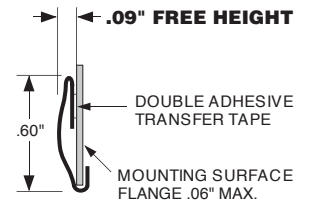
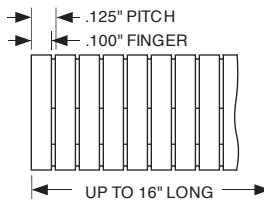

125LP55H060 HOOK & STICK-ON LOW PROFILE NO-SNAG

Compression Force

	25% Compression (0.105")	50% Compression (0.070")
Standard .0035" Thk.	19 lbs/ft	35 lbs/ft
"TF" Style .0025" Thk.	6.8 lbs/ft	14 lbs/ft

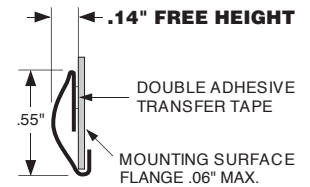
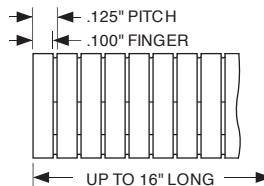

60P21 SOFT NO-SNAG FINGERS

Compression Force

	25% Compression (0.060")	50% Compression (0.040")
Standard .002" Thk.	11 lbs/ft	34 lbs/ft

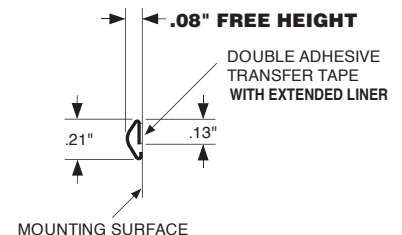
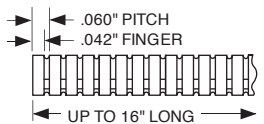

Stick-on Mounting

• SEE PAGE 6 FOR HOW TO ORDER
• SEE PAGE 7 FOR SAMPLE REQUEST



187P21 SOFT NO-SNAG FINGERS

Compression Force

	25% Compression (0.060")	50% Compression (0.040")
Standard .002" Thk.	17 lbs/ft	47 lbs/ft

Note: (SS) Also available in Stainless Steel (SS187P21)

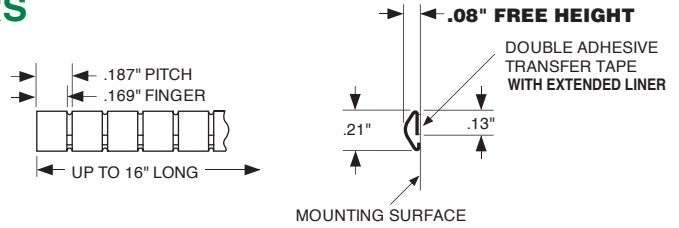

187P28 SOFT FINGERS

Compression Force

	25% Compression (0.083")	50% Compression (0.055")
Standard .002" Thk.	15 lbs/ft	32 lbs/ft

Note: Also available in 25 ft. rolls.

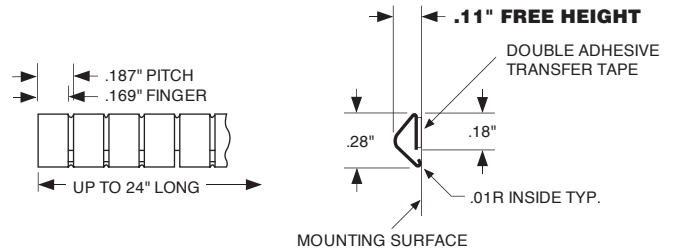

187P32 SOFT NO-SNAG FINGERS

Compression Force

	25% Compression (0.083")	50% Compression (0.055")
Standard .002" Thk.	14 lbs/ft	26 lbs/ft

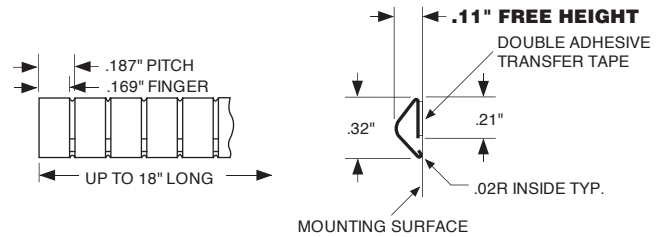

250P37 SOFT NO-SNAG FINGERS

Compression Force

	25% Compression (0.098")	50% Compression (0.065")
Standard .002" Thk.	10 lbs/ft	21 lbs/ft

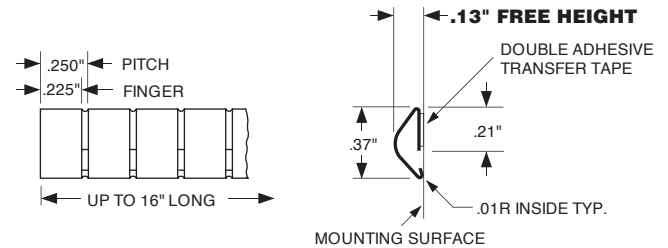

250P37E50 SOFT NO-SNAG FINGERS

Compression Force

	25% Compression (0.098")	50% Compression (0.065")
Standard .002" Thk.	10 lbs/ft	21 lbs/ft

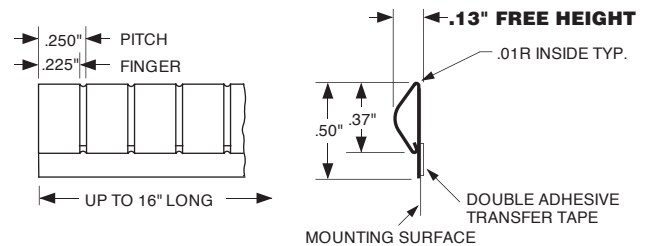

375P60 SOFT NO-SNAG FINGERS

Compression Force

	25% Compression (0.165")	50% Compression (0.110")
Standard .0035" Thk.	10 lbs/ft	20 lbs/ft
"TF" Style .002" Thk.	2.0 lbs/ft	7.2 lbs/ft

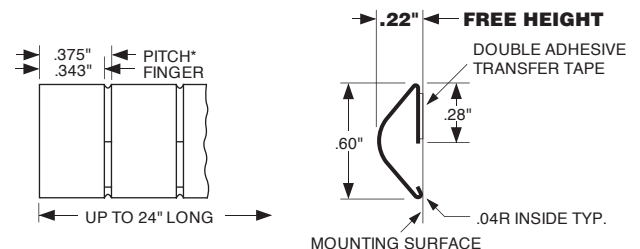

Stick-on Mounting

• SEE PAGE 6 FOR HOW TO ORDER
• SEE PAGE 7 FOR SAMPLE REQUEST



375P80 SOFT NO-SNAG FINGERS

Compression Force

	25% Compression (0.240")	50% Compression (0.160")
Standard .004" Thk.	7 lbs/ft	17 lbs/ft

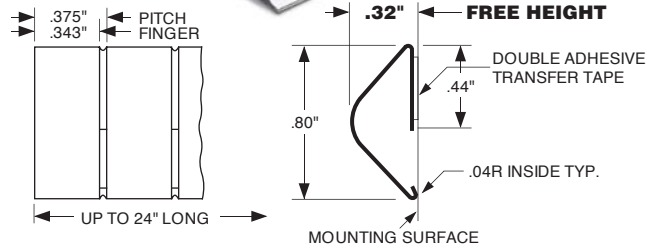

500P110 SOFT NO-SNAG FINGERS

Compression Force

	25% Compression (0.300")	50% Compression (0.200")
Standard .005" Thk.	12 lbs/ft	24 lbs/ft

Note: Up to 18" long.

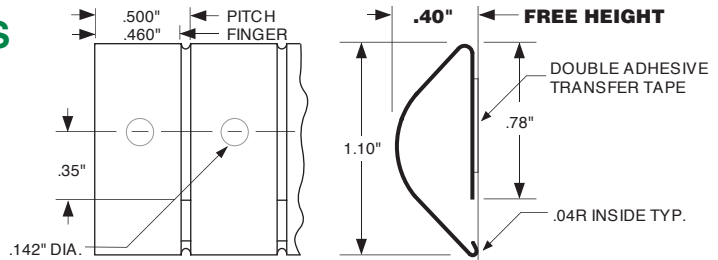

156M32 NO-SNAG FINGERS

Compression Force

	25% Compression (0.075")	50% Compression (0.050")
Standard .0035" Thk.	30 lbs/ft	76 lbs/ft

Note: Also available in .187" Pitch. (187M32)

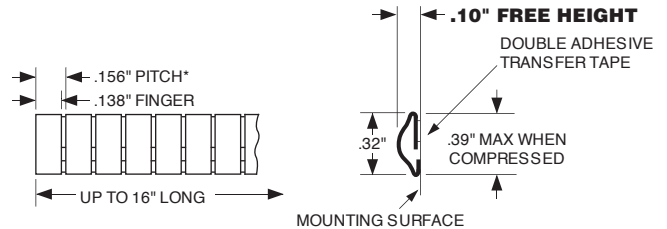

250M37 NO-SNAG FINGERS

Compression Force

	25% Compression (0.098")	50% Compression (0.065")
Standard .0035" Thk.	30 lbs/ft	60 lbs/ft

Note: Also available in .125" Pitch. (125M37)

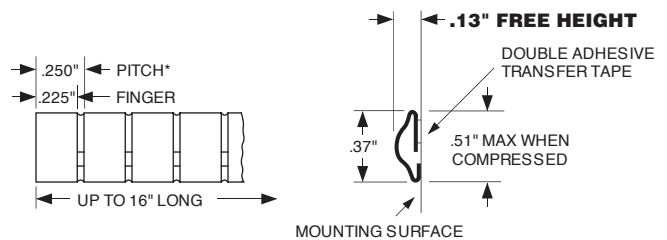

375M60 NO-SNAG FINGERS

Compression Force

	25% Compression (0.165")	50% Compression (0.110")
Standard .0035" Thk.	13 lbs/ft	32 lbs/ft

Note: Also available in .187" Pitch. (187M60)

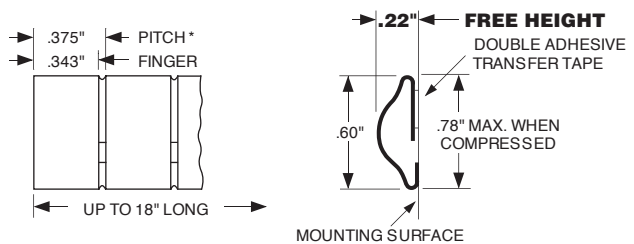

375M60E78 NO-SNAG FINGERS

Compression Force

	25% Compression (0.165")	50% Compression (0.110")
Standard .0035" Thk.	13 lbs/ft	32 lbs/ft

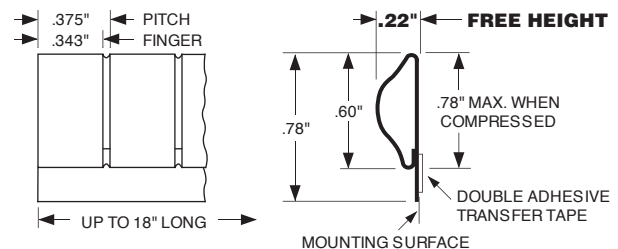

Stick-on Mounting

• SEE PAGE 6 FOR HOW TO ORDER
• SEE PAGE 7 FOR SAMPLE REQUEST

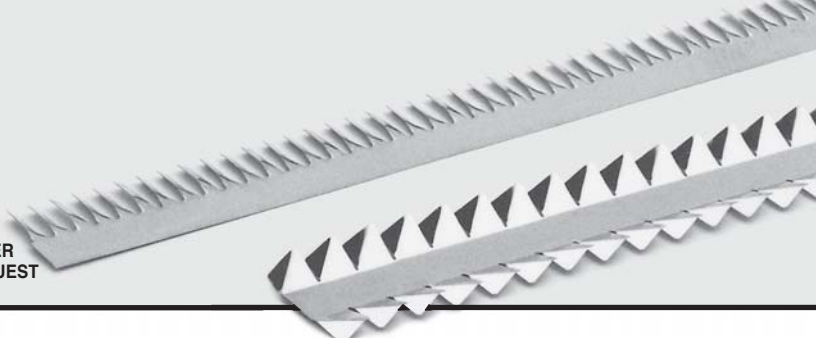

95A TWISTED CONTACTS

Compression Force

	25% Compression (0.023")	50% Compression (0.015")
Standard .005" Thk.	15 lbs/ft	69 lbs/ft

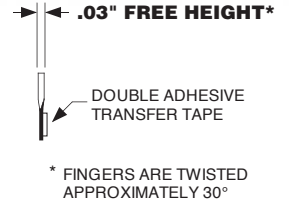
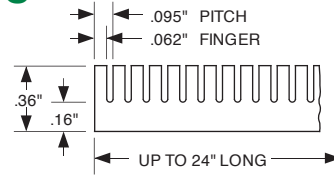

95T TWISTED CONTACTS

Compression Force

	25% Compression (0.023")	50% Compression (0.015")
Standard .003" Thk.	5.8 lbs/ft	35 lbs/ft
"TF" Style .002" Thk.	4.9 lbs/ft	19 lbs/ft

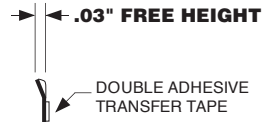
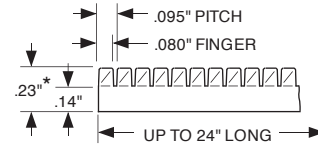

Notes: Also available in 25 ft. rolls. (95TM / TF95TM)
(SS) Also available in Stainless Steel (SS95T)

* COMPRESSED DIM.

95T90° TWISTED CONTACTS

Compression Force

	25% Compression (0.023")	50% Compression (0.015")
Standard .003" Thk.	12 lbs/ft	51 lbs/ft
"TF" Style .002" Thk.	2.5 lbs/ft	10 lbs/ft

Note: (SS) Also available in Stainless Steel (SS95T90°)

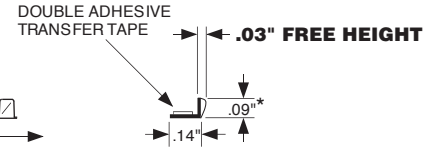
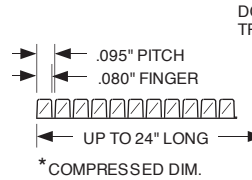

* COMPRESSED DIM.

165TW.300 TWISTED CONTACTS

Compression Force

	25% Compression (0.053")	50% Compression (0.035")
Standard .003" Thk.	18 lbs/ft	36 lbs/ft

Note: Also available in 25 ft. rolls. (165TMW.300)

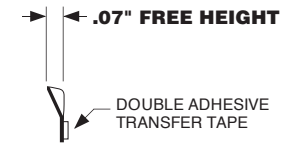
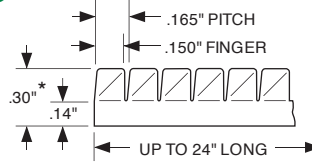

* COMPRESSED DIM.

165T TWISTED CONTACTS

Compression Force

	25% Compression (0.053")	50% Compression (0.035")
Standard .003" Thk.	18 lbs/ft	36 lbs/ft
"TF" Style .002" Thk.	4.2 lbs/ft	11 lbs/ft

Notes: Also available in 25 ft. rolls. (165TM / TF165TM)
(SS) Also available in Stainless Steel (SS165T)

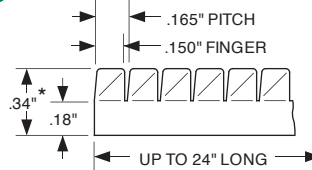

* COMPRESSED DIM.

165T90° TWISTED CONTACTS

Compression Force

	25% Compression (0.053")	50% Compression (0.035")
Standard .003" Thk.	18 lbs/ft	36 lbs/ft
"TF" Style .002" Thk.	4.2 lbs/ft	11 lbs/ft

Note: (SS) Also available in Stainless Steel (SS165T90°)

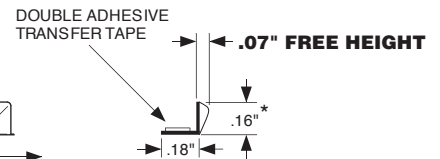
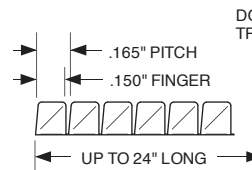

* COMPRESSED DIM.

Stick-on Mounting

• SEE PAGE 6 FOR HOW TO ORDER
• SEE PAGE 7 FOR SAMPLE REQUEST



165T2 TWISTED CONTACTS

Compression Force

	25% Compression (0.053")	50% Compression (0.035")
Standard .003" Thk.	19 lbs/ft	38 lbs/ft

Note: Also available in 25 ft. rolls. (165T2M)

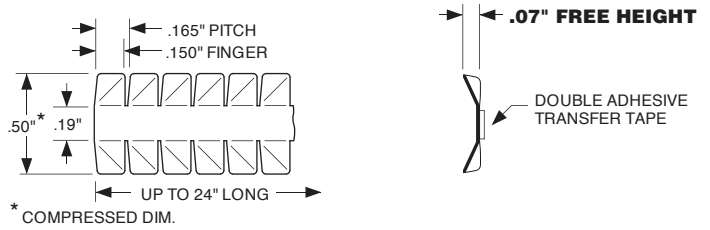

250T TWISTED CONTACTS

Compression Force

	25% Compression (0.090")	50% Compression (0.060")
Standard .003" Thk.	5.0 lbs/ft	11 lbs/ft

Note: Also available in 25 ft. rolls. (250TM)

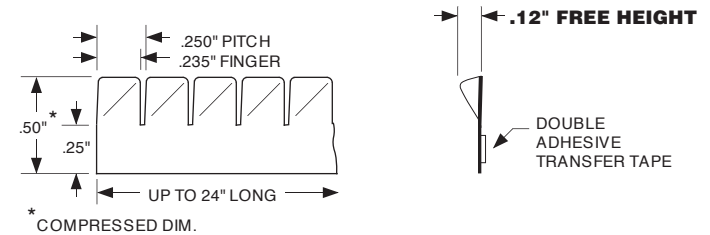

500T TWISTED CONTACTS

Compression Force

	25% Compression (0.158")	50% Compression (0.105")
Standard .004" Thk.	14 lbs/ft	21 lbs/ft

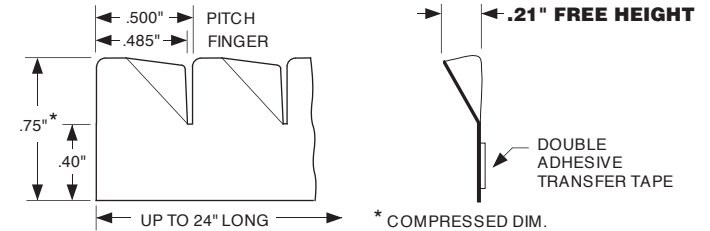

LP45 SLOTLESS GASKET

Compression Force

	25% Compression (0.060")	50% Compression (0.040")
Standard .0035" Thk.	12 lbs/ft	50 lbs/ft
"TF" Style .0025" Thk.	*	*

* Note: Consult factory for performance data.

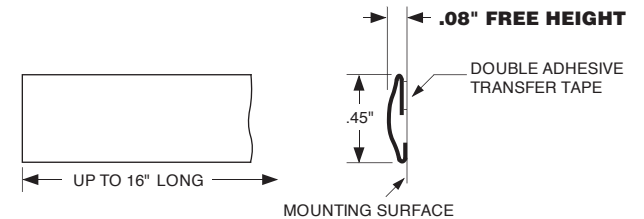

LP60 SLOTLESS GASKET

Compression Force

	25% Compression (0.090")	50% Compression (0.060")
Standard .0035" Thk.	13 lbs/ft	35 lbs/ft
"TF" Style .0025" Thk.	*	*

* Note: Consult factory for performance data.

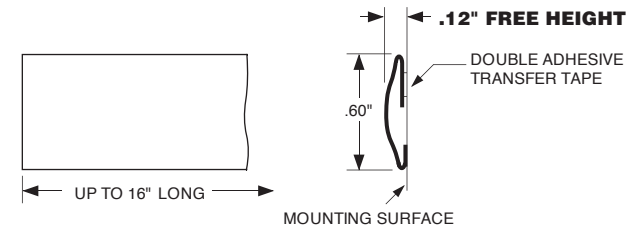

SS725EXS-2 EXPANSION SLOT GASKET

Stainless Steel
.004" Thk.

Note: Drawing shown at reduced scale.

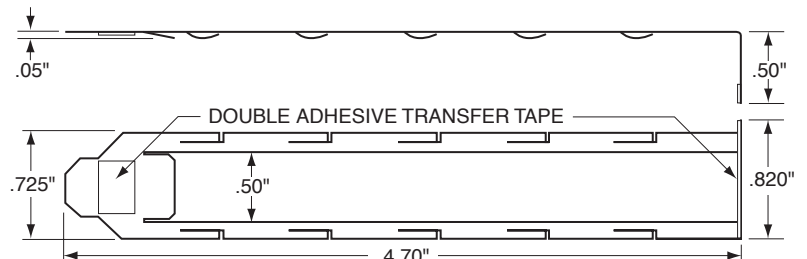

Clip-on Mounting

- SEE PAGE 6 FOR HOW TO ORDER
- SEE PAGE 7 FOR SAMPLE REQUEST



250K4C070 PERPENDICULAR CONTACT

Compression Force

	25% Compression (0.180")	50% Compression (0.120")
Standard .005" Thk.	*	*
"TF" Style .003" Thk.	*	*

* Note: Consult factory for performance data.

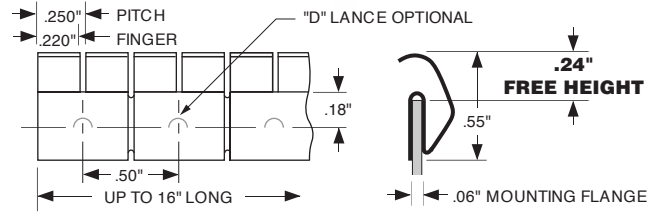

250C040 LOW PROFILE

Compression Force

	25% Compression (0.045")	50% Compression (0.030")
Standard .006" Thk.	15 lbs/ft	83 lbs/ft
"TF" Style .0035" Thk.	6.6 lbs/ft	30 lbs/ft

Notes: Optional lance available as shown.

(SS) Also available in Stainless Steel (SS250C040)

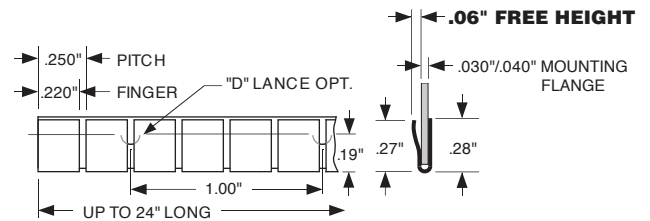

125LP55C070 LOW PROFILE

Compression Force

	25% Compression (0.060")	50% Compression (0.040")
Standard .0035" Thk.	9.6 lbs/ft	32 lbs/ft
"TF" Style .0025" Thk.	5.7 lbs/ft	17 lbs/ft

Note: See page 4 for available lances.

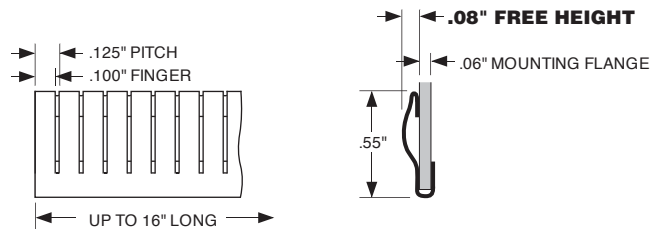

125LP75C070 LOW PROFILE

Compression Force

	25% Compression (0.090")	50% Compression (0.060")
Standard .0035" Thk.	7.3 lbs/ft	23 lbs/ft
"TF" Style .0025" Thk.	2.5 lbs/ft	8.9 lbs/ft

Note: See page 4 for available lances.

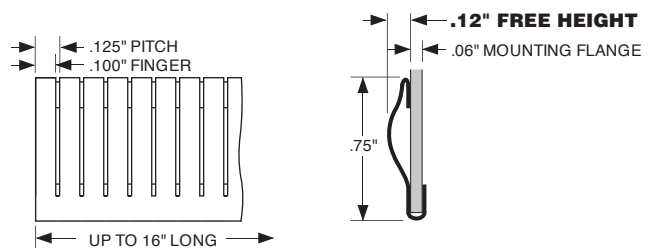

187RGCXXX CYLINDRICAL RADIUS

Compression Force

	25% Compression (0.060")	50% Compression (0.040")
Standard .005" Thk.	12 lbs/ft	93 lbs/ft

Note: See page 4 for available lances.

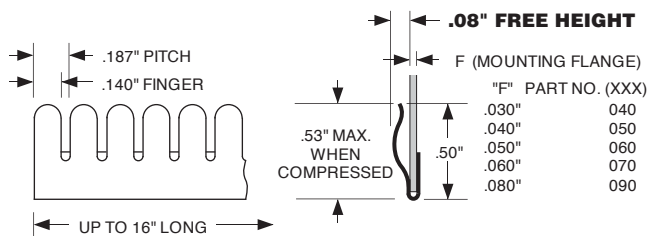

187RF2CXXX CYLINDRICAL RADIUS

Compression Force

	25% Compression (0.060")	50% Compression (0.040")
Standard .005" Thk.	23 lbs/ft	140 lbs/ft

Note: See page 4 for available lances.

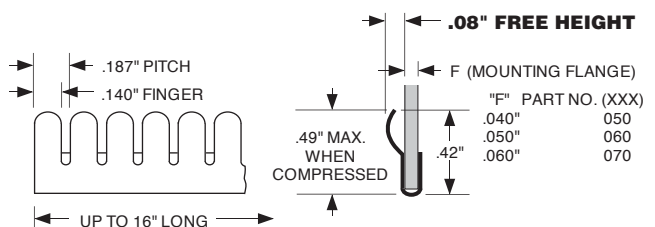

Clip-on Mounting

• SEE PAGE 6 FOR HOW TO ORDER
• SEE PAGE 7 FOR SAMPLE REQUEST



182RF9CXXXL CYLINDRICAL RADIUS

Compression Force

	25% Compression (0.075")	50% Compression (0.050")
Standard .005" Thk.	14 lbs/ft	49 lbs/ft
"TF" Style .003" Thk.	4.5 lbs/ft	22 lbs/ft

Note: Non-standard lance location(s).

(SS) Also available in Stainless Steel (SS182RF9CXXXL)

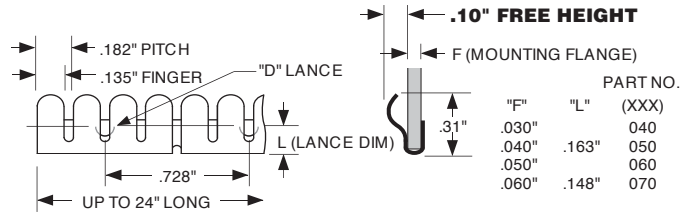

187RF1CXXX CYLINDRICAL RADIUS

Compression Force

	25% Compression (0.090")	50% Compression (0.060")
Standard .005" Thk.	12 lbs/ft	84 lbs/ft
"TF" Style .0035" Thk.	*	*

Notes: See page 4 for available lances.

* Consult factory for performance data.

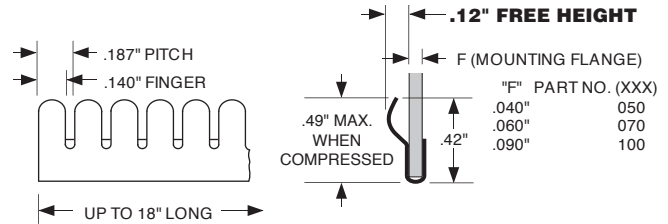

187RF3CXXX CYLINDRICAL RADIUS

Compression Force

	25% Compression (0.105")	50% Compression (0.070")
Standard .005" Thk.	18 lbs/ft	N/A
"TF" Style .0035" Thk.	*	*

Notes: See page 4 for available lances.

* Consult factory for performance data.

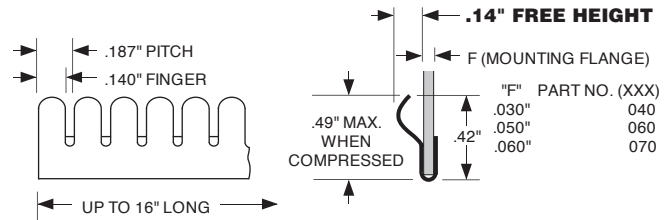

187RF4C070 CYLINDRICAL RADIUS

Compression Force

	25% Compression (0.120")	50% Compression (0.080")
Standard .005" Thk.	11 lbs/ft	69 lbs/ft
"TF" Style .0035" Thk.	6.9 lbs/ft	21 lbs/ft

Note: See page 4 for available lances.

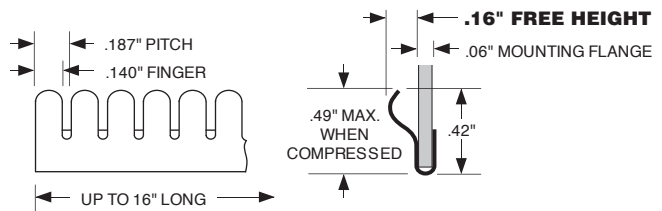

182RF8CXXXL CYLINDRICAL RADIUS

Compression Force

	25% Compression (0.158")	50% Compression (0.105")
Standard .005" Thk.	3.5 lbs/ft	16 lbs/ft

Note: Non-standard lance location(s).

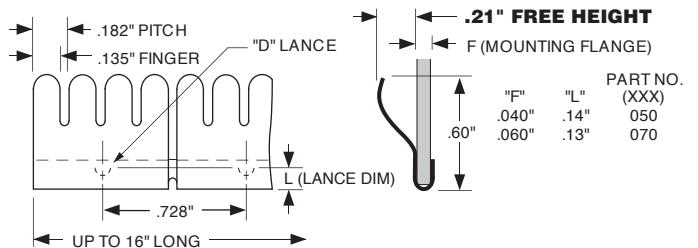

375CXXX STRIP GASKETS

Compression Force

	25% Compression (0.195")	50% Compression (0.130")
Standard .005" Thk.	17 lbs/ft	43 lbs/ft

Note: Drawing shown at reduced scale.

See page 4 for available lances.

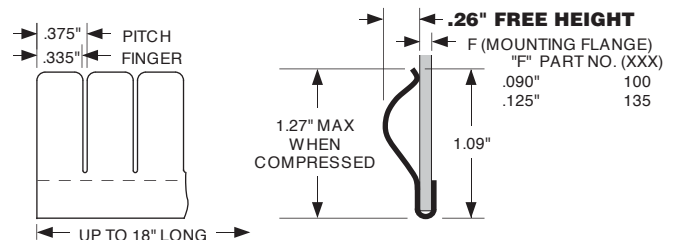

Clip-on Mounting

• SEE PAGE 6 FOR HOW TO ORDER
• SEE PAGE 7 FOR SAMPLE REQUEST



250KC070L REVERSE BEND CONTACTS

Compression Force

	25% Compression (0.150")	50% Compression (0.100")
Standard .005" Thk.	5 lbs/ft	15 lbs/ft

Note: Non-standard lance location(s). Also available in 25 ft. rolls.
Scores for break off between 1/2" increments optional.

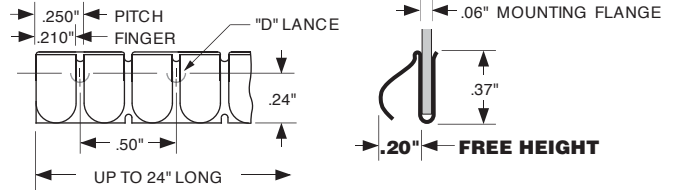

250K2C070L REVERSE BEND CONTACTS

Compression Force

	25% Compression (0.203")	50% Compression (0.135")
Standard .005" Thk.	5 lbs/ft	15 lbs/ft

Note: Non-standard lance location(s). Also available in 25 ft. rolls.
Scores for break off between 1/2" increments optional.

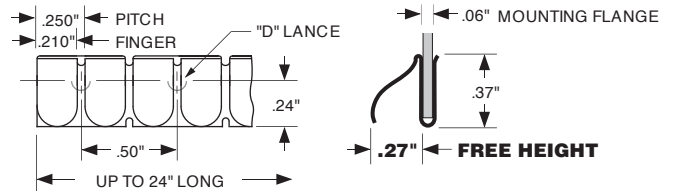

187KC080 REVERSE BEND CONTACTS

Compression Force

	25% Compression (0.188")	50% Compression (0.125")
Standard .005" Thk.	12 lbs/ft	44 lbs/ft

Note: See page 4 for available lances.

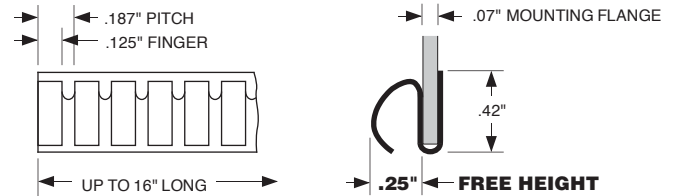

165TC070 TWISTED CONTACTS

Compression Force

	25% Compression (0.053")	50% Compression (0.035")
Standard .003" Thk.	10 lbs/ft	22 lbs/ft

Note: See page 4 for available lances.

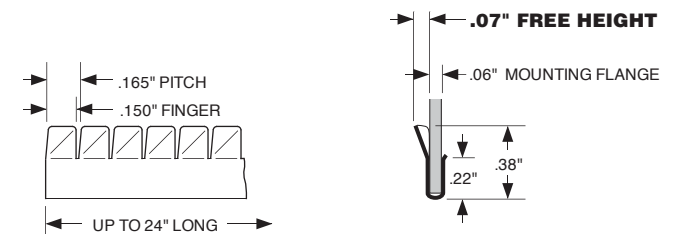

165TCXXXM TWISTED CONTACTS

Compression Force

	25% Compression (0.053")	50% Compression (0.035")
Standard .003" Thk.	10 lbs/ft	22 lbs/ft

Note: See page 4 for available lances.
* Consult factory for longer lengths.

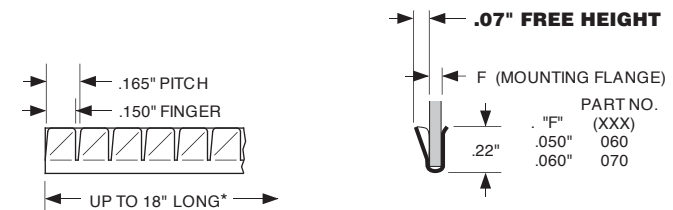

95TCXXX TWISTED CONTACTS

Compression Force

	25% Compression (0.023")	50% Compression (0.015")
Standard .003" Thk.	32 lbs/ft	48 lbs/ft

Note: Optional lance available as shown.
* Consult factory for longer lengths.

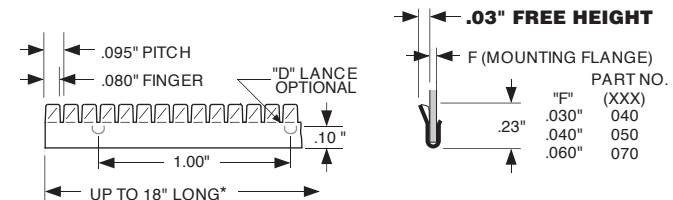

Clip-on Mounting

• SEE PAGE 6 FOR HOW TO ORDER
• SEE PAGE 7 FOR SAMPLE REQUEST



95TCXXXM

TWISTED CONTACTS

Compression Force

	25% Compression (0.023")	50% Compression (0.015")
Standard .003" Thk.	32 lbs/ft	48 lbs/ft

Note: Optional lance available as shown.
* Consult factory for longer lengths.

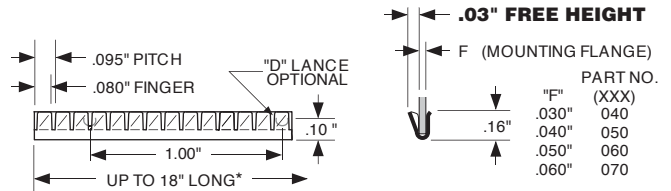

125M42CXXX

NO-SNAG FINGERS

Compression Force

	25% Compression (0.090")	50% Compression (0.060")
Standard .0035" Thk.	23 lbs/ft	55 lbs/ft
"TF" Style .0025" Thk.	12 lbs/ft	28 lbs/ft

* Note: See page 4 for available lances.

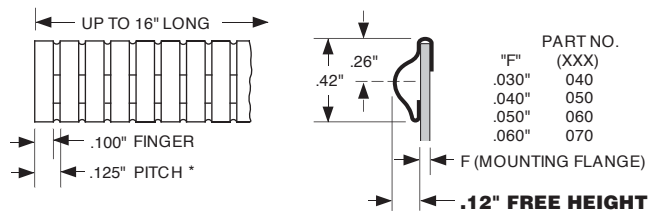

250M42CXXX

NO-SNAG FINGERS

Compression Force

	25% Compression (0.090")	50% Compression (0.060")
Standard .0035" Thk.	29 lbs/ft	69 lbs/ft
"TF" Style .0025" Thk.	15 lbs/ft	35 lbs/ft

* Note: See page 4 for available lances.

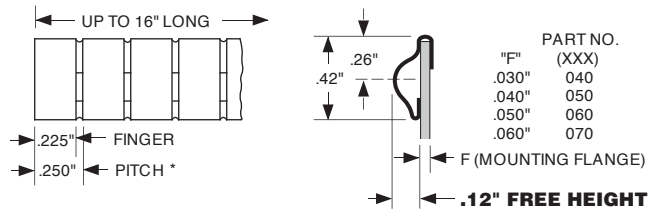

375P64C070

SOFT NO-SNAG FINGERS

Compression Force

	25% Compression (0.165")	50% Compression (0.110")
Standard .0035" Thk.	18 lbs/ft	36 lbs/ft

Note: See page 4 for available lances.

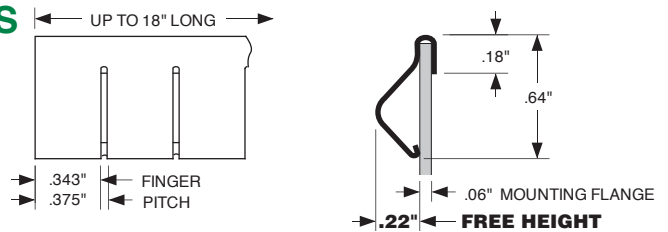

Special Mounting

• SEE PAGE 6 FOR HOW TO ORDER
• SEE PAGE 7 FOR SAMPLE REQUEST

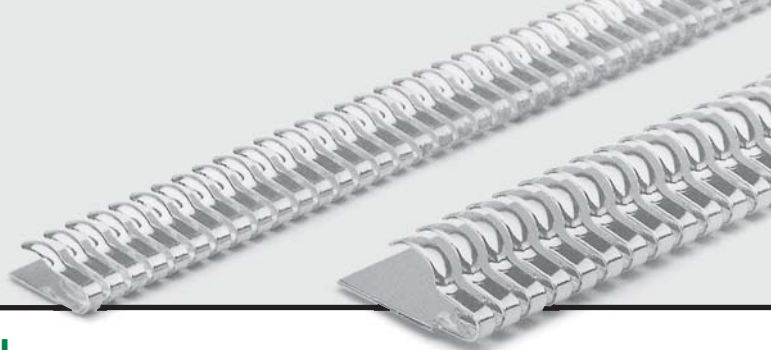

60RC REVERSE BEND SPHERICAL

Compression Force

	25% Compression (0.068")	50% Compression (0.045")
Standard .004" Thk.	7 lbs/ft	10 lbs/ft

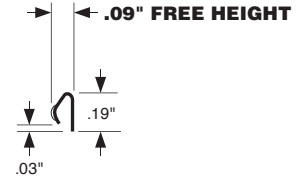
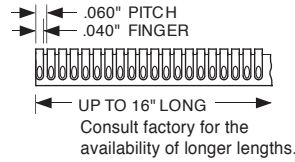

75RC REVERSE BEND SPHERICAL

Standard .006" Thk.

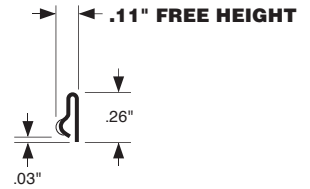
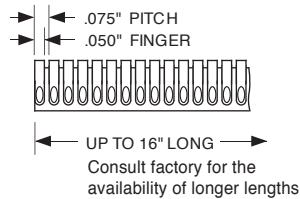

93R1D REVERSE BEND SPHERICAL

Compression Force

	25% Compression (0.120")	50% Compression (0.080")
Standard .010" Thk.	15 lbs/ft	47 lbs/ft

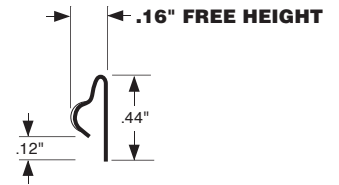
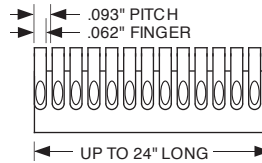

60D REVERSE BEND CONTACTS

Compression Force

	25% Compression (0.053")	50% Compression (0.035")
Standard .004" Thk.	18 lbs/ft	41 lbs/ft

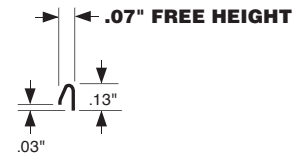
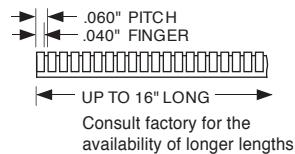

127A REVERSE BEND CONTACTS

Compression Force

	25% Compression (0.068")	50% Compression (0.045")
Standard .005" Thk.	18 lbs/ft	49 lbs/ft

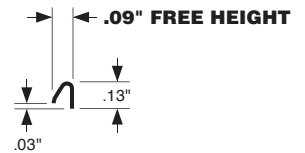
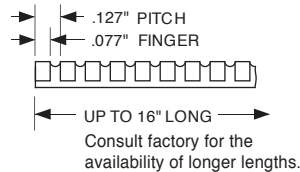

187RD2 REVERSE BEND CONTACTS

Standard .005" Thk.

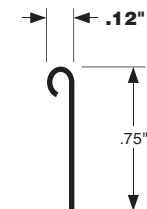
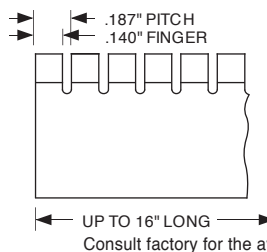

Special Mounting

• SEE PAGE 6 FOR HOW TO ORDER
• SEE PAGE 7 FOR SAMPLE REQUEST

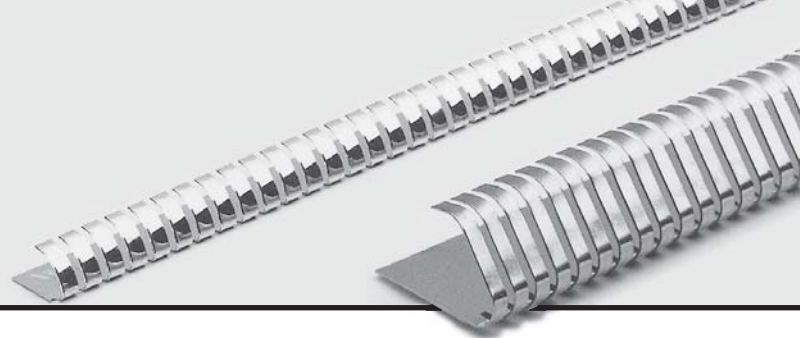

134B REVERSE BEND CONTACTS

Compression Force

	25% Compression (0.098")	50% Compression (0.065")
Standard .010" Thk.	4 lbs/ft	96 lbs/ft

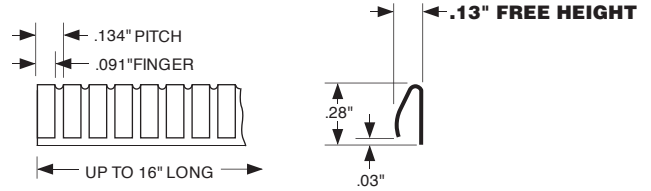

145A REVERSE BEND CONTACTS

Compression Force

	25% Compression (0.098")	50% Compression (0.065")
Standard .010" Thk.	20 lbs/ft	61 lbs/ft

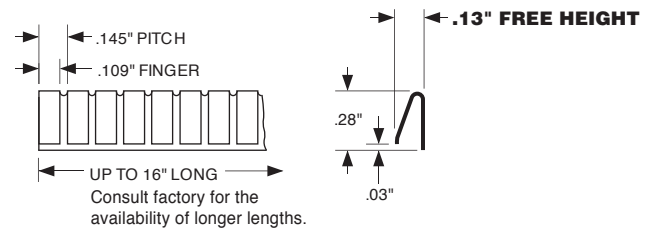

134C REVERSE BEND CONTACTS

Compression Force

	25% Compression (0.150")	50% Compression (0.100")
Standard .010" Thk.	18 lbs/ft	160 lbs/ft
"TF" Style .005" Thk.	7 lbs/ft	27 lbs/ft

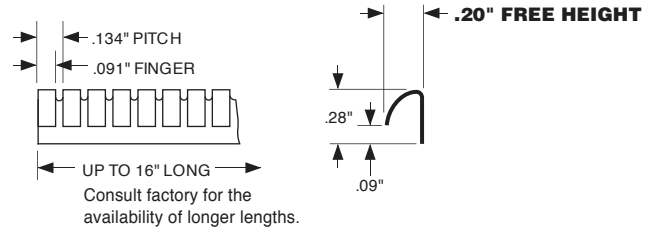

187RD REVERSE BEND CONTACTS

Standard .005" Thk.

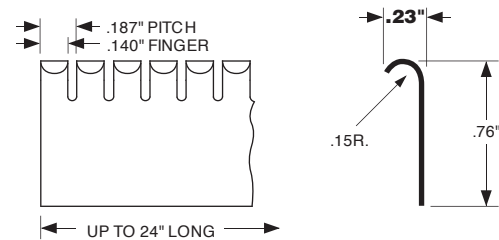

187H REVERSE BEND CONTACTS

Compression Force

	25% Compression (0.210")	50% Compression (0.140")
Standard .006" Thk.	5.0 lbs/ft	15 lbs/ft

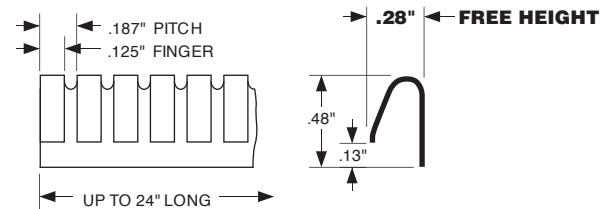

134D REVERSE BEND CONTACTS

Compression Force

	25% Compression (0.330")	50% Compression (0.220")
Standard .010" Thk.	16 lbs/ft	46 lbs/ft

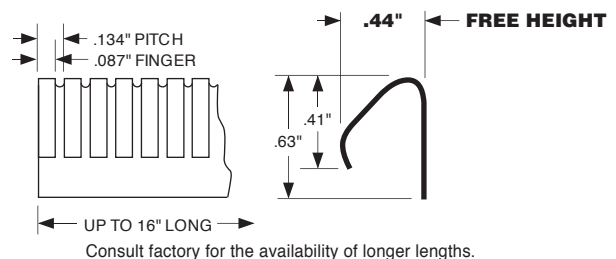

Special Mounting

• SEE PAGE 6 FOR HOW TO ORDER
• SEE PAGE 7 FOR SAMPLE REQUEST

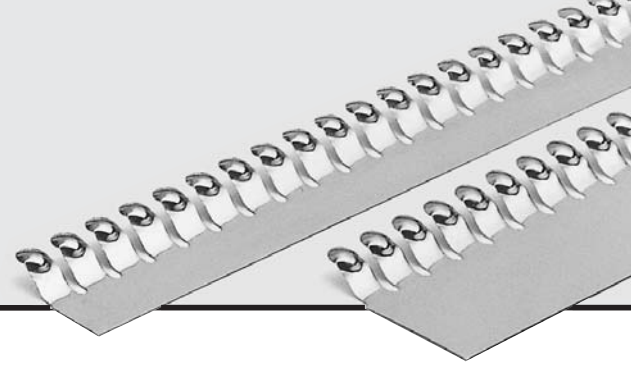

60R

SPHERICAL RADIUS

Standard .004" Thk.

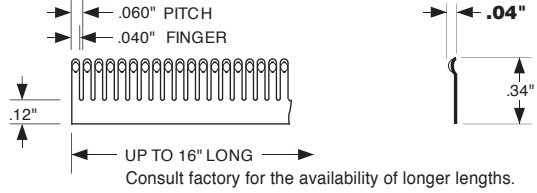

75RF

SPHERICAL RADIUS

Standard .006" Thk.

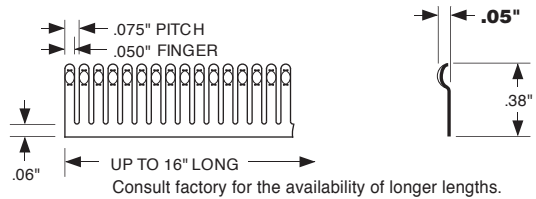

75RE

SPHERICAL RADIUS

Standard .006" Thk.

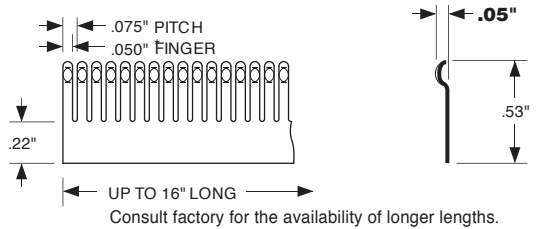

187RB1

SPHERICAL RADIUS

Standard .005" Thk.

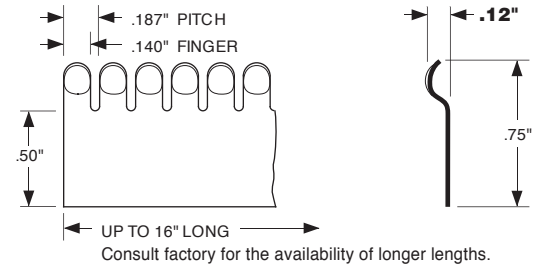

187RB

CYLINDRICAL RADIUS

Compression Force

	25% Compression (0.068")	50% Compression (0.045")
Standard .005" Thk.	3.0 lbs/ft	6.0 lbs/ft

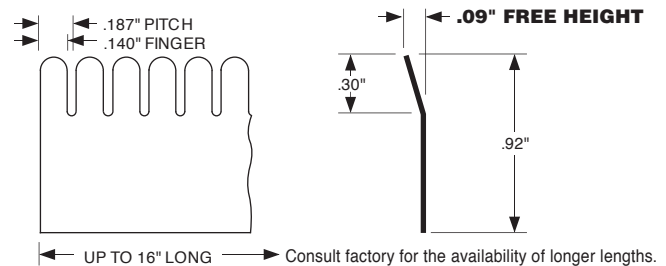

187RC

CYLINDRICAL RADIUS

Standard .005" Thk.

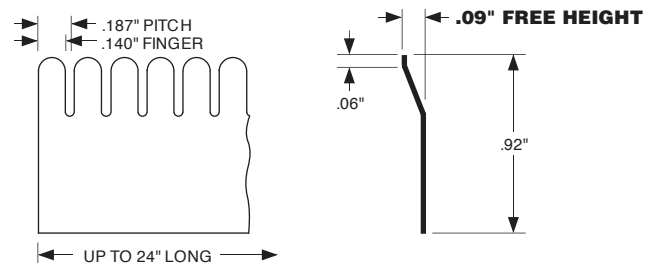

Special Mounting

• SEE PAGE 6 FOR HOW TO ORDER
• SEE PAGE 7 FOR SAMPLE REQUEST



187RJ

CYLINDRICAL RADIUS

Standard .005" Thk.

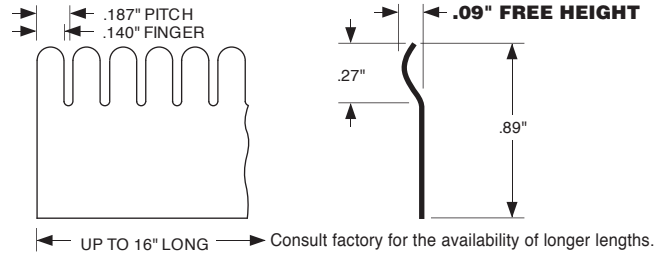

187RA

CYLINDRICAL RADIUS

Compression Force

	25% Compression (0.090")	50% Compression (0.060")
Standard .005" Thk.	8.0 lbs/ft	37 lbs/ft

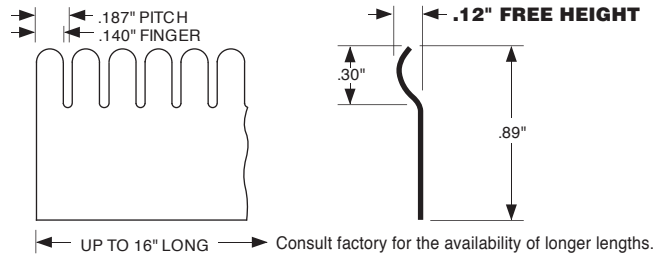

187R₂A

CYLINDRICAL RADIUS

Compression Force

	25% Compression (0.090")	50% Compression (0.060")
Standard .004" Thk.	17 lbs/ft	73 lbs/ft

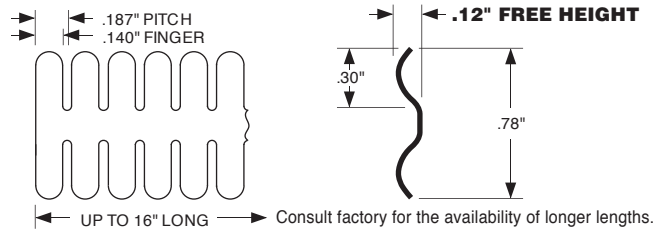

375B

CYLINDRICAL RADIUS

Compression Force

	25% Compression (0.165")	50% Compression (0.110")
Standard .004" Thk.	18 lbs/ft	48 lbs/ft

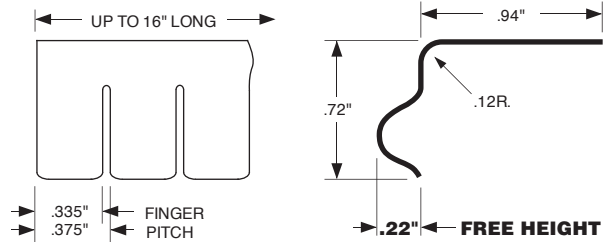

375A

STRIP GASKETS

Compression Force

	25% Compression (0.195")	50% Compression (0.130")
Standard .005" Thk.	15 lbs/ft	41 lbs/ft

Note: Drawing shown at reduced scale.

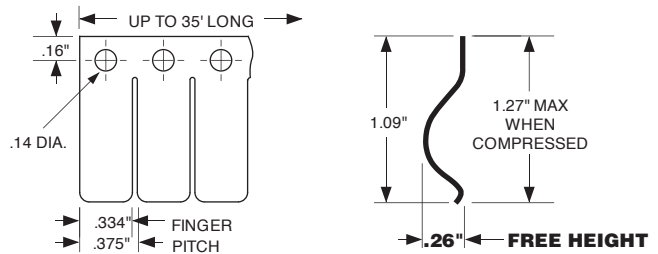

500A

STRIP GASKETS

Compression Force

	25% Compression (0.308")	50% Compression (0.205")
Standard .007" Thk.	16 lbs/ft	32 lbs/ft

Note: Drawing shown at reduced scale.

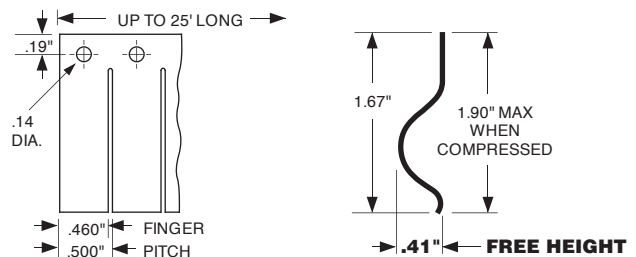

Board Level Shielding



Tech-Etch specializes in the design and production of custom board level shielding. The photoetching process allows the fabrication of parts with complex shapes and features that are impossible to duplicate by other methods without expensive tooling.

- **Improve flexibility of design**
- **Non-recurring charges frequently less than \$400.00**
- **Can specify more intricate geometry**
- **Shortens lead times and forming tools not required**
- **Mounting pin styles in any configuration**
- **Through holes and slots available for heat dissipation**
- **Soldered or resistance welded seams optional**
- **Custom fence/removable cover option**
- **Form tooling exists for standard spring finger design**

TWO PIECE ENCLOSURE

REMOVABLE COVER

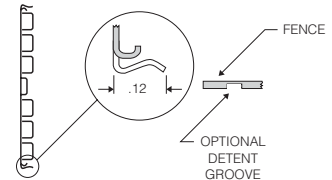
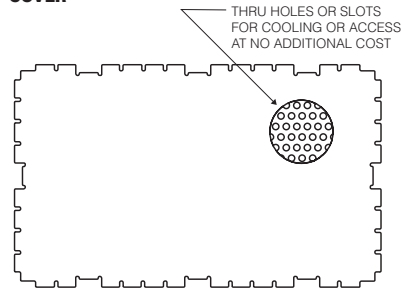

FENCE

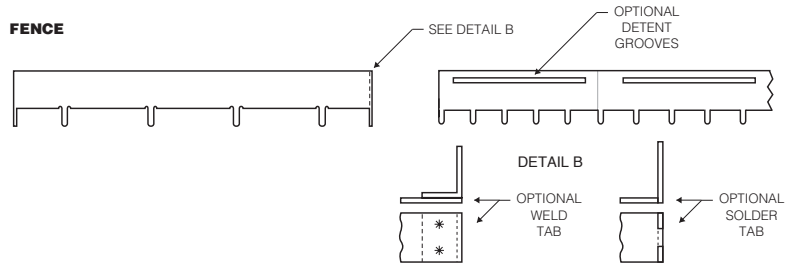

MATERIALS

Board level shielding is typically etched from .007" - .020" brass, nickel silver, copper or cold rolled steel. Board level shielding can also be manufactured out of beryllium copper, if spring qualities are desired. The standard finish is tin plate. Other finishes are available.

FORMING

Depth-etch bend lines allow forming without tooling by the customer or the factory.

EXAMPLES AVAILABLE

If you need additional information or samples of board level shielding, call or fax us. Our customer service/engineering department will be glad to help you determine appropriate specifications for your board level shielding application.

ONE PIECE ENCLOSURE

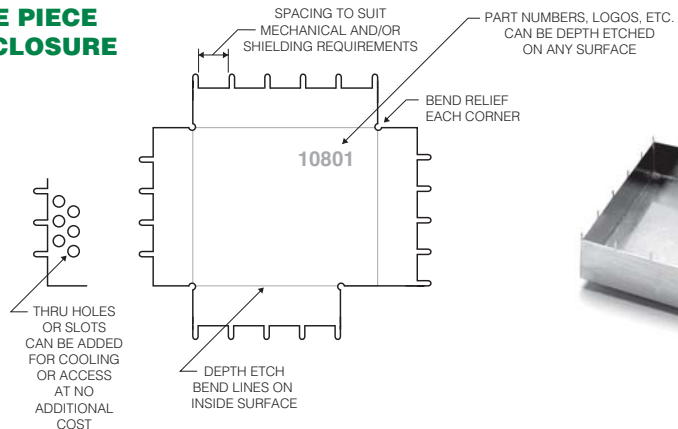

MOUNTING OPTIONS

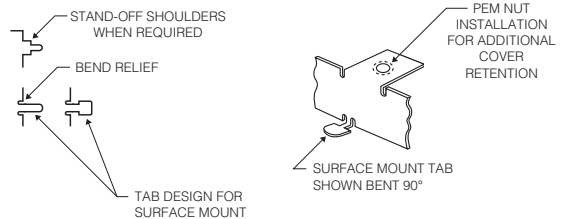

Metalized Fabric Gaskets



Tech-Etch metalized nylon fabric over polyurethane foam core gaskets are setting a new standard for shielding control. Nickel-plating over a highly conductive copper plated substrate provides the excellent electrical characteristics necessary for high attenuation shielding. Bonding the conductive substrate to the foam core assures self-termination of gaskets cut to length, while providing superior flexibility. RoHS compliance ensures that these gaskets are environmentally friendly.

Mounting

Stick-on Mounting uses double-sided pressure sensitive transfer tape for a fast, reliable installation (3M F9495LE non-conductive adhesive or equivalent). Apply only on a clean, oil-free surface and allow a 24-hour cure time.

Standard Profiles

Tech-Etch offers a wide range of standard profiles. If necessary, we can produce custom profiles to your specifications.

Shielding Effectiveness

(MIL-G-83528)

@ 30 MHz	98 dB
@ 100 MHz	113 dB
@ 300 MHz	127 dB
@ 500 MHz	113 dB
@ 800 MHz	113 dB
@ 900 MHz	123 dB
@ 1 GHz	114 dB
@ 2 GHz	124 dB
@ 4 GHz	122 dB
@ 6 GHz	122 dB
@ 8 GHz	124 dB
@ 10 GHz	134 dB

Specifications

Tolerances: Height and Width: ± 0.020 in. < .100, ± 0.030 > .100
Foam Core: Open-Cell Polyurethane Foam
Metalized Fabric: Nickel Plating Over Copper Substrate
Service Temperature: -40°F to 158°F (-40°C to 70°C)
Compression Set: (ASTM D3574) 2.6%
Compression Deflection: (ASTM D3574) 1.47 psi
Flammability Rating: UL 94 Rated
Surface Resistivity: (ASTM F390) <.02 Ohms

How To Order

2400 Series - Metalized Fabric - Elastomer Core

Example: Part number 2411-1011-0102-8.75 is nickel-plated copper over foam, cut to 8.75", UL 94 Rated, with pressure sensitive tape, in a rectangular configuration of .040" x .200". **The sequential number is assigned by the factory.**

2	4	X	1	-	Y	01	-	X	X	X	X	-	L	L	L	L
2400 SERIES								SEQUENTIAL (XXX)					LENGTH (LL.LL") Length of Cut Gasket			
								ADHESIVE (A) 0 No Adhesive 1 Pressure Sensitive								
								RATING 01 UL 94 Rated								
								FINISH (Y) 1 Nickel Over Copper 9 Other								
								CONDITION (C) 1* Cut To Length Maximum Length (84.00 Inches) <small>*Length in inches to be specified following the sequential number.</small>								
								CONFIGURATION (X) 1 Rectangular 4 C-Fold 7 Domed Shape 2 Square 5 Knife Edge 9 Other 3 D 6 Flat								

Note: For die-cut metalized gaskets refer to page 39 (2600 Series).

2400 Series - Standard Metalized Fabric Gaskets

Rectangular

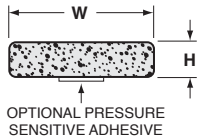

H. (in.)	W. (in.)	Part Number
.040	.120	2411 - 101A - 0100
.040	.157	2411 - 101A - 0101
.040	.200	2411 - 101A - 0102
.040	.275	2411 - 101A - 0141
.040	.395	2411 - 101A - 0103
.040	.500	2411 - 101A - 0204
.040	.710	2411 - 101A - 0187
.062	.170	2411 - 101A - 0165
.062	.200	2411 - 101A - 0105
.062	.300	2411 - 101A - 0142
.062	.500	2411 - 101A - 0104
.080	.160	2411 - 101A - 0143
.080	.275	2411 - 101A - 0106
.080	.400	2411 - 101A - 0107
.100	.080	2411 - 101A - 0177
.100	.375	2411 - 101A - 0206
.118	.157	2411 - 101A - 0178
.120	.150	2411 - 101A - 0144
.125	.250	2411 - 101A - 0108
.125	.500	2411 - 101A - 0109
.125	.700	2411 - 101A - 0145
.125	.750	2411 - 101A - 0208
.130	.190	2411 - 101A - 0110
.130	.380	2411 - 101A - 0146
.150	.375	2411 - 101A - 0147
.150	.500	2411 - 101A - 0193
.157	.315	2411 - 101A - 0148
.160	.200	2411 - 101A - 0167
.195	.500	2411 - 101A - 0198
.200	.315	2411 - 101A - 0190
.250	.375	2411 - 101A - 0111
.250	.500	2411 - 101A - 0112
.250	.750	2411 - 101A - 0149
.375	.500	2411 - 101A - 0113
.375	1.000	2411 - 101A - 0191

Square

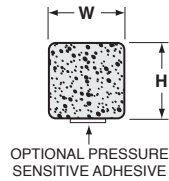

H. (in.)	W. (in.)	Part Number
.093	.093	2421 - 101A - 0199
.118	.118	2421 - 101A - 0114
.157	.157	2421 - 101A - 0168
.195	.195	2421 - 101A - 0115
.236	.236	2421 - 101A - 0116
.250	.250	2421 - 101A - 0117
.375	.375	2421 - 101A - 0118
.395	.395	2421 - 101A - 0119
.500	.500	2421 - 101A - 0120

D

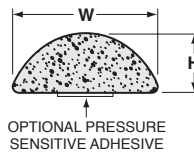

H. (in.)	W. (in.)	Part Number
.060	.150	2431 - 101A - 0122
.090	.090	2431 - 101A - 0123
.090	.150	2431 - 101A - 0150
.120	.150	2431 - 101A - 0124
.125	.090	2431 - 101A - 0151
.125	.250	2431 - 101A - 0125
.140	.250	2431 - 101A - 0126
.140	.375	2431 - 101A - 0163
.150	.150	2431 - 101A - 0152
.196	.315	2431 - 101A - 0153
.200	.190	2431 - 101A - 0154
.250	.250	2431 - 101A - 0127
.250	.375	2431 - 101A - 0128
.375	.500	2431 - 101A - 0155
.433	.158	2431 - 101A - 0186

C-Fold

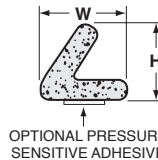

H. (in.)	W. (in.)	Part Number
.250	.250	2441 - 101A - 0137
.385	.420	2441 - 101A - 0138
.395	.430	2441 - 101A - 0139
.675	.590	2441 - 101A - 0140

Knife Edge

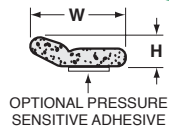

H. (in.)	W. (in.)	Part Number
.088	.455	2451 - 101A - 0196
.106	.445	2451 - 101A - 0156
.250	.750	2451 - 101A - 0157

Flat

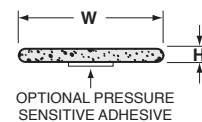

H. (in.)	W. (in.)	Part Number
.040	1.000	2461 - 101A - 0158
.040	1.650	2461 - 101A - 0169
.060	0.750	2461 - 101A - 0159
.060	1.000	2461 - 101A - 0160
.060	1.440	2461 - 101A - 0179
.080	0.830	2461 - 101A - 0161
.080	1.142	2461 - 101A - 0170
.100	1.200	2461 - 101A - 0171
.100	1.500	2461 - 101A - 0172
.118	2.165	2461 - 101A - 0189
.120	1.440	2461 - 101A - 0173
.125	1.615	2461 - 101A - 0162

Domed Shapes

Fig. A

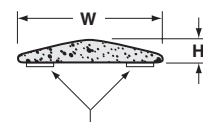
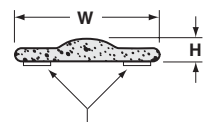
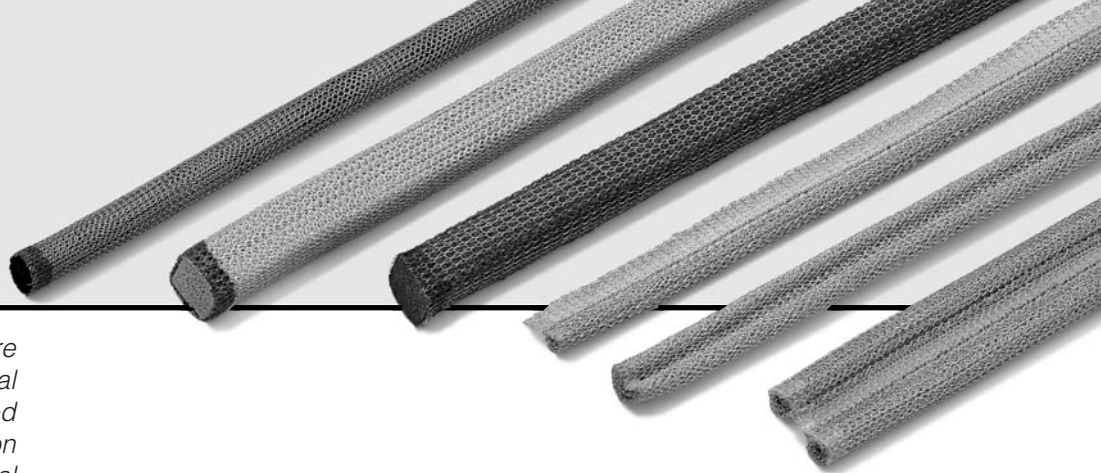

Fig. B



H. (in.)	W. (in.)	Part Number	Fig.
.080	.450	2471 - 101A - 0194	B
.080	.450	2471 - 101A - 0202	A
.080	.500	2471 - 101A - 0174	B
.080	.500	2471 - 101A - 0205	A
.080	.675	2471 - 101A - 0175	B
.100	.394	2471 - 101A - 0207	A
.120	.600	2471 - 101A - 0195	B

Mesh Gaskets



Tech-Etch manufactures knitted wire mesh, which can be used as economical gaskets for EMI shielding. All knitted mesh configurations are supplied on spools, coils or cut to length as individual gaskets with or without end seals. Standard profiles for a wide variety of applications are round, round with tail, double round with tail, half round (D) and rectangular.

Most profiles are available as all mesh and all are available with an elastomer core to enhance compression characteristics and increase the deflection range. Standard wire mesh materials are monel, TCS (tin plated copper clad steel) stainless steel and aluminum. Consult the factory for other materials. Wire selection should take into account attenuation potential, mechanical characteristics, and corrosion resistance.

Conductive Materials

Monel

The most commonly used for good conductivity, corrosion resistance and good mechanical characteristics. Not recommended for applications contacting aluminum.

Monel Wire Per QQ-N-281
Class A, 0.0045 in. dia.

TCS

Tin plated copper clad steel has similar characteristics to Monel, with improved shielding at lower frequencies but slightly lower corrosion resistance.

TCS Wire ASTM-B-520
0.0045 in. dia.

Aluminum

Aluminum wire is normally used only when galvanic compatibility with aluminum housing is required.

Aluminum Wire AMS 4182
Alloy 5056, 0.005 in. dia.

Silver / Monel

Silver/Monel is silver plated nylon filament with a fine strand of Monel wire knitted over a soft elastomer core to provide a very low compression force while achieving excellent attenuation values.

Core Materials

Standard core materials are available in neoprene (sponge and solid), silicone (sponge and solid), and polyurethane foam. Core materials should be selected for temperature, chemical resistance and mechanical characteristics.

See product sections for hollow elastomer core availability.

Neoprene

Neoprene rubber is an economical, general-purpose elastomer with good compression characteristics. It is available in solid and sponge and in hollow core cross sections.

Sponge ASTM D6576 Type II
Grade A (Formerly MIL-R 6130)
Temperature Range: -31° to 100° C

Solid MIL-R 6885 Class II, Grade 40
Temperature Range: -40° to 100° C

Silicone

Silicone rubber is noted for its retention of flexibility, resilience and tensile strength over a wide temperature range. Silicone is more resistant to cleaning solvents than neoprene.

Sponge AMS-3195
Temperature Range: -75° to 205° C

Solid A-A 59588 Class II
Grade 40 (Formerly ZZ-R-765)
Temperature Range: -60° to 260° C

Polyurethane Foam

Polyurethane Foam should be specified for light compression force applications. This material has good compression set characteristics and is available in rectangular and square solid cross sections.

Temperature Range: -40° to 121° C

End Seal Material

Cut to length gaskets are available with sealed ends to capture loose particles produced when the gaskets are cut.

End Seal 3M 1357 Adhesive
Dow Corning 3145RTV

Shielding Performance

Maximum attenuation for all gaskets is achieved as compression force increases. Care must be taken with mesh gaskets to avoid compression set, which will occur when the gasket is compressed beyond 25% of the free height. The use of elastomer cores will extend the operating range. In applications where the gasket is permanently installed between two surfaces, compression set can be tolerated.

EMI Shielding Performance

Material	H-Field 100kHz	E-Field 10MHz	P-Field 1GHz
BeCu	>110 dB	>110 dB	<110 dB
Monel	60 dB	>115 dB	95 dB
T.C.S.	80 dB	125 dB	100 dB
Aluminum	38 dB	100 dB	80 dB
Silver/Monel	60 dB	75 dB	70 dB

Materials Key

WIRE MESH MATERIALS KEY	
KNITTED WIRE MESH	
ELASTOMER	
ALUMINUM EXTRUSION	

Mounting Methods

Groove Mounting

Die-castings can be designed for groove mounting to provide good retention and to control the amount of compression.

Stick-On Mounting

All profiles except round can be mounted with double-sided pressure sensitive transfer tape for a fast, reliable installation. 3M F9469PC transfer tape may be used at ambient temperatures from -67°F to 300°F. Apply on clean, oil free surface, and allow a 24-hour cure time for maximum adhesion.

2000 Series Wire Mesh Mesh Core

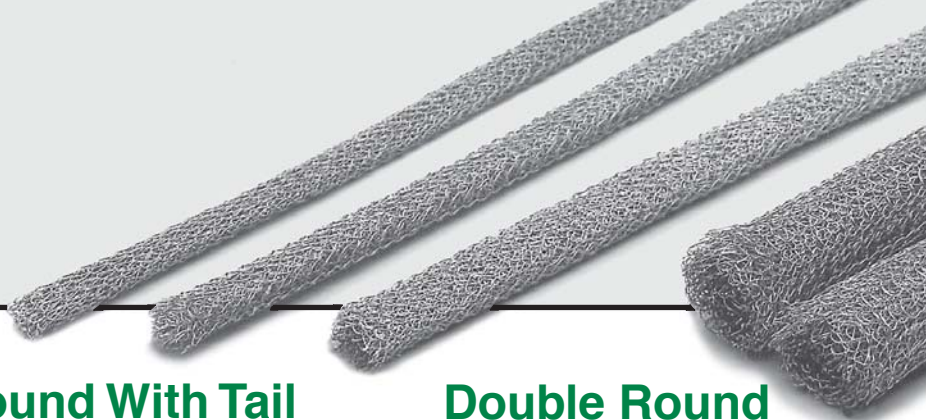

Rectangular

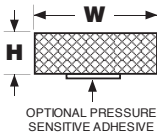

H (in.)	W (in.)	Part Number
.062	.062	201T - YY0A - 0001
.062	.125	201T - YY0A - 0005
.062	.156	201T - YY0A - 0018
.062	.188	201T - YY0A - 0011
.062	.250	201T - YY0A - 0016
.093	.093	201T - YY0A - 0002
.093	.125	201T - YY0A - 0006
.093	.188	201T - YY0A - 0012
.093	.250	201T - YY0A - 0003
.125	.125	201T - YY0A - 0007
.125	.188	201T - YY0A - 0009
.125	.375	201T - YY0A - 0004
.125	.250	201T - YY0A - 0010
.125	.500	201T - YY0A - 0013
.156	.125	201T - YY0A - 0008
.188	.188	201T - YY0A - 0014
.188	.250	201T - YY0A - 0017
.188	.500	201T - YY0A - 0038
.250	.250	201T - YY0A - 0015
.375	.375	201T - YY0A - 0021

Tolerances: Height and Width ±0.031 in.

Round With Tail

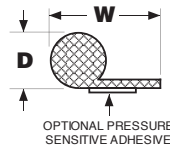

D (in.)	W (in.)	Part Number
.062	.375	203T - YY0A - 0040
.062	.500	203T - YY0A - 0041
.062	.625	203T - YY0A - 0042
.093	.500	203T - YY0A - 0043
.125	.375	203T - YY0A - 0044
.125	.500	203T - YY0A - 0045
.125	.625	203T - YY0A - 0046
.125	.750	203T - YY0A - 0047
.188	.500	203T - YY0A - 0048
.188	.625	203T - YY0A - 0049
.188	.750	203T - YY0A - 0050
.250	.500	203T - YY0A - 0051
.250	.625	203T - YY0A - 0052
.250	.750	203T - YY0A - 0053
.250	1.000	203T - YY0A - 0054

Tolerances: Diameter ±0.031 in.
Width ±0.031 in.

Double Round With Tail

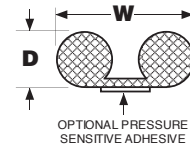

D (in.)	W (in.)	Part Number
.062	.375	204T - YY0A - 0055
.062	.500	204T - YY0A - 0056
.062	.625	204T - YY0A - 0057
.093	.500	204T - YY0A - 0058
.125	.375	204T - YY0A - 0059
.125	.500	204T - YY0A - 0060
.125	.625	204T - YY0A - 0061
.125	.750	204T - YY0A - 0068
.188	.625	204T - YY0A - 0062
.188	.750	204T - YY0A - 0063
.188	1.000	204T - YY0A - 0064
.250	.625	204T - YY0A - 0065
.250	.750	204T - YY0A - 0066
.250	1.000	204T - YY0A - 0067

Tolerances: Diameter ±0.031 in.
Width ±0.031 in.

Round

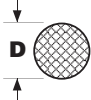

D (in.)	Part Number
.062	202T - YY00 - 0026
.093	202T - YY00 - 0027
.125	202T - YY00 - 0028
.156	202T - YY00 - 0029
.188	202T - YY00 - 0030
.250	202T - YY00 - 0031
.313	202T - YY00 - 0032
.375	202T - YY00 - 0033
.500	202T - YY00 - 0034
.563	202T - YY00 - 0035
.625	202T - YY00 - 0036
.750	202T - YY00 - 0037
1.000	202T - YY00 - 0038

Tolerance: Diameter ±0.031 in.

How To Order

2000 Series - Knitted Wire Mesh-Mesh Core

Example: Part number 2032-2000-0045-8.75 is monel wire, cut to 8.75" with no end seal, no adhesive, round with tail configuration, and .125" diameter x .500" wide. **Unless standard, the sequential number is assigned by the factory.**

2	0	X	T	-	Y	Y	0	A	-	X	X	X	X	-	L	L	L	L	
2000 SERIES								ADHESIVE (A)		SEQUENTIAL (XXXX)					LENGTH (LL.LL")				
								0 No Adhesive 1 Pressure Sensitive											Length of Cut Gaskets (Condition 1, 2 or 3 Only)
								MESH CORE (0)											
								WIRE (YY)											
								10 TCS 30 Aluminum 20 Monel 40 Stainless Steel 50 Other											
								CONDITION (T)											
								0 Continuous in Roll 3** Joined Ring Cut To Length 1* Cut To Length With End Seal 5 Other 2* Cut To Length Without End Seal											
								*Length in inches to be specified following the sequential number											
								**Circumference in inches to be specified following the sequential number											
								CONFIGURATION (X)											
								1 Rectangular 3 Round W/Tail 2 Round 4 Double Round W/Tail											

For material specifications and performance data see page 32.

FOR SIZES NOT SHOWN, PLEASE ASK!

2000 Series Wire Mesh Elastomer Core

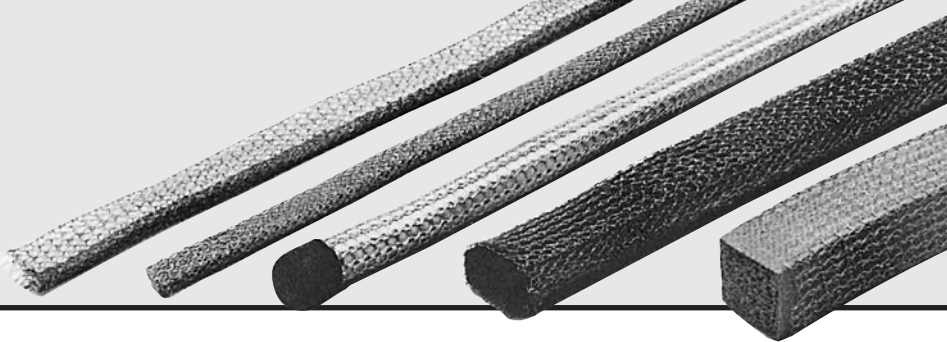

NOTE: Standard cross-sectional dimensions given are those of the elastomer and due allowance must be made for mesh thickness.

Rectangular

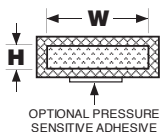

H (in.)	W (in.)	Part Number
.062	.250	201T - YNZA - 0016
.093	.125	201T - YNZA - 0006
.125	.125	201T - YNZA - 0007
.125	.156	201T - YNZA - 0008
.125	.188	201T - YNZA - 0009
.125	.250	201T - YNZA - 0010
.188	.188	201T - YNZA - 0013
.188	.250	201T - YNZA - 0005
.250	.250	201T - YNZA - 0018
.250	.500	201T - YNZA - 0020
.375	.250	201T - YNZA - 0019
.375	.500	201T - YNZA - 0022
.375	.625	201T - YNZA - 0023
.500	.500	201T - YNZA - 0024
.750	.500	201T - YNZA - 0025

Tolerances for Elastomer: Up to .0.375, ±0.031 in.; over 0.375 to 0.750, ±0.062 in.

Round

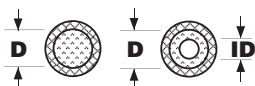

D (Core) (in.)	ID (Tube) (in.)	Part Number
.062	.032	202T - YNZO - 0026
.093		202T - YNZO - 0027
.125	.062	202T - YNZO - 0028
.156		202T - YNZO - 0029
.188	.125	202T - YNZO - 0030
.250	.170	202T - YNZO - 0031
.312	.188	202T - YNZO - 0032
.375	.250	202T - YNZO - 0033
.437	.312	202T - YNZO - 0034
.500	.375	202T - YNZO - 0035
.625	.437	202T - YNZO - 0036
.750		202T - YNZO - 0037

Tolerances for Elastomer: Up to 0.500 dia., ±0.031 in.; over 0.500 dia., ±0.047 in.

Round With Tail

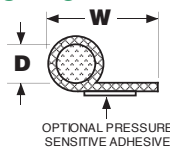

D (Core) (in.)	W (O/A) (in.)	Part Number
.125	.500	203T - YNZA - 0045
.125	.625	203T - YNZA - 0046
.125	.750	203T - YNZA - 0047
.188	.500	203T - YNZA - 0048
.188	.750	203T - YNZA - 0050
.188	1.250	203T - YNZA - 0055
.250	.500	203T - YNZA - 0051
.250	.625	203T - YNZA - 0052
.250	.750	203T - YNZA - 0053
.250	1.000	203T - YNZA - 0054

Tolerances for Width: Up to 1.00 in., ±0.062 in.; over 1.00 in., ±0.12 in.

D

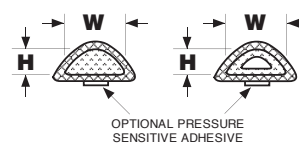

H (Core) (in.)	W (Core) (in.)	Part Number
.188	.250	206T - YNZA - 0010
.250	.375	206T - YNZA - 0020
.375	.500	206T - YNZA - 0030

Tolerances for Elastomer ±0.031 in.

Note: Round With Tail also available as **Double Round With Tail**. Order as 2040-YNZA-XXXX. For Width (W) and Depth (D), use sequential numbers from Mesh Core Double Round With Tail on page 33.

How To Order

2000 Series - Elastomer Core

Example: Part number 2020-2060-0028 a continuous roll of 0.125" diameter silicone tubing covered with two layers of monel mesh with no adhesive. **Unless standard, the sequential number is assigned by the factory.**

2	0	X	T	-	Y	N	Z	A	-	X	X	X	X	-	L	L	L	L	
2000 SERIES								SEQUENTIAL (XXXX)		ADHESIVE (A)					LENGTH (LL.LL")				
								0 No Adhesive		Length of Cut Gaskets (Condition 1, 2 or 3 Only)									
								1 Pressure Sensitive		ELASTOMER CORE (Z)									
										1 Neoprene Sponge									
										2 Neoprene Solid									
										3 Neoprene Hollow									
										4 Silicone Sponge									
										5 Silicone Solid									
										6 Silicone Hollow									
										7 Neoprene Sponge (UL94V-0)									
										8 Polyurethane Foam									
										NUMBER OF COVERS (N)									
										1 One 3 Three 5 Other									
										0 Two* 4 Four *Standard									
										WIRE (Y)									
										1 TCS 3 Aluminum 5 Other									
										2 Monel 4 Stainless Steel									
										CONDITION (T)									
										0 Continuous Roll 3** Joined Ring Cut To Length									
										1* Cut To Length With End Seal 5 Other									
										2* Cut To Length Without End Seal									
										*Length in inches to be specified following the sequential number									
										**Circumference in inches to be specified following the sequential number									
										CONFIGURATION (X)									
										1 Rectangular 4 Double Round W/Tail									
										2 Round 6 D Shape									
										3 Round W/Tail									

For material specifications and performance data see page 32.

FOR SIZES NOT SHOWN, PLEASE ASK!

2200 Series Silvershield



NOTE: Standard cross-sectional dimensions given are those of the elastomer and due allowance must be made for mesh thickness.

Rectangular

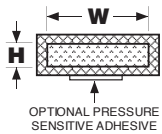

H (in.)	W (in.)	Part Number
.062	.250	221T - 11ZA - 0016
.125	.125	221T - 11ZA - 0007
.125	.156	221T - 11ZA - 0008
.188	.250	221T - 11ZA - 0005
.188	.125	221T - 11ZA - 0009
.188	.188	221T - 11ZA - 0013
.125	.250	221T - 11ZA - 0010
.250	.250	221T - 11ZA - 0018
.375	.250	221T - 11ZA - 0019
.250	.500	221T - 11ZA - 0020
.375	.500	221T - 11ZA - 0022
.500	.500	221T - 11ZA - 0024
.375	.625	221T - 11ZA - 0023
.750	.500	221T - 11ZA - 0025

Tolerances for Elastomer: Up to .0375, ±0.031 in.; over 0.375 to 0.750, ±0.062 in.

Round

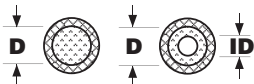

D (Core) (in.)	ID (Tube) (in.)	Part Number
.062	.032	222T - 11Z0 - 0026
.093		222T - 11Z0 - 0027
.125	.062	222T - 11Z0 - 0028
.156		222T - 11Z0 - 0029
.188	.125	222T - 11Z0 - 0030
.250	.170	222T - 11Z0 - 0031
.312	.188	222T - 11Z0 - 0032
.375	.250	222T - 11Z0 - 0033
.437	.312	222T - 11Z0 - 0034
.500	.375	222T - 11Z0 - 0035
.625	.437	222T - 11Z0 - 0036
.750		222T - 11Z0 - 0037

Tolerances for Elastomer: Up to 0.500 dia., ±0.031 in.; over 0.500 dia., ±0.047 in.

Round With Tail

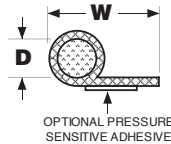

D (Core) (in.)	W (O/A) (in.)	Part Number
.125	.500	223T - 11ZA - 0045
.125	.625	223T - 11ZA - 0046
.125	.750	223T - 11ZA - 0047
.188	.500	223T - 11ZA - 0048
.188	.750	223T - 11ZA - 0050
.188	1.250	223T - 11ZA - 0055
.250	.500	223T - 11ZA - 0051
.250	.625	223T - 11ZA - 0052
.250	.750	223T - 11ZA - 0053
.250	1.000	223T - 11ZA - 0054

Tolerances for Width: Up to 1.00 in., ±0.062 in.; over 1.00 in., ±0.12 in.

D

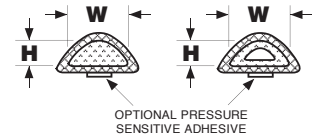

H (Core) (in.)	W (Core) (in.)	Part Number
.188	.250	226T - 11ZA - 0010
.250	.375	226T - 11ZA - 0020
.375	.500	226T - 11ZA - 0030

Tolerances for Elastomer ±0.031 in.

Note: Round With Tail also available as **Double Round With Tail**. Order as 2240-11ZT-XXXX. For Width (W) and Depth (D), use sequential numbers from Mesh Core Double Round With Tail on page 34.

How To Order

2200 Series - Silvershield Elastomer Core

Example: Part number 2211-1181-0010-5.50 is 0.125" x 0.250" rectangular polyurethane foam covered with one layer of silver/monel mesh with adhesive mounting cut to 5.50" length with end seal of 3M 1357 adhesive. **Unless standard, the sequential number is assigned by the factory.**

2200 SERIES	SEQUENTIAL (XXXX)	ADHESIVE (A)	ELASTOMER CORE (Z)	NUMBER OF COVERS (1)	WIRE (1)	CONDITION (T)	CONFIGURATION (X)											
22	11	X	T	-	1	1	Z	A	-	X	X	X	X	-	L	L	L	L
		0 No Adhesive 1 Pressure Sensitive	1 Neoprene Sponge 3 Neoprene Hollow 4 Silicone Sponge 6 Silicone Hollow 7 Neoprene Sponge (UL94V-0) 8 Polyurethane Foam	1 One (Standard)	1 Silver Plated Nylon/Monel	0 Continuous Roll 1* Cut To Length With End Seal 2* Cut To Length Without End Seal 5 Other	1 Rectangular 2 Round 3 Round W/Tail 4 Double Round W/Tail 6 D Shape											

*Length in inches to be specified following the sequential number

For material specifications and performance data see page 32.

FOR SIZES NOT SHOWN, PLEASE ASK!

Standard Connector & Waveguide Gaskets

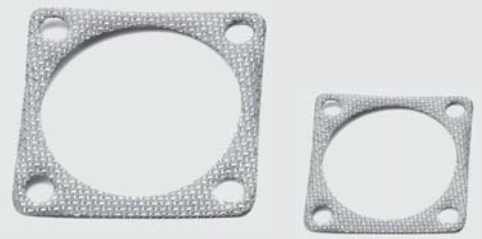

Tech-Etch offers a wide range of standard Connector and Wave Guide Gaskets in a variety of materials for the military and commercial markets. In addition to the standard gaskets, Tech-Etch offers custom designed Connector Gaskets using low cost photoetching and secondary forming to avoid expensive tooling for prototypes and moderate volumes.

Conductive Elastomers

A wide range of products is available in a variety of materials. The most common configurations are shown. For other configurations a detailed drawing and specifications are required. These gaskets are available in conductive particles in elastomer Series 1000, oriented wire in elastomer Series 4000, monel foil in elastomer Series 5000 and aluminum mesh in elastomer Series 5500. Material specifications and shielding performance may be found on page 32.

CONNECTOR GASKETS

Connector gaskets are available from stock in a variety of materials and configurations. For details of the materials and shielding performance refer to the page indicated in the note below.

AN Connector Gaskets (Conductive Elastomers)

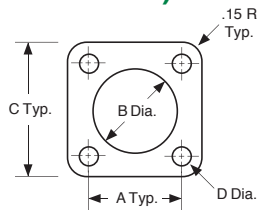

Shell Size	A	B	C	D	Seq. Part No.
8	.594	.500	.875	.172	2008
10	.719	.625	1.000	.172	2010
12	.813	.750	1.094	.172	2012
14	.906	.875	1.188	.172	2014
16	.969	1.000	1.281	.172	2016
18	1.063	1.125	1.375	.203	2018
20	1.156	1.250	1.500	.203	2020
22	1.250	1.375	1.625	.203	2022
24	1.375	1.500	1.750	.203	2024
28	1.563	1.750	2.000	.203	2028
32	1.750	2.000	2.250	.219	2032
36	1.938	2.188	2.500	.219	2036
40	2.188	2.438	2.750	.219	2040
44	2.375	2.781	3.000	.219	2044
48	2.625	3.031	3.250	.219	2048

Note: AN Connector Gaskets and D-Connector Gaskets are available in the following materials:

- Series 1000** (conductive media on silicone elastomer) page 40.
- Series 4000** (oriented aluminum or monel wires in silicone elastomer) page 42.
- Series 5000** (expanded monel or aluminum foil in silicone elastomer) page 44.
- Series 5500** (woven aluminum wire mesh in silicone or neoprene elastomer) pg.45.

Metalized Fabric

Standard D Connector Gaskets are described below and on page 39. Custom designed gaskets using metalized fabric wrapped around a polyurethane foam core are fabricated using low cost rule-dies. The conductive fabric is bonded to the core assuring self-termination on all exposed edges.

Beryllium Copper / Stainless Steel

"D" Connector Shield Gaskets provide shielding for most 9 pin through 50 pin connectors. Independent finger design with a free height of .025 for maximum surface contact provides high attenuation values with low compression forces. They are available in beryllium copper and stainless steel and can be plated in any of the finishes listed on page 6. See page 3 for material specifications.

D-Connector Gaskets

(Conductive Elastomers & Metalized Fabric)

D-Connector gaskets provide shielding for most 9 pin through 50 pin connectors and are available from stock in a variety of materials. For details on Conductive Elastomer materials and shielding performance, refer to the page indicated in the note below. For details on Metalized Fabric 2640 Series standard gaskets, refer to page 30 for specifications and page 39 for ordering information.

Use this chart and drawing to determine the sequential number. Note: Standard 2600 Series Metalized Fabric gaskets have square corners and come with pressure sensitive tape.

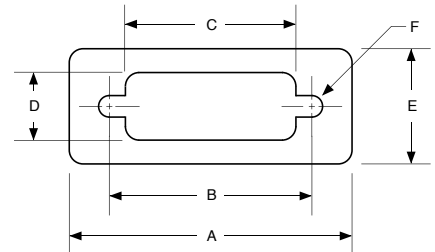

No. Pins	A	B	C	D	E	F	Seq. Part No.
9	1.313	.98	.78	.44	.750	.07 R.	3009
15	1.641	1.31	1.11	.44	.750	.07 R.	3015
25	2.188	1.85	1.65	.44	.750	.07 R.	3025
37	2.829	2.50	2.29	.44	.750	.07 R.	3037
50	2.740	2.41	2.11	.55	.880	.07 R.	3050

How To Order

Elastomer AN & D-Connector Gaskets

For the Elastomer Series desired, refer to the appropriate page listed at the left to specify the material and thickness. The sequential number after the material codes completes the part number. Example: Part number 5072-2050-2012 is Monoshield .020 inches thick for shell size 12 connector.

Metalized Fabric D-Connector Gaskets

Use the sequential number from the chart above to complete the part number on page 39. All standard Metalized Fabric D Connectors have Nickel over Copper Finish (1), Foam Core (1), and Pressure Sensitive Adhesive (1). Example: Part number 2640-1111-3015-040 is a 15 pin D Connector gasket.

Standard Connector & Waveguide Gaskets



D-Connector Gaskets (Beryllium Copper / Stainless Steel)

D-Connector Gaskets provide shielding for most 9 pin through 50 pin connectors. Independent finger design with free height of .025" for maximum surface contact provides high attenuation values with low compression forces. D-Connector Gaskets are available from stock in beryllium copper and stainless steel and can be plated in any of the finishes listed on page 6. For details of the materials, refer to page 3.

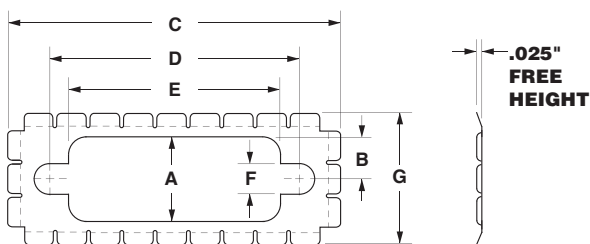

Gasket	A	B	C	D	E	F	G
9 Pin - Config. 1	.44	.22	1.41	.98	.78	.16	.69
9 Pin - Config. 2	.35	.18	1.41	.98	.78	.16	.69
15 Pin - Config. 1	.44	.22	1.74	1.31	1.11	.16	.69
15 Pin - Config. 2	.35	.18	1.74	1.31	1.11	.16	.69
25 Pin - Config. 1	.44	.22	2.28	1.85	1.65	.16	.69
25 Pin - Config. 2	.35	.18	2.28	1.85	1.65	.16	.69
37 Pin - Config. 1	.44	.22	2.93	2.50	2.29	.16	.69
37 Pin - Config. 2	.35	.18	2.93	2.50	2.29	.16	.69
50 Pin - Config. 1	.55	.28	2.84	2.41	2.20	.16	.80
50 Pin - Config. 2	.45	.23	2.84	2.41	2.20	.16	.80

How To Order

Metal D-Connector Gaskets

Example: Part number 25D12-02 is a 25-pin D-Connector Gasket made from Beryllium Copper with a clean and bright finish.

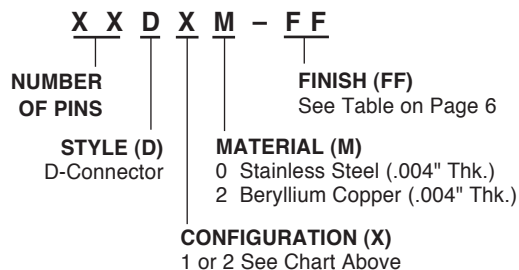

Waveguide Gaskets (Supershield Conductive Elastomer)

Waveguide gaskets are available from stock in conductive elastomer materials consisting of a silicone binder and a variety of conductive particles. For details of the materials and performance data refer to page 32.

Waveguide Gaskets For Plain Flanges Standard Die Cut Sizes

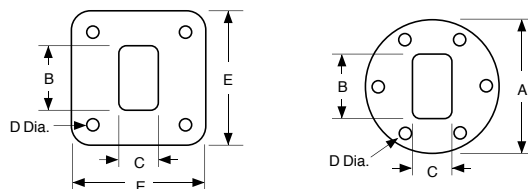

U.S. U.G.	W.G.	I.E.C.	W.R.	A	B	C	D	E	Seq. No.
-	10	R32	284	5.857	2.878	1.372	0.274	-	1010
53/U	-	-	-	5.312	2.878	1.372	0.281	-	1011
149A/U	12	R48	187	3.625	1.904	0.904	0.219	-	1012
344/U	14	R70	137	3.125	1.404	0.654	0.219	-	1014
39/U	16	R100	90	-	0.932	0.432	0.187	1.625	1016
419/U	18	R140	62	-	0.654	0.342	0.163	1.312	1018
595/U	20	R220	42	-	0.452	0.202	0.135	0.875	1020
599/U	22	R320	28	-	0.312	0.172	0.135	0.750	1022

Note: Waveguide gaskets are available only in the Supershield 1000 Series materials.

How To Order

Supershield Waveguide Gaskets

Refer to page 40 to select the material required. The sequential number after the material codes completes the part number. Example: Part number 1052-0250-1016 is 1000 Series Supershield, standard die cut Waveguide, .020" thick, 50 durometer, 39/U model.

1000 Series Supershield

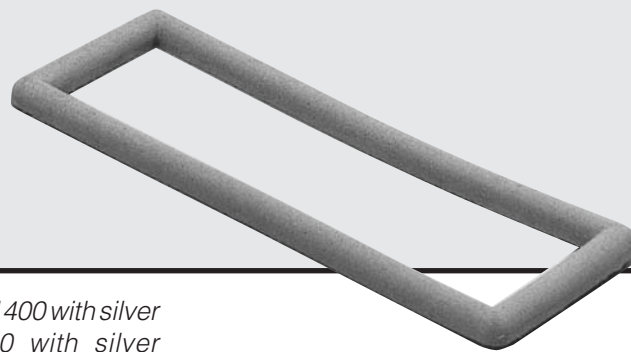

Supershield is a silicone elastomer filled with conductive metal particles to provide high shielding effectiveness and an environmental seal.

The Supershield family uses eight basic conducting media: Supershield 100 with carbon, Supershield 200 with nickel graphite, Supershield 300 with silver

(low density), Supershield 400 with silver nickel, Supershield 500 with silver aluminum, Supershield 600 with silver plated glass, Supershield 700 with pure silver, and Supershield 800 with silver-plated copper.

Values other than Specific Gravity were determined at the indicated durometer

compound. Material specifications (with the exception of specific gravity) may vary at other durometers.

Supershield can be supplied in a variety of sizes, standard extrusion sections, or as standard or custom die-cut gaskets.

Material Specifications

Per MIL-DTL-83528

Series	Carbon 100	Nickel Graphite 200	Nickel Graphite 200(FL)	Silver Low D. 300	Silver Nickel 400	Silver Nickel 400(FL)	Silver Aluminum 500	Silver Aluminum 500(FL)	Silver Glass 600	Silver Glass 600(FL)	Silver Pure 700	Silver Pure 700(FL)	Silver Pure 700	Silver Copper 800	Silver Copper 800(FL)	Silver Copper 800	Silver Copper 800
Elastomer	Silicone	Silicone	Fluoro-silicone	Silicone	Silicone	Fluoro-silicone	Silicone	Fluoro-silicone	Silicone	Fluoro-silicone	Silicone	Fluoro-silicone	Silver Silicone	Silicone	Fluoro-silicone	Silicone	Silicone
Color	Black	Dark Gray	Dark Gray	Tan	Tan	Tan	Blue*	Blue*	Tan	Tan	Tan	Tan	Tan	Tan	Tan	Tan	Tan
Specific Gravity, gm/cc	1.2	1.95	1.95	1.7	4.0	4.4	2.0	2.0	1.9	1.9	3.5	4.0	4.0	3.5	4.0	4.8	3.5
Durometer Shore A	70	30-70	65	45	75	70	65	70	65	65	65	75	80	65	75	80	85
MIL-83528 Type	N/A	N/A	N/A	J	L	-	B	D	M	-	E	F	H	A	C	G	K
Volume Resistivity, Ohm-cm	7.0	0.1	0.1	0.01	0.005	0.012	0.008	0.012	0.006	0.006	0.002	0.002	0.005	0.004	0.01	0.007	0.005
Operating Temp.: Min C	-55°	-55°	-55°	-55°	-55°	-55°	-55°	-55°	-55°	-55°	-55°	-65°	-55°	-55°	-55°	-45°	-45°
Operating Temp.: Max C	200°	150°	150°	160°	125°	160°	160°	160°	160°	160°	160°	160°	160°	125°	125°	125°	125°
Compression Deflection % Min.	3.5	3.5	3.0	8.0	3.5	3.5	3.5	3.5	3.5	3.5	2.5	3.5	2.5	3.5	3.5	2.5	2.5
Tensile Strength, P.S.I.	650	150	150	150	200	180	200	180	200	200	300	250	400	200	180	600	400
Elongation % Min.	100%	100%	100%	50%	100%	60%	100%	60%	100%	100%	200%	100%	90%	100%	100%	20%	100%
Elongation % Max.	-	-	-	250%	300%	260%	300%	260%	300%	300%	500%	300%	290%	300%	300%	N/A	300%
Compression Set %	40	35	25	35	32	30	32	30	30	30	45	60	60	32	35	N/A	35
Tear Strength lb./in.	40	40	35	20	30	35	30	35	30	30	50	40	60	25	35	70	40
Shielding Effectiveness (100 Mhz)	80	100	100	100	120	120	120	120	100	100	120	120	120	120	120	120	120
Shielding Effectiveness (500 Mhz)	80	100	100	100	120	120	120	120	100	90	120	120	120	120	120	120	120
Shielding Effectiveness (2 Ghz)	60	100	100	90	120	115	115	115	90	90	120	120	120	120	120	120	120
Shielding Effectiveness (10 Ghz)	50	100	100	90	110	110	115	115	90	90	120	120	120	120	115	120	120

* May also be special ordered in Tan.

Note: Add "FL" to the end of the Part Number for Fluorosilicone. Values other than specific gravity were determined with indicated durometers. Other durometers are available but may alter values.

Sheet Materials

Sheet Sizes

L	W	Sequential #
10.00" x 10.00"		0002
12.00" x 12.00"		0003
10.00" x 20.00"		0004
12.00" x 18.00"		0001
15.00" x 20.00"		0005
17.80" x 20.50"		0006

Sheet Thicknesses

.020" Thick
.030" Thick
.032" Thick
.040" Thick
.060" Thick
.062" Thick
.093" Thick
.125" Thick

FOR SIZES NOT SHOWN, PLEASE ASK!

1000 Series Supershield

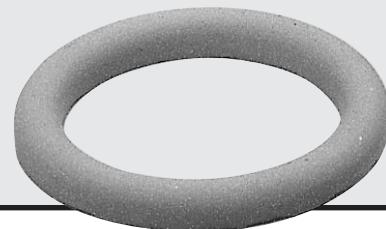

Extrusions

Round



D (Dia.)	Sequential #	D (Dia.)	Sequential #
0.040	1010	0.125	1005
0.053	1011	0.130	1015
0.062	1001	0.139	1006
0.070	1002	0.150	1016
0.080	1012	0.160	1007
0.093	1003	0.188	1008
0.103	1004	0.216	1017
0.112	1013	0.250	1009
0.119	1014		

Solid "D"

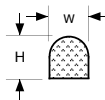

H	W	Sequential #
0.064	0.055	3041
0.068	0.062	3031
0.078	0.094	3032
0.089	0.078	3033
0.094	0.094	3042
0.100	0.062	3034
0.110	0.150	3035
0.131	0.122	3043
0.136	0.124	3036
0.156	0.118	3037
0.156	0.156	3044
0.175	0.178	3038
0.188	0.188	3039
0.250	0.250	3040

Rectangular Solid

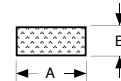

A	B	Sequential #
0.032	0.032	6061
0.060	0.080	6062
0.063	0.042	6063
0.095	0.062	6064
0.120	0.075	6065
0.125	0.062	6066
0.156	0.062	6067
0.250	0.062	6068
0.500	0.075	6069
0.500	0.125	6070
0.500	0.188	6071
0.750	0.062	6072
0.880	0.062	6073
1.000	0.250	6074
1.180	0.062	6075

Hollow Round

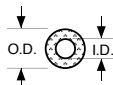

O.D. (in.)	I.D. (in.)	Sequential #
0.070	0.025	2026
0.093	0.035	2027
0.103	0.040	2028
0.125	0.045	2029
0.125	0.062	2021
0.156	0.050	2022
0.177	0.079	2030
0.250	0.125	2023
0.312	0.192	2031
0.375	0.250	2025
0.437	0.250	2032

Hollow "D"

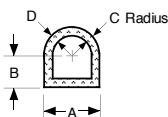

A	B	C	D	Sequential #
0.156	0.045	0.078	0.045	4041
0.156	0.078	0.078	0.045	4042
0.187	0.093	0.093	0.050	4043
0.250	0.125	0.125	0.065	4044
0.312	0.156	0.156	0.062	4045
0.487	0.080	0.244	0.080	4048

Channel

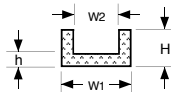

H	h	W1	W2	Sequential #
0.100	0.033	0.100	0.034	5051
0.110	0.050	0.126	0.026	5052
0.156	0.047	0.156	0.062	5053
0.156	0.075	0.175	0.047	5054
0.225	0.075	0.126	0.020	5057
0.235	0.115	0.327	0.062	5058

How To Order

1000 Series - Supershield

Example: Part number 1016-0650-0041 is 1000 Series Supershield with silver plated glass conductive particles in .06 in. thick sheet with a 50 durometer hardness. **Unless standard, the sequential number is assigned by the factory.**

1 0 X X - Y Y Z Z - X X X X - FL 1000 SERIES	SEQUENTIAL (XXXX)	DUROMETER (ZZ) 40 Durometer 65 Durometer 45 Durometer 70 Durometer 50 Durometer 75 Durometer 60 Durometer 80 Durometer	FLUROSILICONE Add "FL" if desired.
		SHEET THICKNESS (YY) 00 Non-sheet 06 .060" Thick 02 .020" Thick 09 .093" Thick 03 .030" Thick 12 .125" Thick 04 .040" Thick 32 .032" Thick 62 .062" Thick	
		CONDUCTING MEDIA (X) 1 Carbon (100) 2 Nickel Graphite (200) 3 Silver Low Density (300) 4 Silver Nickel (400) 5 Silver Aluminum (500) 6 Silver Plated Glass (600) 7 Pure Silver (700) 8 Silver Plated Copper (800) 9 Other	
		CONFIGURATION (X) 1 Sheet 4 Fabricated Part (Custom) 2 Extruded Strip 5 Standard Die Cut Connector or Waveguide 3 Molded	

FOR SIZES NOT SHOWN, PLEASE ASK!



4000 Series Multishield

Multishield is a composite material containing excellent shielding with an efficient environmental seal. The material is manufactured with a matrix of wires embedded in silicone rubber and aligned perpendicular to the contact surfaces. Multishield is available in strips up to 5/8 in. wide, sheets up to 9 in. wide, custom gaskets and standard gaskets.

Application Notes

Adhesive Mounting

Multishield can be bonded to sheet metal using a thin film of RTV 3145 (or equivalent) or 3M 950 pressure sensitive adhesive. Pressure must be applied to the bond for the duration of the adhesive cure time to assure good contact of the wires to metal.

Die Cut gaskets

Custom gaskets can be fabricated from solid or sponge multishield using inexpensive rule dies. See Fig. 1 for tolerancing and design guides. For standard product connector and waveguide gaskets, see page 37.

Picture Frame Gaskets

Picture frame gaskets can be fabricated from solid or sponge multishield strip material. Corner joints are bonded with RTV 3145. See Fig. 1 below for tolerances and design guides.

Compression Stops

Compression stops are recommended to control the amount of compression at assembly and to prevent excess compression at the fastener locations. Compression stops are available in stainless steel or aluminum. See Fig. 2 for design guides.

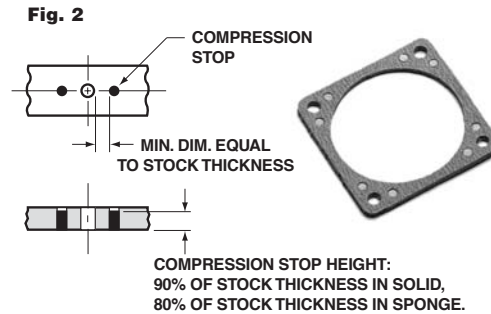

Material Specifications

Solid Silicone	A-A-59588, Class II, Grade 40 (Formerly ZZ-R-765)
Temperature Range	-60°C to 260°C
Sponge Silicone	AMS-3195
Temperature Range	-75°C to 205°C
Aluminum Wire	AMS 4182, Alloy 5056
Monel Wire	QQ-N-281 Class A
Wire Density / In. ²	
Silicone Solid	900 ±15%
Silicone Sponge	600 ±15%
Seal	Waterproof

EMI Shielding Performance

Monel Wire	H-Field 100kHz	E-Field 10MHz	P-Field 1GHz
Sponge	60 dB	130 dB	105 dB
Solid	75 dB	130 dB	110 dB

Sheet Materials

Width (in.)	Thick (in.)	Part Number
3.0	.032	4010 - YYZA - 0062
4.5	.032	4010 - YYZA - 0063
6.0	.032	4010 - YYZA - 0064
7.5	.032	4010 - YYZA - 0065
9.0	.032	4010 - YYZA - 0066
3.0	.045	4010 - YYZA - 0001
4.5	.045	4010 - YYZA - 0002
6.0	.045	4010 - YYZA - 0003
7.5	.045	4010 - YYZA - 0004
9.0	.045	4010 - YYZA - 0005
3.0	.062	4010 - YYZA - 0006
4.5	.062	4010 - YYZA - 0007
6.0	.062	4010 - YYZA - 0008
7.5	.062	4010 - YYZA - 0009
9.0	.062	4010 - YYZA - 0010
3.0	.093	4010 - YYZA - 0011
4.5	.093	4010 - YYZA - 0012
6.0	.093	4010 - YYZA - 0013
7.5	.093	4010 - YYZA - 0014
9.0	.093	4010 - YYZA - 0015
3.0	.125	4010 - YYZA - 0016
4.5	.125	4010 - YYZA - 0017
6.0	.125	4010 - YYZA - 0018
7.5	.125	4010 - YYZA - 0019
9.0	.125	4010 - YYZA - 0020
3.0	.156	4010 - YYZA - 0059
3.0	.188	4010 - YYZA - 0058

FOR SIZES NOT SHOWN, PLEASE ASK!

Thickness Tolerance Sheet & Strip Material

.032 in. - .045 in.	+ .010 - .005
.062 in. - .250 in.	± .010

Fig. 1

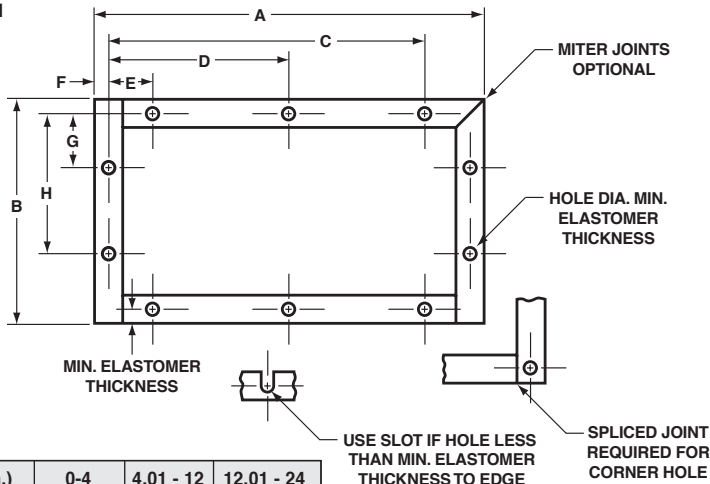

Length (in.)	0-4	4.01 - 12	12.01 - 24
A, B	±.020	±.031	±.040
C, D, E, F, G, H	±.010	±.015	±.020

See next page for How To Order.

4000 Series Multishield

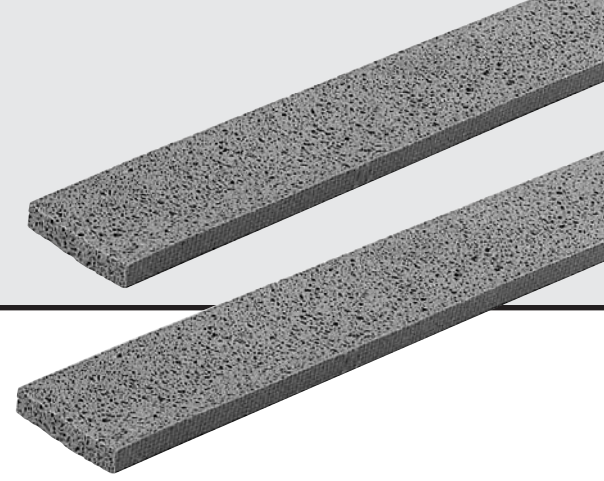

Strip Materials

Width (in.)	Thick (in.)	Part Number
.125	.032	4020 - YYZA - 0070
.188	.032	4020 - YYZA - 0071
.250	.032	4020 - YYZA - 0072
.313	.032	4020 - YYZA - 0073
.125	.045	4020 - YYZA - 0074
.188	.045	4020 - YYZA - 0075
.250	.045	4020 - YYZA - 0076
.313	.045	4020 - YYZA - 0077
.375	.045	4020 - YYZA - 0078
.500	.045	4020 - YYZA - 0079
.625	.045	4020 - YYZA - 0080
.188	.062	4020 - YYZA - 0022
.250	.062	4020 - YYZA - 0023
.313	.062	4020 - YYZA - 0024
.375	.062	4020 - YYZA - 0025
.500	.062	4020 - YYZA - 0026
.625	.062	4020 - YYZA - 0027
.125	.094	4020 - YYZA - 0028
.188	.094	4020 - YYZA - 0029
.250	.094	4020 - YYZA - 0030
.313	.094	4020 - YYZA - 0031
.375	.094	4020 - YYZA - 0032
.500	.094	4020 - YYZA - 0033
.625	.094	4020 - YYZA - 0034
.125	.125	4020 - YYZA - 0035
.188	.125	4020 - YYZA - 0036
.250	.125	4020 - YYZA - 0037
.313	.125	4020 - YYZA - 0038
.375	.125	4020 - YYZA - 0039
.500	.125	4020 - YYZA - 0040
.625	.125	4020 - YYZA - 0041
.125	.156	4020 - YYZA - 0042
.125	.188	4020 - YYZA - 0043
.188	.188	4020 - YYZA - 0044
.250	.188	4020 - YYZA - 0045
.313	.188	4020 - YYZA - 0046
.375	.188	4020 - YYZA - 0047
.500	.188	4020 - YYZA - 0048
.625	.188	4020 - YYZA - 0049
.125	.250	4020 - YYZA - 0050
.188	.250	4020 - YYZA - 0051
.250	.250	4020 - YYZA - 0052
.313	.250	4020 - YYZA - 0053
.375	.250	4020 - YYZA - 0054
.500	.250	4020 - YYZA - 0055
.625	.250	4020 - YYZA - 0056
.750	.125	4020 - YYZA - 1017

**FOR SIZES NOT SHOWN,
PLEASE ASK!**

How To Order Sheet

By part number in feet, usually supplied in lengths of 3 feet (approximately) or joined multiples.

Strip

Use part number listed in Strip Materials box and specify number of feet needed. Standard strip length is 3 feet. Bonded, continuous lengths are available on special order.

4000 Series - Multishield

Example: Part number 4030-2020-0310 is Silicone solid Monel Multishield with no adhesive, fabricated to customer's requirements of thickness and outline. **Unless standard, the sequential number is assigned by the factory.**

4 0 X X - Y Y Z A - X X X X 4000 SERIES	Y Y Z A WIRE TYPE (Z) 2 Monel 3 Aluminum	X X X X SEQUENTIAL (XXXX) ADHESIVE (A) 0 No Adhesive 1 Pressure Sensitive	MAT'L THICK 032 = .032" For 4040 Standard Connectors Only
---	---	---	---

ELASTOMER (YY)
 20 Silicone Solid
 50 Silicone Sponge

CONFIGURATION (XX)
 10 Sheet
 20 Strip
 30 Custom Part
 40 Standard Die-Cut Connector or Waveguide

For material specifications and performance data refer to page 32.

Custom Gaskets

Multishield die-cut gaskets, like those pictured here, are available in both standard and custom configurations. See page 37 for standard gaskets.

Strip Width Tolerance		
Width	Solid	Sponge
Up to .250 in.	±0.015	±0.031
.250 in. to .375 in.	±0.031	±0.031
.375 in. to .750 in.	±0.031	±0.046
.750 in. to 1.000 in.	±0.046	±0.062



5000 Series Monoshield

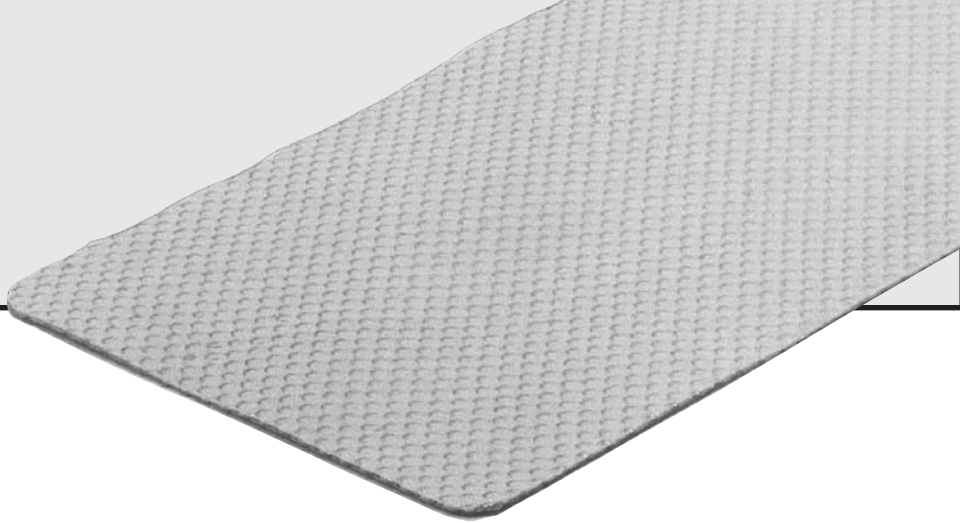

Monoshield is intended for applications where the gasket is limited to 0.02 in. thickness and gap irregularities do not exceed 0.003 in. The material consists of a fine monel or aluminum which is expanded (as per MIL-S-46044) and impregnated with a 50 durometer silicone rubber. The manufacturing process exposes approximately 225 points of contact per square inch to provide an efficient EMI shield with a pressure seal good up to 50 PSI between mating surfaces. These gaskets should not be reused after having been compressed.

Monoshield can be supplied with or without silicone impregnation in sheets or die cut gaskets. For custom die cut gaskets, use the guide in Fig. 1.

Standard Gaskets

Please refer to the Standard Product Connector and Waveguide Gaskets Section on page 37.

Material Specifications

Expanded Monel	QQ-N-281
Expanded Aluminum	QQ-A-250
Solid Silicone Elastomer	A-A-59588, Class II, Grade 50 (Formerly ZZ-R-765)
Contacts (approx.)	225/inch ²
Temperature Range	-60 to 260°C

EMI Shielding Performance

	H-Field 100kHz	E-Field 10MHz	P-Field 1GHz
Monoshield	55 dB	>120 dB	85 dB

Standard Sheet Sizes

Elastomer	Thickness x Width	Part Number
None	.020 in. x 12.0 in.	5012-2000-0001
None	.030 in. x 12.0 in.	5013-2000-0001
Silicone (solid)	.020 in. x 12.0 in.	5012-2050-0001
Silicone (solid)	.030 in. x 12.0 in.	5013-2050-0001

Thickness tolerances all types ±0.004 in.
Lengths up to 25 ft.

FOR SIZES NOT SHOWN, PLEASE ASK!

How To Order

5000 Series - Monoshield

Example: Part number 5012-2050-0110 is .020 thick silicone (solid) 5000 Series Monoshield with monel expanded metal die-cut to customer requirements. **Unless standard, the sequential number is assigned by the factory.**

5	0	X	T	-	Y	Y	Z	Z	-	X	X	X	X
5000 SERIES					ELASTOMER (ZZ)		Elastomer (ZZ)			SEQUENTIAL (XXXX)			
					Metal (YY)		Metal (YY)						
					THICKNESS (T)		Thickness (T)						
					CONFIGURATION (X)		Configuration (X)						

00 None
50 Silicone (solid)

20 Monel
30 Aluminum

2 .020 in. Thick
3 .030 in. Thick

1 Sheet (12.0 in. wide)
3 Fabricated Part (Custom)
7 Standard Die Cut Connector or Waveguide

Fig. 1

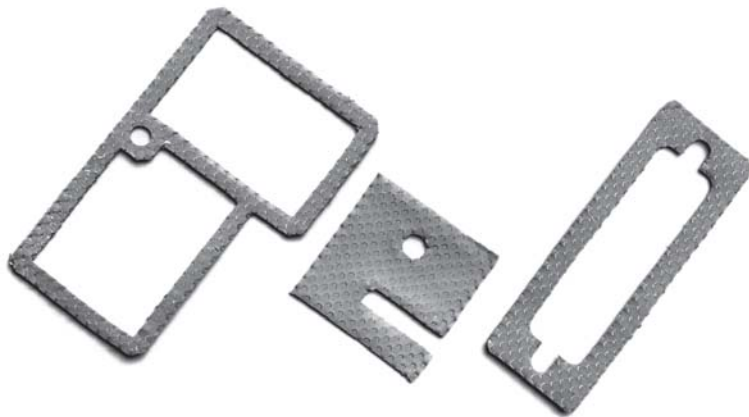
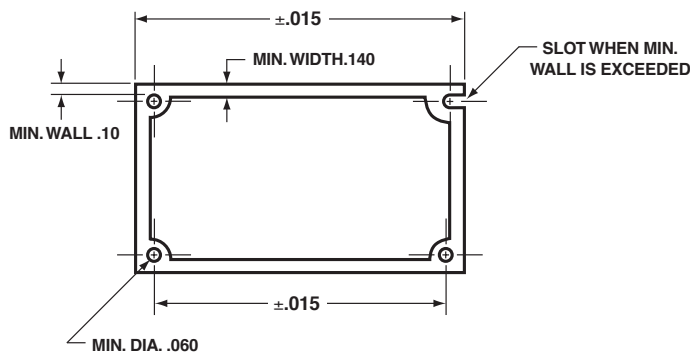

9000 Series Trimshield

Trimshield is a composite material made from resilient knitted wire mesh strips which are retained in an aluminum extrusion. It is ideal for use when a rigid gasket is required. The aluminum extrusion acts as a compression stop for the mesh to minimize compression set. Neoprene or silicone sponge may be used for an environmental seal.

Trimshield Strips can be supplied in lengths of up to approximately eight feet. The knitted mesh EMI portion diameter may vary from 0.125 to 0.625 inches. Elastomer/knitted mesh combination should be used for the lower compression force gaskets and to achieve minimum compression set. The extrusion itself can be drilled or punched to suit your specific requirements.

Applications range from small equipment gaskets to seals for personnel access doors.

Welded and Drilled Frames

Trimshield is supplied complete with welded/drilled/packed frames, fitted with mesh/mesh-elastomer gasket and a dust seal ready for easy installation. The dust seal is carefully mitred, with no ragged ends to result in hard-to-compress corners.

Mesh and Environmental Seals

Trimshield is available with any of the mesh configurations offered, in addition to a wide range of environmental seal materials.

Mounting Holes

Frames and strips can be ordered with mounting holes to customer specifications. Locations should be dimensioned from the edge of the extrusion. Welded corners provide dust tight seal.

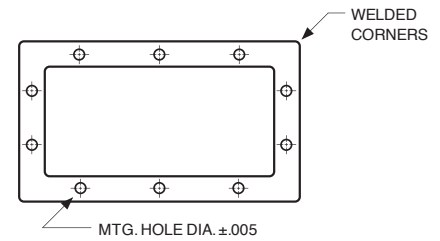

Trimshield Styles

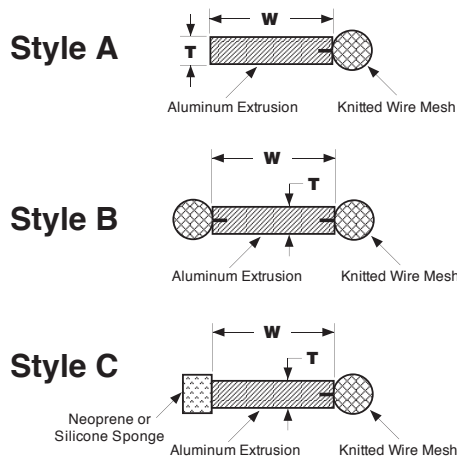

T	W	Style A	Style B	Style C
.093	.375	9X11	N/A	9X31
.093	.437	9X10	N/A	9X30
.125	.375	9X12	N/A	9X32
.125	.437	9X19	N/A	9X39
.125	.500	9X13	9021	9X33
.125	.625	9X14	9022	9X34
.125	.750	9X15	9023	9X35
.125	.875	9X18	N/A	9X38
.188	.500	N/A	9024	N/A

Tolerances: Mesh +0.030 -0.000 in.

FOR SIZES NOT SHOWN, PLEASE ASK!

How To Order

9000 Series - Trimshield

Example: Part Number 9111-2040-XXXX is Trimshield with monel mesh over silicone sponge - finished ends on Style A extrusion. **The sequential number is assigned by the factory.**

9	X	X	S	-	Y	Y	Z	Z	-	X	X	X	X
											SEQUENTIAL (XXXX)		
											ELASTOMER (ZZ)		
											00 None		
											10 Neoprene Sponge		
											30 Neoprene Hollow		
											40 Silicone Sponge		
											60 Silicone Hollow		
											WIRE (YY)		
											10 TCS		
											20 Monel		
											30 Aluminum		
											40 Stainless Steel		
											50 Other		
											SIZES (S)		
											See Chart For Size		
											STYLE (X)		
											1 Style A		
											2 Style B		
											3 Style C		
											4 Custom		
											CONFIGURATION (9X)		
											90 Strip-Bulk Lengths		
											91 Strip-Finished Ends To Specified Dimension		
											92 Strip-Fabricated Frame		

Vent & Filter Specifications

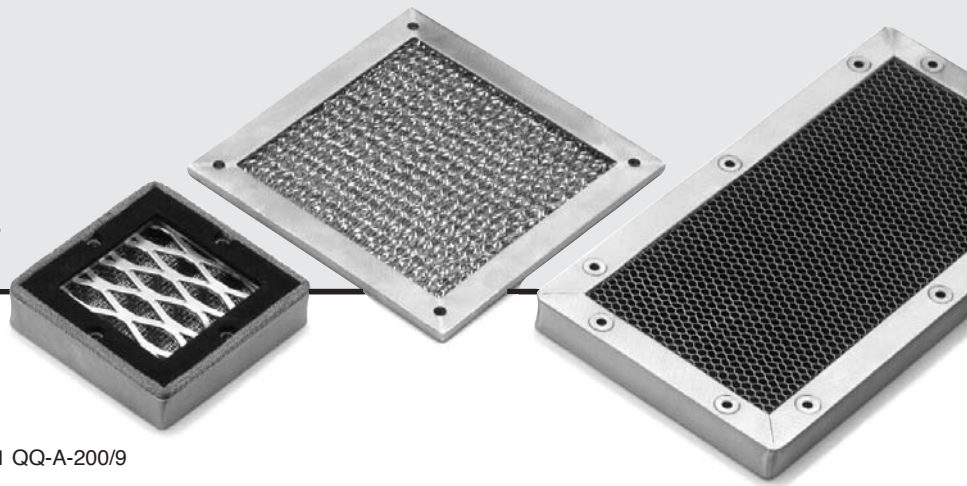

Material Specifications

Extrusion Aluminum Alloy 6063-T1 QQ-A-200/9
 Filter Media Aluminum Alloy 5056, per RR-W-365
 Honeycomb Aluminum Alloy MIL-C-7438
 Grilles Aluminum Alloy 3003-H-14, per QQ-A-359
 Finish Iridite to MIL-C-5541
 RFI Gasket Mesh (Monel, T.C.S., or Al), BeCu, or Metalized Fabric
 Twinseal Neoprene Sponge .093" Thk.
 to ASTM D6576, Type II, Grade A (Formerly MIL-R-6130)

8200 SERIES

EMI Shielding Performance 1/8 Cell Size, 1/4 Thick

Honeycomb Finish	E-Field 10MHz	Plane Wave 1GHz	Plane Wave 10GHz
Iridite	70 dB	50 dB	30 dB

8000 & 8300 SERIES

EMI Shielding Performance 1/8 Cell Size, 1/2 Thick

Standard Honeycomb Finish	H-Field 100kHz	E-Field 10MHz	Plane Wave	
	1GHz	10GHz	1GHz	10GHz
Iridite	40 dB	75 dB	60 dB	40 dB
Tin	70 dB	125 dB	100 dB	80 dB
Nickel	75 dB	130 dB	115 dB	95 dB
Cross-Cell Honeycomb Finish	H-Field 100kHz	E-Field 10MHz	Plane Wave	
	1GHz	10GHz	1GHz	10GHz
Iridite	60 dB	105 dB	90 dB	80 dB

Airflow Characteristics

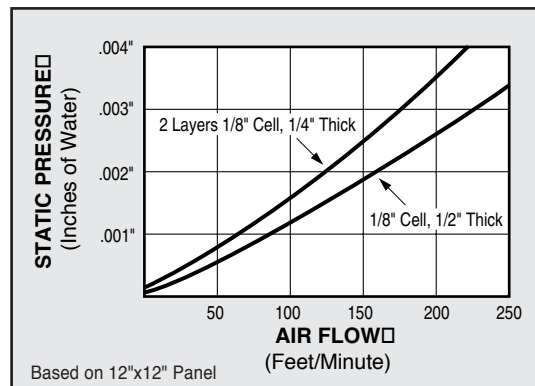

8500 SERIES

EMI Shielding Performance

Finish	H-Field 100kHz	E-Field 10MHz	Plane Wave	
	1GHz	10GHz	1GHz	10GHz
Iridite	50 dB	80 dB	55 dB	40 dB

Airflow Characteristics

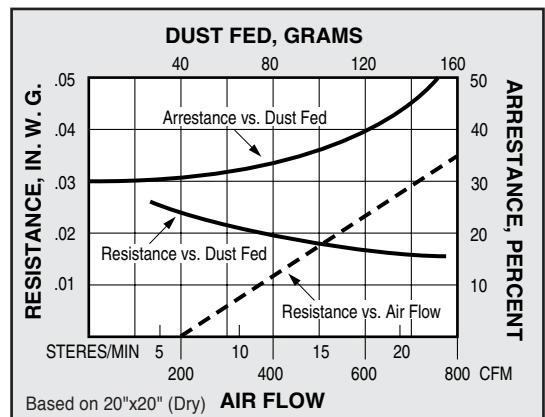

8900 SERIES

EMI Shielding Performance

Finish	H-Field 100kHz	E-Field 10MHz	Plane Wave	
	1GHz	10GHz	1GHz	10GHz
Iridite	45 dB	85 dB	55 dB	40 dB

Airflow Characteristics

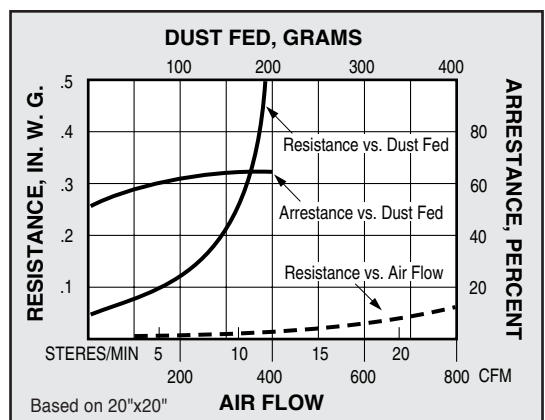

8000 Series Honeycomb Vents

The 8000 Series Vents are manufactured in both custom and standard configurations. Shielding performance is achieved from 1/8 cell aluminum honeycomb panels mounted in high strength extruded aluminum frames available in 8 styles as shown. Frame to enclosure shielding options include Twinseal (page 36), Mesh gaskets (page 32), Beryllium copper shielding strips (page 3) or Metalized Fabric Gaskets (page 30).

Shielding effectiveness and environmental protection can be improved by plating with tin or nickel. The highest level of shielding is achieved with a cross cell configuration where two 1/4 thick honeycomb panels are assembled with the foil seams oriented 90 degrees from each other.

Standard vents are available in Style 1 frame style, frame to enclosure shielding, finish and dimensional specifications are required. See Fig. 1.

for sizes. For custom requirements, frame style, frame to enclosure shielding, finish and dimensional specifications are required. See Fig. 1.

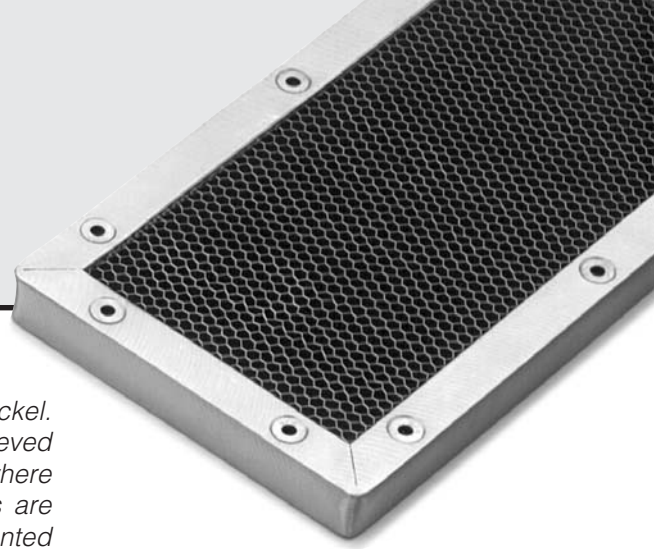

Honeycomb Vent Aluminum Frame Styles

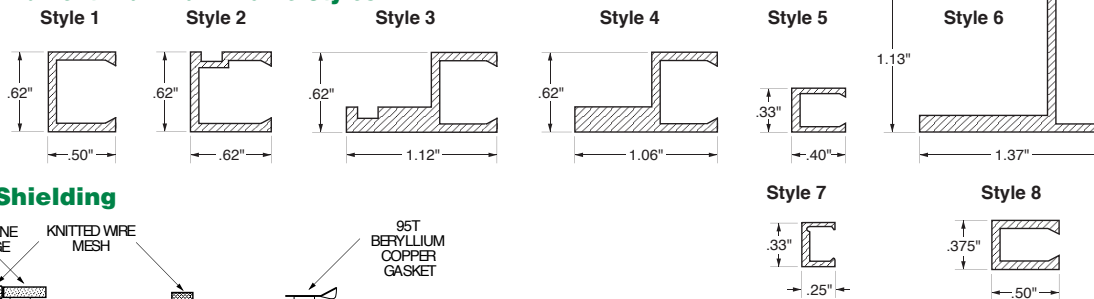

Frame Shielding

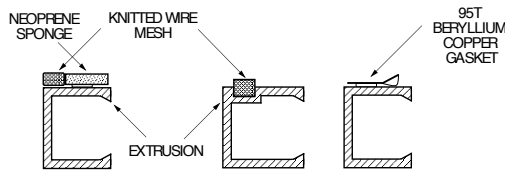
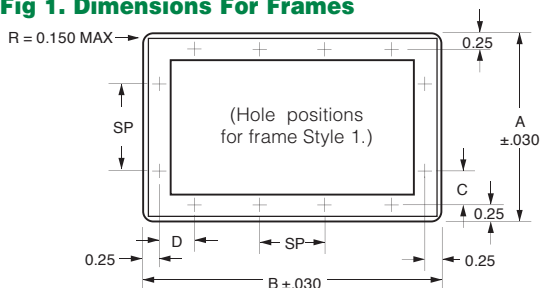

Fig 1. Dimensions For Frames



Supply dimensions A, B, C, & D for non-standard frames. Note: Try to avoid placing holes or fasteners at the corners of frame.

Standard Frame Sizes: Style 1

Outer Dimensions A x B	Sequential Part Number	Fasteners Vertical		Fasteners Horizontal	
		No.	C SP	No.	D SP
4" x 4"	0001	1	1.75" -	1	1.75" -
4" x 8"	0002	1	1.75" -	3	0.75" 3.00
5" x 5"	0003	1	2.25" -	2	0.75" 3.00
5" x 10"	0004	1	2.25" -	3	1.25" 3.50
6" x 6"	0005	2	1.00" 3.50	2	1.00" 3.50
6" x 12"	0006	2	1.00" 3.50	4	1.25" 3.00
7" x 7"	0007	2	1.50" 3.50	2	1.50" 3.50
7" x 14"	0008	2	1.50" 3.50	4	1.50" 3.50
8" x 8"	0009	2	2.00" 3.50	3	0.75" 3.00
8" x 16"	0010	3	0.75" 3.00	5	1.25" 3.25
10" x 10"	0011	3	1.25" 3.50	3	1.25" 3.50
12" x 12"	0012	4	1.25" 3.00	4	1.25" 3.00

FOR SIZES NOT SHOWN, PLEASE ASK!

How To Order

8000 Series Shielded Vent Panels - Honeycomb

Example: Part number 8001-3202-0009 is a shielded aluminum slant honeycomb vent with a Style 1 frame 8" x 8" and Twinseal with monel mesh gasket. **Unless standard, the sequential number is assigned by the factory.**

8 0 X X - Y Y Z Z - X X X X

8000 SERIES

SEQUENTIAL (XXXX)

SHIELD MEDIUM (Z)

- 1 Honeycomb straight
- 2 Honeycomb slant
- 3 Honeycomb cross-cell
- 4 Honeycomb cross-cell slant

HONEYCOMB MATERIAL (Z)

0 Aluminum 1/8 Cell

GASKET (YY)

- 00 None
- 10 Mesh (T.C.S.)
- 20 Mesh (Monel)
- 31 Twinseal With T.C.S. Mesh
- 32 Twinseal With Monel Mesh
- 33 Twinseal With Aluminum Mesh
- 40 Mesh (Aluminum)
- 50 BeCu 95T
- 60 Metalized Fabric
- 90 Over Foam Custom

FRAME (XX)

- 00 Custom
- 01 Style 1
- 02 Style 2
- 03 Style 3
- 04 Style 4
- 05 Style 5
- 06 Style 6
- 31 Style 7
- 32 Style 8

8200 Series Shielded Fan Vents

The 8200 Series Shielded Fan Vents with optional dust screens are designed to provide EMI shielding and maximum air flow without degrading the fan output. These vents provide a low cost option to perforated metal when airflow rates are critical. Tech-Etch stocks fan vents in 5 sizes corresponding to industry standard fans with standard 4-hole mounting. Shielding performance is achieved from 1/8 cell aluminum honeycomb panels mounted in high strength extruded aluminum frames with beryllium copper shielding strips for shielding the frame to the enclosure. Dust screens consisting of multilayer expanded aluminum can be added, but airflow will be restricted. See page 47 for EMI performance and complete specifications.

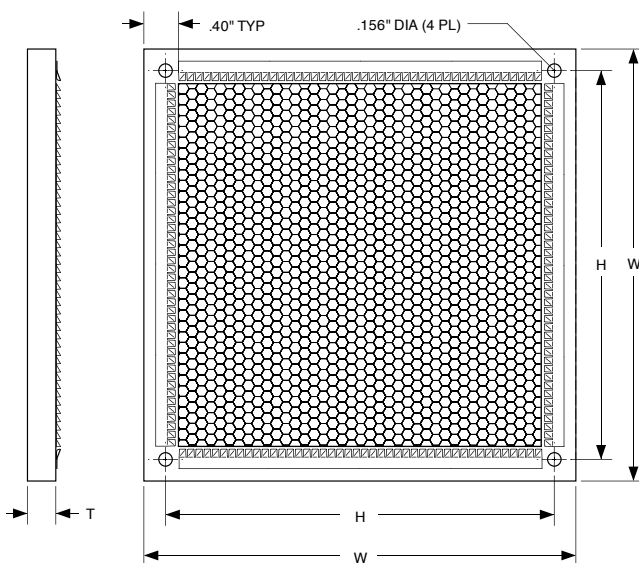
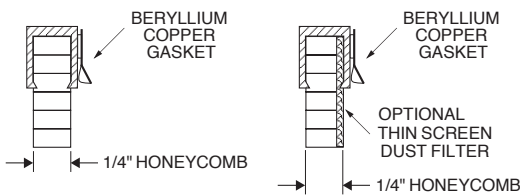
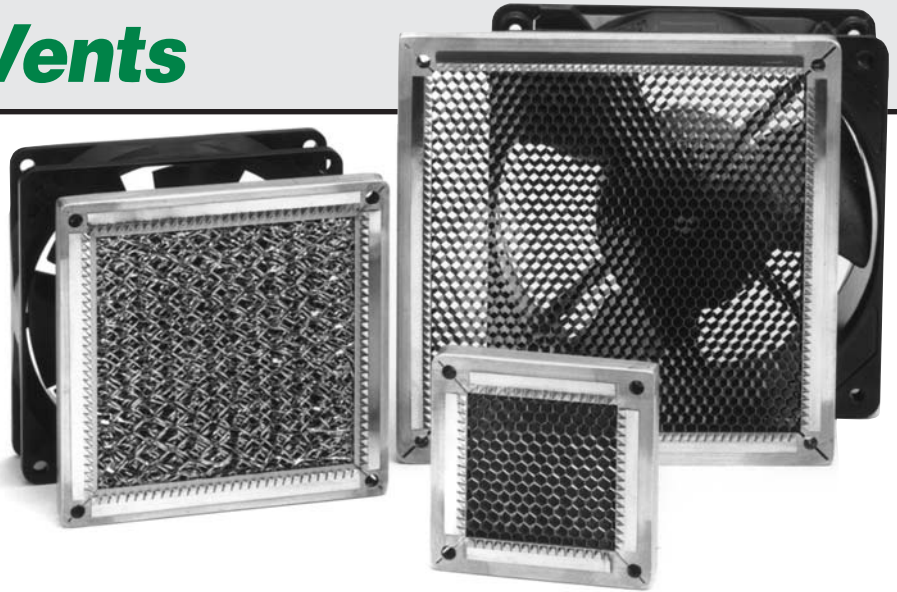

Sequential Number For Frame Size				
Size	Dimensions			Size Code XXXX
	W	H	T	
1	2.36"	1.97"	.33"	0197
2	3.14"	2.81"	.33"	0281
3	4.69"	4.13"	.33"	0413
4	5.00"	4.45"	.33"	0445
5	3.62"	3.25"	.33"	0325

How To Order

8200 Series Shielded Fan Vents - Honeycomb

Example: Part number 8205-5005-0445 is a shielded 1/8 cell honeycomb fan vent 5.00" wide by 5.00" high by .33" thick with an aluminum dust screen. **The sequential number determines the size of the frame.**

8 2 0 5 - 5 0 0 5 - 0 4 4 5

**8200
SERIES**

SEQUENTIAL

- 0197 Frame Size 1
- 0281 Frame Size 2
- 0413 Frame Size 3
- 0445 Frame Size 4
- 0325 Frame Size 5

DUST SCREEN (Z)

- 1 No dust screen
- 5 With dust screen

HONEYCOMB MATERIAL (Z)

- 0 Aluminum 1/8 Cell

GASKET (50)

- 50 BeCu 95T

FRAME (05)

- 05 Style 5

8300 Series Quiet Vents

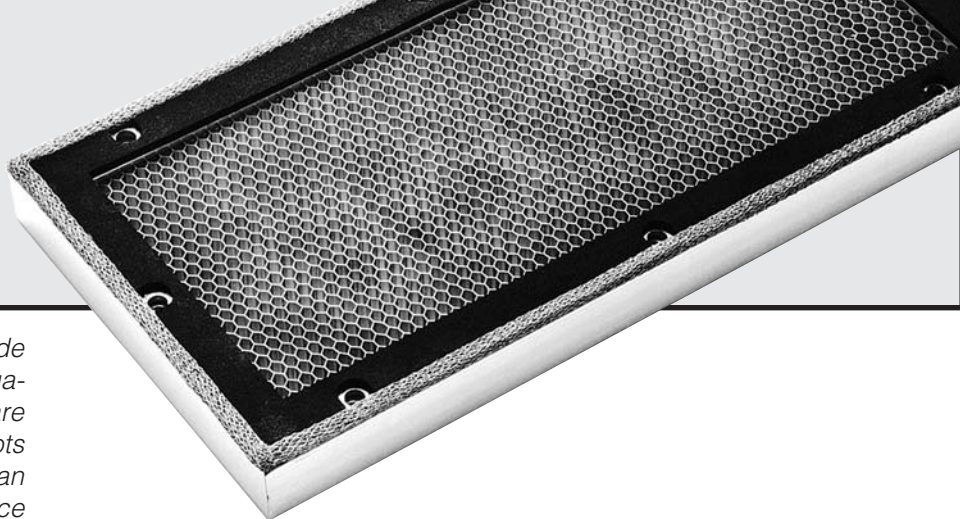

The 8300 Series Quiet Vents are designed to provide high shielding performance of up to 90 dB attenuation with very low costs. These honeycomb vents are offered as an alternative to perforated metal or slots to reduce turbulence and noise by providing an unrestricted and quiet airflow. Shielding performance is achieved from two 1/4 inch thick honeycomb panels assembled in a cross cell configuration. The panels are mounted in high strength extruded aluminum frames with optional captive fasteners or thru holes as detailed below. Frame to enclosure shielding comes from Twinseal (page 36).

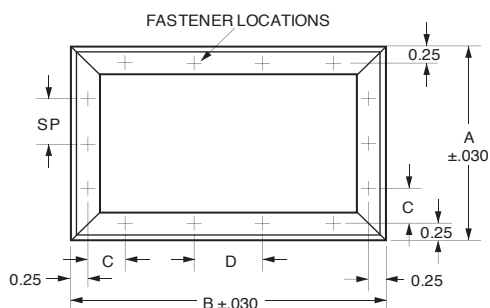

Sequential Numbers For Standard Frame Sizes

Vertical Size (A) of Frame	Horizontal Size (B) of Frame										
	3"	4"	5"	6"	7"	8"	9"	10"	12"	14"	16"
3"	0303	0304	0305	0306	0307	0308	0309	0310	0312	0314	0316
4"	0403	0404	0405	0406	0407	0408	0409	0410	0412	0414	0416
5"	0503	0504	0505	0506	0507	0508	0509	0510	0512	0514	0516
6"	0603	0604	0605	0606	0607	0608	0609	0610	0612	0614	0616
7"	0703	0704	0705	0706	0707	0708	0709	0710	0712	0714	0716
8"	0803	0804	0805	0806	0807	0808	0809	0810	0812	0814	0816
9"	0903	0904	0905	0906	0907	0908	0909	0910	0912	0914	0916
10"	1003	1004	1005	1006	1007	1008	1009	1010	1012	1014	1016
12"	1203	1204	1205	1206	1207	1208	1209	1210	1212	1214	1216
14"	1403	1404	1405	1406	1407	1408	1409	1410	1412	1414	1416
16"	1603	1604	1605	1606	1607	1608	1609	1610	1612	1614	1616

Fastener/Hole Locations

For the height (A) and the width (B) use the chart to determine number and location of the captive fasteners or through holes per side.

Standard Length	Number Of Fasteners	C	D
3" (A or B)	1	1.25"	NA
4" (A or B)	1	1.75"	NA
5" (A Only)	1	2.25"	NA
5" (B Only)	2	.75"	3.00"
6" (A or B)	2	1.00"	3.50"
7" (A or B)	2	1.50"	3.50"
8" (A Only)	2	2.00"	3.50"
8" (B Only)	3	.75"	3.00"
9" (A or B)	3	.75"	3.50"
10" (A or B)	3	1.25"	3.50"
12" (A or B)	4	1.25"	3.00"
14" (A or B)	4	1.50"	3.50"
16" (A or B)	5	1.25"	3.25"

Frame Style 1a and 1b

Style 1a has captive fasteners.
Style 1b has through holes.
Frame finish is MIL-C-5541 Iridite.
Other finishes can be supplied if required.

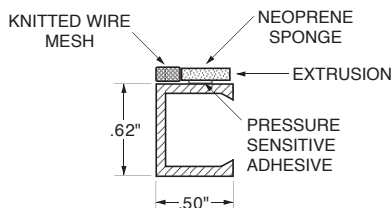

Example:
8301-3200-0506

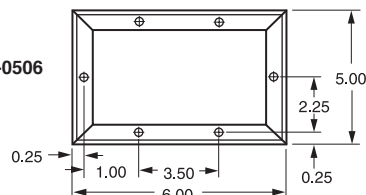

How To Order

8300 Series High Airflow Shielded Vents - Honeycomb

Example: Part number 8301-3200-0506 is an aluminum honeycomb 5" x 6" vent in a Style 1a frame with captive fasteners shielded with Twinseal. The sequential number specifies the height (A) and width (B) of the frame.

8 3 0 X - Z Z 0 0 - A A B B

8300 SERIES

SEQUENTIAL (AABB)

AA Vertical Height

BB Horizontal Width

HONEYCOMB MATERIAL (00)

00 Aluminum 1/8 Cell

GASKET (ZZ)

00 No Gasket

31 Twinseal Neoprene Elastomer and T.C.S. Mesh

32 Twinseal Neoprene Elastomer and Monel Mesh

33 Twinseal Neoprene Elastomer and Aluminum Mesh

FRAME (0X)

01 Style 1a (Captive Fasteners 8-32)

02 Style 1b (Through Holes .204 DIA)

8500 & 8900 Series Shielded Air Filters

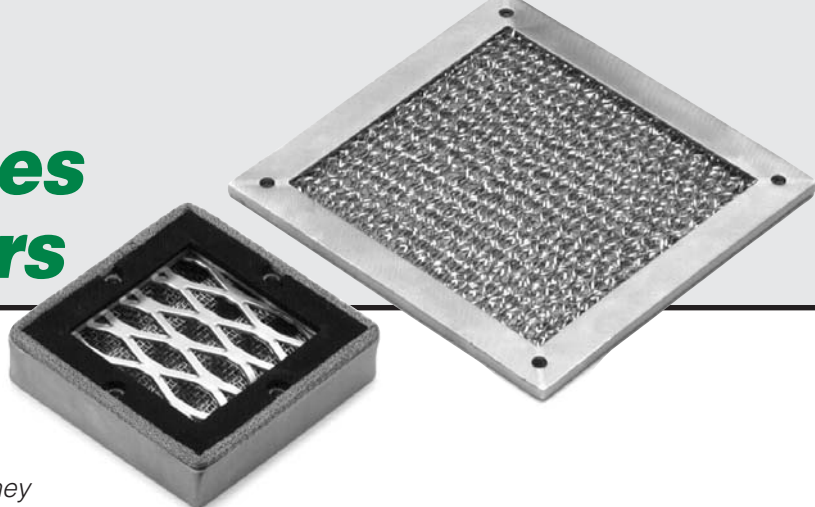

ALUMINUM MESH SHIELDED AIR FILTERS

Shielded filter and dust shields perform three functions: they attenuate EMI, they provide for a passage of cooling air, and they filter dust from the air flow. Designed for use in industrial environments at low to medium air flow rates, they can be cleaned either by immersion and agitation in a suitable solvent or by air blasting. The filter is comprised of three layers of corrugated aluminum mesh aligned to provide maximum dust trapping effectiveness and minimum resistance to airflow. The filter material is contained in a rigid "C" channel aluminum frame of all welded construction and protected on each side with an expanded metal grid.

Electronic filters and dust shields are manufactured to meet the needs of individual applications. For custom requirements, please supply a detailed drawing with the following information:

- Location and size or type of fixing holes or fasteners (6/32 or 8/32 UNC, preferred). Use table and Fig. 1 on page 48 as a guide for hole/insert spacings.
- Outer dimensions of filter.
- Type of gasket required.

How To Order

**8500 Series
Shielded Air Filters - Aluminum Mesh**

Example: Part number 8502-1060-0250 is a shielded air filter with Style 2 frame, T.C.S. wire mesh and 3-layer aluminum screen. **Unless standard, the sequential number is assigned by the factory.**

8 5 X X - Y Y 6 0 - X X X X					
8500 SERIES				SEQUENTIAL (XXXX)	
				FILTER MEDIUM (60) 60 Aluminum 3-Layer Screen	
				GASKET (YY)	
				00 None 10 Mesh (T.C.S.) 20 Mesh (Monel) 31 Twinseal With T.C.S. Mesh 32 Twinseal With Monel Mesh 33 Twinseal With Aluminum Mesh 40 Mesh (Aluminum) 90 Custom	
				FRAME (XX)	
				00 Custom 02 Style 2 04 Style 4 01 Style 1 03 Style 3	

THIN SCREEN SHIELDED AIR FILTERS

Composed of expanded multi-layer aluminum, Thin Screen Shields combine the functions of EMI shielding with efficient dust filtering and ventilation. Thinner than electronic filter dust shields, they provide better dust extraction, but with greater restriction of air flow. They cost less than electronic dust shields and honeycomb.

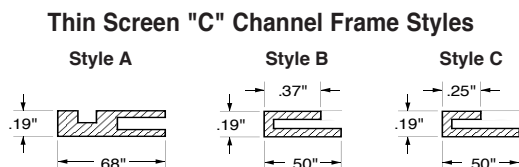

Special Notes

Avoid locating holes or fasteners in corners of frame.

When ordering please furnish a detailed drawing specifying all dimensions shown in Fig. 1 on page 48, including size and location of mounting holes, and type of gasket required.

How To Order

**8900 Series
Shielded Air Filters - Thin Screen Shields**

Example: Part number 8920-2070-0100 is Thin Shield Screen with Style A frame and mesh gasketing. **Sequential number is assigned by the factory. Note: When ordering, furnish a detailed drawing specifying size, hole locations and frame design.**

8 9 X X - Y Y 7 0 - X X X X					
8900 SERIES				SEQUENTIAL (XXXX)	
				FILTER MEDIUM (70) 70 Thin Screen	
				GASKET (YY)	
				00 None 20 Mesh (Monel)	
				FRAME (XX)	
				20 Style A 30 Style B 40 Style C	

Photoetched Custom-Designed Shielding

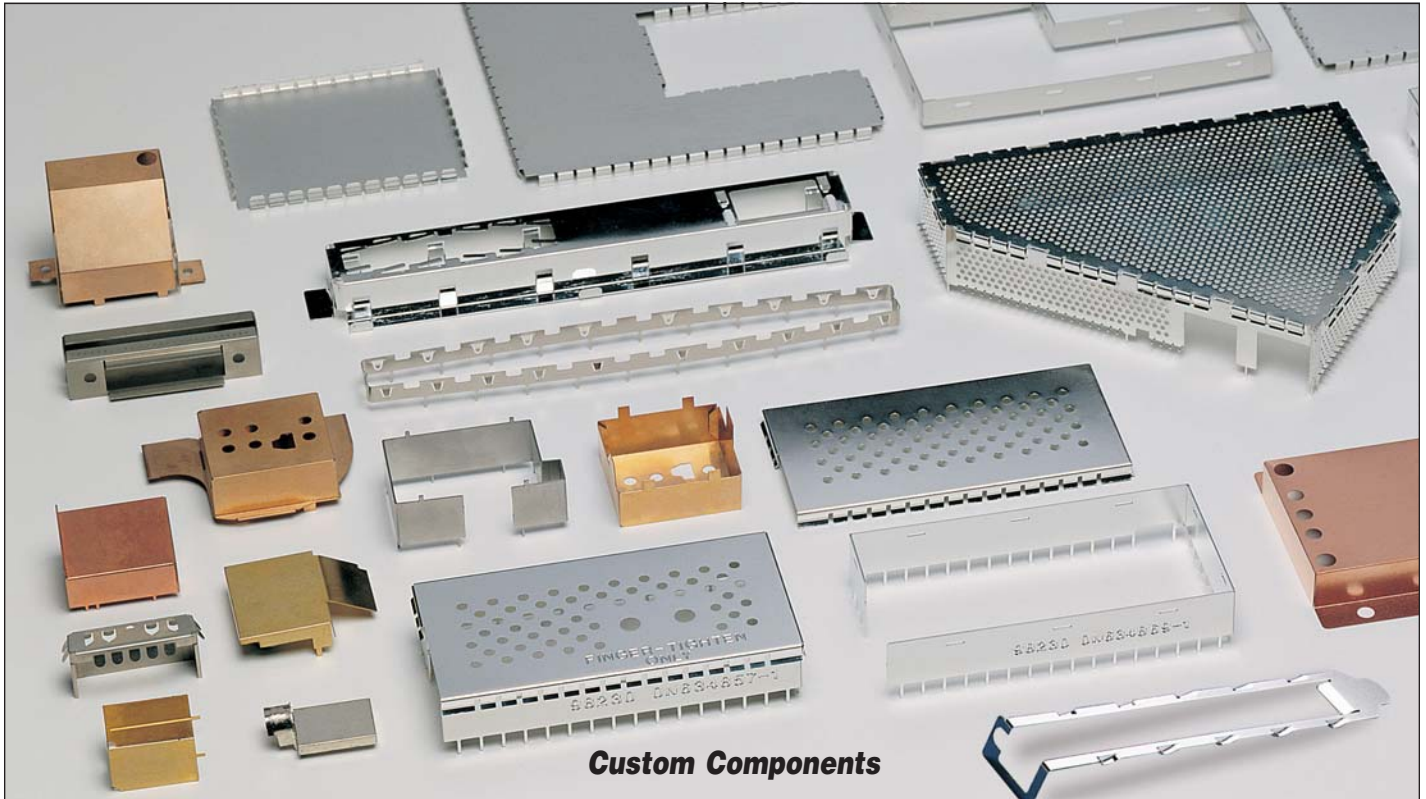

Custom Components

To avoid expensive form tooling, Tech-Etch uses photoetch fabrication to custom design beryllium copper and stainless steel shielding components in small quantities and also for prototypes before high-

volume requirements where progressive dies may be utilized. Custom expansion slot connector gaskets and board level shielding components are produced both quickly and economically.

BeCu Shielding in Rolls or Strips



All of the finger stock strips are available cut to any length and certain items are available in rolls up to 25 feet long.

Visit our web site for up-to-date information on shielding products, precision parts manufacturing and flexible circuits.

www.tech-etch.com

Other EMI Shielding Products

- **Shielded Windows**
Provide optical transmission and EMI shielding for enclosures requiring visual access to displays.
- **Shieldwrap**
Knitted mesh used to shield cable and to dissipate corona discharge at high-voltage splices.
- **Contact Rings**
Contact rings can be fabricated in many variations from finger stock shielding.

Call for *Data Sheets* on these products!

Call for Precision Parts and Flexible Circuits Capabilities Brochures



Tech-Etch

The Leader in Shielding Innovation

TECH-ETCH, INC., 45 Aldrin Road, Plymouth, MA 02360 USA • TEL 508-747-0300 • FAX 508-746-9639

ISO 9001:2000
REGISTERED

LITHO IN U.S.A.
057