

# IBM z14 Technical Introduction

Bill White

Hervey Kamga

Michal Kordyzon

Octavian Lascu

Frank Packheiser

John Troy

Esra Ufacik

Bo Xu



**IBM Z**





International Technical Support Organization

**IBM z14 Technical Introduction**

October 2018

**Note:** Before using this information and the product it supports, read the information in “Notices” on page vii.

**Second Edition (October 2018)**

This edition applies to the following IBM Z platform: IBM z14™.

**© Copyright International Business Machines Corporation 2018. All rights reserved.**

Note to U.S. Government Users Restricted Rights -- Use, duplication or disclosure restricted by GSA ADP Schedule Contract with IBM Corp.

# Contents

<b>Notices</b> .....	vii
Trademarks .....	viii
<b>Preface</b> .....	ix
Authors .....	ix
Now you can become a published author, too .....	x
Comments welcome .....	xi
Stay connected to IBM Redbooks .....	xi
<b>Chapter 1. The base of a trust economy</b> .....	1
1.1 The z14: A secure platform integrated and open by design .....	2
1.1.1 Securing data with pervasive encryption .....	3
1.1.2 Transforming a transactional platform into a data powerhouse .....	3
1.1.3 Getting more out of the platform with IT Operational Analytics .....	4
1.1.4 Providing resilience with key to zero downtime .....	4
1.1.5 Accelerating digital transformation with agile service delivery .....	5
1.1.6 Revolutionizing business processes .....	6
1.1.7 Blending open source and Z technologies .....	6
1.2 z14 technical description .....	7
1.2.1 Technical highlights .....	7
1.2.2 Storage connectivity .....	9
1.2.3 Network connectivity .....	10
1.2.4 Cryptography .....	11
1.2.5 Clustering connectivity .....	12
1.2.6 Special-purpose features and functions .....	12
1.2.7 Capacity on demand and performance .....	13
1.2.8 Reliability, availability, and serviceability .....	14
1.3 Software support .....	14
1.3.1 IBM compilers .....	15
<b>Chapter 2. IBM z14 hardware overview</b> .....	17
2.1 Models and upgrade paths .....	18
2.2 Frames and cabling .....	19
2.3 CPC drawers .....	21
2.3.1 Single chip modules .....	22
2.3.2 Processor unit .....	23
2.3.3 Memory .....	25
2.3.4 Hardware system area .....	26
2.4 I/O system structure .....	27
2.5 Power and cooling .....	29
2.5.1 Radiator (air) cooling option .....	29
2.5.2 Water cooling option .....	30
2.5.3 High Voltage Direct Current power feature .....	30
2.5.4 Power considerations .....	30
<b>Chapter 3. Supported features and functions</b> .....	31
3.1 I/O features at a glance .....	32
3.2 Native PCIe features and integrated firmware processor .....	35
3.3 Storage connectivity .....	36

3.3.1	zHyperLink Express	36
3.3.2	FICON functions	36
3.3.3	FCP functions	38
3.3.4	FICON Express16S+	39
3.3.5	FICON Express16S (carry forward only)	39
3.3.6	FICON Express8S (carry forward only)	40
3.4	Network connectivity	40
3.4.1	OSA-Express functions	40
3.4.2	OSA-Express7S	42
3.4.3	OSA-Express6S	42
3.4.4	OSA-Express5S (carry forward only)	43
3.4.5	OSA-Express4S (carry forward only)	44
3.4.6	HiperSockets functions	44
3.4.7	Shared Memory Communications functions	46
3.4.8	RoCE Express features	47
3.5	Compression options	48
3.5.1	Compression Coprocessor	48
3.5.2	zEnterprise Data Compression	48
3.6	Cryptographic features	48
3.6.1	CP Assist for Cryptographic Function	48
3.6.2	Crypto Express6S	49
3.6.3	Crypto Express5S (carry forward only)	50
3.6.4	Web deliverables	50
3.7	Coupling and clustering	50
3.7.1	Coupling Express Long Reach	51
3.7.2	Integrated Coupling Adapter: Short Reach	51
3.7.3	Host Channel Adapter3: Optical Long Reach	51
3.7.4	Host Channel Adapter3: Optical	51
3.7.5	Internal coupling	52
3.7.6	Coupling Facility Control Code Level	52
3.8	Virtual Flash Memory	52
3.9	Server Time Protocol	53
3.10	Hardware Management Console and Support Element	54
	<b>Chapter 4. Strengths of the z14 platform</b>	<b>57</b>
4.1	Technology improvements	58
4.1.1	Processor design highlights	58
4.1.2	Memory	60
4.2	Virtualization	62
4.2.1	Hardware virtualization	65
4.2.2	IBM Z based clouds	68
4.2.3	Secure Service Container	70
4.3	Capacity and performance	71
4.3.1	Capacity settings	71
4.3.2	Capacity on demand	72
4.3.3	z14 performance	74
4.4	Reliability, availability, and serviceability	76
4.4.1	RAS capability for the Support Element	78
4.4.2	RAS capability for the Hardware Management Console	78
4.5	High availability with Parallel Sysplex	78
4.6	Pervasive encryption	82
	<b>Chapter 5. Operating system support</b>	<b>85</b>

5.1 Software support summary . . . . .	86
5.1.1 Operating systems summary . . . . .	86
5.1.2 Application development and languages . . . . .	88
5.1.3 IBM compilers . . . . .	89
5.2 Support by operating system . . . . .	89
5.2.1 z/OS . . . . .	90
5.2.2 z/VM . . . . .	90
5.2.3 z/VSE . . . . .	91
5.2.4 z/TPF . . . . .	91
5.2.5 Linux on IBM Z . . . . .	91
5.2.6 KVM hypervisor . . . . .	92
5.3 Software licensing . . . . .	92
5.4 References . . . . .	93





# Notices

This information was developed for products and services offered in the US. This material might be available from IBM in other languages. However, you may be required to own a copy of the product or product version in that language in order to access it.

IBM may not offer the products, services, or features discussed in this document in other countries. Consult your local IBM representative for information on the products and services currently available in your area. Any reference to an IBM product, program, or service is not intended to state or imply that only that IBM product, program, or service may be used. Any functionally equivalent product, program, or service that does not infringe any IBM intellectual property right may be used instead. However, it is the user's responsibility to evaluate and verify the operation of any non-IBM product, program, or service.

IBM may have patents or pending patent applications covering subject matter described in this document. The furnishing of this document does not grant you any license to these patents. You can send license inquiries, in writing, to:

*IBM Director of Licensing, IBM Corporation, North Castle Drive, MD-NC119, Armonk, NY 10504-1785, US*

INTERNATIONAL BUSINESS MACHINES CORPORATION PROVIDES THIS PUBLICATION "AS IS" WITHOUT WARRANTY OF ANY KIND, EITHER EXPRESS OR IMPLIED, INCLUDING, BUT NOT LIMITED TO, THE IMPLIED WARRANTIES OF NON-INFRINGEMENT, MERCHANTABILITY OR FITNESS FOR A PARTICULAR PURPOSE. Some jurisdictions do not allow disclaimer of express or implied warranties in certain transactions, therefore, this statement may not apply to you.

This information could include technical inaccuracies or typographical errors. Changes are periodically made to the information herein; these changes will be incorporated in new editions of the publication. IBM may make improvements and/or changes in the product(s) and/or the program(s) described in this publication at any time without notice.

Any references in this information to non-IBM websites are provided for convenience only and do not in any manner serve as an endorsement of those websites. The materials at those websites are not part of the materials for this IBM product and use of those websites is at your own risk.

IBM may use or distribute any of the information you provide in any way it believes appropriate without incurring any obligation to you.

The performance data and client examples cited are presented for illustrative purposes only. Actual performance results may vary depending on specific configurations and operating conditions.

Information concerning non-IBM products was obtained from the suppliers of those products, their published announcements or other publicly available sources. IBM has not tested those products and cannot confirm the accuracy of performance, compatibility or any other claims related to non-IBM products. Questions on the capabilities of non-IBM products should be addressed to the suppliers of those products.

Statements regarding IBM's future direction or intent are subject to change or withdrawal without notice, and represent goals and objectives only.

This information contains examples of data and reports used in daily business operations. To illustrate them as completely as possible, the examples include the names of individuals, companies, brands, and products. All of these names are fictitious and any similarity to actual people or business enterprises is entirely coincidental.

## COPYRIGHT LICENSE:

This information contains sample application programs in source language, which illustrate programming techniques on various operating platforms. You may copy, modify, and distribute these sample programs in any form without payment to IBM, for the purposes of developing, using, marketing or distributing application programs conforming to the application programming interface for the operating platform for which the sample programs are written. These examples have not been thoroughly tested under all conditions. IBM, therefore, cannot guarantee or imply reliability, serviceability, or function of these programs. The sample programs are provided "AS IS", without warranty of any kind. IBM shall not be liable for any damages arising out of your use of the sample programs.

# Trademarks

IBM, the IBM logo, and ibm.com are trademarks or registered trademarks of International Business Machines Corporation, registered in many jurisdictions worldwide. Other product and service names might be trademarks of IBM or other companies. A current list of IBM trademarks is available on the web at “Copyright and trademark information” at <http://www.ibm.com/legal/copytrade.shtml>

The following terms are trademarks or registered trademarks of International Business Machines Corporation, and might also be trademarks or registered trademarks in other countries.

Bluemix®	IBM z13®	RMF™
CICS®	IBM z13s®	System Storage®
Concert®	IBM z14™	System z®
Db2®	IMS™	System z10®
DB2®	Interconnect®	System z9®
DS8000®	Language Environment®	WebSphere®
ECKD™	Parallel Sysplex®	z/Architecture®
FICON®	Passport Advantage®	z/OS®
GDPS®	PR/SM™	z/VM®
Geographically Dispersed Parallel Sysplex™	Processor Resource/Systems Manager™	z/VSE®
HiperSockets™	Rational®	z10™
HyperSwap®	Rational Team Concert™	z13®
IBM®	Redbooks®	z13s®
IBM MobileFirst®	Redbooks (logo)  ®	z9®
IBM Z®	Resource Link®	zEnterprise®

The following terms are trademarks of other companies:

Linux is a trademark of Linus Torvalds in the United States, other countries, or both.

Java, and all Java-based trademarks and logos are trademarks or registered trademarks of Oracle and/or its affiliates.

Other company, product, or service names may be trademarks or service marks of others.

# Preface

This IBM® Redbooks® publication introduces the latest IBM z platform, the IBM z14™. It includes information about the Z environment and how it helps integrate data and transactions more securely, and can infuse insight for faster and more accurate business decisions.

The z14 is a state-of-the-art data and transaction system that delivers advanced capabilities, which are vital to the digital era and the trust economy. This system includes the following functionality:

- ▶ Securing data with pervasive encryption
- ▶ Transforming a transactional platform into a data powerhouse
- ▶ Getting more out of the platform with IT Operational Analytics
- ▶ Providing resilience with key to zero downtime
- ▶ Accelerating digital transformation with agile service delivery
- ▶ Revolutionizing business processes
- ▶ Blending open source and Z technologies

This book explains how this system uses both new innovations and traditional Z strengths to satisfy growing demand for cloud, analytics, and mobile applications. With the z14 as the base, applications can run in a trusted, reliable, and secure environment that both improves operations and lessens business risk.

## Authors

This book was produced by a team of specialists from around the world working at the International Technical Support Organization, Poughkeepsie Center.

**Bill White** is an IBM Redbooks Project Leader and Senior Networking and Connectivity Specialist at IBM Redbooks, Poughkeepsie Center.

**Hervey Kamga** is an IBM Z® Product Engineer with the EMEA I/O Connectivity Team in Montpellier, France. Prior to that, he was a Support Engineer and Engineer On Site for 13 years with Sun Microsystems and Oracle in EMEA. Hervey's areas of expertise include Oracle Solaris (operating system and hardware products), Virtualization (VMware and virtualBox), Linux (Ubuntu), and Z I/O features and protocols (IBM FICON® and OSA).

**Michal Kordyzo** is an IBM Z Client Technical Specialist at IBM Poland with 12 years of experience with the Z platform. He also has expertise in LinuxONE, mainframe architecture, Linux systems, Hyperledger fabric, Node.js, and Machine Learning algorithms.

**Octavian Lascu** is an IBM Redbooks Project Leader and a Senior IT Consultant for IBM Romania with over 20 years of experience. He specializes in designing, implementing, and supporting complex IT infrastructure environments (systems, storage, and networking), including high availability and disaster recovery solutions and high-performance computing deployments. He has developed materials for and taught over 50 workshops for technical audiences around the world. He has written several IBM publications.

**Frank Packheiser** is a Senior zIT Specialist at the Field Technical Sales Support office in Germany. He has 26 years of experience in IBM Z. Frank has worked for 10 years in the IBM Education Center in Germany, developing and providing professional training. He also provides professional services to Z and mainframe clients. In 2008 and 2009, Frank supported clients in Middle East/North Africa (MENA) as a zIT Architect. In addition to co-authoring several IBM Redbooks publications since 1999, he has been an official ITSO presenter at ITSO workshops for the last four years.

**John Troy** is an IBM Z and Storage hardware National Top Gun in the northeast area of the United States. He has 36 years of experience in the service field. His areas of expertise include technical and customer support for Z and high-end storage systems. John has been a Z hardware technical support course designer, developer, and instructor for the last seven generations of IBM high-end servers.

**Esra Ufacik** is an IBM Z Lead Architect in IBM Systems covering Asia Pacific. Throughout her career, she has held various roles in different companies with Z products, such as IBM z/OS® and IBM Parallel Sysplex®. These roles include implementation, migration, SAN, storage, software problem support, solution designing, Linux on Z, IT Optimization, TCO assessments, technical authoring, and guest lecturing. In March 2016, she was assigned as IOT lead for Blockchain in IBM Systems division.

**Bo Xu** is a Senior System Service Representative in China. He has more than 20 years of experience with Z products maintenance support. He has been working in the GTS department to provide Z support to clients as a local Top Gun, and provide second-level support for IBM DS8000® as one of his country's Top Gun & Skill Owners. His areas of expertise include Z hardware, channel connectivity, and IBM DS8000.

Thanks to the following people for their contributions to this project:

Todd Arnold  
Les Geer  
Michael Groetzner  
Parwez Hamid  
Gary King  
Jeff Kubala  
Barbara Sannerud  
Philip Sciuto  
Christine Smith  
Dave Surman  
Rhonda Sundlo  
Marna Walle  
Barara Weiler  
Harry Yudenfriend  
Monika Zimmermann

## Now you can become a published author, too

Here's an opportunity to spotlight your skills, grow your career, and become a published author, all at the same time. Join an ITSO residency project and help write a book in your area of expertise, while honing your experience using leading-edge technologies. Your efforts will help to increase product acceptance and customer satisfaction, as you expand your network of technical contacts and relationships. Residencies run two - six weeks in length, and you can participate either in person or as a remote resident working from your home base.

Find out more about the residency program, browse the residency index, and apply online:

[ibm.com/redbooks/residencies.html](http://ibm.com/redbooks/residencies.html)

## Comments welcome

Your comments are important to us.

We want our books to be as helpful as possible. Send us your comments about this book or other IBM Redbooks publications in one of the following ways:

- ▶ Use the online **Contact us** review Redbooks form:

[ibm.com/redbooks](http://ibm.com/redbooks)

- ▶ Send your comments in an email:

[redbooks@us.ibm.com](mailto:redbooks@us.ibm.com)

- ▶ Mail your comments:

IBM Corporation, International Technical Support Organization  
Dept. HYTD Mail Station P099  
2455 South Road  
Poughkeepsie, NY 12601-5400

## Stay connected to IBM Redbooks

- ▶ Find us on Facebook:

<http://www.facebook.com/IBMRedbooks>

- ▶ Follow us on Twitter:

<http://twitter.com/ibmredbooks>

- ▶ Look for us on LinkedIn:

<http://www.linkedin.com/groups?home=&gid=2130806>

- ▶ Explore new Redbooks publications, residencies, and workshops with the IBM Redbooks weekly newsletter:

<https://www.redbooks.ibm.com/Redbooks.nsf/subscribe?OpenForm>

- ▶ Stay current on recent Redbooks publications with RSS Feeds:

<http://www.redbooks.ibm.com/rss.html>





# The base of a trust economy

How your enterprise uses its unique data to differentiate from competitors defines your success. Deriving real-time insights and increasing value through data relevance is becoming the mechanism by which organizations maintain customer trust and gain competitive advantage.

Without question, *trust* is the most crucial component of successful business interactions. At the core of all business relationships, trust starts with reliable data and transactions. For that reason, they must be always protected, always available, always delivered with speed, and infused with value. (This is the basis of leadership for a trust economy.)

In addition, no business or organization can ignore the effects of today's digital transformation. Data and transaction volumes are growing exponentially, and workload complexity is rapidly expanding. There is broad demand for new services and individualized customer experiences. Across industries, newcomers are disrupting markets by using cloud technologies to develop and deploy applications with speed and agility. Established business models must adapt to compete with players who are not constrained by legacy and tradition.

The latest member of the IBM Z family, the z14 has a tried-and-true architecture to support your digital transformation, create a strong cloud infrastructure, and expose back-end services through secure APIs. The z14 can also streamline your ability to integrate disparate data center systems and create a single, cohesive IT shop.

The z14 can help your organization make consistently optimal decisions, gain operational data insights so you get the most value from your IT investment, and fully protect your data (in-flight and at-rest), while facilitating regulatory compliance.

Leadership for a trust economy can be built on the z14. It is the premier system for enabling data as the new security perimeter, and is designed for data serving in a cognitive era. The z14, more than any other platform, offers a high-value architecture that supports an open and connected world.

This chapter includes the following topics:

- ▶ 1.1, "The z14: A secure platform integrated and open by design" on page 2
- ▶ 1.2, "z14 technical description" on page 7
- ▶ 1.3, "Software support" on page 14

# 1.1 The z14: A secure platform integrated and open by design

The z14 introduces a paradigm shift for protecting data and transactions, from selective encryption to pervasive encryption.<sup>1</sup> It includes higher-performance processors and co-processors, increased cache density, up to 32 TB of memory, enhanced access to data, improved virtualization for running Linux on z Systems, and enhancements for Java and other compilers.

The z14 offers a fast, scalable, and securable enterprise system. Compared to its predecessor platforms, the z14 provides more of what you need to satisfy today’s growing IT demands:

- ▶ Compute power for increased throughput
- ▶ Large-scale memory to process data faster
- ▶ Industry-unique cache design to optimize performance
- ▶ Accelerated I/O bandwidth to process massive amounts of data
- ▶ Data compression to economically store and process information
- ▶ High-speed cryptographic operations to help secure transactions and data

From the hundreds of microprocessors to the software stack, the z14 is built to quickly respond to change. This evolution of the Z platform embodies a proven infrastructure designed from the ground up for data and transactions. Figure 1-1 shows the z14.



Figure 1-1 The IBM z14

The new Z platform incorporates the ability to access larger data in memory, and has industry-exclusive I/O processors for offloading data-intensive workloads.

<sup>1</sup> Pervasive encryption is a data-centric approach to information security that entails protecting data that is entering and exiting the z14 platform through widespread encryption. For more information, see “Pervasive encryption” on page 82.



The z14 meets the needs of the trust economy and digital era using these techniques:

- ▶ Securing data with pervasive encryption
- ▶ Transforming a transactional platform into a data powerhouse
- ▶ Getting more out of the platform with IT Operational Analytics
- ▶ Providing resilience with key to zero downtime
- ▶ Accelerating digital transformation with agile service delivery
- ▶ Revolutionizing business processes
- ▶ Blending open source and Z technologies

### 1.1.1 Securing data with pervasive encryption

The z14 excels with security features that are built into the hardware, firmware, and operating systems. The built-in features range from storage protection keys and workload isolation to granular audit capabilities, and more. The Central Processor Assist for Cryptographic Function (CPACF), standard on every core, supports pervasive encryption and provides hardware acceleration for encryption operations. In addition, the new Crypto Express6S gets a performance boost on z14. Combined, these two enhancements perform encryption more efficiently on the z14 than on earlier Z platforms.

IBM Z pervasive encryption provides the comprehensive data protection that your organization and customers demand. By placing the security controls on the data itself, the solution creates an envelope of protection around the data on Z. For example, Z pervasive encryption helps protect the at-rest and in-flight data that is on your Z infrastructure. Also, centralized, policy-based data encryption controls significantly reduce the costs that are associated with data security and regulatory compliance, including the new General Data Protection Regulations (GDPR).<sup>2</sup>

IBM Z pervasive encryption implements this comprehensive security with your ongoing operations in mind. Therefore, it does not require you to make any application changes, and can be implemented by using policy-based controls with low overhead. These capabilities can slash the costs associated with data security and compliance.

### 1.1.2 Transforming a transactional platform into a data powerhouse

Currently, data is one of the most valuable resources an organization possesses. Deriving insights from that data to drive optimal business decisions becomes one of the biggest challenges. To maximize the value of that resource, your enterprise might need to integrate additional external data sources to extract hidden insights.

For decades, clients typically copied business-critical data from their mainframe transactional systems to other platforms, or even data lakes, to perform sophisticated analytics. This process was inefficient, expensive, time-consuming, and introduced both risk on lower-security platforms and data latency.

By accessing your enterprise data in-place with minimal data duplication or movement, you can minimize the cost and complexity of analytics. You can also make enterprise data highly accessible to analytics applications and tools by integrating transactional and analytics processing, and protect sensitive data by keeping it within the secure Z platform.

---

<sup>2</sup> For more information about GDPR, see the [Clear the Path to the GDPR](#) website.

Because of the advanced infrastructure, with double the cache density on each chip and up to 32 TB memory, the z14 can support state-of-the-art cognitive solutions:

- ▶ Apache Spark: An open source, in-place analytics solution for z/OS that simplifies big data analysis. Apache Spark gives developers and data scientists the ability to analyze business-critical z/OS data in place, with no data movement. Apache Spark on z/OS can also provide a federated view by accessing and analyzing distributed and local data.
- ▶ IBM Machine Learning for z/OS: A comprehensive solution that manages the entire machine learning workflow, beginning with quick ingestion and transformation of Z data where it resides. The solution then securely creates, deploys, and manages high quality self-learning behavior models to help you extract hidden insights that more accurately anticipate organizational needs.
- ▶ The IBM DB2® Analytics Accelerator for z/OS: A high-performance appliance that transforms your mainframe into a highly efficient transactional and analytics-processing environment. It supports the full lifecycle of a real-time analytics solution on a single system that integrates transactional data, historical data, and predictive analytics.

### 1.1.3 Getting more out of the platform with IT Operational Analytics

Today, demands for 24 x 7 high-performance operations continue to rise. At the same time, allowed service windows shrink and are much less frequent. Increasing system complexity makes planning, maintaining, and troubleshooting more difficult and time consuming. IT operations analytics represent a possible solution to this challenge.

The z14 provides the infrastructure to host real-time analytics tools so you can clearly see your operating environment, then maximize operational efficiencies to help reduce costs.

IBM designed IBM Operations Analytics for z (IOAz), IBM Common Data Provider for z, and IBM z Operational Insights to ensure that your Z operates at peak performance. To get the most out of your system, Operations Analytics for z provides deep insights based on IBM's industry-leading expertise into your Z operational data.

**Note:** IBM z Advanced Workload Analysis Reporter (IBM zAware), which used to be delivered as a firmware appliance running on a dedicated LPAR, is now part of IOAz.

### 1.1.4 Providing resilience with key to zero downtime

Every second of downtime (planned or unplanned) can mean lost revenue. It is crucial to keep critical systems running 24 x 7, and to rapidly recover from an outage and resume critical business operations.

The Z in IBM Z stands for zero downtime, and the z14 has the same proven reliability that all IBM Z platforms are known for. Like previous generations, the z14 provides technology and services to help identify and remove single points of failures (SPOFs) in critical components. Also, with platform-level redundancy, the z14 is designed to handle failures while maintaining user access. Components can be repaired, maintenance performed, and products migrated with minimal business impacts. Some capabilities, such as capacity-on-demand, automatically turn components on and off based on current needs.

Although the z14 platform is highly robust and even more so in a sysplex<sup>3</sup> environment, implementing the IBM Geographically Dispersed Parallel Sysplex™ (IBM GDPS®) family of solutions improves resilience in cases of unplanned failures, power outages, fire, or human error. The GDPS family of solutions provides additional tools to ensure Z availability, and mask or significantly reduce the effects of critical component outages or failures.

Using IBM HyperSwap® technology, I/O traffic can be seamlessly routed from disk subsystems that cannot service the I/O request to a second disk subsystem that can. Additionally, the GDPS/Active-Active solution can route workload from a server location that is experiencing problems to a second location that is operating well.

### 1.1.5 Accelerating digital transformation with agile service delivery

An effective DevOps solution breaks down existing development silos, unifies infrastructure platforms, and enables ongoing deliveries. z14 provides the scalable and secure infrastructure for enterprises that must rapidly create and deliver critical applications, while meeting agreed-on levels for quality, availability, regulatory compliance, and end-use expectations.

IBM DevOps for Z solutions operate from application understanding through deployment and management. In addition, DevOps for Z solutions gives you a single, cost-effective toolset to maintain and modernize valuable applications on both Z and distributed platforms.

For instance, Application Discovery and Delivery Intelligence helps development teams understand application interdependencies, complexity, and quality across platforms, environments, and languages. This ability gives your teams an edge in identifying potential API candidates, and provides insight about maintainability and complexity. As a result, the candidate API quality rises, and the user experience improves as well.

In addition, the z14 provides the infrastructure to support the mission-critical workloads of cloud services. The new high-performance processors, large memory, and enhanced access to data enable the z14 to integrate business transactions, operational data, and analytics into a single workflow.

The IBM z14 is designed as a strategic asset to power the API economy.<sup>4</sup> Using the API economy demands fortified clouds, which can be open, private, public, and hybrid. The z14 gives you the hardware platform necessary to support those clouds.

For Linux assets, Z platforms are optimized for open source software, enhanced scalability, and sharing, while focusing on business continuity to support cloud. For traditional z/OS-based assets, Z offerings provide intuitive tools to help developers speed Representational State Transfer (RESTful) API development.

No matter which asset class you choose, the z14 allows mobile and cloud application developers to incorporate z/OS business-critical data and transactions into their applications without needing to understand z/OS subsystems.

<sup>3</sup> Sysplex is a system clustering technique for high availability. For more information, see “High availability with Parallel Sysplex” on page 78.

<sup>4</sup> For more information about the API economy, see the [Reach new customers with the API economy](#) website.

## 1.1.6 Revolutionizing business processes

Blockchain is poised to revolutionize how industries do business. It is a technology for a new generation of transactional applications that establishes trust, accountability, and transparency while streamlining business processes.

In a blockchain network, members have access to a distributed, shared ledger that is *cryptographically* secure, updated by consensus, and becomes an immutable, indelible record of all *transactions*. The ledger functions as a single source of “truth”. Considering that blockchain is all about increasing trust in *business transactions*, it makes perfect sense to run blockchain for business on Z.

Depending on your business or regulatory policies, you can choose on-premises installation that is supported by IBM-certified Docker images that are running on Linux on IBM Z, or the IBM Blockchain on Bluemix® High Security Business Network (HSBN) service plan. HSBN is a fully managed blockchain service that is running in the IBM cloud. It delivers a secure, isolated compute environment that is ideally suited for workloads with sensitive data.

## 1.1.7 Blending open source and Z technologies

The right blend and balance of open source technologies, ISV tools, and IT platform is key to enable businesses and organizations to deliver change at a much quicker pace. To this end, IBM has created an ecosystem of clients, business partners, and ISVs who are engaging in an open source development community to bring the most important and most sought-after foundational open source technologies to its IT platforms. In addition, IBM is a member of many open-standard organizations and software governance consortia that help to shape the future of open source software.

The combination of a robust and securable hardware platform with the power of a Linux distribution can optimize the building, testing, and deploying of modern applications, and can accommodate scale-out clusters and scalable clouds.

The z14 provides a secure, massive capacity Linux platform that can be deployed as stand-alone, or side-by-side with z/OS or IBM z/VSE® environments on a single physical platform. Therefore, you can easily integrate Linux workloads on the z14 with z/OS and z/VSE solutions that will benefit from data and applications being tightly collocated with fast internal communication and improved availability.

Linux on IBM Z on the z14 uses pervasive encryption, which is a transparent protection envelope that secures data within the system. It gives you the performance and vertical scale that you need to meet the demands of your digital enterprise while controlling server sprawl costs. Combined with the integration benefits, Linux on IBM Z on the z14 allows you to deploy innovative new services or cognitive analytics and consolidate x86 workloads.

In addition, deploying Linux on the z14 can benefit your bottom line. Compared to virtualized x86 alternatives and public cloud solutions, the lower costs for administration and management, software licensing, business continuity, and floor space can reduce your total cost of ownership.

## 1.2 z14 technical description

The IBM z14, when compared to its predecessor (IBM z13®), offers several improvements, such as faster, more efficient, and redesigned high-frequency chips, additional granularity options, better availability, faster encryption, and enhanced on-demand options.

### 1.2.1 Technical highlights

The z14 is a highly scalable symmetric multiprocessor (SMP) system, and the architecture ensures continuity and upgradeability from the previous z13 and zEC12. Five z14 models are offered: M01, M02, M03, M04, and M05.

Table 1-1 shows the main technical enhancements in the z14 over its predecessor platforms.

Table 1-1 Technical highlights in the z14

Greater total system capacity and more subcapacity settings for central processors (CP). The IBM z/Architecture® ensures continuity and upgradeability from previous models.	Up to 170 characterizable processor units. Up to 33 CPs can have subcapacity settings.
Multi-core, single-chip modules running to help improve the execution of processor-intensive workloads.	5.2 GHz (14 nm FINFET Silicon-On-Insulator (SOI))
More real memory per system, ensuring high availability in the memory subsystem through use of proven redundant array of independent memory (RAIM) technology.	Up to 32 TB of addressable real memory per system.
A large fixed hardware system area (HSA) that is managed separately from client-purchased memory.	192 GB.
Proven technology (fifth-generation high frequency and third-generation out-of-order design) with a single-instruction, multiple-data (SIMD) processor that increases parallelism to accelerate analytics processing. In addition, simultaneous multithreading (SMT) increases processing efficiency and throughput and raises the number of instructions in flight.	
Processor cache structure improvements and larger cache sizes to help with more of today's demanding production workloads. The z14 offers these levels of cache: <ul style="list-style-type: none"> <li>▶ First-level cache (L1 private): 128 KB for instructions, 128 KB for data</li> <li>▶ Second-level cache (L2): 2 MB for instructions and 4 MB for data</li> <li>▶ Third-level cache (L3): 128 MB</li> <li>▶ Fourth-level cache (L4): 672 MB</li> </ul>	
Improved cryptographic functions and performance, achieved by having one dedicated cryptographic co-processor per processor unit.	
IBM zHyperLink Express is a short distance, Z I/O adapter designed for up to 5x lower latency than High Performance FICON for read requests.	
The channel subsystem is built for I/O resilience. The number of logical channel subsystems (LCSS), subchannel sets, and I/O devices are consistent with its predecessor platform, as is the number of logical partitions (LPARs).	<ul style="list-style-type: none"> <li>▶ Six LCSS</li> <li>▶ 85 LPARs</li> <li>▶ Four subchannel sets</li> <li>▶ 32,000 I/O devices per channel</li> </ul>

You can compare the z14 to the previous two IBM Z generations by using the [Compare IBM Z](#) tool.

To ensure a balanced and highly available system, the z14 includes these additional features and functions:

- ▶ Enhanced LPAR resource allocation algorithms for processor units and memory (16 TB per LPAR).
- ▶ IBM Virtual Flash Memory (VFM) can be used to handle paging workload spikes and can improve availability. VFM is the replacement for the Flash Express features (0402 and 0403), which were available on the zEC12 and z13.
- ▶ Next generation Crypto Express6S feature supports up to 85 domains.
- ▶ New CMPSC with Huffman Coding compression for faster expansion algorithms and reduced overhead.
- ▶ Guarded Storage Facility for improved Java performance by reducing program pauses during Java Garbage Collection.
- ▶ The 25GbE RoCE Express2 provides a technology refresh for RDMA over Converged Ethernet (RoCE) on IBM Z. This feature provides increased networking performance to take advantage of higher speed processors.
- ▶ Coupling Express Long Reach (LR) for coupling links that must extend up to 10 km (6.21 miles).
- ▶ Dynamic I/O for a standalone Coupling Facility (CF) is a means for activating a new or changed I/O configuration without disruption.
- ▶ zHyperLink Express with IBM DS8880 for extremely low latency.
- ▶ Next generation FICON Express16S+ provides benefits for workloads through improvements in the base technology.
- ▶ OSA-Express7S 25GbE meets increased networking performance demands that are driven by high speed processors and faster network-attached devices.
- ▶ Secure Service Container<sup>5</sup> to build and host highly secure virtual appliances.
- ▶ Air cooled systems, such as cooling radiators with N+1 redundant design.
- ▶ Support for ASHRAE Class A3 data centers.

The z14 is compared in Figure 1-2 on page 9 with previous Z platforms in the following key areas:

- ▶ Single-engine (1-Way) PCI<sup>6</sup>
- ▶ Number of processor units
- ▶ Memory
- ▶ System I/O bandwidth

<sup>5</sup> See "Secure Service Container" on page 70 for more information.

<sup>6</sup> Based on the processor capacity index (PCI). PCI values can be obtained from [Large Systems Performance Reference, SC28-1187](#).

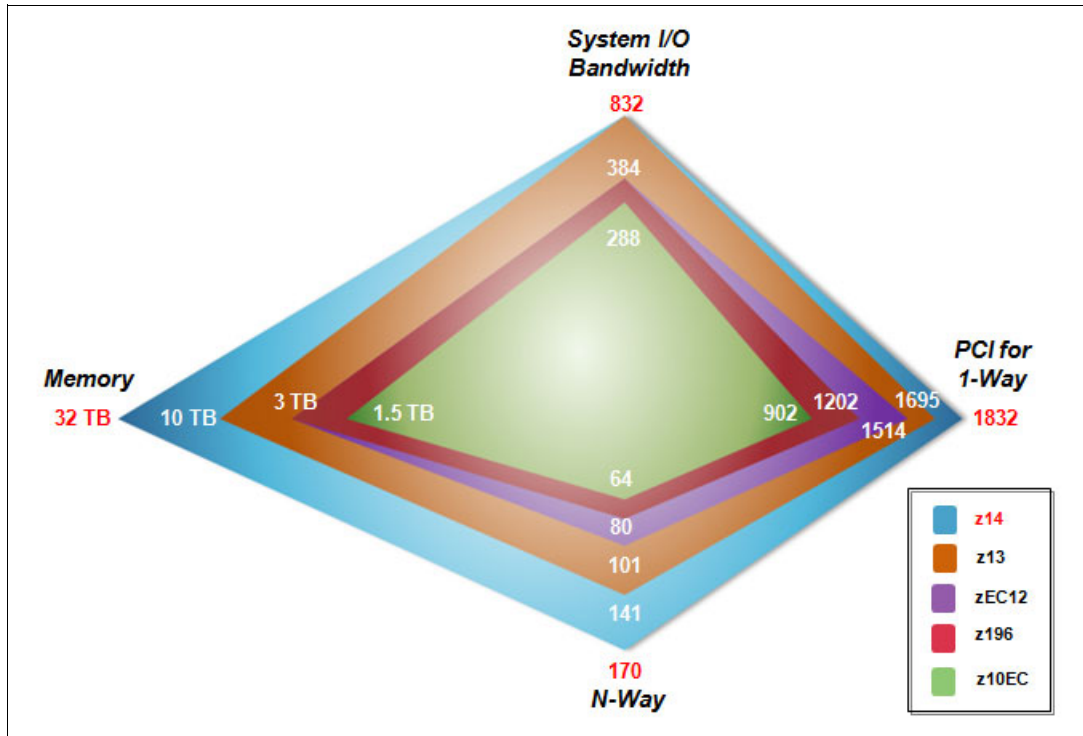

Figure 1-2 Balanced system design: z14 versus its predecessors

You can find more details about the z14 in Chapter 2, “IBM z14 hardware overview” on page 17. For an in-depth description of IBM z14 functions and features, see also [IBM z14 Technical Guide, SG24-8451](#).

## 1.2.2 Storage connectivity

Storage connectivity is provided on the z14 by IBM Fibre Connection (FICON) and the IBM zHyperLink Express feature.

### FICON Express

FICON Express features follow the established Fibre Channel (FC) standards to support data storage and access requirements, along with the latest FC technology in storage and access devices. FICON Express features support the following protocols:

- ▶ Native FICON

This enhanced protocol (over FC) provides for communication across channels, channel-to-channel (CTC) connectivity, and with FICON devices, such as disks, tapes, and printers. It is used in z/OS, IBM z/VM®, IBM z/VSE, z/TPF, and Linux on z Systems environments.

- ▶ Fibre Channel Protocol (FCP)

This is a standard protocol for communicating with disk and tape devices through Fibre Channel switches and directors. The FCP channel can connect to FCP SAN fabrics and access FCP/SCSI devices. FCP is used by z/VM, KVM for IBM Z, z/VSE, and Linux on z Systems environments.

FICON Express16S+ features provide significant improvements in throughput and response time for performance-critical middleware, and to shrink the batch window that is required to accommodate I/O-bound batch work. FICON Express16S+ features are implemented by using PCIe cards, and offer better port granularity and improved capabilities over the previous FICON Express features. FICON Express16S+ features support a link data rate of 16 Gbps (4, 8, or 16 Gbps auto-negotiate), and is the preferred technology for new systems.

For more information about the available FICON Express features, see 3.1, “I/O features at a glance” on page 32.

### **zHyperLink Express**

zHyperLink was created to provide fast access to data via extremely low latency connections between the Z platform and storage.

The zHyperLink Express feature allows you to make synchronous requests for data that is in the storage cache of the IBM DS8880. This process is done by directly connecting the zHyperLink Express port in the z14 to an I/O Bay port of the DS8880. This short distance (up to 150 m), direct connection is specifically designed for low latency reads and writes, such as with IBM Db2® logging.

Working with the FICON SAN Infrastructure, zHyperLink can improve application response time, cutting I/O-sensitive workload response time by up to 50% without requiring application changes.

**Note:** zHyperLink channels complement FICON channels, but they do *not* replace them.

For more information about the available FICON Express and zHyperLink Express features, see 3.3, “Storage connectivity” on page 36.

## **1.2.3 Network connectivity**

The z14 is a fully virtualized platform that can support many system images at once. Therefore, network connectivity covers not only the connections between the platform and external networks with Open Systems Adapter-Express (OSA-Express) and RoCE Express features, it supports specialized internal connections for intra-system communication through IBM HiperSockets™ and Shared Memory Communications–Direct Memory Access (SMC-D).

### **OSA-Express**

The OSA-Express features provide local area network (LAN) connectivity and comply with IEEE standards. In addition, OSA-Express features assume several functions of the TCP/IP stack that normally are performed by the processor unit, allowing significant performance benefits by offloading processing from the operating system.

OSA-Express6S features introduced with the z14 is a technology refresh. They continue to support 1000BASE-T Ethernet for copper environments and 10 Gigabit Ethernet and Gigabit Ethernet fiber optic (single-mode and multimode) environments. The OSA-Express7S 25GbE feature was added to support higher throughput by way of 25GbE network infrastructures.

### **HiperSockets**

IBM HiperSockets is an integrated function of the Z platforms that supplies attachments to up to 32 high-speed virtual local area networks with minimal system and network overhead.



HiperSockets is a function of the Licensed Internal Code (LIC). It provides LAN connectivity across multiple system images on the same Z platform by performing memory-to-memory data transfers in a secure way. The HiperSockets function eliminates the use of I/O subsystem operations and having to traverse an external network connection to communicate between logical partitions in the same Z platform. In this way, HiperSockets can help with server consolidation by connecting virtual servers and simplifying the enterprise network.

### **RoCE Express**

The 25GbE and 10GbE RoCE Express2 features use Remote Direct Memory Access (RDMA) over Converged Ethernet (RoCE) to provide fast memory-to-memory communications between two Z platforms.

Those features are designed to help reduce consumption of CPU resources for applications that use the TCP/IP stack (such as IBM WebSphere® that accesses an IBM Db2 database). They can also help reduce network latency with memory-to-memory transfers by using Shared Memory Communications over RDMA (SMC-R) in z/OS V2R1 or later.

With SMC-R, you can transfer huge amounts of data quickly, at low latency. SMC-R is completely transparent to the application, requiring no code changes and thus enabling rapid time to value.

### **SMC-D**

The z14 also uses the communications protocol called Shared Memory Communications-Direct Memory Access (SMC-D). SMC-D is similar to SMC-R, but is used for communications *within* the same Z platform. SMC-D optimizes operating systems communications in a way that is transparent to socket applications. It also reduces the CPU cost of TCP/IP processing in the data path, which enables highly efficient and application-transparent communications.

SMC-D requires no extra physical resources (such as RoCE Express features, PCIe bandwidth, ports, I/O slots, network resources, or Ethernet switches). Instead, SMC-D uses LPAR-to-LPAR communication through HiperSockets or an OSA-Express feature for establishing the initial connection.

For more information about the available network connectivity features, see 3.4, “Network connectivity” on page 40.

## **1.2.4 Cryptography**

z14 provides two major groups of cryptographic functions: CPACF and Crypto Express6S.

CPACF is a high performance, low latency co-processor that performs symmetric key encryption and calculates message digests (hashes) in hardware. Supported algorithms are AES, DES/TDES, SHA-1, SHA-2, and SHA-3. Latency in the CPACF in the z14 is significantly less compared to the CPACF in the z13.

The tamper-sensing and tamper-responding Crypto Express6S features provide acceleration for high-performance cryptographic operations and support up to 85 domains. This specialized hardware performs AES, DES/TDES, RSA, Elliptic Curve (ECC), SHA-1, and SHA-2, and other cryptographic operations. It supports specialized high-level cryptographic APIs and functions, including those required in the banking industry. Crypto Express6S features are designed to meet the FIPS 140-2 Level 4 and PCI HSM security requirements for hardware security modules.

The z14 offers twice the AES performance as the z13, a True Random Number Generator, SHA3 support, and RSA/ECC acceleration.

For more information about cryptographic features and functions, see 3.6, “Cryptographic features” on page 48.

## 1.2.5 Clustering connectivity

A Parallel Sysplex is an IBM Z clustering technology used to make applications running on logical and physical servers highly reliable and always available. The servers in a Parallel Sysplex are interconnected via coupling links.

Coupling connectivity for Parallel Sysplex on z14 use Coupling Express Long Reach (CE LR) Integrated Coupling Adapter Short Reach (ICA SR) and InfiniBand (IFB) technology. The ICA SR and HCA3-O SR are designed to support distances up to 150 m. The CE LR and HCA3-O LR fanouts supports longer unrepeated distances of up to 10 km between systems.

For information related to coupling and clustering features see 3.7, “Coupling and clustering” on page 50.

## 1.2.6 Special-purpose features and functions

When it comes to Z development, IBM takes a *total systems* view. The Z stack is built around digital services, agile application development, connectivity, and systems management. This configuration creates an integrated, diverse platform with specialized hardware and dedicated computing capabilities.

The z14 delivers a range of features and functions, allowing processor units to concentrate on computational tasks, while distinct, specialized features take care of the rest. The following are some of the special-purpose features and functions that are offered with the z14:

- ▶ Data compression
  - The Compression Coprocessor (CMPSC) is a high-performance coprocessor that uses compression algorithms (such as new Huffman encoding) to help reduce disk space and memory usage.
  - The IBM zEnterprise® Data Compression (zEDC) Express feature delivers an integrated solution to help reduce CPU consumption, optimize performance of compression-related tasks, and enable more efficient use of storage resources.
- ▶ Secure Services Container

This is a special-purpose firmware partition that is isolated from production and enables the secure deployment of software appliances.
- ▶ GDPS Virtual Appliance

The GDPS Virtual Appliance is a fully integrated, continuous availability, and disaster recovery solution for Linux on IBM Z that can help improve availability and time-to-value.
- ▶ Dynamic Partition Manager (DPM)

DPM is a guided management interface that is used to define the Z hardware and virtual infrastructure, including integrated dynamic I/O management that runs Linux on Z environments.

- ▶ **Guarded Storage Facility (GSF)**  
Also known as pause-less garbage collection, Guarded Storage Facility is a new architecture introduced with z14 to enable enterprise scale Java applications to run without periodic pause for garbage collection on larger heaps.
- ▶ **Instruction Execution Protection Facility (IEPF)**  
Instruction Execution Protection is a new hardware function introduced with z14 that enables software like IBM Language Environment® to mark certain memory regions (for example, a heap or stack) as non-executable to improve the security of programs running on Z against stack-overflow or similar attacks.
- ▶ **Simultaneous multithreading (SMT)**  
With SMT, you can process up to two simultaneous threads in a single core to optimize throughput. An operating system with SMT support can be configured to dispatch work to a thread on a zIIP<sup>7</sup> or an IFL<sup>8</sup>. New with z14, SAP engines also support SMT.
- ▶ **Single-instruction, multiple-data (SIMD)**  
SIMD is set of instructions that allows optimization of code to complex mathematical models and business analytics vector processing. The set of SIMD instructions are a type of data-parallel computing and vector processing that can decrease the amount of code and accelerate mathematical computations with integer, string, character, and floating point data types.
- ▶ **Dynamic memory relocation**  
This is in support of Enhanced Drawer Availability (EDA) and Concurrent Drawer Replacement (CDR). With this technology, an algorithm is used to dynamically move memory between CPC drawers to improve performance without impacting the operating system.
- ▶ **Coupling and parallel sysplex**  
Data sharing and serialization functions are offloaded to the coupling facility via a special coupling link network, providing the infrastructure to run a single production workload accessing a common set of data across many z/OS system images.

You can read more about these and other z14 features in Chapter 3, “Supported features and functions” on page 31 and Chapter 4, “Strengths of the z14 platform” on page 57.

## 1.2.7 Capacity on demand and performance

The z14 enables just-in-time deployment of processor resources. The capacity on demand (CoD) function allows users to dynamically change available system capacity. This function helps companies respond to new business requirements with flexibility and precise granularity.

Also contributing to the additional capacity on the z14 are numerous improvements in processor chip design, including new instructions, multithreading, and redesigned and larger caches.

In the same footprint, the z14 can deliver up to 25%<sup>9</sup> more capacity than the largest 141-way z13. The z14 1-way system has approximately 10% more capacity than the z13 1-way system.

<sup>7</sup> IBM z Integrated Information Processor (zIIP) is used under z/OS for designated workloads, which include IBM Java virtual machine (JVM), various XML System Services, and others.

<sup>8</sup> An Integrated Facility for Linux (IFL) is exclusively used with Linux on IBM Z and for running the z/VM or KVM hypervisor in support of Linux.

<sup>9</sup> Variations on all the observed increased performance depend on the workload type.

For more information, see 4.3.2, “Capacity on demand” on page 72 and 4.3.3, “z14 performance” on page 74.

## 1.2.8 Reliability, availability, and serviceability

The z14 offers the same high quality of service and *reliability, availability, and serviceability* (RAS) that is traditional in Z platforms. The RAS strategy employs a building-block approach that is designed to meet stringent client requirements for achieving continuous, reliable operation. These are the RAS building blocks:

- ▶ Error prevention
- ▶ Error detection
- ▶ Recovery
- ▶ Problem determination
- ▶ Service structure
- ▶ Change management
- ▶ Measurement
- ▶ Analysis

The RAS design objective is to manage change by learning from previous product releases and investing in new RAS functionality to eliminate or minimize all sources of outages.

For more information about RAS, see 4.4, “Reliability, availability, and serviceability” on page 76.

## 1.3 Software support

The z14 supports a wide range of IBM and independent software vendor (ISV) software solutions. This range includes traditional batch and online transaction processing (OLTP) environments, such as IBM Customer Information Control System (IBM CICS®), IBM Information Management System (IBM IMS™), and IBM DB2. It also includes these web services (in addition to others that are not listed):

- ▶ Java platform
- ▶ Linux and open standards applications
- ▶ WebSphere
- ▶ IBM MobileFirst® Platform Foundation for mobile application development
- ▶ IBM z/OS Connect Enterprise Edition

The following operating systems are supported on the z14:

- ▶ z/OS Version 2 Release 3
- ▶ z/OS Version 2 Release 2 with PTFs (exploitation)
- ▶ z/OS Version 2 Release 1 with PTFs (exploitation)
- ▶ z/OS Version 1 Release 13 with PTFs (limited exploitation, requires extended support)
- ▶ z/VM Version 7 Release 1
- ▶ z/VM Version 6 Release 4 with PTFs (compatibility and exploitation support)
- ▶ z/VSE Version 6 Release 2 with PTFs
- ▶ z/VSE Version 6 Release 1 with PTFs
- ▶ z/VSE Version 5 Release 2 with PTFs
- ▶ z/TPF Version 1 Release 1 (compatibility support)

- ▶ Linux on Z:
  - SUSE: SUSE Linux Enterprise Server 11 and 12
  - Red Hat: Red Hat Enterprise Linux (RHEL) 6, and RHEL7
  - Ubuntu: 16.04 LTS
- ▶ KVM hypervisor, which is offered with the following Linux distributions:
  - SLES-12 SP2 or higher
  - Ubuntu 16.04 LTS or higher.

Detailed service levels will be identified during toleration tests. For more information about recommended distribution levels, see [IBM tested and supported Linux environments](#).

For more information about the z14 software support, see Chapter 5, “Operating system support” on page 85.

### 1.3.1 IBM compilers

Compilers are built with specific knowledge of the system architecture, which is used during code generation. Therefore, using the latest compilers is essential to extract the maximum benefit of a platform’s capabilities. IBM compilers use the latest architecture enhancements and new instruction sets to deliver additional value.

With IBM Enterprise COBOL for z/OS and IBM Enterprise PL/I for z/OS, decades of IBM experience in application development can be used to integrate COBOL and PL/I with web services, XML, and Java. Such interoperability makes it possible to capitalize on existing IT investments, while smoothly incorporating new, web-based applications into the infrastructure.

z/OS, XL C/C++, and XL C/C++ for Linux on IBM Z help with creating and maintaining critical business applications that are written in C or C++ to maximize application performance and improve developer productivity. These compilers transform C or C++ source code into executable code that fully leverages the Z architecture. This transformation is possible thanks to hardware-tailored optimizations, built-in functions, performance-tuned libraries, and language constructs that simplify system programming and boost application runtime performance.

Compilers such as COBOL, PL/I, and z/OS v2.3 XL C/C++ are inherently optimized on the IBM z14 because they use floating point registers rather than memory or fast mathematical computations. Using compilers that take advantage of hardware enhancements is key to improving application performance, reducing CPU usage, and lowering operating costs.

The IBM z14 also offers release-to-release improvements for Java. Combined with cryptography acceleration, the z14 can deliver improvements in throughput per core. The new z14 pause-less garbage collection capability provides improvements in throughput per core as well. Because of shorter, more consistent Java response times, the z14 achieves both improvements without significantly affecting overall throughput. So for Java applications that must remain highly responsive, enabling the new garbage collection mode is a good option.





## IBM z14 hardware overview

This chapter expands on the description of the key hardware elements of the z14 that was presented in Chapter 1, “The base of a trust economy” on page 1. It includes the following topics:

- ▶ 2.1, “Models and upgrade paths” on page 18
- ▶ 2.2, “Frames and cabling” on page 19
- ▶ 2.3, “CPC drawers” on page 21
- ▶ 2.4, “I/O system structure” on page 27
- ▶ 2.5, “Power and cooling” on page 29

## 2.1 Models and upgrade paths

The z14 has an assigned machine type (MT) of 3906, which uniquely identifies the central processor complex (CPC). The z14 is offered in five models (M01, M02, M03, M04, and M05<sup>1</sup>). All z14 models use seven, eight, nine, or ten processor unit cores in five or six processor unit single chip modules in one CPC drawer. Spare processor units, system assist processors (SAPs), and one integrated firmware processor (IFP) are integral to the system and are present in all models of the z14.

Table 2-1 provides a summary that includes the number of characterizable processor units, SAPs, and spare processor units for the various models. For an explanation of processor unit characterization, see “PU characterization” on page 24.

Table 2-1 z14 model summary (machine type 3906)

Model	CPC drawers	Characterizable processor units	Standard SAPs	Spares	Integrated firmware processor
M01	1	1 - 33	5	2	1
M02	2	1 - 69	10	2	1
M03	3	1 - 105	15	2	1
M04	4	1 - 141	20	2	1
M05	4	1 - 170	23	2	1

The z14 offers 269 capacity levels. There are 170 capacity levels based on the number of physically used central processors (CPs), plus up to 99 additional subcapacity models for the first 33 CPs. There is also one model for all Integrated Facility for Linux (IFL) or all Internal Coupling Facility (ICF) configurations.

<sup>1</sup> The M05 is a new build order only model. You cannot upgrade from an M01, M02, M03, or M04 to an M05.



Figure 2-1 depicts the upgrade paths to the z14.



Figure 2-1 z14 upgrade paths

On the z14, concurrent upgrades (as described in Chapter 4, “Strengths of the z14 platform” on page 57) are available for CPs, IFLs, ICFs, IBM Z Integrated Information Processors (zIIPs), and SAPs. However, concurrent processor unit upgrades require that more processor units are physically installed, but not activated at a previous time.

If an upgrade request cannot be accomplished in the existing configuration, a hardware upgrade is required in which one or more CPC drawers are added to accommodate the wanted capacity. On the z14, additional CPC drawers can be installed concurrently. However, upgrading from any z14 model to model M05 is disruptive because this upgrade is only supplied as a new system.

Spare processor units are used to replace defective processor units and there are always two spare processor units on a z14. In the rare event of a processor unit failure, one of the spare processor units is immediately and transparently activated and assigned the characteristics of the failing processor unit.

## 2.2 Frames and cabling

The z14 is always a two-frame system: The *A Frame* and the *Z Frame*. It can be delivered as an air-cooled system or as a water-cooled one.

The two frames form the z14. The number of PCIe drawers can vary based on the number of I/O features. For a new build system, a combination of up to five PCIe I/O drawers can be installed. PCIe I/O drawers can be added concurrently.

In addition, the z14 (both new builds and MES orders) offers top-exit options for the fiber optic and copper cables used for I/O and power. These options (*Top Exit Power* and *Top Exit I/O Cabling*) give you more flexibility in planning where the system resides, potentially freeing you from running cables under a raised floor and increasing air flow over the system.

The radiator-cooled z14 models support installation on raised floor and non-raised floor environments. For water-cooled models, only the raised floor option is available.

Figure 2-2 shows an internal, front view of the two frames of an air-cooled z14 system with the maximum five PCIe I/O drawers, including the top-exit I/O and power cable options.

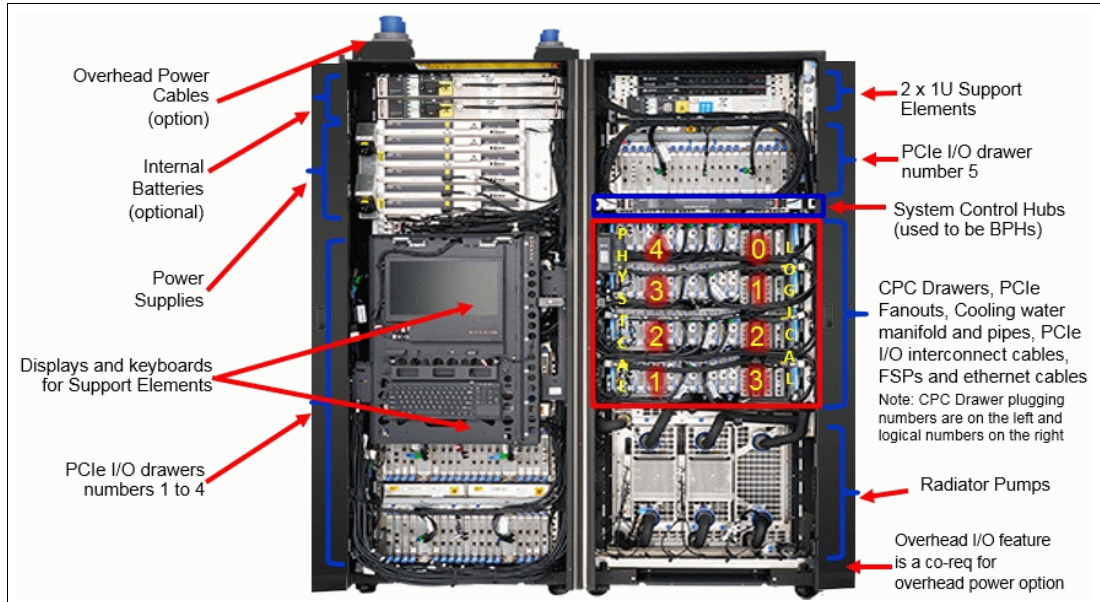

Figure 2-2 z14 internal, front view: Air-cooled platform with five PCIe I/O drawers

Figure 2-3 shows an internal, front view of the two frames of a water-cooled platform without the top exit I/O and power cable options.

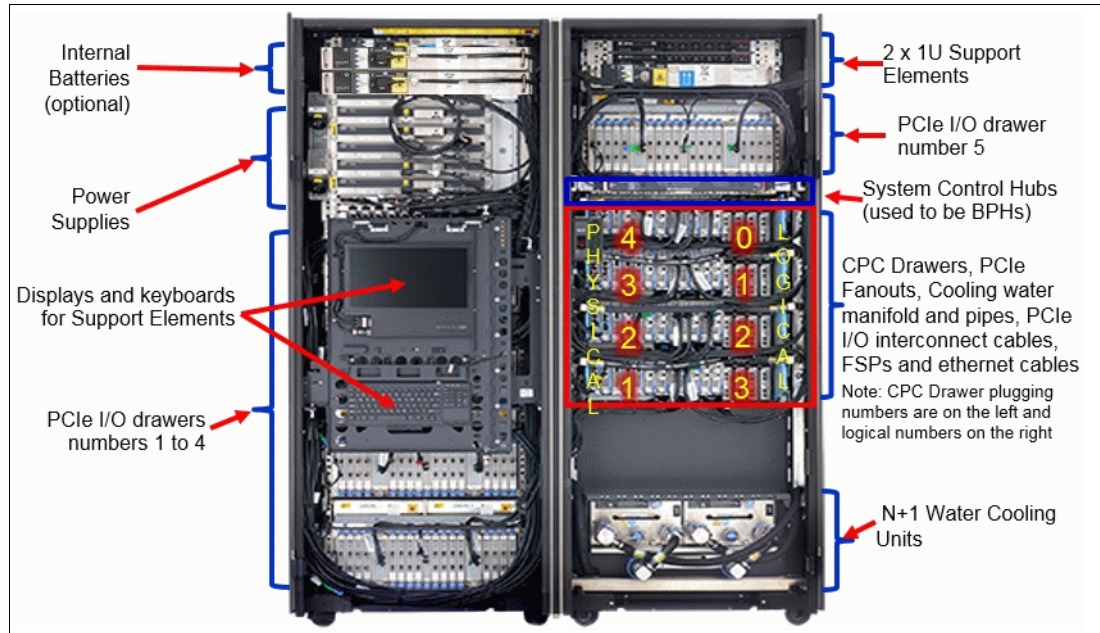

Figure 2-3 z14 internal, front view: Water-cooled platform with five PCIe I/O drawers

## 2.3 CPC drawers

The z14 is a multiple CPC drawer system that can hold up to four drawers in the A Frame.

Each CPC drawer contains the following elements:

- ▶ Single chip modules:
  - Five or six PU single chip modules, each containing seven, eight, nine, or ten processor unit cores (water-cooled).
  - One storage controller single chip module, with a total of 672 MB L4 cache.

Single chip modules are described in 2.3.1, “Single chip modules” on page 22. Also, see Table 2-1 on page 18 for the model summary and the relation between the number of CPC drawers and number of available processor units.
- ▶ Memory:
  - A minimum of 320 GB and a maximum of 32 TB of memory (excluding 192 GB HSA) is available for client use. See Table 2-2 on page 25 for details.
  - Either 15, 20, or 25 memory DIMMs are plugged in a CPC drawer.
- ▶ Fanouts:
 

The CPC drawer provides up to 10 PCIe Gen3 fanout adapters to connect to the PCIe I/O drawers and ICA SR coupling links, and up to four InfiniBand fanout adapters for 12x InfiniBand and 1x InfiniBand coupling links.

Each fanout has one, two, or four ports:

- One-port PCIe 16 GBps I/O fanout, each supporting one domain in 32-slot PCIe I/O drawers.
- ICA SR two-port PCIe fanout for coupling links (two links, 8 GBps each).
- HCA3-O 12x InfiniBand fanout for coupling links (two ports at 6 GBps each).
- HCA3-O LR 1x InfiniBand fanout for coupling links (four ports, 5 Gbps each).
- ▶ Two Distributed Converter Assemblies (DCAs) that provide power to the CPC drawer.
  - Loss of one DCA leaves enough power to satisfy the power requirements of the entire drawer. The DCAs can be concurrently maintained.
- ▶ Two Flexible Support Processors (FSPs) that provide redundant interfaces to the internal management network.

As shown in Figure 2-4, all CPC drawers are interconnected with high-speed communications links through the L4 shared caches. The z14 has 672 MB of L4 cache per CPC drawer.

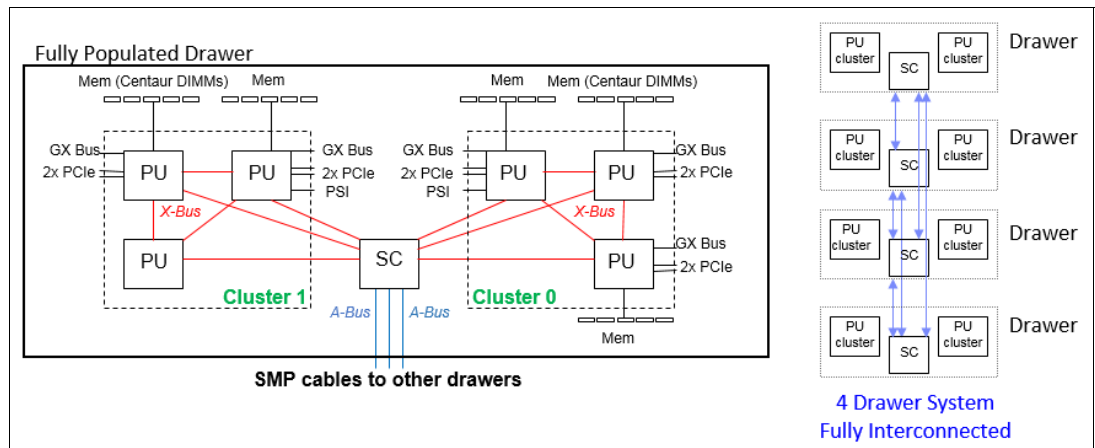

Figure 2-4 z14 CPC drawer communication topology

The design used to connect the processor unit and storage control allows the system to be operated and controlled by the IBM Processor Resource/Systems Manager™ (PR/SM™) facility as a memory-coherent symmetrical multiprocessor (SMP) system.

### 2.3.1 Single chip modules

A CPC drawer has five PU single chip modules (SCMs) for models M01 through M04 or six PU SCMs for model M05, and one storage control (SC) SCM. Each PU SCM has seven, eight, nine, or ten active PU cores, and L1, L2, and L3 caches. The SC SCM holds the L4 cache.

Figure 2-5 on page 23 shows the logical cluster structure for a model M05, showing the 6 PU SCMs, the SC SCM, and their connections. For models M01 through M04, the PU SCM to the far left in Logical Cluster 1 is not present. The number of PU cores on each of the PU SCMs can range from 7 to 10 for all models.

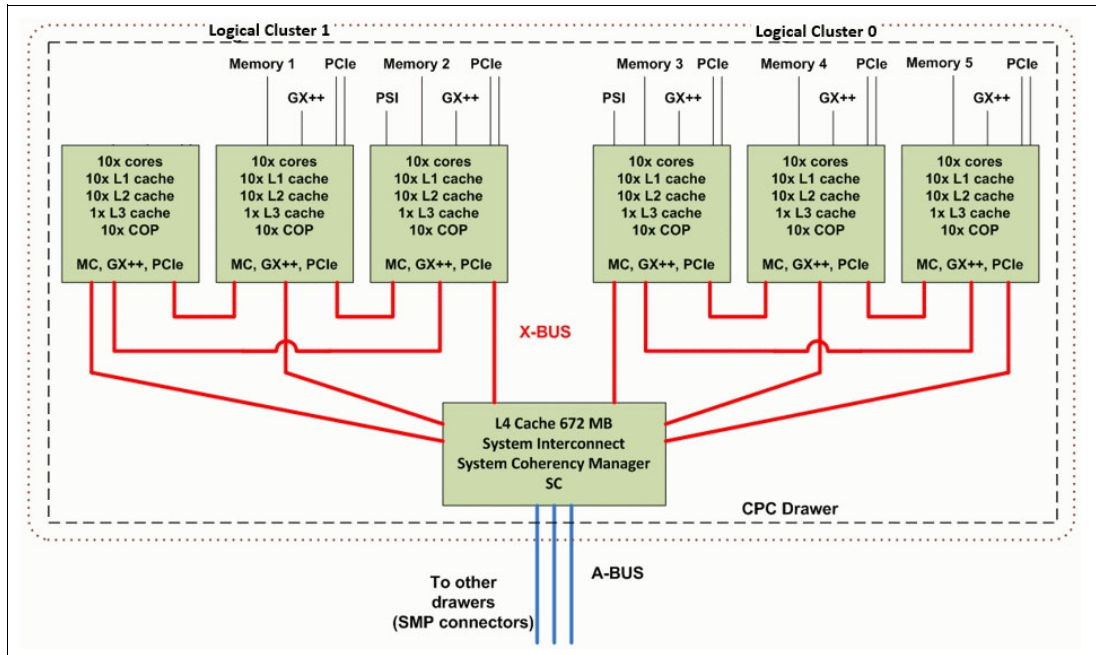

Figure 2-5 z14 M05 CPC drawer structure

For z14, two CPC drawer configurations are offered with 41 or 49 processor units. All the models employ CPC drawers with 41 processor units except for the model M05, which has four CPC drawers with 49 active processor units, for a total of 196 processor units (170 can be configured for use).

Each storage control SCM includes 672 MB shared eDRAM cache, interface logic for up to six PU SCM each, and SMP fabric logic. The SC SMC is configured to provide a single 672 MB L4 cache that is shared by all PU cores in the CPC drawer. This amount of cache provides a total of 2.68 GB of cache if all four CPC drawers are implemented, yielding outstanding SMP scalability for real-world workloads.

### 2.3.2 Processor unit

Processor unit (PU) is the generic term for a IBM z/Architecture processor. Each PU is a superscalar processor with the following attributes:

- ▶ Up to six instructions can be decoded per clock cycle.
- ▶ Up to ten instructions can be in execution per clock cycle.
- ▶ Instructions can be issued out-of-order. The PU uses a high-frequency, low-latency pipeline, providing robust performance across a wide range of workloads.
- ▶ Memory accesses might not be in the same instruction order (out-of-order operand fetching).
- ▶ Most instructions flow through a pipeline with varying numbers of steps for different types of instructions. Several instructions can be in execution at any moment, subject to the maximum number of decodes and completions per cycle.

## PU cache

The on-chip cache for the PU (core) works in this way:

- ▶ Each PU core has an L1 cache (private) that is divided into a 128 KB cache for instructions and a 128 KB cache for data.
- ▶ Each PU core has a private L2 cache, with 4 MB D-cache (“D” stands for data) and 2 MB I-cache (“I” stands for instruction).
- ▶ Each PU SCM contains a 128 MB L3 cache that is shared by all PU cores in the SCM. The shared L3 cache uses eDRAM.

This on-chip cache implementation optimizes system performance for high-frequency processors, with cache improvements, new Translation/TLB2 design, pipeline optimizations, and better branch prediction.

## PU sparing

Hardware fault detection is embedded throughout the design, and is combined with comprehensive instruction-level retry and dynamic PU sparing. This function provides the reliability and availability that is required for true mainframe integrity.

## On-chip cryptographic hardware

Dedicated on-chip cryptographic hardware for each PU core includes extended key and hash sizes for the Advanced Encryption Standard (AES) and Secure Hash Algorithm (SHA), and support for UTF8 to UTF16 conversion. This cryptographic hardware is available with any processor type, for example CP, IBM zIIP, and IFL.

## Software support

The z14 PUs provide full compatibility with existing software for z/Architecture, and extend the Instruction Set Architecture (ISA) to enable enhanced functionality and performance. Several hardware instructions that support more efficient code generation and execution are introduced in the z14:

- ▶ CP Assist for Cryptographic Functions (CPACF)
- ▶ Compression call (CMPSC)
- ▶ Hardware decimal floating point (HDFP)
- ▶ Transactional Execution Facility
- ▶ Runtime Instrumentation Facility
- ▶ Single-instruction, multiple-data (SIMD)

These features are further described in Chapter 4, “Strengths of the z14 platform” on page 57.

## PU characterization

PUs are ordered in single increments. The internal system functions, which are based on the configuration that is ordered, characterize each PU into one of various types during system initialization, which is often called a power-on reset (POR) operation. Characterizing PUs dynamically without a POR is possible by using a process called *Dynamic Processor Unit Reassignment*. A PU that is not characterized cannot be used. Each PU can be characterized as follows:

- ▶ Central processor (CP)
- ▶ Integrated Facility for Linux (IFL) processor
- ▶ IBM Z Integrated Information Processor (zIIP)
- ▶ Internal Coupling Facility (ICF)
- ▶ System assist processor (SAP)
- ▶ Integrated firmware processor (IFP)

At least one CP must be purchased with a zIIP or before a zIIP can be purchased. You can purchase up to two zIIPs for each purchased CP (assigned or unassigned) on the system. However, an LPAR definition can go beyond the 1:2 ratio. For example, on a system with two CPs, a maximum of four zIIPs can be installed. An LPAR definition for that system can contain up to two logical CPs and four logical zIIPs. Another possible configuration is one logical CP and three logical zIIPs.

Converting a PU from one type to any other type is possible by using the *Dynamic Processor Unit Reassignment* process. These conversions happen concurrently with the operation of the system.

**zIIPs:** The addition of ICFs, IFLs, zIIPs, and SAP to the z14 does not change the system capacity setting or its MSU rating.

### 2.3.3 Memory

Maximum physical memory size is directly related to the number of CPC drawers in the system. An IBM Z platform has more memory installed than was ordered because part of the installed memory is used to implement the redundant array of independent memory (RAIM) design. With the z14, up to 8 TB of memory per CPC drawer can be ordered and up to 32 TB for a four-CPC drawer system.

Table 2-2 lists the maximum memory sizes for each z14 model.

Table 2-2 z14 memory per model

Model	CPC drawers	Maximum memory
M01	1	8 TB
M02	2	16 TB
M03	3	24 TB
M04	4	32 TB
M05	4	32 TB

**Important:** z/OS V2R3 requires a minimum of 8 GB of memory (2 GB of memory when running under z/VM). z/OS can support up to 4 TB of memory in an LPAR.

The hardware system area (HSA) on the z14 has a fixed amount of memory (192 GB) that is managed separately from client memory. However, the maximum amount of orderable memory can vary from the theoretical number due to dependencies on the memory granularity. On z14 platforms, the granularity for memory are in 64 GB, 128 GB, 256 GB, and 512 GB increments.

Physically, memory is organized in the following ways:

- ▶ A CPC drawer always contains a minimum of 320 GB of installed memory, of which 256 GB is usable by the operating system.
- ▶ A CPC drawer can have more installed memory than is enabled. The excess memory can be enabled by a Licensed Internal Code load.



- ▶ Memory upgrades are first satisfied using already installed but unused memory capacity until it is exhausted. When no more unused memory is available from the installed cards, either the cards must be upgraded to a higher capacity, or a CPC drawer with more memory must be installed.

When an LPAR is activated, PR/SM tries to allocate processor units (PUs) and the memory of an LPAR in a single CPC drawer. However, if that is not possible, PR/SM will use memory resources located in any CPC drawer. For example, if the allocated PUs span more than one CPC drawer, PR/SM attempts to allocate memory across that same set of CPC drawers (even if all required memory is available in just one of those CPC drawers).

No matter which CPC drawer the memory is in, an LPAR has access to that memory after it is allocated. Despite the CPC drawer structure, the z14 is still an SMP system because the PUs have access to all the available memory.

A memory upgrade is considered to be concurrent when it requires no change of the physical memory cards. A memory card change is disruptive when no use is made of Enhanced Drawer Availability (EDA). In a multiple CPC drawer system, a single CPC drawer can be concurrently removed and reinstalled for a repair with EDA.

For model upgrades involving the addition of a CPC drawer, the minimum usable memory increment (256 GB) is added to the system. During an upgrade, adding a CPC drawer is a concurrent operation, as is adding physical memory in the new drawer.

### **Concurrent memory upgrade**

If physical memory is available, memory can be upgraded concurrently by using Licensed Internal Code Configuration Control (LICCC), as described. The *plan ahead memory function* that is available with the z14 enables nondisruptive memory upgrades by having in the system pre-plugged memory (based on a target configuration). Pre-plugged memory is enabled through an LICCC order that is placed by the client.

### **Redundant array of independent memory**

RAIM technology makes the memory subsystem, in essence, a fully fault-tolerant N+1 design. The RAIM design automatically detects and recovers from failures of dynamic random access memory (DRAM), sockets, memory channels, or dual inline memory modules (DIMMs).

The RAIM design is fully integrated in the z14, and has been enhanced to include one Memory Controller Unit (MCU) per processor chip, with five memory channels and one DIMM per channel. A fifth channel in each MCU enables memory to be implemented as RAIM. This technology has significant reliability, availability, and serviceability (RAS) capabilities in the area of error correction. Bit, lane, DRAM, DIMM, socket, and complete memory channel failures, including many types of multiple failures, can be detected and corrected.

For more information about memory design and configuration options, see [IBM z14 Technical Guide, SG24-8451](#).

## **2.3.4 Hardware system area**

The HSA is a fixed-size, reserved area of memory that is separate from the client-purchased memory. The HSA is used for several internal functions, but the bulk of it is used by channel subsystem functions.

The fixed-size 192 GB HSA for z14 is large enough to accommodate any LPAR definitions or changes, thus eliminating most outage situations and the need for extensive preplanning.



A fixed, large HSA allows the dynamic I/O capability of the z14 to be enabled by default. It also enables the dynamic addition and removal of the following features:

- ▶ LPAR to new or existing channel subsystem (CSS)
- ▶ CSS (up to six can be defined in z14)
- ▶ Subchannel set (up to four can be defined in z14)
- ▶ Devices, up to the maximum number permitted, in each subchannel set
- ▶ Logical processors by type
- ▶ Cryptographic adapters

## 2.4 I/O system structure

The z14 supports the Generation 3 PCIe-based infrastructure for PCIe I/O drawers (PCIe Gen3) type of internal I/O infrastructure.

The PCIe I/O infrastructure consists of the PCIe Gen3 fanouts in the CPC drawers that support 16 GBps connectivity to the PCIe I/O drawer.

The InfiniBand I/O infrastructure (carry forward only) consists of the InfiniBand fanouts in the z14 CPC drawer support for 12x InfiniBand and 1x InfiniBand coupling links.

**Ordering of I/O features:** Ordering of I/O feature types determines the appropriate number of PCIe I/O drawers. *InfiniBand I/O drawers are not supported on z14.*

Figure 2-6 shows a high-level view of the I/O system structure for the z14.

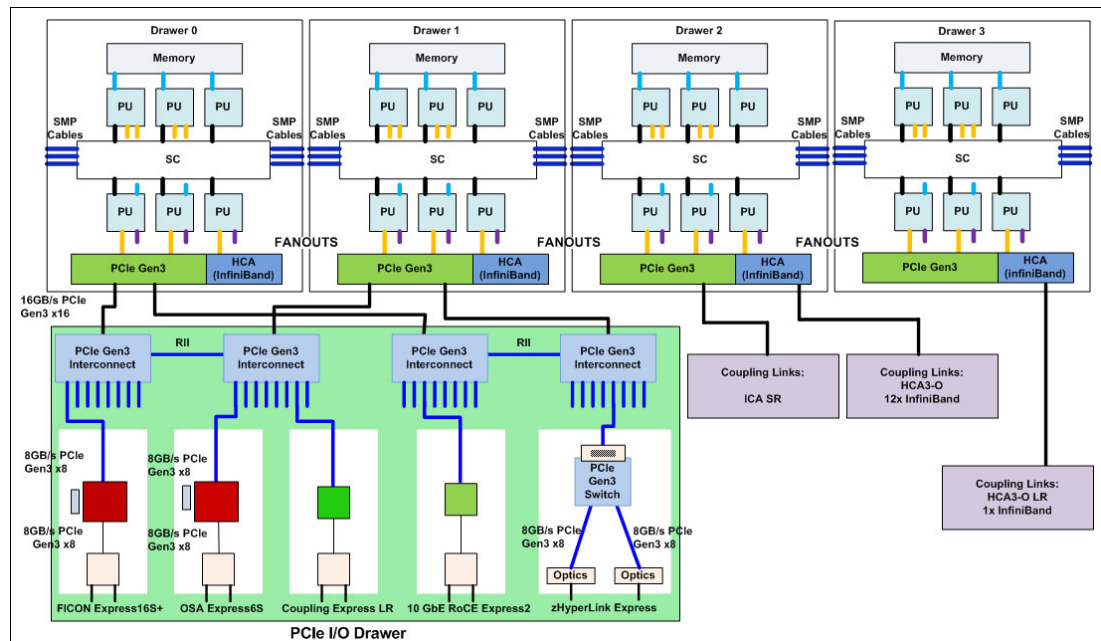

Figure 2-6 z14 I/O system structure

The z14 supports four fanout types (for fanout location, see Figure 2-7), which are at the front of the CPC drawer:

- ▶ ICA SR
- ▶ HCA3-O (z14 is the last Z platform to support this feature)
- ▶ HCA3-O LR (z14 is the last Z platform to support this feature)
- ▶ PCIe Gen3

The HCA3-O LR fanout includes four ports. The PCIe Gen3 fanout has one port, and the other fanouts have two ports.

The PCIe connections to the PCIe I/O drawers type of internal I/O connectivity support the PCIe I/O drawer.

For coupling link connectivity (Parallel Sysplex and STP configuration), the z14 supports the following link types:

- ▶ ICA SR
- ▶ 12x InfiniBand coupling link
- ▶ 1x InfiniBand coupling link
- ▶ Coupling Express LR

The z14 CPC drawer (see Figure 2-7) can have up to 10 1-port PCIe Gen3 or 2-port ICA PCIe coupling fanouts (numbered LG03 to LG12) and up to four 2-port or 4-port InfiniBand coupling fanouts for each CPC drawer (numbered LG13 to LG16). All coupling fanouts support Parallel Sysplex connectivity.

For systems with multiple CPC drawers, the locations of the PCIe Gen3 fanouts are configured and plugged across all drawers installed for maximum availability. This configuration helps ensure that alternate paths maintain access to critical I/O devices, such as disks and networks.

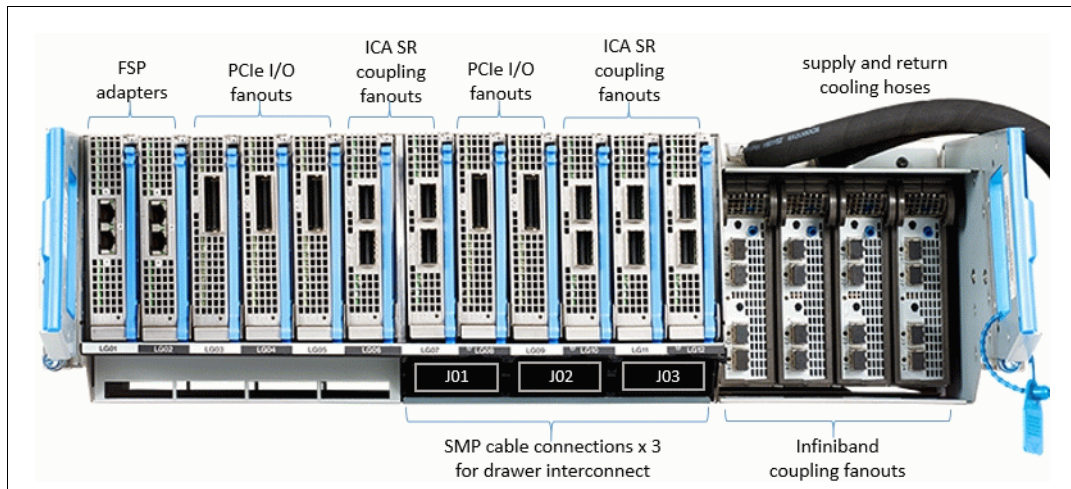

Figure 2-7 z14 CPC drawer, front view

The PCIe I/O drawer (see Figure 2-8) is a two-sided drawer that is 7U high. I/O features can be installed in both sides. The drawer contains 32 slots, four switch cards (two in the front and two in the rear). These features support four I/O domains that each contain eight features of any of the following types:

- ▶ FICON Express16S+, FICON Express16S, FICON Express8S
- ▶ OSA-Express7S, OSA-Express6S, OSA-Express5S, OSA-Express4S
- ▶ Crypto Express6S, Crypto Express5S

- ▶ zEDC Express
- ▶ 25GbE RoCE Express2, 10GbE RoCE Express2, 10GbE RoCE Express
- ▶ zHyperLink Express
- ▶ Coupling Express LR)

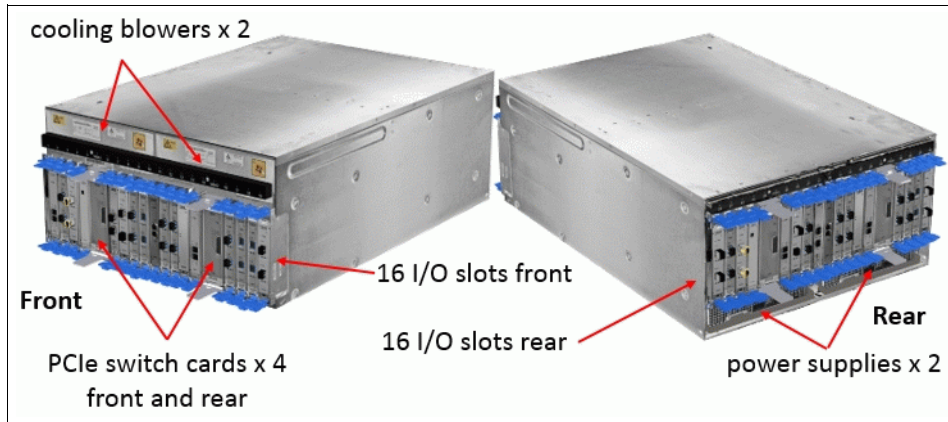

Figure 2-8 PCIe I/O drawer - front and rear views

Two DCAs provide redundant power, and two air moving devices (AMDs) provide redundant cooling to the PCIe I/O Drawer.

More details about the supported I/O features of the z14 are available in Chapter 3, “Supported features and functions” on page 31.

## 2.5 Power and cooling

The z14 meets the American Society of Heating, Refrigerating, and Air-Conditioning Engineers (ASHRAE) Class A3 specifications. [ASHRAE](#) is an organization that is devoted to the advancement of indoor-environment-control technology in the heating, ventilation, and air conditioning industry.

The power and cooling system of the z14 builds on that of its predecessor, the IBM z13, with several newly developed technologies. However, the underlying power service specifications of the z14 are almost identical to its predecessors. Total power consumption with the maximum system configuration has increased only by about 5% compared to those previous models.

A closed, internal water cooling loop is used to cool single chip modules in the CPC drawers of the z14. Extracting the heat from the internal water loop can be done either with a radiator (air-cooled system) or a water cooling unit (water-cooled system). Conversion from air to water cooled systems, and vice versa, is not available.

### 2.5.1 Radiator (air) cooling option

The cooling system in the z14 is redesigned for better availability and lower cooling power consumption. The radiator design is a closed-loop water cooling pump system for the single chip modules in the CPC drawers. It is designed with N+1 pumps, blowers, controls, and sensors. The radiator unit is cooled by air.

## 2.5.2 Water cooling option

The z14 continues to offer the choice of using a building's chilled water to cool the system by employing water cooling unit (WCU) technology. The single chip modules in the CPC drawer are cooled by an internal, closed, water cooling loop. In the internal closed loop, water exchanges heat with building-chilled water (provided by the client) through a cold plate.

In addition to the single chip modules, the internal water loop also circulates through two heat exchangers that are in the path of the exhaust air in the rear of the frames. These heat exchangers remove approximately 60-65% of the residual heat from the I/O drawers.

The z14 operates with two fully redundant WCUs. One WCU can support the entire load, and replacement of a WCU is fully concurrent. During a total loss of building-chilled water or if both water cooling units fail, the rear door heat exchangers cool the internal water cooling loop.

## 2.5.3 High Voltage Direct Current power feature

With the optional High Voltage Direct Current (HV DC) power feature, the z14 can directly connect to DC power input and improve data center energy efficiency by removing the need for an extra DC-to-AC inversion step. This feature can help achieve both data center UPS and power distribution energy savings.

## 2.5.4 Power considerations

The z14 operates with two sets of redundant power supplies. Each set has its own individual power cords or pair of power cords, depending on the number of Bulk Power Regulator (BPR) pairs installed. Power cords attach a 3-phase, 50/60 Hz, 200 - 480 V AC power source or 380 - 520 V DC power source. The loss of just one power supply has no effect on system operation.

The optional Balanced Power Plan Ahead feature is available for future growth, also assuring adequate and balanced power for all possible configurations. With this feature, downtime for upgrading a system is eliminated because the initial installation includes the maximum power requirements in terms of BPRs and power cords. The Balance Power Plan Ahead feature is not available with DC and 1-phase power cords.

Additional single-phase outlets (customer provided) are required for ancillary equipment such as the Hardware Management Console and its display.

Specific power requirements depend on the cooling facility that is installed, the number of CPC drawers, and the number and type of I/O units that are installed. You can find maximum power consumption tables for the various configurations and environments in [IBM 3906 Installation Manual for Physical Planning, GC28-6965](#).

You can also refer to the power and weight estimation tool that is available at [IBM Resource Link®](#).



## Supported features and functions

This chapter describes the I/O and other miscellaneous features and functions of the z14. The information in this chapter expands upon the overview of the key hardware elements provided in Chapter 2, “IBM z14 hardware overview” on page 17. Only the enhanced features and functions introduced with the z14 are discussed more in detail. The remaining supported features from earlier generations of Z platforms are listed for convenience.

Throughout the chapter, reference is made to the *IBM z14 Technical Guide*, SG24-8451.

This chapter includes the following topics:

- ▶ 3.1, “I/O features at a glance” on page 32
- ▶ 3.2, “Native PCIe features and integrated firmware processor” on page 35
- ▶ 3.3, “Storage connectivity” on page 36
- ▶ 3.4, “Network connectivity” on page 40
- ▶ 3.5, “Compression options” on page 48
- ▶ 3.6, “Cryptographic features” on page 48
- ▶ 3.7, “Coupling and clustering” on page 50
- ▶ 3.8, “Virtual Flash Memory” on page 52
- ▶ 3.9, “Server Time Protocol” on page 53
- ▶ 3.10, “Hardware Management Console and Support Element” on page 54

## 3.1 I/O features at a glance

The z14 supports a PCIe-based infrastructure for PCIe I/O drawers to support the following I/O features:

- ▶ zHyperLink Express
- ▶ FICON Express16S+
- ▶ FICON Express16S (carry forward only)
- ▶ FICON Express8S (carry forward only)
- ▶ OSA-Express7S
- ▶ OSA-Express6S
- ▶ OSA-Express5S (carry forward only)
- ▶ OSA-Express4S (carry forward only)
- ▶ 25GbE RoCE Express2
- ▶ 10GbE RoCE Express2
- ▶ 10GbE RoCE Express (carry forward only)
- ▶ Coupling Express Long Reach
- ▶ Crypto Express6S
- ▶ Crypto Express5S (carry forward only)
- ▶ zEnterprise Data Compression

The following clustering and coupling links are supported on the z14:

- ▶ Integrated Coupling Adapter - Short Reach (ICA SR)
- ▶ Host Channel Adapter3 - Optical Long Reach (HCA3-O LR)
- ▶ Host Channel Adapter3 - Optical (HCA3-O)

The following features that were part of earlier Z platforms are *not orderable* for the z14:

- ▶ ESCON
- ▶ FICON Express8 and older
- ▶ OSA-Express3 and older
- ▶ ISC-3
- ▶ Crypto Express4S and older
- ▶ Flash Express

Connector type LC Duplex is used for all fiber optic cables except those for the zHyperLink Express, HCA3-O (12x IFB), and ICA SR connections, which have multi-fiber push-on (MPO) connectors. The MPO connector of the HCA3-O (12x IFB) connection has one row of 12 fibers. The MPO connector of the zHyperLink Express and the ICA connection have two rows of 12 fibers, and are interchangeable.

The following pages list the supported features along with required cable types, maximum unrepeated distance, and bit rates. Tables for different purposes are provided and divided into the following sections:

- ▶ Table 3-1, "Storage connectivity features" on page 33
- ▶ Table 3-3, "Network connectivity features" on page 34
- ▶ Table 3-4, "Coupling and clustering features" on page 34
- ▶ Table 3-5, "Special-purpose features" on page 35

Storage connectivity options are listed in Table 3-1. More detailed information about zHyperLink, FICON, and FCP connectivity in relation to the z14 can be found in 3.3, “Storage connectivity” on page 36.

Table 3-1 Storage connectivity features

Feature	Feature codes	Bit rate in Gbps (or stated)	Cable type	Maximum unrepeated distance	Ordering information
zHyperLink Express	0431	8 Gbps	OM4, OM5	150 m	New build
			OM3	100 m	
FICON Express16S+ 10KM LX	0427	4, 8, or 16	SM 9 μm	10 km (6.2 miles)	New build
FICON Express16S+ SX	0428	4, 8, or 16	OM2, OM3, and OM4	See Table 3-2	New build
FICON Express16S 10KM LX	0418	4, 8, or 16	SM 9 μm	10 km (6.2 miles)	Carry forward
FICON Express16S SX	0419	4, 8, or 16	OM2, OM3, and OM4	See Table 3-2	Carry forward
FICON Express8S 10KM LX	0409	2, 4, or 8	SM 9 μm	10 km (6.2 miles)	Carry forward
FICON Express8S SX	0410	2, 4, or 8	OM2, OM3, and OM4	See Table 3-2	Carry forward

Table 3-2 shows the maximum unrepeated distances for different multimode fiber optic cable types when used with FICON SX (shortwave) features running at different bit rates.

Table 3-2 Unrepeated distances for different multimode fiber optic cable types

Cable type (Modal bandwidth)	2 Gbps	4 Gbps	8 Gbps	16 Gbps
OM1 (62.5 μm at 200 MHz·km)	150 meters	70 meters	21 meters	N/A
	492 feet	230 feet	69 feet	N/A
OM2 (50 μm at 500 MHz·km)	300 meters	150 meters	50 meters	35 meters
	984 feet	492 feet	164 feet	115 feet
OM3 (50 μm at 2000 MHz·km)	500 meters	380 meters	150 meters	100 meters
	1640 feet	1247 feet	492 feet	328 feet
OM4 (50 μm at 4700 MHz·km)	N/A	400 meters	190 meters	125 meters
	N/A	1312 feet	623 feet	410 feet

The network connectivity options are listed in Table 3-3. More detailed information about OSA-Express and RoCE Express connectivity in relation to the z14 can be found in 3.4, “Network connectivity” on page 40.

Table 3-3 Network connectivity features

Feature	Feature codes	Bit rate in Gbps (or stated)	Cable type	Maximum unrepeated distance <sup>a</sup>	Ordering information
OSA-Express7S 25GbE SR	0429	25	MM 50 μm	70 m (2000) 100 m (4700)	New build
OSA-Express6S 10 GbE LR	0424	10	SM 9 μm	10 km (6.2 miles)	New build
OSA-Express5S 10 GbE LR	0415				Carry forward
OSA-Express6S 10 GbE SR	0425	10	MM 62.5 μm	33 m (200)	New build
OSA-Express5S 10 GbE SR	0416		MM 50 μm	82 m (500) 300 m (2000)	Carry forward
OSA-Express6S GbE LX	0422	1.25	SM 9 μm	5 km (3.1 miles)	New build
OSA-Express5S GbE LX	0413				Carry forward
OSA-Express6S GbE SX	0423	1.25	MM 62.5 μm	275 m (200)	New build
OSA-Express5S GbE SX	0414		MM 50 μm	550 m (500)	Carry forward
OSA-Express6S 1000BASE-T	0426	100 or 1000 Mbps	Cat 5, Cat 6 unshielded twisted pair (UTP)	100 m	New build
OSA-Express5S 1000BASE-T	0417	10, 100, or 1000 Mbps			Carry forward
OSA-Express4S 1000BASE-T	0408				Carry forward
25GbE RoCE Express2	0430	25	MM 50 μm	70 m (2000) 100 m (4700)	New build
10GbE RoCE Express2	0412	10	MM 62.5 μm	33 m (200) 82 m (500)	New build
10GbE RoCE Express	0411		MM 50 μm	300 m (2000)	Carry forward

a. Where applicable, the minimum fiber bandwidth distance in MHz-km for multi-mode fiber optic links is included in parentheses.

Coupling link options are shown in Table 3-4. For more detailed information about the parallel sysplex or STP only link connectivity in relation to the z14, see 3.7, “Coupling and clustering” on page 50 and 3.9, “Server Time Protocol” on page 53.

Table 3-4 Coupling and clustering features

Feature	Feature codes	Bit rate	Cable type	Maximum unrepeated distance	Ordering information
CE LR	0433	10 Gbps	SM 9 μm	10 km (6.2 miles)	New build
ICA SR	0172	8 GBps	OM4	150 m	New build or Carry forward
			OM3	100 m	



Feature	Feature codes	Bit rate	Cable type	Maximum unrepeated distance	Ordering information
HCA3-O (12x IFB)	0171	6 GBps	OM3	150 m	Carry forward
HCA3-O LR (1x IFB)	0170	2.5 or 5 Gbps	SM 9 µm	10 km (6.2 miles)	
Internal Coupling (IC)	No coupling link feature or fiber optic cable required				

Table 3-5 provides information about special purpose features like cryptographic or compression features, and Virtual Flash Memory. More information about the cryptographic features is provided in 3.6, “Cryptographic features” on page 48.

Table 3-5 Special-purpose features

Feature	Feature codes	Bit rate in Gbps	Cable type	Maximum unrepeated distance	Ordering information
Crypto Express6S	0893	N/A	N/A	N/A	New build
Crypto Express5S	0890	N/A	N/A	N/A	Carry forward
zEDC Express	0420	N/A	N/A	N/A	New build or Carry forward
Virtual Flash Memory	0604	N/A	N/A	N/A	New build

## 3.2 Native PCIe features and integrated firmware processor

The zEC12 introduced feature types, known as native PCIe features, that require a different management design compared to the other I/O features. The following native PCIe features are available on the z14:

- ▶ zHyperLink Express
- ▶ Coupling Express Long Reach (CE LR)
- ▶ 25GbE RoCE Express2
- ▶ 10GbE RoCE Express2
- ▶ 10GbE RoCE Express
- ▶ zEDC Express

These features are plugged exclusively into a PCIe I/O drawer, where they coexist with the other, non-native PCIe, I/O adapters, and features. However, they are managed in a different way from those other I/O adapters and features. The native PCIe feature cards have a PCHID assigned according to the physical location in the PCIe I/O drawer.

For the native PCIe features supported by z14, drivers are included in the operating system, and the adaptation layer is not needed. The adapter management functions (such as diagnostics and firmware updates) are provided by Resource Groups partitions running on the integrated firmware processor (IFP). The z14 has four Resource Groups compared to two for the z13 and zEC12.

The IFP is used to manage native PCIe adapters installed in a PCIe I/O drawer. The IFP is allocated from a pool of processor units that are available for the whole system. Because the IFP is exclusively used to manage native PCIe adapters, it is not taken from the pool of processor units that can be characterized for customer usage.

If a native PCIe feature is present in the system, the IFP is initialized and allocated during the system POR phase. Although the IFP is allocated to one of the physical processor units, it is not visible. In case of error or failover scenarios, the IFP acts like any other processor unit (that is, sparing is started).

## 3.3 Storage connectivity

IBM is constantly investing in new and existing technologies to help their clients in investment protection and bring new values to them. In the storage connectivity area, the focus is on improving the latency for I/O transmission.

With the introduction of zHyperLink Express for the z14, IBM ensures the optimization of the Z I/O infrastructure.

In the FICON technology IBM introduced with the z14 the next generation of FICON features. This new FICON Express 16S+ feature is exclusive to the z14 and offers the same functions as its predecessor, the FICON Express16S feature, with increased performance.

For more information about FICON channel, see the [Z I/O connectivity website](#). Technical papers about performance data are also available.

### 3.3.1 zHyperLink Express

IBM zHyperLink Express is a new, short distance, Z I/O adapter designed for up to 5x lower latency than High Performance FICON for read requests. This feature resides in the PCIe I/O drawer and is a two-port adapter used for short distance, direct connectivity between a z14 and a DS8880. It uses PCIe Gen3 technology, with x16 lanes that are bifurcated into x8 lanes for storage connectivity. The zHyperLink Express is designed to support distances up to 150 meters (492 feet) at a link data rate of 8 GigaBytes per second (GBps).

A 24x MTP-MTP cable is required for each port of the zHyperLink Express feature. It is single 24-fiber cable with Multi-fiber Termination Push-on (MTP) connectors. Internally, the single cable houses 12 fibers for transmit and 12 fibers for receive.

Note that FICON connectivity to each storage system is still required. The FICON connection is used for zHyperLink initialization, I/O requests that are not eligible for zHyperLink communications, and as an alternative path should zHyperLink requests fail (for example, storage cache misses or busy storage device conditions).

### 3.3.2 FICON functions

FICON features continue to evolve, delivering improved throughput, reliability, availability, and serviceability (RAS). FICON features in the z14 can provide connectivity to systems, Fibre Channel (FC) switches, and various devices in a SAN environment. The FICON protocol is fully supported on the z14. It is commonly used with IBM z/OS, IBM z/VM (and guest systems), IBM z/VSE, and IBM z/TPF. The next subsections describe the FICON enhancements.

#### **FICON multi-hop and cascaded switch support**

The z14 supports three hops (up to four FC switches) in a cascaded switch configuration. This support can help simplify the infrastructure with optimized RAS functionality. The support for a FICON multi-hop environment must also be provided by the FC switch vendor.

## High Performance FICON for IBM Z (zHPF)

High Performance FICON for IBM Z (zHPF) is implemented for protocol simplification and efficiency, which it does by reducing the number of information units (IU) that are processed. Enhancements to the z/Architecture and the FICON protocol provide optimizations for online transaction processing (OLTP) workloads. zHPF can also be used by z/OS for IBM DB2, VSAM, PDSE, and zFS.

zHPF has been further enhanced to allow all large write operations greater than 64 KB to be run in a single round trip to the control unit at distances up to 100 km (62 miles). This enhancement does not elongate the I/O service for these write operations at extended distances. It is especially useful for IBM GDPS HyperSwap configurations.

Additionally, the changes to the architecture provide end-to-end system enhancements to improve reliability, availability, and serviceability (RAS).

zHPF requires matching support by the IBM System Storage® DS8880 series or similar devices from other vendors. FICON Express16S+, FICON Express16S, and FICON Express8S support the FICON protocol and the zHPF protocol in the server Licensed Internal Code.

## FICON Forward Error Correction

Even with proper fiber optic cable cleaning discipline, errors can still occur on 16 Gbps links. Forward Error Correction (FEC) is a technique used for controlling errors in data transmission over lower quality communication channels. With FEC, I/O errors are decreased, thus reducing potential impact on workload performance caused by I/O errors.

When running at 16 Gbps, FICON Express16S+ and FICON Express16S features can use FEC when connected to devices that support FEC, such as the IBM DS8880. FEC allows channels to operate at higher speeds, over longer distances, and with reduced power and higher throughput, while retaining the same reliability and robustness for which FICON channels have traditionally been known.

## FICON Dynamic Routing

FICON Dynamic Routing (FIDR) is designed to support the dynamic routing policies supplied by FICON Director providers, such as Brocade's Exchange Based Routing (EBR) and Cisco's Open Exchange ID Routing (OxID).

With FIDR, you are no longer restricted to using static storage area network (SAN) routing policies for inter-switch links (ISLs) in a cascaded FICON Directors configuration. Performance of both FICON and FCP traffic improve due to SAN dynamic routing policies that better use all of the available ISL bandwidth through higher utilization.

The IBM DS8880 also supports FIDR, so in a configuration with the z14, capacity planning and management can be simplified, and provide persistent and repeatable performance and higher resiliency.

All devices in the SAN environment must support FICON Dynamic Routing to take advantage of this feature.

The z14s continue to provide the functions that were introduced on other Z platforms with the supported FICON features. For more information, see [IBM Z Connectivity Handbook, SG24-5444](#).

### 3.3.3 FCP functions

Fibre Channel Protocol (FCP) is fully supported on the z14. It is commonly used with Linux on z Systems and supported by the z/VM and z/VSE. The next subsections describe the current FCP enhancements.

#### **N\_Port ID Virtualization**

N\_Port ID Virtualization (NPIV) is designed to allow the sharing of a single physical FCP channel among operating system images, whether in logical partitions or as z/VM guests. This goal is achieved by assigning a unique worldwide port name (WWPN) for each operating system that is connected to the FCP channel. In turn, each operating system appears to have its own distinct WWPN in the SAN environment, therefore enabling separation of the associated FCP traffic on the channel.

Access controls that are based on the assigned WWPN can be applied in the SAN environment. This function can be done by using standard mechanisms, such as zoning in SAN switches and logical unit number (LUN) masking in the storage controllers.

Several preferred and allowable operating characteristic values in the FCP protocol have increased:

- ▶ The preferred maximum number of NPIV hosts defined to any single physical FCP channel has increased from 32 to 64.
- ▶ The allowable maximum number of remote N\_Ports a single physical channel can communicate with has increased from 512 to 1024.
- ▶ The maximum number of LUNs addressable by a single physical channel has increased from 4096 to 8192.

In support of these increases, the FCP channels have also been designed to now support 1528 concurrent I/O operations, an increase from the prior generation FCP channel limit of 764.

#### **Export/import physical port WWPNs for FCP channels**

IBM Z platforms automatically assign WWPNs to the physical ports of an FCP channel, and this WWPN assignment changes when an FCP channel is moved to a different physical slot position in the I/O drawer. The z14 allows for the modification of these default assignments, permitting FCP channels to keep previously assigned WWPNs. This capability eliminates the need for reconfiguration of the SAN environment when a Z platform upgrade occurs or when a FICON Express feature is replaced.

#### **Fibre Channel Read Diagnostic Parameter**

An extended link service (ELS) command called Read Diagnostic Parameter (RDP) has been added to the Fibre Channel T11 standard to allow Z platforms to obtain additional diagnostic data from the Small Form-factor Pluggable (SFP) optics located throughout the SAN fabric. RDP can identify a failed or failing component without unnecessarily replacing more components in the SAN fabric (such as FICON features, optics, cables, and so on).

FICON and FCP channels provide a means to read this additional diagnostic data for all of the ports accessed in the I/O configuration and make the data available to a Z LPAR. For FICON channels, z/OS displays the data with a message and display command. For Linux on z Systems, z/VM, z/VSE, and KVM for IBM z, this diagnostic data is made available in a window in the SAN Explorer tool on the Hardware Management Console (HMC).

### 3.3.4 FICON Express16S+

Two types of transceivers for FICON Express16S+ are supported on a new build system: One long wavelength (LX) laser version, and one short wavelength (SX) laser version:

- ▶ FICON Express16S+ LX feature
- ▶ FICON Express16S+ SX feature

Each port supports attachment to the following elements:

- ▶ FICON/FCP switches and directors that support 4 Gbps, 8 Gbps, or 16 Gbps
- ▶ Control units (storage subsystems) that support 4 Gbps, 8 Gbps, or 16 Gbps

**Note:** Both ports must be the same CHPID type, that is either FC or FCP

#### FICON Express16S+ LX feature

The FICON Express16S LX feature occupies one I/O slot in the PCIe I/O drawer. It has two ports, each supporting an LC duplex connector and auto-negotiated link speeds of 4 Gbps, 8 Gbps, and 16 Gbps up to an unrepeated maximum distance of 10 km (6.21 miles).

#### FICON Express16S+ SX feature

The FICON Express16S SX feature occupies one I/O slot in the PCIe I/O drawer. It has two ports, each supporting an LC duplex connector and auto-negotiated link speeds of 4 Gbps, 8 Gbps, and 16 Gbps up to an unrepeated maximum distance<sup>1</sup> of 380 meters (1,246.7 feet) at 4 Gbps, 150 meters (492 feet) at 8 Gbps, or 100 meters (328 feet) at 16 Gbps.

### 3.3.5 FICON Express16S (carry forward only)

Two types of transceivers for FICON Express16S are available only when carried forward on upgrades. Two types of transceivers for FICON Express16S are supported on z14:

- ▶ FICON Express16S LX feature
- ▶ FICON Express16S SX feature

Each port supports attachment to the following elements:

- ▶ FICON/FCP switches and directors that support 4 Gbps, 8 Gbps, or 16 Gbps
- ▶ Control units (storage subsystems) that support 4 Gbps, 8 Gbps, or 16 Gbps

**Note:** To permit the mix of different CHPID types (FC and FCP), the keyword MIXTYPE must be defined in the IODF to at least one port of the card.

#### FICON Express16S LX feature

The FICON Express16S LX feature occupies one I/O slot in the PCIe I/O drawer. It has two ports, each supporting an LC duplex connector and auto-negotiated link speeds of 4 Gbps, 8 Gbps, and 16 Gbps up to an unrepeated maximum distance of 10 km (6.21 miles).

#### FICON Express16S SX feature

The FICON Express16S SX feature occupies one I/O slot in the PCIe I/O drawer. It has two ports, each supporting an LC duplex connector and auto-negotiated link speeds of 4 Gbps, 8 Gbps, and 16 Gbps up to an unrepeated maximum distance of 380 meters (1,246.7 feet) at 4 Gbps, 150 meters (492 feet) at 8 Gbps, or 100 meters (328 feet) at 16 Gbps.

<sup>1</sup> Distances are valid for OM3 cabling. See Table 3-5 on page 35 for more options.

### 3.3.6 FICON Express8S (carry forward only)

The FICON Express8S features are available only when carried forward on upgrades. Two types of transceivers for FICON Express8 are supported on z14:

- ▶ FICON Express8S 10KM LX feature
- ▶ FICON Express8S SX feature

#### **FICON Express8S 10KM LX feature**

The FICON Express8S 10KM LX feature occupies one I/O slot in the I/O drawer. It has four ports, each supporting an LC duplex connector, and auto-negotiated link speeds of 2 Gbps, 4 Gbps, and 8 Gbps up to an unrepeated maximum distance of 10 km (6.21 miles).

#### **FICON Express8S SX feature**

The FICON Express8S SX feature occupies one I/O slot in the I/O drawer. This feature has four ports, each supporting an LC duplex connector, and auto-negotiated link speeds of 2 Gbps, 4 Gbps, and 8 Gbps up to an unrepeated maximum distance of 500 meters (1,640 feet) at 2 Gbps, 380 meters (1,246.7 feet) at 4 Gbps, or 150 meters (492 feet) at 8 Gbps.

## 3.4 Network connectivity

The z14 offers a wide range of functions that can help consolidate or simplify the network environment. These include OSA-Express, RoCE-Express, and HiperSockets.

### 3.4.1 OSA-Express functions

Improved throughput (mixed inbound/outbound) is achieved by the data router function that was introduced in the OSA-Express3, and enhanced in OSA-Express6S and OSA-Express5S features. With the data router, the store and forward technique in DMA is no longer used. The data router enables a direct host memory-to-LAN flow. This function avoids a hop and is designed to reduce latency and to increase throughput for standard frames (1492 bytes) and jumbo frames (8992 bytes).

The following sections describe the most current OSA-Express functions.

#### **OSM CHPID for usage with Dynamic Partition Manager**

Dynamic Partition Manager (DPM) requires that the z14 has two OSA-Express5S 1000BASE-T Ethernet or OSA-Express6S 1000BASE-T Ethernet features that are defined as CHPID type OSM for connectivity. OSA-Express features that are defined with OSM cannot be shared with other CHPID types and must be dedicated for usage by DPM. DPM supports Linux on IBM Z that is running in an LPAR, under KVM hypervisor for IBM Z, or z/VM.

DPM can be ordered along with Ensemble Membership, but they cannot both be enabled at the same time on the system.

#### **OSA-ICC support for Secure Sockets Layer**

The Open Systems Adapter, when configured as an integrated console controller CHPID type (OSC) on the z14, supports the configuration and enablement of secure connections using the Transport Layer Security (TLS) protocol versions 1.0, 1.1, and 1.2. Server-side authentication is supported using either a self-signed certificate or customer supplied certificate, which can be signed by a customer-specified certificate authority.

The certificates used must have an RSA key length of 2048 bits, and must be signed by using SHA-256. This support negotiates a cipher suite of AES-128 for the session key.

### **Queued direct I/O optimized latency mode**

Queued direct I/O (QDIO) optimized latency mode can help improve performance for applications that have a critical requirement to minimize response times for inbound and outbound data. It optimizes the interrupt processing as noted in the following configurations:

- ▶ For inbound processing, the TCP/IP stack looks more frequently for available data to process, ensuring that any new data is read from the OSA-Express6S or OSA-Express5S without requiring more program-controlled interrupts.
- ▶ For outbound processing, the OSA-Express6S or OSA-Express5S looks more frequently for available data to process from the TCP/IP stack, thus not requiring a Signal Adapter instruction to determine whether more data is available.

### **Inbound workload queuing**

Inbound workload queuing (IWQ) can help to reduce overhead and latency for inbound z/OS network data traffic and implement an efficient way for initiating parallel processing. This improvement is achieved by using OSA-Express features in QDIO mode (CHPID type OSD) with multiple input queues, and by processing network data traffic that is based on workload types. The data from a specific workload type is placed in one of four input queues (per device). A process is created and scheduled to run on one of the multiple processors, independent from the other three queues. This change can improve performance because IWQ can use the symmetric multiprocessor (SMP) architecture of the Z.

### **Virtual local area network support**

Virtual local area network (VLAN) is a function of OSA-Express features that takes advantage of the Institute of Electrical and Electronics Engineers (IEEE) 802.q standard for virtual bridged LANs. VLANs allow easier administration of logical groups of stations that communicate as though they were on the same LAN. In the virtualized environment of the Z, TCP/IP stacks can exist, potentially sharing OSA-Express features. VLAN provides a greater degree of isolation by allowing contact with a server from only the set of stations that comprise the VLAN.

### **Virtual MAC support**

When sharing OSA port addresses across LPARs, Virtual MAC (VMAC) support enables each operating system instance to have a unique VMAC address. All IP addresses associated with a TCP/IP stack are accessible by using their own VMAC address, instead of sharing the MAC address of the OSA port. Advantages can include a simplified configuration setup and improvements to IP workload load balancing and outbound routing.

This support is available for Layer 3 mode, is used by z/OS, and is supported by z/VM for guest use.

### **z/VM multi-VSwitch link aggregation support**

z/VM V6.3 (with PTFs) or newer provides multi-VSwitch link aggregation support, allowing a port group of OSA-Express features to span multiple virtual switches within a single z/VM LPAR or between multiple z/VM LPARs. Sharing a link aggregation port group (LAG) with multiple virtual switches increases optimization and utilization of the OSA-Express when handling larger traffic loads. With this support, a port group is no longer required to be dedicated to a single z/VM virtual switch.

## QDIO data connection isolation for the z/VM environment

New workloads increasingly require multitier security zones. In a virtualized environment, an essential requirement is to protect workloads from intrusion or exposure of data and processes from other workloads.

The QDIO data connection isolation enables the following elements:

- ▶ Adherence to security and HIPPA-security guidelines and regulations for network isolation between the instances that share physical network connectivity.
- ▶ Establishment of security zone boundaries that are defined by the network administrators.
- ▶ A mechanism to isolate a QDIO data connection (on an OSA port) by forcing traffic to flow to the external network. This feature ensures that all communication flows only between an operating system and the external network.

Internal routing can be disabled on a per-QDIO connection basis. This support does not affect the ability to share an OSA port. Sharing occurs as it does today, but the ability to communicate between sharing QDIO data connections can be restricted through this support.

QDIO data connection isolation (also known as VSWITCH port isolation) applies to the z/VM environment when using the Virtual Switch (VSWITCH) function, and to all supported OSA-Express features (CHPID type OSD) on Z. z/OS supports a similar capability.

## QDIO interface isolation for z/OS

Some environments require strict controls for routing data traffic between servers or nodes. In certain cases, the LPAR-to-LPAR capability of a shared OSA port can prevent such controls from being enforced. With interface isolation, internal routing can be controlled on an LPAR basis. When interface isolation is enabled, the OSA discards any packets that are destined for a z/OS LPAR that is registered in the OAT as isolated.

QDIO interface isolation is supported by Communications Server for z/OS V1R11 and later, and for all supported OSA-Express features on Z.

### 3.4.2 OSA-Express7S

This section describes the connectivity option that is offered with the OSA-Express7S feature. The OSA-Express7S 25GbE Short Reach (SR) feature can be installed on z14.

The OSA-Express7S 25GbE SR feature occupies one slot in the PCIe+ I/O drawer. This feature includes one port that connects to a 25 Gbps Ethernet LAN through a 50 µm multimode fiber optic cable that ends with an LC Duplex connector.

The maximum supported unrepeatable distance is 100 meters (328 feet) with a 50 µm (at 4700 MHz·km) multimode fiber optic cable and 70 meters (229.6 feet) with a 50 µm (at 2000 MHz·km) multimode fiber optic cable.

### 3.4.3 OSA-Express6S

This section describes the connectivity options that are offered by the OSA-Express6S features. The following OSA-Express6S features can be installed on z14:

- ▶ OSA-Express6S 10 Gigabit Ethernet (GbE) Long Reach (LR)
- ▶ OSA-Express6S 10 Gigabit Ethernet (GbE) Short Reach (SR)
- ▶ OSA-Express6S Gigabit Ethernet Long Wavelength (GbE LX)
- ▶ OSA-Express6S Gigabit Ethernet Short Wavelength (GbE SX)
- ▶ OSA-Express6S 1000BASE-T Ethernet



### **OSA-Express6S 10 GbE LR feature**

The OSA-Express6S 10 GbE LR feature occupies one slot in a PCIe I/O drawer. It has one port that connects to a 10 Gbps Ethernet LAN through a 9  $\mu\text{m}$  single mode fiber optic cable that is terminated with an LC Duplex connector. The feature supports an unrepeatable maximum distance of 10 km (6.21 miles).

### **OSA-Express6S 10 GbE SR feature**

The OSA-Express6S 10 GbE SR feature occupies one slot in the PCIe I/O drawer. This feature has one port that connects to a 10 Gbps Ethernet LAN through a 62.5  $\mu\text{m}$  or 50  $\mu\text{m}$  multimode fiber optic cable that is terminated with an LC Duplex connector.

The maximum supported unrepeatable distance is 33 meters (108 feet) on a 62.5  $\mu\text{m}$  multimode fiber optic cable, and 300 meters (984 feet) on a 50  $\mu\text{m}$  multimode fiber optic cable.

### **OSA-Express6S GbE LX feature**

The OSA-Express6S GbE LX occupies one slot in the PCIe I/O drawer. This feature has two ports, representing one channel path identifier (CHPID), that connect to a 1 Gbps Ethernet LAN through a 9  $\mu\text{m}$  single mode fiber optic cable. This cable is terminated with an LC Duplex connector, supporting an unrepeatable maximum distance of 5 km (3.1 miles). A multimode (62.5 or 50  $\mu\text{m}$ ) fiber optic cable can be used with this feature. The use of these multimode cable types requires a Mode Conditioning Patch (MCP) cable at each end of the fiber optic link. Use of the single mode to multimode MCP cables reduces the supported distance of the link to a maximum of 550 meters (1,804 feet).

### **OSA-Express6S GbE SX feature**

The OSA-Express6S GbE SX occupies one slot in the PCIe I/O drawer. This feature has two ports, representing one CHPID, that connect to a 1 Gbps Ethernet LAN through 50 or 62.5  $\mu\text{m}$  multimode fiber optic cable. This cable is terminated with an LC Duplex connector over an unrepeatable distance of 550 meters (1,804 feet) for 50  $\mu\text{m}$  fiber or 220 meters (721.7 feet) for 62.5  $\mu\text{m}$  fiber.

### **OSA-Express6S 1000BASE-T feature**

The OSA-Express6S 1000BASE-T occupies one slot in the PCIe I/O drawer. It has two ports, representing one CHPID, that connect to a 1000 Mbps (1 Gbps) or 100 Mbps Ethernet LAN. Each port has an RJ-45 receptacle for UTP Cat5 or Cat6 cabling, which supports a maximum distance of 100 meters (328 feet).

**Note:** The OSA-Express6S 1000BASE-T feature will be the last generation to support connections operating at 100 Mbps link speed. Future OSA-Express 1000BASE-T features will support operation only at 1 Gbps link speed.

## **3.4.4 OSA-Express5S (carry forward only)**

This section describes the connectivity options that are offered by the OSA-Express5S features. The following OSA-Express5S features can be installed on z14:

- ▶ OSA-Express5S 10 Gigabit Ethernet (GbE) Long Reach (LR)
- ▶ OSA-Express5S 10 Gigabit Ethernet (GbE) Short Reach (SR)
- ▶ OSA-Express5S Gigabit Ethernet Long Wavelength (GbE LX)
- ▶ OSA-Express5S Gigabit Ethernet Short Wavelength (GbE SX)
- ▶ OSA-Express5S 1000BASE-T Ethernet

### **OSA-Express5S 10 GbE LR feature**

The OSA-Express5S 10 GbE LR feature occupies one slot in a PCIe I/O drawer. It has one port that connects to a 10 Gbps Ethernet LAN through a 9  $\mu\text{m}$  single mode fiber optic cable that is terminated with an LC Duplex connector. The feature supports an unrepeated maximum distance of 10 km (6.21 miles).

### **OSA-Express5S 10 GbE SR feature**

The OSA-Express5S 10 GbE SR feature occupies one slot in the PCIe I/O drawer. This feature has one port that connects to a 10 Gbps Ethernet LAN through a 62.5  $\mu\text{m}$  or 50  $\mu\text{m}$  multimode fiber optic cable that is terminated with an LC Duplex connector. The maximum supported unrepeated distance is 33 m on a 62.5  $\mu\text{m}$  multimode fiber optic cable, and 300 m on a 50  $\mu\text{m}$  multimode fiber optic cable.

### **OSA-Express5S GbE LX feature**

The OSA-Express5S GbE LX occupies one slot in the PCIe I/O drawer. This feature has two ports, representing one CHPID, that connect to a 1 Gbps Ethernet LAN through a 9  $\mu\text{m}$  single mode fiber optic cable. This cable is terminated with an LC Duplex connector, supporting an unrepeated maximum distance of 5 km (3.1 miles). A multimode (62.5 or 50  $\mu\text{m}$ ) fiber optic cable can be used with this feature. The use of these multimode cable types requires a MCP cable at each end of the fiber optic link. Use of the single mode to multimode MCP cables reduces the supported distance of the link to a maximum of 550 meters (1,804 feet).

### **OSA-Express5S GbE SX feature**

The OSA-Express5S GbE SX occupies one slot in the PCIe I/O drawer. This feature has two ports, representing one CHPID, that connect to a 1 Gbps Ethernet LAN through 50 or 62.5  $\mu\text{m}$  multimode fiber optic cable. This cable is terminated with an LC Duplex connector over an unrepeated distance of 550 meters (1,804 feet) for 50  $\mu\text{m}$  fiber or 220 meters (721.7 feet) for 62.5  $\mu\text{m}$  fiber.

### **OSA-Express5S 1000BASE-T feature**

The OSA-Express5S 1000BASE-T occupies one slot in the PCIe I/O drawer. It has two ports, representing one CHPID, that connect to a 1000 Mbps (1 Gbps) or 100 Mbps Ethernet LAN. Each port has an RJ-45 receptacle for UTP Cat5 or Cat6 cabling, which supports a maximum distance of 100 meters (328 feet).

## **3.4.5 OSA-Express4S (carry forward only)**

The OSA-Express4S features offer OSA-Express4S 1000BASE-T Ethernet connectivity options on a z14.

### **OSA-Express4S 1000BASE-T feature**

The OSA-Express4S 1000BASE-T occupies one slot in the PCIe I/O drawer. It has two ports, representing one CHPID, that connect to a 1000 Mbps (1 Gbps), 100 Mbps, or 10 Mbps Ethernet LAN. Each port has an RJ-45 receptacle for UTP Cat5 or Cat6 cabling, which supports a maximum distance of 100 meters (328 feet).

## **3.4.6 HiperSockets functions**

IBM HiperSockets has been referred to as the “network in a box” because it simulates LAN environments entirely in the hardware. The data transfer is from LPAR memory to LPAR memory, mediated by microcode. The z14 support up to 32 HiperSockets.

One HiperSockets network can be shared by up to 85 LPARs. Up to 4096 communication paths support a total of 12,288 IP addresses across all 32 HiperSockets.

The HiperSockets internal networks can support the following transport modes:

- ▶ Layer 2 (link layer)
- ▶ Layer 3 (network or IP layer)

Traffic can be Internet Protocol Version 4 or Version 6 (IPv4, IPv6) or non-IP (such as AppleTalk, DECnet, IPX, NetBIOS, SNA, or others). HiperSockets devices are independent of protocol and Layer 3. Each HiperSockets device has its own Layer 2 Media Access Control (MAC) address. This address is designed to allow the use of applications that depend on the existence of Layer 2 addresses such as Dynamic Host Configuration Protocol (DHCP) servers and firewalls.

Layer 2 support can help facilitate server consolidation. Complexity can be reduced, network configuration is simplified and intuitive, and LAN administrators can configure and maintain the mainframe environment the same way as they do for a non-mainframe environment. HiperSockets Layer 2 support is provided by Linux on IBM Z, and by z/VM for guest use.

The most current HiperSockets functions are described in the following sections.

### **HiperSockets Multiple Write Facility**

HiperSockets performance is enhanced to allow for the streaming of bulk data over a HiperSockets link between LPARs. The receiving LPAR can now process a much larger amount of data per I/O interrupt. This enhancement is transparent to the operating system in the receiving LPAR. HiperSockets Multiple Write Facility, with fewer I/O interrupts, reduces CPU use of the sending and receiving LPAR. The HiperSockets Multiple Write Facility is supported in the z/OS environment.

### **zIIP-Assisted HiperSockets for large messages**

In z/OS, HiperSockets are enhanced for zIIP usage. Specifically, the z/OS Communications Server allows the HiperSockets Multiple Write Facility processing for outbound large messages that originate from z/OS to be performed on a zIIP.

zIIP-Assisted HiperSockets can help make highly secure and available HiperSockets networking an even more attractive option. z/OS application workloads that are based on XML, HTTP, SOAP, Java, and traditional file transfer can benefit from zIIP enablement by lowering general-purpose processor use for such TCP/IP traffic.

When the workload is eligible, the TCP/IP HiperSockets device driver layer (write) processing is redirected to a zIIP, which unblocks the sending application.

### **HiperSockets network traffic analyzer**

HiperSockets network traffic analyzer (NTA) is a function that is available in the LIC of z Systems. It can simplify problem isolation and resolution by allowing Layer 2 and Layer 3 tracing of HiperSockets network traffic.

HiperSockets NTA allows Linux on z Systems to control tracing of the internal virtual LAN. It captures records into host memory and storage (file systems) that can be analyzed by system programmers and network administrators. These administrators can use Linux on z Systems tools to format, edit, and process the trace records.

A customized HiperSockets NTA rule enables authorizing an LPAR to trace messages only from LPARs that are eligible to be traced by the NTA on the selected IQD channel.

### **HiperSockets completion queue**

The HiperSockets completion queue function allows both synchronous and asynchronous transfer of data between logical partitions. With the asynchronous support, during high volume situations, data can be temporarily held until the receiver has buffers available in its inbound queue. This function can provide performance improvement for LPAR to LPAR communication, and can be especially helpful in burst situations.

### **HiperSockets virtual switch bridge support**

The z/VM virtual switch is enhanced to transparently bridge a guest virtual machine network connection on a HiperSockets LAN segment. This bridge allows a single HiperSockets guest virtual machine network connection to also directly communicate with the following systems:

- ▶ Other guest virtual machines on the virtual switch
- ▶ External network hosts through the virtual switch OSA UPLINK port

A HiperSockets channel by itself is only capable of providing intra-CPC communications. The HiperSockets Bridge Port allows a virtual switch to connect z/VM guests by using real HiperSockets devices, the ability to communicate with hosts that reside externally to the CPC. The virtual switch HiperSockets Bridge Port eliminates the need to configure a separate next hop router on the HiperSockets channel to provide connectivity to destinations that are outside of a HiperSockets channel.

## **3.4.7 Shared Memory Communications functions**

The Shared Memory Communication (SMC) capabilities of the z14 optimizes the communications between applications in server-to-server (SMC-R) or LPAR-to-LPAR (SMC-D) connectivity.

SMC-R provides application transparent use of the RoCE Express feature that can reduce the network overhead and latency of data transfers, effectively offering the benefits of optimized network performance across processors.

The Internal Shared Memory (ISM) virtual PCI function takes advantage of the capabilities of SMC-D. ISM is a virtual PCI network adapter that enables direct access to shared virtual memory, providing a highly optimized network interconnect for Z intra-system communications. Up to 32 channels for SMC-D traffic can be defined in a z14, whereby each channel can be virtualized to a maximum of 255 Function IDs<sup>2</sup>.

---

<sup>2</sup> The 10GbE RoCE features and the ISM adapters are identified by a hexadecimal Function Identifier (FID) with a range of 00 - FF.

### 3.4.8 RoCE Express features

This section describes the connectivity options that are offered by the Remote Direct Memory Access (RDMA) over Converged Ethernet (RoCE) Express features. The following RoCE features can be installed in the z14:

- ▶ 25GbE RoCE Express2
- ▶ 10GbE RoCE Express2
- ▶ 10GbE RoCE Express (carry forward only)

The RoCE Express features help reduce the use of CPU resources for applications that use the TCP/IP stack. It might also help to reduce network latency with memory-to-memory transfers that use SMC-R in z/OS V2R1 and later versions. It is transparent to applications, and can be used for server-to-server communication in a multiple Z platform environment.

These features are installed in the PCIe+ I/O drawer and use a short reach (SR) laser as the optical transceiver. Both point-to-point connections and switched connections with an Ethernet switch are supported. Ethernet switches must include the *Pause frame* enabled as defined by the IEEE 802.3x standard.

A maximum of *eight* features (any combination of 25GbE RoCE Express2, 10GbE RoCE Express2, or 10GbE RoCE Express features) can be installed in the z14.

**Note:** 25GbE RoCE Express2 should not be mixed with 10GbE RoCE Express2 or 10GbE RoCE Express in the same SMC-R link group. 10GbE RoCE Express2 can be mixed with 10GbE RoCE Express in the same SMC-R link group.

#### 25GbE RoCE Express2

The 25GbE RoCE Express2 feature occupies one slot in the PCIe+ I/O drawer. This feature includes two ports that connect to a 25 Gbps Ethernet LAN through a 50 µm multimode fiber optic cable that ends with an LC Duplex connector.

The maximum supported unrepeatd distance is 100 meters (328 feet) with an OM4 multimode fiber optic cable and 70 meters (229.6 feet) with an OM3 multimode fiber optic cable. The 25GbE RoCE Express2 supports 63 Virtual Functions (VFs)<sup>3</sup> per physical port for a total of 126 per adapter.

#### 10GbE RoCE Express2

The 10 Gigabit Ethernet (GbE) RoCE Express2 feature occupies one slot in the PCIe I/O drawer. This feature has two ports that connect to a 10 Gbps Ethernet LAN through a 62.5 µm or 50 µm multimode fiber optic cable that is terminated with an LC Duplex connector. The maximum supported unrepeatd distance is 300 meters (984 feet) on an OM3 multimode fiber optic cable, and can be increased to 600 meters (1,968 feet) when sharing a switch across two 10 GbE RoCE Express2 features. The 10GbE RoCE Express2 supports 63 Virtual Functions (VFs) per physical port for a total of 126 per adapter.

#### 10GbE RoCE Express (carry forward only)

The 10 Gigabit Ethernet (GbE) RoCE Express feature occupies one slot in the PCIe I/O drawer. This feature has two ports that connect to a 10 Gbps Ethernet LAN through a 62.5 µm or 50 µm multimode fiber optic cable that is terminated with an LC Duplex connector. The maximum supported unrepeatd distance is 300 m on an OM3 multimode fiber optic cable, and can be increased to 600 m when sharing a switch across two RoCE Express features. The RoCE Express supports 31 VFs per feature.

<sup>3</sup> Virtual Function ID is defined when PCIe hardware or the ISM is shared between LPARs.

## 3.5 Compression options

Two types of compression options are available with the z14: A standard internal compression coprocessor tightly connected to each processor unit, and an external native PCIe feature.

### 3.5.1 Compression Coprocessor

The Compression Coprocessor (CMPSC) is a well known feature that works in tight conjunction with the processor units in the Z. This coprocessor works with a proprietary compression format and is used for many types of z/OS data.

### 3.5.2 zEnterprise Data Compression

zEnterprise Data Compression (zEDC) Express is an optional native PCIe feature that is available in the z14. It provides hardware-based acceleration for data compression and decompression for the enterprise, which can help to improve cross platform data exchange, reduce CPU consumption, and save disk space.

A minimum of one feature can be ordered and a maximum of 16 can be installed on the system, in the PCIe I/O drawer. Up to two zEDC Express features per domain can be installed. There is one PCIe adapter/compression processor per feature that implements compression as defined by [RFC1951 \(DEFLATE\)](#). A zEDC Express feature can be shared between up to 31 LPARs.

## 3.6 Cryptographic features

The z14 provide cryptographic functions that, from an application program perspective, can be grouped as follows:

- ▶ Synchronous cryptographic functions, provided by the CP Assist for Cryptographic Function (CPACF) or the Crypto Express features when defined as an accelerator.
- ▶ Asynchronous cryptographic functions, provided by the Crypto Express features.

### 3.6.1 CP Assist for Cryptographic Function

CPACF offers a set of symmetric cryptographic functions for high-performance encryption and decryption with clear key operations for SSL/TLS, VPN, and data-storing applications that do not require FIPS 140-2 level 4 security<sup>4</sup>. The CPACF is an optional feature that is integrated with the compression unit in the coprocessor in the z14 microprocessor core.

The CPACF protected key is a function that facilitates the continued privacy of cryptographic key material while keeping the wanted high performance. CPACF ensures that key material is not visible to applications or operating systems during encryption operations. CPACF protected key provides substantial throughput improvements for large-volume data encryption and low latency for encryption of small blocks of data.

---

<sup>4</sup> Federal Information Processing Standards (FIPS) 140-2 Security Requirements for Cryptographic Modules

The cryptographic assist includes support for the following functions:

- ▶ Advanced Encryption Standard (AES) for 128-bit, 192-bit, and 256-bit keys
- ▶ Data Encryption Standard (DES) data encryption and decryption with single, double, or triple length keys.
- ▶ Pseudo-random number generation (PRNG)
- ▶ Message authentication code (MAC)
- ▶ Hashing algorithms: SHA-1, SHA-2, and SHA-3

SHA-1, SHA-2, and SHA-3 support are enabled on all Z platforms and do not require the CPACF enablement feature. The CPACF functions are supported by z/OS, z/VM, z/VSE, z/TPF, and Linux on z Systems.

See “Pervasive encryption” on page 82 regarding use of this function.

### 3.6.2 Crypto Express6S

The Crypto Express6S represents the newest generation of the Peripheral Component Interconnect® Express (PCIe) cryptographic coprocessors, an optional feature exclusive to the z14. These are Hardware Security Modules (HSMs) designed to provide high-security cryptographic processing as required by banking and other industries. This feature provides a secure programming and hardware environment wherein crypto processes are performed. Each cryptographic coprocessor includes general-purpose processors, non-volatile storage, and specialized cryptographic electronics, all contained within a tamper-sensing and tamper-responsive enclosure which destroys all keys and sensitive data on any attempt to tamper with the device. The security features of the HSM are designed to meet the requirements of FIPS 140-2, Level 4, the highest security level defined.

The Crypto Express6S has one PCIe adapter per feature. For availability reasons, a minimum of two features is required. Up to 16 Crypto Express6S features are supported. The Crypto Express6S feature occupies one I/O slot in a PCIe I/O drawer.

Each adapter can be configured as a Secure IBM CCA coprocessor, a Secure IBM Enterprise PKCS #11 (EP11) coprocessor, or as an accelerator.

Crypto Express6S provides domain support for up to 85 logical partitions.

The accelerator function is designed for maximum-speed Secure Sockets Layer and Transport Layer Security (SSL/TLS) acceleration, rather than for specialized financial applications for secure, long-term storage of keys or secrets. The Crypto Express6S can also be configured as one of the following configurations:

- ▶ The Secure IBM CCA coprocessor includes secure key functions with emphasis on the specialized functions required for banking and payment card systems. It is optionally programmable to add custom functions and algorithms by using User Defined Extensions (UDX).
  - A new mode, called Payment Card Industry (PCI) PIN Transaction Security (PTS) Hardware Security Module (HSM), shortened to PCI-HSM, is available exclusively for Crypto Express6S in CCA mode. PCI-HSM mode simplifies compliance with PCI requirements for hardware security modules.

- ▶ The Secure IBM Enterprise PKCS #11 (EP11) coprocessor implements an industry-standardized set of services that adheres to the PKCS #11 specification v2.20 and more recent amendments. It was designed for extended FIPS and Common Criteria evaluations to meet industry requirements.

This cryptographic coprocessor mode introduced the PKCS #11 secure key function.

**TKE feature:** The Trusted Key Entry (TKE) Workstation feature is required for supporting the administration of the Crypto Express6S when configured as an Enterprise PKCS #11 coprocessor or managing the new CCA mode PCI-HSM.

When the Crypto Express6S PCI Express adapter is configured as a secure IBM CCA co-processor, it still provides accelerator functions. However, up to three times better performance for those functions can be achieved if the Crypto Express6S PCI Express adapter is configured as an accelerator.

CCA enhancements include the ability to use triple-length (192-bit) Triple-DES (TDES) keys for operations, such as data encryption, PIN processing, and key wrapping to strengthen security. CCA also extended support for the cryptographic requirements of the German Banking Industry Committee Deutsche Kreditwirtschaft (DK).

Several features that support the use of the AES algorithm in banking applications also were added to CCA. These features include AES-related key management features and the AES ISO Format 4 (ISO-4) PIN blocks as defined in the ISO 9564-1 standard. PIN block translation is supported as well as usage of AES PIN blocks in other CCA callable services. IBM continues to add enhancements as AES finance industry standards are released.

### 3.6.3 Crypto Express5S (carry forward only)

The Crypto Express5S has one PCIe adapter per feature. For availability reasons, a minimum of two features is required. Up to 16 Crypto Express5S features are supported. The Crypto Express5S feature occupies one I/O slot in a PCIe I/O drawer.

Each adapter can be configured as a Secure IBM CCA coprocessor, a Secure IBM Enterprise PKCS #11 (EP11) coprocessor, or as an accelerator.

Crypto Express5S provides domain support for up to 85 logical partitions on IBM z13 and 40 logical partitions on z13s.

The Crypto Express5S feature supports all the functions of the Crypto Express6S, except the PCI-HSM standard.

### 3.6.4 Web deliverables

For more information about z/OS downloads, see the [z/OS website](#).

## 3.7 Coupling and clustering

Coupling connectivity for Parallel Sysplex on z14 use Coupling Express Long Reach (CE LR), Integrated Coupling Adapter Short Reach (ICA SR), and InfiniBand (IFB) technology. The ICA SR and HCA3-O SR are designed to support distances up to 150 m. The CE LR and HCA3-O LR fanout supports longer distances between systems.



CE LR, ICA SR, and InfiniBand technologies allow all of the z/OS-to-CF communication, CF-to-CF traffic, or Server Time Protocol (STP)<sup>5</sup> through high-speed fiber optic connections at short (up to 150 m) or long (up to 10 km, or 6.21 miles, unrepeated) distances.

See the [Coupling Facility Configuration Options](#) white paper for a more specific explanation regarding the coupling links technologies.

**Note:** The z14 will be the last Z platform to support InfiniBand coupling connectivity (SOD: Hardware Announcement 117-031).

### 3.7.1 Coupling Express Long Reach

The CE LR, first introduced on the z14 platform but also made available on IBM z13 and IBM z13s®, is a two-port PCIe native adapter that is used for long-distance coupling connectivity. CE LR uses a new coupling channel type: CL5. The CE LR feature uses PCIe Gen3 technology and is hosted in a PCIe I/O drawer.

The feature supports communication at unrepeated distances up to 10 km (6.2 miles) using 9 µm single-mode fiber optic cables and repeated distances up to 100 km (62 miles) using IBM Z qualified DWDM vendor equipment. It supports up to 4 CHPIDs per port and 8 or 32 subchannels (devices) per CHPID. The coupling links can be defined as shared between images within a CSS or spanned across multiple CSSs in a Z system.

### 3.7.2 Integrated Coupling Adapter: Short Reach

ICA SR, first introduced on the z13 platform, is a two-port fanout used for short distance coupling connectivity and uses the coupling channel type CS5. The ICA uses PCIe Gen3 technology, with x16 lanes that are bifurcated into x8 lanes for coupling.

The ICA SR supports cable length of up to 150 m and supports a link data rate of 8 GBps. It also supports up to four CHPIDs per port and 8 subchannels (devices) per CHPID. The coupling links can be defined as shared between images within a CSS. They can also be spanned across multiple CSSs in a Z system.

### 3.7.3 Host Channel Adapter3: Optical Long Reach

HCA3-O LR is a fanout card, based on InfiniBand protocol, that supports 1x InfiniBand (1x IFB). The HCA3-O LR fanout for 1x InfiniBand (1x IFB) provides four ports and optional additional subchannels for extended-distance solutions.

The HCA3-O LR 1x InfiniBand supports up to 16 CHPIDs. The CHPID type is CIB and up to 7 or 32 subchannels (devices) are supported.

InfiniBand (HCA3-O LR) coupling links support unrepeated distances up to 10 km (6.2 miles) using 9 µm single mode fiber optic cables and repeated distances up to 100 km (62 miles) using IBM Z qualified DWDM equipment. Connectivity to HCA2-O LR on older Z platforms is supported.

### 3.7.4 Host Channel Adapter3: Optical

HCA3-O is a fanout card, based on InfiniBand protocol, that supports 12x InfiniBand (12x IFB). The HCA3-O fanout for 12x InfiniBand (12x IFB) provides two ports and optional additional subchannels.

<sup>5</sup> All coupling links can be used to carry STP timekeeping information.

The 12x InfiniBand coupling links support double data rate (DDR) at 6 GBps for a z14 to z14 or other supported Z platforms.

InfiniBand (HCA3-O) coupling links (12x IFB) support distances up to 150 meters (492 feet) by using industry standard OM3 50 µm fiber optic cables. An HCA3-O to HCA2-O connection is supported.

### 3.7.5 Internal coupling

Internal coupling (IC) links are used for internal communication between LPARs on the same system running coupling facilities (CF) and z/OS images. The connection is emulated in Licensed Internal Code (LIC) and provides for fast and secure memory-to-memory communications between LPARs within a single system. No physical cabling is required.

### 3.7.6 Coupling Facility Control Code Level

Various levels (such as 22 and 23) of Coupling Facility Control Code (CFCC) are available for the z14. For more information, see [IBM Knowledge Center](#).

CF structure size changes can be expected when moving from one CFCC level to another. Review the CF LPAR size by using the following tools:

- ▶ The [CFSizer tool](#) is a web-based and is useful when a workload is changed or introduced
- ▶ The [Sizer Utility](#), which is an authorized z/OS program download, is useful when upgrading a CF

## 3.8 Virtual Flash Memory

IBM Virtual Flash Memory (VFM) is the replacement for the Flash Express features that were available on the z13 and zEC12. VFM can be ordered in 1.5 TB increments up to 6 TB in total.

VFM is designed to help improve availability and handling of paging workload spikes when running z/OS V2.1, V2.2, or V2.3. With this support, z/OS is designed to help improve system availability and responsiveness by using VFM across transitional workload events such as market openings, and diagnostic data collection. z/OS is also designed to help improve processor performance by supporting middleware exploitation of pageable large (1 MB) pages.

VFM can also be used in coupling facility images to provide extended capacity and availability for workloads that use WebSphere MQ Shared Queues structures. Using VFM can help availability by reducing latency from paging delays that can occur at the start of the workday or during other transitional periods. It is also designed to eliminate delays that can occur when collecting diagnostic data during failures.

Therefore, VFM can help meet most demanding service level agreements and compete more effectively. VFM is easy to configure and provides rapid time to value.

No application changes are required to migrate from IBM Flash Express to VFM.

## 3.9 Server Time Protocol

Each system must have an accurate time source to maintain a time-of-day value. Logical partitions use their system's time. When system images participate in a Sysplex, coordinating the time across all system images in the sysplex is critical to its operation.

The z14 supports the Server Time Protocol (STP) and can participate in a STP-only Coordinated Timing Network (CTN). A CTN is a collection of Z platforms that are time-synchronized to a time value called Coordinated Server Time (CST). Each CPC to be configured in a CTN must be STP-enabled. STP is intended for CPCs that must be time-synchronized.

STP is a message-based protocol in which timekeeping information is passed over coupling links between servers. The timekeeping information is transmitted over externally defined coupling links. The STP feature is the supported method for maintaining time synchronization between the z14 and coupling facilities (CF) in sysplex environments.

STP is implemented in LIC as a system-wide facility of the z14 and other Z platforms. STP presents a single view of time to PR/SM and provides the capability for multiple CPCs to maintain time synchronization with each other. The z14 is enabled for STP by installing the STP feature code. Extra configuration is required for a z14 to become a member of a CTN.

For high availability purposes, non-disruptive capability was implemented in the z14 firmware that allows two CTNs to be merged into one, or to split one CTN into two, dynamically.

STP supports a multi-site timing network of up to 100 km (62 miles) over fiber optic cabling, without requiring an intermediate site. This protocol allows a Parallel Sysplex to span these distances and reduces the cross-site connectivity that is required for a multi-site Parallel Sysplex.

### **Network Time Protocol client support**

The use of Network Time Protocol (NTP) servers as an External Time Source (ETS) usually fulfills a requirement for a time source or common time reference across heterogeneous platforms and for providing a higher time accuracy.

NTP client support is available in the Support Element (SE) code of the z14. The code interfaces with the NTP servers. This interaction allows an NTP server to become the single-time source for z14 and for other servers that have NTP clients.

### ***Pulse per second support***

Two oscillator cards (OSCs), included as a standard feature of the z14 provide a dual-path interface for the pulse per second (PPS) signal. The cards contain a BNC connector for PPS attachment at the rear side of Frame A of the Z platform. The redundant design allows continuous operation during the failure of one card, and concurrent card maintenance.

STP tracks the highly stable accurate PPS signal from the NTP server. PPS maintains accuracy of 10  $\mu$ s as measured at the PPS input of the z14.

If STP uses an NTP server without PPS, a time accuracy of 100 ms to the ETS is maintained. A cable connection from the PPS port to the PPS output of an NTP server is required when the z14 is configured for using NTP with PPS as the ETS for time synchronization.

For more information about STP, see the following IBM Redbooks publications:

- ▶ [Server Time Protocol Planning Guide, SG24-7280](#)
- ▶ [Server Time Protocol Implementation Guide, SG24-7281](#)
- ▶ [Server Time Protocol Recovery Guide, SG24-7380](#)

## 3.10 Hardware Management Console and Support Element

The HMC and SE are appliances that provide hardware management for IBM Z platforms. Hardware platform management covers a complex set of configuration, operation, monitoring, service management tasks, and other services that are essential to the operations of the Z platform.

With z14 ZR1, the HMC can be a stand-alone desktop computer or an optional 1U rack-mounted computer.

**Important:** IBM z14 ZR1 is planned to be the last platform that will allow HMC support across the previous four generations of Z platforms (N - N-4). Future HMC releases are intended to be tested for support of the previous two generations (N - N-2).

The z14 ZR1 is supplied with a pair of integrated 1U SEs. The primary SE is always active; the other SE is an alternative. Power for the SEs is supplied by the rack PDUs. Each support Element features dual PSU units, 1+1 redundant.

The SEs and HMCs are closed systems, and no other applications can be installed on them.

The SEs are connected to Ethernet switches for network connectivity with the CPC and the HMCs. An HMC communicates with one or more Z platforms, as shown in Figure 3-1.

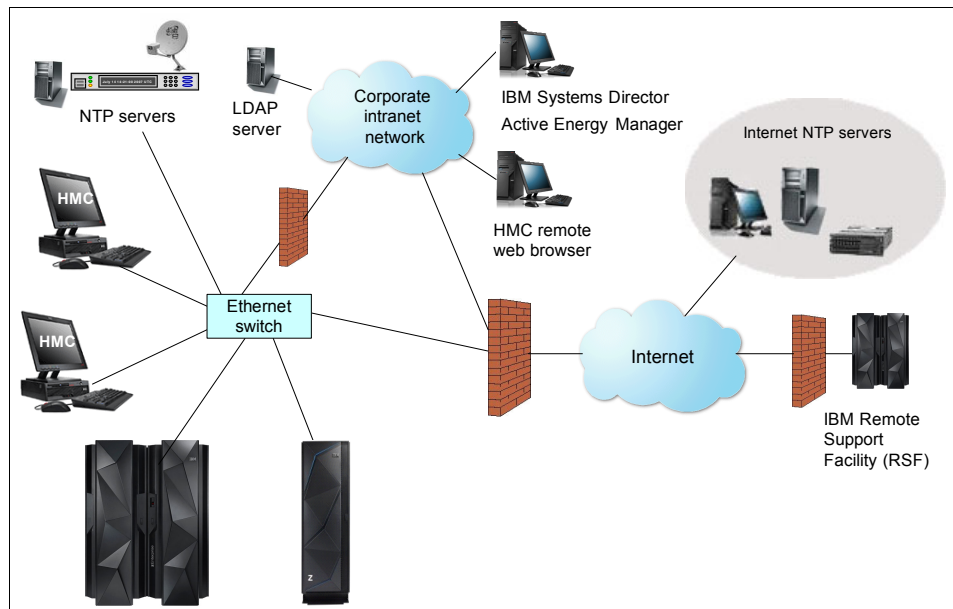

Figure 3-1 HMC and SE connectivity

When tasks are performed on the HMC, the commands are sent to one or more SEs, which then issue commands to their CPCs.

The HMC Remote Support Facility (RSF) provides communication with the IBM support network for hardware problem reporting and service.

**Note:** An RSF connection through a modem is *not* supported on the z14 HMC. An internet connection to IBM is required to enable hardware problem reporting and service.

HMC/SE Version 2.14.0 or later is required for the z14.

For more information about the key capabilities and enhancements of the HMC, see *IBM z14 Technical Guide*, SG24-8451.





## Strengths of the z14 platform

Computer systems that stay relevant for more than 50 years demonstrate a forward-looking system architecture. IBM Z platforms are a prime example of this with the IBM z/Architecture<sup>1</sup>.

Advanced capabilities are introduced with each new Z platform that cause it to move ahead of its predecessor platforms in terms of efficiency, flexibility, security, reliability, and much more. Whenever new capabilities are implemented, the z/Architecture is extended rather than replaced, which helps sustain the compatibility, integrity, and longevity of the Z platform. Thus, *protection* and *backward compatibility* of existing workloads and solutions are key for the new capabilities introduced in the z/Architecture.

To handle new and different workloads, the scope of software and application options must be accommodated by the operating system. Also, the hardware and firmware components of the system must provide a viable option to integrate functionality into the architecture's capabilities. The Z platforms and operating systems always conform to the z/Architecture to ensure support of current and future workloads and solutions.

This chapter highlights several z14 capabilities and strengths, and explains how they can be of value for businesses and organizations. Throughout the chapter, reference is made to the following IBM Redbooks publications:

- ▶ *IBM z14 Technical Guide*, SG24-8451
- ▶ *IBM Z Connectivity Handbook*, SG24-5444

This chapter includes the following topics:

- ▶ 4.1, “Technology improvements” on page 58
- ▶ 4.2, “Virtualization” on page 62
- ▶ 4.3, “Capacity and performance” on page 71
- ▶ 4.4, “Reliability, availability, and serviceability” on page 76
- ▶ 4.5, “High availability with Parallel Sysplex” on page 78
- ▶ 4.6, “Pervasive encryption” on page 82

---

<sup>1</sup> IBM z/Architecture is the conceptual structure of the Z platform that determines its basic behavior. The architecture was first introduced as System/360 in 1964.

## 4.1 Technology improvements

The z14 includes technology improvements that are intended to make systems integration more scalable, flexible, manageable, and secure.

The following sections provide details about the technology improvements for the z14.

### 4.1.1 Processor design highlights

The z/Architecture that underlies the z14 offers a rich complex instruction set computer (CISC) that supports multiple arithmetic formats. Compared to its predecessor system, the z14 processor design includes the following improvements and architectural extensions:

- ▶ Better performance and throughput:
  - Faster processor units (5.2 GHz compared to 5.0 GHz in the z13)
  - More capacity (up to 170 characterizable processor units versus 141 on the z13)
  - Larger cache (and shorter path to cache) means faster uniprocessor performance

Innovative core-cache design (L1 and L2), processor chip-cache design (L3), and cluster design (L4), with focus on keeping more data closer to the processor, increasing the cache sizes, and decreasing the latency to access the next levels of cache
- ▶ Reoptimized pipeline depth for power and performance:
  - Improved instruction delivery
  - Faster branch wakeup
  - Reduced execution latency
  - Improved Operand Store Compare (OSC) avoidance on Dispatch Store Table (DST)
  - Optimized second-generation SMT2
- ▶ New translation design
  - Four concurrent translations (from one in the z13)
  - Reduced latency
  - Lookup integrated into L2 access pipe
  - Translation Lookaside Buffer enhancements:
    - 2x CRSTE growth
    - 1.5x PTE growth
    - New 64 entry 2 GB
- ▶ Better Branch Prediction
  - 33% Larger (Branch Target Buffer (BTB) for BTB1 & BTB2
  - New Perceptron Predictor
  - New Simple Call Return Stack
- ▶ Dedicated co-processor for each processor unit (PU):
  - The Central Processor Assist for Cryptographic Function (CPACF) in the z14 has been optimized to provide up to six times faster encryption functions than the z13. CPACF on z14 supports new SHA-3 standard, True Random Number Generator, and four times Advanced Encryption Standard (AES) speedup.
  - On-chip Compression CMPSC on z14 offers up to two times expansion speedup and supports Entropy Encoding (Huffman Coding) and Order Preserving Compression for index/sort-file compression.



## Transactional Execution Facility

The Transactional Execution Facility, which is known in the industry as *hardware transactional memory*, allows instructions to be issued atomically. So either *all results* of the instructions in the group are committed or *no results* are committed, in a truly transactional manner. The execution is optimistic.

The instructions are issued, but previous state values are saved in transactional memory. If the transaction succeeds, the saved values are discarded. If it fails, they are used to restore the original values. Software can test the success of execution and rederive the code, if needed, using the same or a different path.

The Transactional Execution Facility provides several instructions, including instructions to declare the start and end of a transaction and to cancel the transaction. This capability can provide performance benefits and scalability to workloads by helping to avoid most of the locks on data. This ability is especially important for heavily threaded applications, such as Java.

## Guarded Storage Facility

Also known as less-pausing garbage collection, Guarded Storage Facility is a new architecture that was introduced with z14 to enable enterprise scale Java applications to run without periodic pause for garbage collection on larger heaps. This facility improves Java performance by reducing program pauses during Java Garbage Collection.

## Instruction Execution Protection

Instruction Execution Protection (IEP) is a new hardware function that was introduced with z14 that enables software like Language Environment to mark certain memory regions (for example, a heap or stack) as non-executable to improve the security of programs running on Z against stack-overflow or similar attacks.

## Simultaneous multithreading

Simultaneous multithreading (SMT) is built into the z14 IFLs, zIIPs, and SAPs allowing more than one thread to simultaneously run in the same core, sharing all of its resources. This function improves utilization of the cores and increases processing capacity.

When a program accesses a memory location that is not in the cache, it is called a *cache miss*. Because the processor must then wait for the data to be fetched before it can continue to run, cache misses affect the performance and capacity of the core to run instructions. By using SMT, when one thread in the core is waiting (such as for data to be fetched from the next cache levels or from main memory), the second thread in the core can use the shared resources rather than remain idle.

Adjusted with the growth in the core cache and TLB2, second generation SMT on z14 improves thread balancing, supports multiple outstanding translations, optimizes hang avoidance mechanisms, and delivers improved virtualization performance to benefit Linux. z14 provides economies of scale with next generation multithreading (SMT) for Linux and zIIP-eligible workloads while adding new support for the I/O System Assist Processor (SAP).

## Hardware decimal floating point function

The hardware decimal floating point (HDFP) function is designed to speed up calculations and provide the precision demanded by financial institutions and others. The HDFP fully implements the IEEE 754r standard.

## Vector Packed Decimal Facility

Vector Packed Decimal Facility allows packed decimal operations to be performed in registers rather than memory using new fast mathematical computations. Compilers, such as Enterprise COBOL for z/OS, V6.2, Enterprise PL/I for z/OS, V5.2, z/OS V2.3 XL C/C++, the COBOL optimizer, Automatic Binary Optimizer for z/OS, V1.3, and Java, are optimized on z14.

## Single instruction, multiple data

The z14 includes a set of instructions called single instruction, multiple data (SIMD) that can improve the performance of complex mathematical models and analytics workloads. This improvement is accomplished through vector processing and complex instructions that are able to process a large volume of data with a single instruction.

SIMD is designed for parallel computing and can accelerate code that contains integer, string, character, and floating point data types. This system enables better consolidation of analytics workloads and business transactions on the Z platform.

## Runtime Instrumentation Facility

The Runtime Instrumentation Facility provides managed run times and just-in-time compilers with enhanced feedback about application behavior. This capability allows dynamic optimization of code generation as it is being run.

## Central Processor Assist for Cryptographic Function

CPACF is a high performance, low latency co-processor that can use DES, TDES, AES-128, AES-256, SHA-1, SHA-2, and SHA-3 ciphers to perform symmetric key encryption and calculate message digests in hardware. It is well suited for encrypting large amounts of data in real time because of its proximity to the processor unit. For the z14, CPACF encryption modes have been accelerated 4 to 6 times over the z13.

## Compression Coprocessor

Compression Coprocessor (CMPSC) is a high-performance coprocessor that uses compression algorithms to help reduce disk space and memory usage. Each processor unit has a dedicated CMPSC that connects to the main cache-structure for better throughput of the compression dictionaries.

In the z14, the compression and expansion performance has been improved with fewer CPU cycles. In addition, the compression ratio with Huffman coding garners more disk space and memory usage savings even where compression is already in use. Also, order-preserving compression for search trees and sort files can be used for large parts of data and DB2 indexes that were not practical to compress previously.

## 4.1.2 Memory

Memory is significantly greater in the new Z models. The z14 can have up to 32 TB of usable memory installed, compared with the 10 TB maximum on the z13.

In addition, on the z14, the hardware system area (HSA) is expanded to 192 GB (from 96 GB on z13). The HSA has a fixed size and is not included in the memory that the client orders.

**z/Architecture addressing modes:** The z/Architecture simultaneously supports 24-bit, 31-bit, and 64-bit addressing modes. This feature provides compatibility with earlier versions and, with that, investment protection.

The maximum memory size per logical partition (LPAR) has changed as well. For example, on the z14, up to 16 TB of memory can now be defined to an LPAR in the image profile. Each operating system can allocate main storage up to the maximum memory amount supported.

### Dynamic memory relocation

LPAR memory assignment is done at the time of image activation. On z14, the memory allocation algorithm has evolved from previous systems. The goal of IBM Processor Resource/Systems Manager (PR/SM) memory and processor unit resource allocation is to assign all LPAR resources on a single CPC drawer, if possible. The resources (memory, and processor units) are assigned to the LPARs when they are activated. Later, when all LPARs are activated, PR/SM can dynamically move memory between CPC drawers to benefit performance, without affecting the operating system.

### Plan-ahead memory

If you anticipate someday increasing the installed memory, the initial system order can contain both starting and potential additional memory sizes. The additional memory is referred to as *plan-ahead memory*, which has a specific memory pricing model to support it.

The starting memory size is activated when the system is installed, and the rest remains inactive. When more physical memory is required, it is fulfilled by activating the appropriate number of plan-ahead memory features. This activation is concurrent and might be nondisruptive to applications depending on the level of operating system support. z/OS and z/VM both support this function.

**Note:** Do not confuse *plan-ahead* and *flexible memory* support:

- ▶ Plan-ahead memory is for a permanent increase of installed memory.
- ▶ Flexible memory (described in the next subsection) provides a temporary replacement of a part of memory that becomes unavailable.

### Flexible memory

Flexible memory provides the additional physical memory needed to support activation base memory and HSA on a z14 with multiple CPC drawers that has one CPC drawer out of service.

On z14, the additional resources that are required for flexible memory configurations are provided through the purchase of planned memory features and memory entitlement. Flexible memory configurations are available only on z14 models M02, M03, M04, and M05, and range 320 GB - 2.5 TB, depending on the model.

### IBM Virtual Flash Memory

New with z14, the Virtual Flash Memory (VFM) feature is offered from the main memory capacity in 1.5 TB units, and replaces the Flash Express adapters that were available on the zEC12 and z13. VFM provides much simpler management and better performance by eliminating the I/O of the adapters located in the PCIe drawers. VFM does not require any application changes when moving from IBM Flash Express.

VFM can help improve availability and handling of paging workload spikes when running z/OS. VFM can also be used in coupling facility images to provide extended capacity and availability for workloads that use WebSphere MQ Shared Queues structures.

VFM can improve availability by reducing latency from paging delays that can occur during peak workload periods. It is also designed to help eliminate delays that can occur when collecting diagnostic data during failures.

## Large page support

The size of pages and page frames has remained at 4 KB for a long time. IBM Z platforms can have large pages of 1 MB, in addition to supporting pages of 4 KB. This capability relates primarily to large main storage usage. Both page frame sizes can be used simultaneously.

Large pages enable the translation lookaside buffer (TLB) to better represent the working set and suffer fewer misses by allowing a single TLB entry to cover more address translations. Large pages are better represented in the TLB and are expected to perform better.

**Note:** Large pages can benefit long-running applications that are memory-access intensive and might not be the best fit for general use. Short-lived processes with small working sets see little to no improvement. Base the decision to use large pages on measurements of memory usage and page translation overhead for specific workloads.

## Support for 2 GB large pages

z14 uses the same 2 GB page frames that were first introduced with zEC12 to increase efficiency for DB2 buffer pools, Java heaps, and other large structures. Using 2 GB pages increases TLB coverage without proportional growth in the size of the TLB:

- ▶ A 2 GB memory page is 2048 times larger than a 1 MB large page, and 524,288 times larger than an ordinary 4 KB base page.
- ▶ A 2 GB page allows a single TLB entry to fulfill many more address translations than either a large page or ordinary base page.
- ▶ A 2 GB page provides users with much better TLB coverage, which improves performance:
  - Decreases the number of TLB misses that an application incurs
  - Spends less time converting virtual addresses into physical addresses
  - Uses less real storage to maintain DAT structures

## 4.2 Virtualization

Virtualization is a key strength of Z platforms. It is embedded in the architecture and built into the hardware, firmware, and operating systems. For decades, Z platforms have been designed based on the concept of partitioning resources (such as CPU, memory, storage, and network resources) so that each set of features can be used independently with its own operating environment.

The z14 is highly virtualized, with the goal of maximizing utilization of computing resources, while lowering the total number of resources and cost needed to run critical workloads and solutions.

Virtualization requires a *hypervisor*, which is the control code that manages resources that are required for multiple independent operating system images. Hypervisors can be implemented as software or hardware, and the z14 has both. The hardware hypervisor is IBM PR/SM. PR/SM is implemented in firmware as part of the base system, fully virtualizes the system resources, and runs without any additional software. A software hypervisor is implemented with the z/VM operating system and KVM for IBM Z<sup>2</sup>, both of which use PR/SM functions.

---

<sup>2</sup> IBM is changing how KVM for IBM Z is delivered. KVM hypervisor will now be offered through our Linux distribution partners.

The hypervisors are designed to enable simultaneous execution of multiple operating systems, providing operating systems with virtual resources.

Multiple hypervisors can exist on the same Z platform (see Figure 4-1).

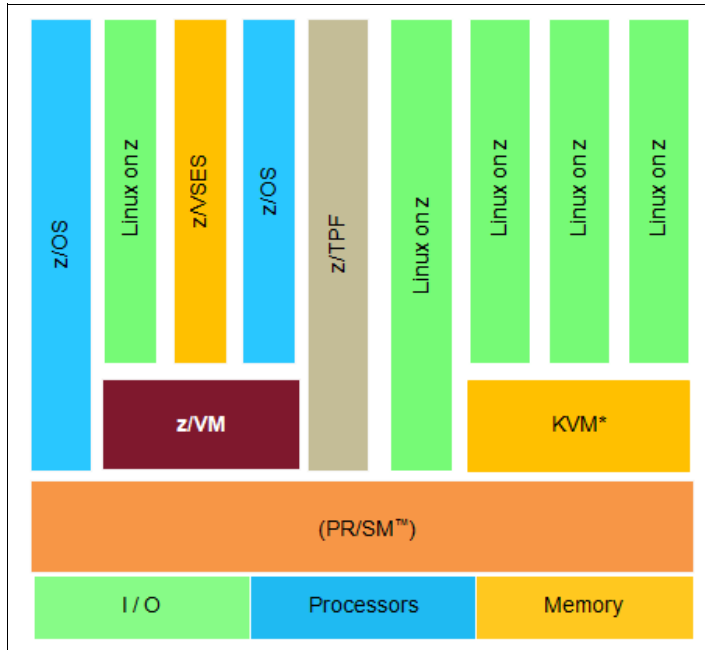

Figure 4-1 Support for coexistence of different hypervisors

The various virtualization options in Z platforms allow you to build flexible virtualized environments to take advantage of open source software or upgrade to new cloud service offerings, such as infrastructure as a service (IaaS) and platform as a service (PaaS)

## PR/SM

Unique to Z platforms, PR/SM is a Type-1 hypervisor that runs directly on bare metal, allowing you to create multiple LPARs on the same physical server. PR/SM is a highly stable, proven, and secure, firmware-encapsulated virtualization technology that allows multiple operating systems to run on the same physical platform. Each operating system runs in its own logical partition.

PR/SM logically partitions the platform across the various LPARs to share resources, such as processor units, memory, and I/O (for networks and storage), allowing for a high degree of virtualization.

## Dynamic Partition Manager

Dynamic Partition Manager (DPM) is a management infrastructure mode in the z14. It is intended to simplify virtualization management and is easy to use, especially for users who are less experienced with Z. It does not require you to learn complex syntax or command structures.

Software hypervisors, operating systems, secure service containers, and software appliances that can exist on the Z platform in DPM mode are shown in Figure 4-2 on page 64.

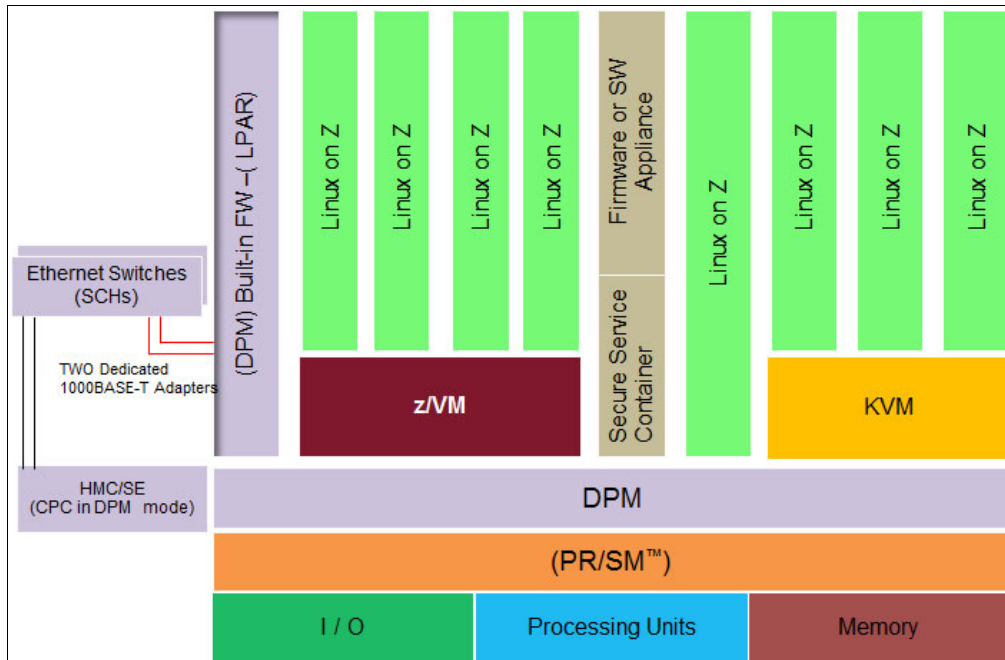

Figure 4-2 Support for coexistence of different software hypervisors (in DPM mode)

DPM provides simplified hardware and virtual infrastructure management, including partition lifecycle and integrated dynamic I/O and PCIe functions management for Linux that is running in an LPAR, under the KVM hypervisor, and under z/VM. By using DPM, an environment can be created, provisioned, and modified without disrupting running workloads. It also can be monitored for troubleshooting.

DPM provides the following capabilities through the Hardware Management Console (HMC):

- ▶ Create and provision an environment, including new partitions, assignment of processors and memory, and configuration of I/O adapters.
- ▶ Manage the environment, including the ability to modify system resources without disrupting workloads.
- ▶ Monitor and troubleshoot the environment to identify system events that might lead to degradation.

Enhancements to DPM on z14 simplify the installation of the Linux operating system, support more hardware features, and enable base cloud provisioning through Openstack, including the following enhancements:

- ▶ Support for auto-configuration of devices to simplify Linux Operating System Installation, where Linux distribution installers use functions
- ▶ Secure FTP through HMC for starting and installing an Operating system by using FTP
- ▶ Support for OSA-Express7S, OSA-Express6S, FICON Express 16S+, Crypto Express6S, 25GbE RoCE Express and 10GbE RoCE Express2 features

**Configuration note:** The z14 can be configured in DPM mode or in PR/SM mode, but cannot be configured in both modes at the same time. DPM supports FCP and ECKD™ storage.

## **z/VM**

z/VM is a Type-2 hypervisor that allows sharing the mainframe's physical resources, such as disk, memory, network adapters, and CPUs (called *CPs* and *IFLs*). These resources are managed by the z/VM hypervisor, which typically runs on an LPAR and other virtual machines (VMs) that run on top of the hypervisor. Typically, the z/VM hypervisor is used to run Linux virtual servers, but other operating systems (such as z/OS) can also run on z/VM. z/VM is a proven and well established virtualization platform. It provides industry-leading capabilities to efficiently scale both horizontally and vertically.

## **KVM hypervisor for IBM Z**

The KVM hypervisor for IBM Z is an open virtualization solution that provides simple, cost-effective server virtualization for Linux workloads running on the Z platform. It is a Type-2 hypervisor that delivers server virtualization based on open source KVM Linux technology.

The KVM hypervisor for IBM Z enables you to share real CPUs (called IFLs), memory, and I/O resources through platform virtualization. It can coexist with z/VM virtualization environments, Linux on IBM Z, z/OS, z/VSE, and z/TPF. The KVM hypervisor for IBM Z is optimized for scalability, performance, security, and resiliency, and provides standard Linux and KVM interfaces for simplified operational control.

The KVM hypervisor for Z for the z14 is offered with the following Linux distributions:

- ▶ Red Hat Enterprise Server RHEL 7.3 with service (or higher)
- ▶ SUSE Linux Enterprise Server 12 SP2 with service (or higher)
- ▶ Canonical Ubuntu 16.04 LTS with service (or higher)

### **4.2.1 Hardware virtualization**

PR/SM was first implemented in the mainframe in the late 1980s. It allows you to define and manage LPARs. PR/SM virtualizes processor units, memory, and I/O features. Certain features are purely virtualized implementations.

PR/SM technology on the z14 received Common Criteria EAL5+ security certification. PR/SM is always active on the system and is enhanced to provide better performance and platform management benefits.

The LPAR definition includes a number of logical processor units (LPUs), memory, and I/O devices. IBM z/Architecture is designed to meet requirements with low overhead and also has achieved Common Criteria EAL5+ (the highest security certification in the industry) with a Specific Target of Evaluation (Logical Partitions). This design has been proven in many client installations over several decades.

Up to 85 LPARs can be defined on z14 and hundreds or even thousands of virtual servers can be run under z/VM or KVM for IBM Z.

#### **Logical processors**

Logical processors are defined and managed by PR/SM, and are perceived by the operating systems as real processors. These processors can be characterized as follows:

- ▶ Central processors (CP) are standard processors for use with any supported operating system and user applications.

- ▶ IBM System z® Integrated Information Processor (zIIP) is used under z/OS for designated workloads. These workloads include but not limited to IBM Java virtual machine (JVM), various XML System Services, IPSec offload, certain parts of IBM DB2 DRDA, DFSMS System Data Mover for z/OS Global Mirror, IBM HiperSockets for large messages, and the IBM GBS Scalable Architecture for Financial Reporting (SAFR) enterprise business intelligence reporting.
- ▶ Integrated Facility for Linux (IFL) is exclusively used with Linux on z Systems, and for running the z/VM and KVM hypervisors in support of Linux virtual machines (also called *guests*).
- ▶ Internal Coupling Facility (ICF) is used for z/OS clustering. ICF is dedicated to this function and exclusively run the Coupling Facility Control Code (CFCC).

In addition, the following pre-characterized processors are part of the base system configuration and are always present:

- ▶ System assist processors (SAP) that run I/O operations
- ▶ Integrated firmware processors (IFP) for native PCIe features

These processors provide support for all LPARs but are never part of an LPAR configuration.

PR/SM accepts requests for work on logical processors by dispatching logical processors on physical processors. Physical processors can be shared across LPARs, but can also be dedicated to an LPAR. However, the logical processors of an LPAR must be either all shared or all dedicated.

The sum of logical processors defined in all active LPARs in a Z system might be higher than the number of physical processor units. The maximum number of LPUs that can be defined in a single LPAR cannot exceed the total number physical processor units that are available in the CPC. To achieve optimal ITR performance in sharing LPUs, the total number of online LPUs should be kept to a minimum, which reduces software and hardware overhead.

PR/SM ensures that, when switching a physical processor from one logical processor to another, the processor state is properly saved and restored, including all registers. Data isolation, integrity, and coherence inside the system are strictly enforced at all times.

Logical processors can be dynamically added to and removed from LPARs. Operating system support is required to take advantage of this capability. z/OS, z/VM, and z/VSE each can dynamically define and change the number and type of reserved processor units in an LPAR profile. No pre-planning is required.

The new resources are immediately available to the operating systems and, for z/VM, to its guest images. Linux on z Systems provides the Standby CPU activation/deactivation function.

## Memory

To ensure security and data integrity, memory cannot be concurrently shared by active LPARs. In fact, a strict isolation is maintained.

A logical partition can be defined with both an initial and a reserved amount of memory. At activation time, the initial amount is made available to the partition, and the reserved amount can later be added, partially or totally. Those two memory zones do not have to be contiguous in real memory, but the addressing area (for initial and reserved memory) is presented to the operating system that runs in the LPAR as contiguous.



Using the plan-ahead option, memory can be physically installed without being enabled. It can then be enabled when necessary. z/OS can take advantage of this support by nondisruptively acquiring and releasing memory from the reserved area. z/VM can acquire memory nondisruptively and quickly make it available to guests. z/VM virtualizes this support to its guests, which can also increase their memory nondisruptively. Releasing memory is still a disruptive operation.

LPAR memory is said to be virtualized in the sense that, within each LPAR, memory addresses are contiguous and start at address zero. LPAR memory addresses are different from the system's absolute memory addresses, which are contiguous and have a single address of zero. Do not confuse this capability with the operating system that virtualizes its LPAR memory, which is done through the creation and management of multiple address spaces.

The z/Architecture has a robust virtual storage architecture that allows LPAR by LPAR definition of an unlimited number of address spaces and the simultaneous use by each program of up to 1023 of those address spaces. Each address space can be up to 16 EB (1 exabyte =  $2^{60}$  bytes). Thus, the architecture has no real limits. Practical limits are determined by the available hardware resources, including disk storage for paging.

Isolation of the address spaces is strictly enforced by the Dynamic Address Translation hardware mechanism. A program's right to read or write in each page frame is validated by comparing the page key with the key of the program that is requesting access. This mechanism has been in use since the System/370. Memory keys were part of, and used by, the original System/360 systems.

Definition and management of the address spaces is under operating system control. Three addressing modes (24-bit, 31-bit, and 64-bit) are simultaneously supported, which provides compatibility with earlier versions and investment protection.

z14 supports 2 GB pages, in addition to 4 KB and 1 MB pages, and an extension to the z/Architecture called Enhanced Dynamic Address Translation-2 (EDAT-2).

Operating systems can allow sharing of address spaces, or parts of them, across multiple processes. For example, under z/VM, a single copy of the read-only part of a kernel can be shared by all virtual machines that use that operating system. Known as discontinuous shared segment (DCSS), this shared memory exploitation for many virtual machines can enable large savings of real memory and improvements in performance.

## **I/O virtualization**

The z14 supports six logical channel subsystems (LCSSs), each with 256 channels, for a total of 1536 channels. In addition to the dedicated use of channels and I/O devices by an LPAR, I/O virtualization allows concurrent sharing of channels. The z/Architecture also allows sharing the I/O devices that are accessed through these channels, by several active LPARs. This function is known as multiple image facility (MIF). The shared channels can belong to different channel subsystems, in which case they are known as *spanned channels*.

Data streams for the sharing LPARs are carried on the same physical path with total isolation and integrity. For each active LPAR that has the channel configured online, PR/SM establishes one logical channel path. For availability reasons, multiple logical channel paths should exist for critical devices (for instance, disks that contain vital data sets).

When more isolation is required, configuration rules allow restricting the access of each logical partition to particular channel paths and specific I/O devices on those channel paths.

Many installations use the parallel access volume (PAV) function, which allows accessing a device by several addresses (normally one base address and an average of three aliases). This feature increases the throughput of the device by using more device addresses. HyperPAV takes the technology a step further by allowing the I/O Supervisor (IOS) in z/OS (and the equivalent function in the Control Program of z/VM) to create PAV structures dynamically. The structures are created depending on the current I/O demand in the system, lowering the need for manually tuning the system for PAV use.

In large installations, the total number of device addresses can be high. Thus, the concept of *channel sets* is part of the z/Architecture.

### **Subchannel sets**

On the z14, up to four sets of approximately 64,000 device addresses are available. This availability allows the base addresses<sup>3</sup> to be defined on set 0 (IBM reserves 256 subchannels on set 0) and the aliases on set 1, set 2, and set 3. In total, 261,885 subchannel addresses are available per channel subsystem.

Subchannel sets are used by the *Metro Mirror* (also referred to as *synchronous Peer-to-Peer Remote Copy* (PPRC)) function by having the Metro Mirror primary devices defined in subchannel set 0. Secondary devices can be defined in subchannel sets 1, 2, and 3, providing more connectivity through subchannel set 0.

To reduce the complexity of managing large I/O configurations further, Z introduced extended address volumes (EAV). EAV provides large disk volumes. In addition to z/OS, both z/VM and Linux on z Systems support EAV.

By extending the disk volume size, potentially fewer volumes are required to hold the same amount of data, making systems and data management less complex. EAV is supported by the IBM DS8000 series. Check devices from other vendors for EAV compatibility.

The health checker function in z/OS has a health check in the I/O Supervisor that can help system administrators identify single points of failure in the I/O configuration.

The dynamic I/O configuration function is supported by z/OS and z/VM. It provides the capability of concurrently changing the currently active I/O configuration. Changes can be made to channel paths, control units, and devices. The existence of a fixed HSA area in the z14 greatly eases the planning requirements and enhances the flexibility and availability of these reconfigurations.

## **4.2.2 IBM Z based clouds**

Cloud computing is a paradigm for providing IT services. It capitalizes on the ability to rapidly and securely deliver standardized service offerings, while retaining the capacity for customizing the environment. Elasticity, which allows the system to deal with the ebbs and flows of demand dynamically, and using just-in-time provisioning is another requirement.

Virtualization is critical to the economic and financial viability of cloud service offerings, because it allows minimizing the over-provisioning of resources, and reusing them at the end of the virtual server lifecycle.

---

<sup>3</sup> Only z/OS base device must be in subchannel set 0. Linux on IBM Z supports base devices in the other subchannels sets.

Because of the extreme integration in the hardware, virtualization on z14 is highly efficient (the best in the industry) and encompasses computing and I/O resources, including the definition of *internal virtual networks* with *virtual switches*. These are all characteristics of *software-defined environments*.

These characteristics allow support on a single real server, dense sets of virtual servers and server networks with up to 100% sustained resource utilization, and the highest levels of isolation and security. Therefore, the cloud solution costs, whether hardware, software, or management, are minimized.

Cloud elasticity requirements are covered by the z14 granularity offerings, including capacity levels and capacity on demand. These and other technologic leadership characteristics that make the Z platforms the server golden standard.

In addition, managing a cloud environment requires tools that can take advantage of a pool of virtualized compute, storage, and network resources, and present them to the consumer as a service in a secure way. A cloud management system should also help with these tasks:

- ▶ Offering open cloud management and application programming interfaces (APIs)
- ▶ Improving the usage of the infrastructure
- ▶ Lowering administrative overhead and improving operations productivity
- ▶ Reducing management costs and improving responsiveness to changing business needs
- ▶ Automating resource allocation
- ▶ Providing a self-service interface
- ▶ Tracking and metering resource usage

A cloud management system must also support the management of virtualized IT resources to support different types of cloud service models and cloud deployment models. OpenStack (offered for z/VM and KVM for IBM Z) can satisfy a wide range of cloud management demands. It integrates various components to automate IT infrastructure service provisioning.

Figure 4-3 shows Z cloud architecture that provides an industrial-strength base for hybrid cloud and API economy.

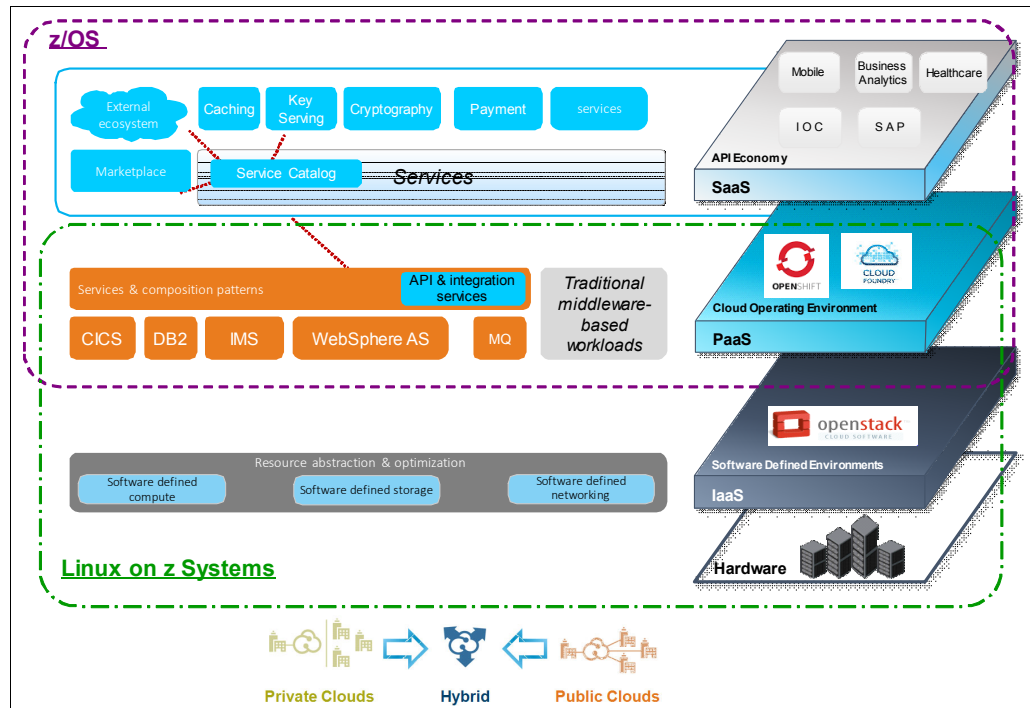

Figure 4-3 Z cloud architecture

### 4.2.3 Secure Service Container

The IBM Secure Service Container (SSC) provides the base infrastructure to create an IBM Z Appliance, which includes operating system, middleware, SDK and firmware support. With an SSC, deploying an appliance (that provides a function or a service) takes minutes instead of days, while providing simplified management and maintenance. When deployed in an SSC, the workload is protected from inadvertent access from an external attacker or even from a system administrator.

IBM Z Appliance is an integration of operating system, middleware, and various software components that work autonomously to provide core infrastructure services while focusing on consumability and security. The appliance is deployed in an SSC LPAR running in an IBM Z platform. The SSC LPAR in the Z platform provides support for:

- ▶ Encapsulated Operating Systems
- ▶ Remote APIs (RESTful) and web interfaces
- ▶ Embedded monitoring and self-healing
- ▶ Tamper-protection
- ▶ Protected IP
- ▶ Tested and qualified by IBM for a specific use case
- ▶ Can be delivered either as firmware, platform, or software

At the time of this writing, the following IBM Z Appliances were available to be deployed in a Secure Service Container:

- ▶ z/VSE Network Appliance
- ▶ IBM Z Advanced Workload Analysis Reporter (IBM zAware), now deployed as software and integrated with IBM Operations Analytics for IBM Z

## 4.3 Capacity and performance

The z14 offers significant increases in capacity and performance over its predecessor, the z13. Several elements contribute to this effect, including the larger number of processors, individual processor performance, memory caches, SMT and machine instructions, including the SIMD. Subcapacity settings continue to be offered.

**Note:** Capacity and performance ratios are based on measurements and projections using standard IBM benchmarks in a controlled environment. Actual throughput can vary depending on several factors, such as the job stream, the I/O and storage configurations, and the workload type.

### 4.3.1 Capacity settings

The z14 expands the offer on subcapacity settings. Finer granularity in capacity levels allows the growth of installed capacity to more closely follow the enterprise growth, for a smoother, pay-as-you-go investment profile. Many performance and monitoring tools are available on Z environments that are coupled with the flexibility of the capacity on-demand options (see 4.3.2, “Capacity on demand” on page 72). These features help to manage growth by making capacity available when needed.

#### **z14 capacity levels**

Regardless of the installed model, the z14 offers four distinct capacity levels for the first 33 CPs:

- ▶ One full capacity
- ▶ Three subcapacities

These processors deliver the scalability and granularity to meet the needs of medium-sized enterprises, while also satisfying the requirements of large enterprises that have large-scale, mission-critical transaction and data processing requirements.

A capacity level is a setting of each CP<sup>4</sup> to a subcapacity of the full CP capacity. The clock frequency of those processors remains unchanged. The capacity adjustment is achieved through other means.

Full capacity CPs are identified as CP7. On the z14, up to 170 CPs can be configured as CP7. The three subcapacity levels are identified by CP6, CP5, and CP4, and are displayed in hardware descriptions as feature codes on the CPs.

If more than 33 CPs are configured to the system, then all must be full capacity because all CPs must be at the same capacity level. Granular capacity adds 99 subcapacity settings to the 170 capacity settings that are available with full capacity CPs (CP7). The 269 distinct capacity settings in the system provide for a range of over 1:572 in processing power.

A processor that is characterized as anything other than a CP, such as a zIIP, an IFL, or an ICF, is always set at full capacity. There is, correspondingly, a separate pricing model for non-CPs regarding purchase and maintenance prices, and various offerings for software licensing.

---

<sup>4</sup> The CP is the standard processor for use with any supported operating system, but is requested to run z/OS.

On z14, the CP subcapacity levels are a fraction of full capacity, as follows:

- ▶ Model 7xx = 100%
- ▶ Model 6xx = 59%
- ▶ Model 5xx = 41%
- ▶ Model 4xx = 14%

For administrative purposes, systems that have only ICFs or IFLs are now given a capacity setting of 400. For either of these systems, having up to 170 ICFs or IFLs, which always run at full capacity, is possible.

Figure 4-4 provides more information about z14 full capacity and subcapacity offerings.

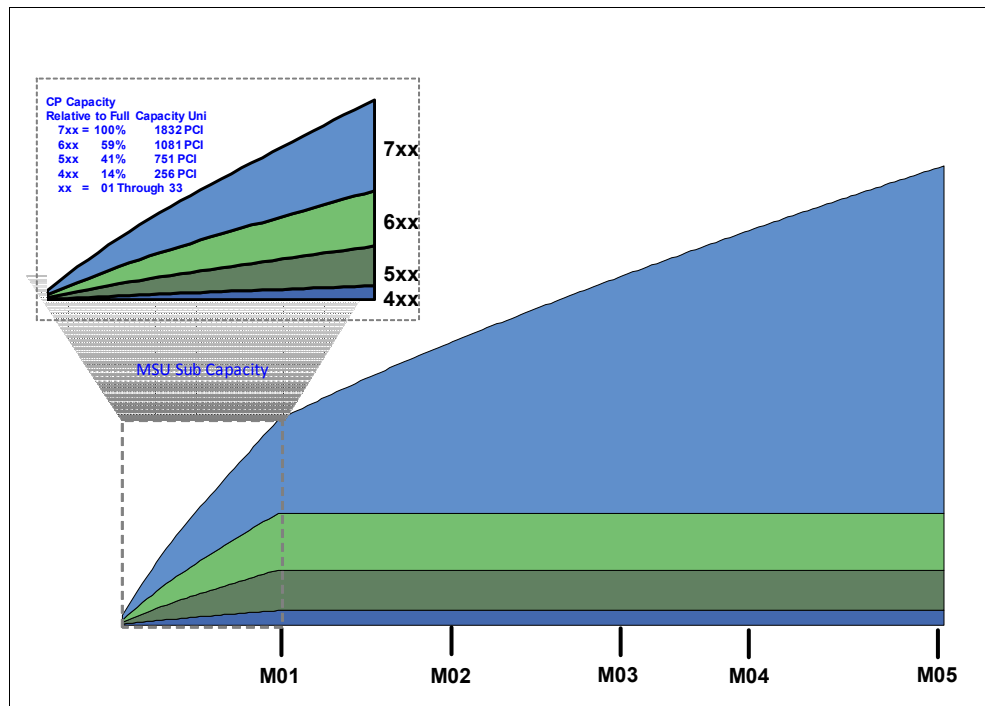

Figure 4-4 z14 full and subcapacity CP offerings

To help size a Z platform to fit client requirements, IBM provides a no-cost tool that reflects the latest IBM LSPR measurements, called the IBM Processor Capacity Reference for z (zPCR). You can download the tool [here](#).

For more information about LSPR measurements, see 4.3.3, “z14 performance” on page 74.

### 4.3.2 Capacity on demand

The z14 continues to provide capacity on-demand (CoD) offerings. They provide flexibility and control to the client, ease the administrative burden in the handling of the offerings, and give the client finer control over resources that are needed to meet the resource requirements in various situations.

The z14 can perform concurrent upgrades, providing an increase of processor capacity with no server outage. In most cases, with operating system support, a concurrent upgrade can also be nondisruptive to the operating system. It is important to consider that these upgrades are based on the enablement of resources already physically present in the z14.

Capacity upgrades cover both permanent and temporary changes to the installed capacity. The changes can be done by using the Customer Initiated Upgrade (CIU) facility, without requiring IBM service personnel involvement. Such upgrades are initiated through the web by using IBM Resource Link. Use of the CIU facility requires a special contract between the client and IBM, through which terms and conditions for online CoD buying of upgrades and other types of CoD upgrades are accepted. For more information, see the IBM Resource Link.

For more information about the CoD offerings, see [IBM z14 Technical Guide, SG24-8451](#).

### **Permanent upgrades**

Permanent upgrades of processors (CP, IFL, ICF, zIIP, and SAP) and memory, or changes to a platform's Model-Capacity Identifier, up to the limits of the installed processor capacity on an existing z14, can be performed by the client through the IBM Online Permanent Upgrade offering by using the CIU facility.

### **Temporary upgrades**

Temporary upgrades of a z14 can be done by On/Off CoD, Capacity Backup (CBU), or Capacity for Planned Event (CPE) ordered from the CIU facility.

#### ***On/Off CoD function***

On/Off CoD is a function that is available on the z14 that enables concurrent and temporary capacity growth of the CPC. On/Off CoD can be used for client peak workload requirements, for any length of time, has a daily hardware charge and can have an associated software charge. On/Off CoD offerings can be prepaid or post-paid. Capacity tokens are available on z14. Capacity tokens are always present in prepaid offerings and can be present in post-paid if the client wants that. In both cases, capacity tokens are being used to control the maximum resource and financial consumption.

When using the On/Off CoD function, the client can concurrently add processors (CP, IFL, ICF, zIIP, and SAP), increase the CP capacity level, or both.

#### ***Capacity Backup function***

CBU allows the client to perform a concurrent and temporary activation of additional CP, ICF, IFL, zIIP, and SAP, an increase of the CP capacity level, or both. This function can be used during an unforeseen loss of Z capacity within the client's enterprise, or to perform a test of the client's disaster recovery procedures. The capacity of a CBU upgrade cannot be used for peak workload management.

CBU features are optional and require unused capacity to be available on CPC drawers of the backup system, either as unused processor units, as a possibility to increase the CP capacity level on a subcapacity system, or both. A CBU contract must be in place before the LIC-CC code that enables this capability can be loaded on the system.

An initial CBU record provides for one test for each CBU year (each up to 10 days in duration) and one disaster activation (up to 90 days in duration). The record can be configured to be valid for up to five years. Client can also order additional tests for a CBU record if needed, in quantities of five tests up to a maximum of 15.

Proper use of the CBU capability does not incur any additional software charges from IBM.

### **Capacity for Planned Event function**

CPE allows the client to perform a concurrent and temporary activation of additional CPs, ICFs, IFLs, zIIPs, and SAPs, an increase of the CP capacity level, or both. This function can be used during a planned outage of Z capacity within the client's enterprise (for example, data center changes, system or power maintenance). CPE cannot be used for peak workload management and can be active for a maximum of three days.

The CPE feature is optional and requires unused capacity to be available on CPC drawers of the backup system, either as unused processor units, as a possibility to increase the CP capacity level on a subcapacity system, or both. A CPE contract must be in place before the LIC-CC that enables this capability can be loaded on the system.

### **z/OS capacity provisioning**

Capacity provisioning helps clients manage the CP and zIIP capacity of z14 that is running one or more instances of the z/OS operating system. By using the z/OS Capacity Provisioning Manager (CPM) component, On/Off CoD temporary capacity can be activated and deactivated under control of a defined policy. Combined with functions in z/OS, the z14 provisioning capability gives the client a flexible, automated process to control the configuration and activation of On/Off CoD offerings.

## **4.3.3 z14 performance**

The Z microprocessor chip of the z14 has a high-frequency design that uses IBM leading technology and offers more cache per core than other chips. In addition, an enhanced instruction execution sequence, along with processing technologies such as SMT, delivers world-class per-thread performance. z/Architecture is enhanced by providing more instructions, including SIMD, that are intended to deliver improved CPU-centric performance and analytics.

For CPU-intensive workloads, more gains can be achieved by multiple compiler-level improvements. Improved performance of the z14 is a result of the enhancements that are described in Chapter 2, "IBM z14 hardware overview" on page 17 and in 4.1, "Technology improvements" on page 58.

The z14 Model M05 offers up to 35% more capacity than the largest z13 system. Uniprocessor performance also increased significantly. Single processor capacity of a z14 is approximately 10% greater than that of a z13 with equal *n*-way configurations. Performance will vary depending on workload type and configuration.

### **LSPR workload suite: z14 changes**

To help you better understand workload variations, IBM provides a no-cost tool, zPCR, which is available at the [IBM Presentation and Tools](#) website.

IBM continues to measure performance of the systems by using various workloads and publishes the results in the [Large Systems Performance Reference \(LSPR\) report](#).

IBM also provides a list of [MSU ratings](#) for reference.

Capacity performance is closely associated with how a workload uses and interacts with a particular processor hardware design. Workload capacity performance is sensitive to three major factors:

- ▶ Instruction path length
- ▶ Instruction complexity
- ▶ Memory hierarchy



The CPU measurement facility (MF) data allows you to gain insight into the interaction of workload with the hardware design. CPU MF data helps LSPR to adjust workload capacity curves that are based on the underlying hardware sensitivities, in particular the processor access to caches and memory. This is known as *nest activity intensity*. With the Z, the LSPR introduced three workload capacity categories that replace all prior primitives and mixes:

- ▶ **LOW** (relative nest intensity): A workload category that represents light use of the memory hierarchy.
- ▶ **AVERAGE** (relative nest intensity): A workload category that represents average use of the memory hierarchy. This category is expected to represent most production workloads.
- ▶ **HIGH** (relative nest intensity): A workload category that represents heavy use of the memory hierarchy.

These categories are based on the relative nest intensity, which is influenced by many variables, such as application type, I/O rate, application mix, CPU usage, data reference patterns, LPAR configuration, and the software configuration that is running, among others. CPU MF data can be collected by z/OS System Measurement Facility on SMF 113 records or z/VM Monitor starting with z/VM V5R4.

In addition to low, average, and high categories, the latest zPCR provides the low-average and average-high mixed categories, which allow better granularity for workload characterization.

The LSPR tables continue to rate all z/Architecture processors running in LPAR mode and 64-bit mode. The single-number values are based on a combination of the default mixed workload ratios, typical multi-LPAR configurations, and expected early-program migration scenarios. In addition to z/OS workloads used to set the single-number values, the LSPR tables contain information that pertains to Linux and z/VM environments.

The LSPR contains the internal throughput rate ratios (ITRRs) for the z14 and the previous generations of processors that are based on measurements and projections using standard IBM benchmarks in a controlled environment. The actual throughput that any user might experience varies depending on several factors, such as the amount of multiprogramming in the user's job stream, the I/O configuration, and the workload processed.

Experience demonstrates that Z platforms can be run at up to 100% utilization levels, sustained. However, most clients prefer to leave a bit of white space and run at 90% or slightly under. For any capacity comparison, using “one number,” such as the MIPS or MSU metrics, is not a valid method. That is why, when planning for capacity, use zPCR and involving IBM technical support. For more information about z14 performance, see [IBM z14 Technical Guide, SG24-8451](#).

## Throughput optimization with z14

The memory and cache structure implementation in the CPC drawers of the z14 were significantly enhanced compared to previous generations, to provide sustained throughput and performance improvements. Although the memory is distributed throughout the CPC drawers and the CPC drawers have individual levels of caches that are private to the cores and shared by the cores, all processors have access to the highest level of caches and all of the memory. Thus, the system is managed as a memory coherent symmetric multiprocessor (SMP).

Processors within the z14 CPC drawer structure have different distance-to-memory attributes. As described earlier, CPC drawers are fully interconnected to minimize the distance. Other non-negligible effects result from data latency when grouping and dispatching work on a set of available logical processors. To minimize latency, the system attempts to dispatch and later redispatch work to a group of physical CPUs that share cache levels.

PR/SM manages the use of physical processors by logical partitions by dispatching the logical processors on the physical processors. But PR/SM is not aware of which workloads are being dispatched by the operating system in what logical processors. The Workload Manager (WLM) component of z/OS has the information at the task level, but is unaware of physical processors.

This disconnect is solved by enhancements that enable PR/SM and WLM to work more closely together. They can cooperate to create an affinity between task and physical processor rather than between logical partition and physical processor, which is known as *HiperDispatch*.

### **HiperDispatch**

HiperDispatch, introduced with the z10 Enterprise Class, and evolved in z196 and zEC12, was further enhanced in z13 and z14. It combines two functional enhancements, one of which is in the z/OS dispatcher and the other in PR/SM. This function is intended to improve computing efficiency in the hardware, in z/OS, and in z/VM.

In general, the PR/SM dispatcher assigns work to the minimum number of logical processors that are needed for the priority (weight) of the LPAR. On z14, PR/SM attempts to group the logical processors into the same logical cluster or in the neighbor logical cluster in the same CPC drawer and, if possible, in the same chip. This configuration results in reducing the multi-processor effects, maximizing use of shared cache, and lowering the interference across multiple partitions.

The z/OS dispatcher is enhanced to operate with multiple dispatching queues, and tasks are distributed among these queues. Specific z/OS tasks can be dispatched to a small subset of logical processors. PR/SM ties these logical processors to the same physical processors, improving the hardware cache reuse and locality of reference characteristics, such as reducing the rate of cross communication.

To use the correct logical processors, the z/OS dispatcher obtains the necessary information from PR/SM through interfaces that are implemented on the z14. The entire z14 stack (hardware, firmware, and software) tightly collaborates to obtain the full potential of the hardware. z/VM HiperDispatch provides support similar to the one in z/OS. It is possible to dynamically switch on and off HiperDispatch without requiring an initial program load (IPL).

**Note:** HiperDispatch is required if SMT is enabled.

## **4.4 Reliability, availability, and serviceability**

The IBM Z family presents numerous enhancements in reliability, availability, and serviceability (RAS). Focus was given to reducing the planning requirements, while continuing to reduce planned, scheduled, and unscheduled outages. One of the contributors to scheduled outages are Licensed Internal Code (LIC) driver updates that are performed in support of new features and functions. Enhanced Driver Maintenance (EDM) can help reduce the necessity and eventual duration of a scheduled outage.

When properly configured, the z14 can concurrently activate a new LIC Driver level. Concurrent activation of the select new LIC Driver level is supported at specifically released synchronization points. However, for certain LIC updates, a concurrent update or upgrade might not be possible.

z14 builds on the RAS characteristics of the z13 family, with the following RAS improvements:

- ▶ z14 Level 3 cache enhancements using powerful symbol ECC to extend the reach of prior z13 cache and memory improvements for improved availability. The level 3 cache powerful symbol ECC is designed to make it resistant to more failure mechanisms. The z13 hardened the level 4 cache and the main memory was hardened with RAIM before that.
- ▶ Preemptive DRAM marking added to the main memory to isolate and recover failures more quickly.
- ▶ Improved small array error handling in the processor cores.
- ▶ Additional error thresholding to the processor core to isolate “sick but not dead” failure scenarios.
- ▶ An increase in the number of *Resource Groups* (from 2 to 4) to reduce the impact of firmware updates and failures.
- ▶ The addition of an OSA-Express6S TCP checksum on large sends.

z14 continues to support enhanced drawer availability (EDA) which minimizes the effects of CPC drawer repair and upgrade actions. In a multiple CPC drawer system, a single CPC drawer can be concurrently removed and reinstalled for an upgrade or repair. To ensure that the z14 configuration supports removal of a CPC drawer with minimal effect to the workload, consider the Flexible Memory option (see “Flexible memory” on page 61).

z14 also continues to have redundant array of independent memory<sup>5</sup> (RAIM) that provides a method to increase memory availability, where a fully redundant memory system can identify and correct memory errors without stopping. The implementation is similar to the RAID concept used in storage systems for a number of years. For a detailed description of RAS features, see *IBM z14 Technical Guide*, SG24-8451.

The z14 can consist of a maximum of four horizontal CPC drawers that are designed as a field replaceable unit (FRU). Connections among the CPC drawers are established through symmetric multiprocessing (SMP) cables. Each CPC drawer consists of two CP clusters and contains either five or six central processor (CP) single-chip modules (SCMs) and one storage controller (SC) SCM. In addition to SCMs, CPC drawers host memory DIMMs, connectors for I/O, oscillator interface, and manifolds.

A redundant pair of Distributed Converter Assemblies (DCAs) step down the bulk power and connect to 10 point of load (POL) cards, which provide power conversion and regulation. Two redundant oscillators are connected to the drawers through an isolated backplane. Time domain reflectometry (TDR) techniques are applied to isolate failures on the SMP cables, between chips (PU-PU, PU-SC, and SC-SC), and between the processor unit chips and DIMMs. Additional redundancy is designed into new N+1 System Control Hubs (SCHs) and associated power supplies, and 1U Support Elements (SEs).

z14 inherits I/O infrastructure reliability improvements from z13, including Forward Error Correction (FEC) technology that enables better recovery of FICON channels facilitated. An air-cooled z14 configuration features a fully-redundant N+1 radiator pump design that cools the processor unit chips through a water manifold FRU.

The following list describes further RAS enhancements:

- ▶ Integrated sparing
- ▶ Error detection and recovery improvements in caches and memory

---

<sup>5</sup> Meaney, P.J.; Lastras-Montano, L.A.; Papazova, V.K.; Stephens, E.; Johnson, J.S.; Alves, L.C.; O'Connor, J.A.; Clarke, W.J., “IBM zEnterprise redundant array of independent memory subsystem,” *IBM Journal of Research and Development*, vol.56, no.1.2, pp.4:1,4:11, Jan.-Feb. 2012, doi: 10.1147/JRD.2011.2177106

- ▶ 10GbE RoCE Express2
- ▶ PCIe coupling links
- ▶ Fibre Channel Protocol support for T10-DIF
- ▶ A fixed HSA with its size increased to 192 GB on the z14
- ▶ OSA firmware changes to increase the capability of concurrent maintenance change level (MCL) updates
- ▶ A radiator cooling system with N+1 redundancy
- ▶ New CFCC level
- ▶ IBM RMF™ reporting

z14 continues to support concurrent addition of resources, such as processors or I/O cards, to an LPAR to achieve better serviceability. If an additional SAP is required on a z14 (for example, as a result of a disaster recovery situation), the SAPs can be concurrently added to the CPC configuration.

Concurrently adding CP, zIIP, IFL, and ICF processors to an LPAR is possible. This function is supported by z/VM, and also (with appropriate PTFs) by z/OS and z/VSE. Previously, proper planning was required to add CP, zAAP, and zIIP to a z/OS LPAR concurrently. Concurrently adding memory to an LPAR is possible. This is supported by z/OS and z/VM.

z14 supports adding Crypto Express features to an LPAR dynamically by changing the cryptographic information in the image profiles. Users can also dynamically delete or move Crypto Express features. This enhancement is supported by z/OS, z/VM, and Linux on z Systems.

#### 4.4.1 RAS capability for the Support Element

Enhancements are made to the SE design for z14. Notebooks that were used on prior generations of Z servers have been replaced with rack-mounted 1U servers in a redundant configuration on z14. The more powerful SEs offer RAS improvements such as ECC memory, redundant physical networks for SE networking requirements, redundant power modules, and better thermal characteristics.

#### 4.4.2 RAS capability for the Hardware Management Console

Enhancements are also made to the Hardware Management Console (HMC) designs for z14. New for z14 is an option to order 1U servers for traditional and ensemble HMC configurations. This 1U HMC offers the same RAS improvements as those of the 1U SE. The 1U HMC option is a customer-supplied rack and power consolidation solution that can save space in data centers. The MiniTower design used prior to z14 is still available.

### 4.5 High availability with Parallel Sysplex

The Z platform is known for its RAS capabilities, of which Parallel Sysplex is an exponent. The Parallel Sysplex technology is a clustering technology for logical and physical servers, allowing highly reliable, redundant, and robust Z technology to achieve near-continuous availability. Both hardware and software tightly cooperate to achieve this result.

A Parallel Sysplex has the following minimum components:

- ▶ Coupling facility (CF)

This is the cluster center. It can be implemented either as an LPAR of a stand-alone Z platform, or as an additional LPAR of a Z platform where other LPARs are running. Processor units that are characterized as either CPs or ICFs can be configured to this LPAR. ICFs are often used because they do not require any software license charges. Two or more CFs are recommended for availability.

- ▶ Coupling Facility Control Code (CFCC)

This IBM LIC is both the operating system and the application that runs in the CF. No other code runs in the CF. The code is used to create and maintain the structures. These structures are exploited under z/OS by software components such as z/OS itself, DB2 for z/OS, CICS TS, WebSphere MQ, and others.

CFCC can also run in a z/VM virtual machine (as a z/VM guest system). In fact, a complete sysplex can be set up under z/VM, allowing, for instance, testing and operations training. This setup is not recommended for production environments.

- ▶ Coupling links

These are high-speed links that connect the several system images (each running in its own logical partition) that participate in the Parallel Sysplex. At least two connections between each physical server and the CF must exist. When all of the system images belong to the same physical server, internal coupling links are used.

On the software side, the z/OS operating system uses the hardware components to create a Parallel Sysplex. One example of z/OS and CF collaboration is the system-managed CF structure duplexing, which provides a general-purpose, hardware-assisted, easy-to-use mechanism for duplexing structure data held in CFs. This function provides a robust recovery mechanism for failures, such as loss of a single structure on CF or loss of connectivity to a single CF. The recovery is done through rapid failover to the other structure instance of the duplex pair.

If you are interested in deploying system-managed CF structure duplexing, read the technical paper *System-Managed CF Structure Duplexing*, ZSW01975USEN, which you can access by clicking **Learn more** on the [Parallel Sysplex](#) website.

**Note:** z/TPF can also use the CF hardware components. However, the term *sysplex* exclusively applies to z/OS usage of the CF.

Normally, two or more z/OS images are clustered to create a Parallel Sysplex. Multiple clusters can span several Z platforms, although a specific image (logical partition) can belong to only one Parallel Sysplex.

A z/OS Parallel Sysplex implements shared-all access to data. This configuration is facilitated by Z I/O virtualization capabilities such as MIF. MIF allows several logical partitions to share I/O paths in a secure way, maximizing use and greatly simplifying the configuration and connectivity.

In short, a Parallel Sysplex comprises one or more z/OS operating system images that are coupled through one or more coupling facilities. A properly configured Parallel Sysplex cluster is designed to maximize availability *at the application level*. Rather than a quick recovery of a failure, the Parallel Sysplex design objective is *zero failure*.

The following are the major characteristics of a Parallel Sysplex:

▶ Data sharing with integrity

The CF is key to the implementation of share-all access to data. Every z/OS system image has access to all the data. Subsystems in z/OS declare resources to the CF. The CF accepts and manages lock and unlock requests on those resources, helping ensure data integrity. A duplicate CF further enhances the availability. Key users of the data sharing capability are DB2, WebSphere MQ, WebSphere ESB, IMS, and CICS.

Because these are major infrastructure components, applications that use them inherently benefit from sysplex characteristics. For example, many large SAP implementations have the database component on DB2 for z/OS in a Parallel Sysplex.

▶ Continuous (application) availability

Changes, such as software upgrades and patches, can be introduced one image at a time, while the remaining images continue to process work. For more information, see [Improving z/OS Application Availability by Managing Planned Outages, SG24-8178](#).

▶ High capacity

Parallel Sysplex scales 2 - 32 images. Each image can have 1 - 170 processor units. The scalability is near-linear as additional z/OS images are added to a sysplex. This structure contrasts with other forms of clustering that employ n-to-n messaging, which leads to rapidly degrading performance with a growing number of nodes.

▶ Dynamic workload balancing

Because the system is viewed as a single logical resource, work can be directed to any of the Parallel Sysplex cluster operating system images where capacity is available.

▶ Systems management

This architecture provides the infrastructure to satisfy a client requirement for continuous availability and enables techniques for achieving simplified systems management consistent with this requirement.

▶ Resource sharing

A number of base z/OS components use CF shared storage. This usage enables the sharing of physical resources with significant improvements in cost, performance, and simplified systems management.

▶ Single system image

The collection of system images in the Parallel Sysplex is displayed as a single entity to the operator, user, database administrator, and so on. A single-system image ensures reduced complexity from both operational and definition perspectives.

▶ N-2 support

Multiple hardware generations (normally three, which are the current and the two previous ones) are supported in the same Parallel Sysplex. This configuration provides for a gradual evolution of the systems in the Sysplex, without forcing you to change them all simultaneously. Similarly, software support for multiple releases or versions is supported.

▶ CF Encryption support

Provides support for encrypted data while it is being transferred to and from the CF as it resides in the Coupling Facility Structure:

- z/OS Systems must have the cryptographic hardware configured and activated to perform cryptographic functions and hold AES master keys within a secure boundary. Feature 3863, CPACF DES/TDES Enablement must be installed to use the Crypto Express4 Coprocessor (CEX4C), the Crypto Express5 Coprocessor (CEX5C) or the Crypto Express6 Coprocessor (CEX6C) feature.

- Support provided can only be enabled when all systems are z/OS 2.3 or higher. Toleration support with reduced functionality will be provided for z/OS 2.2 and z/OS 2.1.

► Dynamic activation of I/O configurations for stand-alone CFs

Dynamic I/O configuration changes can be made to a stand-alone CFs without requiring a disruptive reset. An LPAR with a firmware-based appliance version of a HCD instance is used to apply the new I/O configuration changes. The LPAR on a z 14 or z14 ZR1 is driven by an updated HCD instance that is running in a z/OS LPAR on a remote z14 or z14 ZR1.

**Note:** This function requires new z14 firmware support for the stand-alone CF. To enable this function, an IML or POR action must be performed on the stand-alone CF after the firmware is installed. Firmware support is also required on the connected Z platform where the HCD instance resides.

► Improved performance and resiliency

Asynchronous Cache Cross-Invalidation is a new sysplex capability for performance, scalability, and improved cross-site operation. This function allows the cache coherency messages that flow across the sysplex to maintain data integrity to be performed in an asynchronous fashion rather than synchronously, with exploitation from the data manager (Db2). Asynchronous Cache Cross-Invalidation is expected to reduce CF cache structure service times and sysplex coupling overhead, particularly in sysplex environments that involve multiple sites with significant cross-site distances. This function requires PTFs for z/OS and Db2.

Figure 4-5 shows the components of a Parallel Sysplex as implemented within the Z architecture. The diagram shows one of many possible Parallel Sysplex configurations.

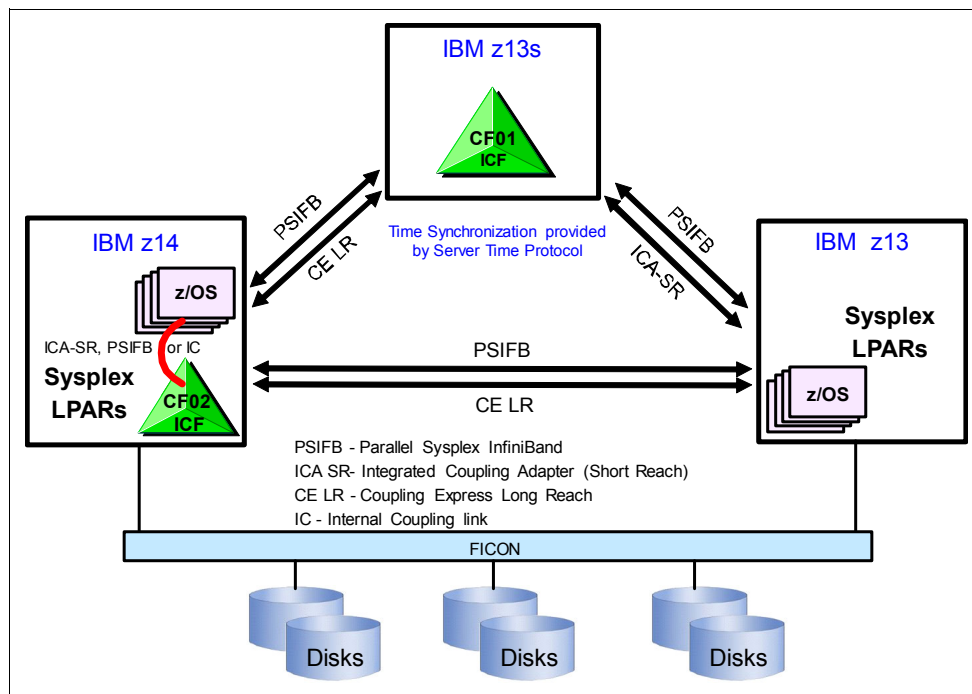

Figure 4-5 Sysplex hardware overview

Figure 4-5 shows a z14 that contains multiple z/OS sysplex partitions and an internal coupling facility (CF02), a z13s server containing a stand-alone CF (CF01), and a z13 containing multiple z/OS sysplex partitions. Server Time Protocol (STP) over coupling links provides time synchronization to all servers.

Appropriate CF link technology (1x IFB, 12x IFB, ICA-SR, or CE-LR) selection depends on server configuration and how distant they are physically located. ICA-SR links can only be used within a short distance, while a CE-LR can support a distance up to 10 km. See 3.7, “Coupling and clustering” on page 50 for more information about coupling link options.

## 4.6 Pervasive encryption

Data protection and security are business imperatives, and regulatory compliance is increasing in complexity. Extensive use of encryption is one of the best ways to reduce the risks and financial losses of a data breach and meet complex compliance mandates. However, implementing encryption can be a complex process for organizations. They need to determine these factors:

- ▶ What data should be encrypted?
- ▶ Where should encryption occur?
- ▶ Who is responsible for encryption?

Because the data is the new perimeter, encryption policies must cover both data in-flight and data at-rest, but should not require costly application changes to achieve this goal. Organizations need a transparent and consumable approach to enable extensive encryption of data in-flight and at-rest to substantially simplify and reduce the costs associated with protecting the data at the core of their enterprise and achieving compliance mandates.

With solutions around privileged identity management, sensitive data protection, and integrated security intelligence, Z security offers the next generation of secure, trusted transactions.

Pervasive encryption is a data-centric approach to information security that entails protecting data entering and exiting the z14 platform. It involves encrypting data in-flight and at-rest to meet complex compliance mandates and reducing the risks and financial losses of a data breach. It is a paradigm shift from selective encryption (where only the data that is required to achieve compliance is encrypted) to pervasive encryption. Pervasive encryption with z14 is enabled through tight platform integration that includes these features:

- ▶ Integrated cryptographic hardware: CPACF is a co-processor on every processor unit that accelerates encryption. Crypto Express features can be used as hardware security modules (HSMs)<sup>6</sup>.
- ▶ Data set and file encryption: You can protect Linux file systems and z/OS data sets by using policy-controlled encryption that is transparent to applications and databases.
- ▶ Network encryption: You can protect network data traffic by using standards-based encryption from endpoint to endpoint.
- ▶ Full disk encryption: You can use disk drive encryption that protects data at rest when disk drives are retired, sent for repair or repurposed.
- ▶ CF encryption: Secures the parallel sysplex infrastructure including the CF links and data stored in the CF, using policy-based encryption.

---

<sup>6</sup> An HSM is a physical computing device that safeguards and manages digital keys for strong authentication and provides crypto processing.



- ▶ Secure Service Container: Secure deployment of software appliances including tamper protection during installation and runtime, restricted administrator access, and encryption of data and code in-flight and at-rest

Figure 4-6 shows that data is encrypted when in-flight and at-rest. Data is decrypted only when being processed by the operating system.

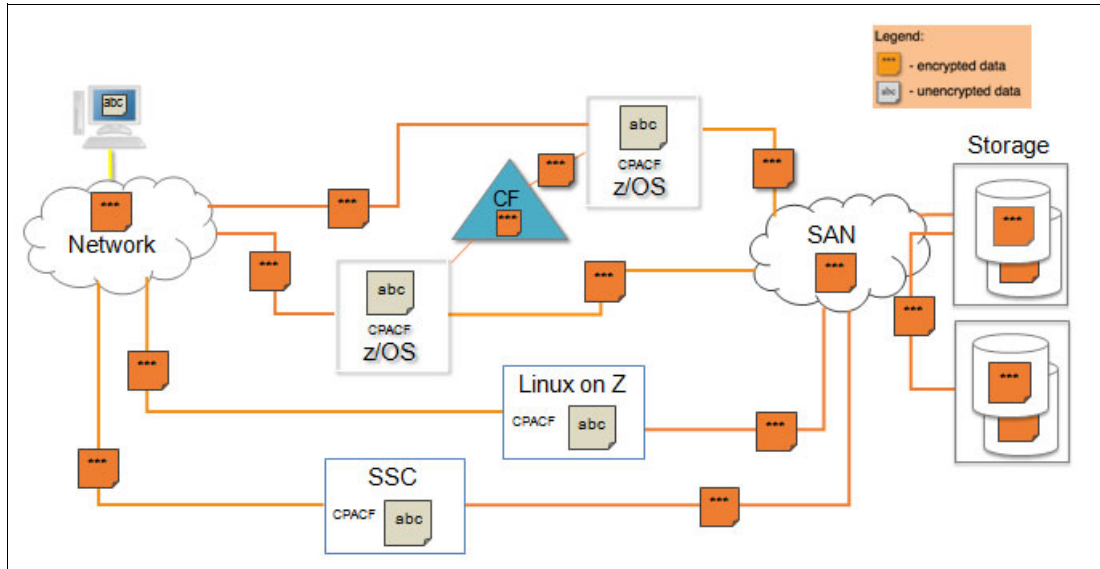

Figure 4-6 Protecting data in-flight and at-rest

Pervasive encryption has the following advantages:

- ▶ The ability to encrypt data by policy without application change
- ▶ A simplified way to protect data at a much coarser scale with industry best performance
- ▶ Greatly simplified audit, enabling clients to pass compliance audits more easily





# Operating system support

This chapter describes the operating system requirements and support considerations for the z14 and their features. It includes the following topics:

- ▶ 5.1, “Software support summary” on page 86
- ▶ 5.2, “Support by operating system” on page 89
- ▶ 5.3, “Software licensing” on page 92
- ▶ 5.4, “References” on page 93

**Note:** Support and use of hardware functions depend on the operating system version and release. This information is subject to change. Therefore, for the most current information, see *z14: Preventive Service Planning (PSP)* bucket for 3906DEVICE.

## 5.1 Software support summary

The software portfolio for the z14 includes various operating systems and middleware that support the most recent and significant technologies. The following major operating systems are supported:

- ▶ z/OS
- ▶ z/VM
- ▶ z/VSE
- ▶ z/TPF
- ▶ Linux on IBM Z
- ▶ KVM for IBM Z

### 5.1.1 Operating systems summary

Table 5-1 on page 87 lists the current and minimum operating system levels that are required to support the z14. Operating system levels that are no longer in service are not covered in this publication. These older levels can provide support for certain features.

**PTFs and PSP buckets:** The use of several features depends on a particular operating system. In all cases, program temporary fixes (PTF) might be necessary with the operating system level indicated.

Preventive Service Planning ([PSP](#)) buckets are continuously updated and reviewed regularly when planning for installation of a new system. They contain the latest information about installation, hardware and software service levels, service recommendations, and cross-product dependencies.

PTFs for z/OS, z/VM, and z/VSE can be ordered electronically from [IBM Shopz](#).

To obtain access to download the z/TPF and z/TPFDF APAR packages, contact [TPFQA@us.ibm.com](mailto:TPFQA@us.ibm.com)

For KVM and Linux on IBM Z distributions, consult the distributor's support information.

Fix packs for IBM software products that are running on Linux on IBM Z can be downloaded from [IBM Fix Central](#).

Table 5-1 z14 operating system requirements

Operating system <sup>a</sup>	End of service	Notes
z/OS V2R3	September 2022 <sup>b</sup>	See the z/OS, z/VM, z/VSE, and z/TPF subsets of the 3906DEVICE Preventive Service Planning (PSP) buckets before installing the z14.
z/OS V2R2	September 2020 <sup>b</sup>	
z/OS V2R1	September 2018 <sup>b</sup>	
z/OS V1R13 <sup>c</sup>	September 2016	
z/VM V7R1	Not announced	
z/VM V6R4	Not announced	
z/VSE V6R2	Not announced	
z/VSE V6R1 <sup>d</sup>	Not announced	
z/VSE V5R2 <sup>e</sup>	October 2018 <sup>b</sup>	
z/TPF V1R1	Not announced	
Linux on IBM Z	Support information is available for SUSE <sup>f</sup> , Red Hat <sup>g</sup> and Ubuntu <sup>h</sup>	
KVM Hypervisor <sup>i</sup>	Offered with the following Linux distributions SLES-12 SP2 or higher, and Ubuntu 16.04 LTS or higher.	

- a. Only z/Architecture mode is supported. See the box titled “z/Architecture mode”.
- b. Planned date. All statements regarding IBM plans, directions, and intent are subject to change or withdrawal without notice. Any reliance on these Statements of Direction is at the relying party’s sole risk and will not create liability or obligation for IBM.
- c. Compatibility only. The IBM Software Support Services for z/OS V1.13, offered as of October 1, 2016, provides the ability for customers to purchase extended defect support service for z/OS V1.13.
- d. z/VSE V6 requires an architectural level set
- e. z/VSE V5 requires an architectural level set
- f. Visit <https://www.suse.com/support/>
- g. Visit <https://www.redhat.com/security/updates/errata/>
- h. Visit <https://www.ubuntu.com/download/server/linuxone>
- i. For minimal and recommended distribution levels refer to the Z website.

**z/Architecture mode:** As announced on January 14, 2015 with Announcement letter 115-001, beginning with z14, all systems will only support operating systems running in z/Architecture mode. This applies to operating systems running native on PR/SM as well as operating systems running as second-level guests. IBM operating systems that run in ESA/390 mode are either no longer in service or only currently available with extended service contracts, and they are not usable on systems beginning with z14. However, z14 does provide ESA/390-compatibility mode, an environment supporting a subset of DAT-off ESA/390 applications in a hybrid architectural mode.

All 24-bit and 31-bit problem state application programs originally written to run on the ESA/390 architecture will be unaffected by this change.

## 5.1.2 Application development and languages

Several programming languages are available for the z14 environments. Because the Linux environment is similar to Linux on other servers, this discussion focuses on the z/OS environment.

In addition to the traditional COBOL, PL/I, Fortran, and Assembler languages, Z platforms support C, C++, and Java (including Java Platform, Enterprise Edition, and batch environments) programming languages also.

Development can be conducted by using the latest software engineering technologies and advanced integrated development environments (IDE). The extensive tool set uses a workstation environment for development and testing, with final testing and deployment performed on z/OS.

IBM Z embraces emerging concepts like DevOps, which is the process of bringing Development and Operations together to share processes and procedures with a goal to reduce the risk of change and improve the speed of deployment. As organizations embark on their journey with digital transformation and enter the API economy, connecting business-critical applications running on mainframes with mobile and cloud applications to better engage with customers becomes more essential. A key step in this evolution is to understand what assets already exist in the enterprise.

IBM's current DevOps offerings, such as IBM Application Delivery Foundation for z and IBM Rational® Team Concert®, coupled with IBM Application Discovery and Delivery Intelligence's (ADDI) application discovery technology, are designed to enable developers to understand the applications, gain cognitive insights into the process and evolve those valuable legacy assets at the speed of business with reduced risk to the enterprise.

Using modern development practices is part of the transformation. IBM's Rational Team Concert™ and open source based Git Version Control Tools for IBM z/OS (ported by Rocket Software) are modern source code managers (SCM) that run on and support z/OS.

For more information about software for Z platforms, see the [Products catalog website](#).

We cannot emphasize enough the importance of using the most recent versions of the compilers. The compilers enable the use of the latest technologies that are implemented on the system, and take advantage of the performance benefits that are introduced. Examples of benefits include new cache structures, new machine instructions, and instruction execution enhancements.

z14 introduces brand new features and functions, such as Guarded Storage Facility (GSF) enabling less-pausing garbage collection for Java workloads. z14 processors also inherit and further enhance features and functions from its predecessor generation z13, such as the single-instruction, multiple-data (SIMD) which allows the development of smaller and optimized codes to improve efficiency of complex mathematical models and vector processing.

### 5.1.3 IBM compilers

Each new version of IBM z/OS compilers (Enterprise COBOL, Enterprise PL/I, XL C/C++) underscores the continuing IBM commitment to the COBOL, PL/I, and C/C++ programming languages on the z/OS platform.

- ▶ Enterprise COBOL

The most recent version of Enterprise COBOL uses the most recent z/Architecture and performance optimization, enhanced XML parsing support, and capability of programming with Unicode, and supports Java 8 SDKs for Java interoperability. It delivers new COBOL statements, new and changed compiler options, and changed APIs.

- ▶ IBM Automatic Binary Optimizer for z/OS

The Automatic Binary Optimizer for z/OS improves the performance of already compiled COBOL programs. The Optimizer does not require source code, source code migration, or performance options tuning. It uses modern optimization technology to target Z, including z14, z13, z13s, zEC12, and zBC12, to accelerate the performance of existing compiled COBOL applications.

- ▶ Enterprise PL/I

The latest version of Enterprise PL/I provides web interoperability, which includes web services, XML parsers, and Java Platform, Enterprise Edition (Java EE). The compiler also includes the expanded support for UTF-16. Enterprise PL/I for z/OS allows you to capitalize on existing IT investments while modernizing your infrastructure.

- ▶ z/OS XL C/C++

The z/OS XL C/C++ uses the latest z/Architecture, including z14 servers. It enables developing high performance-oriented applications, through the services provided by IBM Language Environment and Runtime Library extension base elements, and works in concert with z/OS problem determination tools.

IBM Enterprise COBOL and Enterprise PL/I support are strategic components (separately orderable products) for IBM Rational Developer for IBM Z software. These features provide a robust, integrated development environment (IDE) for COBOL and PL/I and connecting web services, Java Platform, Enterprise Edition (Java EE) applications, and traditional business processes.

z/OS XL C/C++ programmers can also tap into Rational Developer for z to help boost productivity by editing, compiling, and debugging z/OS XL C and XL C++ applications right from the workstation.

## 5.2 Support by operating system

This section lists the support by in-service operating systems of selected functions of the z14.

For a detailed description of the z14 and its features, see *IBM z14 Technical Guide*, SG24-8451. For an in-depth description of all I/O features, see [IBM Z Connectivity Handbook, SG24-5444](#).

## 5.2.1 z/OS

z/OS Version 2 Release 1 is the earliest in-service release that supports z14 servers. Although service support for z/OS Version 1 Release 13 ended in September of 2016, a fee-based extension for defect support (for up to three years) can be obtained by ordering IBM Software Support Services - Service Extension<sup>1</sup> for z/OS 1.13.

z14 capabilities differ depending on the z/OS release. Toleration support is provided on z/OS V1R13. Exploitation support is provided only on z/OS V2R1 and later via PTFs.

See *IBM z14 Technical Guide*, SG24-8451 for all z14 features and functions supported by the z/OS releases.

## 5.2.2 z/VM

z/VM V6R4 provides support that enables guests to use functions that are supported by z/VM on z14, which includes:

- ▶ z/Architecture support
- ▶ New hardware facilities
- ▶ ESA/390-compatibility mode for guests
- ▶ Crypto Clear Key ECC operations
- ▶ Encrypted paging support
- ▶ Guest exploitation support:
  - Pause-less garbage collection for Java
  - Instruction Execution Protection Facility
- ▶ Dynamic I/O support for managing the configuration of:
  - OSA-Express7S and OSA-Express6S for OSD and OSX CHPID types
  - FICON Express16S+ for FC and FCP CHPID types
  - zHyperLink Express
  - Coupling Express LR
  - 25GbE RoCE Express2
  - 10GbE RoCE Express2
- ▶ Improved memory management support

**z/VM logical partitions:** z14 CPs and IFLs have increased capacity over that of their predecessors. Therefore, we suggest that the capacity of z/VM logical partitions and of any guests, in terms of the *number* of IFLs and CPs (real or virtual), be reviewed and adjusted to achieve the required capacity. Virtual machine might also need adjustment.

IBM z/VM V7.1 offers a new release delivery and new function support that provides predictability for lifecycle management of z/VM systems through continuous delivery. z/VM V7.1 includes the following enhancements:

- ▶ Integration of the Single System Image (SSI) function into the base, at no extra cost
- ▶ Enhancements to the dump process to reduce the time required to create and process dumps
- ▶ Upgrades to a new Architecture Level Set

<sup>1</sup> Beginning with z/OS V1.12, IBM Software Support Services replaced the IBM Lifecycle Extension for z/OS offering with a service extension for extended defect support.



- ▶ More functionality will be delivered as service after general availability
- ▶ Enhancements to the dynamic configuration capabilities of a running z/VM system with Dynamic Memory Downgrade support

For more information about PTF availability, see the [z/VM Continuous Delivery News web page](#).

For more information about all z14 features and functions that are supported by the z/VM releases, see *IBM z14 Technical Guide*, SG24-8451.

### 5.2.3 z/VSE

z14 support is provided by z/VSE V5R2 and later. Note the following considerations:

- ▶ z/VSE runs in z/Architecture mode only.
- ▶ z/VSE supports 64-bit real and virtual addressing.
- ▶ z/VSE V5 has an architectural level set (ALS) that requires IBM System z9® or later.
- ▶ z/VSE V6 has an ALS that requires IBM System z10® or later.

For more information about all z14 features and functions that are supported by the z/VSE releases, see *IBM z14 Technical Guide*, SG24-8451.

### 5.2.4 z/TPF

z14 support is provided by z/TPF V1R1 with PTFs. For more information about all z14 features and functions that are supported by the z/TPF, see *IBM z14 Technical Guide*, SG24-8451.

### 5.2.5 Linux on IBM Z

Table 5-2 lists the service levels of SUSE, Red Hat, and Ubuntu releases supported at the time of writing.

Table 5-2 Current Linux on IBM Z distributions

Linux on Z distribution <sup>a</sup>	Earliest supported version and release <sup>b</sup>
SUSE Linux Enterprise Server	SLES 12 SP2 with service
SUSE Linux Enterprise Server	SLES 11 SP4 with service
Red Hat Enterprise Server	RHEL 7.3 with service
Red Hat Enterprise Server	RHEL 6.9 with service
Canonical	Ubuntu 16.04 LTS with service

a. Only z/Architecture (64-bit mode) is supported. IBM testing identifies the “minimum required level” and the “recommended levels” of the tested distributions.

b. Fix installation is required for toleration.

For more information about supported Linux distributions on Z platforms, see [the Linux on IBM Z page](#) of the IBM Z website.

For more information about all z14 features and functions that are supported by the Linux on IBM Z distributions, see *IBM z14 Technical Guide*, SG24-8451.

## 5.2.6 KVM hypervisor

With Announcement Letter 917-04, dated March 7, 2017, IBM announced that it is working with Linux distributions to support the KVM component on IBM Z.

For more information about KVM support for the Z platform, see your distribution's documentation.

## 5.3 Software licensing

The z14 software portfolio includes operating system software (that is, z/OS, z/VM, z/VSE, and z/TPF) and middleware that runs on these operating systems. The portfolio also includes middleware for Linux on IBM Z environments. For the z14, the following metric groups for software licensing are available from IBM, depending on the software product:

- ▶ Monthly license charge (MLC)

MLC pricing metrics have a recurring charge that applies each month. In addition to the permission to use the product, the charge includes access to IBM product support during the support period. MLC pricing applies to z/OS, z/VSE, and z/TPF operating systems. Charges are based on processor capacity, which is measured in millions of service units (MSU) per hour.

- ▶ IPLA

IPLA metrics have a single, up-front charge for an entitlement to use the product. An optional and separate annual charge, called *subscription and support*, entitles clients to access IBM product support during the support period. With this option, you can also receive future releases and versions at no additional charge.

### Software Licensing References

For more information about software licensing, see the following websites:

- ▶ [Learn about Software licensing](#)
- ▶ [Base license agreements](#)
- ▶ [IBM Z Software Pricing reference guide](#)
- ▶ [IBM Z Software Pricing](#)
- ▶ [The IBM International Passport Advantage® Agreement](#) can be downloaded from the "Learn about Software licensing" website

### Sub-capacity pricing terms for z/VM and select z/VM-based programs

Sub-capacity pricing for the z/VM V6 operating environment is available to clients running z/VM Version 6 Release 3 or higher. Software pricing at less than full machine capacity can provide more flexibility and improved cost of computing as you manage the volatility and growth of new workloads.

For more information about Sub-capacity pricing terms for z/VM and z/VM-based programs, see announcement letter 217-267, dated July 17, 2017.

For more information about available software licensing options for z14, see *IBM z14 Technical Guide*, SG24-8451.

## 5.4 References

For current planning information, see the landing pages for each of the following operating systems:

- ▶ [z/OS](#)
- ▶ [z/VM](#)
- ▶ [z/VSE](#)
- ▶ [z/TPF](#)
- ▶ [Linux on IBM Z](#)
- ▶ [KVM for IBM Z](#)



**Redbooks**

**IBM z14 Technical Introduction**

(0.2" spine)  
0.17" x 0.473"  
90 x 249 pages







SG24-8450-01

| ISBN 0738457191

Printed in U.S.A.

Get connected

