



INTERNATIONAL SNOWMOBILE RACING

1527 North Railroad Street Eagle River, WI 54521

262-335-2401

VINTAGE OVAL 2022-2023 VERIFICATION AND CONTROL

These GENERAL RULES apply to all types of ISR racing sanctions and all classes unless so noted. All participants, racers and crewmembers are required to be fully aware of these regulations and must abide by them.

The rules for competition are intended only as a guide for the conduct of the sport in a uniform manner from region to region.

Safety rules and guidelines contained herein are of utmost importance. All participants must be concerned with safety and be familiar with these rules and guidelines. However, ISR does not warrant, guarantee or ensure safety even if the rules are enforced and/or adhered to. Moreover, each participant in competition has the responsibility to assess the safety aspects of the facilities and conditions and must assume the risk of competition.

MANDATORY EMERGENCY VEHICLE

1. A properly licensed and equipped emergency vehicle (i.e., rescue vehicle or ambulance) must be at the race site to transport injured persons to an appropriate hospital. This vehicle shall have all emergency equipment. Contract arrangements must be made to have a transport situation ambulance on site if a transport is made. Many tracks are now using a track owned ambulance for on-site work. Many times, these vehicles are not certified for transport of patients on the highway. Arrangements must be made for a certified transport ambulance to make the actual patient transport. Racing must not be allowed without an ambulance on the grounds.
2. If an event is located at a ski hill facility and it has qualified ski patrol personnel (Paramedics - ALS) and an onsite room fully equipped as an ambulance would be it can be substituted for the actual vehicle. When The terrain and driving distance by ambulance makes it advantageous to use a prearranged air ambulance this method can be used to transport injured persons to an appropriate hospital after stabilization by Ski Patrol personnel. (Paramedics - ALS)

RULE SUPPLEMENTS

1. Rule supplements, additions or corrections shall be announced on the official website. Upon such an announcement the rule changes become effective and enforceable.
2. Telephonic race rules conference calls will be followed up with an information letter to the affected affiliates.
3. After a rules meeting, any request to reconsider a new rule requires a majority vote of the rules committee to approve a revote. Then, a ¾ majority is also required to change the rule.

CLASS DIVISIONS

1. All class entries will not discriminate based on sex. Any qualified member may participate in the approved classes offered in any sanctioned event.
2. A snowmobile will be allowed to race in its respective displacement, or designated performance class, and any larger displacement or performance class, except as noted in specific sections.

REGISTRATION AND ENTRY

1. WAIVER FORMS ARE MANDATORY FOR ALL PERSONNEL IN SECURED AREAS (paddock, staging and track).
2. Driver must have registered at race headquarters and signed a waiver before any runs are made (practice or racing). No one, except officially entered drivers may ride or practice on any racecourse on the day of the event.
3. No refunds of entry or other fees will be made at sanctioned events after registration is closed, unless the event is cancelled or rescheduled by a ruling of the Race Director, after which time fees will be returned or advanced to the next event in the series.
4. Any competitor who pays for race entry or organization membership with a check or credit card is responsible for the payment of all charges should the bank or other institution fail to remit for whatever reason.
5. Drivers who fail to complete payment for entry fees are subject to discipline prescribed by the ISR affiliate. Drivers may be suspended for a period of one year from the date on which the debt is paid.
 - a. If the participant stops payment on check or credit card, participant gives up the right to protest or appeal until full payment is made.
 - b. Participants who pass NSF checks must pay entry and prescribed fees in full before the next race or within 30 days, whichever is sooner.

6. Insurance fees are not refundable.
7. Regional service charges or insurance surcharges are not considered part of entry fee maximums.
8. Gate admission fees for driver and crewmembers will be regulated on a regional basis.
9. The order of events will be regulated on a regional basis.
10. The maximum number of classes a driver can enter per day will be regulated on a regional basis.
11. **Any class or event can be eliminated when there are less than two (3) official entries at the close of registration. (This rule has been in place, for the past seasons, however, it has not been used.) Clarification.**
12. All participants in events must be fully familiar with the rules and regulations, plus such rules by Race Promoters that may be specifically applied to any event.

DRIVER AND SNOWMOBILE

1. A driver and his snowmobile (chassis and engine) shall be considered a unit and once the class has begun, neither will be substituted. If a driver qualified on a snowmobile, both must be in the same final event of the class and/or event.
2. Engine parts may be replaced during the event, except for the crankcase and crankshaft, which may not be replaced.

SPONSOR IDENTIFICATION

1. Anytime the sanctioning organization or sanctioned event has a sponsorship, all members and promoters must meet sponsorship requirements, if drivers' number system is not compromised.
2. Recommended size for any sponsor's required emblem should not exceed sixteen (16) square inches on the front and twenty-four (24) square inches on the back of the driver's uniform.

DRIVER IDENTIFICATION

1. There will be an automatic suspension for drivers who race under another driver's number.
2. All drivers will wear their issued bib or a facsimile thereof. Drivers will be required to keep the snowmobile numbers and drivers' body back numbers in a legible condition. Drivers must either wear a bib with their name and number for the event or their number built into the upper body outer garment worn during competition. Numbers are to be 8 inches high with a one-inch width. Name letters are to be 2 inches high with a 3/8" width.

SNOWMOBILE IDENTIFICATION

1. Snowmobiles will have the appropriate number plate affixed to their race vehicle. Regional and affiliate rules may require background colors and contracting numbers for each class. ISR supports this requirement.

PRE-RACE SAFETY INSPECTION

1. ANY ENTRY IS SUBJECT TO INSPECTION AT ANY TIME UPON REQUEST BY THE RACE DIRECTOR OR TECHNICAL DIRECTOR.
2. Pre-race safety inspections are mandatory at all races. Passing a pre-race safety inspection is no guarantee that a snowmobile complies with all rules for the event. Affiliates may allow prerace safety inspections to be conducted at the first race of a series and allow the sled to compete in subsequent events in the series without reinspection if on track records indicate no evidence crashes during competition.
3. Only snowmobiles having passed pre-race inspection will be allowed on the racetrack.
4. All aspects of modification are contingent on safety inspection by the Technical Director. The Technical Director may remove any snowmobile from competition that does not meet safety requirements.
5. Damaged or broken safety equipment (not including tether switch) not detected during a race is not grounds for disqualification after completion of that race unless black-flagged during the race in question.

MANDATORY TEARDOWN

1. Regardless of snowmobile equipment passing prior inspections, compliance with the rules must be made at the post-race inspection.
2. Once a snowmobile has completed registration to race it may be inspected at any time.
3. Tech Director will select the snowmobiles for mandatory teardown and inspection. Drivers will take their snowmobiles directly to Tech after completing the race. The Tech Director may indicate the area or trailer he wishes the sled to be disassembled in. The snowmobile must remain in Tech until released by the Tech Director or a designated member of the Tech staff.
4. Driver and/or driver's mechanic will perform teardown to point required by the Technical Director.
5. Any driver not reporting to Tech or refusing teardown will be disqualified.
6. Inspected snowmobiles will not be reassembled by the inspection group.
7. Driver and/or driver's mechanic will be the only people allowed in the inspection area.
8. The sanctioning organization assumes no responsibility for impounded snowmobiles.

SEALS

1. Drivers will allow the installation of a seal or seals on the engine and/or body of their racing snowmobiles. To change the seal, mutilate it or try to break it, or re-use it, during the weekend or event where it is installed without the consent of the Race Director, could result in the responsible driver being called before the disciplinary committee for strict discipline. Accidental breakage of the seal must be reported to the Race Director immediately.

PROTESTS

1. All formal protests must be made in writing, by a driver, in competition at the event, from the class in question, on a formal protest form, accompanied by a cash protest fee (protest fee may vary by region or circuit) two hundred and fifty dollars (**\$250.00**) recommended.
2. When the official protest is made with the fee, the item to be protested must be stated (a general protest will not be accepted), teardown will not be complete until protest is found to be valid or proven unwarranted. If the protest is valid, the fee will be returned to the protester. If the protest is invalid, the fee will be given to the protested snowmobile owner for the inconvenience (to be accomplished before the snowmobiles are released from teardown). Affiliates may set an increased fee for a total tear down process in which all areas are inspected. Affiliates have the right to refuse nuisance tear down protests generated by individual personal relationships, or on track activity. This fee may be given to the affiliate, or a charity named by the affiliate.
3. There is no need for formal protests in the case of driving infractions during an event. Reports of such alleged infractions should be made to the Race Director, who in turn will request a report from the flagman or assigned official on the course.
4. Race Director has the authority to determine the validity of a protest.
5. No protests will be accepted that refer to a Race/Technical Director's judgement or decision.
6. It shall not be possible to protest or appeal technical inspection equipment, manual /electronic scoring or manual/electronic timing equipment.
7. Protests must be filed within thirty (30) minutes following the completion of the daily event or within thirty minutes following the official announcement of results for the class in question whichever occurs first. Race directors have the authority to increase the time to file a protest for a competitor but may not shorten the time allowed.
8. Properly filed protests must be addressed by sanctioning body before finalizing class results. ISR must be informed of the protest in writing immediately after the protest is filed. Electronic method of communication preferred.

APPEALS PROCESS

The following appeals process shall be applicable for all ISR affiliates and will be the binding operational guide and procedure statement for all affiliates. For any Affiliate that has an internal Appeals Process, the process will only apply to operations inside the association or company and will not have any bearing on race rule interpretation, infractions, misconduct or other situations that may arise from race activity.

TECHNICAL INFRACTIONS

Driver or team are found in non-compliance with the rules concerning fuel, sled construction, specific dimensions, materials used, or components used not conforming to the rules for each specific class, the following will be the procedure.

Tech Director or Race Director determines infraction and makes the appropriate decision considering the gravity of the offence. The Director may:

- a. Verbally warn driver or team.
- b. Disqualify driver from event for the class specified.
- c. Disqualify driver from all events entered in days competition.
- d. Fine driver, if affiliate has a fine process in place in the affiliates bylaws or published operational guide, and the fine system is published in their membership documents.
- e. Suspend driver or team for season.

ON TRACK INFRACTIONS

Race Director determines infraction and makes the appropriate decision considering the gravity of the offence. The Director may:

- a. Verbally warn driver or team.
- b. Disqualify driver from event for the class specified.
- c. Disqualify driver from all events entered in days competition.
- d. Fine driver, if affiliate has a fine process in place in the affiliates bylaws or published operational guide, and the fine system is published in their membership documents.
- e. Suspend driver or team for season.

If the affected driver feels the decision is not correct, he/she may appeal the decision in the following manner.

1. The Appeal must be presented to the affiliate Race Director in writing using the ISR approved form available from the ISR web site. This form must be presented within 30 minutes of the announcement of the disqualification or penalty. Race directors have the authority to increase the time to file a protest for a competitor but may not shorten the time allowed. The Appeal must be accepted by the affiliate.
2. The affiliate must within 24 hours convene a meeting of the owner/ management/ officials of the affiliate and review the offense/ infraction. If the offense is upheld, the driver/team can request a further appeal to ISR and ask for a review by the rules group for the discipline. ISR has 5 days to conduct such review with the rules committee of the specific discipline.

If the Appeal is found valid, all points, money, prizes, etc. are returned/ awarded to the driver/team.

3. If the offense is upheld, the Affiliate and the Driver/team must inform ISR of the situation within 24 hours of the alleged infraction. ISR will then, within 5 working days conduct a review of the situation, convene the appropriate rule review group from the proper discipline/aspect and render a decision. The decision of this session is binding and has no further appeal.

Affiliates and Drivers must review the Chain of Custody and submission of components/ fuels/ design concepts presented for the Appeal. If the driver/team does not submit samples, exhibits, photos, etc. of the offending component or fuel, the appeal is considered void, and the penalty stands. If the Affiliate does not accept and submit samples, exhibits, photos, etc. of the offending component or fuel, the appeal is considered void, and the penalty is rescinded, and all prize money, awards and points are returned to the driver/team. There is no appeal of any type to this operational chain of evidence and procedure. The Operational Guideline and Appeals Forms are found here:

Down Load Appeal Forms Here

Race Operation Infractions [Click here](#) Rules Interpretation Issues [Click here](#) Business Operation Misconduct [Click here](#)

NOTICE

Driver infractions/ disqualifications in a drag racing, oval racing, Enduro racing, cross country racing, water cross racing, and speed run racing events will be forwarded to all ISR affiliates

NOTICE

Drivers, promoters, or any personnel affiliated with ISR snowmobile events who are banned from racing or subject to other major penalties by one affiliate, having completed the hearing process, the decision shall be honored by all ISR affiliates in that discipline.

PRIZES AND AWARDS

1. All prizes, awards and paybacks shall be presented to the official winners or their appointed representatives at the close of the event, unless specifically advertised otherwise as to the time and place of awards.
2. Drivers will not be required to attend award banquets, parties, ceremonies, etc., to receive prizes, awards or pay-backs, although they are encouraged to cooperate as a courtesy to the promoter.

PIT AND PADDOCK/STAGING AREA

1. Reasonable speeds will be observed in the pit and paddock area. All pit areas are caution zones where utmost in driver awareness is required.
2. Hot pit and staging areas are limited to drivers preparing to race and their pit crewmembers. Minimum age for pit crewmembers in these areas is 14 years old. All persons in these areas must have signed a release and waiver for the event.
3. There is no minimum age for people in paddock, pit parking and cold pit areas. It is recommended that people in these areas be required to sign a release and waiver.

TESTING, TUNE-UP, WARM-UP & PRACTICE

1. Officials must provide proper supervision of the testing areas as well as adequate crowd control to prevent spectators or other persons from moving onto the area.

SUPPORT VEHICLES

1. No unauthorized motorized vehicles will be allowed in the pit or staging area. Snowmobiles must return under their own power. Only disabled snowmobiles may be towed from the track.

DRIVER PROTECTIVE EQUIPMENT

It is the responsibility of the racer to select protective equipment that will conform to ISR guidelines and provide adequate protection. Even though race rules committees and ISR develop guidelines, ISR does not endorse or guarantee specific products or manufacturers of protective equipment. Racers must rely on their own judgment in the selection of helmets and other apparel for protection and durability.

1. Regardless of driver apparel passing prior inspections, compliance with the rules must be made at post-race inspections.
2. **No cameras or digital acquisition devices can be attached to any driver's helmet. This will be in effect anytime a race vehicle is on the track, whether it be a test, practice session, or in competition.**
3. ISR strongly encourages all drivers in all disciplines / divisions to source helmets that continue to display **High Vis Colors/International Orange** that cover 75% for Oval Racing (Late Model and Vintage) to prevent driver injuries during competitive events. Full coverage helmets are mandatory. Helmets will be full protective coverage and carry the 2015 Snell Foundation Approval Code. Helmets carrying European Standard ECE 22.05 are also approved. This is also mandatory in the tune-up area. The helmet must be securely fastened at all times. Helmet must display original ECE, or Snell decal as provided by the manufacturer. Decals that are covered or eliminated will be cause for rejection of the helmet. Enclosed cockpit sled drivers must use a current automotive certified helmet meeting Snell SA specification. **NOTICE: 2022 -2023 Snell approval code will be 2015. Due to supply chain issues Snell helmet standards will remain at 2015 for the 2022-2023 season. For the 2024 season the Snell code will be 2020. If competitors are successful in purchasing a 2020 Snell code helmet, they are highly encouraged to use it.**
4. For Oval Sprint, and Vintage oval: At least one hundred forty-four (144) square inches of visible area on both the driver's front and back (upper body) will be blaze orange in color at all events. Jackets / Pullovers / Jerseys will be teched lying flat on the ground front and back. This is strongly recommended in all other types of racing. This does not apply in Enclosed Cockpit or Outlaw 600 classes.

5. Gloves and clothing, along with at least above ankle leather boots are mandatory (above ankle boot must have a minimum of 6 inches of leather above the ankle).
6. Eye protection mandatory; facemasks may be required at the starting line at the discretion of the Race Director. If corrective lenses are required to drive a motor vehicle, the driver will also be required to wear them when racing.
7. Hearing protection is mandatory in all non-stock classes in all types of competition. Recommended for all stock class competition.
8. The use of upper body protection equipment is mandatory, except for enclosed cockpits. The upper body protection must cover all body areas shown in illustration. It will protect the driver in mid-body and back areas and be capable of resisting penetration and dissipating force of impacts while absorbing the shock of most blows. Typical motocross vests do not meet this rule.
9. Shin and knee guards are mandatory. Shin and knee guards will be worn on both legs. The shin guard must extend from the instep to above the kneecap and be constructed of an impenetrable material.
10. Upper Arm Pads and Elbow pads are highly recommended in all forms of racing.
11. Neck bracing is driver preference and is not required.

Upper Body Protection That Meets ISR Guidelines [Click Here](#)

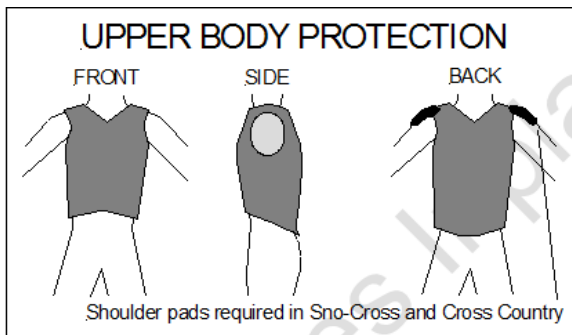

EVS [Click Here](#)

Tek Vest [Click Here](#)

Saf-Jak [Click Here](#)

Leatt Adult [Click Here](#)

Leatt Youth [Click Here](#)

HMK Protective Vest [Click Here](#)

11. Leather suits: See specific requirements in various disciplines.

GENERAL COMPETITION

FLAG RULES

1. There shall be a meeting between the flagman or his representative and corner flagmen prior to the start of a race so there is a definite understanding concerning the use of the corner flags.
2. Any competitor who does not obey the following rules will be subject to disqualification and/or fine.

GREEN FLAG

1. Start of race or signifies course is clear and race is in progress.

YELLOW FLAG

1. Displayed in track corners or along straightaway signifies there is an additional safety hazard on the track.

RED FLAG

1. The red flag means the race will stop immediately regardless of position of snowmobiles on the track. The red flag will be used if, in the opinion of the Race Director or Chief Starter, the track is unsafe to continue the race. Snowmobiles should be brought to the starting line or pre-designated holding area if possible, using extreme caution. Snowmobiles must not leave the track proper unless directed to do so by the Race Director.

BLACK FLAG

1. On closed course races, should a vital snowmobile component such as clutch guards, ski or ski loop become dislodged or discarded, the starter upon his own recognition or being informed by track officials will display the black flag to the involved driver immediately infraction.
2. A rolled black flag is a warning to a driver that he/she may have an equipment failure or that he/she may have committed a driving infraction. Consultation flag-leave course immediately and report to the Race Director, this does not necessarily mean disqualification; however, failure to obey the rolled black flag could result in disqualification, suspension or fine. On closed course races, should a vital snowmobile component such as clutch guards, mud flaps, ski loops or ski become dislodged or discarded, the starter must display the black flag to the involved driver immediately.

WHITE FLAG

1. When displayed, drivers have started their last lap.

CHECKERED FLAG

1. When the checkered flag is displayed, it means the race is complete.

BLUE FLAG WITH YELLOW DIAGONAL

1. For passing/ this flag may be displayed to snowmobiles being lapped or operating in a manner that prevents faster snowmobiles from passing. (Hold Your Line)

SIGNAL LIGHT RULES

1. Sanctioning bodies, which employ signal lights, must inform competitors of their signal light protocol before the start of the event. When light signals are used instead of flags, all competitors must be made aware of signal light procedures prior to the race.
2. Competitors must obey signal lights.
3. The following signals apply to OVAL closed course races:
 - a. GREEN LIGHT-Start of race.
 - b. YELLOW LIGHT-Caution
 - c. RED LIGHT- Stop snowmobile. At the direction of the Race Director, return cautiously to the starting line or designated holding area.

TIMING

1. It is the driver's responsibility to see that his snowmobile triggers the scoring system properly.

RACE STARTING PROCEDURES

1. All drivers must be assembled on the starting line, ready to race within two (2) minutes of notification of their race (except special events). This is defined as when the sleds were summoned to leave the pits. The two-minute clock starts when the first sled of the group leaves the pit and enters the racecourse. All the other sleds in the event/heat/final are required to be on the line within the two- minute window.
2. Snowmobiles may be pushed to the entrance of the racecourse, once on the racecourse the snowmobile must operate under its own power.
3. All participants (including crewmembers entering the start line area, are required to wear eye protection or safety glasses.
4. Snowmobiles must be placed on an approved stand for warm-up and/ or for clearing the track. See CLEANOUT/SAFETY STANDS in this chapter.
5. All snowmobiles on the starting line must have the track and both skis flat on the course surface before starter begins the race.
6. All snowmobiles will be started from a standing position, in a line abreast (unless stated otherwise).
7. The driver's feet must be on the running boards or stirrups. The Race Director may disqualify a driver if the driver's method of start interferes with other contestants.

START

1. On a false start a racer will be penalized by the Chief Starter, Race Director or Flagman, and a penalty if designated will apply.
2. There shall be no change of drivers at any time without notification to the Race Director.
3. Events that take place under natural lighting will be terminated thirty (30) minutes after published sunset. This rule must be strictly enforced. Furthermore, this rule assumes that there are no other visibility issues other than sunset. If visibility is reduced beyond the prescribed limit by other factors, racing must be halted before the prescribed time.
4. Any conditions that reduce visibility (prior to 30 minutes after sunset) must be considered before continuing to race. Other conditions include (but not limited to) snow dust, ice dust, fog, haze, clouds, mist, falling snow, falling rain, and smoke.
5. It is the Race Director's responsibility to discontinue racing if the visibility falls below the prescribed level at any time during the day.
6. An injured or otherwise incapacitated driver or damaged snowmobile shall be prohibited from racing with exception that if in the Race Director's judgement, the driver or snowmobile is determined not to be a danger to driver's self or any other competitor. The Race Director's decision is final.

RACE STARTING PROCEDURES

1. All drivers must be assembled on the starting line, ready to race within two (2) minutes of notification of their race (except special events). This is defined as when the sleds were summoned to leave the pits. The two-minute clock starts when the first sled of the group leaves the pit and enters the racecourse. All the other sleds in the event/heat/final are required to be on the line within the two- minute window.
2. Snowmobiles may be pushed to the entrance of the racecourse, once on the racecourse the snowmobile must operate under its own power.
3. All participants (including crewmembers entering the start line area, are required to wear eye protection or safety glasses.
4. Snowmobiles must be placed on an approved stand for warm-up and/ or for clearing the track. See CLEANOUT/SAFETY STANDS in this chapter.
5. All sleds in the event will need to carry repair tools and supplies on the sled. Additional safety related components may be provided to driver with race director's approval.
6. All snowmobiles on the starting line must have the track and both skis flat on the course surface before starter begins the race.
7. All snowmobiles will be started from a standing position, in a line abreast (unless stated otherwise).
8. The driver's feet must be on the running boards or stirrups. The Race Director may disqualify a driver if the driver's method of start interferes with other contestants.

START

1. On a false start a racer will be penalized by the Chief Starter, Race Director or Flagman, and a penalty if designated will apply.
2. There shall be no change of drivers at any time without notification to the Race Director.
3. Events that take place under natural lighting will be terminated thirty (30) minutes after published sunset. This rule must be strictly enforced.

Furthermore, this rule assumes that there are no other visibility issues other than sunset. If visibility is reduced beyond the prescribed limit by other factors, racing must be halted before the prescribed time.

4. Any conditions that reduce visibility (prior to 30 minutes after sunset) must be considered before continuing to race. Other conditions include (but not limited to) snow dust, ice dust, fog, haze, clouds, mist, falling snow, falling rain, and smoke.
5. It is the Race Director's responsibility to discontinue racing if the visibility falls below the prescribed level at any time during the day.
6. An injured or otherwise incapacitated driver or damaged snowmobile shall be prohibited from racing with exception that if in the Race Director's judgement, the driver or snowmobile is determined not to be a danger to driver's self or any other competitor. The Race Director's decision is final.

RACE RESTART PROCEDURE

1. The Race Director may have a restart at his discretion. Race Director's decision is final.
2. In the event of an accident involving one (1) or more snowmobiles, the Tech Director may at his sole discretion rule said snowmobile(s) mechanically unsafe to participate in the restart.
3. All snowmobiles will be stopped under the red flag. The flagman will notify drivers when to move snowmobiles and he will have them proceed slowly to the point of restart. If only one (1) lap, or less, has been raced, the order of snowmobiles for the restart will be the same as the beginning of the race with the following exceptions:
 - a. Any snowmobile causing the stop of a race and a subsequent restart will be placed to the rear of the restart sequence.
 - b. Any snowmobile unable to immediately return to the starting line will be placed to the rear of the restart sequence.
 - c. After more than one (1) lap has been raced, the restart position of the snowmobiles reverts to the last officially counted lap.
 - d. Snowmobiles will be restarted in a staggered line.
3. With the Race Director's permission, only one (1) crewmember (per snowmobile) will be allowed on the track in the event the competitor cannot start his/her snowmobile alone. No mechanical work can be performed by the crew member. He may assist the driver in starting the sled, by pulling the recoil device/rope, controlling throttle, applying choke/enrichener, or alternate fuel delivery squirt bottle, removing the hood, securing hood, and tether switch, handing safety and personal equipment to driver.
4. Drivers and snowmobiles must be on the starting line within two (2) minutes of restart notification.
5. (Oval Sprint) Under Red Flag conditions up to 3 pit crew members per sled are allowed on track to add slide lube and perform engine and radiator cooling functions to the sled.
6. Upon be summoned to restart, all crew members shall leave the track surface except the designated crew member who assists in the engine starting procedure with the driver.

LEAVING THE COURSE

1. Drivers should stay on the confines of the marked course. At the discretion of the Race Director, a driver may be disqualified for leaving the confines of the course.
2. Drivers may not stop on the racecourse. If mechanical problems or other factors require stopping, driver will comply with rules for the specific event as prescribed by the officials before the event.

CONTROL OF SNOWMOBILE DURING RACE

1. It is expressly forbidden to drive or push a snowmobile in a direction other than that of normal race traffic. A driver who has spun out is permitted to turn snowmobile around to continue the event provided such action is taken only when the course is clear.

BLOCKING AND FOOLISH DRIVING

1. The deliberate blocking of a faster snowmobile is cause for disqualification at the discretion of the Race Director.
2. Bumping or cutting of lanes is cause for penalty or disqualification at the discretion of the Race Director. Any dangerous or foolish driving, bumping, chopping, or unsportsmanlike conduct on the course, in the pit area, or anywhere else on the race grounds will subject contestant to disqualification at the discretion of the Race Director.

OBSTRUCTION

1. If for any reason a driver is forced to stop on or near the course during an event, it would be the driver's first duty to remove the snowmobile from the track so as not to endanger or obstruct other drivers.

RACE FINISH

1. The finish line will be clearly marked.
2. A driver whose snowmobile is disabled before driver reaches the finish line may be pushed or pulled by driver's own unaided muscular energy across the finish line and will be considered to have completed the race. A competitor is said to have finished the race when driver is in contact with the snowmobile and any part of the snowmobile crosses the finish line.
3. All laps must be completed by first (1st) place snowmobile to declare a finish. All competitors will be given a finish position per number of laps completed. Any drivers that do not complete the checkered flag lap will be scored in order of finish and laps completed. Appropriate points and prize money will be awarded based upon published formulas.

SIGNALS

1. A driver who has spun off or stalled must raise both hands over driver's head to indicate that no more movement will be made until the field has passed and to indicate no injury.

DRIVERS BRIEFING

1. The mandatory meeting (or meetings) will be held at an announced time and place. It will be conducted by the Race Director and Race Promoter. Descriptions of the course, flags, etc. will be made. An interpreter should be used when needed. Pins, stamps, tags, roll call, random call, etc. may be used to check the identity of drivers at the briefing.

RADIOS

1. There will be no independent radio transmission on sanctioning body's radio frequency.
2. Unless otherwise stated, radio communication between crew and driver not allowed while driver is on the course. Drivers will always use an operational race-ceiver during competition. Race Ceiver communication from the race control official has the same authority as the race director and shall not be challenged.

CLEAN OUT / SAFETY STANDS

1. Snowmobile safety stands that catch and retain track, track lugs, traction components and other items that are thrown by a track are mandatory (see illustration).

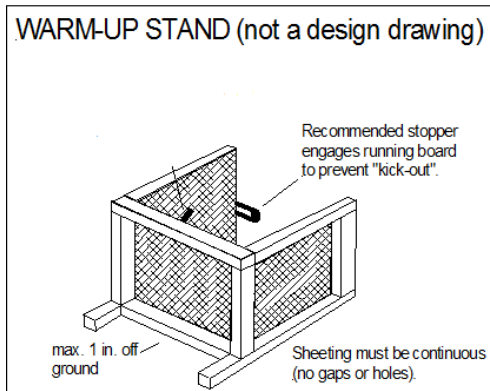

2. The stand must be no more than six (6) inches from the rear of the tunnel opening and no more than twelve (12) inches from the track. The safety stand will be constructed of metal equivalent to 6061/T6 aluminum, 1/8 inch thick. Side panels are mandatory, and they must extend at least to the center of the rear axle. Vertical coverage must be no more than one (1) inch off the ground/ice and as high as the snowmobile support device. Coverage must be continuous (no lightening holes). A plywood liner is recommended to help absorb impact. Safety stand must maintain enough height to prevent track encountering ground/ice surface. The stand must be used whenever the rear of a snowmobile is raised to clean out the engine or track.
3. No full throttle operation while snowmobile is on warm up stand.

MISUSE OF PIT PASSES

1. Improper usage of pit or paddock passes will be grounds for discipline.

FIRE EXTINGUISHER

1. Fire extinguishers must be available in pit, paddock/staging and starting line areas. Fire extinguisher minimum size will be five (5) pounds with ABC fire extinguishing capabilities. Fire extinguishers will be in place before the start of the race. All trailers, haulers, enclosed truck bodies, etc. used for transport of racing sleds and their support equipment must have 2 (two)-5-pound ABC extinguishers on board, accessible and serviceable always.

GENERAL SNOWMOBILE RULES

These **GENERAL RULES** apply to all snowmobiles in competition unless so noted. All participants, racers and crewmembers are required to be fully aware of these regulations and must abide by them.

Participants are solely responsible for the condition of their snowmobiles and their competence to operate them.

Where the rules permit or require components or equipment to be installed, replaced, altered, modified, or fabricated, it is the sole responsibility of the driver to select components, materials and/or fabricate the same so that the components will perform safely in competition.

CLASS ELIGIBILITY & SNOWMOBILE ID

1. Unless otherwise specified in specific ISR rules, a snowmobile used in more than one class or division must comply with all rules and safety guidelines for each class or division in which it competes.
2. In stock and stock-based classes, the chassis and engine must have been originally OEM assembled and serial numbered indicating that the

snowmobile is a stock qualified unit from the production run of a stock qualified model.

- All snowmobiles in Modified classes must have serial numbers permanently affixed to the engine and the frame. Duplication of serial numbers is not allowed.
- If the tunnel, engine, or other serial numbered part is replaced, the serial number must be removed from the replaced part and affixed to the new part.

ENGINE

- ISR and/or the Race Rules Committees will approve the validity of all engine intake systems.
- In stock and stock-based classes, the engine must have originated from a stock qualified, OEM produced snowmobile.
- In stock and stock-based classes, coolant thermostats, regardless of location in the cooling system, may be ran as produced, changed to alternate temperature settings, or completely removed. If removed a control plate/washer to control volume of flow may be installed in its place. This plate shall serve no other function than restricting the flow of coolant.
- In Stock classes, the OEM for the model exhaust system must remain as produced by the manufacturer and must be fully functional. In Mod classes it will be specifically noted as to which exhaust components may be changed or modified.
- In all two cycle engine classes with individual chamber exhaust for each cylinder, the following minimum standards for straight-thru silencers are required:

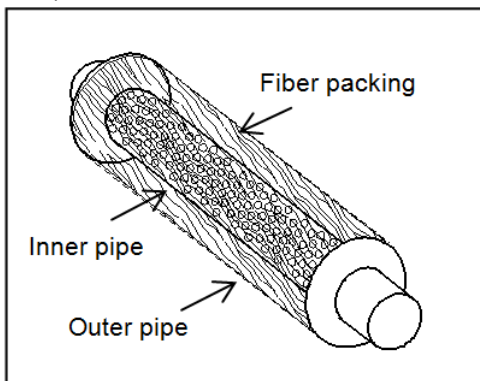

- Inner pipe must have at least 15 holes per square inch. Minimum hole size 1/16 in. (Minimum 3/8 in. sound absorbing material around the entire circumference of inner pipe).
- Inner pipe (perforated core) must contact sound absorbing material (fiber or steel wool packing).
- Outer pipe must be at least 3/4 in. larger than inner pipe.
- Minimum silencer length 3 in.

- OEM carburetor slide valves and replacement jet components without modification will be allowed in all Stock classes. No modification to carburetor body will be allowed.
- An adequate return spring on the throttle is required. The throttle must be a direct mechanical thumb mechanism, which must be located on the rear side (toward the rear of the snowmobile) of the right-hand handlebar. Throttle must be thumb operated. Twist grip throttles not allowed.
- All Stock classes - Choke control devices may be disconnected; however, they may not be removed from their mounting location.

DRIVE

- Brakes shall always be operative. Brake lever must remain on the left, front side of handlebar.
- The master cylinder, caliper and disk assembly must be commercially available.
- In Modified classes, anytime the brake assembly has been modified or relocated, the brake disk must be covered with a shield capable of retaining an accidental explosion.
- The disk pad contact surface area may not be reduced more than 15% of the original pad contact surface area.
- Chains, pulleys, and exposed moving parts will be isolated from the driver and other competitors by shields capable of retaining all accidental explosions and component impacts. Integrity of protective shields shall be at the Race and/or Tech Director's discretion. No holes may be drilled in protective shields.
- Unless otherwise specified, stock class belt guards are acceptable in Stock classes only.
- Secondary clutch windage plates may be removed in all classes.
- Custom clutch guards, clutch guards on purpose-built chassis, and specialty chassis may use Carbon fiber, Kevlar, and other materials as reinforcement of standard clutch guard material and design. Newly designed clutch guards must exceed the specifications and limits established in standard clutch guard requirements, See specific disciplines for details. Each specific clutch guard must be submitted to ISR with digital pictures (both installed and uninstalled, at least four views) and a detailed explanation of design, design limitations, and method and type of fasteners used to affix the guard to the chassis. ISR may request an appointment to inspect on site.

SKI SUSPENSION AND STEERING

1. Handlebar extensions are allowed. They must conform to the illustration below.

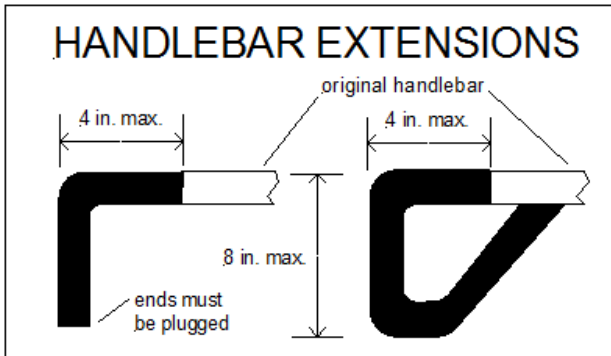

2. All handlebar ends must be plugged.
3. Only steel suspension springs allowed unless otherwise specified.
4. In any oval class minimum suspension travel is functional travel.

SKIS & SKI RUNNERS

1. Except where otherwise specified, one cutting edge (steering edge) allowed per ski on snowmobiles with independent front suspension. Any ski edge with over 1/2-inch turndown constitutes a cutting edge
2. A maximum of fourteen (14) inches total length of carbide per ski is allowed. (Unless otherwise specified in specific classes).
3. All ski loops must be at least one (1) inch wide and 5/8-inch-thick or 1-inch diameter round material. The arc of the leading edge of the ski loop must have an outside radius of at least 2 1/8 inches and extend at least 120 degrees upward (see illustration). Plastic ski loops must be affixed with steel bolts.

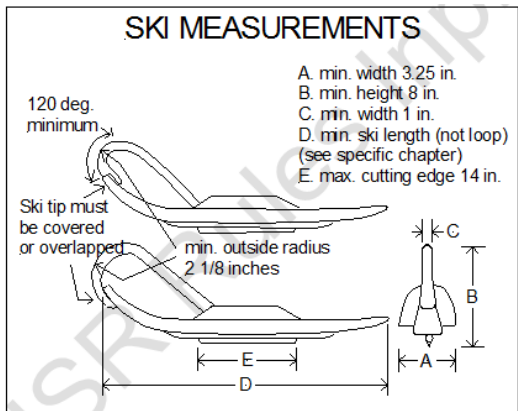

The ski loop must overlap the end of the ski and secure to the underside or it must cover the leading edge of the ski entirely. Exceptions may be noted in class specifics.

4. Metal ski loops must be affixed with steel bolts and not welded (Oval-minimum two fasteners).
5. Metal ski loops must have adequate lateral or vertical support bracing to prevent ski tip loops from dislodging or breaking off.
6. Ski tip (not including the loop) must be turned up 1.5 inch from the bottom of the ski (not including the keel(s) or ski runner).
7. No part of the ski may contact the body or suspension through the ski's normal range of travel and/or movement.
8. Ski loop failure of any type is grounds for disqualification.

TRACK SUSPENSION

1. Any OEM type slide rail hyfax may be used as a replacement.
2. Slide rail hyfax can be drilled in all classes.
3. Where allowed in these rules and by local environmental laws, slide rail lubrication systems may be used. No lubrication medium will be allowed that hampers competitor's visibility. No toxic solutions may be used.
4. Only steel suspension springs allowed unless otherwise specified.
5. At safety inspection, track suspension travel will be measured vertically at the rear bumper, two inches of travel must be noted with a max 150 pounds of weight displacement.

TRACK AND TRACTION

1. Track dimension rules are specified in each chapter. A 1/8-inch maximum variance in the minimum track width requirement is allowed. No cutting, notching, or trimming of the track is allowed, this is class and discipline specific, and is not allowed unless preceded by an ISR Competition bulletin.
2. Unless otherwise indicated, the track must be centered on the centerline of the tunnel in all modified classes. Modified classes are allowed track offset for installation of brake assembly on front driveshaft. In no case may this offset be more than 2 (two) inches, determined from edge of track to inner edge (side) of tunnel. In Stock and Stock-based classes, the track location must be as produced unless otherwise specified.
3. In all forms and classes of racing, track clips and guide clips may be replaced when worn - guide clips may be removed and replaced with track clips - track clips may be removed and replaced with guide clips - the track must retain the original number of clips with which it was produced.
4. In all forms of racing, there are traction device limitations, see specific chapters for details (see Appendix for traction device measurement details).
5. Identification numbers affixed or molded into tracks by the molder of the track must remain completely visible and unmodified. No traction device or other item may be installed over the identification numbers on the track. Identification numbers include model number, serial number and/or any other information applied to the track by the molder.
6. Tracks may not be reversed.

FRAME AND BODY

1. A rear snow flap of sufficient material must be installed in a permanent manner and shall be held down (restrained from rearward movement) to restrain traction components, snow, mud, rocks, and other material thrown from the track at all speeds. Recommended materials are 3/16-inch fiber reinforced rubber belting or 3/16-inch semi-rigid plastic such as HD polyethylene or UHMW polyethylene.
2. The snow flap must overlap the widest part of the rear tunnel opening by at least one inch on each side.
3. The rearward movement of the snow flap must be restrained with steel cable (or similar material) to the frame of the snowmobile.
4. The snow flap must be in contact with the course surface when the rider is on the snowmobile. Violation of this rule results in mandatory expulsion from the class.
5. The snow flap on the twin track snowmobile must be reinforced to keep it in proper placement at racing speeds.
6. The maximum overall snowmobile width is 45 inches unless otherwise stated.
7. All modified snowmobiles regardless of class or discipline will be equipped with an upholstered, padded seat minimum thickness one (1) inch, minimum length fifteen (15) inches. OEM seats may be cut down to the design needs of the builder but must meet these minimum standards.
8. Unless otherwise stated, seats in Stock class must be OEM for the model. OEM seats have no requirements for fabric, padding, dimension, or coverage. If the seat meets manufacturers legal design criteria it is legal for any class, stock or modified.
9. Unless otherwise specified, tunnel protective strips may be added to underside of tunnel to protect the tunnel and cooling system from being damaged by traction products.
10. Snowmobiles used in competition may be painted any color with the following exception, in ovals orange or international orange may not be used.

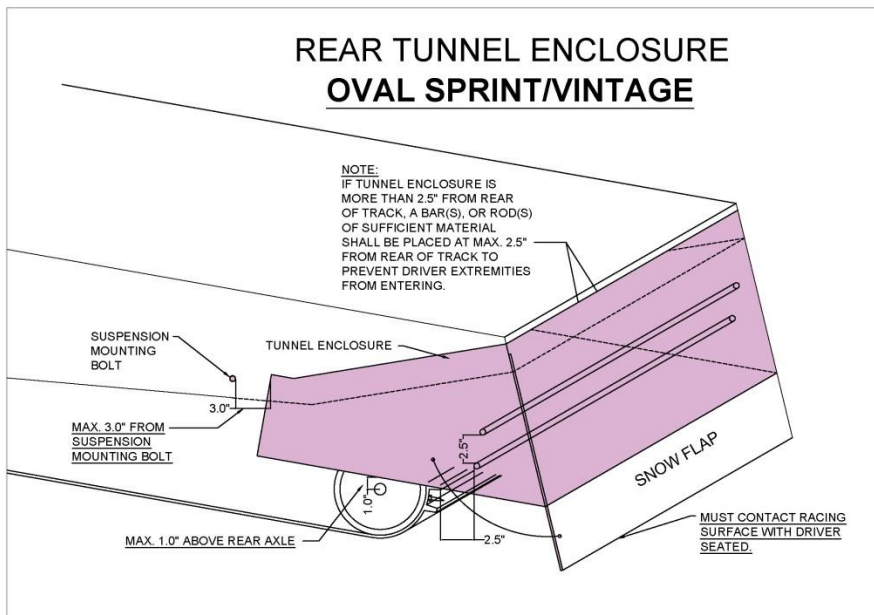

11. Custom clutch guards, clutch guards on purpose-built chassis, and specialty chassis may use Carbon fiber, Kevlar, and other materials as reinforcement of standard clutch guard material and design. Newly designed clutch guards must exceed the specifications and limits established in standard clutch guard requirements. See specific disciplines for details. Each specific clutch guard must be submitted to the affiliate and ISR for determination. ISR with digital pictures (both installed and uninstalled, at least four views) and a detailed explanation of design, design limitations, and method and type of fasteners used to affix the guard to the chassis. ISR may request an appointment to inspect on site. Composite materials may be used only when specified.

12. (All snowmobiles in all classes) The rear of the tunnel must be enclosed with steel or aluminum comparable in strength to the tunnel material. The tunnel enclosure is required to

reduce the possibility of skis and driver's extremities entering the tunnel area. The shaded area (see illustration) must be enclosed. The enclosure shall cover the rear and both sides and extend forward to the rear suspension mounting bolt. The bottom of the enclosure shall be no higher than one (1) inch above the center of the rear axle (with the driver in place). The rear of the enclosure shall be no further than 2.5 inches from the rear of the track. The tunnel enclosure must be securely welded, bolted, or riveted to the tunnel.

13. Stirrups or foot pegs of rigid material allowed. The dimensions of the foot stirrup must not exceed the maximum width of the right-hand side of the hood nor the maximum height of the right-hand side of the hood. (Not including bumpers, skis, trim, etc.). Stirrups or pegs may be padded.

IGNITION & ELECTRICAL

1. All snowmobiles must be equipped with a tether switch that must always be securely attached to the operator and be operable. The switch must "kill" the engine by disconnecting the ignition system when the operator and the snowmobile become separated. It is the responsibility of the driver to make certain that the tether is attached to everyone who starts the engine or operates the snowmobile.
2. Maximum tether cord length will be 4 feet except where noted otherwise. Verification of tether cord length will be determined at tether cord's fully extended length.
3. The tether cord will be securely fastened to the driver. D rings/tabs on gloves and jackets are not designed for the abuse encountered during competition and accidents. Please have your tether cord mounting location on your body in a securely constructed area. A race or tech director may disapprove of the attachment method at any time. Drivers will not be allowed to compete until the attachment situation is rectified.

4. The tether switch will be securely mounted in a location on the snowmobile other than on the handlebars or steering column.
5. Wet cell if used must be enclosed in a non-conductive battery box. Positive terminal must be shielded. Battery box must be securely held in place. Solid core or gel cell batteries need not be cased.
6. Unless otherwise specified, electric start parts including motor, solenoid, battery, battery bracket, wiring, and ring gear may be removed. No machining, cutting, or grinding allowed for removal.
7. Taillights must always be displayed when on the racing surface whether the engine is running or not. Taillights must always be red in color. It is strongly suggested that the taillight be OEM snowmobile lights due to the design factors involved in OEM regulations for reflectivity and brightness.
8. Running lights or number illumination boards may be used. Running lights must conform to all electrical safety rules and must be "switched" so that they can be turned off if required.

FUEL REGULATIONS

NOTICE: It is advisable for all competitors to have their fuel tested at the event, before competing.

1. A contestant appealing a fuel disqualification must bear the expense of the fuel analysis and handling.
2. Allowed gasoline and lubricants:
 - a. Only a commercially available pump gasoline that complies with these rules is allowed. (The term "pump gasoline" includes fuels dispensed from service station pumps and racing fuels that are commercially available in fuel cans and drums.) The gasoline may be mixed with petroleum, vegetable, or synthetic based lubricants. The use of oils, fuels (including gasohol), and additives that provide power-boosting characteristics are forbidden.
 - b. Only motor fuel compounded of standard pump gasoline and an acceptable lubricant are allowed. Additives that produce power more than that produced by standard pump gasoline and petroleum base oil shall not be permitted. The list of unacceptable additives includes, but is not limited to, alcohol, nitrates, and other oxygen bearing compounds.
 - c. No competitor or driver's pit personnel shall possess power boosting additives or agents upon the race premises of the sanctioned event. Violations of this rule shall subject the violator to severe disciplinary procedure.
 - d. Aerosol cans of ether are allowed at sanctioned races for starting purposes. No driver will be allowed to carry such cans on their person or their snowmobiles during the race.
 - e. Driver statements as to their fuel components will be binding and may be verified by various fuel tests. Drivers must allow officials to test their fuel at any time.
 - f. Youth Oval Racing classes, commercially available gasoline that is reformulated with up to 10% ethanol is allowed, the exception being "Big Track" competition for 120, 206 and 200 base class sleds. 120/206/200 and all oval junior classes must use legal fuels containing no ethanol.

FUEL TESTS

WARNING: Gasoline, lubricants, additives, and fuel test reagents are all potentially hazardous materials. Anyone handling them should be aware of the hazards and act accordingly. Race Rules Committees and ISR establish these guidelines and recommended test procedures, but do not assume liability for injury or death caused by the handling of these materials.

Any or all these tests may be employed. Test results may be confirmed from time to time using an infrared spectrometer.

IF ANY OF THESE FIELD TEST ARE FAILED BY A PARTICIPANT HE WILL BE DQ'ED FROM ALL CLASSES THAT HE PARTICIPATED IN FOR THAT DAY.

1. ELECTRICAL CONDUCTIVITY (DI ELECTRIC CONTENT)
2. CERIC NITRATE REAGENT TESTING
3. REAGENT D TEST FOR DIOXANE
4. WATER SOLUBILITY TESTING
5. ANY OTHER TEST APPROVED BY RACE RULES COMMITTEES

ENFORCEMENT, DISCIPLINE AND VIOLATIONS

All participants are subject to disciplinary action for violations of these rules in accordance with the sanctioning organization's bylaws. Penalties may include suspensions, fines, loss of points, disqualifications, or any combination thereof. The nature of the penalty is determined by the gravity of the offense and its effect on the safety and good reputation of snowmobile racing. The violations hereinafter set forth are subject to the penalties noted.

EJECTION FROM RACE SITE

1. The Race Director has the right to eject any person(s) from the pit, paddock (staging area) or racetrack area.

CONDUCT OF PARTICIPANT (OFFICIALS, DRIVERS, CREWS, ETC.)

1. Participants are solely responsible for the condition of their snowmobiles and their competence to operate them.
2. No driver may, at any time, ride/drive in such a manner as to endanger life or limb of other riders, officials, or the public.
3. Vulgarity, derogatory or offensive language will result in disciplinary action, ejection from race site and be subject to fines and penalties.
4. Any participant that threatens bodily harm or assaults any official, driver, crew, etc. will be subject to disciplinary action, ejection from race site and be subject to fines and penalties.
5. Clothing displaying vulgar language is not allowed.

DRIVER LIABILITY RELEASE COVENANT NOT TO SUE

1. *The driver/pit crew, in filing an application to enter the event, elects to use the course of the event at driver's /pit crews own risk, and thereby releases the sanctioning organization together with their heirs, assigns, officers, representatives, agents, tech personal, employees, and members, sponsoring organization and owners of properties on which sanctioned events are to be held from all liability from injury to person, property and/or reputation from tech decisions that may be received by said entrant and from all claims of said injuries to the parties listed above growing out of, or caused by any construction or condition of the course over which the event is held and or piece of equipment that participant entered into competition.*
2. *Drivers/pit crew and other participants further acknowledge and fully understand that there may also be other risks that are not known or foreseeable at this time, and the above and released persons cannot control these risks, nor have the released persons judged the participants' skill level or ability prior to allowing the participants to participate and consequently is not in a position to guarantee the participants' personal health or safety during the programs, events or activities. DRIVER/PIT CREW KNOWINGLY AND VOLUNTARILY ASSUMES ALL SUCH RISKS, BOTH KNOWN AND UNKNOWN, ANTICIPATED AND UNANTICIPATED, EVEN IF ARISING FROM THE NEGLIGENCE OF THE RELEASED PERSONS OR OTHERS, AND THE PARTICIPANTS ASSUME FULL RESPONSIBILITY AND LIABILITY FOR THE PARTICIPANTS' PARTICIPATION.*
3. *In consideration of permission and as a requirement of participation in sanctioned events, drivers, pit crew and other participates hereby covenant and agree not to sue the sanctioning organization, or its heirs, assigns, officers, representatives, agents, employees, and members, sponsoring organization and owners of properties on which sanctioned events are to be held, and further agree to fully release, indemnify and hold harmless those persons from any and all causes of action, demands, claims, and loss of injury to person or property or damages, of any nature whatsoever, whether the participation is supervised, unsupervised, however the injury is caused, including, but not limited to the negligence of any released persons.*

DRIVER RESPONSIBILITY

1. The driver has the responsibility for the actions of his crew. It is the driver's responsibility to see that all crewmembers are aware and abide by all rules and guidelines.
2. The condition of a snowmobile is the responsibility of the driver. A driver may be disciplined if driver's snowmobile is modified to defraud the officials or other competitors.

FRAUD, BRIBERY & ILLEGAL ASSISTANCE

1. In addition to non-compliance with any of the above regulations or rules, the following offenses shall be considered a breach of regulations subject to disqualification.
 - a. Bribing or attempting to bribe anyone connected with the race or accepting or offering to accept a bribe.
 - b. Competitor accepting any kind of assistance that aids in snowmobile operation during the race.
 - c. Any fraudulent proceedings or act of prejudicing the interest of the race.

INTOXICATING BEVERAGES & DRUGS

1. Drinking of intoxicating beverages is forbidden by any participant. Anyone showing evidence of having used an intoxicating beverage must leave the premises (specifically pit, paddock (staging area), warm up area, tear down and racetrack) immediately and be subject to disciplinary action by the disciplinary committee. This shall be in effect through the final inspection of snowmobiles.
2. Possession or use of illegal drugs or drug substances, as defined below, is prohibited in any form, by any participant, on the race facility, or in any area considered to be used in the operation of the race facility, such as parking lots or leased properties.
3. Illegal drugs are these substances defined and prohibited by state/provincial and/or federal law.
4. Any person found to be in possession or under the influence of an illegal drug or drug substance on race facility property, as defined above, or any person who is arrested by duly constituted authorities and charged with possession and/or use of illegal drugs or drug substance or any person who is formally charged by a court of law with illegal drug violations, shall be subject to suspension from competition and eviction from the race facility, and denial of further entry to the race facility for a period determined by the disciplinary committee.
5. Any participant who is formally charged by a court of law with an illegal drug violation, upon notification to the ISR Advisory Board, shall be suspended from all forms of participation at any ISR event until such time as the charges are fully adjudicated through the legal process. Any conviction of a formal drug charge by such will be prohibited from taking part in any ISR or affiliated event for a minimum period of three (3) years from date of conviction.
6. Any participant suspended for violation of these rules may be granted an appeal hearing by a board of officials designated by the ISR Advisory Board, provided the suspended participant requests such hearing in writing, within fourteen (14) calendar days of the date of suspension. It is the responsibility of the suspended party to make such a request if a hearing is desired.
7. The cost of convening the board of officials will be borne by the participant prior to the convening of the board.
8. A participant suspended for violation of these rules, EXCEPT IN THE CASE OF PERSONS CHARGED WITH SELLING DRUGS, may, as the result of a decision reached through the hearing process detailed above, be reinstated, if it is mutually agreed that the participant (at his own expense) will produce documentation from a physician licensed within the state or province, certifying that he or she is drug independent, as a result of random and periodical examinations and urinalysis testing made at the request of the ISR Advisory Board.
9. If a participant is using prescription drugs on advice of a physician, such use must be reported to the Race Director prior to the participant's entry into any ISR activities. Failure to notify will subject the participant to penalties as prescribed above.
10. A participant is any person taking part in any event sanctioned by or affiliated with International Snowmobile Racing, Inc., in any form, including but not restricted to drivers, snowmobile owners, mechanics, crew members, sponsors, track officials, pit area personnel, manufacturers and press representatives. All such persons shall be considered public figures that have by their own choice become involved in the snowmobile racing events, with the full understanding that he or she must abide by the rules and regulations established and published by ISR. All participants are responsible for their personal conduct.

RACE DIRECTOR AUTHORITY

1. The Race Director and Technical Director will be certified by the sanctioning organization.
2. The Race Director shall be responsible for the conduct of the race. He shall have the right to make the final determination concerning all aspects of the race and the race facility, including design (these rules and regulations notwithstanding). The Race Director is defined as the overseer/controller of the actual track operations during an event. He has prevue over all aspects of the race and interpreting rules that are applied. He may be a track owner/ or contract manager of a facility, however, "Race Directors" that are of administrative or business side of the event, although they may be referred to as race directors are not the on-track event director. In any case ISR certification is required.
3. He shall have the voice of authority to discipline the participants for violation of the rules. Such discipline will be limited to disqualification of a participant and/or exclusion from an event.
4. Official race results shall be approved by the assigned Race Director and a signed copy will be returned to the promoter for announcement and distribution.
5. Race Director may not have vested interest in the outcome of an event over which he/she officiates. He/she may not officiate over a class in which he/she has a vested interest.
6. Race Directors may compete in events other than those in which they officiate.
7. The Race Director may cancel any race or the complete event for reasons of safety regarding competitors or spectators, and in such case shall determine the awards, if any. The Race Director may shorten the race for any reasons of safety but must give drivers adequate notice in advance.
8. A Race Director may judge the mechanical integrity of all timing equipment.
9. Only Drivers (no other participants) will have discussions with the Race Director about protests, and driving complaints, etc., and may approach the Director before the day's events, after an event, or at the direction of the Race Director.
10. The Race Director has the authority to judge the racing abilities of competitors and take appropriate action to ensure the safety of the event.
11. The Race/Tech director shall have the authority to determine structural integrity.
12. The Technical Director shall carry and be responsible for the official specifications and certain instruments for measurements concerning verification and control of contestants' snowmobiles. The Technical Director may not officiate over a class in which he has a vested interest.
13. Technical equipment and specifications will not be used for any purpose other than the conduct of the sanctioned event.
14. Decisions of the Race/Tech Director may be reviewed by the board of the sanctioning body.
15. Decisions made at an event shall not be overturned without a formal appeal. Notice of the appeal process shall be given and a suitable period for all parties to prepare must be allowed.

NO EXPRESS OR IMPLIED WARRANTY OF SAFETY SHALL RESULT FROM PUBLICATION OF OR COMPLIANCE WITH THE RULES AND REGULATIONS IN THIS PUBLICATION. THEY ARE INTENDED AS A GUIDE FOR THE CONDUCT OF THE SPORT AND ARE IN NO WAY A GUARANTEE AGAINST INJURY OR DEATH TO SPECTATORS OR PARTICIPANTS.

VINTAGE OVAL COMPETITION

The intent of these classes is to establish races in which all can compete at their level of personal and equipment ability. The class structure is organized in such a way as to enable as many snowmobiles as possible a place to successfully compete.

VINTAGE OVAL DIVISIONS

STOCK
PURE STOCK IFS
SUPER STOCK
RELIC MOD
SPORT MOD
MOD STOCK
SUPER MOD
PRO MOD '74 AND OLDER
IFS SNO – PRO

GENERAL SNOWMOBILE REQUIREMENTS

All snowmobiles in all classes must conform to all applicable rules in the ISR GENERAL RULES AND REGULATIONS section unless otherwise specified here.

DRIVE

1. (Mandatory in all classes except Stock and Super Stock where it is recommended.) The clutch cover must conform to the rule for Modified Oval Sprint classes.

GENERAL SNOWMOBILE REQUIREMENTS

These following rules apply to all sleds in OVAL SPRINT COMPETITION and VINTAGE OVAL COMPETITION.

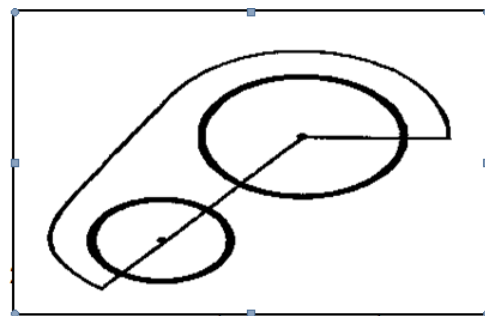
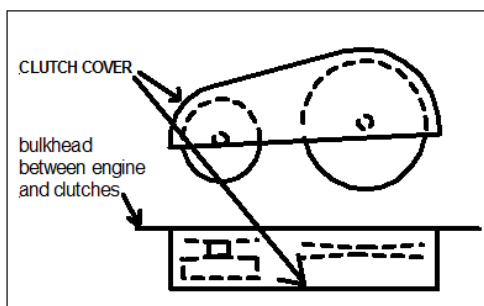

DRIVE

1. (Mandatory in all classes except Stock/Super Stock where it is recommended.) The clutch cover must be separate of cowl configuration and cover clutches down to center of clutch bolt or below. Must be .060 inch, 6061T6 aluminum or equivalent steel material and be covered with 6-inch-wide belting. Snowmobile with removable side panels may bolt clutch cover to side panel to meet this requirement. See illustration.

The following illustration provides the criteria for proper clutch cover design for modern style chassis with driven clutches mounted in higher centerlines than previous designs. Modern style chassis are required to comply to this format of coverage. (Side view shown)

2. Custom clutch guards, clutch guards on purpose-built chassis, and specialty chassis may use Carbon fiber, Kevlar, and other materials as reinforcement of standard clutch guard material and design. Newly designed clutch guards must exceed the specifications and limits established in standard clutch guard requirements, See specific disciplines for details. Each specific clutch guard must be submitted to ISR with digital pictures (both installed and uninstalled, at least four views) and a detailed explanation of design, design limitations, and method and type of fasteners used to affix the guard to the chassis. ISR may request an appointment to inspect on site.

3. **CLARIFICATION:** In the above drawings, access holes for clutch bolt/fastener and driven clutch/torque converter fastener in the clutch cover/clutch guard is allowed. The access hole if surrounded by the cover can be no larger than 1.250 diameter in either the drive or driven clutch cover. In the case of clutch guards that are legal in design to the centerline of the bolt/fastener, the upper radius of the 1.250 diameter hole is allowed. (One half the diameter or a 1.250 hole.)



BELT GUARD WITH TOE PROTECTION DEVICE

It is advisable that in construction of this guard, considerations are made to protect the driver's foot in the case of belt failure. A method of belt containment and preventing it from entering the foot-well area must be made. Determination by technical inspector is final and not subject to appeal. (Example of toe protection, other designs and methods may be used at discretion of the builder.)

SKI SUSPENSION AND STEERING

1. Leaf Spring Snowmobiles must have functional steel leaf springs.
2. Springs must be steel or OEM-for-the-model if some other material.
3. IN ALL CLASSES: Offset ski stance not allowed unless produced by the OEM for the model.
4. All ISF snowmobiles a functional ski suspension is required.
5. Carbide (one (1) cutting edge) plus one (1) additional edge may extend no more than 5/8 inch from the lowest surface of the ski. Only one (1) cutting edge ski is permitted on independent front suspension snowmobiles. Any ski edge with over 1/2-inch turndown constitutes a legal keel cutting edge. The ski runner, carbide edge or wear bar may be altered to a single plane angle of not less than sixty (60) degrees inside included angle. The carbide insert must be centered in the host bar.
6. Any commercially available skis and ski runner(s) that conform to these rules are allowed.

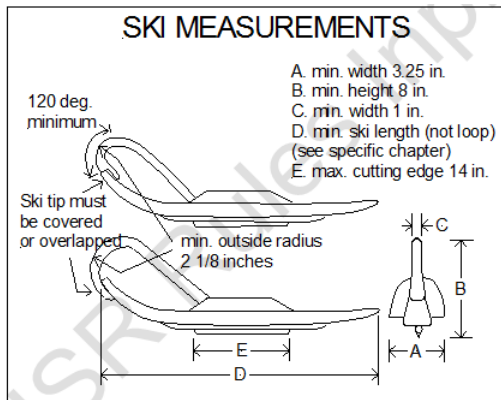

TRACK SUSPENSION

1. All IFS snowmobiles must have a functional rear suspension required.
2. Springs must be steel or OEM-for-the-model if other material.

TRACK AND TRACTION

1. No cleated tracks allowed.
2. Traction devices must conform to Oval Sprint rules. (No titanium studs allowed. No carbon fiber stud backing plates allowed.)

FRAME AND BODY

1. Engine, chassis, and component ID numbers should be maintained if possible.
2. Maximum overall width of any snowmobile is 45 inches (outside of skis or body, whichever is wider).
3. Right hand foot stirrups/footrests/ may not extend past the centerline of carbide. Maximum height of any footrest, stirrup, or hoop is 17 inches from the upper surface of the running board to the top, (vertical max height) of the footrest assembly.

IGNITION AND ELECTRICAL

1. Programmable ignition systems allowed in all classes. Ignition reprogramming is not allowed in the staging area or on the racetrack.
2. Any OEM production taillight, with the brake element on whenever the engine is running is mandatory.

STOCK / PVR PURE STOCK [Click Here](#)

In stock and stock-based classes, no change or modification is allowed unless specifically allowed by these rules. If these rules do not specifically allow a change or modification, then it must be assumed that the change or modification is not allowed.

1. Any stock qualified, LEAF SPRING MODEL 1985 or older is eligible. No limited production or race only models (such as '76 and '77 Yamaha SRX, Mercury Snow Twister, Ski Doo Blizzard, Arctic Cat Z OR EXT).
2. Entries will be segregated into classes based upon engine cooling (i.e., Fan, Free-air, Liquid).

GENERAL COMPETITION RULES

SUGGESTED CLASSES

STOCK 250	264cc maximum
STOCK 300	317cc maximum
STOCK 340	358cc maximum
STOCK 440	464cc maximum
STOCK 650	680cc maximum
STOCK 800	836cc maximum

ENGINE

1. The engine must be OEM-for-the-model and year.
2. Engine, engine mounts and exhaust must remain in original OEM-for-the-model locations (of the chassis).
3. Any internal modifications allowed to the engine.
4. No external modifications allowed. Engine must maintain OEM-for-the-model appearance.
5. Engine bore size may be increased up to class limit (see above).
6. Aftermarket pistons allowed.
7. Intake concept (for the engine) must be maintained (i.e., piston port, reed valve, etc.)
8. Any round slide carburetor from a stock qualified snowmobile is allowed. Flat slide carburetors not allowed. Air intake silencers (air boxes) may be removed.
9. Cooling system concept (for the engine) must be maintained and fully functioning (i.e., free-air, fan, etc.).
10. Must be naturally aspirated.
11. OEM-for-the-model exhaust system must be used.
12. The only legal ignitions will be OEM 1985 and older. All ignitions must be derived from a stock qualified model 1985 and older, or a designated aftermarket replacement of the original component.
13. Programmable ignitions are not allowed.

DRIVE

1. Any snowmobile brand OEM primary clutch allowed.
2. Secondary clutch must be OEM-for-the-model chassis.
3. Chain case must be OEM. For model and year.
4. Chain case may be moved up to two inches.
5. Any track drive shaft and track drive sprockets may be used.
6. Track drive shaft may be relocated a maximum distance of 2 inches.
7. For chassis without jackshaft, a jackshaft may not be added.
8. Jackshaft models must use OEM for the model jackshaft.
9. Brake components may be replaced. Must be commercially available and not modified.

SKI SUSPENSION AND STEERING

1. Skis must be OEM-for-the-model and year or an exact aftermarket replacement.
2. Leaf springs must be steel and functional.
3. Ski spreaders allowed. Maximum increase 3 inches (each ski).
4. Only oil filled shocks can be used on the skis. Shocks must mount in original position. (No Gas Shocks)
5. Spindles must be enclosed.
6. No Cobra skis allowed.
7. Steering column must be OEM-for-the-model chassis. The handlebars and/or handlebar mounting bracket may be replaced.
8. Any commercially available handlebar allowed.

TRACK SUSPENSION

1. Any track suspension from a stock qualified, 1985 or older model is allowed. Suspension must be used with no modification allowed. Marginal snow wheels can be added or deleted.
2. Remote Adjusters are not allowed

TRACK AND TRACTION

1. Any commercially available one-piece molded rubber track allowed. Track must fit within the confines of the tunnel without modification to track,
2. The track must be used as produced by the molder of the track. No cutting or other modifications allowed.

FRAME AND BODY

1. Frame must be OEM for the year and brand
2. No modifications allowed to frame.
3. Hood must be OEM-for-the-model.
4. Windshield may be modified, replaced, or removed.
5. Headlight must be taped or removed and blocked with like material.
6. Fuel tank must be OEM-for-the-model and year or an exact aftermarket replacement.
7. Seat must maintain OEM contour and stock appearance for the model. Minimum seat thickness is 3 inches.

SUPER STOCK

In stock and stock-based classes, no change or modification is allowed unless specifically allowed by these rules. If these rules do not specifically allow a change or modification, then it must be assumed that the change or modification is not allowed.

1. Any stock qualified LEAF SPRING MODEL 1985 or older is eligible.
2. Entries will be segregated into classes based upon engine cooling (i.e., Fan, Free-air, Liquid).

SUPERSTOCK CLASSES

SUPER STOCK 250	264cc maximum
SUPER STOCK 300	317cc maximum
SUPER STOCK 340	358cc maximum
SUPER STOCK 440	464cc maximum
SUPER STOCK 800	836cc maximum

ENGINE

1. The engine must be OEM-for-the-model and year.
2. Engine, engine mounts and exhaust must remain in original OEM locations for the chassis used in competition.
3. Any internal modifications allowed to the engine. **Cylinder head hold down kits allowed. Heads may not be changed to accept hold down kit. (Hold downs not allowed in IFS Superstock)**
4. No external modifications allowed. Engine must maintain OEM-for-the-model appearance. (One timing hole is allowed)
5. Engine may only be bored to the class limit from which it is derived. No Stroke change is allowed. (No Sleeving Down)
6. An engine support may be added between engine and frame.
7. Existing Super Stock 300 class sleds that are built from 250 CC engines with designs that increase the displacement to a maximum of 317 CC will continue to be allowed. This is the only class that this practice is approved in. No other classes may be increased beyond the allowable overbore for the class derived from. **(Does not apply to IFS Superstock)**
8. Aftermarket pistons allowed.
9. Intake concept (for the engine) must be maintained (i.e., piston port, reed valve, etc.)
10. Round slide Mikuni carburetors from a stock qualified snowmobile only. No other carburetors allowed. No Flat slide/D.slide, or "peanut" carburetors allowed. Air intake silencers (air boxes) may be removed.
11. Cooling system concept (for the engine) must be maintained and fully functioning (i.e., free-air, fan, etc.).
12. Must be naturally aspirated.
13. OEM-for-the-model and year exhaust system must be used.
12. Any 1985 and prior OEM ignition allowed.

DRIVE

1. Any snowmobile brand OEM primary clutch allowed.
2. Any snowmobile brand OEM secondary clutch allowed. No roller secondary clutches allowed.
3. Chain case must be OEM. [\(Make Model\)](#)
4. Chain case may be moved up to 2 inches. **(Does not apply to IFS Superstock)**
5. Any track drive shaft and track drive sprockets allowed.
6. Track drive shaft may be relocated a maximum distance of 2 inches. **(Does not apply to IFS Superstock)**
7. For chassis without jackshaft, a jackshaft may not be added.

8. Jackshaft models may use any jackshaft. **(Superstock IFS No titanium jackshafts allowed)**
9. Brake components may be replaced. Must be commercially available and not modified.

SKI SUSPENSION AND STEERING

1. Skis must be aluminum or steel.
2. Leaf springs must be steel and functional. Leaf spring minimum length: 20 inches. **(Does not apply to IFS Superstock)**
3. Shock absorbers must be oil only, gas shock absorbers not allowed. **(Superstock IFS, any hydraulic or gas single body shock allowed, no remote reservoir shocks allowed.)**
4. Spindles and cross member ends must be enclosed.
5. Ski spreaders allowed. Maximum increase 3 inches (each ski). **(Does not apply to IFS Superstock)**
6. Any OEM or commercially available spindle is allowed. No modification to the spindle housing is allowed.
7. No Cobra skis allowed. **(Does not apply to IFS Superstock)**
8. Steering column must be OEM-for-the-model (chassis). The handlebars and/or handlebar mounting bracket may be modified or replaced.
9. Any commercially available handlebar allowed.

TRACK SUSPENSION

1. Remote adjusters are not allowed. **(Superstock IFS, any hydraulic or gas single body shock allowed, no remote reservoir shocks allowed.)**
2. Any OEM track suspension from a stock qualified, 1985 or older model is allowed. Original cleat track suspensions may be modified to fit required rubber tracks. Suspension limiting devices may be added. Wheels may be added, changed, or removed. **(Superstock IFS 1995 or older OEM suspensions allowed.)**

TRACK AND TRACTION

1. Any commercially available one-piece molded rubber track allowed. Track must fit within the confines of the tunnel without modification to track.
2. The track must be used as produced by the molder of the track. No cutting or other modifications allowed.

FRAME AND BODY

1. Frame must be OEM for the year and brand.
2. Frame reinforcement allowed. Frame must maintain stock dimensions.
3. Hood must be OEM-for-the-model. Windshield may be modified, replaced, or removed.
4. Headlight must be taped or removed and blocked with like material.
5. Any fuel tank may be used but must remain in stock location
6. Any seat may be used but must remain in the original location. Seat must retain 3 inches of thickness.
7. No adding of holes to belly pan or hood for cooling purposes. All holes to be blocked that are not from original factory design.

SUPERSTOCK IFS

SUPER STOCK IFS 500	470 cc Liquid Cooled, or 500 cc Fan Cooled.
SUPER STOCK IFS 580	If triple cylinder, must be piston port.
SUPER STOCK IFS 670	If triple cylinder must be piston port.

YEAR LIMITATIONS

1. Any OEM stock production IFS sled 1995 or older is legal for this class.

ENGINE

2. Maximum over bore .040 or 1 MM.

IFS SKI AND SUSPENSION

1. No remote reservoir shocks allowed. Suspension must retain original dimensions, mounting locations, and design.

REAR SUSPENSION

1. No remote reservoir shocks allowed. Rear suspension must retain original dimensions and design.

RELIC MOD

SUGGESTED CLASSES

RELIC Single	358 max. Fan/FA
RELIC 340	358cc maximum
RELIC 440	464cc maximum
RELIC 650	680cc maximum
RELIC 800	836cc maximum

ENGINE

1. The engine must be OEM-for-the-model. Engine must be from 1971 production or earlier. (Example 1970)
2. Engine, engine mounts and exhaust must remain in original OEM locations for the chassis used in competition.
3. Any internal modifications allowed to the engine.
4. External modifications allowed.
5. Intake and exhaust concept must be maintained.
6. Engine bore size may be increased up to class limit (see above).
7. Aftermarket pistons allowed.
8. Intake concept must be maintained (i.e., piston port, reed valve, etc.).
9. Any round slide carburetor from a stock qualified snowmobile is allowed. Flat slide carburetors allowed. Fuel injection not allowed.
10. Air intake silencers (air boxes) may be removed.
11. Any exhaust allowed. A commercially available silencer is required.
12. No liquid cooling allowed.
13. Must be naturally aspirated.
14. Torque stops may be added.

DRIVE

1. Any snowmobile brand OEM primary clutch allowed.
2. Any snowmobile brand OEM secondary clutch allowed. No roller secondary clutches allowed.
3. Any OEM chain case from a stock qualified snowmobile, 1985 or older model is allowed.
4. Chain case may be moved up to 2 inches.
5. Any track drive shaft and track drive sprockets allowed.
6. Track drive shaft may be relocated a maximum distance of 2 inches.
7. For chassis without jackshaft, a jackshaft may not be added. This rule will be strongly enforced to bring integrity to the class.
8. Jackshaft models may use any jackshaft.
9. Brake components may be replaced. Must be commercially available and not modified.

SKI SUSPENSION AND STEERING

1. Skis must be steel or aluminum.
2. Leaf springs must be steel and functional.
3. Ski spreaders allowed. Maximum increase 3 inches (each ski).
4. No Cobra skis allowed.
5. Any OEM steel steering column may be used. The handlebars and/or handlebar mounting bracket may be modified or replaced.
6. Any commercially available handlebar allowed.

TRACK SUSPENSION

1. Any OEM track suspension from a stock qualified, 1985 or older model is allowed.
2. Remote adjusters are not allowed.

TRACK AND TRACTION

1. Any commercially available one-piece molded rubber track allowed. Track must fit within the confines of the tunnel without modification to track.
2. The track must be used as produced by the molder of the track. No cutting or other modifications allowed.

FRAME AND BODY

1. Frame must be OEM-for-the-model.
2. Frame reinforcement allowed. Frame must maintain stock dimensions. Tunnel may be lengthened for fitment of rubber track and close off panel.
3. Hood must be OEM-for-the-model.
4. Windshield may be modified, replaced, or removed.
5. Headlight must be taped or removed.
6. Any snowmobile fuel tank may be used.
7. Seat must maintain OEM contour and stock appearance for the model. Minimum seat thickness is 3 inches.

SPORT MOD

1. Any 85 or older Stock Qualified or limited production race model with leaf springs is allowed.
2. Engine & mount must remain in original location.
3. No Pro Mod Drivers allowed (except single-cylinder class drivers).

SUGGESTED CLASSES

SPORT MOD 300	317cc maximum
SPORT MOD 340	358cc maximum
SPORT MOD 440	464cc maximum
SPORT MOD 800	836cc maximum

ENGINE

1. The engine must be OEM-for-the-model. Engine must be 1985 production or older.
2. Engine and engine mounting plate and mounts must remain in original OEM location for the model.
3. Any internal modifications allowed to the engine.
4. External modifications allowed.
5. Intake and exhaust concept must be maintained.
6. Engine bore size may be increased up to class limit (see above).
7. Aftermarket pistons allowed.
8. Intake concept must be maintained (i.e., piston port, reed valve, etc.).
9. Any round slide carburetor from a stock qualified snowmobile is allowed. Flat slide carburetors allowed. Fuel injection not allowed.
10. Air intake silencers (air boxes) may be removed.
11. Any exhaust allowed. A commercially available silencer is required.
12. No liquid cooling allowed.
13. Must be naturally aspirated.

DRIVE

1. Any snowmobile brand OEM primary clutch allowed.
2. Any snowmobile brand OEM secondary clutch allowed. No roller secondary clutches allowed.
3. Any OEM chain case from a stock qualified snowmobile 1985 or older is allowed.
4. Jackshaft installation allowed.
5. Track drive shaft may be relocated
6. Any track drive shaft and track drive sprockets allowed.
7. Brake components may be replaced. Must be commercially available and not modified.

SKI SUSPENSION AND STEERING

1. Skis must be steel or aluminum.
2. Leaf springs must be steel and functional.
3. Ski spreaders allowed. Maximum increase 3 inches (each ski).
4. No Cobra skis allowed.
5. Steering column must be OEM-for-the-model chassis. The handlebars and/or handlebar mounting bracket may be modified or replaced.
6. Any commercially available handlebar allowed.

TRACK SUSPENSION

1. Any track suspension allowed.

TRACK AND TRACTION

1. Any commercially available one-piece molded rubber track allowed. Track must fit within the confines of the tunnel without modification to track.
2. The track must be used as produced by the molder of the track. No cutting or other modifications allowed.

FRAME AND BODY

1. Frame must be OEM-for-the-model. Frame must originate from 1985 production or older. No reproduction frames allowed.
2. Frame reinforcement allowed. Frame must maintain stock dimensions.
3. Hood must be OEM-for-the-model.
4. Windshield may be modified, replaced, or removed.
5. Headlight may be removed.
6. Any OEM or aftermarket replacement snowmobile tank.
7. Any seat allowed.

SUPER MOD

The rules for this class are froze with the exception of safety requirements) for a period of three (3) years. The next time the rules will be open for change is the spring rules meeting of 2025 for the 2026 season.

1. Any 1985 or older leaf spring models allowed. 1972 and 73 Chaparrals also allowed.
2. Chaparrals must maintain OEM front- end dimensions and use designated oil only shocks (no gas shocks).
3. On Chaparral's, sway bar must be used in OEM location. A larger diameter sway bar may be used. To mount a larger diameter sway bar, the location may be moved up or down to clear drive.

SUGGESTED CLASSES

SUPER MOD 300	317cc maximum
SUPER MOD 340	358cc maximum
SUPER MOD 440	464cc maximum
SUPER MOD 650	680cc maximum
SUPER MOD 800	836cc maximum

ENGINE

1. The engine must be OEM for the brand and 1985 production or earlier.
2. Any 1985 cylinder for the brand may be used. Liquid cylinders not allowed. Cylinders must carry original identifying numbers to indicate cylinder type and production build. No cylinders of any type newer than 1985 may be used.
3. Crankcase and cylinders must be from the same stock qualified 1985 or older brand. Must retain the original number of cylinders.
4. Internal modifications allowed.
5. External modifications allowed.
6. Crankcase may be modified internally provided the engine remains its external stock appearance and dimension except as noted in these rules.
7. Reed block cages may be added to cylinders or crankcase.
8. Engine bore size may be increased up to class limit (see above).
9. Any round or flat slide, or D-slide snowmobile carburetor allowed. Fuel injection is not allowed.
10. Air intake silencers (air boxes) may be removed.
11. Any exhaust allowed. A commercially available silencer is required.
12. Must be naturally aspirated.

DRIVE

1. Any primary clutch allowed.
2. Any secondary clutch allowed. Roller secondary clutches allowed.
3. Any OEM snowmobile chain case or belt drive system allowed.
4. Jackshaft installation allowed.
5. Any track drive shaft and track drive sprockets allowed.
6. Track drive shaft may be relocated.
7. Brake components may be replaced. Must be commercially available and not modified.
8. If brakes are relocated to front drive shaft any external components must be properly shielded to avoid driver contact.

SKI SUSPENSION AND STEERING

1. Skis must be steel or aluminum.
2. Leaf springs must be steel and functional.
3. Ski spreaders allowed. Maximum increase 3 inches (each ski).
4. No Cobra skis allowed.
5. Any commercially available handlebar or steering column allowed.

TRACK SUSPENSION

1. Any track suspension allowed.
2. Remote adjustors are not allowed.

TRACK AND TRACTION

1. Any commercially available one-piece molded rubber track allowed. Track must fit within the confines of the tunnel without modification to track.
2. The track must be used as produced by the molder of the track. No cutting or other modifications allowed.

FRAME AND BODY

1. Bulkhead must be an original bulkhead, or a reproduction of an original bulkhead.
2. Frame must 1985 and older or a 1985 or older reproduction.
3. Frame reinforcement allowed.
4. Frame may be widened up to a 40" center-to-center carbide width. **(Hood and belly pan can be widened to cover increased width)**
5. **Hood must be OEM for the brand, or a same dimension replica. These panels must be OEM in appearance, less any scoops, vents, naca ducts, or air direction devices. The additional devices are not to exceed the total width of the snowmobile. Windshields cannot extend past the front bumper or extend rearward beyond the handlebars.**
6. Windshield may be modified, replaced, or removed.
7. Headlight may be removed.
8. Any fuel tank may be used.
9. Any seat allowed.

PRO MOD

1. Any 1974 or older Stock Qualified or OEM production racing snowmobile leaf spring models allowed. **(No clone or hand-built chassis allowed)**
2. 1972 and 73 Chaparrals also allowed.
3. Chaparrals must maintain OEM front-end dimensions and use designated oil only shocks (no gas shocks)
4. On Chaparral's, sway bar must be used in OEM location. A larger diameter sway bar may be used. To mount a larger diameter sway bar, the location may be moved up or down to clear drive.

SUGGESTED CLASSES

PRO MOD 300	317cc maximum
PRO MOD 340	358cc maximum
PRO MOD 440	464cc maximum
PRO MOD 650	680cc maximum
PRO MOD 800	836cc maximum

ENGINE

1. The engine must be OEM for the brand and 1985 production or earlier.
2. Any 1985 cylinder for the brand may be used. Liquid cylinders not allowed. Cylinders must carry original identifying numbers to indicate cylinder type and production build. No cylinders of any type newer than 1985 may be used. Any internal or external modifications allowed to the engine. No adding of reed valves, original intake concept must be maintained.
3. Engine bore size may be increased up to class limit (see above).
4. Internal modifications allowed.
5. External modifications allowed.
6. Any round slide or flat slide snowmobile carburetor allowed. Fuel injection is not allowed.
7. Air intake silencers (air boxes) may be removed.
8. Any exhaust allowed. A commercially available silencer is required.
9. Must be naturally aspirated.
10. Fan cooled engines cannot be revised to Free Air concept.

DRIVE

1. Any primary clutch allowed.
2. Any secondary clutch allowed. Roller secondary clutches allowed.
3. Any OEM snowmobile chain case or belt drive system allowed.
4. Jackshaft installation allowed.
5. Any track drive shaft and track drive sprockets allowed.
6. Track drive shaft may be relocated.
7. Brake components may be replaced. Must be commercially available and not modified.
8. If brakes are relocated to front drive shaft any external components must be properly shielded to avoid driver contact.

SKI SUSPENSION AND STEERING

1. Skis must be steel or aluminum.
2. Leaf springs must be steel and functional.
3. Ski spreaders allowed. Maximum increase 3 inches (each ski).
4. No Cobra skis allowed.
5. Any commercially available handlebar or steering column allowed.

TRACK SUSPENSION

1. Any track suspension allowed.
2. No remote adjusters allowed.

TRACK AND TRACTION

1. Any commercially available one-piece molded rubber track allowed. Track must fit within the confines of the tunnel without modification to track.
2. The track must be used as produced by the molder of the track. No cutting or other modifications allowed.

FRAME AND BODY

1. Frame must be OEM-for-the-model 1973 through 1985 production. **If later than 1973 must be OEM for the brand and retain dimensions of the 1973 frame.** Frame reinforcement allowed. Frame may be widened up to a 40" on center carbide width. **Hood must be OEM appearing for the model and brand.**
2. Windshield may be modified, replaced, or removed.
3. Headlight may be removed.
4. Any fuel tank allowed.
Any seat allowed

IFS SNO PRO

1. Only 82 or older IFS single-track limited production OEM racing snowmobiles allowed. No non-OEM, aftermarket or custom designs allowed.
2. No Champ or Sprint chassis allowed.
3. Reproduction chassis are allowed but must be built using exact measurements of bulkhead of the original production snowmobile. (i.e., A reproduction 78 IFS Ski-Doo must have tubular construction with the same measurements of the original 78 IFS Ski-Doo race snowmobiles.)

SUGGESTED CLASSES

SNO PRO 250	264cc maximum
SNO PRO 340	358cc maximum
SNO PRO 440	464cc maximum

ENGINE

1. The engine brand need not match the chassis brand.
2. Any 82 and older snowmobile engine is allowed.
3. No variable timing exhaust valves allowed.
4. Any internal modifications allowed to the engine.
5. External modifications allowed.
6. Intake and exhaust concept must be maintained.
7. Engine bore size may be increased up to class limit (see above).
8. Any round or flat slide snowmobile carburetor allowed. Fuel injection is not allowed.
9. Any exhaust allowed. A commercially available silencer is required.
10. Must be naturally aspirated.
11. The "250 Square Rotax" engine will be legal for Sno Pro 250 class.
12. 340 and 440 Rotax Rave cylinders, with the "Rave Valve" locked down will be legal for 340 and 440 Sno Pro classes.

DRIVE

1. Any primary clutch allowed.
2. Any secondary clutch allowed. Roller secondary clutches allowed.
3. Chain case must be in OEM location.
4. Jackshaft must remain in the OEM-for-the-model location.
5. Any track drive shaft and track drive sprockets allowed.
6. Brake components may be replaced. Must be commercially available and not modified.

SKI SUSPENSION AND STEERING

1. Skis must be steel or aluminum.
2. Any commercially available handlebar allowed.
3. Steering column must be in OEM for the model location.
4. Any shock absorbers allowed.
5. Sway bar may be replaced with a larger diameter sway bar.
6. Maximum overall width is 45 inches.

TRACK SUSPENSION

1. Any track suspension allowed.
2. Remote adjusters are not allowed.

TRACK AND TRACTION

1. Any commercially available one-piece molded rubber track allowed. Track must fit within the confines of the tunnel without modification to track.
2. The track must be used as produced by the molder of the track. No cutting or other modifications allowed.

FRAME AND BODY

1. Maximum snowmobile width 45 inches.
2. Hood must be OEM-for-the-model.
3. Shock and sway bar must stay in original locations.
4. Windshield may be modified, replaced, or removed.
5. Fuel tank must be OEM-for-the-model or an OEM or aftermarket replacement snowmobile tank.
6. Any seat allowed.
7. Reproduction tunnels and tunnel extensions allowed.

IFS SNO PRO X

In the X classes, IFS Sno Pro rules apply unless otherwise stated here.

SUGGESTED CLASSES

SNO PRO 250X	264cc maximum
SNO PRO 340X	358cc maximum
SNO PRO 440X	464cc maximum

ENGINE

1. The engine brand need not match the chassis brand.
2. External modifications limited to the addition of a reed valve system to a piston port engine only.
3. Any round or flat slide, or D-slide snowmobile carburetor allowed. Fuel injection is not allowed.
4. No variable timing exhaust valves allowed.
5. The "250 Square Rotax" engine will be legal for Sno Pro 250 class.
6. 340 and 440 Rotax Rave cylinders, with the "Rave Valve" locked down will be legal for 340 and 440 Sno Pro X class.

DRIVE

1. Jackshaft must remain in the OEM location for the model.
2. Any OEM for the brand chain case may be used.
3. Track drive axle must be within 2 inches of the OEM-for-the-model location.

BRAKES

1. If brakes are relocated to front drive shaft any external components must be properly shielded to avoid driver contact.

SKI SUSPENSION AND STEERING

1. Sway bar and shock absorber locations may be changed.
2. Sway bar may be replaced.

FRAME AND BODY

1. Any 82 or older Sno Pro hood allowed.

MOD STOCK

Suggested Classes:

M S 300	300 cc	317cc Max
M S 340	340 cc	358cc Max
M S 440	440 cc	464cc Max

Any 1985 or older, stock qualified or limited production racing snowmobile with leaf springs is eligible. Entries will be segregated into classes based upon engine cooling (i.e., Fan, Free-air, Liquid)

ENGINE

1. Engine must be OEM for the brand and 1985 production or earlier.
2. Engine and engine mounting plate and mounts must remain in original OEM location for the model.
3. Any internal modifications are allowed to the engine. (No Sleeving down).
4. Limited external modifications are allowed to the engine. Original engine concept must be maintained, for example Piston port, Reed valve, etc.
5. Engine bore size may be increased up to 0.060 inches over the class size.
6. Any carburetor is allowed. Flat slide carburetors are allowed.
7. Any exhaust system is allowed.

DRIVE

1. Any OEM primary clutch is allowed.
2. Any OEM secondary clutch is allowed. Roller secondary clutches are allowed.
3. Any OEM 85 and older chain case is allowed.
4. Any OEM 85 older track drive shaft is allowed. Any track drive sprocket may be used.
5. Track drive shaft may be relocated a maximum distance of two inches from OEM location.
6. Brake components may be replaced with commercially available unaltered components.

SKI SUSPENSION AND STEERING

1. Any aluminum extrusion replacement ski may be used which must maintain stock configuration. Leaf spring minimum length: 20 inches.
2. Exotic modifications are not allowed. If a shock absorber is used, it must be an emulsion type shock with only with direct linkage between spindle and ski as OEM design. No internal floating piston type or high-pressure gas shocks are allowed.
3. **Any OEM steel steering column may be used. The handlebars and/or handlebar mounting bracket may be modified or replaced.**

TRACK SUSPENSION

1. Any OEM track suspension from a stock qualified, 1985 or older model is allowed. Wahl or other aftermarket suspensions are not allowed. Original cleat track suspensions may be modified to fit required rubber tracks. Suspension limiting devices may be added. Wheels may be added, changed, or removed.

TRACK AND TRACTION

1. Any commercially available one-piece molded rubber track allowed. Track must fit within the confines of the tunnel without modification to track.
2. The track must be used as produced by the molder of the track. No cutting or other modifications allowed

FRAME AND BODY

1. Frame must match the brand.
2. Stock spindle width must be maintained. No offsets as measured from center of tunnel to center of spindles.
3. Hoods must be OEM for the model, or an exact replacement.
4. Any fuel tank is allowed.
5. Any seat is allowed.
6. Brake components may be replaced. Must be commercially available and not modified.

SPECIALTY CLASSES

Special sanctions and specialty classes must be approved in writing by ISR and the rules committee before competition.

1. Specialty classes can be any Vintage Oval Competition or class that does not fall under Vintage Oval class structure but meets established safety standards, applicable laws and complies with approved insurance coverage.

Specialty classes may be added from time to time.

MOD FAN SINGLE

1. Any stock qualified leaf spring, fan-cooled, single cylinder non-race model allowed.
2. The engine and chassis must be same brand.
3. Recommend 340 cc maximum.

ENGINE

1. Engine, exhaust, and mounts must remain in OEM location for the chassis.
2. Internal modifications allowed to the engine.
3. Engine bore size may be increased up to class limit.
4. Intake concept must be piston port.
5. Any carburetor from a stock qualified snowmobile is allowed. Flat slide carburetors and fuel injection not allowed.
6. Air intake silencers (air boxes) may be removed.
7. Engine must be functionally fan-cooled.
8. Must be naturally aspirated.

DRIVE

1. Any clutches allowed.
2. Drive shaft may be relocated.
3. Any track drive shaft and track drive sprockets allowed.
4. Brake components may be replaced. Must be commercially available and not modified.

SKI SUSPENSION AND STEERING

1. Skis must be steel or aluminum.
2. Steering column must be OEM-for-the-model chassis. The handlebars and/or handlebar mounting bracket may be replaced.
3. Any commercially available handlebar allowed.

TRACK SUSPENSION

1. Any track suspension

TRACK AND TRACTION

1. Any commercially available one-piece molded rubber track allowed. Track must fit within the confines of the tunnel without modification to track.
2. The track must be used as produced by the molder of the track. No cutting or other modifications allowed.

FRAME AND BODY

1. Frame must be OEM-for-the-model.
2. Frame reinforcement allowed.
3. May shorten or lengthen for track length.
4. Hood must be OEM for the make.
5. Windshield may be modified, replaced, or removed.
6. Headlight may be removed.
7. Fuel tank must be OEM-for-the-model or an OEM or aftermarket replacement snowmobile tank.

WCDC Specialty Class

SUPER STOCK IFS 540 LC

PVR Specialty Classes

PVR IFS 380 Stock Single Pipe

PVR 380 MOD FAN IFS CLASS RULES

Suggested Classes:

250IFSX/380X Sprint

Pro Mod 340 Single Fan

Super Seniors 250 Super Stock

Seniors 340 Super Stock

Mod Stock Classes 74 and older.

Women's Super-Stock 340 F/A-Fan

Masters 340 Pro Mod

0-440cc Pure Stock IFS Fan

0-504cc Pure Stock IFS Fan

Pro Mod 340 Single Fan Any stock qualified 1973 or older leaf spring, fan cooled, single cylinder 340cc maximum engine nonrace model snowmobile is eligible.

COMBINED DIVISION CLASSES

Pro Mod 340 Single Fan, Women's Pro Mod 340 Single, Single F/A Relic Mod 340. No separate scoring.

Women's Super-Stock 340 Free Air This class is for women drivers only. Super Stock rules apply. Maximum 340cc free air or 440 fan cooled engines is allowed.

Masters Drivers must be a minimum of 50 years old to compete in this class. Active Super Mod drivers are not eligible. Pro Mod (1985 and older) rules apply but may run up to a 1985 snowmobile. Maximum 340cc free air engine is allowed.

Masters IFS Sno Pro Drivers must be a minimum of 50 years old to compete in this class. IFSX Sno Pro Rules apply, 340cc maximum. Formula 500 rules apply for f500 sleds to compete.

Seniors Drivers must be a minimum of 60 years old to compete in this class. Active Pro Mod & Super Mod drivers are not eligible. Super Stock Free Air rules apply. Maximum 340cc engine is allowed.

Super Mod

Super Mod Liquid sleds are eligible for Super Mod 800 Free Air Class.

Super mod 250 liquid sleds can run in 300 Super mod free air

Super Mod Liquid 250 sleds can run in Super Mod Free Air 340 class.

Super Mod Liquid 340 sleds can run in Super Mod Free Air 440 class.

Super Mod Liquid 440 sleds can run in Super Mod Free Air 800 class.

(Please add to print so it is clearly understood)

(The liquid Super Mods are few, as they can only run one class. This gives more value to building a sled as you can run it in more places)

Stock Single Fan

Any stock qualified leaf spring 1973 or older fan cooled snowmobile is eligible. No limited production or race models are allowed.

ENGINE

1. Engine must be OEM for the model.
2. Engine, engine mounts, and exhaust must remain in original OEM location for the chassis
3. Any internal modifications are allowed to the engine.
4. Limited external modifications are allowed to the engine. Engine must maintain OEM appearance.
5. Engine bore size may be increased up to 0.060 inches over the class size. Aftermarket pistons are allowed.
6. Ignition must be OEM, or an OEM-type replacement.
7. Intake concept for the engine must be maintained.
8. Stock carburetor is required.
9. Engine must be fan cooled and fully functional.
10. Exhaust system must be OEM.
11. Original cooling concept for the engine and engine cylinders must be maintained and fully functioning.

DRIVE

1. Secondary clutch must be OEM.
2. Stock OEM primary clutch, or Comet Duster clutch, must be used. Springs, cams, and weights may be changed.
3. Chain case must be OEM. Chain case may be moved a maximum of one inch.
4. Any track drive shaft and track drive sprockets may be used.
5. Track drive shaft may be relocated a maximum distance of one inch from OEM location.
6. Brake components may be replaced with commercially available unaltered components.
7. If snowmobile is a jackshaft model, the jackshaft used must be OEM for the model. SKIS,

SUSPENSION, AND STEERING

1. Skis must be OEM for the model, or an aftermarket replacement which maintains OEM design.
2. Only oil filled shocks may be used on the skis (no gas shocks allowed).
3. Steering column must be OEM for the frame.
4. Any commercially available handlebar or handlebar mounting column may be used.
5. Ski spreaders allowed with a maximum of 3" per side. No offset steering allowed. TRACK

SUSPENSION

1. Any OE track suspension from a stock qualified, 1985 or older model is allowed.
- TRACK AND TRACTION 1. Rubber tracks are allowed if in good condition. NO CLEATED TRACKS allowed!

FRAME AND BODY

1. Frame must match the brand and must maintain stock dimensions and appearance for the model.
2. Modifications to the frame are not allowed. Frame reinforcement is not allowed.
3. Hoods must be OEM for the model, or an exact replacement.
4. Fuel tank should be OEM, or an aftermarket replacement tank which maintains OEM design.
5. Seat must maintain OEM contour and stock appearance for the model with a minimum thickness of three inches.

NO EXPRESS OR IMPLIED WARRANTY OF SAFETY SHALL RESULT FROM PUBLICATION OF OR COMPLIANCE WITH THESE RULES AND REGULATIONS. THEY ARE INTENDED AS A GUIDE FOR THE CONDUCT OF THE SPORT AND ARE IN NO WAY A GUARANTEE AGAINST INJURY OR DEATH TO SPECTATORS OR PARTICIPAN

THIS ENDS THE VINTAGE OVAL ON ICE

VINTAGE SNOW OVAL

GENERAL SNOWMOBILE REQUIREMENTS: VINTAGE SNOW OVAL COMPETITION

The intent of these classes is to establish races in which all can compete at their level of personal and equipment ability. The class structure is organized in such a way as to enable as many snowmobiles as a place to successfully compete. If class rules are not followed, the class name shall not be used and the class shall be run as a specialty class with ISR's prior approval. There will be differences from circuit to circuit in choice of displacement categories, eligible models, and year breaks. Classes and rules will be reviewed annually with the classes, possibility of revisions.

VINTAGE OVAL DIVISIONS STOCK SUPER STOCK MOD

GENERAL COMPETITION RULES from
Oval Sprint applies unless specified otherwise below.

GENERAL DRIVER REQUIREMENTS

It is the responsibility of the racer to select protective equipment that will conform to ISR guidelines and provide adequate protection. Even though race rules committees and ISR develop guidelines, ISR does not endorse or guarantee specific products or manufacturers of protective equipment. Racers must rely on their own judgment in the selection of helmets and other apparel for protection and durability.

1. Regardless of driver apparel passing prior inspections, compliance with the rules must be made at post-race inspections. Full coverage helmets are mandatory. Helmets will be full protective coverage and carry the 2010 Snell Foundation Approval Code. Helmets carrying European Standard ECE 22.05 are also approved. This is also mandatory in the tune-up area. The helmet must be securely fastened at all times.
2. (Oval, Cross Country, Enduro) It is mandatory that the driver's helmet must be a minimum of seventy five percent (75%) international or blaze orange.
3. For Enduro, Ice Lemans, Oval Sprint, Vintage oval, and Snow Cross: At least one hundred forty-four (144) square inches of visible area on both the driver's front and back (upper body) will be international or blaze orange in color at all events. Jackets / Pullovers / Jerseys will be tech'ed lying flat on the ground front and back. This is strongly recommended in all other types of racing.
3. Gloves and clothing, along with at least above ankle leather boots are mandatory (above ankle boot must have a minimum of 6 inches of leather above the ankle).
4. Eye protection mandatory; facemasks may be required at the starting line at the discretion of the Race Director. If corrective lenses are required to drive a motor vehicle, the driver will also be required to wear them when racing.
5. Hearing protection is mandatory in all non-stock classes in all types of competition. Recommended for all stock class competition.
6. The use of upper body protection equipment is mandatory, except for enclosed cockpits. The upper body protection must cover all body areas shown in illustration. It will protect the driver in mid-body and back areas and be capable of resisting penetration and dissipating force of impacts while absorbing the shock of most blows. Typical motocross vests do not meet this rule.
7. Shin and knee guards are mandatory. Shin and knee guards will be worn on both legs. The shin guard must extend from the instep to above the kneecap and be constructed of an impenetrable material.
8. Upper Arm Pads and Elbow pads are highly recommended in all forms of racing.
9. Neck bracing recommended in all forms of racing.

Upper Body Protection That Meets ISR Guidelines [Click Here](#)

Evs [Click Here](#)

Tek Vest [Click Here](#)

Saf-Jak [Click Here](#)

Leatt Adult [Click Here](#)

Leatt Youth [Click Here](#)

HMK Protective Vest [Click Here](#)

GENERAL SNOWMOBILE REQUIREMENTS

All snowmobiles in all classes must conform to all applicable rules in the ISR GENERAL RULES AND REGULATIONS section unless otherwise specified here.

DRIVE

1. Full coverage Clutch Cover (Mandatory in all classes except Stock and Super Stock where it is recommended.) The clutch cover must conform to the rule for Modified Oval Sprint classes.
2. Rear of tunnel must be enclosed as specified above in Super Stock and Mod classes. Optional in stock classes.

TRACK

1. See specific classes for proper conforming legal tracks.

SKI SUSPENSION AND STEERING

1. Leaf Spring Snowmobiles must have functional steel leaf springs.
2. Springs must be steel or OEM-for-the model if some other material.
3. **IN ALL CLASSES:** Offset ski stance not allowed unless OEM for the model.

FRAME AND BODY

1. Maximum overall width of any snowmobile is 45 inches (outside of skis or body, whichever is wider).

IGNITION AND ELECTRICAL

1. Programmable ignition systems allowed in mod classes. Ignition reprogramming is not allowed in the staging area or on the racetrack.
2. A working taillight is required in Super Stock and Mod classes, recommended in Stock classes.

RACE NUMBER IDENTIFICATION

1. Race number must be placed on both sides of hood in contrasting colors at least 4" high. Only one number may be displayed on the sled. If the sled is being raced by different drivers in different classes both must register using the same number.

STOCK

If these rules do not specifically allow a change or modification, then it must be assumed that the change or modification is not allowed.

1. Any stock qualified, production LEAF SPRING MODEL 1985 or older snowmobile that was available for purchase by consumers is eligible. Some models could be deemed non-qualified if they are found to be well above other qualifying sleds in each class in performance in which case they would be required to run in Super Stock or Mod classes.
2. Entries will be segregated into classes based upon engine cooling (i.e., Fan, Free-air, Liquid).

SUGGESTED CLASSES

STOCK Single Cylinder

STOCK 340

STOCK 500

ENGINE

1. The engine must be OEM-for-the model and year.
2. Engine, engine mounts and exhaust must remain in original OEM-for-the model locations (of the chassis).
3. No internal modifications allowed to the engine.
4. No external modifications allowed. Engine must maintain OEM-for-the model appearance.
5. Engine bore size may be increased to a maximum of 1mm over standard bore to compensate for cylinder wear or damage.
6. Aftermarket pistons allowed.
7. Intake concept (for the engine) must be maintained (i.e., piston port, reed valve, etc.)
8. Stock class sleds may use up to a 40 mm round slide carburetor.
Air intake silencers (air boxes) may be removed or modified.
9. Cooling system concept (for the engine) must be maintained and fully functioning (i.e., free-air, fan, etc.).
10. Must be naturally aspirated.
11. OEM-for-the-model exhaust system must be used and may not be modified. No wrapping or special coating of pipe allowed.
12. The only legal ignitions will be OEM 1985 and older. All ignitions must be derived from a stock qualified model 1985 and older, or a designated aftermarket replacement of the original component.

13. Programmable ignitions are not allowed.

DRIVE

1. Any snowmobile brand OEM or aftermarket primary clutch that was available in 1985 or previous allowed. A newer clutch may be used if the exact model was available in 1985 or before. Example: New Comet 94c or 102c clutches are still produced but were available in 1985 and are legal.
2. Secondary clutch must be OEM-for-the-model chassis.
3. Chain case must be OEM for model and year.
4. Any track drive shaft and track drive sprockets may be used.
5. For chassis without jackshaft, a jackshaft may not be added.
6. Jackshaft models must use OEM for the model jackshaft.
7. Brake components may be replaced but must be commercially available and not custom built.

SKI SUSPENSION AND STEERING

1. Steel skis from any qualified 1985 and older production snowmobile of any brand may be used. No aluminum, plastic, or aftermarket skis allowed. No pointed skis may be used, all ski loops and tips must be well padded.
2. Only round steel wear bars may be used (no carbides) with a maximum width of 1/2"
3. Leaf springs must be steel and functional.
4. Only oil filled shocks can be used on the skis. Shocks must mount in original position. (No Gas Shocks)
5. Steering column must be OEM-for-the model chassis. The handlebars and/or handlebar mounting bracket may be replaced.
7. Handlebars may be modified or replaced with any commercially available handlebar. Hooks may be added.

TRACK SUSPENSION

1. Any track suspension from a stock qualified, 1985 or older model is allowed. Suspension must be used with no modification allowed. Marginal snow wheels can be added or deleted.
2. Remote Adjusters are not allowed

TRACK AND TRACTION

1. Any brand one-piece molded rubber track allowed must have been a Model produced in 1985 and prior. Track must fit within the confines of the tunnel without modification to track 3. The track must be used as produced by the molder of the track. No cutting or other modifications allowed. No "porting" of track allowed.
4. No studs or traction devices of any type allowed.

FRAME AND BODY

1. Frame must be OEM for the year and brand
2. No modifications allowed to frame.
3. Hood must be OEM-for-the-model
4. Windshield may be modified, replaced, or removed.
5. Headlight must be taped or removed.
6. Any production fuel tank from any brand or model snowmobile may be used but must remain in original location for model. No aftermarket or custom fuel tanks allowed.
7. Seat must maintain an approximate stock appearance for the model. Seat must not be more than 4" higher than original seat. Minimum seat thickness is 3 inches

NOTICE

In stock and stock-based classes, no change or modification is allowed unless specifically allowed by these rules. If these rules do not specifically allow a change or modification, then it must be assumed that the change or modification is not allowed.

SUPER STOCK

1. Any stock qualified LEAF SPRING MODEL 1985 or older machine is eligible.
2. Entries will be segregated into classes based upon engine cooling (i.e., Fan, Free-air, Liquid).

SUPER STOCK SUGGESTED CLASSES

SUPER STOCK 340
SUPER STOCK 500

ENGINE

1. The engine must be OEM-for-the model and year.
2. Engine, engine mounts and exhaust must remain in original OEM locations for the chassis used in competition.
3. Any internal modifications allowed to the engine. Cylinder head hold down kits allowed. Heads may not be changed to accept hold down kit.
4. No external modifications allowed. Engine must maintain OEM-for-the model appearance. Engine components from other model snowmobiles may not be substituted unless they have identical part numbers.
5. Engine bore size may be increased by a maximum of 1mm over class limit for wear and damage.
6. Aftermarket pistons allowed.
7. Intake concept (for the engine) must be maintained (i.e., piston port, reed valve, etc.)
8. Any round slide carburetor up to 44 MM may be used. Air intake silencers (air boxes) may be removed or modified.
9. Cooling system concept (for the engine) must be maintained and fully functioning (i.e., free-air, fan, etc.).
10. Must be naturally aspirated.
11. OEM-for-the-model and year exhaust system must be used. Exhaust may be coated but coating must not cover exhaust to point where stock verification is not possible. Head pipes and exhaust chamber may be wrapped with heat barrier tape.
13. Wye Pipe, head pipe, diverging cone, center section, receding (converging) cone, external expansion chamber cover, internal stingers, stinger length, and exhaust outlet location may not be changed or altered.
12. Any 1985 and prior OEM ignition allowed.

DRIVE

1. Any snowmobile brand OEM or aftermarket primary clutch allowed.
2. Any snowmobile brand OEM secondary clutch allowed. No roller secondary clutches allowed.
3. Chain case must be OEM may be used. Belt drive system not allowed.
4. Chain case may be moved up to 2 inches.
5. Any track drive shaft and track drive sprockets allowed.
6. Track drive shaft may be relocated a maximum distance of 2 inches.
7. For chassis without jackshaft, a jackshaft may not be added.
8. Jackshaft models may use any jackshaft.
9. Brake components may be replaced. Must be commercially available and not modified.

SKI SUSPENSION AND STEERING

1. Any production or aftermarket steel or aluminum skis may be used.
2. Leaf springs must be steel and functional. Leaf spring minimum length: 20 inches.
3. Shock absorbers must be oil only, gas shock absorbers not allowed.
4. Spindles and cross member ends must be enclosed.
5. Ski spreaders allowed. Maximum increase 3 inches (each ski).
6. Any OEM or commercially available spindle is allowed. No modification to the spindle housing is allowed.
7. No Cobra skis allowed.
8. Steering column must be OEM-for-the model (chassis). The handlebars and/or handlebar mounting bracket may be modified or replaced.
9. Any commercially available handlebar allowed.

TRACK SUSPENSION

1. Remote adjusters are not allowed.
 2. Any OEM track suspension from a stock qualified, 1985 or older model is allowed. Original cleated track suspensions may be modified to fit required rubber tracks. Suspension limiting devices may be added.
- Wheels may be added, changed, or removed.

TRACK AND TRACTION

1. Any commercially available one-piece molded rubber track allowed with a maximum lug depth or 1" Track must fit within the confines of the tunnel without modification to track.

2. The track must be used as produced by the molder of the track. No cutting or other modifications allowed. "Porting" of track not allowed.
3. Any stud may be used with a minimum tip angle of 60 degrees and a maximum height of 3/8" above the highest lug of the track.

FRAME AND BODY

1. Frame must be OEM for the year and brand.
2. Frame reinforcement allowed. Frame must maintain stock dimensions.
3. Hood must be OEM-for-the-model. Windshield may be modified, replaced, or removed.
4. Headlight must be taped or removed and blocked with like material.
5. Any fuel tank may be used but must remain in stock location
6. Any seat may be used but must remain in the original location. Seat must retain 3 inches of thickness.

MOD

1. Any 1985 or older Stock Qualified leaf spring model allowed. Sled must maintain general "Vintage" appearance.

SUGGESTED CLASSES

MOD 340 F/A
MOD 500 F/A
MOD 340 L/C
MOD 500 L/C

ENGINE

1. The engine and snowmobile must be of the same brand and of 1985 production or earlier.
2. Any internal or external modifications allowed to the engine.
3. Engine bore size may be increased up to class limit + up to 1mm over standard bore for wear and repair.
4. No stroker cranks or stroke change allowed.
5. Any snowmobile carburetor allowed. Fuel injection is not allowed.
6. Air intake silencers (air boxes) may be removed or modified.
7. Any exhaust allowed. A commercially available silencer is required.
8. Must be naturally aspirated.

DRIVE

1. Any primary clutch allowed.
2. Any secondary clutch allowed. Roller secondary clutches allowed.
3. Any snowmobile chain case may be used. Chain case must retain a cover to protect driver from chain and sprockets. No open chain cases, or belt drive cases allowed.
4. Jackshaft installation allowed.
5. Any track drive shaft and track drive sprockets allowed.
6. Track drive shaft may be relocated
7. Brake components may be replaced. Must be commercially available and not modified.
8. If brakes are relocated to front drive shaft any external components must be properly shielded to avoid driver contact.

SKI SUSPENSION AND STEERING

1. Any steel or aluminum skis may be used.
2. Leaf springs must be steel and functional.
3. Ski spreaders allowed. Maximum increase 3 inches (each ski).
4. No Cobra skis allowed.
5. Any commercially available handlebar or steering column allowed.

TRACK SUSPENSION

1. Any track suspension allowed.
2. Remote adjusters are not allowed.

TRACK AND TRACTION

1. Any commercially available one-piece molded rubber track allowed. Track must fit within the confines of the tunnel without modification to track.
2. The track must be used as produced by the molder of the track. No cutting or other modifications allowed. No "porting" of the track will be allowed.

3. Any stud may be used with a minimum tip angle of 60 degrees and a maximum height of 3/8" above the highest lug of the track.

FRAME AND BODY

1. Reproduction chassis are allowed but must be built using exact measurements of bulkhead of the original production snowmobile.
2. Frame must be 1985 and older or a 1985 or older reproduction.
3. Frame reinforcement allowed.
4. Frame may be widened up to a 40" center-to-center carbide width.
5. Hood must be OEM for the brand and of 1985 style or older.
6. Windshield may be modified, replaced, or removed.
7. Headlight must be removed or taped.
8. Any fuel tank is allowed
9. Any seat allowed.

NO EXPRESS OR IMPLIED WARRANTY OF SAFETY SHALL RESULT FROM PUBLICATION OF OR COMPLIANCE WITH THESE RULES AND REGULATIONS. THEY ARE INTENDED AS A GUIDE FOR THE CONDUCT OF THE SPORT AND ARE IN NO WAY A GUARANTEE AGAINST INJURY OR DEATH TO SPECTATORS OR PARTICIPANTS.

ISR Rules Updated 2022-23 Race Season