

iColor Accent MX Powercore

Precision-controlled direct view linear exterior LED luminaire with intelligent color light



iColor Accent MX Powercore

Precision-controlled direct view linear exterior LED luminaire with intelligent color light

iColor Accent MX Powercore is a direct view linear LED luminaire ideally suited for creating long ribbons of color and color-changing effects. Variable resolution offers the precision to display large-scale video, graphics, and intricately designed effects in a host of architectural, retail, and entertainment settings. iColor Accent MX Powercore offers the efficiency and cost-effectiveness of Powercore technology in an outdoor-rated, road-ready aluminium housing.

- Integrates patented Powercore technology — Powercore technology rapidly, efficiently, and accurately controls power output to iColor Accent MX Powercore luminaires directly from line voltage. Philips Data Enabler Pro merges line voltage and control data and delivers them to the luminaire over a single cable, dramatically simplifying installation and lowering total system cost.
- Native, onboard Ethernet — Luminaires accept Ethernet input from Data Enabler Pro to support long control runs not subject to DMX data and addressing limitations.
- Precise resolution control — Luminaires can be addressed and controlled in increments down to 30 mm (1.2 inches), or up to 1.2 m (4 ft).
- Two luminaire lengths — 0.6 m (2 ft) and 1.2 m (4 ft) lengths are easily connected to create long, continuous columns of intense, dynamic color.
- Rugged, durable construction — This IP66-rated luminaire is designed to meet the taxing requirements of outdoor and entertainment applications. The extruded aluminium housing resists shock, vibration, and other forms of rough handling.
- Flexible positioning — Over-molded end-to-end locking connectors supply both power and data. Connectors can make 180° turns for easy layout. Jumper cables of 305 mm (1 ft), 610 mm (2 ft), 1.5 m (5 ft), and 3 m (10 ft) can add extra space between luminaires.
- Industry-leading controls — Works seamlessly with the complete Philips line of controllers, including Video System Manager Pro, Light System Manager, and iPlayer 3, and any third-party controllers.
- Universal power input range — Accepts a universal power input range of 100 to 240 VAC for consistent installation anywhere in the world. Each Data Enabler Pro can support multiple luminaires for creating long lines of video or ribbons of intricately changing color.



Exceptional Viewing Angles

The diffused plastic lens, specifically designed for direct viewing, provides exceptional viewing angles of 250° x 180°, and ensures uniform color mixing.

Linear Lighting — Redefined

iColor Accent MX Powercore luminaires are designed to create columns of dynamic color for a wide range of architectural accenting, retail, and entertainment applications, including large-scale video displays. iColor Accent MX Powercore combines the benefits of precise resolution control, patented Powercore technology, and onboard Ethernet control to redefine the capabilities of linear lighting. Using Philips Video System Manager Pro controller, iColor Accent MX Powercore can create seamless lines of video on building exteriors and other indoor and outdoor surfaces. Through appropriate sampling and optimization, displays can be visible from many hundreds of feet or meters away.

Towering Video

To get attention in Atlantic City and differentiate its exterior from that of its neighbors, Harrah's Resort and Casino created the world's largest outdoor video display by covering the façade of the 44-story Waterfront Tower in a linear array of over 4,500 iColor Accent Powercore luminaires.

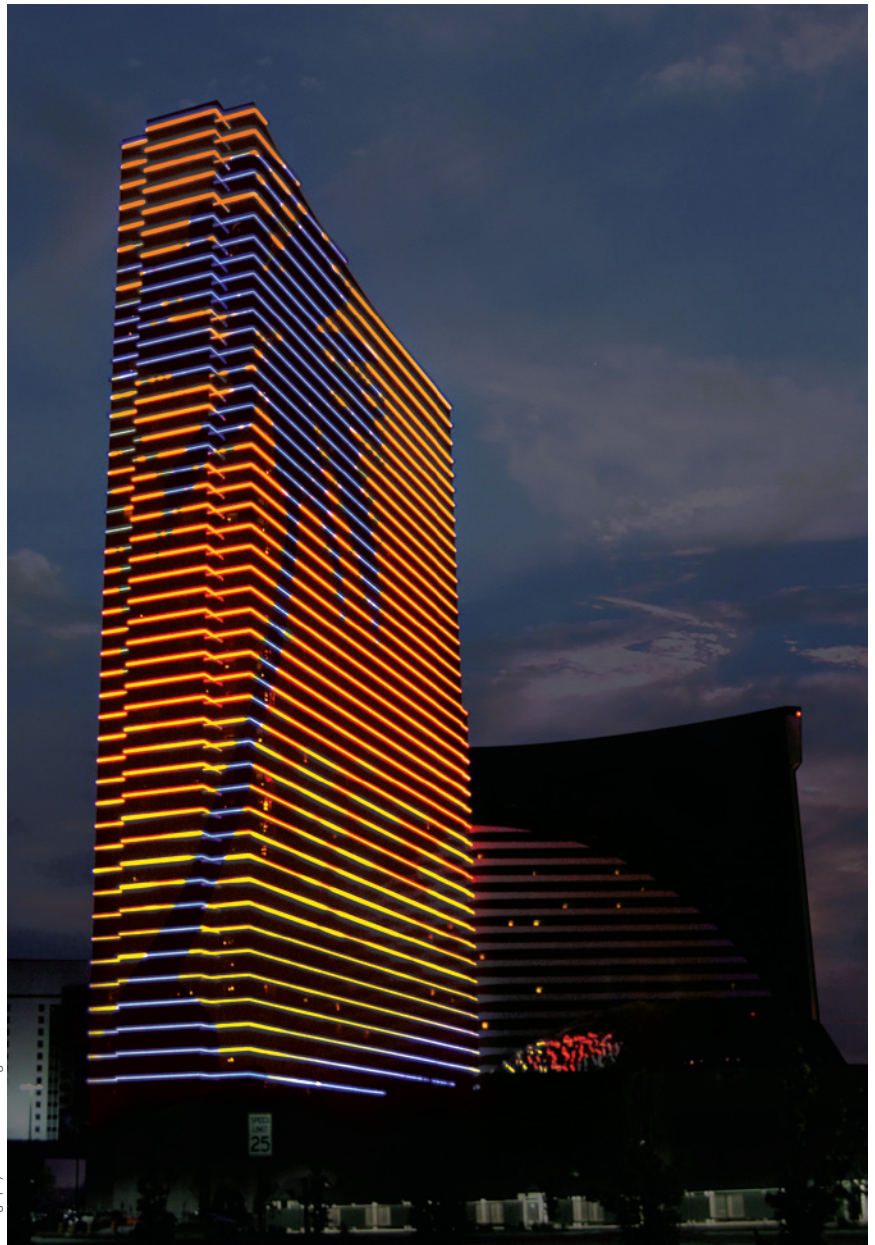

Photography: Tim Hunter-Design

Approximately 33,000 linear feet – almost six linear miles – of LED-based “tubes” wrap around the four façades of the Waterfront Tower. From dusk to dawn, the entire building turns into a large video screen displaying scenes that range from the celestial (stars, comets, shooting stars) to the patriotic (a waving American flag and fireworks) to the casino-inspired (rolling dice, scrolling card suits).

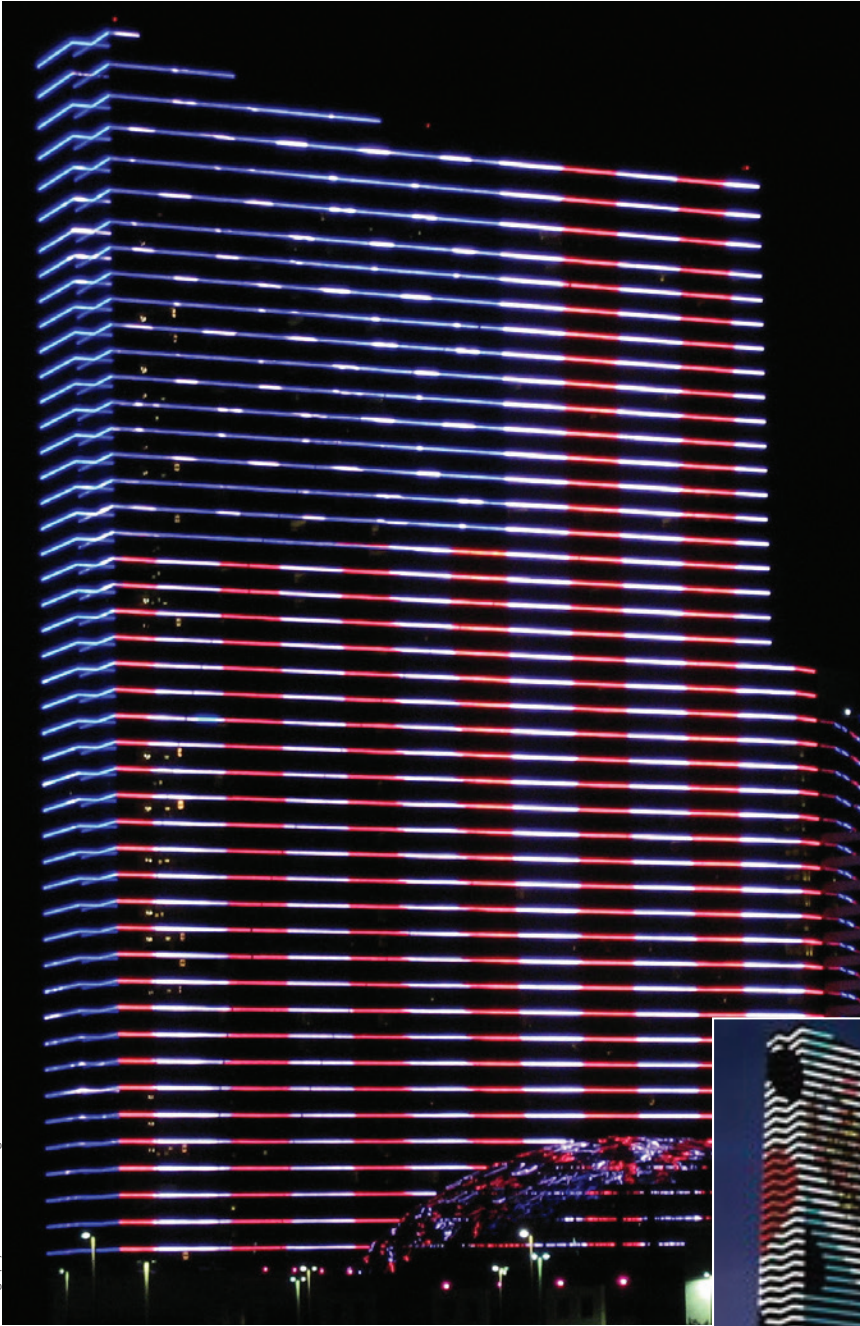

Photography: Tim Hunter Design

With control resolution down to 1.2-inch increments, iColor Accent Powercore allows designers to put video and dynamic effects where they have never gone before — without the large price tag and cumbersome installation requirements of most high-resolution displays.



Photography: Tim Hunter Design

Tommy Hilfiger Denim

The Tommy Hilfiger Denim store in New York City prominently features an innovative and eye-catching installation comprised entirely of iColor Accent Powercore luminaires. The chandelier-like structure, titled “Monument to an

Amaranth” in homage to the colorful flower that never fades, is designed to be the decorative focal point of the store. 135 iColor Accent Powercore luminaires create seamless columns of intricately changing color in a captivating centerpiece 1.8 m (6 ft) high and 1.2 m (4 ft) wide. Luminaires are installed on a custom-designed steel chaise suspended from the ceiling on aircraft cables.

By setting the luminaires to maximum resolution, the video designer was able to use individually controllable light segments of just 30 mm (1.2 in) to display low-resolution video, graphics, and intricately designed effects

The video designer used 3D animation software to create a 12-minute, looping video reproduced by the lighting installation. The installation uses Philips Video System Manager Pro, an integrated software / hardware control solution, to convert the video signals and stream the content to the iColor Accent Powercore luminaires.

The inaugural video included images of celebration and nature, beginning with fireworks

that morph sequentially into fire, falling water, and growing vines that bloom into a sea of flowers. At the beginning of every season, the designer creates new video content to keep the installation fresh.



Photography: Reed Barrow

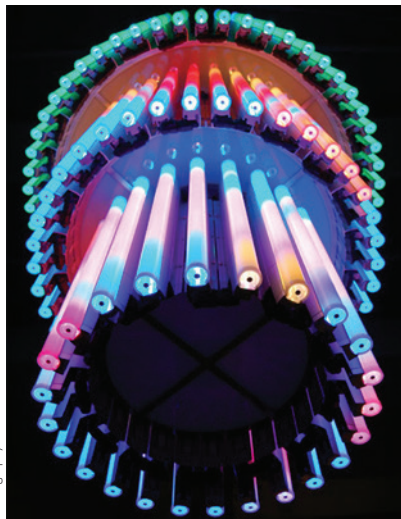

Photography: Reed Barrow



Specifications

Due to continuous improvements and innovations, specifications may change without notice.

Item	Specification	0.6 m (2 ft)	1.2 m (4 ft)
Output	Viewing Angle	220°	
	On-Axis Candela	52 (4 ft luminaire)	
	Lumens*	327 (4 ft luminaire)	
	Lumen Maintenance†	50,000+ hours L50 @ 50° C (full output)	
	LED Channels	Red/Green/Blue	
Electrical	Input Voltage	100 to 240 VAC, auto-switching, 50/60 Hz via Data Enabler Pro	
	Power Consumption	10 W per foot maximum at full output, steady state	
Control	Interface	Data Enabler Pro (DMX/Ethernet)	
	Control System	Philips full range of controllers, including Video System Manager Pro, Light System Manager, and iPlayer 3, or third-party controllers	
Physical	Dimensions (Height x Width x Depth)	100 x 608 x 63 mm (3.9 x 23.9 x 2.5 in)	100 x 1214 x 63 mm (3.9 x 47.8 x 2.5 in)
	Weight	2 kg (4.5 lb)	4.2 kg (9.3 lb)
	Housing	Sealed plastic and extruded aluminium	
	Lens	Translucent plastic	
	Luminaire Connections	Over-molded, integral male / female connectors	
	Temperature Ranges	-40 to 122 °F (-40 to 50 °C) Operating -4 to 122 °F (-20 to 50 °C) Startup -40 to 176 °F (-40 to 80 °C) Storage	
	Maximum Luminaires Per Data Enabler Pro	25	25
	Humidity	0 to 95%, non-condensing	
Certification and Safety	Certification	UL/cUL, CE	
	Environment	Dry/Damp/Wet Location, IP66	

* Lumen measurement complies with IES LM-79-08 testing procedures.

† L50 = 50% lumen maintenance (when light output drops below 50% of initial output).

Ambient luminaire temperatures specified. Lumen maintenance calculations are based on lifetime prediction graphs supplied by LED source manufacturers. Calculations for white-light LED luminaires are based on measurements that comply with IES LM-80-08 testing procedures. Refer to www.philipscolorkinetics.com/support/appnotes/lm-80-08.pdf for more information.

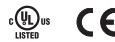

CHROMASIC CK TECHNOLOGY | POWERCORE CK TECHNOLOGY | CHROMACORE CK TECHNOLOGY

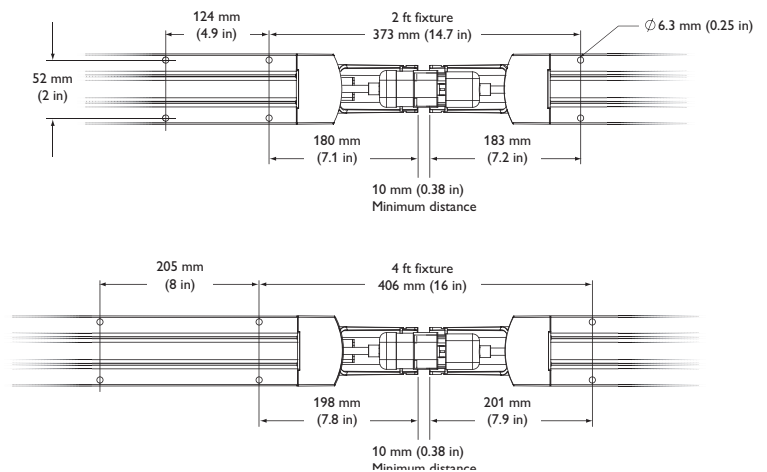
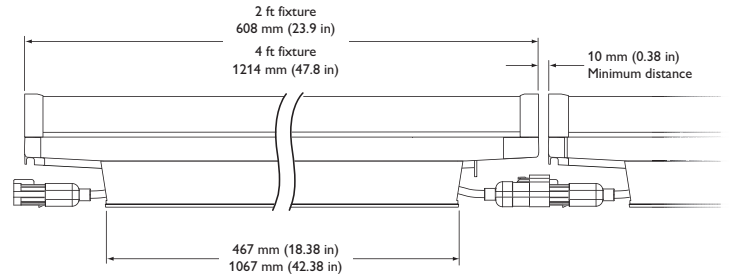
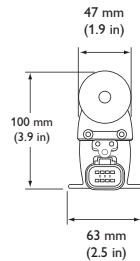

Luminaires and Accessories

iColor Accent MX Powercore is part of a complete system which includes luminaires and:

- One or more Data Enabler Pro devices
- One Leader Cable to connect each Data Enabler Pro output to a series of luminaires
- Optional Jumper Cables to add space between luminaires in a series, if necessary
- Any Philips controller, including Video System Manager, Light System Manager 3, iPlayer 3, or any third-party controller

Included in the box

iColor Accent MX Powercore luminaire
Strain relief fitting
Washer
Ear clamp
Luminaire terminator
Installation Instructions

Item	Type	Item Number	Philips 12NC
iColor Accent MX Powercore	0.6 m (2 ft)	123-000018-00	910503701068
	1.2 m (4 ft)	123-000018-01	910503701069

Leader Cable <i>with terminator and strain relief</i>	15.2 m (50 ft)	108-000028-00	910503700086
	305 mm (1 ft)	108-000029-03	910503700087
Jumper Cable	610 mm (2 ft)	108-000029-06	910503700090
	1.5 m (5 ft)	108-000029-05	910503700089
	3 m (10 ft)	108-000029-04	910503700088

Data Enabler Pro	3/4 in / 1/2 in NPT (U.S. trade size conduit)	106-000004-00	910503701210
	PG21 / PG13 (metric size conduit)	106-000004-01	910503701211

Use Item Number when ordering in North America.

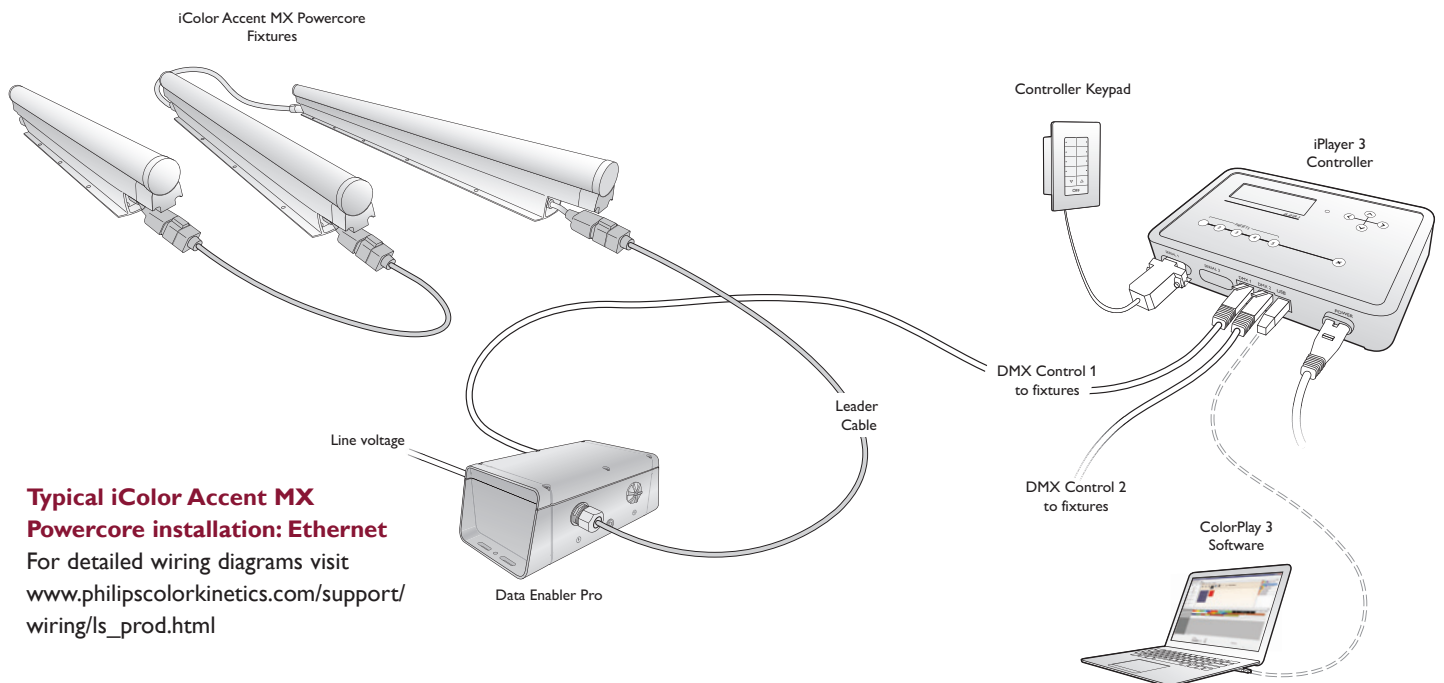

Typical iColor Accent MX Powercore installation: Ethernet

For detailed wiring diagrams visit www.philipscolorkinetics.com/support/wiring/lc_prod.html

Installation

iColor Accent MX Powercore luminaires are ideally suited for creating long ribbons of color and color-changing effects. Variable node size offers the precision to display large-scale video, graphics, and intricately designed effects in a host of architectural, retail, and entertainment settings, including permanent building-covering displays.

Owner / User Responsibilities

It is the responsibility of the contractor, installer, purchaser, owner, and user to install, maintain, and operate iColor Accent MX Powercore luminaires in such a manner as to comply with all applicable codes, state and local laws, ordinances, and regulations. Consult with the appropriate electrical inspector to ensure compliance.

 Refer to the iColor Accent MX Powercore Installation Instructions for specific warning and caution statements.

Installing in Damp or Wet Locations

When installing in damp or wet locations, seal all luminaire connections, power / data supplies, and junction boxes with electronics-grade RTV silicone sealant so that water or moisture cannot enter or accumulate in wiring compartments, cables, or other electrical parts. Use suitable outdoor-rated junction boxes when installing in damp or wet locations. Additionally, use gaskets, clamps, and other parts required for installation to comply with all applicable local and national codes.

Planning Your Installation

Because of their potential complexity, iColor Accent MX Powercore installations require upfront planning for configuring, positioning, and mounting luminaires. iColor Accent MX Powercore luminaires receive power and data from the Philips Data Enabler Pro. Planning includes understanding how to set luminaires' node size (pixel resolution), how to position luminaires in relation to Data Enabler Pro devices, the number of luminaires you can connect together in a single run, and whether you need to connect luminaires end-to-end or use jumper cables to add extra space between them. Planning for video displays involves additional considerations such as pixel pitch, minimum and maximum viewing distances, sampling, and display resolution.

All installations involve three main steps:

1. Create a lighting design plan and layout grid
2. Address and configure luminaires
3. Mount and test luminaires

If you're creating a simple installation with relatively few lights, or if you're running an Ethernet lighting network with an accessible Ethernet switch, you can install the lights first, then address and configure them after installation. For more complex installations, especially for installations that require luminaires to be hung in locations that are difficult to access or installations in which luminaires are not all visible from a single location, you may want to address luminaires in a staging area before installing them.

Understanding Node Size and Pixel Resolution

To allow a fine level of control, iColor Accent MX Powercore luminaires offer variable node size. A node is an individually controllable luminaire segment of a certain length. iColor Accent MX Powercore nodes can be as large as the full length of the luminaire or as small as 30 mm (1.2 in). A 1.2 m (4 ft) luminaire, for instance, can act as one large node, or it can have as many as 40 nodes of 30 mm (1.2 in) each.

In architectural accenting and entertainment applications, you typically use larger node sizes for filling spaces or washing surfaces with a desired intensity of color-changing light. In video applications, the appropriate node size is determined by the maximum and minimum viewing distances and video resolution.

Number of Nodes Per Luminaire

Luminaire Length	Nodes Per Luminaire
0.6 m (2 ft)	1 to 20
1.2 m (4 ft)	1 to 40

DMX or Ethernet Control?

iColor Accent MX Powercore luminaires can accept either DMX or Ethernet (KiNET) data input. Because of addressing limitations, DMX is appropriate for relatively simple installations, or for light shows in which multiple luminaires or luminaire nodes operate in unison. Since a DMX universe consists of 512 addresses, the maximum number of individually addressable iColor Accent MX Powercore nodes in a DMX universe is 170 ($170 \times 3 = 510$). This limitation can determine the maximum number of luminaires per Data Enabler Pro in installations with dynamic color-changing light shows. For example, four 4 ft luminaires at the maximum number of nodes per luminaire will exceed the entire range of unique DMX addresses in a universe, even though the Data Enabler Pro is capable of supporting up to 25 1.2 m (4 ft) luminaires in a single run.

Because it is not subject to DMX addressing limitations, Ethernet is the preferred environment for intricate color-changing light shows and video displays calling for hundreds or thousands of nodes that must be controlled individually. In an Ethernet lighting network, each iColor Accent MX Powercore luminaire effectively functions as its own universe, identified by the luminaire's unique IP address.

A typical DMX installation uses a DMX controller such as iPlayer 3 or a third-party DMX controller. A typical Ethernet installation uses one or more Ethernet switches, and an Ethernet controller such as Light System Manager or Video System Manager Pro. You can connect a series of up to 25 iColor Accent MX Powercore luminaires to a single Data Enabler Pro.

Achieving Consistent Node Size

Consistent node size can be important for planning both video installations and dynamic light shows. Node sizes that divide evenly into a luminaire's total length remain consistent across multiple luminaires installed end-to-end, regardless of luminaire length.

Consistent Node Sizes

Node Size	Nodes Per 0.6 m (2 ft) Luminaire	Nodes Per 1.2 m (4 ft) Luminaire
30 mm (1.2 in)	20	40
61 mm (2.4 in)	10	20
122 mm (4.8 in)	5	10
152 mm (6 in)	4	8
305 mm (12 in)	2	4
610 mm (24 in)	1	2

You can select node sizes other than those listed above, but they each create one shorter node at the end of each luminaire. For example, assigning a node size of 213 mm (8.4 in) to a 610 mm (2 ft) luminaire creates two nodes of 213 mm (8.4 in) and one node of 183 mm (7.2 in), because $213 + 213 + 183 = 610$ mm ($8.4 + 8.4 + 7.2 = 24$ in, rounding up).

Additional Considerations for Video Displays

Along with the planning required for any iColor Accent MX Powercore installation, planning for video displays involves additional considerations such as pixel pitch, minimum and maximum viewing distances, sampling, and display resolution.

Determining Pixel Pitch and Viewing Distances for Video Displays

In a video display, each luminaire node functions as a pixel in the display. Planning for low-resolution video displays involves designing a layout for your iColor Accent MX Powercore luminaires that determines the pixel sizes and places the pixels close enough together to accommodate video at acceptable minimum and maximum viewing distances.

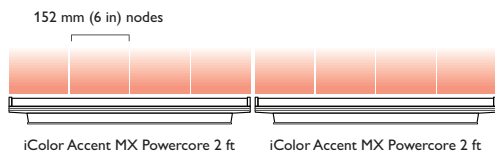

Node sizes that divide evenly into the total luminaire length ensure consistency of presentation across luminaires. A consistent node size can be important for the proper display of video and other dynamic light show content.

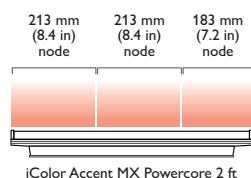

Node sizes that do not divide evenly into the total luminaire length leave an inconsistently sized node at the end of each luminaire.

Images on an LED video display appear to be sharper to the human eye as the distance to the display increases. Likewise, images appear less visible as the distance decreases. The spacing between pixels, known as the *pixel pitch*, determines the minimum and maximum viewing distances for discernible video output.

Pixel pitch is measured center-to-center. In an iColor Accent MX Powercore luminaire, where there may be no black space between pixels, you determine pixel pitch by measuring from the center of one node to the center of the next.

There are number of ways of adjusting pixel pitch using iColor Accent MX Powercore luminaires:

- You can separate pixels within a single luminaire by configuring the video display so that every other luminaire node is black.
- You can separate pixels horizontally between luminaires by using jumper cables.
- You can separate pixels vertically between luminaires by spacing your luminaire runs.

The following calculations and examples are general guidelines for determining minimum and maximum viewing distances, based on video displays using grids of evenly spaced pixels:

- To determine the minimum viewing distance, multiply the pixel pitch by 100 distance units. For example, if the pixel pitch is 50 mm, the minimum viewing distance is 5 m (16.4 ft).
- To determine the maximum viewing distance for discernible video, multiply the screen height by 20 distance units. For example, if the screen height is 20 m (65.6 ft), then the maximum viewing distance for recognizable video is 400 m (1312.3 ft).
- LED screens are visible beyond the maximum viewing distance for discernible video. To determine the maximum viewing distance that still creates visual impact, multiply the screen height by 50 units. For example, a screen 20 m (65.6 ft) high will continue to create visual impact at 1000 m (3280.8 ft).

Working with Video Display Resolutions

The resolution of an LED video display equals the total number of vertical and horizontal pixels — the greater the pixel count, the greater the resolution.

- The resolution of VSE digital video is 1024 x 768
- The resolution of PAL video is 704 x 576
- The resolution of NTSC video is 704 x 480

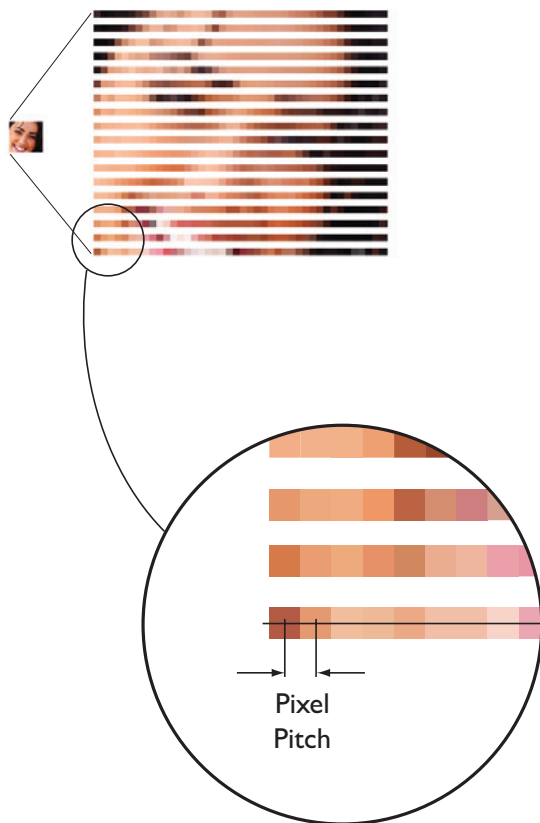
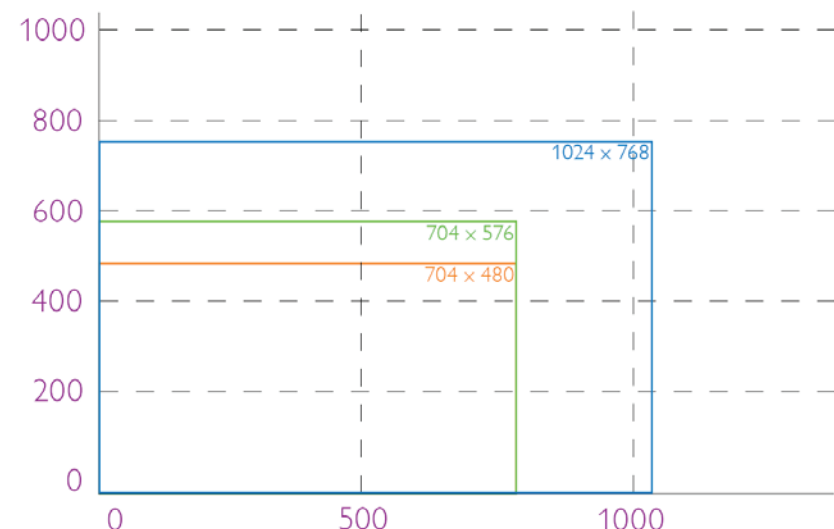

* VSE Pro, or Video System Engine Pro, is the hardware component of Video System Manager Pro, an integrated video controller from Philips Color Kinetics. Visit www.philipscolorkinetics.com/ls/controllers/vsmpro/ for complete information

✳ For designs where the acceptable level of discernible video may be more or less demanding, or for help with your specific installation, contact Philips Color Kinetics Applications Engineering Services for assistance.

Reproducing a video signal with 1:1 pixel mapping on an LED display requires a substantial pixel count. For example, true NTSC video output requires 337,920 pixels, PAL output requires 405,504 pixels, and digital video output requires 786,432 pixels.

However, you can use a controller such as Philips Video System Manager Pro to reduce the required pixel count for any video format by sampling and distributing pixels from the source video to match your installation.

For example, if you retain the horizontal resolution of a digital video source (1024 lines wide), but sample every tenth line of pixels vertically (76 lines high instead of 768 lines), you can retain the correct aspect ratio while exponentially reducing the pixel count. From a distance, even with only 76 lines of vertical output, the human eye can still discern video images because the horizontal resolution is dense.

An installation using 1024 x 76 nodes would have a pixel count of 77,824 yet still display high-quality digital video output. This method is especially effective when creating an installation that covers a building which, by necessity, already has spacing between lines of video due to windows and other architectural features.

You can reduce pixel count either horizontally or vertically by using jumper cables to add space between iColor Accent MX Powercore luminaires. As in the above example, you would sample and distribute pixels from the source video to match the pixel size and spacing of your installation.

Create a Lighting Design Plan and Layout Grid

Even for relatively simple installations, it's good practice to create a lighting design plan that identifies your luminaires, records their IP addresses and node sizes, and identifies their locations and the locations of other required hardware. For complex installations displaying light shows with dynamic effects, and especially for Ethernet-based video displays, a detailed lighting design plan is essential.

A lighting design plan is typically an architectural diagram or other diagram that shows the physical layout of the installation, including the appropriate positioning and spacing of all required luminaires, power sources, controllers, and cables. Some professional video content companies specialize in creating video designs and supporting lighting design plans.

Keep the following considerations in mind when creating a lighting design plan and layout grid:

1. Determine the appropriate location of each Data Enabler Pro in relation to the luminaires, and of the luminaires in relation to each other.

You connect the first luminaire in a series to a Data Enabler Pro with a 15.2 m (50 ft) Leader Cable. Refer to the Data Enabler Pro Installation Instructions or Product Guide for guidelines on configuring and positioning the Data Enabler Pro in relation to the controller or Ethernet switch.

2. iColor Accent MX Powercore luminaires are installed in series. The in-line connectors allow end-to-end luminaire connections for the best visual effects. When connected end-to-end, luminaires can be installed as close as 10 mm (0.38 in) apart. When you need to separate luminaires by more than this amount, use the 305 mm (1 ft), 610 mm (2 ft), 1.5 m (5 ft), or 3 m (10 ft) jumper cables.

Minimum distance between luminaires

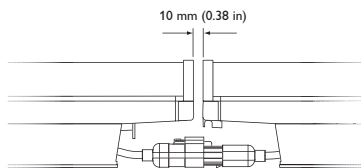

✳ Using jumper cables may decrease the number of luminaires you can connect in a run. For help calculating the number of luminaires your specific installation can support, download the Configuration Calculator from www.philipscolorkinetics.com/support/install_tool, or consult Philips Applications Engineering Services at support@colorkinetics.com.

- Each run of luminaires can include a maximum of 25 luminaires. Total run length, including luminaires, Leader Cable, and Jumper Cables, must not exceed 91.4 m (300 ft).

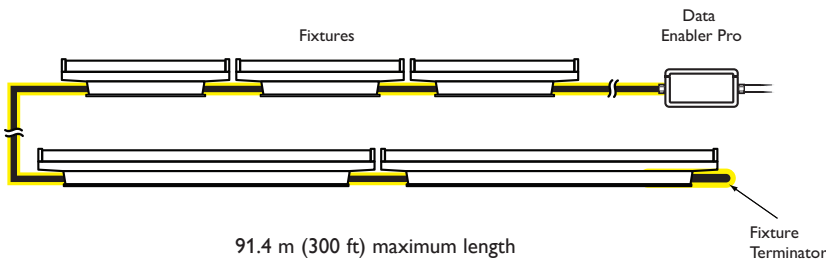

- Connectors are gender-specific. Since the Leader Cable has a female connector, all lights in a run must be installed with their male connectors facing toward the Data Enabler Pro.
- On an architectural diagram or other diagram that shows the physical layout of the installation, identify the locations of all switches, controllers, power supplies, luminaires, and leader and jumper cables.

Start the Installation

- Install all Data Enabler Pro devices, including any interfaces with controllers. One Leader Cable is required to connect each run or series of luminaires to a Data Enabler Pro. Data Enabler Pro sends power and control signals to the luminaires over the Leader Cable.
- Verify that all additional supporting equipment (switches, controllers) is in place.
- If your installation calls for Jumper Cables to add space between luminaires, make sure they are available.
- Ensure that all additional parts (#10 mounting screws suitable for the mounting surface, clamps, truss, terminators) and tools (screwdrivers, pincers or pliers) are available.

* For complete instructions on how to wire the Data Enabler Pro, refer to the Data Enabler Pro Installation Guide or Product Guide. For sample wiring diagrams, visit www.philipscolorkinetics.com/support/wiring/l_s_prod.html.

Unpack and Prepare Luminaires

- Carefully inspect the box containing iColor Accent MX Powercore and the contents for any damage that may have occurred in transit.
- Each iColor Accent MX Powercore luminaire has an onboard Ethernet switch and comes pre-programmed with a unique IP address. As you unpack the luminaires, record the IP addresses in a layout grid (typically a spreadsheet or list) for easy reference and light addressing.

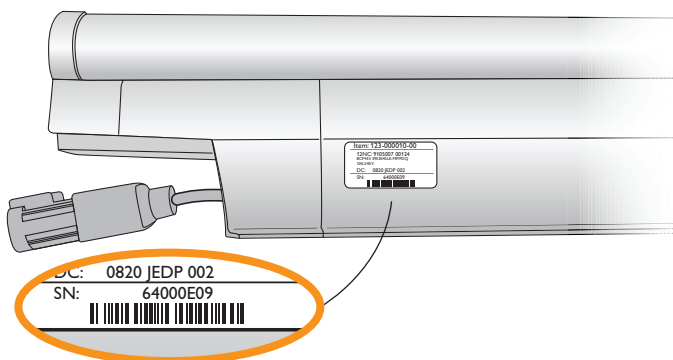

Included in the box

iColor Accent MX Powercore luminaire
Strain relief fitting
Washer
Ear clamp
Installation Instructions

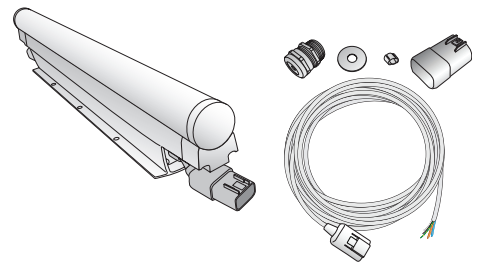

3. Assign each luminaire to a position in the lighting design plan.
4. To streamline installation and aid in light show programming, you can affix a weatherproof label identifying the order or placement in the installation to an inconspicuous location on each light luminaire's housing.

Mount and Connect Luminaires

Make sure the power is OFF before mounting and connecting iColor Accent MX Powercore luminaires.

1. Position the first luminaire in a series and attach it with #10 mounting screws suitable for the mounting surface. Ensure that the male connector is in a position to receive data and power from the Leader Cable.

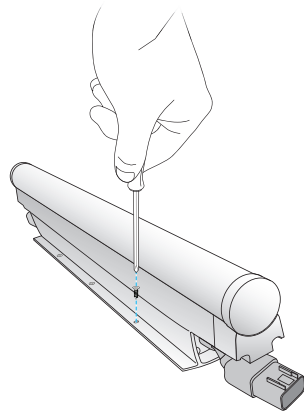

2. Position the next luminaire in the series, matching the male connector end to the female connector of the previously mounted luminaire. The flexible connector cables allow for up to 180° turns.

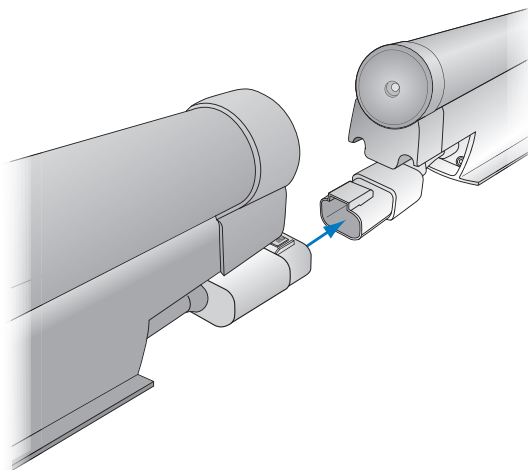

3. Continue mounting the luminaires, making power / data connections as you go, until all lights in the series are mounted.

4. Insert the provided luminaire terminator into the last luminaire in the series.

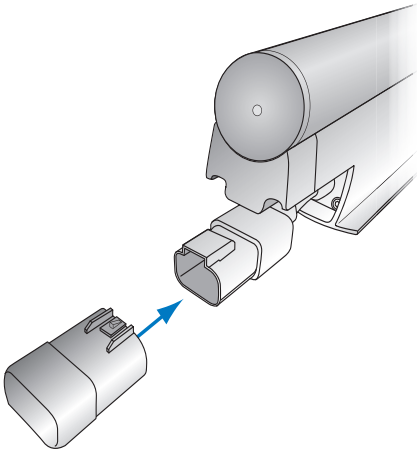

5. Connect the Leader Cable to the first luminaire in the series.

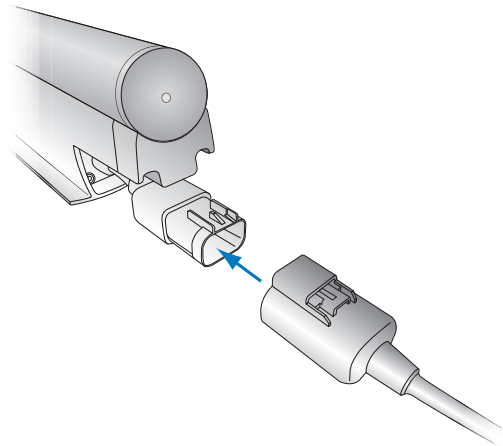

6. Make Data Enabler Pro connections:

- Remove the Data Enabler Pro cover.
- Attach a strain relief fitting to the Data Enabler Pro. Apply RTV silicone between fitting and enclosure, and insert the Leader Cable through strain relief fitting, washer, and ear clamp. Route the Leader Cable to its final destination in the Data Enabler Pro enclosure.

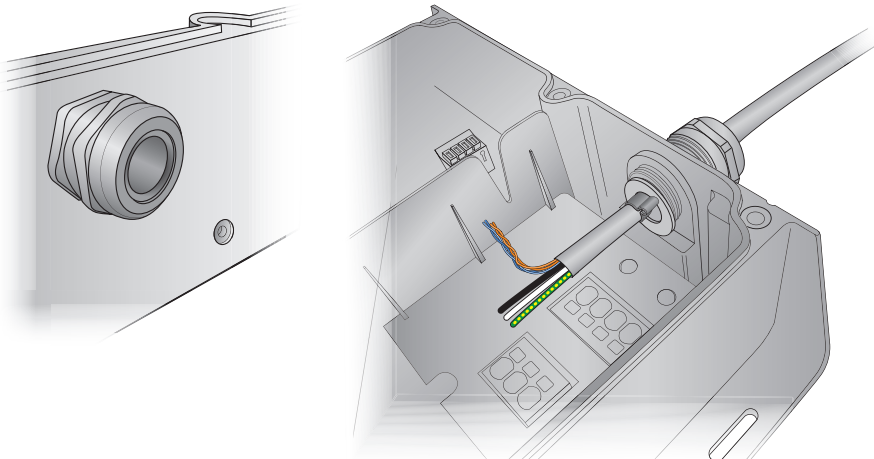

- Position the ear clamp near the opening. Crimp both ears of the ear clamp uniformly around the Leader Cable with pliers or pliers. Tighten the strain relief nut, compressing the fitting snugly around the Leader Cable.

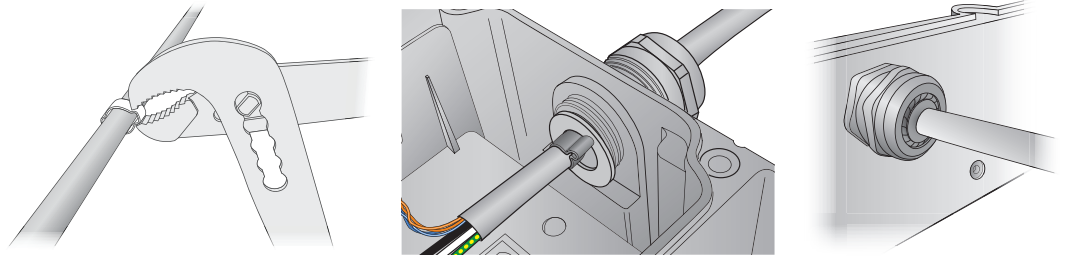

* Refer to the Data Enabler Pro Product Guide for comprehensive installation and configuration instructions. You can view or download the guide from www.philipscolorkinetics.com/lspds/dataenablerpro

- Inside the Data Enabler Pro housing, connect the Leader Cable's data wires to the 4-wire IDC terminal block, and the line, neutral, and ground wires to the luminaire cable 4-wire terminal block.

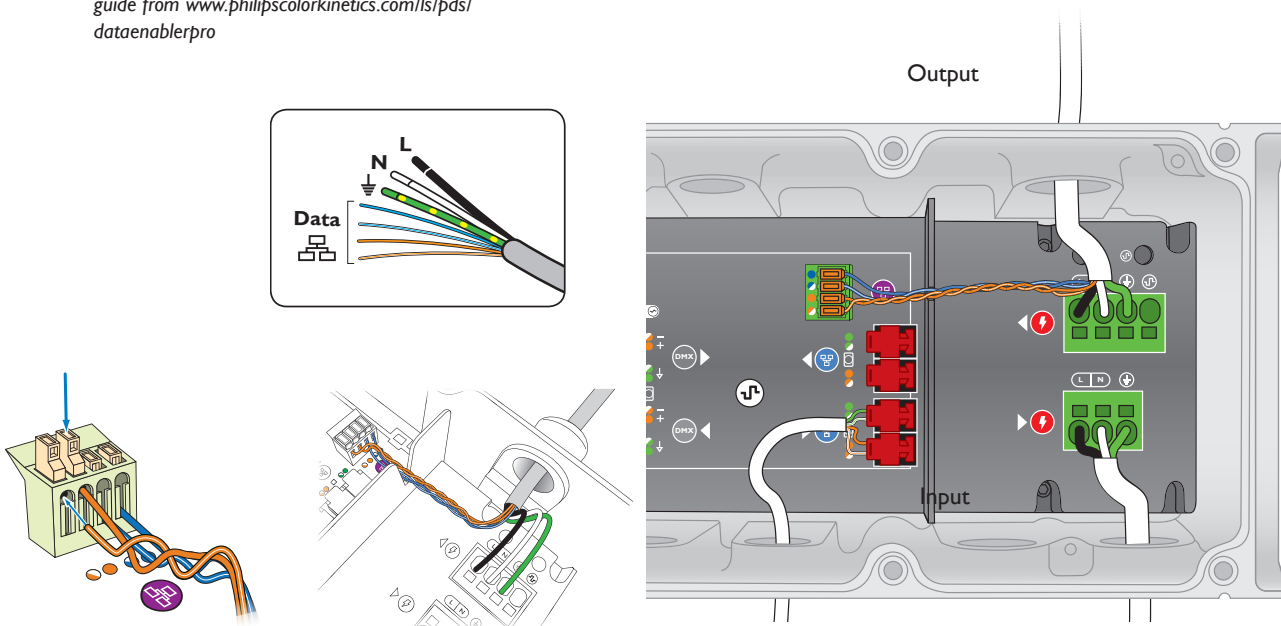

Address and Configure the Luminaires

Make sure the power is ON before addressing and configuring luminaires.

iColor Accent MX Powercore luminaires have variable node sizes, ranging from 1.2 in (30 mm) to the entire length of the luminaire. Each node uses three consecutive DMX addresses, one for the red LED channel, one for the green channel, and one for the blue channel. A single iColor Accent MX Powercore luminaire, therefore, uses from 3 to 120 DMX addresses, depending on configuration.

iColor Accent MX Powercore nodes are addressed using *light numbers*. A light number corresponds to three sequential DMX addresses. Light number 1 corresponds to DMX addresses 1, 2, and 3; light number 2 corresponds to DMX addresses 4, 5, and 6; light number 3 corresponds to DMX addresses 7, 8, and 9; and so on. Since a DMX universe consists of 512 DMX addresses, there are 170 light numbers per universe ($170 \times 3 = 510$, with two DMX addresses left over).

iColor Accent MX Powercore luminaire nodes are automatically assigned light numbers consecutively, beginning with the luminaire's starting light number. For instance, if you set a 0.6 m (2 ft) luminaire to have 20 30.4 mm (1.2 in) nodes and

light number 22, the luminaire is automatically assigned 60 DMX addresses, 64 to 123 (light numbers 22 to 41). If you set a 4 ft luminaire to have one 4 ft node and starting light number 134, the luminaire is automatically assigned three DMX addresses, 400 to 402.

iColor Accent MX Powercore luminaires are factory-configured with a starting light number of 1 and the largest node size — that is, each luminaire is configured to use DMX addresses 1, 2, and 3 and to display one solid color at a time. For light show designs that display the same color simultaneously on all luminaire nodes, no addressing is necessary. For designs that show different colors on different nodes simultaneously, you must assign a unique set of DMX addresses to each luminaire node.

Because it eliminates the addressing limitations of DMX, Ethernet is preferred for lighting installations that display intricate effects requiring hundreds or thousands of individually addressable nodes. In Ethernet networks, each luminaire is identified by a unique IP address and effectively functions as its own DMX universe. As long as all iColor Accent MX Powercore IP addresses are unique within an installation, the set of DMX addresses assigned to a given luminaire is unique within the installation.

- In DMX installations, you can set luminaire node size (pixel resolution) and starting light number using QuickPlay Pro with a computer connected directly to a Data Enabler Pro device using a standard Ethernet cable or Ethernet crossover cable.
- In Ethernet installations, you can address and configure luminaires using QuickPlay Pro with a computer connected to an Ethernet switch in your lighting network. QuickPlay Pro automatically discovers all iColor Accent MX Powercore luminaires for quick configuration. Alternatively, you can discover and address luminaires using an Ethernet controller such as Light System Manager or Video System Manager Pro.

For complete details on addressing and configuring iColor Accent MX Powercore luminaires, refer to the *Addressing and Configuration Guide*.

 You can download QuickPlay Pro from www.philipscolorkinetics.com/support/addressing/

Attach Safety Cable (Optional)

When dictated by local or state code or advised by a structural engineer, attach a safety cable to the iColor Accent MX Powercore luminaire housing and tether it to a secure anchor point.

1. Thread a safety cable through the luminaire housing as shown.
2. Attach the safety cable to the mounting surface using a method that follows the code or engineer's requirements.

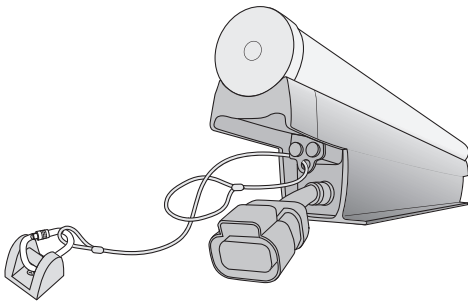

Safety cable minimum requirements

Material	304 or 316 Stainless Steel
Size	3.2 mm (1/8 in) nominal diameter. Minimum break load must be greater than 953 kg (2,100 lb).



Philips Color Kinetics
3 Burlington Woods Drive
Burlington, Massachusetts 01803 USA
Tel 888.385.5742
Tel 617.423.9999
Fax 617.423.9998
www.philipscolorkinetics.com

Copyright © 2017 Philips Lighting Holding B.V. All rights reserved.
Chromacore, Chromasic, CK, the CK logo, Color Kinetics, the Color Kinetics logo, ColorBlast, ColorBlaze, ColorBurst, ColorGraze, ColorPlay, ColorReach, iW Reach, eW Reach, eW Fuse, DIMand, EssentialWhite, eW, iColor, iColor Cove, IntelliWhite, iW, iPlayer, Optibin, and Powercore are either registered trademarks or trademarks of Philips Lighting Holding B.V. in the United States and / or other countries. All other brand or product names are trademarks or registered trademarks of their respective owners. Due to continuous improvements and innovations, specifications may change without notice.
Cover Photo: Tim Hunter Design

DAS-000073-00 R02 09-17